

ANVIL-STRUT™

A BRAND OF ANVIL INTERNATIONAL

ANVIL-STRUT™ METAL FRAMING CONDENSED ENGINEERING CATALOG AND PRICE SHEET

AS - 3.05 • EFFECTIVE March 7, 2005
Cancels Price List PS - 10.04

CHANNEL

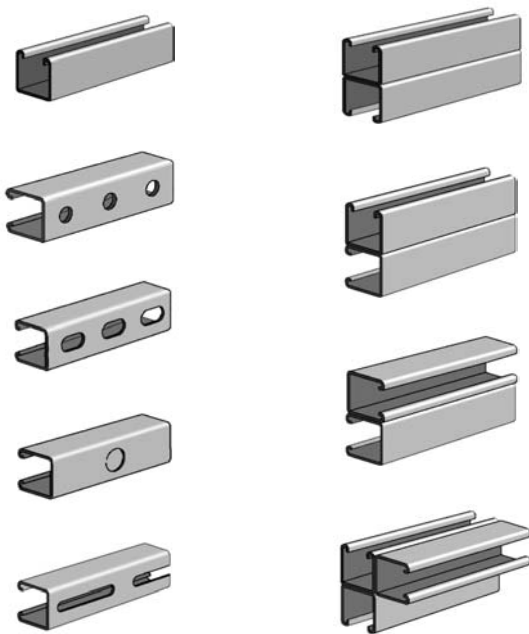

SPRING NUTS



PIPE AND CONDUIT SUPPORTS

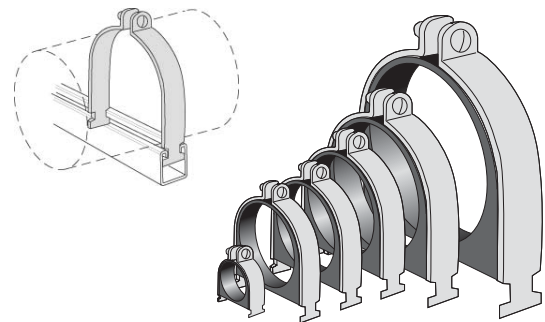

FITTINGS & ACCESSORIES



SUBJECT TO CHANGE WITHOUT NOTICE.
GO TO WEB SITE FOR MOST CURRENT
LIST PRICE INFORMATION/CHANGES
OR CONTACT AN ANVIL REPRESENTATIVE.

www.anvilintl.com

Today Anvil International is the largest and most complete fitting and hanger manufacturer in the world.

2004 Anvil International acquires Star Pipe Products, Building and Construction Divisions (SPF) and forms Anvil Star Fire Products Division.

2001 Anvil International acquires Merit Manufacturing and Beck Manufacturing.

2000 The industry's trusted manufacturer of pipe fittings, hangers and grooved fittings is renamed Anvil International, Inc.

1999 Tyco sells the distribution and manufacturing operations known up to this point as Grinnell Supply Sales, but keeps the "Grinnell" name.

1994 J.B. Smith and Catawissa join the Grinnell Supply Sales and Manufacturing division.

1969 Grinnell Co. acquired by International Telephone and Telegraph. Two years later, ITT divests the Fire Protection Division, but keeps the manufacturing and sales divisions that will become known as Anvil International.

1960 Gruvlok line of grooved fittings is introduced.

1919 General Fire Extinguisher Co. becomes Grinnell Co.

1909 Frederick Grinnell opens a foundry in Cranston, RI. Companies express interest in buying its piping products, laying the groundwork for what would become the Grinnell Supply Sales Division. It would be these manufacturing and sales operations that eventually become Anvil International.

1850 Providence Steam & Gas Pipe Co. is formed, and Frederick Grinnell purchases a controlling interest.

TRUSTED FOR 150 YEARS

We built our reputation from the ground up.

Anvil's history stretches back to the mid 1800s, when a company named Grinnell began providing its customers with the finest quality pipe products. Since 2000, those quality products and services—and the people who provide them—have been known as Anvil International. Anvil customers receive the quality and integrity that have been building strong connections in both products and business relationships for over 150 years.

Focused Product Line:

Anvil® Malleable and Cast Iron Fittings

Anvil® Hangers, Supports and Struts

Beck Welded Pipe Nipples

Anvil® Seamless Pipe Nipples

Anvil® Steel Pipe Couplings and Small Steel Fittings

Merit® O'Lets and Drop Nipples

Gruvlok® Couplings, Fittings and Valves

SPF™ Imported Cast Iron and Ductile Iron Fittings

SPF™ Grooved Fittings and O'Lets

J.B. Smith Swage Nipples and Bull Plugs

Catawissa® Wing Unions and Check Valves



BUILDING CONNECTIONS THAT LAST



ANVIL®
INTERNATIONAL, INC.

ANVIL BRANDS:

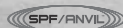

TABLE OF CONTENTS

Section	Description	Page
1	Channel	2 – 22
2	Channel Nuts and Hardware	23 – 27
3	Fittings and Accessories	28 – 56
4	Pipe and Conduit Supports	57 – 63
5	Klo-Shure®	64 – 65
6	Concrete Inserts	66 – 68
7	Technical Information	69 – 80
—	Product Index	81 – 83
—	Terms and Conditions	84

<u>PRODUCT CODES</u>	
Code	Product Category
A	Channels
B	Pipe Clamps
C	Channel Nuts
D	General Fittings Hardware
E	Concrete Inserts
F	Cushion Clamps/Klo-Shure®

WARNING
 Anvil-Strut™ products are carefully designed and manufactured to the listed standards, as applicable. However, Anvil-Strut™ reserves the right to revise product design without notification. Anvil-Strut™ products included in this catalog are intended for installation and service only as described or specified herein. Care should be exercised by installers and end-users to install, use and maintain these products properly to avoid any possible on-the-job accidents. Prices subject to change without notice.

SECTION 1 – CHANNEL

ANVIL-STRUT™ CHANNEL FABRICATION DATA

ANVIL-STRUT™ STYLES

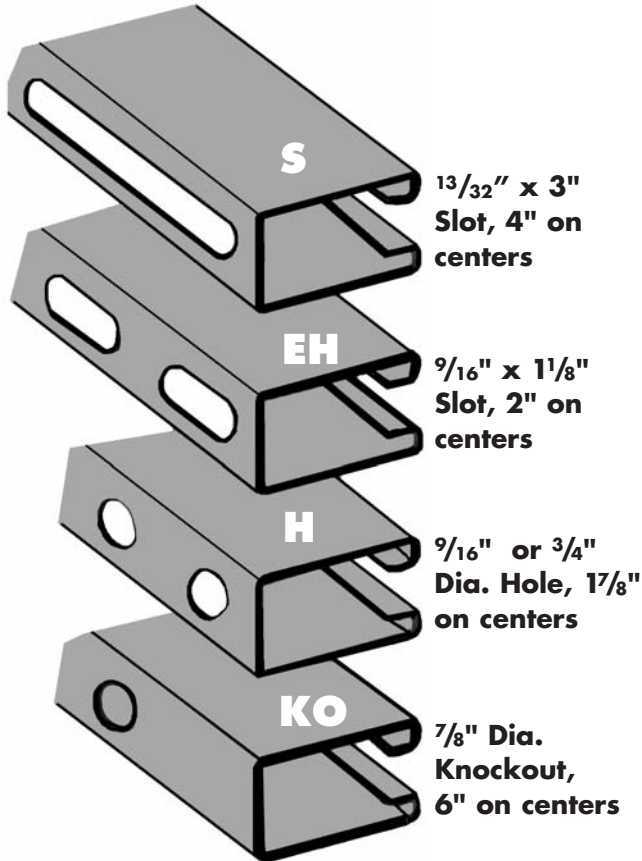

S CHANNEL			
Catalog #	Gauge	Dimensions	Wt./C Ft.
AS 100S	12	3 1/4 x 1 5/8	298#
AS 150S	12	2 7/16 x 1 5/8	239#
AS 200S	12	1 5/8 x 1 5/8	179#
AS 210S	14	1 5/8 x 1 5/8	130#
AS 300S	12	1 3/8 x 1 5/8	161#
AS 400S	12	1 x 1 5/8	134#
AS 520S	12	1 3/16 x 1 5/8	125#
AS 500S	14	1 3/16 x 1 5/8	94#

H 9/16 CHANNEL			
Catalog #	Gauge	Dimensions	Wt./C Ft.
AS 100H	12	3 1/4 x 1 5/8	308#
AS 150H	12	2 7/16 x 1 5/8	249#
AS 200H	12	1 5/8 x 1 5/8	189#
AS 210H	14	1 5/8 x 1 5/8	140#
AS 300H	12	1 3/8 x 1 5/8	171#
AS 400H	12	1 x 1 5/8	144#
AS 520H	12	1 3/16 x 1 5/8	130#
AS 500H	14	1 3/16 x 1 5/8	98#

EH CHANNEL			
Catalog #	Gauge	Dimensions	Wt./C Ft.
AS 100EH	12	3 1/4 x 1 5/8	308#
AS 150EH	12	2 7/16 x 1 5/8	254#
AS 200EH	12	1 5/8 x 1 5/8	189#
AS 210EH	14	1 5/8 x 1 5/8	140#
AS 300EH	12	1 3/8 x 1 5/8	171#
AS 400EH	12	1 x 1 5/8	144#
AS 520EH	12	1 3/16 x 1 5/8	130#
AS 500EH	14	1 3/16 x 1 5/8	98#

KO CHANNEL			
Catalog #	Gauge	Dimensions	Wt./C Ft.
AS 100KO	12	3 1/4 x 1 5/8	313#
AS 150KO	12	2 7/16 x 1 5/8	254#
AS 200KO	12	1 5/8 x 1 5/8	194#
AS 210KO	14	1 5/8 x 1 5/8	145#
AS 300KO	12	1 3/8 x 1 5/8	176#
AS 400KO	12	1 x 1 5/8	149#
AS 520KO	12	1 3/16 x 1 5/8	135#
AS 500KO	14	1 3/16 x 1 5/8	103#

SECTION 1 – CHANNEL

WELDED COMBINATIONS

All welded combinations illustrated below are available in any of our Anvil-Strut™ channels, in any of the following material or finishes: Plain, Pre-Galvanized, Supr-Green or Stainless Steel.

Our welded channels are normally spotwelded with a maximum of 3 inches on center or MIG welded where spotwelding is not possible. Dimensions shown are for welded variations of the AS 200 channel.

NOTE: SLOTTED CHANNELS AVAILABLE IN ALL WELDED COMBINATIONS.

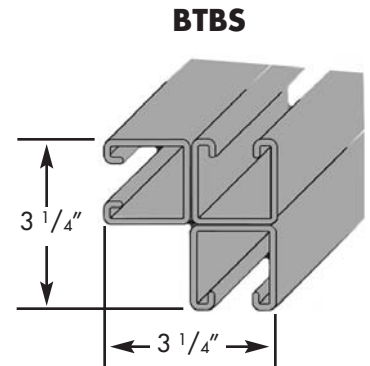
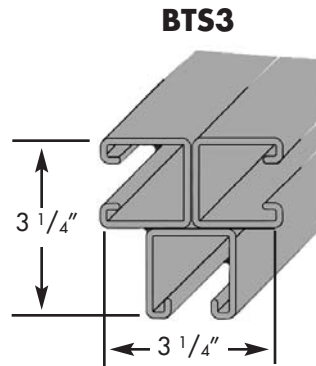
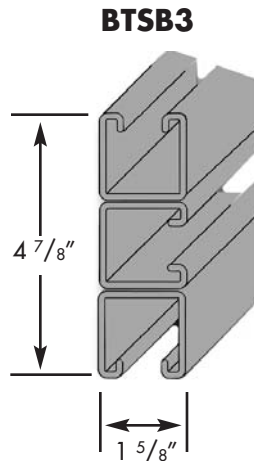
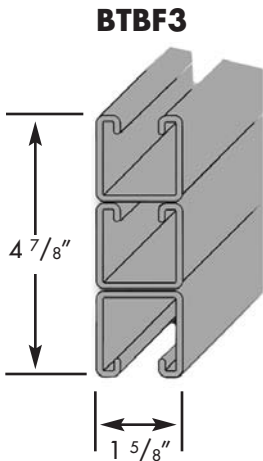
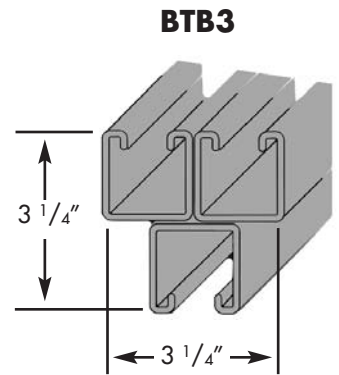
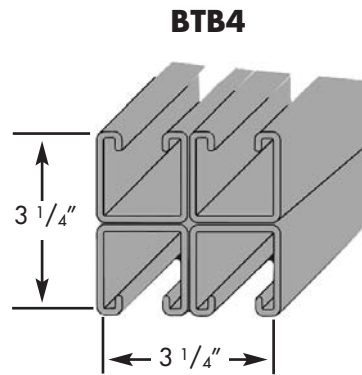
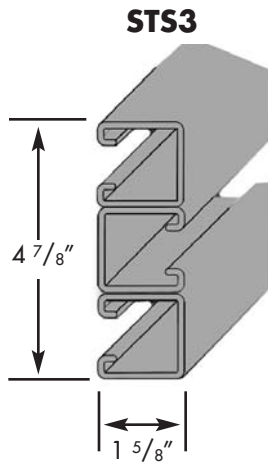
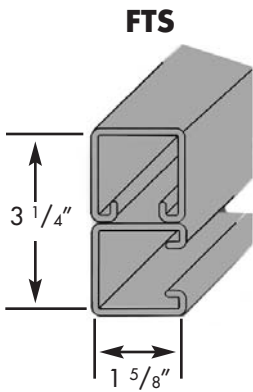
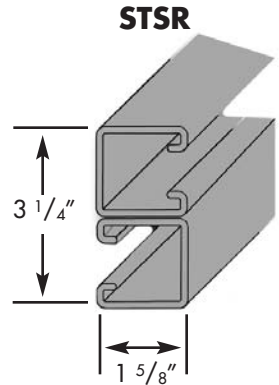
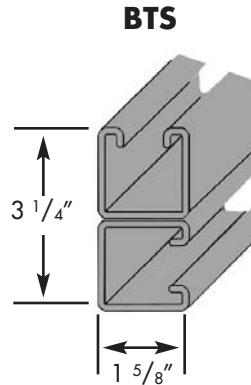
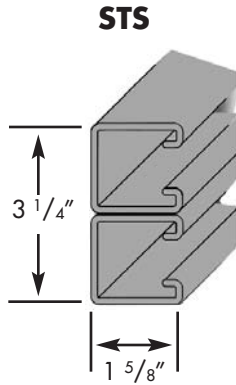
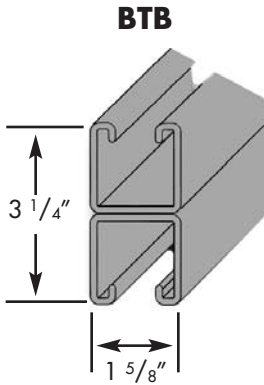

LEGEND:
GR: Painted Green
EG: Electro-Galvanized

PG: Pre-Galvanized
AL: Aluminum
HG: Hot Dipped Galvanized

PL: Plain
SS: Stainless Steel
ZD: Zinc Dichromate



SECTION 1 – CHANNEL

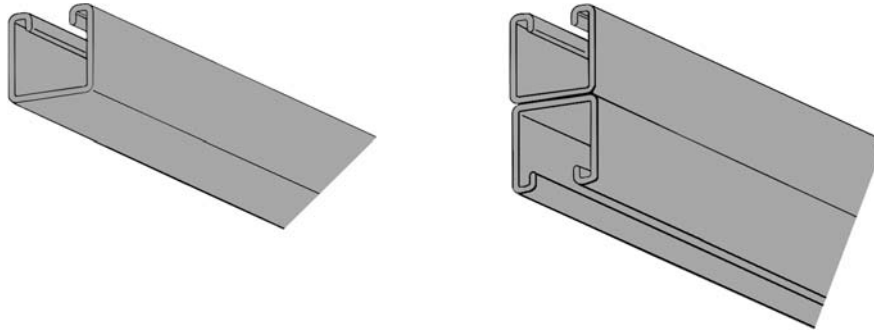

SPECIFICATIONS

GENERAL

Anvil-Strut™ channels are manufactured by a series of forming dies, or rolls, which progressively cold work the strip steel into the desired channel configuration. This method produces a cross section of uniform dimensions within a tolerance of plus or minus .015", on outside dimensions.

MATERIAL

Anvil-Strut™ channels are produced from prime structural steel covered by the following specifications.

PRE-GALVANIZED STEEL	ASTM A-653
PLAIN STEEL	ASTM A-570
ALUMINUM (Type 6063T6)	ASTM B-221
STAINLESS STEEL (Type 304 and 316)	ASTM A-240

(See technical section for additional information.)

Other materials and specifications available on request. Certification (C of C or CMTR's) if required must be requested at the time of ordering.

WELDING

Channel combinations of two or more elements are spotwelded together to form various multiple combinations. The spotwelds are spaced two or three inches on centers throughout the length of the multiple channel sections.

LENGTH INFORMATION

Anvil-Strut™ Channels are produced and stocked in 10 and 20 foot lengths with a tolerance of $\pm \frac{1}{8}$ ". Other lengths are available upon request.

FINISHES

All Anvil-Strut™ channels are stocked in pre-galvanized and painted supr-green. Some sizes are stocked in stainless steel, zinc dichromate, PVC coated or hot dipped galvanized. (See technical section for additional information.)

LOADING DATA

1. When calculating load at center of span, multiply uniform load from table by .5 and deflection by .8.
2. When calculating beam and column loads for aluminum, multiply by 33%.

BEAM AND COLUMN LOADING DATA

- * Not recommended - KL/r exceeds 200.
- ** For these loads, the uniform beam capacity is lower than the L/240 or L/360 beam capacity and is therefore the governing constraint.
- *** Load limited by spotweld shear.

NOTES

1. The beam capacities shown above include the weight of the strut beam. The beam weight must be subtracted from these capacities to arrive at the net beam capacity.
2. Allowable beam loads are based on a uniformly loaded, simply supported beam.
3. The load chart shows beam capacities for strut without holes. For strut with holes, multiply by the following: KO by 82%, H $\frac{3}{4}$ by 85%, H $\frac{9}{16}$ by 88%, EH by 88%, S by 90%.

SECTION 1 – CHANNEL

AS 100 BEAM AND COLUMN LOADS

Span or Column (In.)	Anvil-Strut™ Catalog No.	Max Load of Column Loaded @ C.G. (Lbs.)	Static Beam Load (X-X Axis)			
			Allowable Uniform Load @ 25,000 PSI (Lbs.)	Deflection @ 25,000 PSI (In.)	Uniform Load @ L/240 (Lbs.)	Uniform Load @ L/360 (Lbs.)
12	AS 100	12,428	10,155	0.007	**	**
	AS 100 BTB	26,291	5,130 ***	0.004	**	**
18	AS 100	11,161	6,770	0.016	**	**
	AS 100 BTB	25,442	5,130 ***	0.009	**	**
24	AS 100	9,531	5,077	0.029	**	**
	AS 100 BTB	24,359	5,130 ***	0.016	**	**
30	AS 100	7,642	4,062	0.045	**	**
	AS 100 BTB	23,122	5,130 ***	0.025	**	**
36	AS 100	5,767	3,385	0.065	**	**
	AS 100 BTB	21,805	5,130 ***	0.036	**	**
42	AS 100	4,550	2,901	0.088	**	**
	AS 100 BTB	20,472	5,130 ***	0.049	**	**
48	AS 100	3,754	2,539	0.115	**	**
	AS 100 BTB	19,169	5,130 ***	0.064	**	**
60	AS 100	2,803	2,031	0.180	**	1,876
	AS 100 BTB	16,771	5,130 ***	0.099	**	**
72	AS 100	2,268	1,692	0.260	**	1,303
	AS 100 BTB	14,733	5,130 ***	0.143	**	**
84	AS 100	1,927	1,451	0.354	1,436	957
	AS 100 BTB	13,073	4,515	0.195	**	**
96	AS 100	1,688	1,269	0.462	1,099	733
	AS 100 BTB	11,917	3,950	0.254	**	**
108	AS 100	1,509	1,128	0.585	869	579
	AS 100 BTB	9,933	3,512	0.322	**	3,272
120	AS 100	1,366	1,015	0.722	703	469
	AS 100 BTB	8,046	3,160	0.398	**	2,650
180	AS 100	*	677	1.624	313	208
	AS 100 BTB	*	2,107	0.894	1,767	1,178
240	AS 100	*	508	2.887	176	117
	AS 100 BTB	*	1,580	1.590	994	662

For Beam and Column Loading Data and load reduction information for channel with holes and concentrated loads, see notes on page 4.

AS 100

3 1/4" x 1 5/8"

12 Gauge Channel —
wt./100 ft. - 313#

Stocked in pre-galvanized, plain and painted supr-green, in both 10 and 20 ft. lengths. Other materials, finishes and lengths are available upon request.

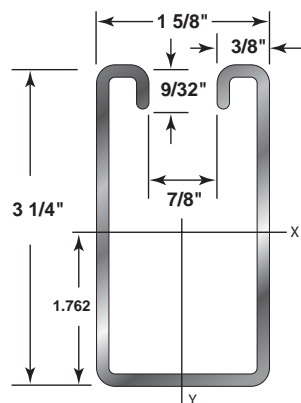

PROPERTIES OF SECTION

	Wt./Ft. Lbs.	Area of Section Sq. In.	X-X Axis			Y-Y Axis		
			I in ⁴	S in ³	r in.	I in ⁴	S in ³	r in.
AS 100	3.13	0.844	1.073	0.609	1.102	0.429	0.529	0.697
AS 100BTB	6.26	1.768	6.064	1.896	1.852	0.859	1.057	0.697

I = Moment of Inertia S = Section Modulus r = Radius of Gyration

AS 100BTB

6 1/2" x 1 5/8"

12 Gauge Back-to-Back
wt./100 ft. - 626#

Stocked in pre-galvanized, plain and painted supr-green, in both 10 and 20 ft. lengths. Other materials, finishes and lengths are available upon request.

See page 3 for welded combinations.

NOTE: BOTH ARE ALSO AVAILABLE IN STAINLESS STEEL 304 AND 316 ALLOYS.

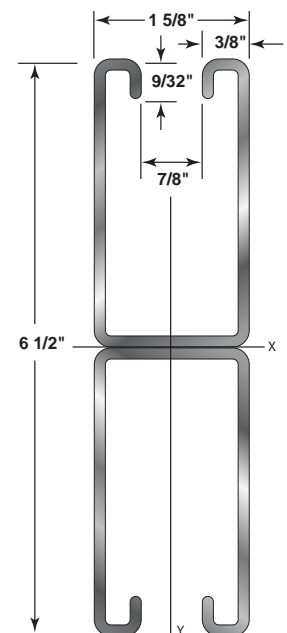

SECTION 1 – CHANNEL

AS 150 BEAM AND COLUMN LOADS

Span or Column (In.)	Anvil-Strut™ Catalog No.	Max Load of Column Loaded @ C.G. (Lbs.)	Static Beam Load (X-X Axis)			
			Allowable Uniform Load @ 25,000 PSI (Lbs.)	Deflection @ 25,000 PSI (In.)	Uniform Load @ L/240 (Lbs.)	Uniform Load @ L/360 (Lbs.)
12	AS 150	9,774	6,305	0.009	**	**
	AS 150 BTB	20,586	3,880 ***	0.005	**	**
18	AS 150	8,861	4,203	0.021	**	**
	AS 150 BTB	19,931	3,880 ***	0.012	**	**
24	AS 150	7,744	3,152	0.038	**	**
	AS 150 BTB	19,144	3,880 ***	0.021	**	**
30	AS 150	6,524	2,522	0.059	**	**
	AS 150 BTB	18,304	3,880 ***	0.033	**	**
36	AS 150	5,275	2,102	0.085	**	**
	AS 150 BTB	17,474	3,880 ***	0.048	**	**
42	AS 150	4,284	1,801	0.116	**	**
	AS 150 BTB	16,693	3,880 ***	0.065	**	**
48	AS 150	3,629	1,576	0.151	**	1,390
	AS 150 BTB	15,981	3,880 ***	0.085	**	**
60	AS 150	2,824	1,261	0.236	**	890
	AS 150 BTB	14,790	3,803	0.133	**	**
72	AS 150	2,346	1,051	0.340	**	618
	AS 150 BTB	13,881	3,169	0.192	**	**
84	AS 150	2,021	901	0.463	**	454
	AS 150 BTB	12,054	2,716	0.261	**	2,427
96	AS 150	1,778	788	0.605	**	347
	AS 150 BTB	9,409	2,377	0.341	**	1,858
108	AS 150	1,584	701	0.765	**	275
	AS 150 BTB	7,434	2,113	0.431	**	1,468
120	AS 150	1,422	630	0.945	**	222
	AS 150 BTB	6,022	1,901	0.532	**	1,189
180	AS 150	*	420	2.126	**	99
	AS 150 BTB	*	1,268	1.199	**	529
240	AS 150	*	315	3.780	**	56
	AS 150 BTB	*	951	2.131	**	297

For Beam and Column Loading Data and load reduction information for channel with holes and concentrated loads, see notes on page 4.

AS 150

27/16" x 15/8"

12 Gauge Channel
wt./100 ft. - 254#

Stocked in pre-galvanized, plain and painted supr-green, in both 10 and 20 ft. lengths. Other materials, finishes and lengths are available upon request.

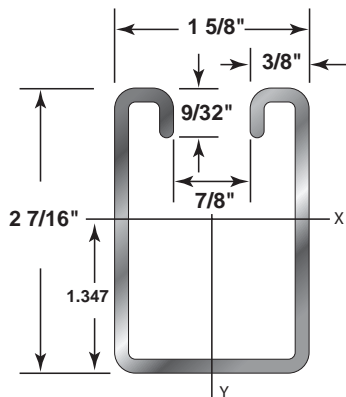

PROPERTIES OF SECTION								
Wt./Ft. Lbs.	Area of Section Sq. In.	X-X Axis			Y-Y Axis			
		I in ⁴	S in ³	r in.	I in ⁴	S in ³	r in.	
AS 150	2.54	0.714	0.509	0.378	0.844	0.331	0.408	0.681
AS 150BTB	5.08	1.428	2.721	1.141	1.381	0.663	0.815	0.681

I = Moment of Inertia S = Section Modulus r = Radius of Gyration

AS 150BTB

47/8" x 15/8"

12 Gauge Back-to-Back
wt./100 ft. - 508#

Stocked in pre-galvanized, plain and painted supr-green, in both 10 and 20 ft. lengths. Other materials, finishes and lengths are available upon request.

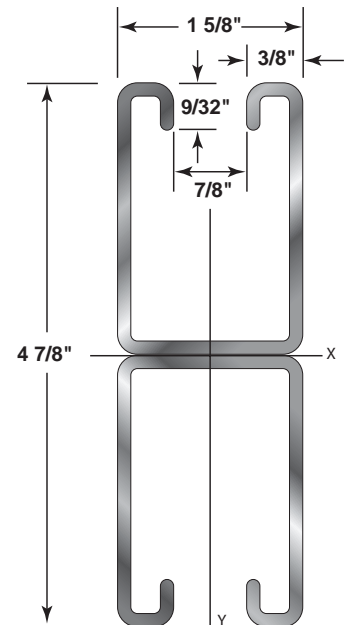

See page 3 for welded combinations.

NOTE: BOTH ARE ALSO AVAILABLE IN STAINLESS STEEL 304 AND 316 ALLOYS.

SECTION 1 – CHANNEL

AS 200 BEAM AND COLUMN LOADS

Span or Column (In.)	Anvil-Strut™ Catalog No.	Max Load of Column Loaded @ C.G. (Lbs.)	Static Beam Load (X-X Axis)			
			Allowable Uniform Load @ 25,000 PSI (Lbs.)	Deflection @ 25,000 PSI (In.)	Uniform Load @ L/240 (Lbs.)	Uniform Load @ L/360 (Lbs.)
12	AS 200	7,109	3,249	0.014	**	**
	AS 200 BTB	14,862	2,610 ***	0.008	**	**
18	AS 200	6,549	2,166	0.031	**	**
	AS 200 BTB	14,402	2,610 ***	0.018	**	**
24	AS 200	5,938	1,625	0.055	**	**
	AS 200 BTB	13,919	2,610 ***	0.032	**	**
30	AS 200	5,337	1,300	0.086	**	1,257
	AS 200 BTB	13,473	2,610 ***	0.050	**	**
36	AS 200	4,771	1,083	0.124	**	873
	AS 200 BTB	13,090	2,610 ***	0.072	**	**
42	AS 200	4,242	928	0.169	**	641
	AS 200 BTB	12,771	2,610 ***	0.099	**	**
48	AS 200	3,745	812	0.220	737	491
	AS 200 BTB	12,511	1,374	0.129	**	**
60	AS 200	3,012	650	0.344	471	314
	AS 200 BTB	11,685	1,899	0.202	**	1,566
72	AS 200	2,514	542	0.496	327	218
	AS 200 BTB	10,078	1,582	0.291	**	1,087
84	AS 200	2,136	464	0.675	240	160
	AS 200 BTB	8,180	1,356	0.396	1,199	799
96	AS 200	1,834	406	0.882	184	123
	AS 200 BTB	6,291	1,187	0.517	917	611
108	AS 200	1,585	361	1.116	145	97
	AS 200 BTB	4,971	1,055	0.655	725	483
120	AS 200	*	325	1.378	117	78
	AS 200 BTB	4,026	949	0.808	587	391
180	AS 200	*	217	3.099	52	35
	AS 200 BTB	*	633	1.819	261	174
240	AS 200	*	163	5.510	29	19
	AS 200 BTB	*	474	3.233	147	98

For Beam and Column Loading Data and load reduction information for channel with holes and concentrated loads, see notes on page 4.

AS 200

1 5/8" x 1 5/8"

12 Gauge Channel
wt./100 ft. - 194#

Stocked in pre-galvanized, plain and painted supr-green, in both 10 and 20 ft. lengths. Other materials, finishes and lengths are available upon request.

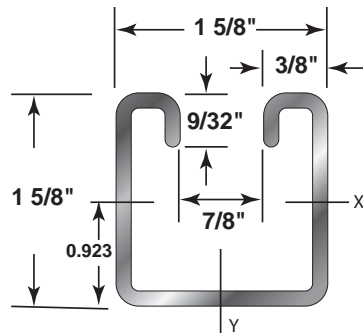

PROPERTIES OF SECTION

	Wt./Ft. Lbs.	Area of Section Sq. In.	X-X Axis			Y-Y Axis		
			I in ⁴	S in ³	r in.	I in ⁴	S in ³	r in.
AS 200	1.94	0.544	0.180	0.195	0.575	0.233	0.287	0.655
AS 200BTB	3.88	1.088	0.896	0.570	0.908	0.466	0.574	0.655

I = Moment of Inertia S = Section Modulus r = Radius of Gyration

AS 200BTB

3 1/4" x 1 5/8"

12 Gauge Back-to-Back
wt./100 ft. - 388#

Stocked in pre-galvanized, plain and painted supr-green, in both 10 and 20 ft. lengths. Other materials, finishes and lengths are available upon request.

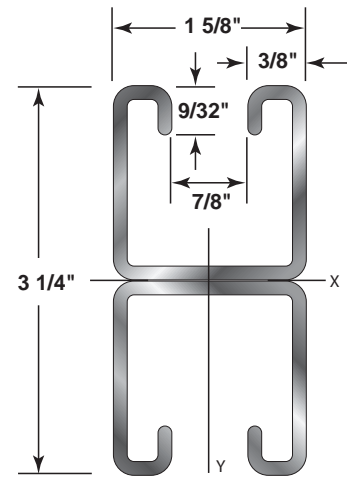

See page 3 for welded combinations.

NOTE: BOTH ARE ALSO AVAILABLE IN STAINLESS STEEL 304 AND 316 ALLOYS.

SECTION 1 – CHANNEL

AS 210 BEAM AND COLUMN LOADS

Span or Column (In.)	Anvil-Strut™ Catalog No.	Max Load of Column Loaded @ C.G. (Lbs.)	Static Beam Load (X-X Axis)			
			Allowable Uniform Load @ 25,000 PSI (Lbs.)	Deflection @ 25,000 PSI (In.)	Uniform Load @ L/240 (Lbs.)	Uniform Load @ L/360 (Lbs.)
12	AS 210	5,548	2,631	0.014	**	**
	AS 210 BTB	11,600	1,750 ***	0.008	**	**
18	AS 210	5,066	1,754	0.032	**	**
	AS 210 BTB	11,210	1,750 ***	0.018	**	**
24	AS 210	4,473	1,316	0.056	**	**
	AS 210 BTB	10,738	1,750 ***	0.032	**	**
30	AS 210	3,817	1,052	0.088	**	1,001
	AS 210 BTB	10,230	1,750 ***	0.050	**	**
36	AS 210	3,141	877	0.126	**	695
	AS 210 BTB	9,722	1,750 ***	0.072	**	**
42	AS 210	2,546	752	0.172	**	511
	AS 210 BTB	9,239	1,750 ***	0.098	**	**
48	AS 210	2,148	658	0.224	587	391
	AS 210 BTB	8,796	1,750 ***	0.128	**	**
60	AS 210	1,659	526	0.350	376	250
	AS 210 BTB	8,046	1,482	0.200	**	1,234
72	AS 210	1,370	439	0.504	261	174
	AS 210 BTB	7,466	1,235	0.288	**	857
84	AS 210	1,174	376	0.687	192	128
	AS 210 BTB	6,528	1,058	0.392	944	629
96	AS 210	1,028	329	0.897	147	98
	AS 210 BTB	5,042	926	0.512	723	482
108	AS 210	911	292	1.135	116	77
	AS 210 BTB	3,983	823	0.649	571	381
120	AS 210	*	263	1.401	94	63
	AS 210 BTB	3,227	741	0.801	463	308
180	AS 210	*	175	3.153	42	28
	AS 210 BTB	1,434	494	1.802	206	137
240	AS 210	*	132	5.605	23	16
	AS 210 BTB	*	370	3.203	116	77

For Beam and Column Loading Data and load reduction information for channel with holes and concentrated loads, see notes on page 4.

AS 210

1 5/8" x 1 5/8"

14 Gauge Channel
wt./100 ft. - 145#

Stocked in pre-galvanized, plain and painted sup-green, in both 10 and 20 ft. lengths. Other materials, finishes and lengths are available upon request.

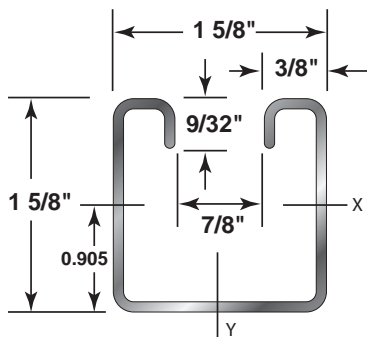

AS 210BTB

3 1/4" x 1 5/8"

14 Gauge Back-to-Back
wt./100 ft. - 290#

Stocked in pre-galvanized, plain and painted sup-green, in both 10 and 20 ft. lengths. Other materials, finishes and lengths are available upon request.

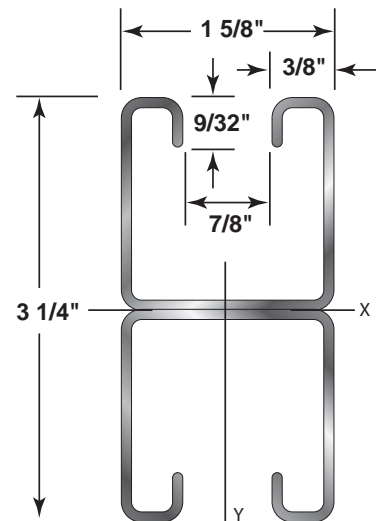

See page 3 for welded combinations.

NOTE: BOTH ARE ALSO AVAILABLE IN STAINLESS STEEL 304 AND 316 ALLOYS.

PROPERTIES OF SECTION								
Wt./Ft. Lbs.	Area of Section Sq. In.	X-X Axis			Y-Y Axis			
		I in ⁴	S in ³	r in.	I in ⁴	S in ³	r in.	
AS 210	1.45	0.407	0.143	0.158	0.593	0.179	0.221	0.664
AS 210BTB	2.90	0.814	0.706	0.445	0.931	0.359	0.441	0.664

I = Moment of Inertia S = Section Modulus r = Radius of Gyration

SECTION 1 – CHANNEL

AS 300 BEAM AND COLUMN LOADS

Span or Column (In.)	Anvil-Strut™ Catalog No.	Max Load of Column Loaded @ C.G. (Lbs.)	Static Beam Load (X-X Axis)			
			Allowable Uniform Load @ 25,000 PSI (Lbs.)	Deflection @ 25,000 PSI (In.)	Uniform Load @ L/240 (Lbs.)	Uniform Load @ L/360 (Lbs.)
12	AS 300	6,286	2,473	0.016	**	**
	AS 300 BTB	13,094	2,210 ***	0.010	**	**
18	AS 300	5,835	1,649	0.036	**	**
	AS 300 BTB	12,695	2,210 ***	0.022	**	**
24	AS 300	5,371	1,236	0.064	**	**
	AS 300 BTB	12,310	2,210 ***	0.038	**	**
30	AS 300	4,935	989	0.100	**	820
	AS 300 BTB	11,979	2,210 ***	0.060	**	**
36	AS 300	4,533	824	0.145	**	570
	AS 300 BTB	11,713	2,210 ***	0.086	**	**
42	AS 300	4,157	707	0.197	628	419
	AS 300 BTB	11,503	2,053	0.118	**	2,035
48	AS 300	3,795	618	0.257	481	320
	AS 300 BTB	11,338	1,797	0.154	**	1,558
60	AS 300	3,094	495	0.402	308	205
	AS 300 BTB	10,191	1,437	0.240	**	997
72	AS 300	2,551	413	0.579	214	142
	AS 300 BTB	8,718	1,198	0.346	1,039	692
84	AS 300	2,131	353	0.788	157	105
	AS 300 BTB	6,978	1,027	0.471	763	509
96	AS 300	1,797	309	1.029	120	80
	AS 300 BTB	5,347	898	0.615	584	389
108	AS 300	*	275	1.302	95	63
	AS 300 BTB	4,225	799	0.778	462	308
120	AS 300	*	247	1.608	77	51
	AS 300 BTB	3,422	719	0.961	374	249
180	AS 300	*	165	3.618	34	23
	AS 300 BTB	*	479	2.162	166	111
240	AS 300	*	124	6.431	19	13
	AS 300 BTB	*	359	3.844	93	62

For Beam and Column Loading Data and load reduction information for channel with holes and concentrated loads, see notes on page 4.

AS 300

1 3/8" x 1 5/8"

12 Gauge Channel
wt./100 ft. - 176#

Stocked in pre-galvanized, plain and painted sup-green, in both 10 and 20 ft. lengths. Other materials, finishes and lengths are available upon request.

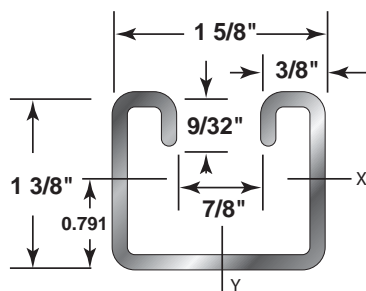

PROPERTIES OF SECTION								
	Wt./Ft. Lbs.	Area of Section Sq. In.	X-X Axis			Y-Y Axis		
			I in ⁴	S in ³	r in.	I in ⁴	S in ³	r in.
AS 300	1.76	0.492	0.117	0.148	0.489	0.203	0.250	0.642
AS 300BTB	3.52	0.983	0.570	0.431	0.762	0.406	0.499	0.642

I = Moment of Inertia S = Section Modulus r = Radius of Gyration

AS 300BTB

2 3/4" x 1 5/8"

12 Gauge Back-to-Back
wt./100 ft. - 352#

Stocked in pre-galvanized, plain and painted sup-green, in both 10 and 20 ft. lengths. Other materials, finishes and lengths are available upon request.

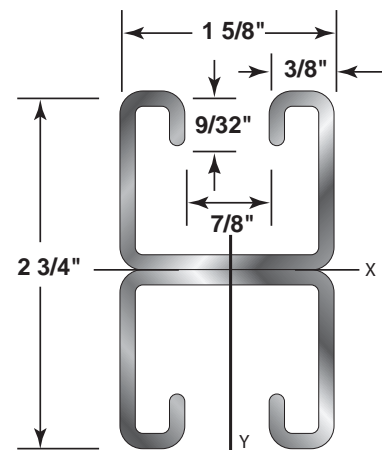

See page 3 for welded combinations.

NOTE: BOTH ARE ALSO AVAILABLE IN STAINLESS STEEL 304 AND 316 ALLOYS.

SECTION 1 – CHANNEL

AS 400 BEAM AND COLUMN LOADS

Span or Column (In.)	Anvil-Strut™ Catalog No.	Max Load of Column Loaded @ C.G. (Lbs.)	Static Beam Load (X-X Axis)			
			Allowable Uniform Load @ 25,000 PSI (Lbs.)	Deflection @ 25,000 PSI (In.)	Uniform Load @ L/240 (Lbs.)	Uniform Load @ L/360 (Lbs.)
12	AS 400	5,046	1,460	0.022	**	**
	AS 400 BTB	10,430	1,590 ***	0.013	**	**
18	AS 400	4,757	973	0.049	**	**
	AS 400 BTB	10,134	1,590 ***	0.030	**	**
24	AS 400	4,496	730	0.086	**	564
	AS 400 BTB	9,897	1,590 ***	0.054	**	**
30	AS 400	4,264	584	0.135	541	361
	AS 400 BTB	9,723	1,590 ***	0.084	**	1,698 **
36	AS 400	4,047	487	0.194	376	251
	AS 400 BTB	9,599	1,423	0.121	**	1,179
42	AS 400	3,831	417	0.264	276	184
	AS 400 BTB	9,420	1,220	0.164	**	866
48	AS 400	3,604	365	0.345	211	141
	AS 400 BTB	8,984	1,067	0.215	995	663
60	AS 400	3,089	292	0.540	135	90
	AS 400 BTB	7,940	854	0.335	637	424
72	AS 400	*	243	0.777	94	63
	AS 400 BTB	6,664	712	0.483	442	295
84	AS 400	*	209	1.058	69	46
	AS 400 BTB	5,167	610	0.657	325	217
96	AS 400	*	183	1.381	53	35
	AS 400 BTB	3,956	534	0.858	249	166
108	AS 400	*	162	1.748	42	28
	AS 400 BTB	*	474	1.086	197	131
120	AS 400	*	146	2.158	34	23
	AS 400 BTB	*	427	1.341	159	106
180	AS 400	*	97	4.857	15	10
	AS 400 BTB	*	285	3.018	71	47
240	AS 400	*	73	8.634	8	6
	AS 400 BTB	*	213	5.364	40	27

For Beam and Column Loading Data and load reduction information for channel with holes and concentrated loads, see notes on page 4.

AS 400

1" x 1 5/8"

12 Gauge Channel
wt./100 ft. - 149#

Stocked in pre-galvanized, plain and painted sup-green, in both 10 and 20 ft. lengths. Other materials, finishes and lengths are available upon request.

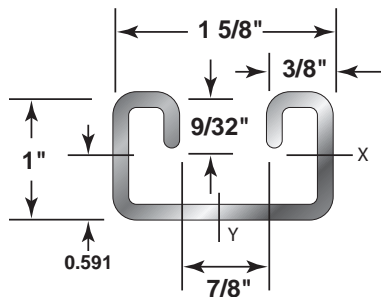

AS 400BTB

2" x 1 5/8"

12 Gauge Back-to-Back
wt./100 ft. - 298#

Stocked in pre-galvanized, plain and painted sup-green, in both 10 and 20 ft. lengths. Other materials, finishes and lengths are available upon request.

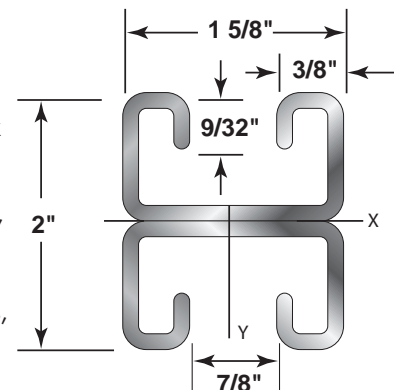

See page 3 for welded combinations.

NOTE: BOTH ARE ALSO AVAILABLE IN STAINLESS STEEL 304 AND 316 ALLOYS.

PROPERTIES OF SECTION								
Wt./Ft. Lbs.	Area of Section Sq. In.	X-X Axis			Y-Y Axis			
		I in ⁴	S in ³	r in.	I in ⁴	S in ³	r in.	
AS 400	1.49	0.413	0.052	0.088	0.353	0.157	0.194	0.617
AS 400BTB	2.98	0.826	0.243	0.256	0.542	0.315	0.388	0.617

I = Moment of Inertia S = Section Modulus r = Radius of Gyration

SECTION 1 – CHANNEL

AS 520 BEAM AND COLUMN LOADS

Span or Column (In.)	Anvil-Strut™ Catalog No.	Max Load of Column Loaded @ C.G. (Lbs.)	Static Beam Load (X-X Axis)			
			Allowable Uniform Load @ 25,000 PSI (Lbs.)	Deflection @ 25,000 PSI (In.)	Uniform Load @ L/240 (Lbs.)	Uniform Load @ L/360 (Lbs.)
12	AS 520	4,423	1,025	0.026	**	**
	AS 520 BTB	9,091	1,270 ***	0.017	**	**
18	AS 520	4,214	683	0.059	**	581
	AS 520 BTB	8,857	1,270 ***	0.038	**	**
24	AS 520	4,039	513	0.105	490	327
	AS 520 BTB	8,693	1,270 ***	0.067	**	**
30	AS 520	3,882	410	0.163	313	209
	AS 520 BTB	8,585	1,224	0.105	**	976
36	AS 520	3,727	342	0.235	218	145
	AS 520 BTB	8,513	1,020	0.150	1,017	678
42	AS 520	3,558	293	0.320	160	107
	AS 520 BTB	8,177	874	0.205	747	498
48	AS 520	3,369	256	0.419	122	81
	AS 520 BTB	7,774	765	0.267	572	381
60	AS 520	*	205	0.654	78	52
	AS 520 BTB	6,807	612	0.418	366	244
72	AS 520	*	171	0.941	54	36
	AS 520 BTB	5,625	510	0.602	254	169
84	AS 520	*	146	1.282	40	27
	AS 520 BTB	4,280	437	0.819	187	125
96	AS 520	*	128	1.674	31	21
	AS 520 BTB	*	382	1.070	143	95
108	AS 520	*	114	2.119	24	16
	AS 520 BTB	*	340	1.354	113	75
120	AS 520	*	103	2.616	20	13
	AS 520 BTB	*	306	1.672	91	61
180	AS 520	*	68	5.887	9	6
	AS 520 BTB	*	204	3.762	41	27
240	AS 520	*	51	10.465	5	3
	AS 520 BTB	*	153	6.689	23	15

For Beam and Column Loading Data and load reduction information for channel with holes and concentrated loads, see notes on page 4.

AS 520
13/16" x 15/8"
12 Gauge Channel
wt./100 ft. - 135#

Stocked in pre-galvanized, plain and painted supr-green, in both 10 and 20 ft. lengths. Other materials, finishes and lengths are available upon request.

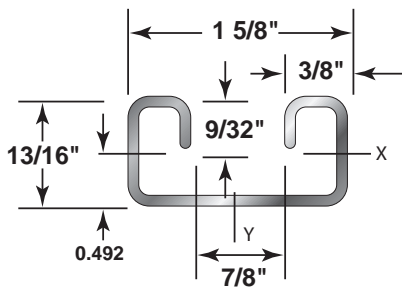

AS 520BTB
15/8" x 15/8"
12 Gauge Back-to-Back
wt./100 ft. - 270#

Stocked in pre-galvanized, plain and painted supr-green, in both 10 and 20 ft. lengths. Other materials, finishes and lengths are available upon request.

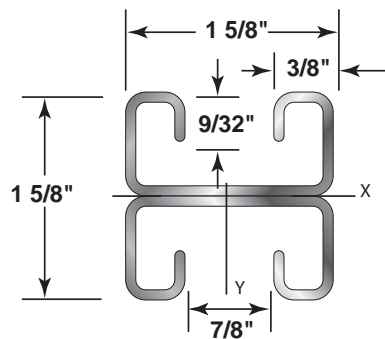

See page 3 for welded combinations.

NOTE: BOTH ARE ALSO AVAILABLE IN STAINLESS STEEL 304 AND 316 ALLOYS.

PROPERTIES OF SECTION								
Wt./Ft. Lbs.	Area of Section Sq. In.	X-X Axis			Y-Y Axis			
		I in ⁴	S in ³	r in.	I in ⁴	S in ³	r in.	
AS 520	1.374	0.374	0.030	0.062	0.283	0.135	0.166	0.600
AS 520BTB	2.700	0.748	0.140	0.184	0.432	0.270	0.332	0.600

I = Moment of Inertia S = Section Modulus r = Radius of Gyration

SECTION 1 – CHANNEL

AS 500 BEAM AND COLUMN LOADS

Span or Column (In.)	Anvil-Strut™ Catalog No.	Max Load of Column Loaded @ C.G. (Lbs.)	Static Beam Load (X-X Axis)			
			Allowable Uniform Load @ 25,000 PSI (Lbs.)	Deflection @ 25,000 PSI (In.)	Uniform Load @ L/240 (Lbs.)	Uniform Load @ L/360 (Lbs.)
12	AS 500	3,598	887	0.027	**	**
	AS 500 BTB	7,434	870 ***	0.016	**	**
18	AS 500	3,340	591	0.060	**	493
	AS 500 BTB	7,140	870 ***	0.037	**	**
24	AS 500	3,086	444	0.106	416	277
	AS 500 BTB	6,867	870 ***	0.066	**	**
30	AS 500	2,854	355	0.166	266	177
	AS 500 BTB	6,642	870 ***	0.102	**	806
36	AS 500	2,645	296	0.240	185	123
	AS 500 BTB	6,466	826	0.147	**	559
42	AS 500	2,449	254	0.327	136	91
	AS 500 BTB	6,331	708	0.201	617	411
48	AS 500	2,259	222	0.427	104	69
	AS 500 BTB	6,228	619	0.262	472	315
60	AS 500	*	177	0.667	66	44
	AS 500 BTB	5,648	496	0.410	302	201
72	AS 500	*	148	0.960	46	31
	AS 500 BTB	4,711	413	0.590	210	140
84	AS 500	*	127	1.037	34	23
	AS 500 BTB	3,623	354	0.803	154	103
96	AS 500	*	111	1.707	26	17
	AS 500 BTB	*	310	1.049	118	79
108	AS 500	*	99	2.160	21	14
	AS 500 BTB	*	275	1.328	93	62
120	AS 500	*	89	2.668	17	11
	AS 500 BTB	*	248	1.640	76	51
180	AS 500	*	59	6.003	7	5
	AS 500 BTB	*	165	3.689	34	23
240	AS 500	*	44	10.672	4	3
	AS 500 BTB	*	124	6.560	19	13

For Beam and Column Loading Data and load reduction information for channel with holes and concentrated loads, see notes on page 4.

AS 500

13/16" x 1 5/8"

14 Gauge Channel
wt./100 ft. - 103#

Stocked in pre-galvanized, plain and painted supr-green, in both 10 and 20 ft. lengths. Other materials, finishes and lengths are available upon request.

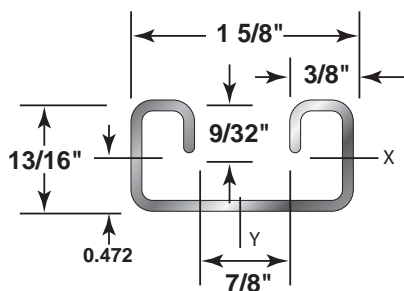

AS 500BTB

1 5/8" x 1 5/8"

14 Gauge Back-to-Back
wt./100 ft. - 206#

Stocked in pre-galvanized, plain and painted supr-green, in both 10 and 20 ft. lengths. Other materials, finishes and lengths are available upon request.

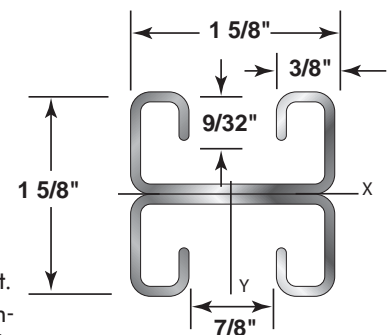

See page 3 for welded combinations.

NOTE: BOTH ARE ALSO AVAILABLE IN STAINLESS STEEL 304 AND 316 ALLOYS.

PROPERTIES OF SECTION								
Wt./Ft. Lbs.	Area of Section Sq. In.	X-X Axis			Y-Y Axis			
		I in ⁴	S in ³	r in.	I in ⁴	S in ³	r in.	
AS 500	1.03	0.286	0.025	0.053	0.298	0.106	0.131	0.610
AS 500BTB	2.06	0.571	0.115	0.149	0.449	0.213	0.262	0.610

I = Moment of Inertia S = Section Modulus r = Radius of Gyration

SECTION 1 – CHANNEL

AS 100 CHANNEL

1 5/8" x 3 1/4" x 12 Ga.

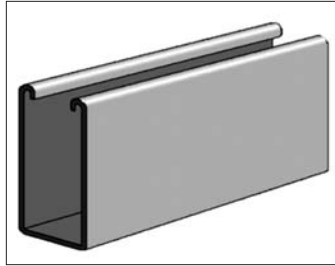

Discount Code A			Per 100 Ft.		
Part No.	Std. Pkg.	Wt.	PL	GR	PG
AS 100 10	300'	305	\$1,129.97	\$1,241.97	\$1,335.97
AS 100 20	600'	305	\$1,129.97	\$1,241.97	\$1,335.97

AS 100EH CHANNEL WITH ELONGATED HOLES

1 1/8" x 9/16" Elongated Holes
On 2" Centers
1 5/8" x 3 1/4" x 12 Ga.

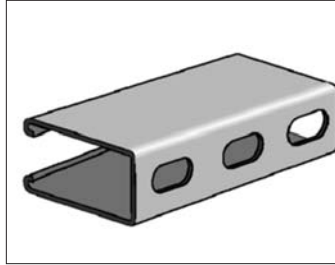

Discount Code A			Per 100 Ft.		
Part No.	Std. Pkg.	Wt.	PL	GR	PG
AS 100EH 10	300'	300	\$1,453.97	\$1,460.97	\$1,549.96
AS 100EH 20	600'	300	\$1,453.97	\$1,460.97	\$1,549.96

AS 100KO CHANNEL WITH KNOCK OUT

7/8" Knock Out On 6" Centers
1 5/8" x 3 1/4" x 12 Ga.

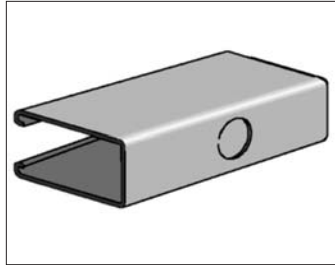

Discount Code A			Per 100 Ft.		
Part No.	Std. Pkg.	Wt.	PL	GR	PG
AS 100KO 10	300'	305	\$1,595.96	\$1,765.96	\$1,886.96
AS 100KO 20	600'	305	\$1,595.96	\$1,765.96	\$1,886.96

AS 100H CHANNEL WITH HOLES

9/16" Holes On 1 7/8" Centers
1 5/8" x 3 1/4" x 12 Ga.

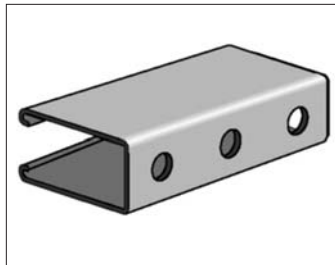

Discount Code A			Per 100 Ft.		
Part No.	Std. Pkg.	Wt.	PL	GR	PG
AS 100H 10	300'	300	\$1,608.96	\$1,793.96	\$1,917.96
AS 100H 20	600'	300	\$1,608.96	\$1,793.96	\$1,917.96

AS 100S CHANNEL WITH LONG SLOTS

1 3/32" x 3" Slots On 4" Centers
1 5/8" x 3 1/4" x 12 Ga.

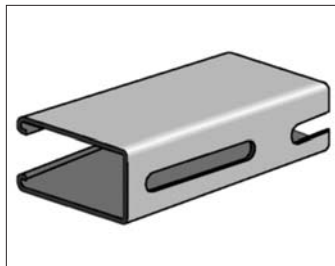

Discount Code A			Per 100 Ft.		
Part No.	Std. Pkg.	Wt.	PL	GR	PG
AS 100S 10	300'	300	\$1,620.96	\$1,795.96	\$1,920.96
AS 100S 20	600'	300	\$1,620.96	\$1,795.96	\$1,920.96

AS 100BTB WELDED CHANNEL

Two Pcs. AS 100 Welded Back To Back
1 5/8" x 6 1/2" x 12 Ga.

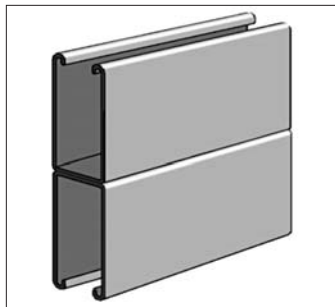

Discount Code A			Per 100 Ft.		
Part No.	Std. Pkg.	Wt.	PL	GR	PG
AS 100BTB 10	150'	610	\$3,032.93	\$3,356.92	\$3,649.92
AS 100BTB 20	200'	610	\$3,032.93	\$3,356.92	\$3,649.92

LEGEND:
GR: Painted Green
EG: Electro-Galvanized

PG: Pre-Galvanized
AL: Aluminum
HG: Hot Dipped Galvanized

PL: Plain
SS: Stainless Steel
ZD: Zinc Dichromate



SECTION 1 – CHANNEL

AS 150 CHANNEL

1⁵/₈" x 2⁷/₁₆" x 12 Ga.

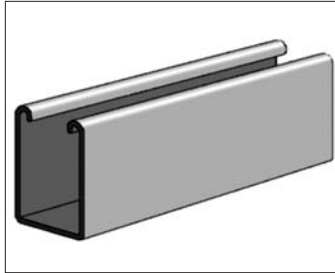

Discount Code A			Per 100 Ft.		
Part No.	Std. Pkg.	Wt.	PL	GR	PG
AS 150 10	400'	247	\$905.98	\$999.98	\$1,189.97
AS 150 20	800'	247	\$905.98	\$999.98	\$1,189.97

AS 150EH CHANNEL WITH ELONGATED HOLES

1¹/₈" x 9⁹/₁₆" Elongated Holes
 On 2" Centers
 1⁵/₈" x 2⁷/₁₆" x 12 Ga.

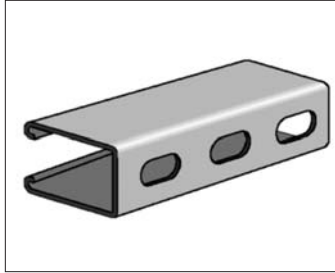

Discount Code A			Per 100 Ft.		
Part No.	Std. Pkg.	Wt.	PL	GR	PG
AS 150EH 10	400'	242	\$1,094.97	\$1,185.97	\$1,270.97
AS 150EH 20	800'	242	\$1,094.97	\$1,185.97	\$1,270.97

AS 150KO CHANNEL WITH KNOCK OUTS

7⁷/₈" Knock Outs On 6" Centers
 1⁵/₈" x 2⁷/₁₆" x 12 Ga.

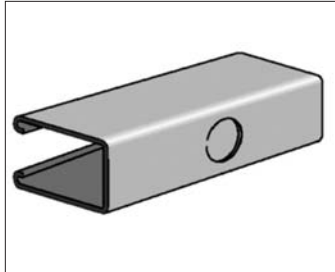

Discount Code A			Per 100 Ft.		
Part No.	Std. Pkg.	Wt.	PL	GR	PG
AS 150KO 10	400'	247	\$1,298.97	\$1,429.97	\$1,523.96
AS 150KO 20	800'	247	\$1,298.97	\$1,429.97	\$1,523.96

AS 150H CHANNEL WITH HOLES

9⁹/₁₆" Holes On 1⁷/₈" Centers
 1⁵/₈" x 2⁷/₁₆" x 12 Ga.

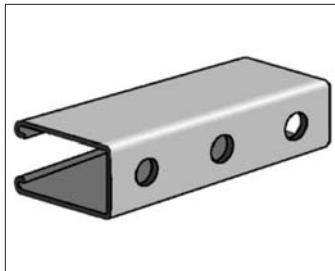

Discount Code A			Per 100 Ft.		
Part No.	Std. Pkg.	Wt.	PL	GR	PG
AS 150H 10	400'	242	\$1,305.97	\$1,438.97	\$1,525.96
AS 150H 20	800'	242	\$1,305.97	\$1,438.97	\$1,525.96

AS 150S CHANNEL WITH LONG SLOTS

1³/₃₂" x 3" Slots On 4" Centers
 1⁵/₈" x 2⁷/₁₆" x 12 Ga.

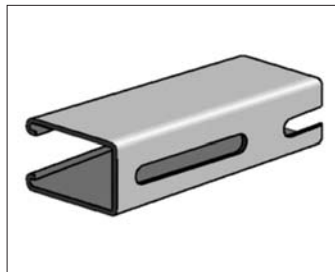

Discount Code A			Per 100 Ft.		
Part No.	Std. Pkg.	Wt.	PL	GR	PG
AS 150S 10	400'	242	\$1,293.97	\$1,447.97	\$1,525.96
AS 150S 20	800'	242	\$1,293.97	\$1,447.97	\$1,525.96

AS 150BTB WELDED CHANNEL

Two Pcs. AS 150 Welded Back To Back
 1⁵/₈" x 4⁷/₈" x 12 Ga.

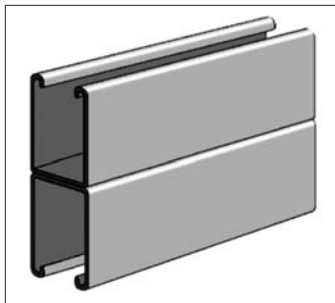

Discount Code A			Per 100 Ft.		
Part No.	Std. Pkg.	Wt.	PL	GR	PG
AS 150BTB 10	200'	484	\$2,420.39	\$2,465.94	\$2,651.94
AS 150BTB 20	200'	484	\$2,420.39	\$2,465.94	\$2,651.94

SECTION 1 – CHANNEL

AS 200 CHANNEL

1 5/8" x 1 5/8" x 12 Ga.

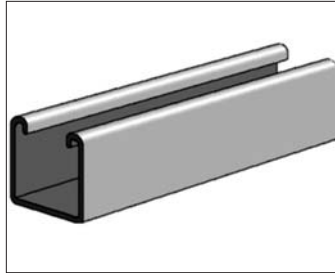

Discount Code A			Per 100 Ft.		
Part No.	Std. Pkg.	Wt.	PL	GR	PG
AS 200 10	500'	190	\$613.99	\$662.98	\$678.98
AS 200 20	500'	190	\$613.99	\$662.98	\$678.98

AS 200EH CHANNEL WITH ELONGATED HOLES

1 1/8" x 9/16" Elongated Holes
On 2" Centers
1 5/8" x 1 5/8" x 12 Ga.

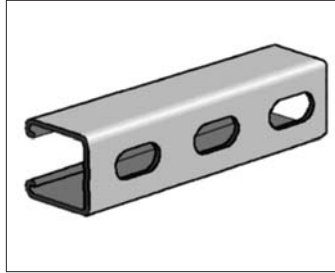

Discount Code A			Per 100 Ft.		
Part No.	Std. Pkg.	Wt.	PL	GR	PG
AS 200EH 10	500'	185	\$717.98	\$739.98	\$753.98
AS 200EH 20	500'	185	\$717.98	\$739.98	\$753.98

AS 200KO CHANNEL WITH KNOCK OUTS

7/8" Knock Outs On 6" Centers
1 5/8" x 1 5/8" x 12 Ga.

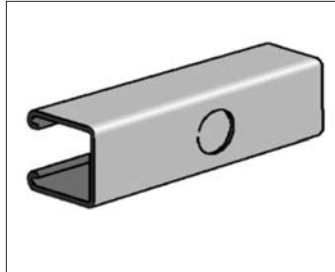

Discount Code A			Per 100 Ft.		
Part No.	Std. Pkg.	Wt.	PL	GR	PG
AS 200KO 10	500'	190	\$730.98	\$773.98	\$803.98
AS 200KO 20	500'	190	\$730.98	\$773.98	\$803.98

AS 200H CHANNEL WITH HOLES

9/16" Holes On 1 7/8" Centers
1 5/8" x 1 5/8" x 12 Ga.

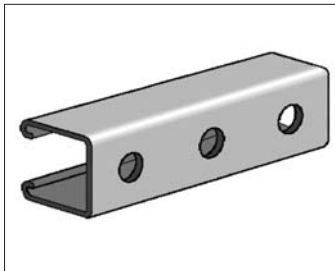

Discount Code A			Per 100 Ft.		
Part No.	Std. Pkg.	Wt.	PL	GR	PG
AS 200H 10	500'	186	\$730.98	\$764.98	\$767.98
AS 200H 20	500'	186	\$730.98	\$764.98	\$767.98

AS 200S CHANNEL WITH LONG SLOTS

1 3/32" x 3" Slots On 4" Centers
1 5/8" x 1 5/8" x 12 Ga.

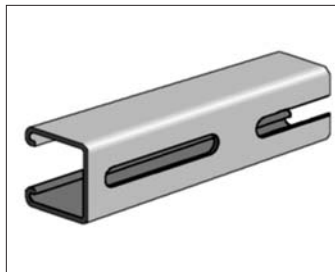

Discount Code A			Per 100 Ft.		
Part No.	Std. Pkg.	Wt.	PL	GR	PG
AS 200S 10	500'	185	\$734.98	\$746.98	\$777.98
AS 200S 20	500'	185	\$734.98	\$746.98	\$777.98

AS 200STSR WELDED CHANNEL

Two Pcs. AS 200 Welded Side To
Opposite Side
1 5/8" x 3 1/4" x 12 Ga.

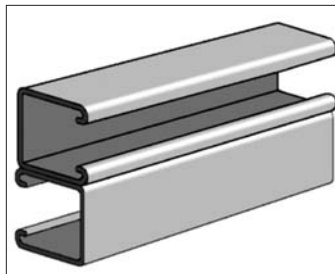

Discount Code A			Per 100 Ft.		
Part No.	Std. Pkg.	Wt.	PL	GR	PG
AS200STSR 10	250'	380	\$1,975.95	\$2,229.95	\$2,427.94
AS200STSR 20	300'	380	\$1,975.95	\$2,229.95	\$2,427.94

LEGEND:
GR: Painted Green
EG: Electro-Galvanized

PG: Pre-Galvanized
AL: Aluminum
HG: Hot Dipped Galvanized

PL: Plain
SS: Stainless Steel
ZD: Zinc Dichromate

SECTION 1 – CHANNEL

AS 200BTB WELDED CHANNEL

Two Pcs. AS 200 Welded Back To Back
 1 5/8" x 3 1/4" x 12 Ga.

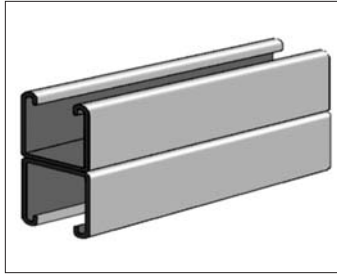

Discount Code A				Per 100 Ft.		
Part No.	Std. Pkg.	Wt.	PL	GR	PG	
AS 200BTB 10	250'	380	\$1,352.97	\$1,455.33	\$1,485.97	
AS 200BTB 20	300'	380	\$1,352.97	\$1,455.33	\$1,485.97	

AS 200BTS WELDED CHANNEL

Two Pcs. AS 200 Welded Side To Back
 1 5/8" x 3 1/4" x 12 Ga.

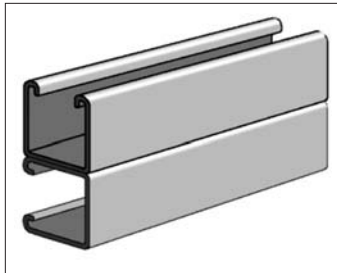

Discount Code A				Per 100 Ft.		
Part No.	Std. Pkg.	Wt.	PL	GR	PG	
AS 200BTS 10	250'	380	\$1,975.95	\$2,229.95	\$2,616.94	
AS 200BTS 20	300'	380	\$1,975.95	\$2,229.95	\$2,616.94	

AS 200STS WELDED CHANNEL

Two Pcs. AS 200 Welded Side To Side
 1 5/8" x 3 1/4" x 12 Ga.

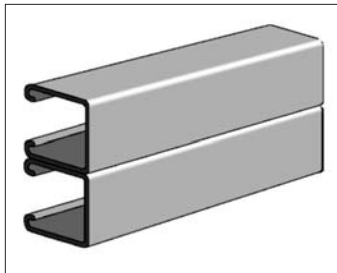

Discount Code A				Per 100 Ft.		
Part No.	Std. Pkg.	Wt.	PL	GR	PG	
AS 200STS 10	250'	380	\$1,975.95	\$2,229.95	\$2,427.94	
AS 200STS 20	300'	380	\$1,975.95	\$2,229.95	\$2,427.94	

AS 200BTBS WELDED CHANNEL

Three Pcs. AS 200
 Welded Side To Side
 3 1/4" x 3 1/4" x 12 Ga.

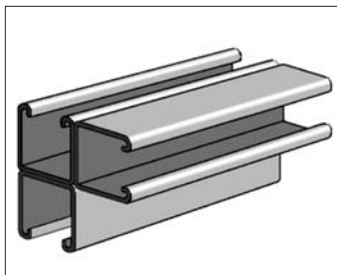

Discount Code A				Per 100 Ft.		
Part No.	Std. Pkg.	Wt.	PL	GR	PG	
AS200BTBS10	100'	570	\$5,068.88	\$5,410.88	\$6,765.84	
AS200BTBS20	200'	570	\$5,068.88	\$5,410.88	\$6,765.84	

AS 200BTBF3 WELDED CHANNEL

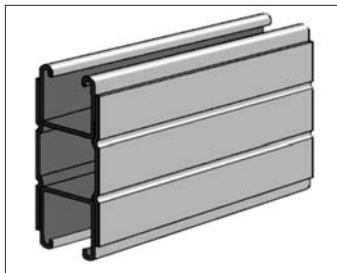

Discount Code A				Per 100 Ft.		
Part No.	Std. Pkg.	Wt.	PL	GR	PG	
AS200BTBF310	50'	670	\$6,756.84	\$7,097.84	\$8,662.80	
AS200BTBF320	100'	670	\$6,756.84	\$7,097.84	\$8,662.80	

SECTION 1 – CHANNEL

AS 210 CHANNEL

1 5/8" x 1 5/8" x 14 Ga.

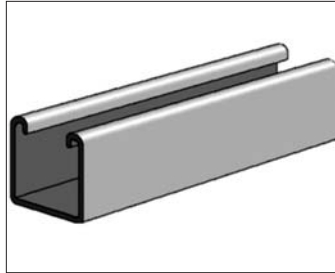

Discount Code A			Per 100 Ft.		
Part No.	Std. Pkg.	Wt.	PL	GR	PG
AS 210 10	500'	141	\$518.99	\$567.99	\$587.99
AS 210 20	500'	141	\$518.99	\$567.99	\$587.99

AS 210EH CHANNEL WITH ELONGATED HOLES

1 1/8" x 9/16" Elongated Holes
On 2" Centers
1 5/8" x 1 5/8" x 14 Ga.

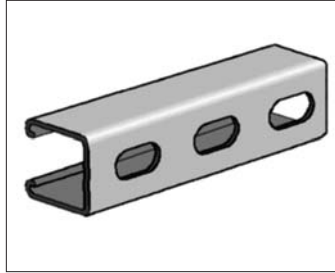

Discount Code A			Per 100 Ft.		
Part No.	Std. Pkg.	Wt.	PL	GR	PG
AS 210EH 10	500'	137	\$632.99	\$643.99	\$666.98
AS 210EH 20	500'	137	\$632.99	\$643.99	\$666.98

AS 210KO CHANNEL WITH KNOCK OUTS

7/8" Knock Outs On 6" Centers
1 5/8" x 1 5/8" x 14 Ga.

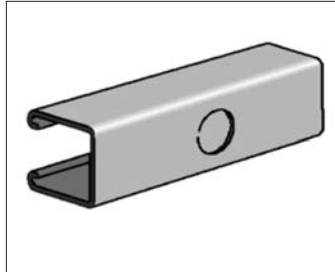

Discount Code A			Per 100 Ft.		
Part No.	Std. Pkg.	Wt.	PL	GR	PG
AS 210KO 10	500'	141	\$807.98	\$816.98	\$836.98
AS 210KO 20	500'	141	\$807.98	\$816.98	\$836.98

AS 210H STEEL CHANNEL WITH HOLES

9/16" Holes On 1 7/8" Centers
1 5/8" x 1 5/8" x 14 Ga.

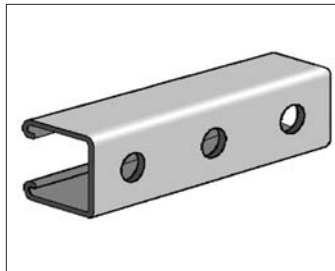

Discount Code A			Per 100 Ft.		
Part No.	Std. Pkg.	Wt.	PL	GR	PG
AS 210H 10	500'	137	\$739.98	\$821.98	\$826.98
AS 210H 20	500'	137	\$739.98	\$821.98	\$826.98

AS 210S CHANNEL WITH LONG SLOTS

1 3/32" x 3" Slots On 4" Centers
1 5/8" x 1 5/8" x 14 Ga.

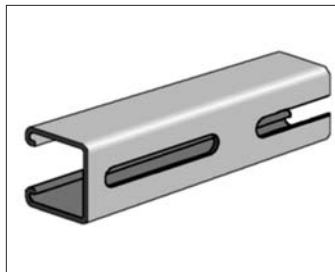

Discount Code A			Per 100 Ft.		
Part No.	Std. Pkg.	Wt.	PL	GR	PG
AS 210S 10	500'	137	\$699.98	\$705.98	\$784.98
AS 210S 20	500'	137	\$699.98	\$705.98	\$784.98

AS 210BTB WELDED CHANNEL

Two Pcs. AS 210 Welded
Back To Back
1 5/8" x 3 1/4" x 14 Ga.

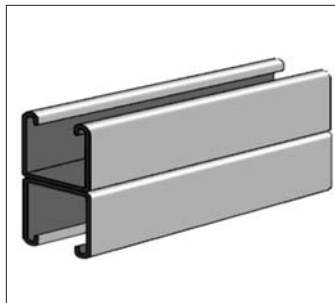

Discount Code A			Per 100 Ft.		
Part No.	Std. Pkg.	Wt.	PL	GR	PG
AS 210BTB 10	250'	282	\$1,434.97	\$1,633.96	\$1,661.96
AS 210BTB 20	300'	282	\$1,434.97	\$1,633.96	\$1,661.96

LEGEND:
GR: Painted Green
EG: Electro-Galvanized

PG: Pre-Galvanized
AL: Aluminum
HG: Hot Dipped Galvanized

PL: Plain
SS: Stainless Steel
ZD: Zinc Dichromate



CHANNEL

SECTION 1 – CHANNEL

AS 300 CHANNEL

1⁵/₈" x 1³/₈" x 12 Ga.

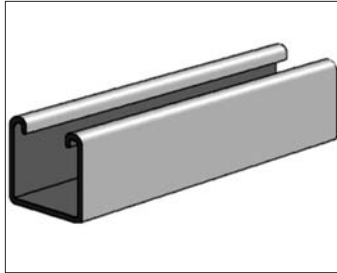

Discount Code A		Per 100 Ft.			
Part No.	Std. Pkg.	Wt.	PL	GR	PG
AS 300 10	500'	170	\$639.99	\$710.98	\$739.98
AS 300 20	500'	170	\$639.99	\$710.98	\$739.98

AS 300EH CHANNEL WITH ELONGATED HOLES

1¹/₈" x ⁹/₁₆" Elongated Holes
 On 2" Centers
 1⁵/₈" x 1³/₈" x 12 Ga.

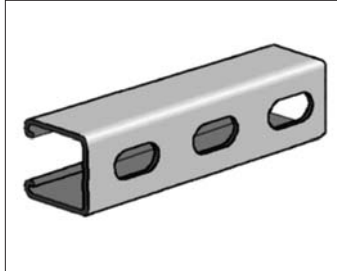

Discount Code A		Per 100 Ft.			
Part No.	Std. Pkg.	Wt.	PL	GR	PG
AS 300EH 10	500'	165	\$882.98	\$892.98	\$906.98
AS 300EH 20	500'	165	\$882.98	\$892.98	\$906.98

AS 300KO CHANNEL WITH KNOCK OUTS

⁷/₈" Knock Outs On 6" Centers
 1⁵/₈" x 1³/₈" x 12 Ga.

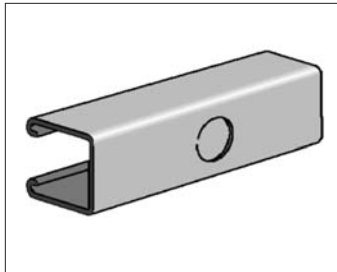

Discount Code A		Per 100 Ft.			
Part No.	Std. Pkg.	Wt.	PL	GR	PG
AS 300KO 10	500'	170	\$896.98	\$997.98	\$1,009.98
AS 300KO 20	500'	170	\$896.98	\$997.98	\$1,009.98

AS 300H CHANNEL WITH HOLES

⁹/₁₆" Holes On 1⁷/₈" Centers
 1⁵/₈" x 1³/₈" x 12 Ga.

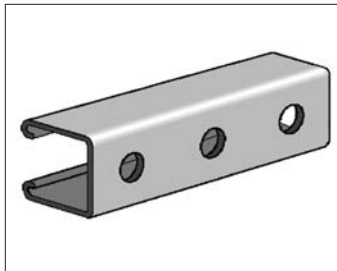

Discount Code A		Per 100 Ft.			
Part No.	Std. Pkg.	Wt.	PL	GR	PG
AS 300H 10	500'	165	\$907.98	\$953.98	\$1,011.98
AS 300H 20	500'	165	\$907.98	\$953.98	\$1,011.98

AS 300S CHANNEL WITH LONG SLOTS

¹³/₃₂" x 3" Slots On 4" Centers
 1⁵/₈" x 1³/₈" x 12 Ga.

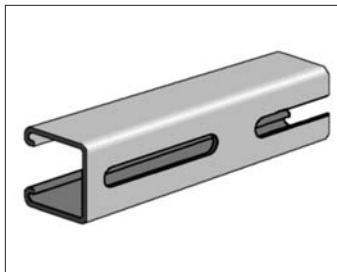

Discount Code A		Per 100 Ft.			
Part No.	Std. Pkg.	Wt.	PL	GR	PG
AS 300S 10	500'	165	\$899.98	\$997.98	\$1,012.98
AS 300S 20	500'	165	\$899.98	\$997.98	\$1,012.98

AS 300BTB WELDED CHANNEL

Two Pcs. AS 300 Welded Back To Back
 1⁵/₈" x 2³/₄" x 12 Ga.

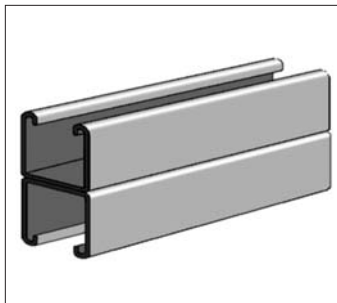

Discount Code A		Per 100 Ft.			
Part No.	Std. Pkg.	Wt.	PL	GR	PG
AS 300BTB 10	250'	340	\$1,558.96	\$1,717.96	\$1,763.96
AS 300BTB 20	300'	340	\$1,558.96	\$1,717.96	\$1,763.96

SECTION 1 – CHANNEL

AS 400 CHANNEL

1 5/8" x 1" x 12 Ga.

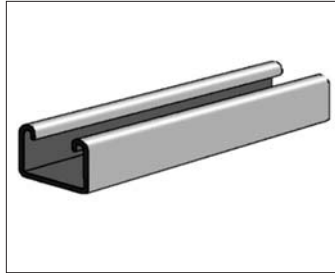

Discount Code A			Per 100 Ft.		
Part No.	Std. Pkg.	Wt.	PL	GR	PG
AS 400 10	500'	146	\$518.99	\$577.99	\$645.99
AS 400 20	500'	146	\$518.99	\$577.99	\$645.99

AS 400EH CHANNEL WITH SHORT SLOTS

1 1/8" x 9/16" Elongated Holes
On 2" Centers
1 5/8" x 1" x 12 Ga.

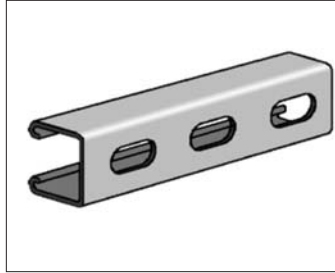

Discount Code A			Per 100 Ft.		
Part No.	Std. Pkg.	Wt.	PL	GR	PG
AS 400EH 10	500'	141	\$665.98	\$720.98	\$732.98
AS 400EH 20	500'	141	\$665.98	\$720.98	\$732.98

AS 400KO CHANNEL WITH KNOCK OUTS

7/8" Knock Outs On 6" Centers
1 5/8" x 1" x 12 Ga.

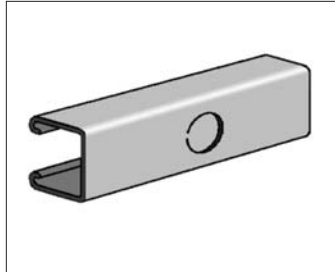

Discount Code A			Per 100 Ft.		
Part No.	Std. Pkg.	Wt.	PL	GR	PG
AS 400KO 10	500'	146	\$782.98	\$867.98	\$890.98
AS 400KO 20	500'	146	\$782.98	\$867.98	\$890.98

AS 400H CHANNEL WITH HOLES

9/16" Holes On 1 7/8" Centers
1 5/8" x 1" x 12 Ga.

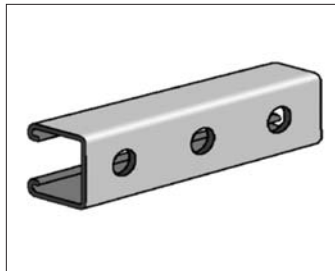

Discount Code A			Per 100 Ft.		
Part No.	Std. Pkg.	Wt.	PL	GR	PG
AS 400H 10	500'	141	\$773.98	\$865.98	\$880.98
AS 400H 20	500'	141	\$773.98	\$865.98	\$880.98

AS 400S CHANNEL WITH LONG SLOTS

1 3/32" x 3" Slots On 4" Centers
1 5/8" x 1" x 12 Ga.

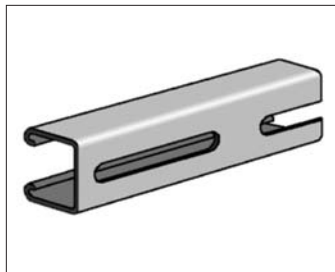

Discount Code A			Per 100 Ft.		
Part No.	Std. Pkg.	Wt.	PL	GR	PG
AS 400S 10	500'	141	\$746.98	\$783.98	\$797.98
AS 400S 20	500'	141	\$746.98	\$783.98	\$797.98

AS 400BTB WELDED CHANNEL

Two Pcs. AS 400 Welded Back To Back
1 5/8" x 2" x 12 Ga.

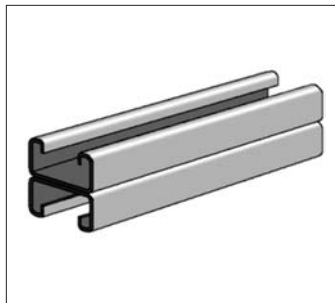

Discount Code A			Per 100 Ft.		
Part No.	Std. Pkg.	Wt.	PL	GR	PG
AS 400BTB 10	250'	292	\$1,485.97	\$1,653.96	\$1,686.96
AS 400BTB 20	300'	292	\$1,485.97	\$1,653.96	\$1,686.96

LEGEND:
GR: Painted Green
EG: Electro-Galvanized

PG: Pre-Galvanized
AL: Aluminum
HG: Hot Dipped Galvanized

PL: Plain
SS: Stainless Steel
ZD: Zinc Dichromate

SECTION 1 – CHANNEL

AS 500 CHANNEL

1 5/8" x 1 3/16" x 14 Ga.

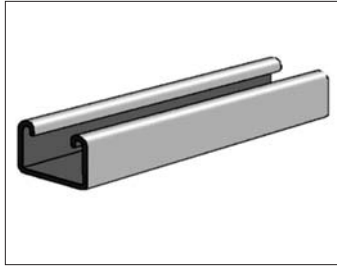

Discount Code A			Per 100 Ft.		
Part No.	Std. Pkg.	Wt.	PL	GR	PG
AS 500 10	500'	97	\$413.99	\$453.99	\$463.99
AS 500 20	500'	97	\$413.99	\$453.99	\$463.99

AS 500EH CHANNEL WITH ELONGATED HOLES

1 1/8" x 9/16" Elongated Holes
 On 2" Centers
 1 5/8" x 1 3/16" x 14 Ga.

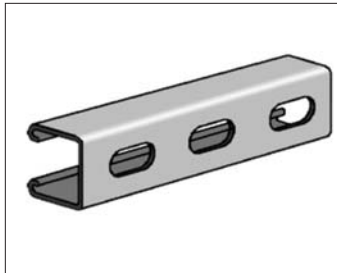

Discount Code A			Per 100 Ft.		
Part No.	Std. Pkg.	Wt.	PL	GR	PG
AS 500EH 10	500'	87	\$509.99	\$525.99	\$533.99
AS 500EH 20	500'	87	\$509.99	\$525.99	\$533.99

AS 500H CHANNEL WITH HOLES

9/16" Holes On 1 7/8" Centers
 1 5/8" x 1 3/16" x 14 Ga.

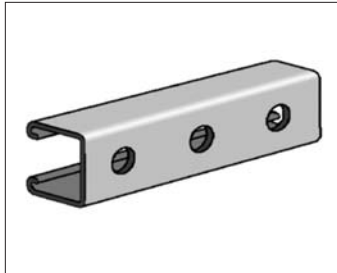

Discount Code A			Per 100 Ft.		
Part No.	Std. Pkg.	Wt.	PL	GR	PG
AS 500H 10	500'	87	\$537.99	\$558.99	\$563.99
AS 500H 20	500'	87	\$537.99	\$558.99	\$563.99

AS 500S CHANNEL WITH LONG SLOTS

1 3/32" x 3" Slots On 4" Centers
 1 5/8" x 1 3/16" x 14 Ga.

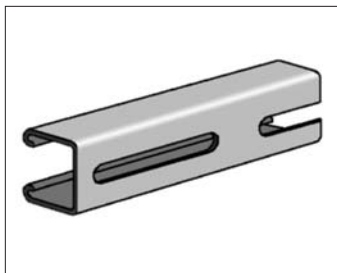

Discount Code A			Per 100 Ft.		
Part No.	Std. Pkg.	Wt.	PL	GR	PG
AS 500S 10	500'	87	\$537.99	\$552.99	\$561.99
AS 500S 20	500'	87	\$537.99	\$552.99	\$561.99

AS 500BTB WELDED CHANNEL

Two Pcs. AS 500 Welded Back To Back
 1 5/8" x 1 5/8" x 14 Ga.

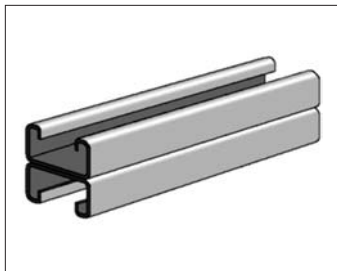

Discount Code A			Per 100 Ft.		
Part No.	Std. Pkg.	Wt.	PL	GR	PG
AS 500BTB 10	250'	194	\$1,136.97	\$1,183.97	\$1,288.97
AS 500BTB 20	300'	194	\$1,136.97	\$1,183.97	\$1,288.97

SECTION 1 – CHANNEL

AS 520 CHANNEL

1⁵/₈" x 1³/₁₆" x 12 Ga.

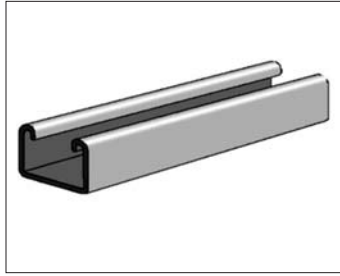

Discount Code A			Per 100 Ft.		
Part No.	Std. Pkg.	Wt.	PL	GR	PG
AS 520 10	500'	128	\$569.99	\$607.99	\$617.99
AS 520 20	500'	128	\$569.99	\$607.99	\$617.99

AS 520EH CHANNEL WITH ELONGATED HOLES

1¹/₈" x 9/₁₆" Elongated Holes
On 2" Centers
1⁵/₈" x 1³/₁₆" x 12 Ga.

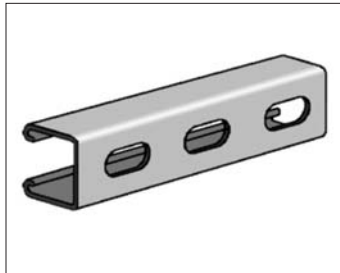

Discount Code A			Per 100 Ft.		
Part No.	Std. Pkg.	Wt.	PL	GR	PG
AS 520EH 10	500'	123	\$680.98	\$699.98	\$706.98
AS 520EH 20	500'	123	\$680.98	\$699.98	\$706.98

AS 520S CHANNEL WITH LONG SLOTS

1³/₃₂" x 3" Slots On 4" Centers
1⁵/₈" x 1³/₁₆" x 12 Ga.

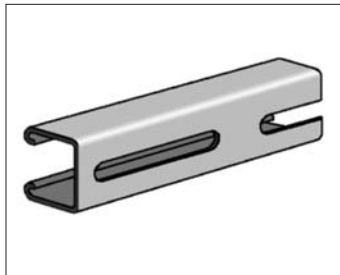

Discount Code A			Per 100 Ft.		
Part No.	Std. Pkg.	Wt.	PL	GR	PG
AS 520S 10	500'	118	\$710.98	\$712.98	\$738.98
AS 520S 20	500'	118	\$710.98	\$712.98	\$738.98

AS 520H CHANNEL WITH HOLES

9/₁₆" Holes On 1⁷/₈" Centers
1⁵/₈" x 1³/₁₆" x 12 Ga.

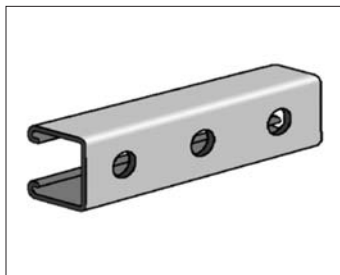

Discount Code A			Per 100 Ft.		
Part No.	Std. Pkg.	Wt.	PL	GR	PG
AS 520H 10	500'	123	\$710.98	\$736.98	\$739.98
AS 520H 20	500'	123	\$710.98	\$736.98	\$739.98

AS 520BTB WELDED CHANNEL

Two Pcs. AS 520 Welded Back To Back
1⁵/₈" x 1⁵/₈" x 12 Ga.

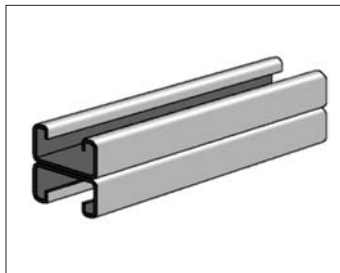

Discount Code A			Per 100 Ft.		
Part No.	Std. Pkg.	Wt.	PL	GR	PG
AS 520BTB 10	250'	256	\$1,354.97	\$1,366.97	\$1,401.97
AS 520BTB 20	300'	256	\$1,354.97	\$1,366.97	\$1,401.97

LEGEND:
GR: Painted Green
EG: Electro-Galvanized

PG: Pre-Galvanized
AL: Aluminum
HG: Hot Dipped Galvanized

PL: Plain
SS: Stainless Steel
ZD: Zinc Dichromate

SECTION 1 – CHANNEL

AS 707 RACEWAY CLOSURE STRIP

For All 1⁵/₈" Width Channels
(10' Length)

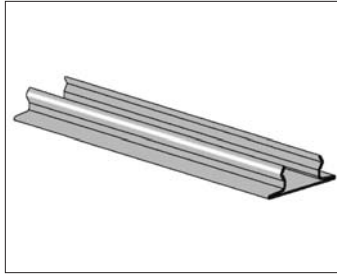

Discount Code A			Per 100 Ft.	
Part No.	Std. Pkg.	Wt.	GR	PG
AS 707 10	1,000'	47	\$324.99	\$324.99

AS 707P PAINTED CLOSURE STRIP

For All 1⁵/₈" Width Channels
(10' Length)

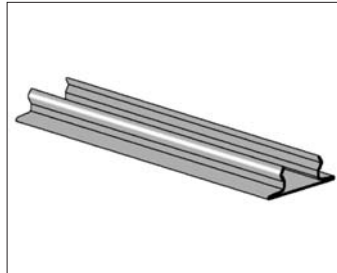

Discount Code A			Per 100 Ft.		
Part No.	Std. Pkg.	Wt.	GR	GREY	WHITE
AS 707P 10	1,000'	10	\$357.99	\$357.99	\$357.99

SECTION 2 – CHANNEL NUTS & HARDWARE

DATA: The selection table shows the correct locking nuts for each size channel.

Long Spring

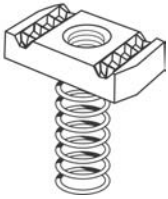

Cat. No.	Size	Thd.	Thk.	Wt./100 Pc.	Channel
AS LS	1/4"	20	1/4"	7	AS 100, AS 150
AS LS	3/8"	16	3/8"	10	
AS LS	1/2"	13	3/8"	10	
AS LS	1/2"	13	1/2"	13	
AS LS	5/8"	11	7/16"	23	
AS LS	3/4"	10	7/16"	20	
AS LS	5/16"	18	3/8"	7	

Without Spring

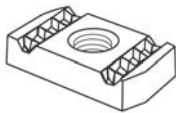

Cat. No.	Size	Thd.	Thk.	Wt./100 Pc.	Channel
AS NS	1/4"	20	1/4"	6	All Anvil-Strut™
AS NS	3/8"	16	3/8"	9	
AS NS	1/2"	13	3/8"	9	
AS NS	1/2"	13	1/2"	12	AS 100, AS 150, AS 200, AS 210, AS 300
AS NS	5/8"	11	7/16"	20	
AS NS	3/4"	10	7/16"	18	
AS NS	7/8"	9	7/16"	16	
AS NS	5/8"	11	3/8"	14	All Anvil-Strut™
AS NS	3/4"	10	3/8"	14	
AS NS	5/16"	18	3/8"	7	

Regular Spring

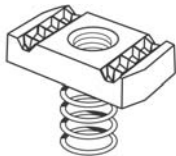

Cat. No.	Size	Thd.	Thk.	Wt./100 Pc.	Channel
AS RS	1/4"	20	1/4"	7	AS 200, AS 210, AS 300
AS RS	3/8"	16	3/8"	10	
AS RS	1/2"	13	3/8"	10	
AS RS	1/2"	13	1/2"	13	
AS RS	5/8"	11	7/16"	23	
AS RS	3/4"	10	7/16"	20	
AS RS	5/16"	18	3/8"	7	
AS RS	7/8"	9	7/16"	17	

Short Spring

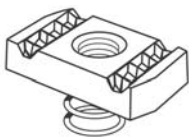

Cat. No.	Size	Thd.	Thk.	Wt./100 Pc.	Channel
AS SS	1/4"	20	1/4"	7	AS 400, AS 500
AS SS	3/8"	16	3/8"	9	
AS SS	1/2"	13	3/8"	9	
AS SS	5/8"	11	3/8"	10	
AS SS	3/4"	10	3/8"	9	
AS SS	5/16"	18	3/8"	7	

Top Grip

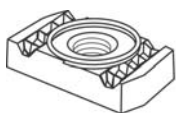

Cat. No.	Size	Thd.	Thk.	Wt./100 Pc.	Channel
AS TG	1/4"	20	1/4"	6	All Anvil-Strut™
AS TG	3/8"	16	3/8"	9	
AS TG	1/2"	13	3/8"	9	
AS TG	5/16"	18	3/8"	7	

SPECIFICATIONS

GENERAL

Anvil-Strut™ Grip Lock Nuts are designed with specially formed teeth in the parallel channel recesses to grip the returned lip of the channel. The shearing action of the teeth assures positive locking of the Anvil-Strut™ channels to the fittings.

MATERIAL

Anvil-Strut™ Grip Lock Nuts are manufactured from mild steel bars, and are case hardened to a depth of .003" to .005" after machining, conforming to ASTM A576 GR1015. Selected sizes also available in Stainless Steel.

FINISH

All Anvil-Strut™ Grip Lock Nuts and Hardware have an electro-galvanized finish (ASTM-B-633 BSCI), unless otherwise noted.

ORDERING

On the Anvil-Strut™ Grip Lock Nuts, consult the selection table which shows the correct locking nut for each size channel. On the Hardware please specify the diameter or size required, and length where applicable.

LOAD DATA

Resistance to Slip	Pull Out Strength
12 Gauge - 1,400#	12 Gauge - 2,000#
14 Gauge - 1,100#	14 Gauge - 1,140#
15 Gauge - 1,100#	15 Gauge - 1,100#

NOTES

1. Test performed with 1/2" - 13 Bolt tightened to 50/Ft./Lbs. torque.
2. Tests performed in accordance with "The Metal Framing Manufacturers Association" 1983 Specifications.
3. Safety Factor of 3.

LEGEND:
GR: Painted Green
EG: Electro-Galvanized

PG: Pre-Galvanized
AL: Aluminum
HG: Hot Dipped Galvanized

PL: Plain
SS: Stainless Steel
ZD: Zinc Dichromate



NUTS/HARDWARE

SECTION 2 – CHANNEL NUTS & HARDWARE

AS LS CLAMPING NUT WITH LONG SPRING

Use With AS 100 and AS 150 Channel.



Discount Code C		Per 100 Pieces		
Part No.	Size	Std. Pkg.	Wt.	EG
AS LS	1/4" x 20	50	7.5	\$269.99
AS LS	3/8" x 16	50	10.2	\$272.99
AS LS	1/2" x 13	50	12.3	\$288.99
AS LS	5/8" x 11	50	15.8	\$482.99
AS LS	3/4" x 10	50	14.1	\$543.99

This item sold only in full box quantities.

AS NS CLAMPING NUT WITHOUT SPRING

Use With All 1 5/8" Wide Channel.

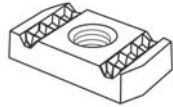

Discount Code C		Per 100 Pieces		
Part No.	Size	Std. Pkg.	Wt.	EG
AS NS	#10 x 24	100	6.7	\$186.00
AS NS	1/4" x 20	100	6.6	\$164.00
AS NS	5/16" x 18	100	6.4	\$183.00
AS NS	3/8" x 16	100	9.3	\$152.00
AS NS	1/2" x 13	100	11.4	\$168.00
AS NS	5/8" x 11	100	15.2	\$316.99
AS NS	3/4" x 10	100	13.0	\$368.99
AS NS	7/8" x 10	100	14.0	\$375.99
AS NS S	1/2" x 13	100	6.9	\$196.00
AS NS S	5/8" x 11	100	9.7	\$380.99
AS NS S	3/4" x 10	100	8.4	\$425.99

This item sold only in full box quantities.

AS RS CLAMPING NUT WITH REGULAR SPRING

Use With AS 200, AS 210 and AS 300 Channel.

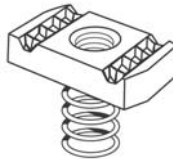

Discount Code C		Per 100 Pieces		
Part No.	Size	Std. Pkg.	Wt.	EG
AS RS	#8 x 32	100	7.2	\$257.99
AS RS	#10 x 24	100	7.2	\$231.99
AS RS	#10 x 32	100	7.2	\$244.99
AS RS	1/4" x 20	100	7.1	\$168.00
AS RS	5/16" x 18	100	7.0	\$216.99
AS RS	3/8" x 16	100	9.9	\$180.00
AS RS	1/2" x 13	100	11.9	\$200.00
AS RS	5/8" x 11	100	15.5	\$402.99
AS RS	3/4" x 10	100	13.8	\$462.99
AS RS	7/8" x 9	100	14.3	\$484.99

This item sold only in full box quantities.

AS SS CLAMPING NUT WITH SHORT SPRING

Use With AS 400 and AS 500 Channel.

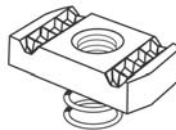

Discount Code C		Per 100 Pieces		
Part No.	Size	Std. Pkg.	Wt.	EG
AS SS	#8 x 32	100	7.0	\$216.00
AS SS	#10 x 24	100	7.0	\$216.00
AS SS	#10 x 32	100	7.0	\$591.99
AS SS	1/4" x 20	100	6.9	\$175.00
AS SS	5/16" x 18	100	6.7	\$205.00
AS SS	3/8" x 16	100	9.6	\$187.00
AS SS	1/2" x 13	100	8.8	\$204.00
AS SS	5/8" x 11	100	11.5	\$408.99

This item sold only in full box quantities.

SECTION 2 – CHANNEL NUTS & HARDWARE

AS TG TOP GRIP NUT WITH SPRING ON TOP

Use With All 1⁵/₈" Channel.

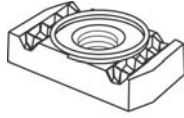

Discount Code C		Per 100 Pieces		
Part No.	Size	Std. Pkg.	Wt.	EG
ASTG	1/4" x 20	100	7.0	\$231.99
ASTG	3/8" x 16	100	10.0	\$240.99
ASTG	1/2" x 13	100	8.0	\$253.99

This item sold only in full box quantities.

AS 517 STUD NUT WITH RS SPRING

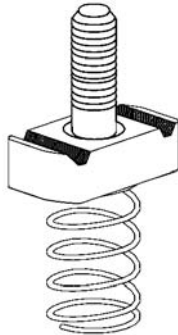

Discount Code C		Per 100 Pieces		
Part No.	Size	Std. Pkg.	Wt.	EG
AS 517	1/4" x 1"	100	8.1	\$831.98
AS 517	1/4" x 1 1/4"	100	8.3	\$935.98
AS 517	1/4" x 1 1/2"	100	8.6	\$945.98
AS 517	1/4" x 2"	100	9.1	\$951.98
AS 517	3/8" x 1"	100	13.0	\$1,043.98
AS 517	3/8" x 1 1/4"	100	14.0	\$1,059.98
AS 517	3/8" x 1 1/2"	100	14.0	\$1,225.97
AS 517	3/8" x 2"	100	15.0	\$1,253.97
AS 517	1/2" x 1"	100	15.0	\$1,276.97
AS 517	1/2" x 1 1/4"	100	16.0	\$1,351.97
AS 517	1/2" x 1 1/2"	100	17.0	\$1,363.97
AS 517	1/2" x 2"	100	19.0	\$1,369.97

AS 3281 DOUBLE CONVEYOR ADJUSTING NUT

Use For All 1⁵/₈" Wide Anvil-Strut™ Channels.

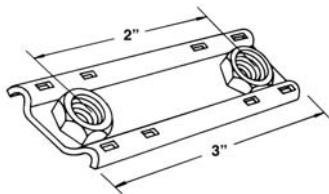

Discount Code C		Per 100 Pieces		
Part No.	Size	Threads	Wt.	EG
AS 3281	3/8"	16	17.5	\$455.99

This item sold only in full box quantities.

AS 83 HEXAGON NUT

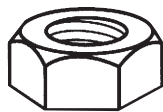

Discount Code D		Per 100 Pieces		
Part No.	Size	Std. Pkg.	Wt.	EG
AS 83	1/4"	500	0.7	\$28.00
AS 83	3/8"	500	1.6	\$36.00
AS 83	1/2"	100	3.8	\$64.00
AS 83	5/8"	50	7.3	\$91.00
AS 83	3/4"	50	11.9	\$157.00

FIG. 135 ROD COUPLING



Part No.
Fig. 135

For Prices, See Anvil International Pipe Hanger List Price Sheet.

FIG. 146 CONTINUOUS THREADED ROD



Part No.
Fig. 146

For Prices, See Anvil International Pipe Hanger List Price Sheet.

LEGEND:
 GR: Painted Green
 EG: Electro-Galvanized

PG: Pre-Galvanized
 AL: Aluminum
 HG: Hot Dipped Galvanized

PL: Plain
 SS: Stainless Steel
 ZD: Zinc Dichromate



NUTS/HARDWARE

SECTION 2 – CHANNEL NUTS & HARDWARE

**AS 203
 LINKED EYELET
 WITH STUD**



Discount Code D		Per 100 Pieces			
Part No.	Size	Max. Load	Std. Pkg.	Wt.	EG
AS 203	3/8"	610	100	27.0	\$2,217.95
AS 203	1/2"	610	50	45.0	\$2,411.94

**AS 209
 FLAT WASHER**



Discount Code D		Per 100 Pieces			
Part No.	Size	Std. Pkg.	Wt.	EG	
AS 209	1/4"	200	0.7	\$14.00	
AS 209	3/8"	100	1.5	\$23.00	
AS 209	1/2"	100	3.9	\$41.00	
AS 209	5/8"	100	7.7	\$87.00	
AS 209	3/4"	100	11.0	\$146.00	

This item sold only in full box quantities.

**AS 211
 LOCK WASHER**



Discount Code D		Per 100 Pieces			
Part No.	Size	Std. Pkg.	Wt.	EG	
AS 211	1/4"	100	0.3	\$21.00	
AS 211	3/8"	100	0.7	\$22.00	
AS 211	1/2"	100	1.5	\$34.00	

**AS 230
 FENDER WASHER**



Discount Code D		Per 100 Pieces			
Part No.	Size	Std. Pkg.	Wt.	EG	
AS 230	1/4"	100	3.3	\$84.00	
AS 230	3/8"	100	3.0	\$86.00	
AS 230	1/2"	100	2.8	\$112.00	

**AS 6075
 SLOTTED
 HEX HEAD
 MACHINE SCREW**

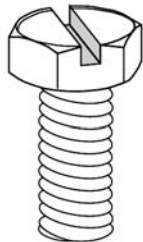

Discount Code D		Per 100 Pieces			
Part No.	Size	Std. Pkg.	Wt.	EG	
AS 6075	1/4" x 3/4"	100	1.7	\$43.00	
AS 6075	5/16" x 1"	100	2.6	\$58.00	
AS 6075	5/16" x 1 1/4"	100	3.0	\$106.00	
AS 6075	5/16" x 1 1/2"	100	3.4	\$63.00	
AS 6075	3/8" x 1 1/4"	100	5.3	\$111.00	

**AS 6108
 SQUARE NUT**



Discount Code D		Per 100 Pieces			
Part No.	Size	Std. Pkg.	Wt.	EG	
AS 6108	1/4"	100	0.9	\$17.00	
AS 6108	5/16"	100	1.6	\$34.00	
AS 6108	3/8"	100	2.6	\$50.00	
AS 6108	1/2"	100	5.8	\$80.00	

SECTION 2 – CHANNEL NUTS & HARDWARE

**AS 3500
SEISMIC
ROD STIFFENER**

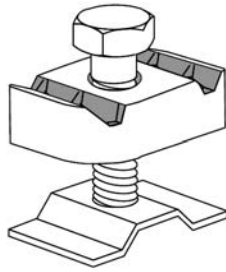

Discount Code C		Per 100 Pieces		
Part No.	Size	Std. Pkg.	Wt.	EG
AS 3500	3/8" - 5/8"	25	16.0	\$895.98

This item sold only in full box quantities.

**AS 6024
HEX HEAD
CAP SCREW**

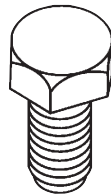

Discount Code D		Per 100 Pieces		
Part No.	Size	Std. Pkg.	Wt.	EG
AS 6024	1/4" x 3/4"	100	1.5	\$60.00
AS 6024	1/4" x 1"	100	1.8	\$60.00
AS 6024	1/4" x 1 1/4"	100	2.1	\$66.00
AS 6024	1/4" x 1 1/2"	100	2.4	\$71.00
AS 6024	3/8" x 3/4"	100	3.6	\$60.00
AS 6024	3/8" x 1"	100	4.2	\$62.00
AS 6024	3/8" x 1 1/4"	100	4.9	\$70.00
AS 6024	3/8" x 1 1/2"	100	5.6	\$90.00
AS 6024	3/8" x 2"	100	7.2	\$97.00
AS 6024	1/2" x 3/4"	100	8.1	\$91.00
AS 6024	1/2" x 1"	100	9.2	\$95.00
AS 6024	1/2" x 1 1/4"	100	10.4	\$110.00
AS 6024	1/2" x 1 1/2"	100	11.6	\$140.00
AS 6024	1/2" x 1 3/4"	100	13.0	\$260.99
AS 6024	1/2" x 2"	100	14.4	\$180.00

This item sold only in full box quantities.

NUTS/HARDWARE

LEGEND:
GR: Painted Green
EG: Electro-Galvanized

PG: Pre-Galvanized
AL: Aluminum
HG: Hot Dipped Galvanized

PL: Plain
SS: Stainless Steel
ZD: Zinc Dichromate

SECTION 3 – FITTINGS AND ACCESSORIES

**AS 85
 ROD OR
 INSULATOR
 SUPPORT**

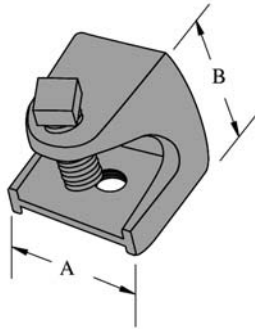

Discount Code D		Per 100 Pieces					
Part No.	Rod Size	A	B	Load Rating	Std. Pkg.	Wt.	EG
AS 85	1/4"	1 1/8"	1 1/4"	150	50	23	\$518.99
AS 85	3/8"	2"	2"	350	25	95	\$1,321.97
AS 85	1/2"	2 5/8"	2 1/2"	400	25	195	\$2,131.95

This item sold only in full box quantities.

FITTINGS

**FIG. 86
 CLAMP WITH
 LOCK NUT**

Size Range 3/8" thru 3/4".



Part No.	
Fig. 86	For Prices, See Anvil International Pipe Hanger List Price Sheet.

**FIG. 93
 TOP BEAM
 "C" CLAMP**

Size Range 3/8" thru 1/2".



Part No.	
Fig. 93	For Prices, See Anvil International Pipe Hanger List Price Sheet.

**FIG. 94
 TOP BEAM
 "C" CLAMP**

Size Range 5/8" thru 3/4".



Part No.	
Fig. 94	For Prices, See Anvil International Pipe Hanger List Price Sheet.

**FIG. 95
 CLAMP WITH
 LOCK NUT**

Size Range 3/8" thru 3/4".



Part No.	
Fig. 95	For Prices, See Anvil International Pipe Hanger List Price Sheet.

SECTION 3 – FITTINGS AND ACCESSORIES

**AS 135X
BEAM CLAMP
LIGHT DUTY**

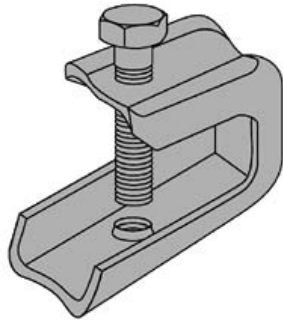

Discount Code D		Per 100 Pieces			
Part No.	Size	Load Rating	Std. Pkg.	Wt.	EG
AS 135X	1/4"	75	50	14.0	\$393.99

**AS 601
TWO HOLE
SPLICE PLATE**

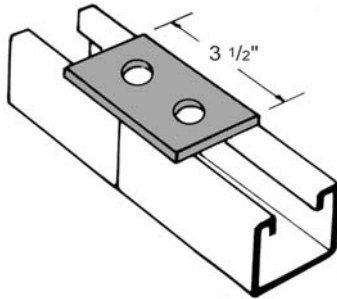

Discount Code D		Per 100 Pieces		
Part No.	Std. Pkg.	Wt.	GR	EG
AS 601	50	38	\$289.99	\$289.99

This item sold only in full box quantities.
For Load Rating, see page 74.

**AS 602
THREE HOLE
SPLICE PLATE**

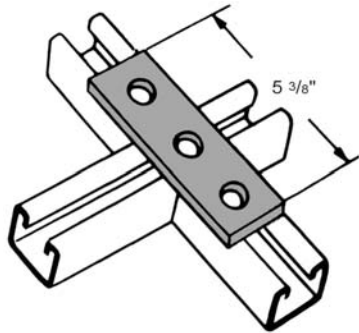

Discount Code D		Per 100 Pieces		
Part No.	Std. Pkg.	Wt.	GR	EG
AS 602	25	50	\$434.99	\$434.99

**AS 603
TWO HOLE
END ANGLE**

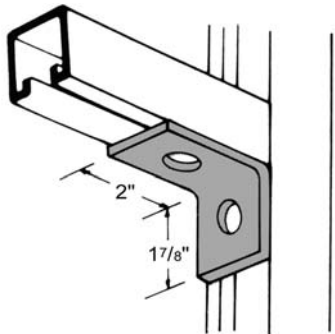

Discount Code D		Per 100 Pieces		
Part No.	Std. Pkg.	Wt.	GR	EG
AS 603	50	38	\$267.99	\$267.99

This item sold only in full box quantities.
For Load Rating, see page 74.

**AS 604
TWO HOLE
CORNER ANGLE**

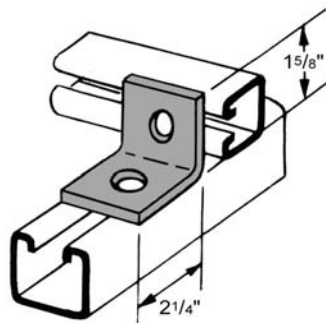

Discount Code D		Per 100 Pieces		
Part No.	Std. Pkg.	Wt.	GR	EG
AS 604	50	38	\$284.99	\$284.99

This item sold only in full box quantities.
For Load Rating, see page 74.

FITTINGS

LEGEND:
 GR: Painted Green
 EG: Electro-Galvanized

PG: Pre-Galvanized
 AL: Aluminum
 HG: Hot Dipped Galvanized

PL: Plain
 SS: Stainless Steel
 ZD: Zinc Dichromate

SECTION 3 – FITTINGS AND ACCESSORIES

**AS 605
 THREE HOLE
 CORNER ANGLE**

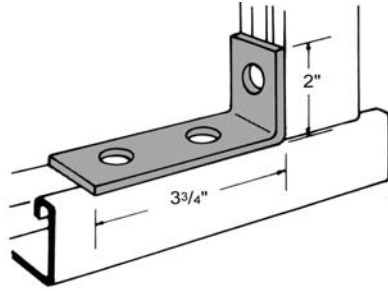

Discount Code D			Per 100 Pieces	
Part No.	Std. Pkg.	Wt.	GR	EG
AS 605	50	58	\$390.99	\$390.99

This item sold only in full box quantities.
 For Load Rating, see page 74.

**AS 606
 THREE HOLE
 CORNER ANGLE**

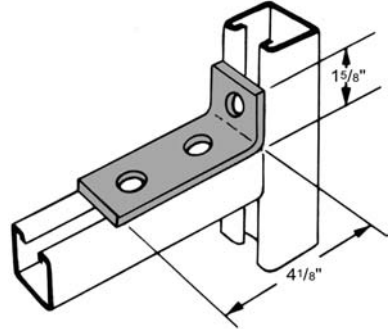

Discount Code D			Per 100 Pieces	
Part No.	Std. Pkg.	Wt.	GR	EG
AS 606	50	58	\$391.99	\$391.99

For Load Rating, see page 74.

**AS 607
 FOUR HOLE
 CORNER ANGLE**

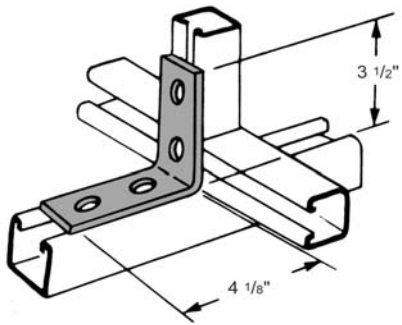

Discount Code D			Per 100 Pieces	
Part No.	Std. Pkg.	Wt.	GR	EG
AS 607	25	78	\$524.99	\$524.99

This item sold only in full box quantities.
 For Load Rating, see page 74.

**AS 609
 TWO HOLE OFFSET
 "Z" SUPPORT**

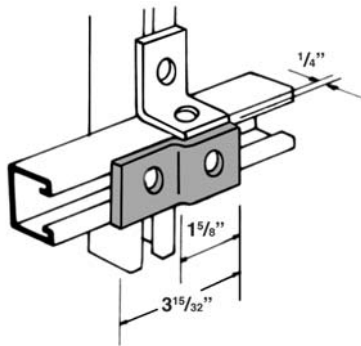

Discount Code D			Per 100 Pieces	
Part No.	Std. Pkg.	Wt.	GR	EG
AS 609	25	38	\$531.99	\$531.99

**AS 611
 "Z" SUPPORT**

Use With AS 200, AS 210,
 and AS 500BTB.

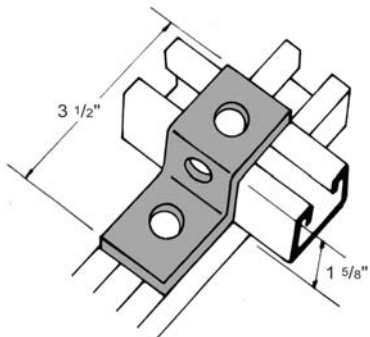

Discount Code D			Per 100 Pieces	
Part No.	Std. Pkg.	Wt.	GR	EG
AS 611	50	55	\$538.99	\$538.99

SECTION 3 – FITTINGS AND ACCESSORIES

AS 612 "Z" SUPPORT

Use With AS 400.

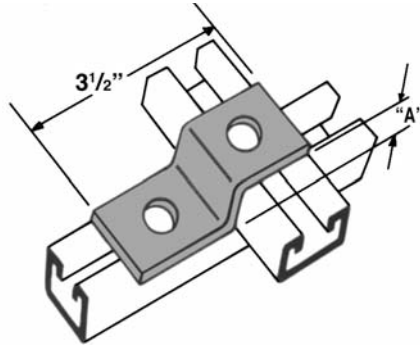

Discount Code D			Per 100 Pieces		
Part No.	A	Std. Pkg.	Wt.	GR	EG
AS 612	1"	50	47	\$852.98	\$852.98

AS 613 "U" SUPPORT

Use With AS 200, AS 210,
and AS 500BTB.

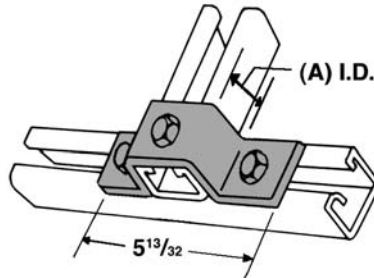

Discount Code D			Per 100 Pieces		
Part No.	A	Std. Pkg.	Wt.	GR	EG
AS 613	1 5/8"	25	88	\$652.98	\$652.98

AS 614 FOUR HOLE JOINT ANGLE CONNECTOR

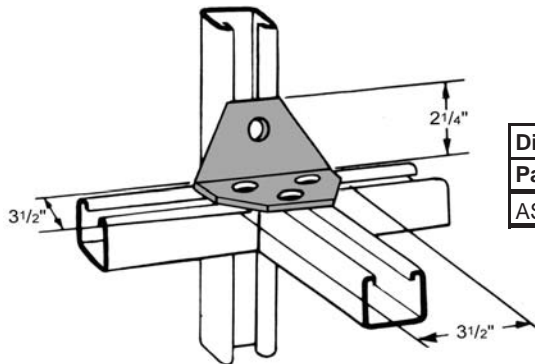

Discount Code D			Per 100 Pieces		
Part No.	Std. Pkg.	Wt.	GR	EG	
AS 614	25	103	\$1,955.95	\$1,955.95	

AS 615 FIVE HOLE SHELF JOINT ANGLE CONNECTOR

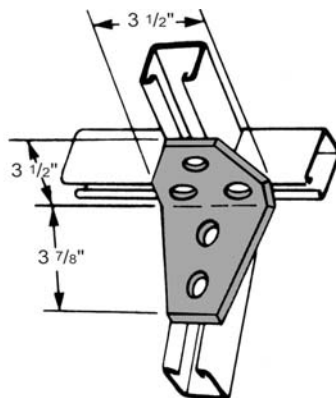

Discount Code D			Per 100 Pieces		
Part No.	Std. Pkg.	Wt.	GR	EG	
AS 615	10	135	\$2,092.95	\$2,092.95	

AS 616 FOUR HOLE SPLICE CLEVIS

Use With AS 200 and
AS 210.

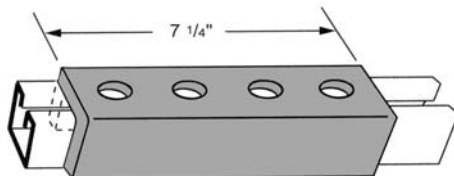

Discount Code D			Per 100 Pieces		
Part No.	Std. Pkg.	Wt.	GR	EG	
AS 616	10	265	\$2,000.95	\$2,000.95	

This item sold only in full box quantities.

FITTINGS

LEGEND:
 GR: Painted Green
 EG: Electro-Galvanized

PG: Pre-Galvanized
 AL: Aluminum
 HG: Hot Dipped Galvanized

PL: Plain
 SS: Stainless Steel
 ZD: Zinc Dichromate



SECTION 3 – FITTINGS AND ACCESSORIES

FITTINGS

**AS 617
 THREE HOLE
 SWIVEL PLATE**

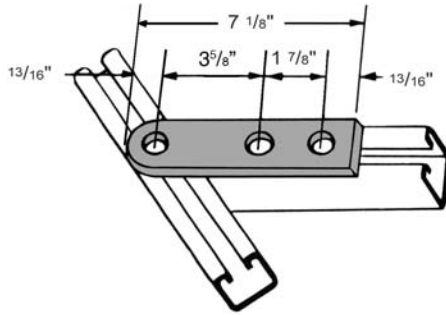

Discount Code D			Per 100 Pieces	
Part No.	Std. Pkg.	Wt.	GR	EG
AS 617	25	75	\$1,336.97	\$1,336.97

**AS 619
 SQUARE
 WASHER**

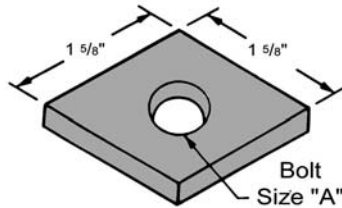

Discount Code D			Per 100 Pieces		
Part No.	A	Std. Pkg.	Wt.	GR	EG
AS 619	1/4"	100	18	\$159.00	\$159.00
AS 619	3/8"	100	18	\$139.00	\$139.00
AS 619	1/2"	100	17	\$139.00	\$139.00
AS 619	5/8"	100	16	\$177.00	\$177.00
AS 619	3/4"	100	15	\$243.99	\$243.99

This item sold only in full box quantities.

**AS 620
 TWO HOLE
 CONNECTING
 PLATE**

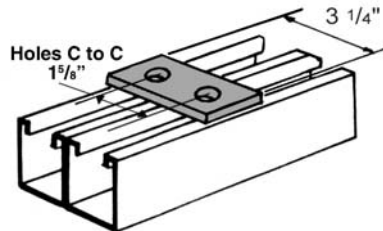

Discount Code D			Per 100 Pieces	
Part No.	Std. Pkg.	Wt.	GR	EG
AS 620	50	35	\$342.99	\$342.99

**AS 624
 TWO HOLE
 CLOSED ANGLE
 CONNECTOR**

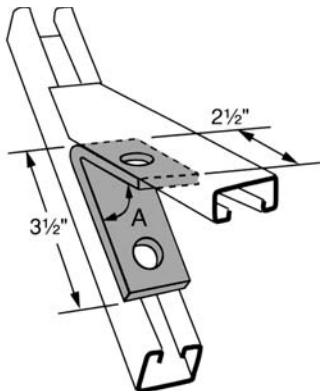

Discount Code D			Per 100 Pieces		
Part No.	Angle A	Std. Pkg.	Wt.	GR	EG
AS 624	37 1/2°	25	58	\$733.98	\$733.98
AS 624	45°	25	58	\$595.99	\$595.99
AS 624	52 1/2°	25	58	\$733.98	\$733.98
AS 624	60°	25	58	\$733.98	\$733.98
AS 624	67 1/2°	25	58	\$733.98	\$733.98
AS 624	75°	25	58	\$733.98	\$733.98
AS 624	82 1/2°	25	58	\$733.98	\$733.98

**AS 629
 THREE HOLE
 SPLICE CLEVIS**

Use With AS 200, AS 210.

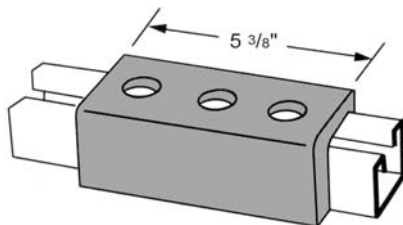

Discount Code D			Per 100 Pieces	
Part No.	Std. Pkg.	Wt.	GR	EG
AS 629	20	197	\$1,819.96	\$1,819.96

SECTION 3 – FITTINGS AND ACCESSORIES

AS 631 TWO HOLE SPLICE CLEVIS

Use With AS 200,
AS 210.

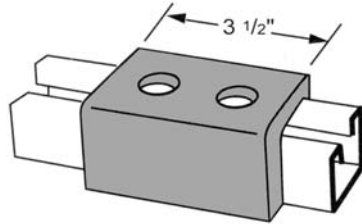

Discount Code D			Per 100 Pieces	
Part No.	Std. Pkg.	Wt.	GR	EG
AS 631	25	128	\$1,348.97	\$1,348.97

AS 633 TWO HOLE OPEN ANGLE CONNECTOR

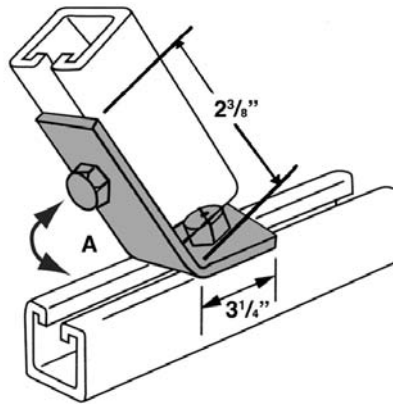

Discount Code D			Per 100 Pieces		
Part No.	Angle A	Std. Pkg.	Wt.	GR	EG
AS 633	82½°	25	58	\$720.98	\$720.98
AS 633	75°	25	58	\$720.98	\$720.98
AS 633	67½°	25	58	\$720.98	\$720.98
AS 633	60°	25	58	\$720.98	\$720.98
AS 633	52½°	25	58	\$720.98	\$720.98
AS 633	45°	25	58	\$537.99	\$537.99
AS 633	37½°	25	58	\$720.98	\$720.98
AS 633	30°	25	58	\$720.98	\$720.98
AS 633	22½°	25	58	\$720.98	\$720.98
AS 633	15°	25	58	\$720.98	\$720.98
AS 633	7½°	25	58	\$720.98	\$720.98

This item sold only in full box quantities.

AS 644 TWO HOLE SPLICE CLEVIS

Use With AS 500,
AS 520.

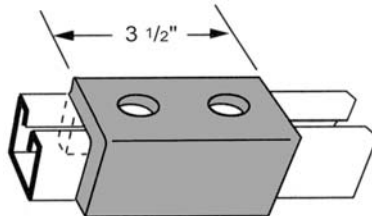

Discount Code D			Per 100 Pieces	
Part No.	Std. Pkg.	Wt.	GR	EG
AS 644	20	85	\$992.98	\$992.98

AS 645 THREE HOLE SPLICE CLEVIS

Use With AS 500,
AS 520.

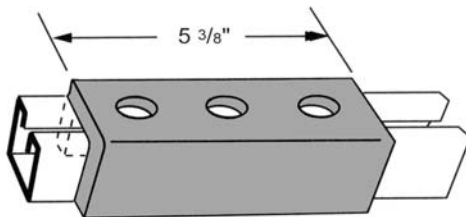

Discount Code D			Per 100 Pieces	
Part No.	Std. Pkg.	Wt.	GR	EG
AS 645	10	130	\$1,402.97	\$1,402.97

AS 646 FOUR HOLE SPLICE CLEVIS

Use With AS 500.

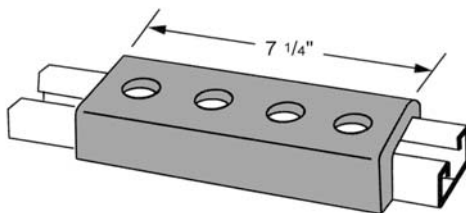

Discount Code D			Per 100 Pieces	
Part No.	Std. Pkg.	Wt.	GR	EG
AS 646	10	176	\$1,736.96	\$1,736.96

FITTINGS

LEGEND:
GR: Painted Green
EG: Electro-Galvanized

PG: Pre-Galvanized
AL: Aluminum
HG: Hot Dipped Galvanized

PL: Plain
SS: Stainless Steel
ZD: Zinc Dichromate



SECTION 3 – FITTINGS AND ACCESSORIES

AS 651 REVERSIBLE STRUT BRACKET

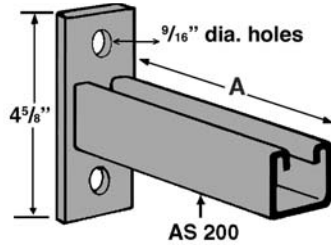

Part No.	A	*Uniform Load	Std. Pkg.	Per 100 Pieces	
				Wt.	GR EG
AS 651	6"	1200	Bulk	185	\$2,856.93 \$2,856.93
AS 651	12"	600	Bulk	293	\$3,273.92 \$3,273.92
AS 651	18"	400	Bulk	401	\$3,630.92 \$3,630.92
AS 651	24"	300	Bulk	509	\$4,787.89 \$4,787.89

This item sold only in full box quantities.
 * Mounted On 12 Ga. Channel.

AS 655, AS 656 TYPE "A" END CAP

Use With AS 200 Channel.
 Use With AS 300 Channel and AS 349 Insert.

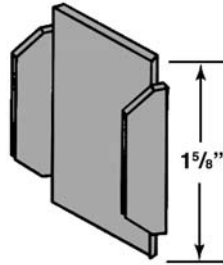

Part No.	Std. Pkg.	Per 100 Pieces	
		Wt.	PG
AS 655	100	11	\$108.00
AS 656	100	15	\$112.00

AS656 sold only in full box quantities.

AS 661 T1 STRUT BRACKET (SLOT UP)

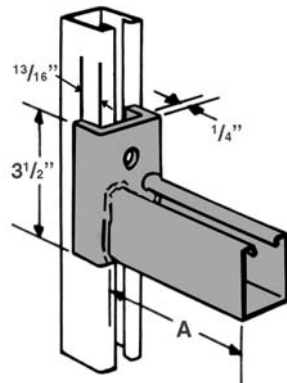

Part No.	A	*Uniform Load	Std. Pkg.	Per 100 Pieces	
				Wt.	GR
AS 661 T1	6"	1600	Bulk	191	\$2,818.93
AS 661 T1	12"	800	Bulk	292	\$3,483.92
AS 661 T1	18"	600	Bulk	436	\$4,341.90
AS 661 T1	24"	450	Bulk	536	\$5,209.88

* Mounted On 12 Ga. Channel.

AS 661 T2 STRUT BRACKET (SLOT DOWN)

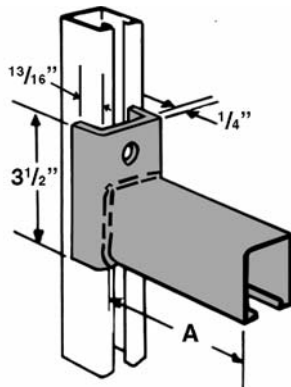

Part No.	A	*Uniform Load	Std. Pkg.	Per 100 Pieces	
				Wt.	GR
AS 661 T2	6"	1600	Bulk	191	\$2,818.93
AS 661 T2	12"	800	Bulk	292	\$3,483.92
AS 661 T2	18"	600	Bulk	436	\$4,340.90
AS 661 T2	24"	450	Bulk	536	\$5,209.88

* Mounted On 12 Ga. Channel.

AS 665 FOUR HOLE DOUBLE CORNER CONNECTOR

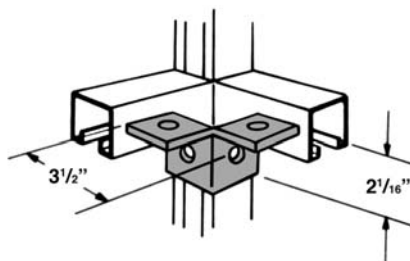

Part No.	Std. Pkg.	Per 100 Pieces		
		Wt.	GR	EG
AS 665	25	76	\$1,176.97	\$1,176.97

FITTINGS

SECTION 3 – FITTINGS AND ACCESSORIES

**AS 666
SIX HOLE
DOUBLE
CORNER
CONNECTOR**

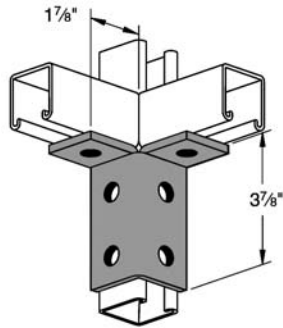

Discount Code D			Per 100 Pieces	
Part No.	Std. Pkg.	Wt.	GR	EG
AS 666	25	115	\$1,528.96	\$1,528.96

**AS 667
EIGHT HOLE
DOUBLE
CORNER
CONNECTOR**

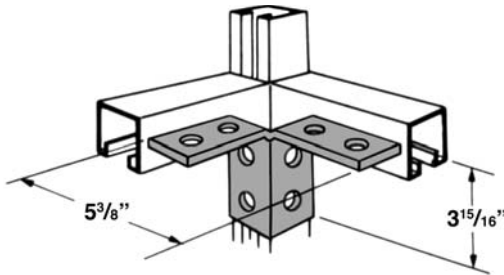

Discount Code D			Per 100 Pieces	
Part No.	Std. Pkg.	Wt.	GR	EG
AS 667	10	155	\$2,157.95	\$2,157.95

**AS 668
SIX HOLE
THREE ANGLE
CONNECTOR**

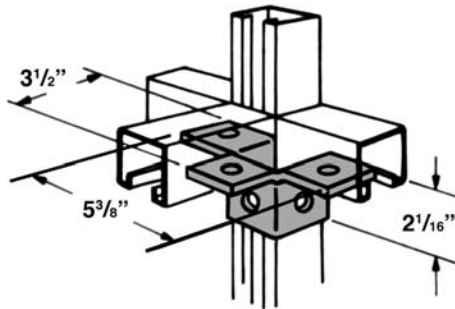

Discount Code D			Per 100 Pieces	
Part No.	Std. Pkg.	Wt.	GR	EG
AS 668	10	113	\$1,886.96	\$1,886.96

**AS 669
TWELVE
HOLE
THREE ANGLE
CLEVIS
CONNECTOR**

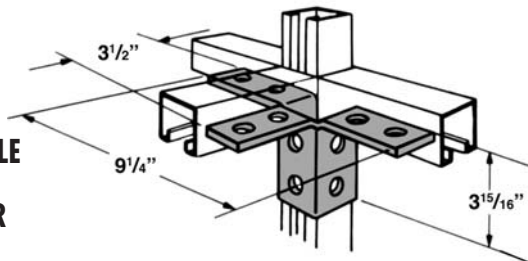

Discount Code D			Per 100 Pieces	
Part No.	Std. Pkg.	Wt.	GR	EG
AS 669	10	230	\$3,349.92	\$3,349.92

**AS 677
CUP SUPPORT
FOR STANDARD
SINGLE STRUT**

Use With AS 200 and AS 210.

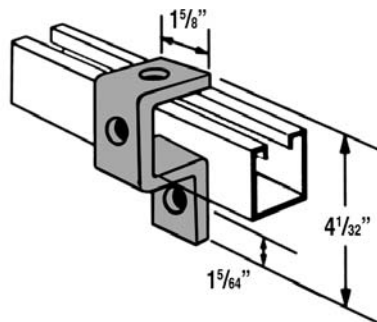

Discount Code D			Per 100 Pieces	
Part No.	Std. Pkg.	Wt.	GR	EG
AS 677	25	76	\$1,040.98	\$1,040.98

FITTINGS

LEGEND:
GR: Painted Green
EG: Electro-Galvanized

PG: Pre-Galvanized
AL: Aluminum
HG: Hot Dipped Galvanized

PL: Plain
SS: Stainless Steel
ZD: Zinc Dichromate



SECTION 3 – FITTINGS AND ACCESSORIES

FITTINGS

AS 678 THREE HOLE "U" SUPPORT

Use With AS 150 BTB.

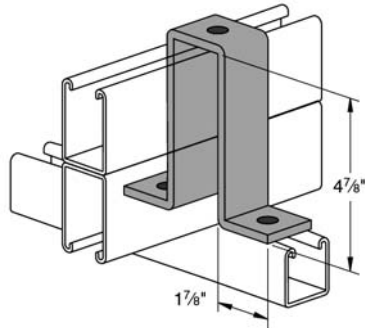

Discount Code D			Per 100 Pieces	
Part No.	Std. Pkg.	Wt.	GR	EG
AS 678	10	197	\$2,300.95	\$2,300.95

AS 679 "U" SUPPORT

Use For AS 100,
AS 200BTB, AS 210BTB.

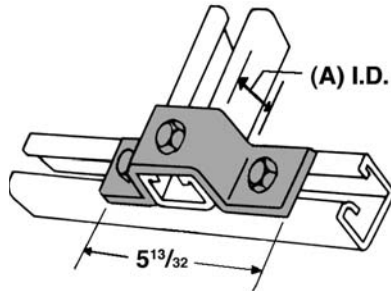

Discount Code D			Per 100 Pieces		
Part No.	A	Std. Pkg.	Wt.	GR	EG
AS 679	3 1/4"	25	128	\$1,568.96	\$1,568.96

AS 684 BEAM CLAMP

Includes Cup Point
Set Screw.

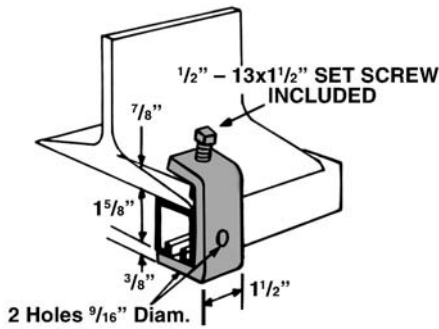

Discount Code D			Per 100 Pieces		
Part No.	Load Rating	Std. Pkg.	Wt.	GR	EG
AS 684	500	25	94	\$1,455.97	\$1,455.97

AS 685 BEAM CLAMP

Includes Cup Point Set Screw.

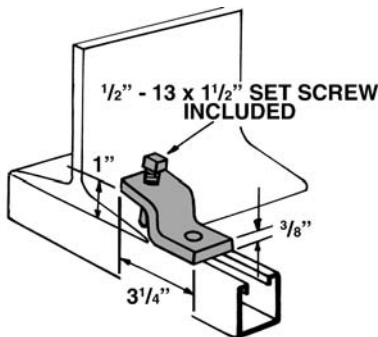

Discount Code D			Per 100 Pieces		
Part No.	Load Rating	Std. Pkg.	Wt.	GR	EG
AS 685	450	20	63	\$1,426.97	\$1,426.97

AS 686 BEAM CLAMP

Order AS 6024 1/2" x
1 1/2" Separately.

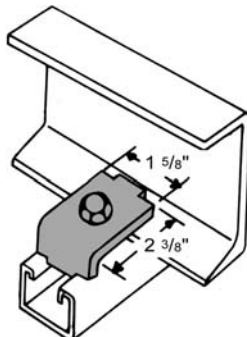

Discount Code D			Per 100 Pieces		
Part No.	*Load Rating	Std. Pkg.	Wt.	GR	EG
AS 686	600	50	26	\$398.99	\$398.99

This item sold only in full box quantities.
 * Load Rating When Used with 12 Ga. Channel.
 14 Ga. Channel is 500 lbs.

SECTION 3 – FITTINGS AND ACCESSORIES

AS 687 SLOTTED "U" SUPPORT

Use With AS 200 and AS 210.

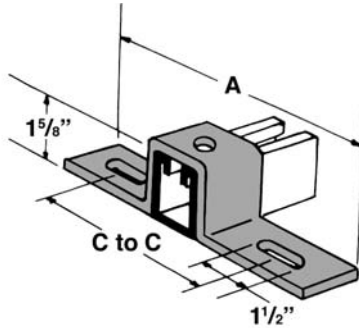

Discount Code D				Per 100 Pieces		
Part No.	A	C to C	Std. Pkg.	Wt.	GR	EG
AS 687 A	7 1/4"	4 1/8"	10	105	\$1,633.96	\$1,633.96
AS 687 B	8 1/2"	5 3/8"	10	120	\$1,828.96	\$1,828.96
AS 687 C	10 3/8"	7 1/4"	25	130	\$1,973.95	\$1,973.95

AS 689 ADJUSTABLE DOUBLE SLOTTED CORNER CONNECTOR

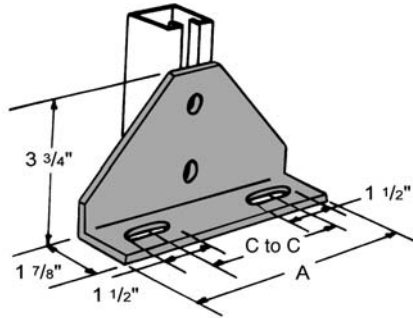

Discount Code D				Per 100 Pieces		
Part No.	A	C to C	Std. Pkg.	Wt.	GR	EG
AS 689 A	6 5/8"	4"	10	190	\$1,954.95	\$1,954.95
AS 689 B	8 5/8"	6"	10	242	\$2,922.93	\$2,922.93

AS 708 SINGLE CHANNEL BRACKET SUPPORT

Use With AS 200,
AS 210 and AS 500 BTB.

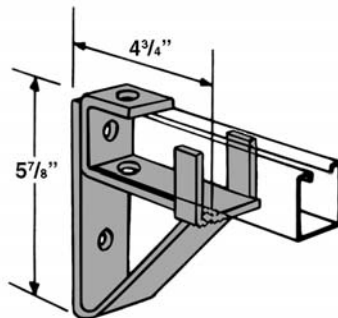

Discount Code D		Per 100 Pieces			
Part No.	Std. Pkg.	Wt.	GR	EG	
AS 708	20	235	\$5,170.88	\$5,170.88	

AS 710 "U" SUPPORT

Use With AS 300.

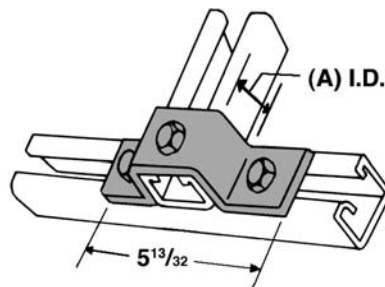

Discount Code D		Per 100 Pieces			
Part No.	A	Std. Pkg.	Wt.	GR	EG
AS 710	1 3/8"	25	84	\$1,242.97	\$1,242.97

AS 711 "Z" SUPPORT

Use With AS 300.

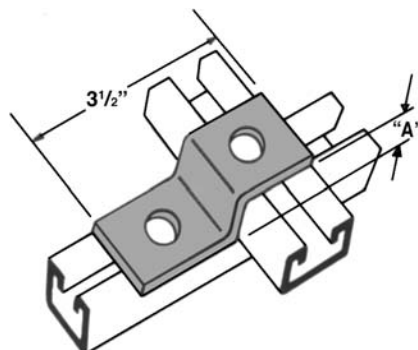

Discount Code D		Per 100 Pieces			
Part No.	A	Std. Pkg.	Wt.	GR	EG
AS 711	1 3/8"	25	53	\$953.98	\$953.98

FITTINGS

LEGEND:
GR: Painted Green
EG: Electro-Galvanized

PG: Pre-Galvanized
AL: Aluminum
HG: Hot Dipped Galvanized

PL: Plain
SS: Stainless Steel
ZD: Zinc Dichromate



SECTION 3 – FITTINGS AND ACCESSORIES

FITTINGS

**AS 712
CROSS PLATE**

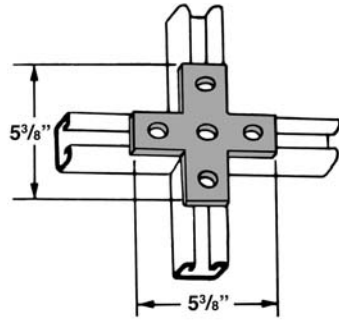

Discount Code D			Per 100 Pieces	
Part No.	Std. Pkg.	Wt.	GR	EG
AS 712	10	105	\$1,620.96	\$1,620.96

**AS 714
"T" PLATE**

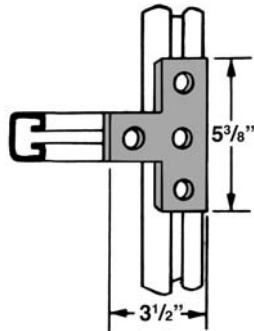

Discount Code D			Per 100 Pieces	
Part No.	Std. Pkg.	Wt.	GR	EG
AS 714	25	80	\$895.98	\$895.98

This item sold only in full box quantities.

**AS 715
"T" PLATE
90° ANGLE**

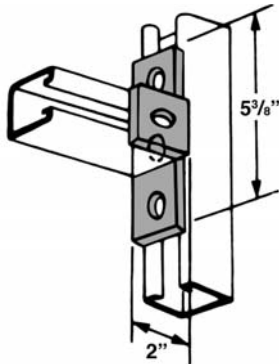

Discount Code D			Per 100 Pieces	
Part No.	Std. Pkg.	Wt.	GR	EG
AS 715	20	71	\$1,260.97	\$1,260.97

**AS 718
FLAT
ANGLE PLATE**

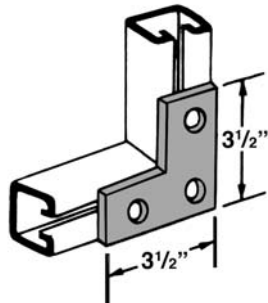

Discount Code D			Per 100 Pieces	
Part No.	Std. Pkg.	Wt.	GR	EG
AS 718	50	58	\$602.99	\$602.99

This item sold only in full box quantities.

**AS 719
FOUR HOLE
CORNER PLATE**

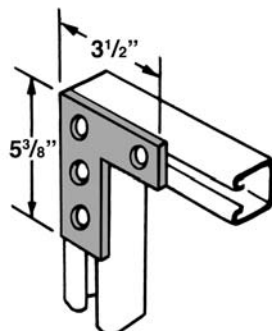

Discount Code D			Per 100 Pieces	
Part No.	Std. Pkg.	Wt.	GR	EG
AS 719	20	80	\$1,124.97	\$1,124.97

SECTION 3 – FITTINGS AND ACCESSORIES

**AS 720
RH & LH
ANGLE PLATE
CONNECTOR**

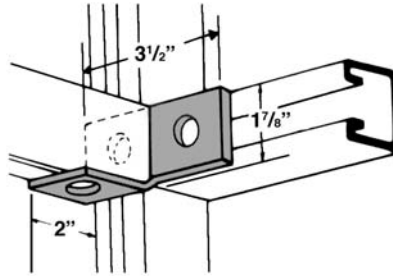

Discount Code D			Per 100 Pieces	
Part No.	Std. Pkg.	Wt.	GR	EG
AS 720 RH	25	55	\$1,127.97	\$1,127.97
AS 720 LH	25	55	\$1,127.97	\$1,127.97

When Ordering, Specify RH or LH.

**AS 721
"U" SUPPORT**

Use With AS 100, AS 200BTB,
and AS 210BTB.

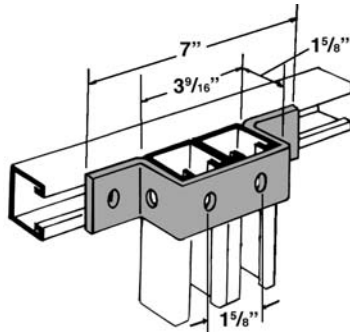

Discount Code D			Per 100 Pieces	
Part No.	Std. Pkg.	Wt.	GR	EG
AS 721	25	105	\$2,106.95	\$2,106.95

**AS 732
SHELF
BRACKET**

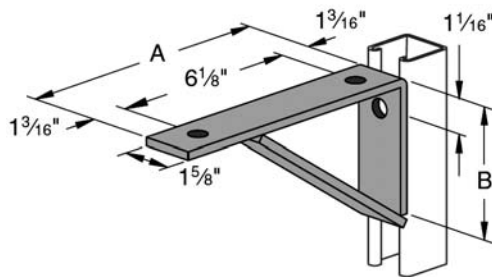

Discount Code D			Per 100 Pieces			
Part No.	A	B	*Uniform Load	Std. Pkg.	Wt.	GR
AS 732	8"	6"	800	Bulk	168	\$3,222.93
AS 732	10"	6"	800	Bulk	202	\$3,439.92
AS 732	12"	6"	900	Bulk	258	\$3,618.92
AS 732	14"	6"	900	Bulk	292	\$6,035.86
AS 732	16"	6"	1200	Bulk	381	\$8,502.80
AS 732	18"	6"	1200	Bulk	416	\$8,914.79
AS 732	20"	6"	1000	Bulk	461	\$9,326.78

* Mounted On 12 Ga. Channel.

**AS 733
SIX HOLE
"U" SUPPORT**

Use With AS 200
and AS 210.

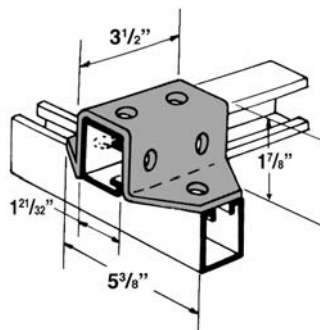

Discount Code D			Per 100 Pieces	
Part No.	Std. Pkg.	Wt.	GR	EG
AS 733	10	171	\$3,209.93	\$3,209.93

**AS 735
EIGHT HOLE
"U" SUPPORT**

Use With AS 200 BTB.

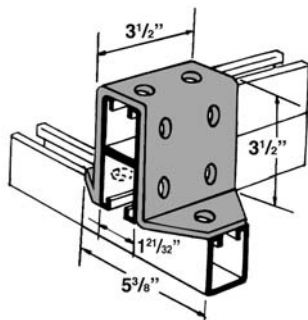

Discount Code D			Per 100 Pieces	
Part No.	Std. Pkg.	Wt.	GR	EG
AS 735	10	257	\$3,680.91	\$3,680.91

LEGEND:
 GR: Painted Green
 EG: Electro-Galvanized

PG: Pre-Galvanized
 AL: Aluminum
 HG: Hot Dipped Galvanized

PL: Plain
 SS: Stainless Steel
 ZD: Zinc Dichromate

SECTION 3 – FITTINGS AND ACCESSORIES

**AS 744
 FLAT CORNER
 CONNECTOR**

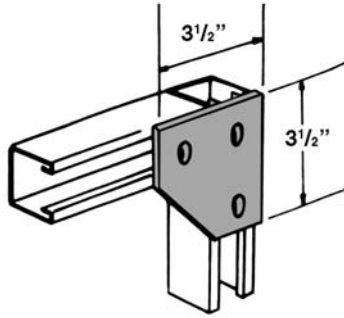

Discount Code D			Per 100 Pieces	
Part No.	Std. Pkg.	Wt.	GR	EG
AS 744	25	70	\$965.98	\$965.98

**AS 745
 THREE HOLE
 CORNER ANGLE**

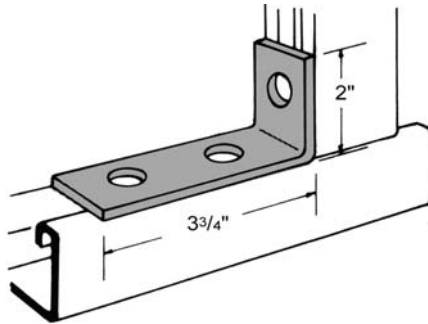

Discount Code D			Per 100 Pieces	
Part No.	Std. Pkg.	Wt.	GR	EG
AS 745	50	58	\$439.99	\$439.99

For Load Rating, see page 74.

**AS 747
 SYMMETRICAL
 FOUR HOLE
 CONNECTOR**

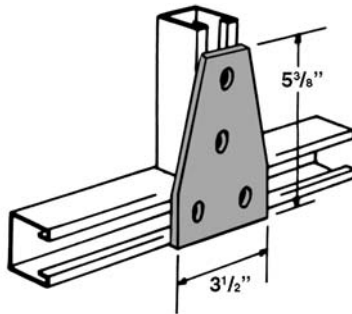

Discount Code D			Per 100 Pieces	
Part No.	Std. Pkg.	Wt.	GR	EG
AS 747	20	105	\$1,536.96	\$1,536.96

**AS 748
 FOUR HOLE
 CORNER JOINT
 CONNECTOR**

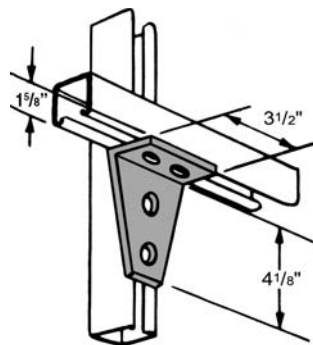

Discount Code D			Per 100 Pieces	
Part No.	Std. Pkg.	Wt.	GR	EG
AS 748	25	105	\$1,679.96	\$1,679.96

**AS 750
 FOUR HOLE
 CORNER
 CONNECTOR**

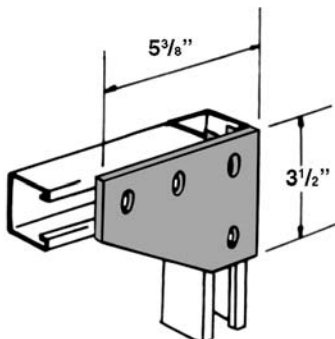

Discount Code D			Per 100 Pieces	
Part No.	Std. Pkg.	Wt.	GR	EG
AS 750	20	105	\$1,248.97	\$1,248.97

SECTION 3 – FITTINGS AND ACCESSORIES

**AS 763, AS 764
SLOTTED
ADJUSTMENT
CORNER ANGLE**

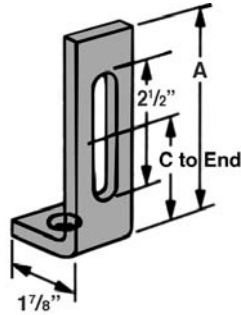

**AS 781
FOUR HOLE
OPEN ANGLE
CONNECTOR**

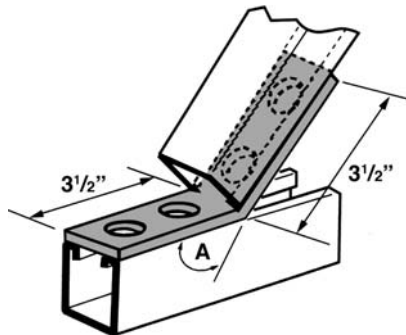

**AS 793
FOUR HOLE
CLOSED ANGLE
CONNECTOR**

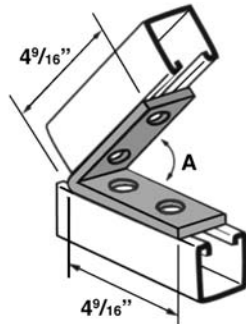

**AS 806
TWO HOLE
ANGLE WITH
IMPRESSIONS
ON BOTH LEGS**

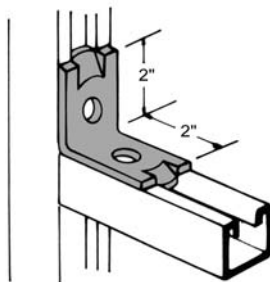

**AS 809
DOUBLE
CHANNEL
BRACKET**

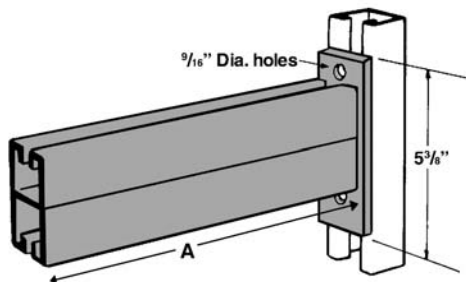

Discount Code D		Per 100 Pieces				
Part No.	A	C to End	Std. Pkg.	Wt.	GR	EG
AS 763	4 7/8"	2 1/2"	25	65	\$899.98	\$899.98
AS 764	6 7/8"	4 1/2"	25	65	\$1,207.97	\$1,207.97

Discount Code D		Per 100 Pieces				
Part No.	Angle A	Std. Pkg.	Wt.	GR	EG	
AS 781	7 1/2°	25	78	\$969.98	\$969.98	
AS 781	15°	25	78	\$969.98	\$969.98	
AS 781	22 1/2°	25	78	\$969.98	\$969.98	
AS 781	30°	25	78	\$969.98	\$969.98	
AS 781	37 1/2°	25	78	\$969.98	\$969.98	
AS 781	45°	25	78	\$951.98	\$951.98	
AS 781	52 1/2°	25	78	\$969.98	\$969.98	
AS 781	60°	25	78	\$969.98	\$969.98	
AS 781	67 1/2°	25	78	\$969.98	\$969.98	
AS 781	75°	25	78	\$969.98	\$969.98	
AS 781	82 1/2°	25	78	\$969.98	\$969.98	

Discount Code D		Per 100 Pieces				
Part No.	Angle A	Std. Pkg.	Wt.	GR	EG	
AS 793	37 1/2°	25	100	\$1,589.96	\$1,589.96	
AS 793	45°	25	100	\$1,302.97	\$1,302.97	
AS 793	52 1/2°	25	100	\$1,589.96	\$1,589.96	
AS 793	60°	25	100	\$1,589.96	\$1,589.96	
AS 793	67 1/2°	25	100	\$1,589.96	\$1,589.96	
AS 793	75°	25	100	\$1,589.96	\$1,589.96	
AS 793	82 1/2°	25	100	\$1,589.96	\$1,589.96	

Discount Code D		Per 100 Pieces			
Part No.	Std. Pkg.	Wt.	GR	EG	
AS 806	50	40	\$408.99	\$408.99	

Discount Code D		Per 100 Pieces				
Part No.	A	*Uniform Load	Std. Pkg.	Wt.	GR	EG
AS 809	12"	2000	Bulk	502	\$6,640.85	\$6,640.85
AS 809	18"	1300	Bulk	692	\$7,897.82	\$7,897.82
AS 809	24"	1000	Bulk	882	\$9,286.79	\$9,286.79
AS 809	30"	800	Bulk	1,072	\$10,569.76	\$10,569.76
AS 809	36"	650	Bulk	1,262	\$12,284.72	\$12,284.72

* Mounted on 12 Ga. Channel.

FITTINGS

LEGEND:
GR: Painted Green
EG: Electro-Galvanized

PG: Pre-Galvanized
AL: Aluminum
HG: Hot Dipped Galvanized

PL: Plain
SS: Stainless Steel
ZD: Zinc Dichromate



SECTION 3 – FITTINGS AND ACCESSORIES

**AS 821
 EIGHT HOLE
 DOUBLE ANGLE
 CONNECTOR**

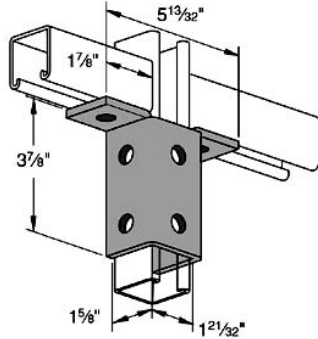

Discount Code D			Per 100 Pieces	
Part No.	Std. Pkg.	Wt.	GR	EG
AS 821	10	150	\$2,208.95	\$2,208.95

**AS 825 RH/LH
 PIPE AXLE
 SUPPORT**

Specify RH or LH (1 1/2" Max. Pipe).

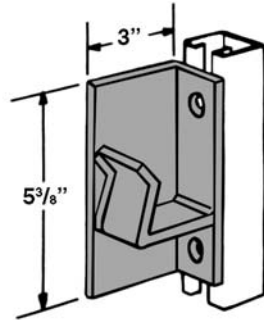

Discount Code D			Per 100 Pieces		
Part No.	*Load Rating	Std. Pkg.	Wt.	GR	EG
AS 825 RH	2500	10	220	\$3,014.93	\$3,014.93
AS 825 LH	2500	10	220	\$3,014.93	\$3,014.93

**AS 838 RH/LH 6" THRU 30"
 SHELF BRACKET**

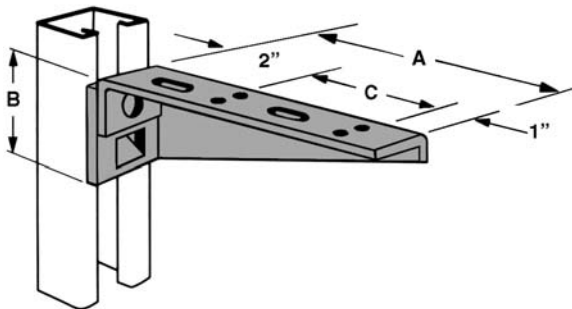

Discount Code D			Per 100 Pieces				
Part No.	A	B	C	Std. Pkg.	Wt.	GR	EG
AS 838 RH/LH	6"	2 15/16"	3"	25	58	\$1,233.97	\$1,233.97
AS 838 RH/LH	8"	2 15/16"	5"	25	83	\$1,368.97	\$1,368.97
AS 838 RH/LH	10"	2 15/16"	7"	25	114	\$1,440.97	\$1,440.97
AS 838 RH/LH	12"	3 7/16"	3"	25	149	\$1,928.96	\$1,928.96
AS 838 RH/LH	14"	3 15/16"	4"	25	174	\$2,317.95	\$2,317.95
AS 838 RH/LH	16"	4 7/16"	5"	20	225	\$2,613.94	\$2,613.94
AS 838 RH/LH	18"	4 15/16"	6"	20	255	\$3,195.93	\$3,195.93
AS 838 RH/LH	20"	5 7/16"	7"	20	295	\$3,831.91	\$3,831.91
AS 838 RH/LH	22"	5 15/16"	8"	Bulk	361	\$4,514.90	\$4,514.90
AS 838 RH/LH	24"	6 7/16"	5"	Bulk	396	\$4,820.89	\$4,820.89
AS 838 RH/LH	26"	6 15/16"	5 11/16"	Bulk	456	\$5,101.88	\$5,101.88
AS 838 RH/LH	28"	7 7/16"	6 5/16"	Bulk	479	\$5,419.87	\$5,419.87
AS 838 RH/LH	30"	7 15/16"	7"	Bulk	544	\$5,758.87	\$5,758.87

Uniform Load Rating 275 lbs. When Mounted on 12 Ga. Channel.

**AS 854
 FLAT
 CONNECTOR**

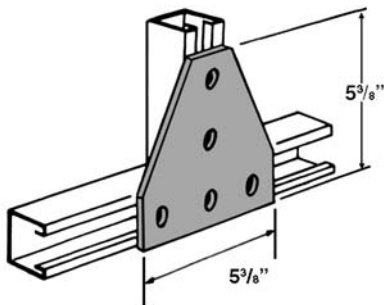

Discount Code D			Per 100 Pieces	
Part No.	Std. Pkg.	Wt.	GR	EG
AS 854	25	148	\$2,267.95	\$2,267.95

FITTINGS

SECTION 3 – FITTINGS AND ACCESSORIES

AS 855 ANGULAR "I" BEAM CLAMP

AS 855 1 — Use With AS 200,
AS 210.
AS 855 2 — Use With AS 500.

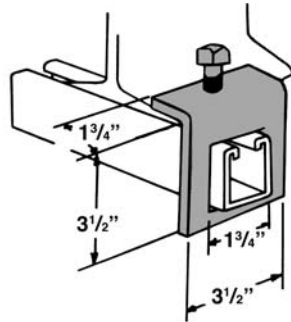

Discount Code D		Per 100 Pieces			
Part No.	Load Rating	Std. Pkg.	Wt.	GR	EG
AS 855 1	500	25	107	\$951.98	\$951.98
AS 855 2	500	25	98	\$1,153.97	\$1,153.97

This item sold only in full box quantities.

AS 858 HEAVY DUTY SUSPENSION ROD BEAM CLAMPS

Includes Set Screw.
(Safety Anchor Strap AS 871 To
Be Ordered Separately According
To Length Required.)

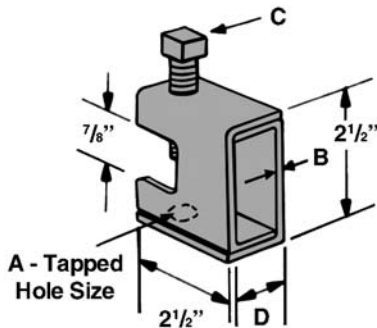

Discount Code D		Per 100 Pieces			
Part No.	A	Std. Pkg.	Wt.	EG	
AS 858	1/4" x 20	10	67	\$1,881.96	
AS 858	5/16" x 18	10	67	\$2,084.95	
AS 858	3/8" x 16	10	100	\$1,990.95	
AS 858	1/2" x 13	10	130	\$2,199.95	
AS 858	5/8" x 11	10	160	\$3,430.92	
AS 858	3/4" x 10	10	160	\$4,162.90	

B	C	D	Load Rating
1/8"	3/8" x 1 1/2"	7/8"	650
1/8"	3/8" x 1 1/2"	7/8"	650
3/16"	1/2" x 1 1/2"	1 5/16"	1100
1/4"	1/2" x 1 1/2"	1 5/16"	1600
5/16"	5/8" x 1 1/2"	1 15/16"	2400
5/16"	5/8" x 1 1/2"	1 15/16"	2400

AS 865 WIDE THROAT HEAVY DUTY BEAM CLAMP

Includes Set Screw.
(Safety Anchor Strap AS 871 To
Be Ordered Separately According
To Length Required.)

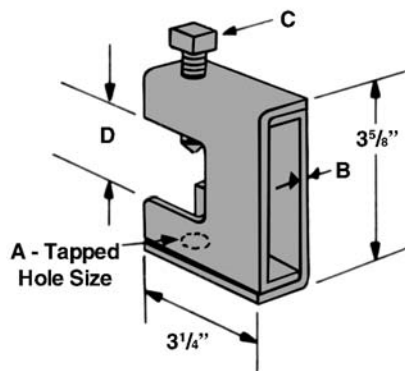

Discount Code D		Per 100 Pieces			
Part No.	A	Std. Pkg.	Wt.	EG	
AS 865	1/4" x 20	10	151	\$3,548.92	
AS 865	3/8" x 16	10	195	\$3,380.92	
AS 865	1/2" x 13	10	225	\$6,882.84	

B	C	D	Load Rating
3/16"	1/2" x 2"	1 11/16"	800
1/4"	1/2" x 2"	1 11/16"	1300
5/16"	5/8" x 2"	1 11/16"	1900

AS 871 SAFETY ANCHOR STRAP

(For Heavy Duty
Beam Clamps.)
Use with AS 858,
AS 865 (Cannot
Be Used With
5/8" Rod Size
Beam Clamps
and Larger).

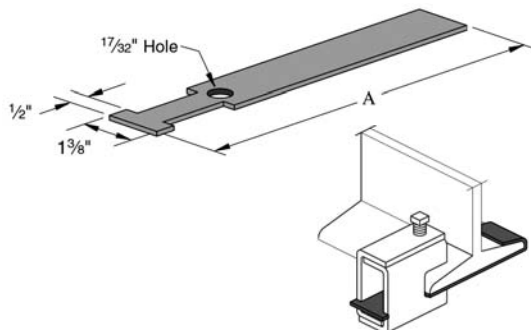

Discount Code D		Per 100 Pieces			
Part No.	A	Std. Pkg.	Wt.	EG	
AS 871	9"	Bulk	33	\$479.99	
AS 871	12"	Bulk	48	\$495.99	
AS 871	15"	Bulk	57	\$541.99	

FITTINGS

LEGEND:
GR: Painted Green
EG: Electro-Galvanized

PG: Pre-Galvanized
AL: Aluminum
HG: Hot Dipped Galvanized

PL: Plain
SS: Stainless Steel
ZD: Zinc Dichromate



SECTION 3 – FITTINGS AND ACCESSORIES

**AS 888
 FOUR HOLE
 SPLICE PLATE**

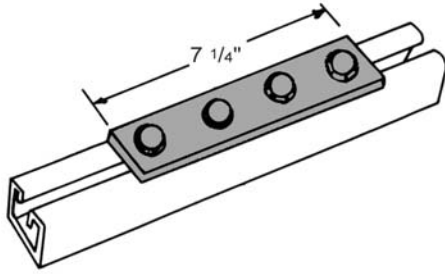

Discount Code D			Per 100 Pieces	
Part No.	Std. Pkg.	Wt.	GR	EG
AS 888	25	78	\$573.99	\$573.99

This item sold only in full box quantities.

**AS 901, AS 902
 TYPE "A" END CAP**

Use With AS 100, AS 400 Channel.

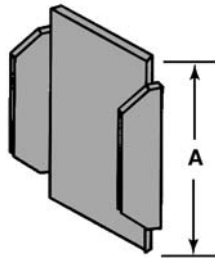

Discount Code D			Per 100 Pieces	
Part No.	A	Std. Pkg.	Wt.	PG
AS 901	1"	100	11	\$121.00
AS 902	3 1/4"	100	22	\$682.98

**AS 907
 "I" BEAM
 CLAMP**

Includes Cup Point Set Screw.

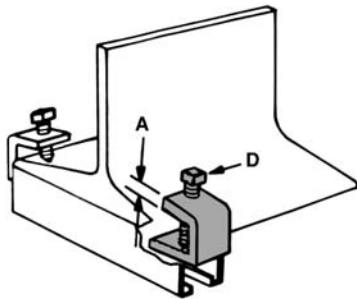

Discount Code D			Per 100 Pieces				
Part No.	A	D	Load Rating	Std. Pkg.	Wt.	GR	EG
AS 907	1/4"	3/8 x 16 x 1 1/2	500	50	26	\$1,091.97	\$1,091.97

**AS 913
 TEN HOLE
 TWO ANGLE
 CLEVIS
 CONNECTOR**

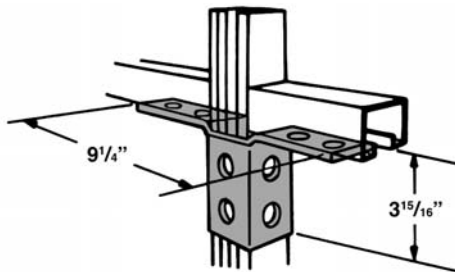

Discount Code D			Per 100 Pieces	
Part No.	Std. Pkg.	Wt.	GR	EG
AS 913	10	193	\$3,812.91	\$3,812.91

**AS 921
 ONE HOLE ANGLE**

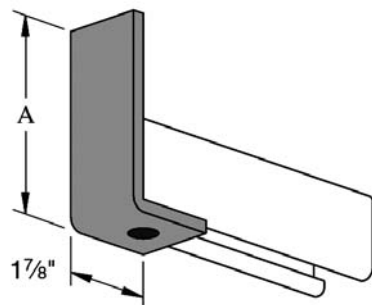

Discount Code D			Per 100 Pieces		
Part No.	A	Std. Pkg.	Wt.	GR	EG
AS 921 A	3 7/8"	25	61	\$736.98	\$736.98
AS 921 B	5 7/8"	25	84	\$916.98	\$916.98
AS 921 C	7 7/8"	25	107	\$1,134.97	\$1,134.97
AS 921 D	9 7/8"	25	130	\$1,336.97	\$1,336.97

SECTION 3 – FITTINGS AND ACCESSORIES

**AS 922 RH & LH
TWO HOLE
SINGLE CORNER
ANGLE CONNECTOR**

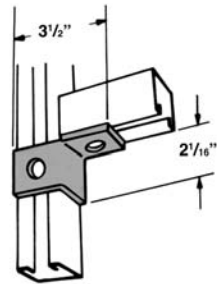

Discount Code D			Per 100 Pieces	
Part No.	Std. Pkg.	Wt.	GR	EG
AS 922 RH	20	60	\$1,458.97	\$1,458.97
AS 922 LH	20	60	\$1,458.97	\$1,458.97

When Ordering, Specify RH or LH.

**AS 923
FIVE HOLE
TWO ANGLE
CONNECTOR**

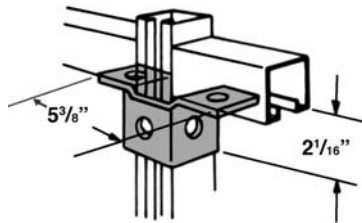

Discount Code D			Per 100 Pieces	
Part No.	Std. Pkg.	Wt.	GR	EG
AS 923	25	93	\$1,921.96	\$1,921.96

**AS 925
SYMMETRICAL
THREE HOLE
JOINT CONNECTOR**

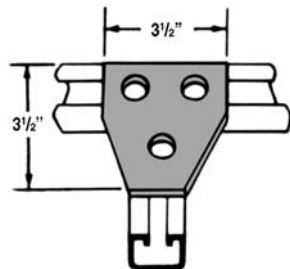

Discount Code D			Per 100 Pieces	
Part No.	Std. Pkg.	Wt.	GR	EG
AS 925	25	70	\$1,187.97	\$1,187.97

**AS 926
STRUT BRACE**

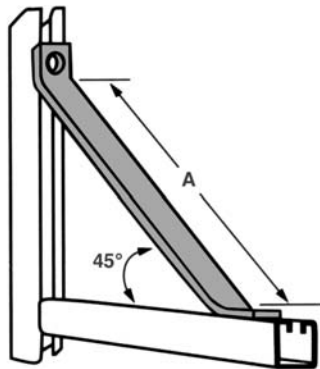

Discount Code D			Per 100 Pieces		
Part No.	A	Std. Pkg.	Wt.	GR	EG
AS 926	12"	15	160	\$1,591.96	\$1,591.96
AS 926	16 5/8"	Bulk	218	\$1,686.96	\$1,686.96
AS 926	24"	Bulk	280	\$2,167.95	\$2,167.95

**AS 927
FIVE HOLE
CORNER
CONNECTOR**

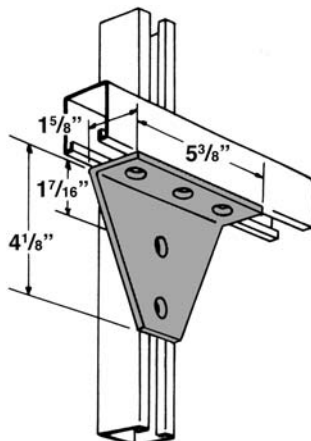

Discount Code D			Per 100 Pieces	
Part No.	Std. Pkg.	Wt.	GR	EG
AS 927	10	154	\$2,349.95	\$2,349.95

FITTINGS

LEGEND:
GR: Painted Green
EG: Electro-Galvanized

PG: Pre-Galvanized
AL: Aluminum
HG: Hot Dipped Galvanized

PL: Plain
SS: Stainless Steel
ZD: Zinc Dichromate



SECTION 3 – FITTINGS AND ACCESSORIES

FITTINGS

AS 928 "Z" SUPPORT

Use For AS 500
and AS 520.

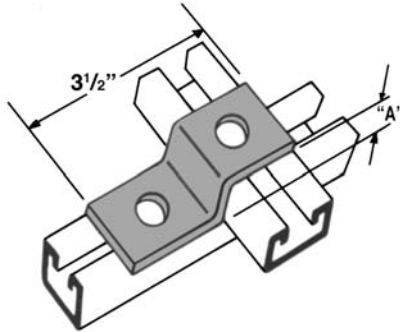

Discount Code D				Per 100 Pieces	
Part No.	A	Std. Pkg.	Wt.	GR	EG
AS 928	1 ³ / ₁₆ "	50	47	\$646.99	\$646.99

AS 929 "U" SUPPORT

Use With AS 500
and AS 520.

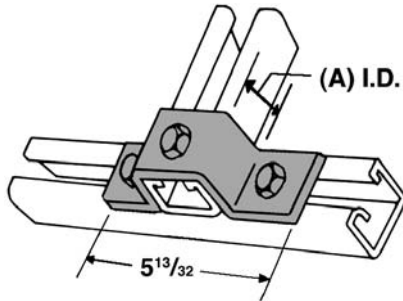

Discount Code D				Per 100 Pieces	
Part No.	A	Std. Pkg.	Wt.	GR	EG
AS 929	1 ³ / ₁₆ "	25	71	\$914.98	\$914.98

AS 930 TYPE "A" END CAP

Use With AS 500 Channel.

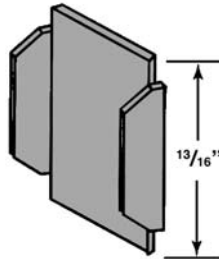

Discount Code D			Per 100 Pieces	
Part No.	Std. Pkg.	Wt.	PG	
AS 930	200	5	\$118.00	

AS 978 "U" SUPPORT

Use With AS 400.

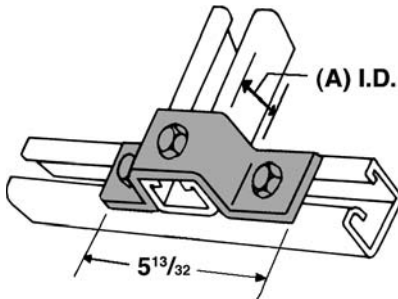

Discount Code D				Per 100 Pieces	
Part No.	A	Std. Pkg.	Wt.	GR	EG
AS 978	1"	20	71	\$1,013.98	\$1,013.98

AS 993 INSIDE CLEVIS

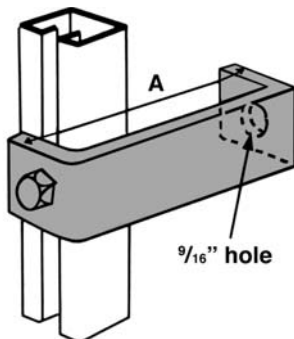

Discount Code D				Per 100 Pieces	
Part No.	A	Std. Pkg.	Wt.	GR	EG
AS 993	4"	25	78	\$958.98	\$958.98
AS 993	5"	25	89	\$1,045.98	\$1,045.98
AS 993	6"	25	101	\$1,151.97	\$1,151.97
AS 993	7"	25	112	\$1,255.97	\$1,255.97
AS 993	8"	25	124	\$1,320.97	\$1,320.97

SECTION 3 – FITTINGS AND ACCESSORIES

AS 998 "I" BEAM CLAMP

Includes Set Screw.

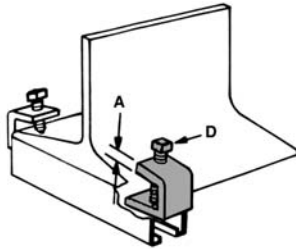

Discount Code D				Per 100 Pieces		
Part No.	A	D	Load Rating	Std. Pkg.	Wt.	EG
AS 998	3/8"	1/2 x 13 x 1 1/2	500	25	83	\$1,140.97

AS 2064 DOUBLE COLUMN POST BASE

Use With AS 100,
AS 200BTB,
AS 200STS,
AS 200BTS,
AS 200STSR.

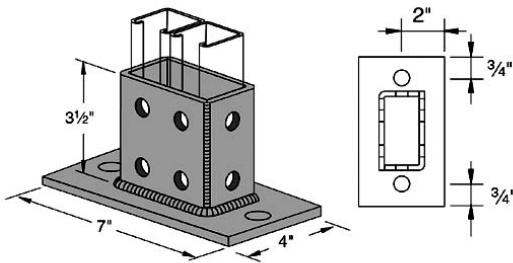

Discount Code D			Per 100 Pieces	
Part No.	Std. Pkg.	Wt.	GR	EG
AS 2064	5	311	\$6,428.85	\$6,550.85

AS 2112 CROSS CONNECTOR

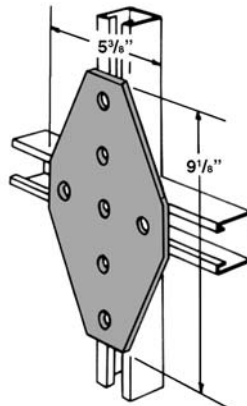

Discount Code D			Per 100 Pieces	
Part No.	Std. Pkg.	Wt.	GR	EG
AS 2112	10	240	\$3,031.93	\$3,031.93

AS 2119 "U" CONNECTOR

Use With AS 200 and AS 210.

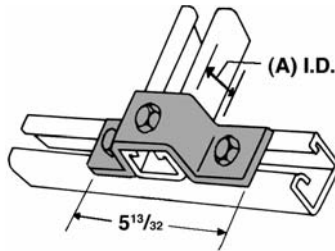

Discount Code D			Per 100 Pieces		
Part No.	A	Std. Pkg.	Wt.	GR	EG
AS 2119	1 7/8"	25	95	\$1,451.97	\$1,451.97

AS 2128 RH & LH SIX HOLE CORNER CONNECTOR

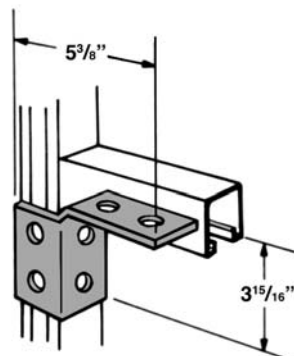

Discount Code D			Per 100 Pieces	
Part No.	Std. Pkg.	Wt.	GR	EG
AS 2128 RH	10	119	\$1,971.95	\$1,971.95
AS 2128 LH	10	119	\$1,971.95	\$1,971.95

When Ordering, Specify RH or LH.

FITTINGS

LEGEND:
GR: Painted Green
EG: Electro-Galvanized

PG: Pre-Galvanized
AL: Aluminum
HG: Hot Dipped Galvanized

PL: Plain
SS: Stainless Steel
ZD: Zinc Dichromate



SECTION 3 – FITTINGS AND ACCESSORIES

FITTINGS

**AS 2144
CORNER ANGLE**

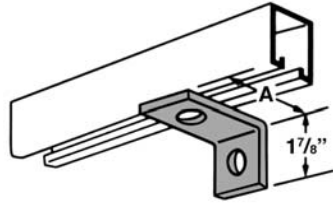

Discount Code D		Per 100 Pieces			
Part No.	A	Std. Pkg.	Wt.	GR	EG
AS 2144	3"	25	49	\$649.98	\$649.98
AS 2144	3 1/2"	25	54	\$719.98	\$719.98
AS 2144	4"	25	61	\$747.98	\$747.98

**AS 2190
FLAT CORNER CONNECTOR**

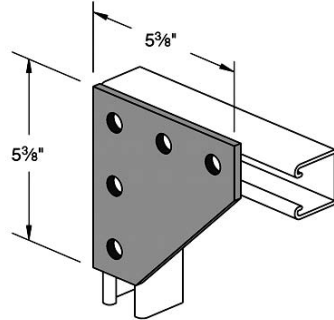

Discount Code D		Per 100 Pieces			
Part No.	Std. Pkg.	Wt.	GR	EG	
AS 2190	20	150	\$2,001.95	\$2,001.95	

**AS 2401 THRU
AS 2403
LADDER RUNG**

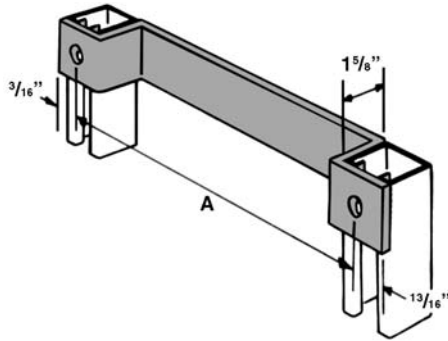

Discount Code D		Per 100 Pieces			
Part No.	A	Std. Pkg.	Wt.	GR	HG
AS 2401	12"	10	186	\$1,942.96	\$2,248.95
AS 2402	15"	20	221	\$1,993.95	\$2,351.95
AS 2403	18"	20	254	\$2,300.95	\$2,453.94

**AS 2404 THRU
AS 2408 WALL
LADDER BRACKET**

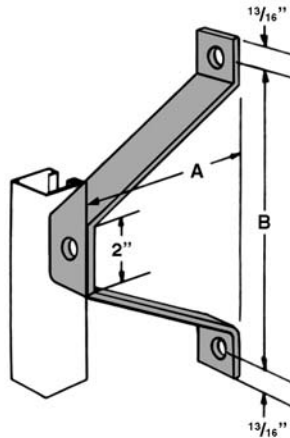

Discount Code D		Per 100 Pieces				
Part No.	A	B	Std. Pkg.	Wt.	GR	HG
AS 2404	2 3/8"	6"	10	113	\$1,379.97	\$1,512.97
AS 2405	4 3/8"	8"	10	164	\$1,891.96	\$2,003.95
AS 2406	6 3/8"	10"	10	216	\$2,351.95	\$2,504.94
AS 2407	8 3/8"	12"	10	267	\$2,606.94	\$2,780.94
AS 2408	10 3/8"	14"	10	318	\$2,984.93	\$3,291.92

**AS 2421
45° STAIR
TREAD
SUPPORT**

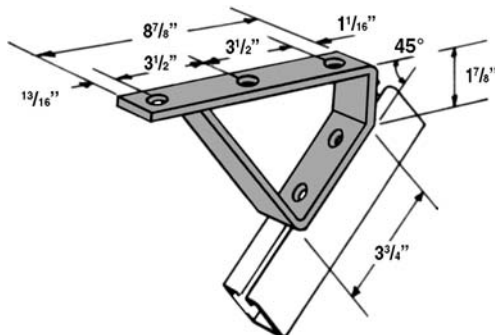

Discount Code D		Per 100 Pieces			
Part No.	Std. Pkg.	Wt.	GR	HG	
AS 2421 45DEG	20	220	\$2,862.93	\$3,066.93	

SECTION 3 – FITTINGS AND ACCESSORIES

AS 2422
37 1/2°
STAIR
TREAD
SUPPORT

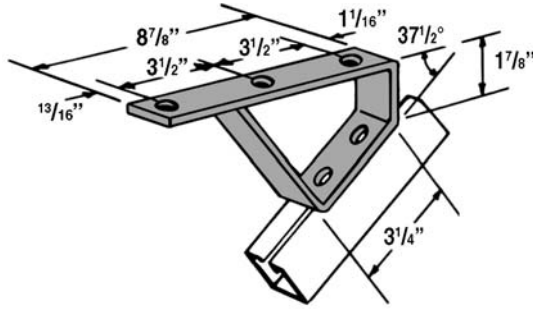

Discount Code D			Per 100 Pieces		
Part No.	Std. Pkg.	Wt.	GR	HG	
AS 2422 37 1/2 DEG	25	213	\$2,811.94	\$2,811.94	

AS 2504
SQUARE WASHER
WITH
CHANNEL GUIDE

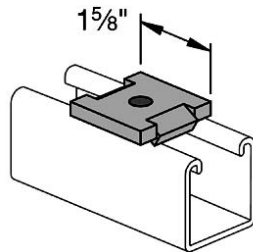

Discount Code D			Per 100 Pieces		
Part No.	Size	Std. Pkg.	Wt.	GR	EG
AS 2504	1/4"	100	18	\$272.99	\$272.99
AS 2504	3/8"	100	18	\$238.99	\$238.99
AS 2504	1/2"	100	17	\$238.99	\$238.99

AS 2511
END CAP WITH
KNOCK OUT

AS 2511 1 — Use With AS 100.
AS 2511 2 — Use With AS 200
and AS 210.
AS 2511 3 — Use with AS 300.

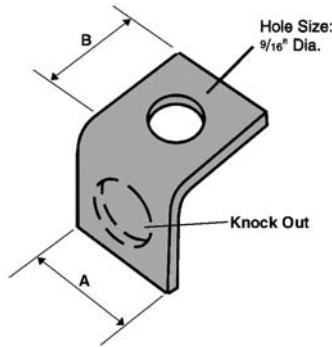

Discount Code D			Per 100 Pieces		
Part No.	A	B	Std. Pkg.	Wt.	EG
AS 2511 1	3 1/4"	1 3/4"	50	3.1	\$1,018.98
AS 2511 2	1 5/8"	1 3/4"	50	2.7	\$779.98
AS 2511 3	1 5/8"	1 3/4"	50	2.6	\$947.98

AS 2520
TWO HOLE
ADJUSTMENT
ANGLE

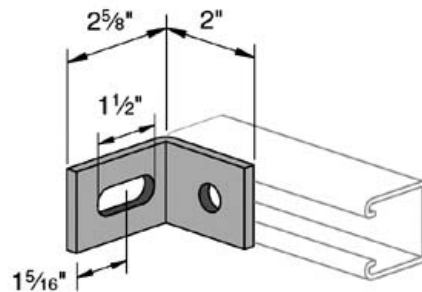

Discount Code D			Per 100 Pieces		
Part No.	Std. Pkg.	Wt.	GR	EG	
AS 2520	25	42	\$775.98	\$775.98	

AS 2521
TWO
WHEEL
TROLLEY

Use With AS 200.

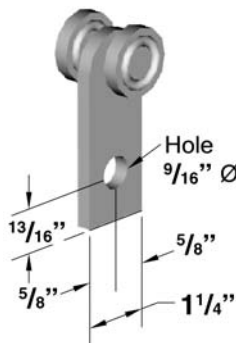

Discount Code D			Per 100 Pieces		
Part No.	Load Rating	Std. Pkg.	Wt.	EG	
AS 2521	300	20	46	\$4,543.90	

FITTINGS

LEGEND:
GR: Painted Green
EG: Electro-Galvanized

PG: Pre-Galvanized
AL: Aluminum
HG: Hot Dipped Galvanized

PL: Plain
SS: Stainless Steel
ZD: Zinc Dichromate

SECTION 3 – FITTINGS AND ACCESSORIES

FITTINGS

AS 2522 FOUR WHEEL TROLLEY

Use With AS 200.

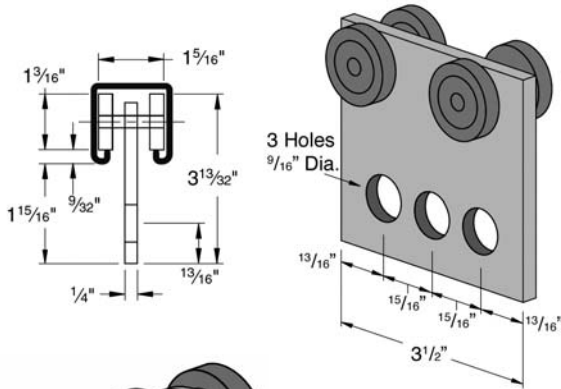

Discount Code D		Per 100 Pieces			
Part No.	Load Rating	Std. Pkg.	Wt.	EG	
AS 2522	600	10	110	\$6,837.84	

AS 2524 TWO WHEEL LIGHT DUTY TROLLEY

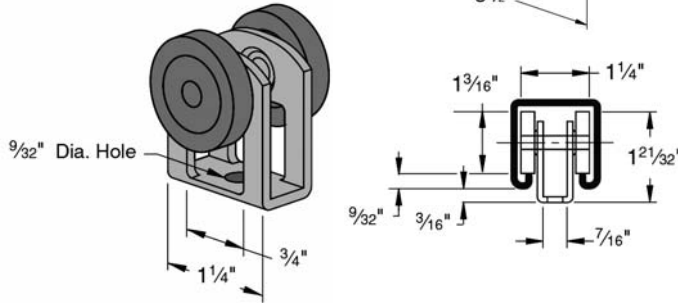

Discount Code D		Per 100 Pieces			
Part No.	Load Rating	Std. Pkg.	Wt.	EG	
AS 2524	50	25	21	\$3,169.93	

AS 2525 FOUR WHEEL LIGHT DUTY TROLLEY

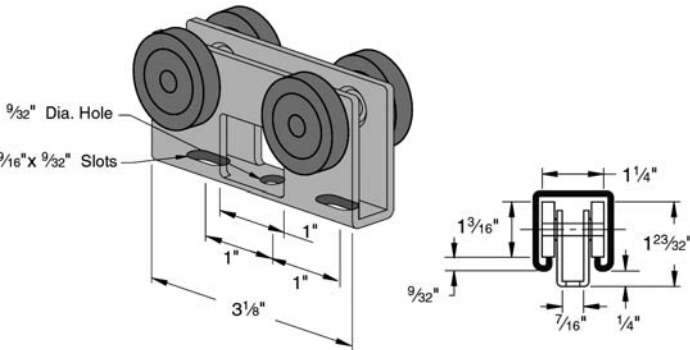

Discount Code D		Per 100 Pieces			
Part No.	Load Rating	Std. Pkg.	Wt.	EG	
AS 2525	100	25	55	\$4,702.89	

AS 2528 TROLLEY BEAM STANDARD SUPPORT

Use With AS 200 and AS 210 Channels.

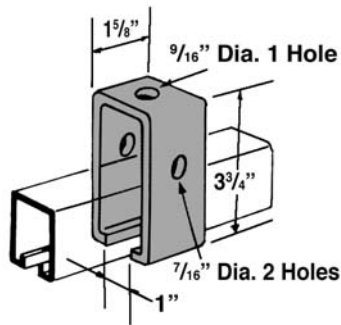

Discount Code D		Per 100 Pieces			
Part No.	Load Rating	Std. Pkg.	Wt.	GR	EG
AS 2528	600	10	102	\$2,000.95	\$2,000.95

AS 2528-1 TROLLEY BEAM JOINT SUPPORT

Use With AS 200 and AS 210 Channels.

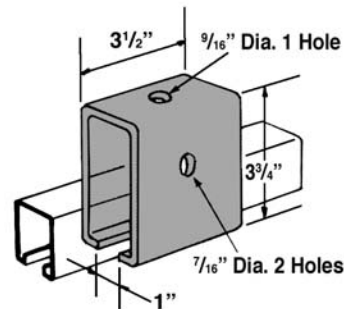

Discount Code D		Per 100 Pieces			
Part No.	Load Rating	Std. Pkg.	Wt.	GR	EG
AS 2528-1	2500	10	220	\$2,711.94	\$2,711.94

SECTION 3 – FITTINGS AND ACCESSORIES

**AS 2545
SLOTTED
90° ANGLE**

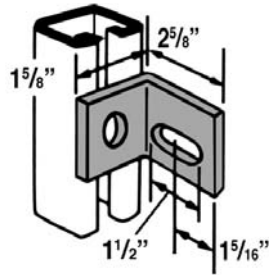

Discount Code D			Per 100 Pieces	
Part No.	Std. Pkg.	Wt.	GR	EG
AS 2545	50	38	\$693.98	\$693.98

**AS 2560, AS 2561
CONDUIT
CONNECTOR
FITTING
ASSEMBLY**

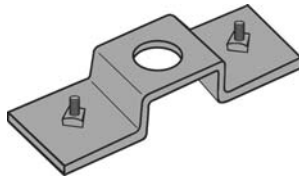

Discount Code D			Per 100 Pieces	
Part No.	Use With	Std. Pkg.	Wt.	EG
AS 2560	1/2" Conduit	50	36	\$1,093.97
AS 2561	3/4" Conduit	25	36	\$1,209.97

**AS 2580
TYPE "A"
END CAP**

Use With AS 150.

This item sold only in full box quantities.

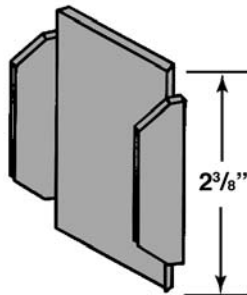

Discount Code D		Per 100 Pieces	
Part No.	Std. Pkg.	Wt.	PG
AS 2580	100	18	\$480.99

**AS 2601
"Z" SUPPORT**

Use With AS 150.

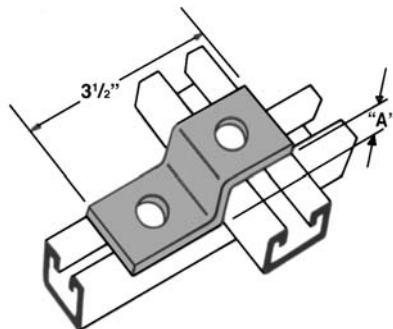

Discount Code D			Per 100 Pieces		
Part No.	A	Std. Pkg.	Wt.	GR	HG
AS 2601	27/16"	20	67	\$1,135.97	\$1,135.97

**AS 2623
SWIVEL
ADAPTER**

Use With AS 2622 Beam Clamp.

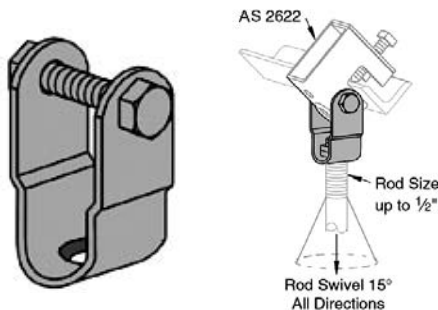

Discount Code D			Per 100 Pieces	
Part No.	Load Rating	Std. Pkg.	Wt.	EG
AS 2623	300	50	31	\$475.99

FITTINGS

LEGEND:
GR: Painted Green
EG: Electro-Galvanized

PG: Pre-Galvanized
AL: Aluminum
HG: Hot Dipped Galvanized

PL: Plain
SS: Stainless Steel
ZD: Zinc Dichromate

SECTION 3 – FITTINGS AND ACCESSORIES

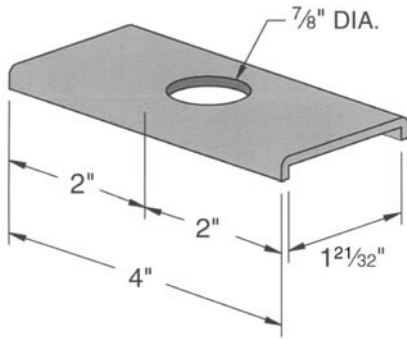

**AS 2627
 SPACER
 CLEVIS**

Discount Code D		Per 100 Pieces			
Part No.	Std. Pkg.	Wt.	EG		
AS 2627	25	24	\$643.99		

FITTINGS

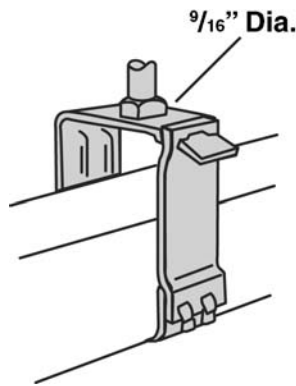

**AS 2631
 SWING GATE
 FIXTURE HANGER**

Use With AS 200, AS 210,
 AS 300, AS 400,
 and AS 500.

Discount Code D		Per 100 Pieces			
Part No.	Size	Load Rating	Std. Pkg.	Wt.	EG
AS 2631	9/16"	90	20	27	\$671.98

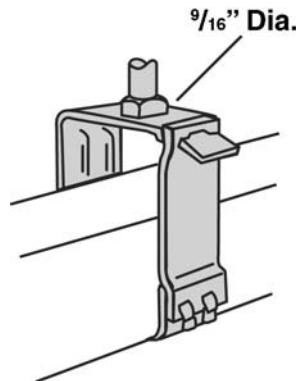

**AS 2631D
 SWING GATE
 FIXTURE HANGER**

Use With AS 100, AS 150,
 AS 200BTB, AS 210BTB.

Discount Code D		Per 100 Pieces			
Part No.	Size	Load Rating	Std. Pkg.	Wt.	EG
AS 2631 D	9/16"	90	20	33	\$872.98

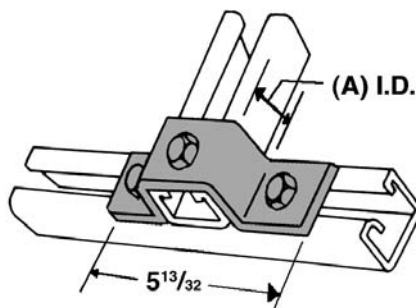

**AS 2648
 "U" SUPPORT**

Use With AS 150.

Discount Code D		Per 100 Pieces			
Part No.	A	Std. Pkg.	Wt.	GR	EG
AS 2648	2 7/16"	25	108	\$1,705.96	\$1,705.96

SECTION 3 – FITTINGS AND ACCESSORIES

AS 2651 BEAM CLAMP

T1 Use With AS 200, AS 210, AS 300, AS 400, AS 500, AS 520.
T2 Use With AS 100, AS 150, and AS 200BTB.

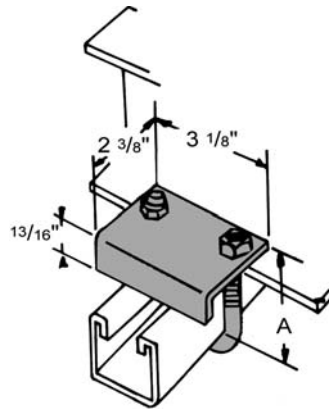

Discount Code D				Per 100 Pieces	
Part No.	A	Load Rating	Std. Pkg.	Wt.	EG
AS 2651 T1	3 3/8"	1000	25	80	\$754.98
AS 2651 T2	5"	1000	25	80	\$911.98

This item sold only in full box quantities.

AS 2654, AS 2654 A COLUMN ATTACHMENT

Use AS 2654 With AS 200.
Use AS 2654 A With AS 500.

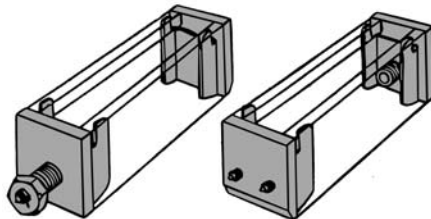

Discount Code D				Per 100 Pieces	
Part No.	Slip Rating	Std. Pkg.	Wt.	GR	EG
AS 2654	800	25 pair	41	\$2,384.94	\$2,384.94
AS 2654 A	800	25 pair	41	\$2,625.94	\$2,625.94

AS 2656 "U" BOLT BEAM CLAMP WITH HOOK

Specify 6" or 12" Max. Flange Width.
T1 Use With AS 200, AS 210, AS 300, AS 400, AS 500, and AS 520.
T2 Use With AS 100, AS 150, and AS 200BTB.

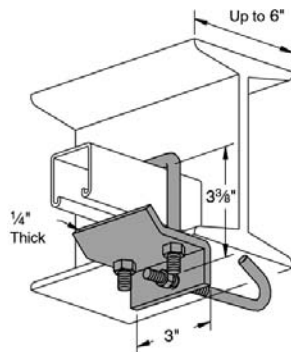

Discount Code D		Per 100 Pieces		
Part No.	Std. Pkg.	Wt.	EG	
AS 2656 T1 6	10	130	\$1,887.96	
AS 2656 T1 12	10	142	\$1,952.95	
AS 2656 T2 6	10	141	\$1,961.95	
AS 2656 T2 12	10	153	\$2,312.95	

AS 2657 DOUBLE "U" BOLT BEAM CLAMP

Specify 6" or 12" Max. Flange Width.
T1 Use With AS 200, AS 210, AS 300, AS 400, AS 500, and AS 520.
T2 Use With AS 100, AS 150, and AS 200BTB.

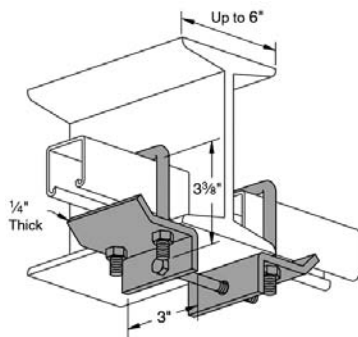

Discount Code D		Per 100 Pieces		
Part No.	Std. Pkg.	Wt.	EG	
AS 2657 T1 6	10	204	\$3,517.92	
AS 2657 T1 12	10	210	\$3,637.92	
AS 2657 T2 6	10	226	\$3,859.91	
AS 2657 T2 12	10	232	\$3,983.91	

AS 3013 SINGLE COLUMN POST BASE

Use With AS 200 and AS 210.

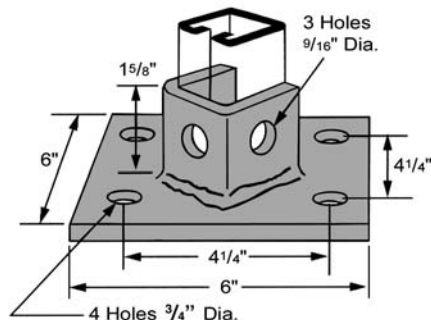

Discount Code D				Per 100 Pieces	
Part No.	Std. Pkg.	Wt.	GR	EG	
AS 3013	10	307	\$4,067.91	\$4,067.91	
AS 3013 SQ	5	307	\$4,067.91	\$4,067.91	

Diagram shown is a AS 3013.

FITTINGS

LEGEND:
GR: Painted Green
EG: Electro-Galvanized

PG: Pre-Galvanized
AL: Aluminum
HG: Hot Dipped Galvanized

PL: Plain
SS: Stainless Steel
ZD: Zinc Dichromate



SECTION 3 – FITTINGS AND ACCESSORIES

FITTINGS

AS 3025 POST BASE

Use With AS 200 and AS 210.

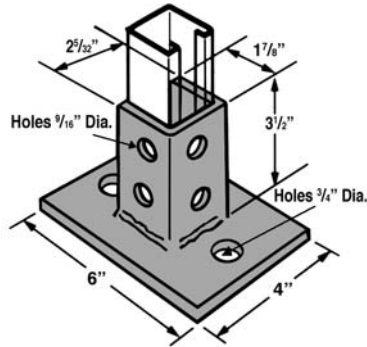

Discount Code D		Per 100 Pieces		
Part No.	Std. Pkg.	Wt.	GR	EG
AS 3025	10	358	\$3,622.92	\$3,622.92
AS 3025 FL	10	358	\$3,522.92	\$3,522.92

This item sold only in full box quantities.
 Diagram shown is a AS 3025.

AS 3029 DOUBLE COLUMN POST BASE

Use With All 3 1/4" Channels

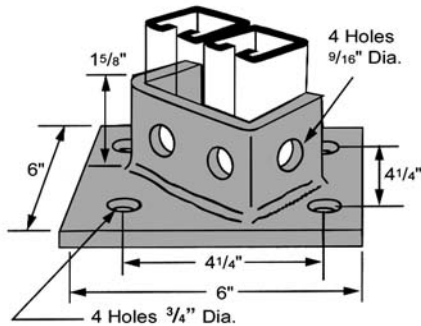

Discount Code D		Per 100 Pieces		
Part No.	Std. Pkg.	Wt.	GR	EG
AS 3029	5	325	\$4,572.89	\$4,572.89

AS 3033 POST BASE

Use With AS 200 and AS 210.

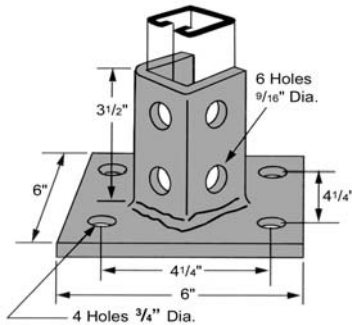

Discount Code D		Per 100 Pieces		
Part No.	Std. Pkg.	Wt.	GR	EG
AS 3033	10	373	\$3,927.91	\$4,039.91
AS 3033 SQ	10	373	\$3,927.91	\$4,039.91

This item sold only in full box quantities.
 Diagram shown is a AS 3033.

AS 3040 POST BASE

Use With AS 200 and AS 210.

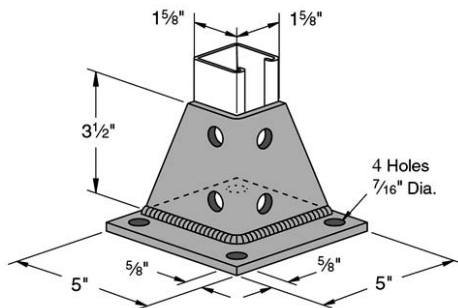

Discount Code D		Per 100 Pieces		
Part No.	Std. Pkg.	Wt.	GR	EG
AS 3040	10	297	\$4,156.90	\$4,156.90

AS 3049 TWO HOLE SLOTTED 90° CORNER CONNECTOR

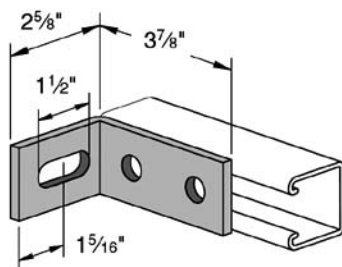

Discount Code D		Per 100 Pieces		
Part No.	Std. Pkg.	Wt.	GR	EG
AS 3049	25	66	\$933.98	\$933.98

SECTION 3 – FITTINGS AND ACCESSORIES

**AS 3060
OFFSET
CONNECTOR**

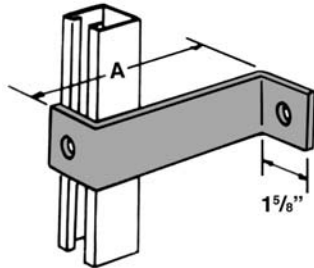

Discount Code D		Per 100 Pieces			
Part No.	A	Std. Pkg.	Wt.	GR	EG
AS 3060	4"	25	81	\$1,121.97	\$1,121.97
AS 3060	5"	25	92	\$1,178.97	\$1,178.97
AS 3060	6"	25	104	\$1,241.97	\$1,241.97
AS 3060	7"	25	115	\$1,309.97	\$1,309.97
AS 3060	8"	25	127	\$1,645.96	\$1,645.96

**AS 3064
DOUBLE COLUMN
POST BASE**

Use With All 3/4" Channels.

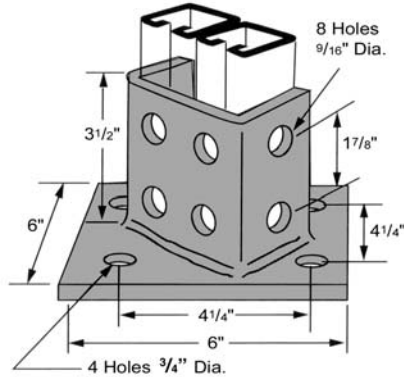

Discount Code D		Per 100 Pieces		
Part No.	Std. Pkg.	Wt.	GR	EG
AS 3064	10	408	\$5,813.87	\$5,813.87

**AS 3164
DOUBLE CHANNEL
BRACKET SUPPORT**

Use With All 3/4" Channels.

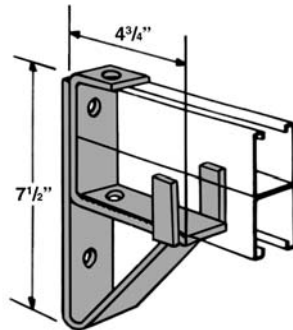

Discount Code D		Per 100 Pieces		
Part No.	Std. Pkg.	Wt.	GR	EG
AS 3164	10	273	\$6,879.84	\$6,879.84

**AS 3373
UNIVERSAL
ANGLE BRACKET**

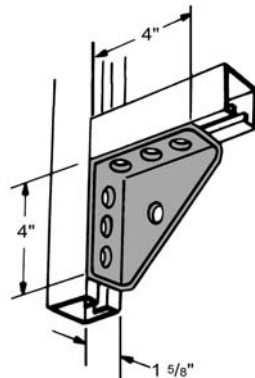

Discount Code D		Per 100 Pieces		
Part No.	Std. Pkg.	Wt.	GR	EG
AS 3373	25	134	\$1,072.98	\$1,072.98

This item sold only in full box quantities.
For Load Rating, see page 74.

**AS 6153
SAFETY END CAP**

- 1 — Use With AS 100.
- 2 — Use With AS 200 and AS 210.
- 3 — Use With AS 300.
- 5 — Use With AS 500.

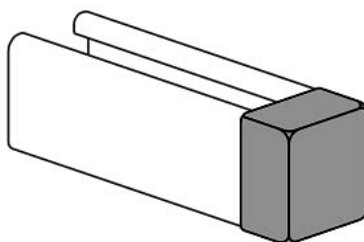

Discount Code D		Per 100 Pieces			
Part No.	Size	Std. Pkg.	Wt.	Red	White
AS 6153	1	100	5.0	\$821.98	\$821.98
AS 6153	2	100	2.8	\$782.98	\$782.98
AS 6153	3	100	2.5	\$782.98	\$782.98
AS 6153	5	100	2.0	\$803.99	\$803.99

This item sold only in full box quantities.

LEGEND:
GR: Painted Green
EG: Electro-Galvanized

PG: Pre-Galvanized
AL: Aluminum
HG: Hot Dipped Galvanized

PL: Plain
SS: Stainless Steel
ZD: Zinc Dichromate



SECTION 3 – FITTINGS AND ACCESSORIES

FITTINGS

**AS 9400
 ADJUSTABLE
 BASE**

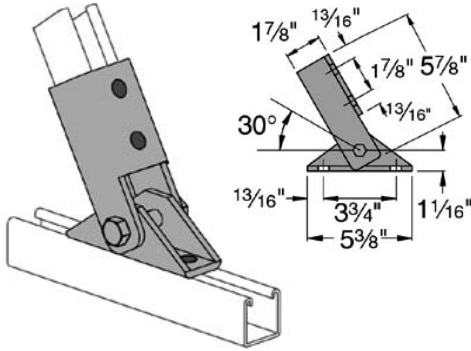

Discount Code D			Per 100 Pieces	
Part No.	Std. Pkg.	Wt.	GR	EG
AS 9400	10	307	\$3,864.91	\$3,864.91

**AS 9402
 TWO HOLE
 HINGE
 CONNECTOR**

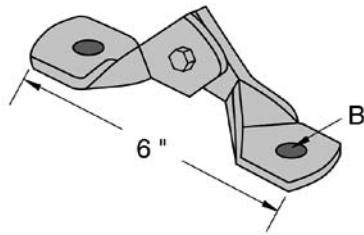

Discount Code D			Per 100 Pieces	
Part No.	B	Std. Pkg.	Wt.	EG
AS 9402	1/2"	15	90	\$3,584.92
AS 9402	5/8"	15	88	\$4,015.91
AS 9402	3/4"	15	86	\$4,138.90

**AS 9403
 THREE HOLE
 HINGE
 CONNECTOR**

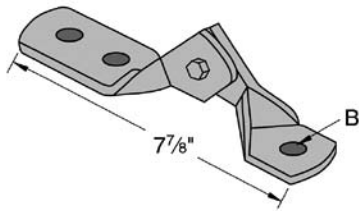

Discount Code D			Per 100 Pieces	
Part No.	B	Std. Pkg.	Wt.	EG
AS 9403	1/2"	15	108	\$3,895.91
AS 9403	5/8"	15	107	\$4,260.90
AS 9403	3/4"	15	106	\$4,382.90

**AS 9404
 FOUR HOLE
 HINGE
 CONNECTOR**

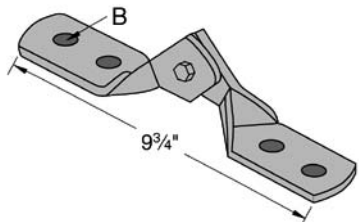

Discount Code D			Per 100 Pieces	
Part No.	B	Std. Pkg.	Wt.	EG
AS 9404	1/2"	10	126	\$4,138.90

SECTION 4 – PIPE & CONDUIT SUPPORTS

**AS 51
RIGHT ANGLE
PIPE OR
CONDUIT
CLAMP**

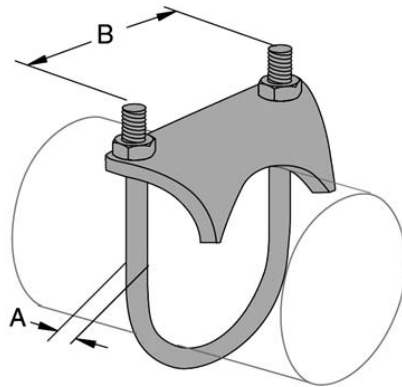

Discount Code D		Per 100 Pieces				
Part No.	Size	A Dia.	B	Std. Pkg.	Wt.	EG
AS 51	3/8"	5/16"	15/16"	50	25	\$786.98
AS 51	1/2"	5/16"	13/16"	50	41	\$731.98
AS 51	3/4"	5/16"	17/16"	50	42	\$736.98
AS 51	1"	5/16"	111/16"	50	47	\$797.98
AS 51	1 1/4"	5/16"	2"	50	54	\$919.98
AS 51	1 1/2"	5/16"	25/16"	50	57	\$1,097.97
AS 51	2"	3/8"	23/16"	50	85	\$1,435.97
AS 51	2 1/2"	3/8"	33/8"	50	106	\$1,459.97
AS 51	3"	3/8"	41/8"	50	110	\$1,951.95
AS 51	3 1/2"	3/8"	45/8"	50	128	\$2,724.94
AS 51	4"	3/8"	51/8"	50	140	\$2,992.93

This item sold only in full box quantities.

**FIG. 67
PIPE OR
CONDUIT
HANGER**

Size range 1/2" thru 6".



Part No.
Fig. 67 For Prices, See Anvil International Pipe Hanger List Price Sheet.

**FIG. 69
SWIVEL RING
HANGER**

Size range 1/2" thru 4".



Part No.
Fig. 69 For Prices, See Anvil International Pipe Hanger List Price Sheet.

**FIG. 137
"U" BOLT
WITH NUTS
LONG TANGENT**

Size range 1/2" thru 4".



Part No.
Fig. 137 For Prices, See Anvil International Pipe Hanger List Price Sheet.

LEGEND:
GR: Painted Green
EG: Electro-Galvanized

PG: Pre-Galvanized
AL: Aluminum
HG: Hot Dipped Galvanized

PL: Plain
SS: Stainless Steel
ZD: Zinc Dichromate

SECTION 4 – PIPE & CONDUIT SUPPORTS

**AS 270
 CONDUIT CLAMP**

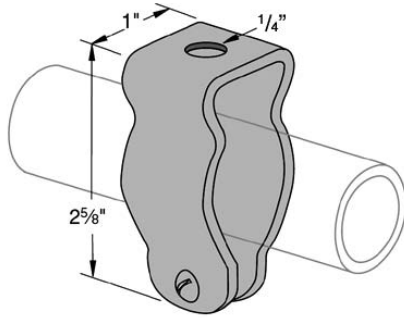

Discount Code D		Per 100 Pieces			
Part No.	A	Std. Pkg.	Wt.	EG	
AS 270	3/8" - 1/2"	50	6		\$103.00
AS 270	3/4"	50	8		\$119.00
AS 270	1"	50	9		\$130.00
AS 270	1 1/4"	25	11		\$168.00
AS 270	1 1/2"	25	19		\$245.99
AS 270	2"	25	27		\$310.99

This item sold only in full box quantities.

AS 815 (6" TO 18" PIPE) DOUBLE ROLLER PIPE SUPPORT

Order Nuts and Bolts Separately.

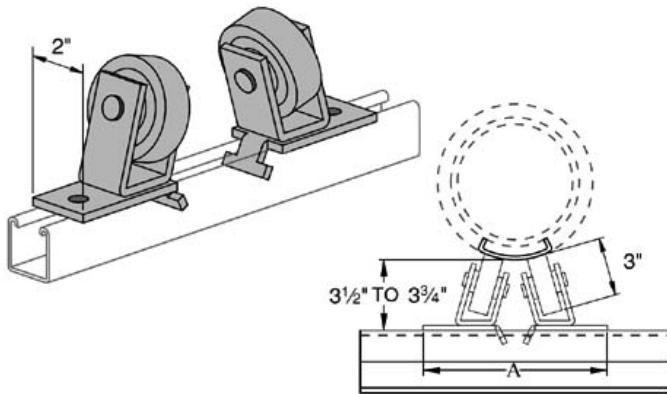

Discount Code D		Per 100 Pieces			
Part No.	Load Rating	Std. Pkg.	Wt.	GR	HG
AS 815 6-18	1500	5 Pr.	680	\$9,688.78	POA

For "A" Dimension Recommendations, See Chart On Page 69.

PIPE/CONDUIT SUPPORTS

**AS 1000
 EMT CONDUIT
 CLAMPS**

This item sold only in full box quantities.

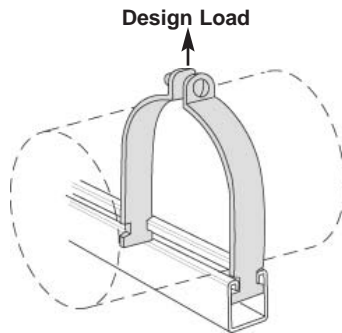

Discount Code B		Per 100 Pieces			
Part No.	Size	Load Rating	Std. Pkg.	Wt.	EG
AS 1000	1/2"	400	100	11	\$176.00
AS 1000	3/4"	400	100	12	\$184.00
AS 1000	1"	600	100	15	\$210.00
AS 1000	1 1/4"	600	100	18	\$234.99
AS 1000	1 1/2"	800	50	29	\$288.99
AS 1000	2"	800	50	33	\$304.99

This item sold only in full box quantities.

**AS 1000
 PRE-ASSEMBLED
 EMT CONDUIT
 CLAMPS**

This item sold only in full box quantities.

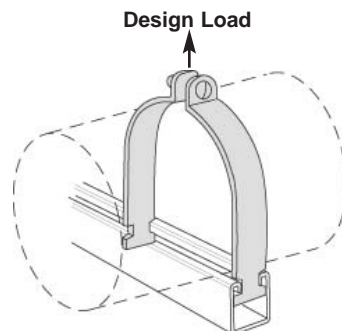

Discount Code B		Per 100 Pieces			
Part No.	Size	Load Rating	Std. Pkg.	Wt.	EG
AS 1000 AS	1/2"	400	100	11	\$190.00
AS 1000 AS	3/4"	400	100	12	\$194.00
AS 1000 AS	1"	600	100	15	\$224.99
AS 1000 AS	1 1/4"	600	100	18	\$252.99
AS 1000 AS	1 1/2"	800	50	29	\$306.99
AS 1000 AS	2"	800	50	33	\$326.99

SECTION 4 – PIPE & CONDUIT SUPPORTS

AS 1100 RIGID STEEL CONDUIT CLAMPS

Also For IMC and GRC.

This item sold only in full box quantities.

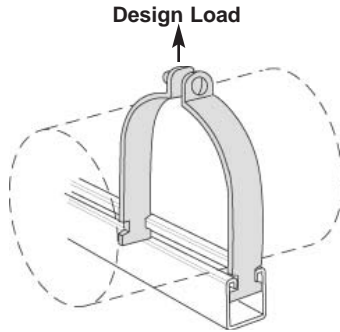

Discount Code B				Per 100 Pieces	
Part No.	Size	Load Rating	Std. Pkg.	Wt.	EG
AS 1100	3/8"	400	100	10	\$218.99
AS 1100	1/2"	400	100	11	\$176.00
AS 1100	3/4"	600	100	15	\$184.00
AS 1100	1"	600	100	17	\$210.00
AS 1100	1 1/4"	600	100	19	\$234.99
AS 1100	1 1/2"	800	50	29	\$288.99
AS 1100	2"	800	50	34	\$303.99
AS 1100	2 1/2"	800	50	40	\$344.99
AS 1100	3"	800	50	47	\$377.99
AS 1100	3 1/2"	1000	25	62	\$440.99
AS 1100	4"	1000	25	67	\$493.99
AS 1100	5"	1000	25	80	\$744.98
AS 1100	6"	1000	25	102	\$894.98
AS 1100	8"	1000	25	130	\$1,380.97
AS 1100	10"	1000	10	143	\$1,836.96
AS 1100	12"	1000	10	174	\$2,273.95

This item sold only in full box quantities.

AS 1100 PRE-ASSEMBLED RIGID STEEL CONDUIT AND PIPE CLAMPS

Also For IMC and GRC.

This item sold only in full box quantities.

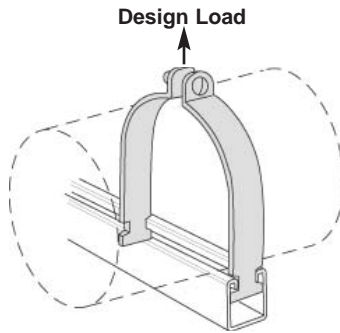

Discount Code B				Per 100 Pieces	
Part No.	Size	Load Rating	Std. Pkg.	Wt.	EG
AS 1100 AS	3/8"	400	100	10	\$233.99
AS 1100 AS	1/2"	400	100	11	\$189.00
AS 1100 AS	3/4"	600	100	15	\$194.00
AS 1100 AS	1"	600	100	17	\$222.99
AS 1100 AS	1 1/4"	600	100	19	\$251.99
AS 1100 AS	1 1/2"	800	50	29	\$305.99
AS 1100 AS	2"	800	50	34	\$322.99
AS 1100 AS	2 1/2"	800	50	40	\$366.99
AS 1100 AS	3"	800	50	47	\$401.99
AS 1100 AS	3 1/2"	1000	25	62	\$474.99
AS 1100 AS	4"	1000	25	67	\$523.99
AS 1100 AS	5"	1000	25	80	\$811.98
AS 1100 AS	6"	1000	25	102	\$1,021.98

PIPE/CONDUIT SUPPORTS

LEGEND:
GR: Painted Green
EG: Electro-Galvanized

PG: Pre-Galvanized
AL: Aluminum
HG: Hot Dipped Galvanized

PL: Plain
SS: Stainless Steel
ZD: Zinc Dichromate



SECTION 4 – PIPE & CONDUIT SUPPORTS

AS 1200 O.D. TUBING CLAMP

This item sold only in full box quantities.

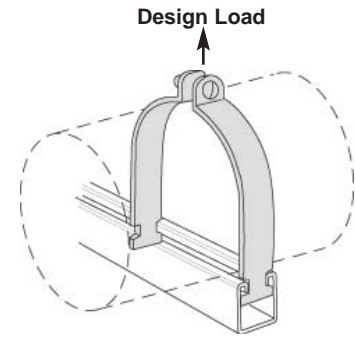

PIPE/CONDUIT SUPPORTS

Discount Code B		Per 100 Pieces				
Part No.	Size	Load Rating	Std. Pkg.	Wt.	EG	Copper Plated
AS 1200	1/4"	400	100	8	\$245.99	POA
AS 1200	3/8"	400	100	8	\$252.99	\$312.99
AS 1200	1/2"	400	100	9	\$256.99	\$320.99
AS 1200	5/8"	400	100	10	\$259.99	\$325.99
AS 1200	3/4"	400	100	11	\$268.99	POA
AS 1200	7/8"	400	100	12	\$279.99	\$354.99
AS 1200	1"	600	100	14	\$311.99	POA
AS 1200	1 1/8"	600	100	15	\$320.99	\$394.99
AS 1200	1 1/4"	600	100	16	\$325.99	POA
AS 1200	1 3/8"	600	100	17	\$334.99	\$458.99
AS 1200	1 1/2"	600	100	18	\$343.99	POA
AS 1200	1 5/8"	600	100	19	\$349.99	\$478.99
AS 1200	1 3/4"	800	50	29	\$455.99	POA
AS 1200	1 7/8"	800	50	28	\$455.99	POA
AS 1200	2"	800	50	31	\$463.99	POA
AS 1200	2 1/8"	800	50	32	\$463.99	\$649.98
AS 1200	2 1/4"	800	50	33	\$492.99	POA
AS 1200	2 3/8"	800	50	34	\$492.99	POA
AS 1200	2 1/2"	800	50	35	\$511.99	POA
AS 1200	2 5/8"	800	50	37	\$511.99	\$724.98
AS 1200	2 3/4"	800	50	38	\$414.99	POA
AS 1200	2 7/8"	800	50	40	\$537.99	POA
AS 1200	3"	800	50	41	\$565.99	POA
AS 1200	3 1/8"	800	50	43	\$579.99	\$792.98
AS 1200	3 1/4"	800	50	45	\$597.99	POA
AS 1200	3 3/8"	800	50	46	\$611.99	POA
AS 1200	3 1/2"	800	50	47	\$611.99	POA
AS 1200	3 5/8"	800	25	56	\$640.99	\$979.98
AS 1200	3 3/4"	800	25	58	\$705.98	POA
AS 1200	3 7/8"	1,000	25	60	\$801.98	POA
AS 1200	4"	1,000	25	62	\$801.98	POA
AS 1200	4 1/8"	1,000	25	62	\$886.98	\$982.98
AS 1200	4 1/4"	1,000	25	64	\$982.98	POA
AS 1200	4 3/8"	1,000	25	66	\$953.98	POA
AS 1200	4 1/2"	1,000	25	67	\$953.98	POA
AS 1200	4 5/8"	1,000	25	70	\$970.98	POA
AS 1200	4 3/4"	1,000	25	72	\$990.98	POA
AS 1200	4 7/8"	1,000	25	73	\$1,009.98	POA

Continued in next column

Continued from previous column						
Discount Code B		Per 100 Pieces				
Part No.	Size	Load Rating	Std. Pkg.	Wt.	EG	Copper Plated
AS 1200	5"	1,000	25	74	\$1,009.98	POA
AS 1200	5 1/8"	1,000	25	76	\$1,044.98	POA
AS 1200	5 1/4"	1,000	25	77	\$1,119.97	POA
AS 1200	5 3/8"	1,000	25	78	\$1,099.97	POA
AS 1200	5 1/2"	1,000	25	79	\$1,109.97	POA
AS 1200	5 5/8"	1,000	25	88	\$1,325.97	POA
AS 1200	5 3/4"	1,000	25	90	\$1,356.97	POA
AS 1200	5 7/8"	1,000	25	92	\$1,376.97	POA
AS 1200	6"	1,000	25	94	\$1,375.97	POA
AS 1200	6 1/8"	1,000	25	96	\$1,389.97	POA
AS 1200	6 1/4"	1,000	25	98	\$1,418.97	POA
AS 1200	6 3/8"	1,000	25	99	\$1,428.97	POA
AS 1200	6 1/2"	1,000	25	100	\$1,648.96	POA
AS 1200	6 5/8"	1,000	25	102	\$1,685.96	POA
AS 1200	6 3/4"	1,000	25	104	\$1,712.96	POA
AS 1200	6 7/8"	1,000	25	106	\$1,734.96	POA
AS 1200	7"	1,000	25	108	\$1,734.96	POA
AS 1200	7 1/8"	1,000	25	110	\$1,787.96	POA
AS 1200	7 1/4"	1,000	25	112	\$1,809.96	POA
AS 1200	7 3/8"	1,000	25	114	\$1,853.96	POA
AS 1200	7 1/2"	1,000	25	116	\$1,853.96	POA
AS 1200	7 5/8"	1,000	25	117	\$1,889.96	POA
AS 1200	7 3/4"	1,000	25	119	\$1,892.96	POA
AS 1200	7 7/8"	1,000	25	121	\$1,950.95	POA
AS 1200	8"	1,000	25	123	\$1,950.95	POA
AS 1200	8 1/8"	1,000	25	125	\$2,079.95	POA
AS 1200	8 1/4"	1,000	25	126	\$2,030.95	POA
AS 1200	8 3/8"	1,000	25	128	\$2,091.95	POA
AS 1200	8 1/2"	1,000	25	129	\$2,118.95	POA
AS 1200	8 5/8"	1,000	25	130	\$2,118.95	POA

This item sold only in full box quantities.

SECTION 4 – PIPE & CONDUIT SUPPORTS

AS 1300 UNIVERSAL PIPE CLAMP

This item sold only in full box quantities.

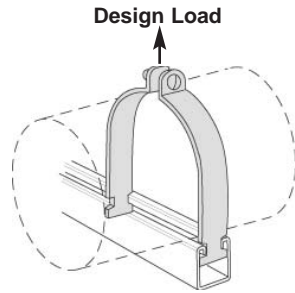

AS 1300 PRE-ASSEMBLED UNIVERSAL CLAMP

For EMT, IMC, GC, Pipe, or O.D. Tube.

This item sold only in full box quantities.

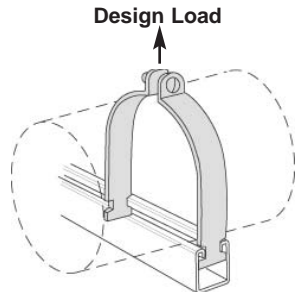

AS 1450 ONE HOLE CLAMP FOR O.D. TUBING

Use With 1 5/8" Wide Channel

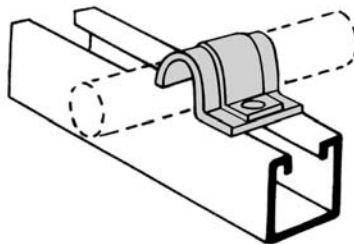

AS 1901 (1" - 8" PIPE) PIPE ROLLER SUPPORT

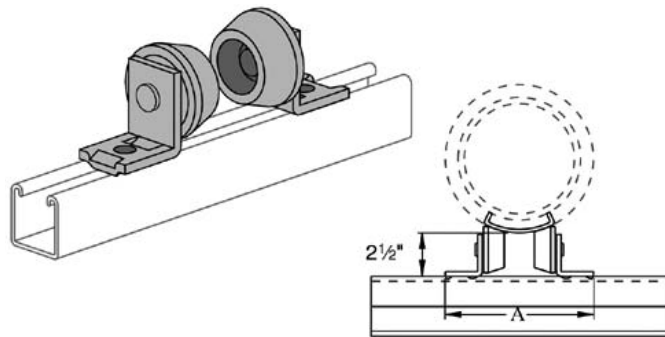

AS 1902 PIPE ROLLER SUPPORT

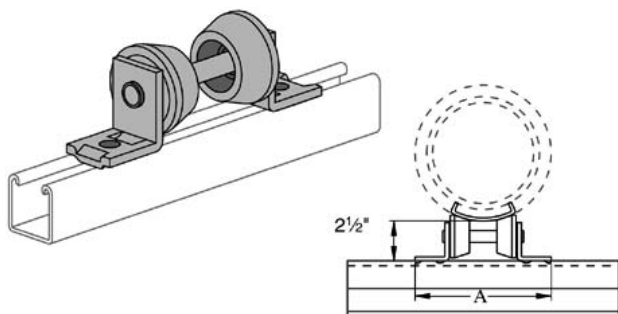

Discount Code B		Per 100 Pieces				
Part No.	Size	Load Rating	Std. Pkg.	Wt.	EG	
AS 1300	1/2"	250	100	10	\$176.00	
AS 1300	3/4"	400	100	11	\$184.00	
AS 1300	1"	400	100	12	\$210.00	
AS 1300	1 1/4"	400	100	18	\$234.99	
AS 1300	1 1/2"	500	100	20	\$288.99	
AS 1300	2"	500	100	22	\$304.99	

Discount Code B		Per 100 Pieces				
Part No.	Size	Load Rating	Std. Pkg.	Wt.	EG	
AS 1300 AS	1/2"	250	100	10	\$189.00	
AS 1300 AS	3/4"	400	100	11	\$194.00	
AS 1300 AS	1"	400	100	12	\$222.99	
AS 1300 AS	1 1/4"	400	100	18	\$249.99	
AS 1300 AS	1 1/2"	500	100	20	\$305.99	
AS 1300 AS	2"	500	100	22	\$324.99	

This item sold only in full box quantities.

Discount Code B		Per 100 Pieces			
Part No.	A	Std. Pkg.	Wt.	EG	
AS 1450	1/4"	100	4	\$242.99	
AS 1450	3/8"	100	5	\$245.99	
AS 1450	1/2"	100	6	\$260.99	
AS 1450	5/8"	100	8	\$309.99	
AS 1450	3/4"	100	9	\$324.99	
AS 1450	7/8"	50	10	\$340.99	
AS 1450	1"	50	11	\$358.99	

Discount Code D		Per 100 Pieces				
Part No.	Load Rating	Std. Pkg.	Wt.	GR	EG	
AS 1901	500	10 Pr.	268	\$4,738.89	\$4,738.89	

For "A" Dimension Recommendations, See Chart On Page 69.

Discount Code D		Per 100 Pieces					
Part No.	Size	A	Load Rating	Std. Pkg.	Wt.	GR	EG
AS 1902	1" - 2"	6 3/4"	750	10	299	\$7,740.82	\$7,269.83
AS 1902	2 1/2" - 3 1/2"	7 1/2"	750	10	304	\$6,066.86	\$6,066.86
AS 1902	4" - 6"	8 1/2"	750	10	311	\$6,073.86	\$6,073.86
AS 1902	8"	9 9/16"	750	10	319	\$6,195.86	\$6,195.86

For "A" Dimension Recommendations, See Chart On Page 69.

LEGEND:
GR: Painted Green
EG: Electro-Galvanized

PG: Pre-Galvanized
AL: Aluminum
HG: Hot Dipped Galvanized

PL: Plain
SS: Stainless Steel
ZD: Zinc Dichromate



SECTION 4 – PIPE & CONDUIT SUPPORTS

AS 1911 PIPE ROLLER

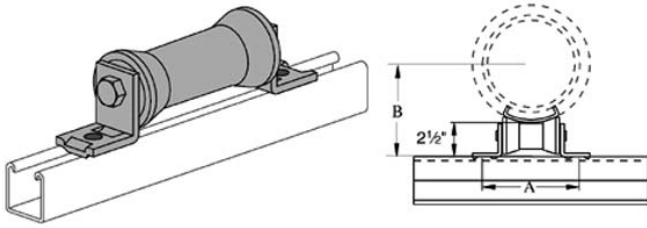

Discount Code D		Per 100 Pieces				
Part No.	Size	Load Rating	Std. Pkg.	Wt.	GR	HG
AS 1911	2"-3 1/2"	950	25	160	\$2,563.94	\$3,026.93
AS 1911	4"-6"	950	20	215	\$2,625.94	\$3,158.93
AS 1911	8"-10"	950	Bulk	525	\$4,961.89	\$6,941.84
AS 1911	12"-10"	950	Bulk	1,025	\$6,693.85	\$10,303.76

For "A" Dimension Recommendations, See Chart On Page 69.

AS 3101 THRU AS 3115 ONE PIECE CABLE AND CONDUIT CLAMP

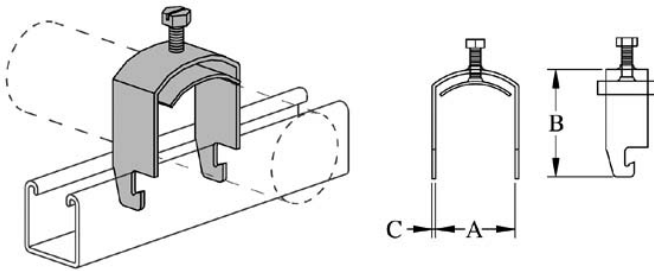

Discount Code D		Per 100 Pieces						
Part No.	Size	A	B	C	Std. Pkg.	Wt.	EG	
AS 3101	3/8"	7/16"	1 5/8"	14	100	6	\$440.99	
AS 3102	1/2"	9/16"	1 3/4"	14	100	7	\$463.99	
AS 3103	3/4"	1 3/16"	2"	14	100	12	\$482.99	
AS 3104	1"	1 1/16"	2 1/4"	14	100	15	\$509.99	
AS 3105	1 1/4"	1 5/16"	2 1/2"	14	100	19	\$545.99	
AS 3106	1 1/2"	1 9/16"	2 3/4"	14	100	20	\$629.99	
AS 3107	1 3/4"	1 13/16"	3"	12	100	25	\$751.98	
AS 3108	2"	2 1/16"	3 1/4"	12	100	35	\$828.98	
AS 3109	2 3/8"	2 7/16"	3 5/8"	12	75	41	\$1,081.98	
AS 3110	2 3/4"	2 13/16"	4"	12	75	60	\$1,161.97	
AS 3111	3 1/4"	3 5/16"	4 1/2"	12	75	64	\$1,514.97	
AS 3112	3 3/4"	3 13/16"	5"	12	50	91	\$1,795.96	
AS 3113	4"	4 1/16"	5 1/4"	12	40	100	\$1,867.96	
AS 3114	4 3/8"	4 7/16"	5 5/8"	12	30	115	\$1,960.95	
AS 3115	4 3/4"	4 13/16"	6"	12	30	125	\$2,126.95	

AS 3126 HOLD DOWN CLAMP

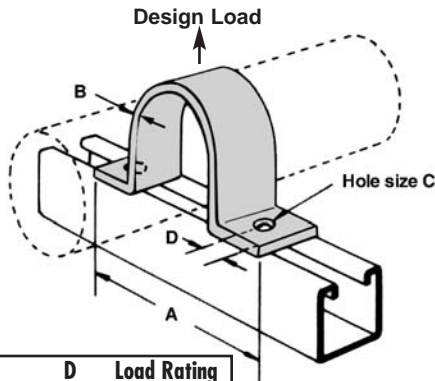

Size	B	C	D	Load Rating
1/2 - 1 1/2	1/8"	9/32"	7/16"	500
2 - 6	1/4"	13/32"	13/16"	1000

Discount Code B		Per 100 Pieces				
Part No.	Size	A	Std. Pkg.	Wt.	EG	
AS 3126	1/2"	27/8"	50	23	\$698.98	
AS 3126	3/4"	3 1/16"	50	26	\$720.98	
AS 3126	1"	3 11/32"	25	31	\$761.98	
AS 3126	1 1/4"	3 11/16"	25	35	\$792.98	
AS 3126	1 1/2"	3 29/32"	25	39	\$814.98	
AS 3126	2"	5 21/32"	25	94	\$1,281.97	
AS 3126	2 1/2"	6 5/32"	25	114	\$1,396.97	
AS 3126	3"	6 25/32"	25	133	\$1,498.97	
AS 3126	3 1/2"	7 9/32"	10	152	\$1,120.97	
AS 3126	4"	7 25/32"	Bulk	176	\$1,692.96	
AS 3126	5"	7 27/32"	Bulk	198	\$2,429.94	
AS 3126	6"	9 29/32"	Bulk	225	\$2,574.94	

AS 3138 PARALLEL PIPE CLAMP

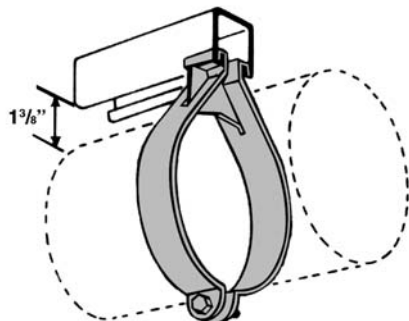

Discount Code B		Per 100 Pieces				
Part No.	Size	Load Rating	Std. Pkg.	Wt.	EG	
AS 3138	3/8"	300	50	27	\$1,172.97	
AS 3138	1/2"	300	50	29	\$1,067.98	
AS 3138	3/4"	300	50	30	\$1,038.98	
AS 3138	1"	400	50	31	\$1,093.97	
AS 3138	1 1/4"	400	50	38	\$1,226.97	
AS 3138	1 1/2"	500	50	40	\$1,408.97	
AS 3138	2"	500	25	47	\$1,545.96	
AS 3138	2 1/2"	500	25	66	\$1,706.96	
AS 3138	3"	500	25	78	\$1,802.96	
AS 3138	3 1/2"	500	25	87	\$1,908.96	
AS 3138	4"	500	25	90	\$2,107.95	

SECTION 4 – PIPE & CONDUIT SUPPORTS

**AS 3792
CUSHION STRIP**

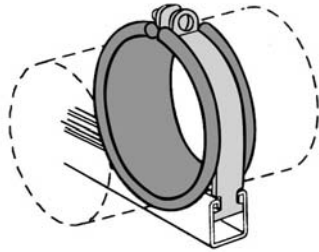

**AS 0040D
THRU AS 106P
CUSHION
CLAMP
ASSEMBLY**

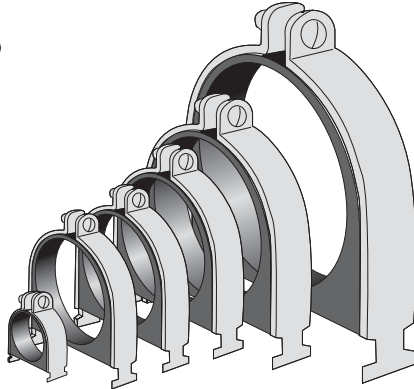

Discount Code D		Per 100 Boxes	
Part No.	Std. Pkg.	Wt.	EPDM
AS 3792	20 Ft./Box	253	\$15,299.65

Service Temperature -50°F to 275°F.

Discount Code F		Per 100 Pieces		
Part No.	O.D. Size (Pipe Size)	Std. Pkg.	Wt.	EG
AS 004OD*	¼"	25	10	\$625.62
AS 006ODN*	⅜"	25	11	\$625.62
AS 008ODN*	½"	25	13	\$625.62
AS 009P	(¼" Pipe)	25	13	\$639.29
AS 010ODN*	⅝"	25	14	\$639.29
AS 011P	(⅜" Pipe)	25	14	\$655.42
AS 012ODN*	¾"	25	14	\$655.42
AS 014P	(½" Pipe)	25	15	\$741.44
AS 014ODN*	⅞"	25	15	\$741.44
AS 016OD	1"	25	17	\$855.48
AS 017P	(¾" Pipe)	20	17	\$879.97
AS 018ODN*	1⅛"	20	18	\$879.97
AS 020OD	1¼"	20	18	\$1,157.28
AS 021P	(1" Pipe)	20	19	\$1,157.28
AS 022ODN*	1⅜"	20	20	\$1,029.56
AS 024OD	1½"	20	33	\$1,240.29
AS 026ODN*	1⅝"	20	35	\$1,244.24
AS 027P	(1¼" Pipe)	20	35	\$1,541.39
AS 028OD	1¾"	20	37	\$1,596.10
AS 030ODP	(1½" Pipe)	20	39	\$2,024.66
AS 032OD	2"	10	41	\$2,644.67
AS 034OD*	2⅛"	10	46	\$2,359.55
AS 038ODP	(2" Pipe)	10	47	\$2,735.88
AS 040OD	2½"	10	49	\$2,827.23
AS 042OD*	2⅝"	5	51	\$2,670.63
AS 046ODP	(2½" Pipe)	5	55	\$3,629.50
AS 048OD	3"	5	57	\$3,667.11
AS 050OD*	3⅜"	5	60	\$4,019.93
AS 056ODP	(3" Pipe)	5	55	\$5,663.34
AS 058OD	3⅝"	5	70	\$5,818.52
AS 064ODP	(3½" Pipe)	5	88	\$7,615.93
AS 066OD	4⅛"	5	94	\$7,590.49
AS 072ODP	(4" Pipe)	5	110	\$11,916.59
AS 082OD	5⅛"	5	125	\$16,731.68
AS 089P	(5" Pipe)	5	130	\$17,728.71
AS 098OD	6⅛"	5	130	\$22,483.35
AS 106P	(6" Pipe)	5	140	\$23,091.20

* Item sold only in full box quantities.
Service Temperature -65°F to 275°F.

LEGEND:
GR: Painted Green
EG: Electro-Galvanized

PG: Pre-Galvanized
AL: Aluminum
HG: Hot Dipped Galvanized

PL: Plain
SS: Stainless Steel
ZD: Zinc Dichromate



SECTION 5 – KLO-SHURE®

KLO-SHURE® INSULATION COUPLING CLEVIS HANGER/RING HANGER

The Klo-Shure® coupling supports tubing and secures insulation where clevis hangers are used. Metal clevis hanger or ring hanger not included. Used by permission.

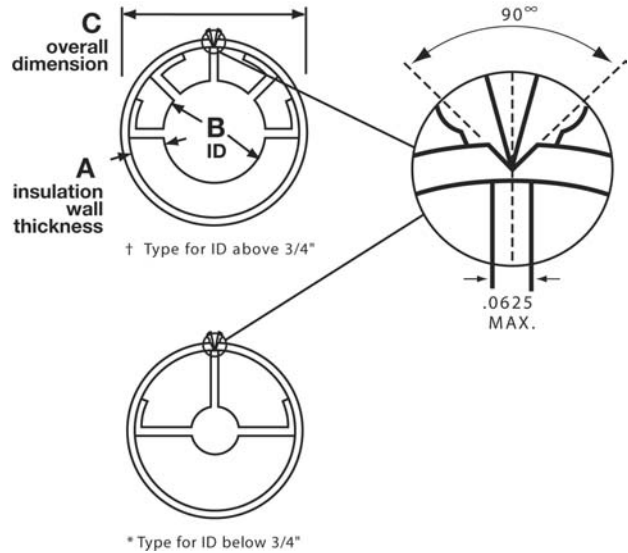
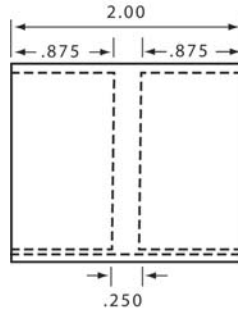

KLO-SHURE®

Discount Code F		Per 100 Pieces	
A	B	C	
		Klo-Shure	Overall
		Part No.	ID Dimension
Klo-Shure Clevis Hanger Coupling for 3/8" wall insulation	AS 03025	1/4" ID	1.12 \$336.00
	AS 03037	3/8" ID	1.25 \$378.00
	AS 03050	1/2" ID	1.37 \$420.00
	AS 03062	5/8" ID	1.50 \$472.00
	AS 03075	3/4" ID	1.62 \$525.00
	AS 03087	7/8" ID	1.75 \$577.00
	AS 03100	1" ID	1.87 \$608.00
	AS 03112	1 1/8" ID	2.00 \$629.00
	AS 03137	1 3/8" ID	2.25 \$713.00
	AS 03162	1 5/8" ID	2.50 \$1,154.00
AS 03212	2 1/8" ID	3.00 \$1,720.00	
Klo-Shure Clevis Hanger Coupling for 1/2" wall insulation	AS 04037	3/8" ID	1.50 \$472.00
	AS 04050	1/2" ID	1.62 \$525.00
	AS 04062	5/8" ID	1.75 \$556.00
	AS 04075	3/4" ID	1.87 \$608.00
	AS 04087	7/8" ID	2.00 \$629.00
	AS 04100	1" ID	2.12 \$676.00
	AS 04112	1 1/8" ID	2.25 \$713.00
	AS 04137	1 3/8" ID	2.50 \$1,154.00
	AS 04162	1 5/8" ID	2.75 \$1,259.00
	AS 04212	2 1/8" ID	3.25 \$1,783.00
AS 04262	2 5/8" ID	3.75 \$2,832.00	
AS 04312	3 1/8" ID	4.25 \$2,937.00	
AS 04362	3 5/8" ID	4.75 \$4,091.00	
AS 04412	4 1/8" ID	5.25 \$5,350.00	

Discount Code F		Per 100 Pieces	
A	B	C	
		Klo-Shure	Overall
		Part No.	ID Dimension
Klo-Shure Clevis Hanger Coupling for 3/4" wall insulation	AS 06025	1/4" ID	1.87 \$608.00
	AS 06037	3/8" ID	2.00 \$650.00
	AS 06050	1/2" ID	2.12 \$671.00
	AS 06062	5/8" ID	2.25 \$713.00
	AS 06075	3/4" ID	2.37 \$1,154.00
	AS 06087	7/8" ID	2.50 \$1,259.00
	AS 06112	1 1/8" ID	2.75 \$1,343.00
	AS 06137	1 3/8" ID	3.00 \$1,720.00
	AS 06162	1 5/8" ID	3.25 \$1,762.00
	AS 06212	2 1/8" ID	3.75 \$2,832.00
AS 06262	2 5/8" ID	4.25 \$2,937.00	
AS 06312	3 1/8" ID	4.75 \$4,091.00	
AS 06362	3 5/8" ID	5.25 \$5,350.00	
AS 06412	4 1/8" ID	5.75 \$8,402.00	
Klo-Shure Clevis Hanger Coupling for 1" wall insulation	AS 08062	5/8" ID	2.75 \$1,259.00
	AS 08087	7/8" ID	3.00 \$1,720.00
	AS 08112	1 1/8" ID	3.75 \$1,762.00
	AS 08137	1 3/8" ID	3.50 \$2,150.00
	AS 08162	1 5/8" ID	3.75 \$2,832.00
	AS 08212	2 1/8" ID	4.25 \$2,937.00
	AS 08262	2 5/8" ID	4.75 \$4,091.00
	AS 08312	3 1/8" ID	5.25 \$5,350.00
	AS 08362	3 5/8" ID	5.75 \$8,402.00

Note: Klo-Shure® ID equals copper tube OD.
 Chart indicates coupling sizes currently available from Klo-Shure®.
 Service Temperature -65°F to 275°F.

SECTION 5 – KLO-SHURE®

KLO-SHURE® STRUT MOUNTED INSULATION COUPLINGS WITH STRUT CLAMP

Klo-Shure® Strut Mounted parts include the Klo-Shure® Coupling, clamp halves with welded fastener and locknut. Used by permission.

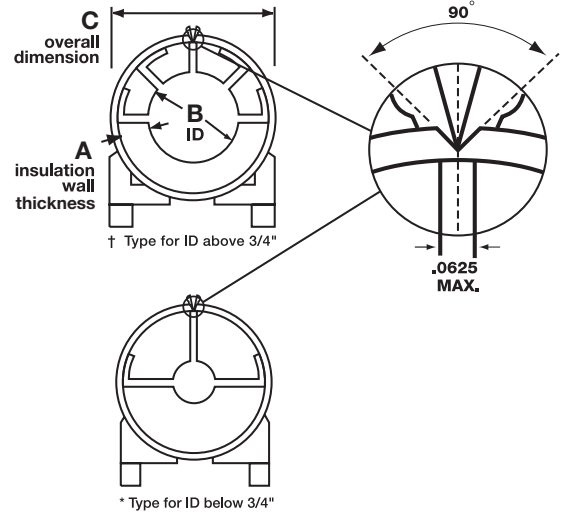
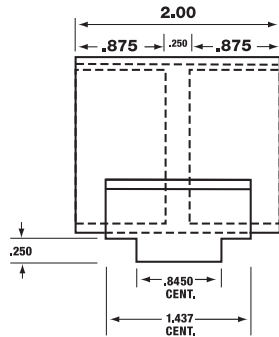

Discount Code F		Per 100 Pieces		
A	B	C		
	Klo-Shure Part No.	Overall ID	Dimension	
Klo-Shure Strut Mounted Coupling for 3/8" wall insulation	AS 23025	1/4" ID	1.12	\$525.00
	AS 23037	3/8" ID	1.25	\$577.00
	AS 23050	1/2" ID	1.37	\$650.00
	AS 23062	5/8" ID	1.50	\$703.00
	AS 23075	3/4" ID	1.62	\$776.00
	AS 23087	7/8" ID	1.75	\$839.00
	AS 23100	1" ID	1.87	\$944.00
	AS 23112	1 1/8" ID	2.00	\$997.00
	AS 23137	1 3/8" ID	2.25	\$1,112.00
	AS 23162	1 5/8" ID	2.50	\$1,553.00
AS 23212	2 1/8" ID	3.00	\$1,762.00	
Klo-Shure Strut Mounted Coupling for 1/2" wall insulation	AS 24037	3/8" ID	1.50	\$703.00
	AS 24050	1/2" ID	1.62	\$776.00
	AS 24062	5/8" ID	1.75	\$839.00
	AS 24075	3/4" ID	1.87	\$944.00
	AS 24087	7/8" ID	2.00	\$997.00
	AS 24100	1" ID	2.12	\$1,049.00
	AS 24112	1 1/8" ID	2.25	\$1,112.00
	AS 24137	1 3/8" ID	2.50	\$1,553.00
	AS 24162	1 5/8" ID	2.75	\$1,678.00
	AS 24212	2 1/8" ID	3.25	\$2,203.00
AS 24262	2 5/8" ID	3.75	\$3,525.00	
AS 24312	3 1/8" ID	4.25	\$3,671.00	
AS 24362	3 5/8" ID	4.75	\$5,140.00	
AS 24412	4 1/8" ID	5.25	\$6,661.00	

Discount Code F		Per 100 Pieces		
A	B	C		
	Klo-Shure Part No.	Overall ID	Dimension	
Klo-Shure Strut Mounted Coupling for 3/4" wall insulation	AS 26025	1/4" ID	1.87	\$944.00
	AS 26037	3/8" ID	2.00	\$997.00
	AS 26050	1/2" ID	2.12	\$1,049.00
	AS 26062	5/8" ID	2.25	\$1,112.00
	AS 26075	3/4" ID	2.37	\$1,332.00
	AS 26087	7/8" ID	2.50	\$1,553.00
	AS 26112	1 1/8" ID	2.75	\$1,678.00
	AS 26137	1 3/8" ID	3.00	\$1,762.00
	AS 26162	1 5/8" ID	3.25	\$2,203.00
	AS 26212	2 1/8" ID	3.75	\$3,525.00
AS 26262	2 5/8" ID	4.25	\$3,671.00	
AS 26312	3 1/8" ID	4.75	\$5,140.00	
AS 26362	3 5/8" ID	5.25	\$6,661.00	
AS 26412	4 1/8" ID	5.75	\$10,647.00	
Klo-Shure Strut Mounted Coupling for 1" wall insulation	AS 28062	5/8" ID	2.75	\$1,678.00
	AS 28087	7/8" ID	3.00	\$1,762.00
	AS 28112	1 1/8" ID	3.75	\$2,203.00
	AS 28137	1 3/8" ID	3.50	\$2,706.00
	AS 28162	1 5/8" ID	3.75	\$3,525.00
	AS 28212	2 1/8" ID	4.25	\$3,619.00
	AS 28262	2 5/8" ID	4.75	\$5,140.00
	AS 28312	3 1/8" ID	5.25	\$6,661.00
	AS 28362	3 5/8" ID	5.75	\$10,647.00

Note: Klo-Shure® ID equals copper tube OD. Chart indicates coupling sizes currently available from Klo-Shure®. Service Temperature -65°F to 275°F.

LEGEND:
GR: Painted Green
EG: Electro-Galvanized

PG: Pre-Galvanized
AL: Aluminum
HG: Hot Dipped Galvanized

PL: Plain
SS: Stainless Steel
ZD: Zinc Dichromate

SECTION 6 – CONCRETE INSERTS

**FIG. 152
 SCREW
 CONCRETE
 INSERT**

Specify Rod Size.
 Size Range 3/8" thru 7/8".



Part No.
Fig. 152 For Prices, See Anvil International Pipe Hanger List Price Sheet.

**FIG. 285
 LIGHT WEIGHT
 CONCRETE INSERT**



Part No.
Fig. 285 For Prices, See Anvil International Pipe Hanger List Price Sheet.

AS 349 CONTINUOUS CONCRETE INSERT

With Closure Strip and End Cap Installed (CS/EC) or
 with Foam and End Cap Installed (F/EC).
 1 5/8" x 1 3/8" x 12 Ga. Channel.

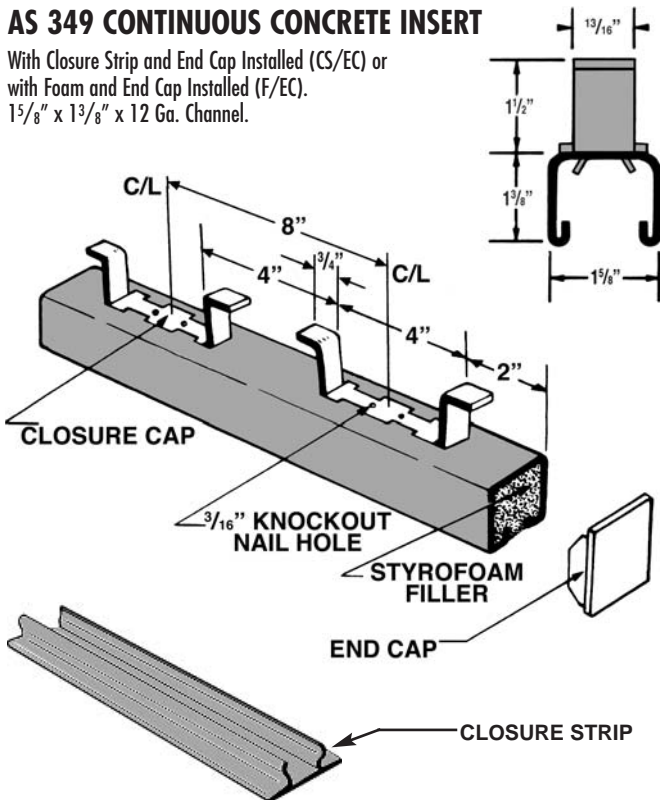

Discount Code E					Per 100 Ft.	
Part No.	End Cap	Std. Pkg.	Wt.	PL	PG	
AS 349 CS/EC 10	A	20	180	\$1,208.59	\$1,362.94	
AS 349 CS/EC 20	A	20	180	\$1,208.59	\$1,362.94	
AS 349 F/EC	A	20	188	\$1,272.19	\$1,316.20	
AS 349 F/EC	A	20	188	\$1,272.19	\$1,316.20	

Load Rating 2000 lbs. Per 12" Section, Based Upon Concrete Compressive Strength of 2500–3000 PSI.

CONCRETE INSERTS

SECTION 6 – CONCRETE INSERTS

AS 349 CONTINUOUS CONCRETE INSERT

Without Closure Strip and End Cap.
1 5/8" x 1 3/8" x 12 Ga. Channel.

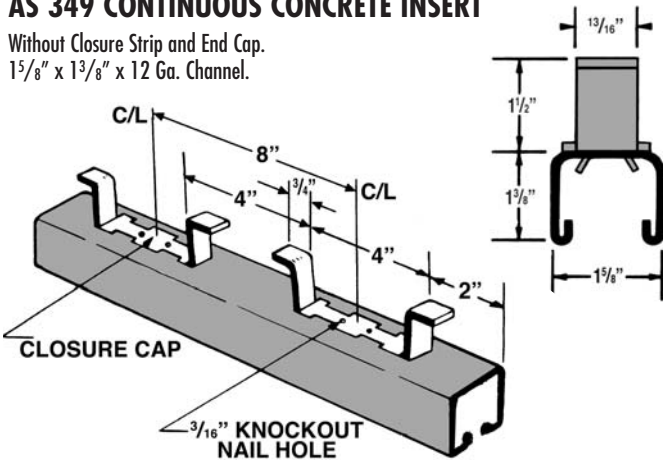

Discount Code E			Per 100 Ft.		
Part No.	Std. Pkg.	Wt.	PL	PG	
AS 349 W/O 10	20	178	\$929.90	\$1,095.01	
AS 349 W/O 20	20	178	\$929.90	\$1,095.01	

Load Rating 2000 lbs. Per 12" Section, Based Upon Concrete Compressive Strength of 2500–3000 PSI.

AS 449 CONTINUOUS CONCRETE INSERT

With Closure Strip and End Cap Installed (CS/EC) or
with Foam and End Cap Installed (F/EC).
1 5/8" x 1 3/8" x 12 Ga. Channel.

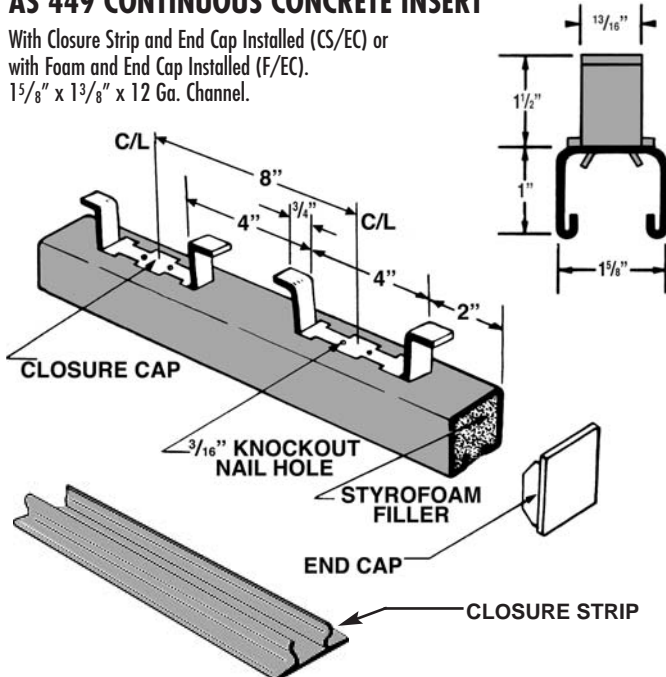

Discount Code E			Per 100 Ft.		
Part No.	End Cap	Std. Pkg.	Wt.	PL	PG
AS 449 CS/EC 10	A	20	152	\$1,072.12	\$1,157.80
AS 449 CS/EC 20	A	20	152	\$1,072.12	\$1,157.80
AS 449 F/EC 10	A	20	162	\$1,118.10	\$1,128.59
AS 449 F/EC 20	A	20	162	\$1,118.10	\$1,128.59

Load Rating 2000 lbs. Per 12" Section, Based Upon Concrete Compressive Strength of 2500–3000 PSI.

AS 449 CONTINUOUS CONCRETE INSERT

Without Closure Strip and End Cap.
1 5/8" x 1" x 12 Ga. Channel.

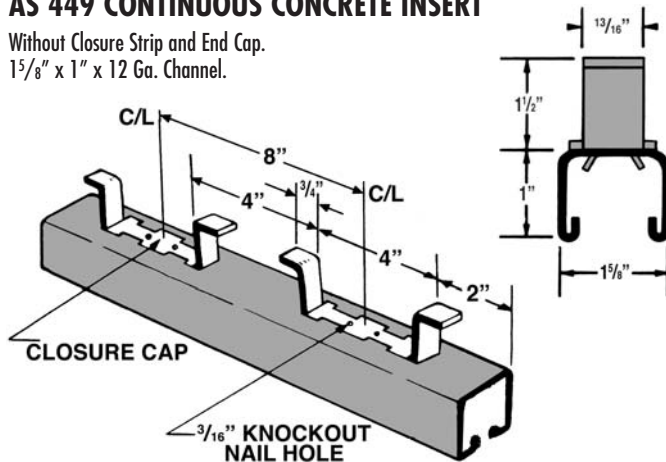

Discount Code E			Per 100 Ft.		
Part No.	Std. Pkg.	Wt.	PL	PG	
AS 449 W/O 10	20	151	\$984.82	\$1,013.59	
AS 449 W/O 20	20	151	\$984.82	\$1,013.59	

Load Rating 2000 lbs. Per 12" Section, Based Upon Concrete Compressive Strength of 2500–3000 PSI.

CONCRETE INSERTS

LEGEND:
GR: Painted Green
EG: Electro-Galvanized

PG: Pre-Galvanized
AL: Aluminum
HG: Hot Dipped Galvanized

PL: Plain
SS: Stainless Steel
ZD: Zinc Dichromate

SECTION 6 – CONCRETE INSERTS

**AS 653
 TYPE "B"
 END CAP**

Use With AS 349 Insert.

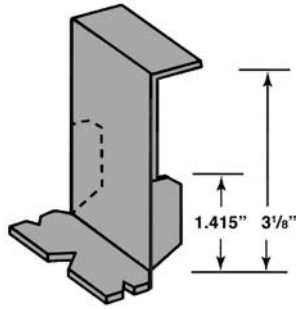

Discount Code D		Per 100 Pieces	
Part No.	Std. Pkg.	Wt.	PG
AS 653	100	14	\$247.99

This item sold only in full box quantities.

**AS 654
 TYPE "B"
 END CAP**

Use With AS 449 Insert.

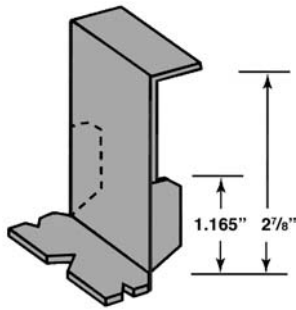

Discount Code D		Per 100 Pieces	
Part No.	Std. Pkg.	Wt.	PG
AS 654	50	12	\$284.99

This item sold only in full box quantities.

**FIG. 284
 CONCRETE
 DECK INSERT**

Size Range 3/8" thru 5/8".



Part No.
Fig. 284

For Prices, See Anvil International Pipe Hanger List Price Sheet.

**AS 6151
 PLASTIC
 CLOSURE
 STRIP**

Use With All Continuous Inserts 10 Ft. Length.

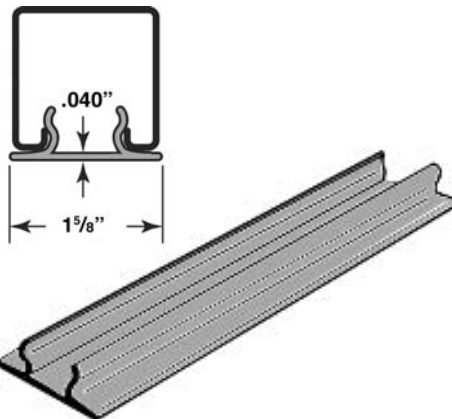

Discount Code A		Per 100 Ft.	
Part No.	Std. Pkg.	Wt.	PL
AS 6151 10	100	47	\$770.98

CONCRETE INSERTS

TECHNICAL DATA

NOTE: Anvil Strut Rollers Consist of Cast Iron Roller & Steel Bracket.

AS 815 (6" TO 18" PIPE) DOUBLE ROLLER PIPE SUPPORT

Order Nuts and Bolts Separately.

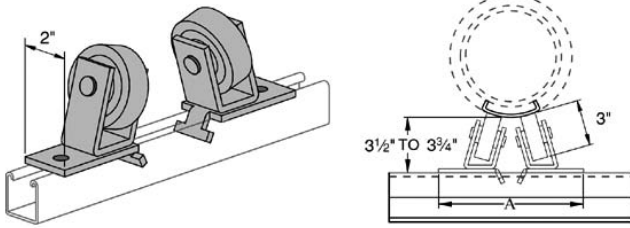

Chart for Dimension A

Pipe Size	No Insulation	1"	1 1/2"	2"	2 1/2"	3"	4"
6"	9 1/2"	10 1/4"	10 1/2"	10 3/4"	11"	11 3/8"	11 7/8"
8"	10 1/8"		11"	11 3/8"	11 3/4"	12"	12 1/2"
10"	10 3/4"		11 5/8"	12"	12 1/4"	12 1/2"	13"
12"	11 1/4"		12 1/8"	12 1/2"	12 3/4"	13"	13 1/2"
14"	11 5/8"		12 1/2"	12 7/8"	13"	13 3/8"	14"
16"	12 1/8"		13"	13 3/8"	13 7/8"	14"	14 1/2"

AS 1901 (1" - 8" PIPE) PIPE ROLLER SUPPORT

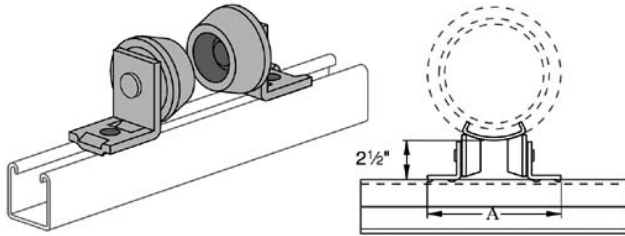

Chart for Dimension A

Pipe Size	No Insulation	1"	1 1/2"	2"	2 1/2"	3"	4"
1/2"	6 1/2"	6 1/2"					
3/4"	6 1/2"	6 1/2"	6 5/8"	6 7/8"			
1"	6 1/2"	6 1/2"	6 5/8"	6 7/8"			
1 1/4"	6 1/2"	6 1/2"	6 7/8"	7 1/8"	7 3/8"		
1 1/2"	6 1/2"	6 1/2"	6 7/8"	7 1/8"	7 3/8"		
2"	6 1/2"	6 5/8"	7 1/8"	7 3/8"	7 1/2"	8"	
2 1/2"	6 1/2"	6 5/8"	7 1/8"	7 3/8"	7 1/2"	8"	
3"	6 1/2"	7"	7 1/2"	7 3/4"	7 7/8"	8 1/8"	
3 1/2"	6 1/2"	7"	7 1/2"	7 3/4"	7 7/8"	8 1/8"	
4"	6 5/8"	7 1/4"	7 5/8"	7 7/8"	8"	8 3/8"	9"

AS 1902 PIPE ROLLER SUPPORT

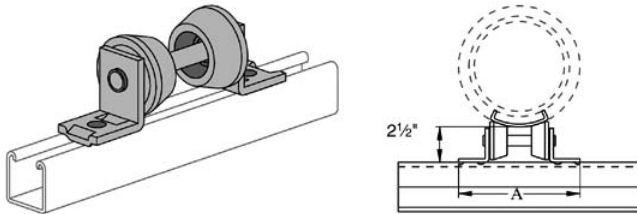

Chart for Dimension A

Pipe Size	No Insulation	1"	1 1/2"	2"	2 1/2"	3"	4"
1/2"	AS 1902-1"-2"	AS 1902-1"-2"	AS 1902-1"-2"	AS 1902-2 1/2"-3 1/2"			
3/4"	AS 1902-1"-2"	AS 1902-1"-2"	AS 1902-1"-2"	AS 1902-2 1/2"-3 1/2"			
1"	AS 1902-1"-2"	AS 1902-1"-2"	AS 1902-1"-2"	AS 1902-2 1/2"-3 1/2"			
1 1/4"	AS 1902-1"-2"	AS 1902-1"-2"	AS 1902-1"-2"	AS 1902-2 1/2"-3 1/2"			
1 1/2"	AS 1902-1"-2"	AS 1902-1"-2"	AS 1902-2 1/2"-3 1/2"	AS 1902-2 1/2"-3 1/2"	AS 1902-2 1/2"-3 1/2"		
2"	AS 1902-1"-2"	AS 1902-1"-2"	AS 1902-2 1/2"-3 1/2"	AS 1902-2 1/2"-3 1/2"	AS 1902-2 1/2"-3 1/2"	AS 1902-2 1/2"-3 1/2"	
2 1/2"	AS 1902-1"-2"	AS 1902-1"-2"	AS 1902-2 1/2"-3 1/2"	AS 1902-2 1/2"-3 1/2"	AS 1902-2 1/2"-3 1/2"	AS 1902-2 1/2"-3 1/2"	
3"	AS 1902-1"-2"	AS 1902-2 1/2"-3 1/2"	AS 1902-2 1/2"-3 1/2"	AS 1902-4"-6"	AS 1902-4"-6"	AS 1902-4"-6"	
3 1/2"	AS 1902-1"-2"	AS 1902-2 1/2"-3 1/2"	AS 1902-2 1/2"-3 1/2"	AS 1902-4"-6"	AS 1902-4"-6"	AS 1902-4"-6"	
4"	AS 1902-1"-2"	AS 1902-2 1/2"-3 1/2"	AS 1902-2 1/2"-3 1/2"	AS 1902-4"-6"	AS 1902-4"-6"	AS 1902-4"-6"	
5"	AS 1902-2 1/2"-3 1/2"	AS 1902-4"-6"	AS 1902-4"-6"	AS 1902-4"-6"	AS 1902-4"-6"	AS 1902-8"	AS 1902-8"
6"	AS 1902-2 1/2"-3 1/2"	AS 1902-4"-6"	AS 1902-4"-6"	AS 1902-4"-6"	AS 1902-4"-6"	AS 1902-8"	AS 1902-8"
8"	AS 1902-2 1/2"-3 1/2"	AS 1902-4"-6"	AS 1902-8"	AS 1902-8"	AS 1902-8"	AS 1902-8"	AS 1902-8"

AS 1911 PIPE ROLLER

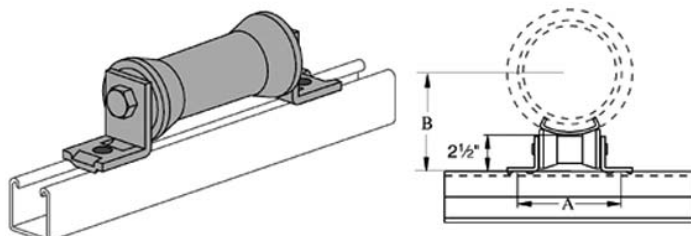

Chart for Dimension A

Size	Fit Pipe Size	A	B
2" - 3 1/2"	2"	5"	3"
	2 1/2"	5"	3 1/4"
	3"	5"	3 5/8"
4" - 6"	3 1/2"	5"	3 7/8"
	4"	5 7/8"	4 5/16"
	5"	5 7/8"	4 7/8"
8" - 10"	6"	5 7/8"	5 1/16"
	8"	8 5/16"	7 1/8"
	10"	8 5/16"	8 1/4"
12" - 14"	12"	10 7/8"	9 7/8"
	14"	10 7/8"	10 1/2"

TECHNICAL DATA

ANVIL-STRUT™ TECHNICAL DATA

The Anvil-Strut™ Metal Framing System offers a unique and flexible series of metal channels and fittings designed to fill a wide variety of construction requirements, from supporting sprinkler systems, electrical conduit or any other piping system, to the erection of mezzanines, walkways, or guardrails. Anvil-Strut™ has also demonstrated its usefulness in a multitude of OEM applications, including such products as scaffolding, conveyors, electronic enclosures, and truck body parts just to name a few.

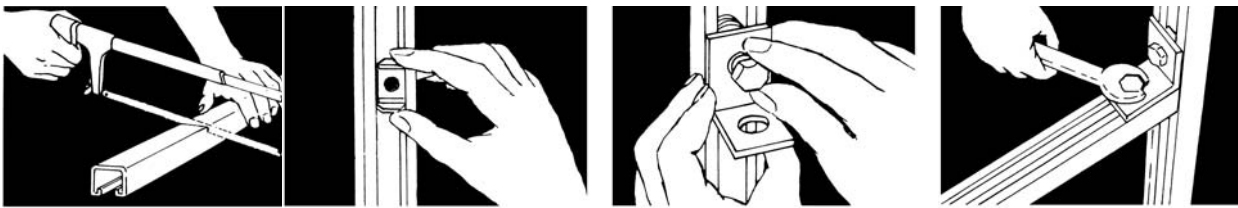

A Saw, A Wrench, and Anvil-Strut™

The Anvil-Strut™ Metal Framing System provides a continuous support system that is fully adjustable, completely reusable and comes with the added benefit of many time-saving features. That translates into a system that is strong, fast, and economical with no welding or drilling. From planning to actual construction, your job will proceed smoothly in less time and with less effort.

With the Anvil-Strut™ channel and fittings, lightweight suspension systems can be quickly erected in an unlimited variety of styles, to meet all your structural requirements, providing a firm anchorage for any type of pipe hanger or support application. In situations using poured concrete construction, Anvil-Strut™ concrete insert channel provides a continuous, flush mounting slot in floors, walls or ceilings.

Fabrication with Anvil-Strut™ is simple and fast. First cut the strut channel to the desired length with a hacksaw, chop saw, or powered band saw. Next insert the special grip nut with integrated retaining spring into the channel slot and turn 90 degrees to align the nut grooves with the channel lips. The nut may be slid to any desired location along the entire length of the channel allowing total adjustability.

Depending on the style of assembly being made, the appropriate fitting is then positioned over the nut and a cap screw is inserted. Finally the screw is tightened using an ordinary wrench, causing the serrated teeth in the grip nut to bite into the channel lips, positively locking the components into a rigid assembly. **NO DRILLING...NO WELDING...NO SPECIAL TOOLS.**

This catalog is not intended to show the complete Anvil-Strut™ line of fittings and accessories, but rather to illustrate the most commonly used items. Literally hundreds of additional items are available, most from stock, to meet your requirements.

Our engineering department will be happy to assist you in incorporating Anvil-Strut™ into your next project. Our recommendations will be provided to you without obligation.

TECHNICAL DATA

Materials

CARBON STEEL

Channels are formed from high-quality, structural grade carbon steel which has been manufactured in accordance with ASTM A-570 specification Grade 33 (hot rolled), or ASTM 366 (cold rolled), with mechanical properties of 33 ksi minimum yield and 52 ksi minimum tensile strength. The precision roll-forming process by which the channels are formed "cold works" the steel, thereby increasing its mechanical properties.

STAINLESS STEEL

Channels are formed from chromium-nickel stainless steel sheet manufactured in accordance with ASTM A-240 specification, offered in both AISI Type 304 and 316 material to provide protection in varying corrosive conditions.

ALUMINUM

Extruded aluminum channel is produced from 6063-T6 alloy, and fittings are produced from 5052-H32 alloy, both in accordance with ASTM B-221 specifications. Aluminum is suitable for use in various corrosive environments.

Finishes

PRE-GALVANIZED

Hot dip, mill galvanized coating produced through a process of continuously passing the steel through a bath of molten zinc. This process is performed in accordance with ASTM A-653. The thickness of the zinc coating conforms with ASTM G90 which represents a coating thickness of .90 ounces of zinc per square foot (.45 per side). This coating is applied to the steel master coils prior to slitting and fabrication.

HOT DIP GALVANIZED - POST FABRICATION

The finished channel is completely immersed in a bath of molten zinc, resulting in the complete coating of all surfaces of the product, including edges and welds. Strut channels that are hot dip galvanized, have a total coating weight of 3.0 ounces of zinc per square foot (1.5 ounces per side) in accordance with ASTM A-123 specification. This coating provides superior results in applications calling for prolonged outdoor exposure.

SUPR-GREEN POWDER COATING

Strut channels are coated after fabrication with polyester powder finish. This coating is applied using an electrostatic spray process, beginning with cleaning and phosphating, through a bonderite pre-treatment process, and ending with oven curing. The resulting finish provides a high quality appearance and durability.

ZINC DICHROMATE

The finished channel undergoes a multi-step process consisting of electrogalvanizing, in accordance with ASTM B-633-85, followed by an application of zinc dichromate, which provides the distinctive gold coloration of the finish. All surfaces are coated because the process is performed after fabrication.

PVC

A corrosive resistant PVC (polyvinyl chloride) coating is applied over the completed strut channel. The coating process consists of surface pretreatment, followed by preheating of the part, which is then passed through a fluidized bed of vinyl plastic powder. The powder melts onto the heated channel forming a smooth coating which undergoes a final heat curing.

TECHNICAL DATA

Life of Protection vs. Thickness of Zinc and Type of Atmosphere

Life of Protection vs. Thickness of Zinc and Type of Atmospheres

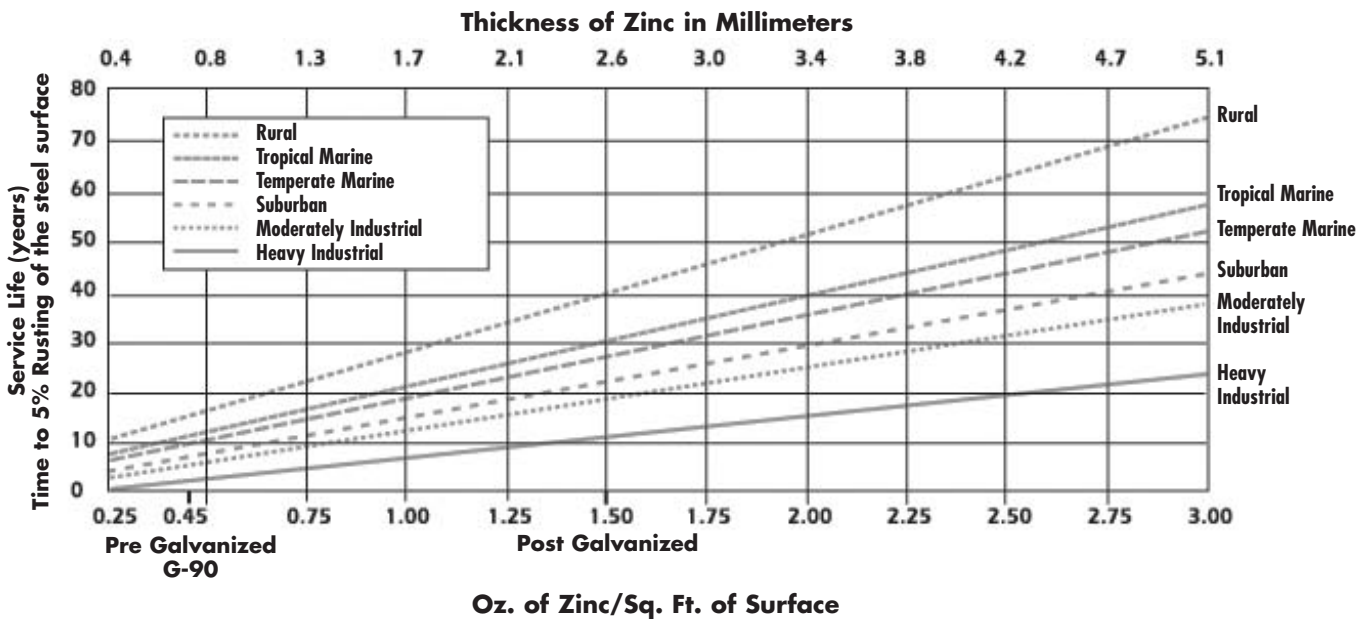

The chart above represents the expected life of Anvil-Strut™ when exposed to various atmospheres, ranging from moderate to severe. This chart is helpful for the designer when selecting which galvanized coating is best suited for the given application. It has been compiled from many years of service in the various industries Anvil serves.

Anvil's outstanding quality control procedures assure the end user each piece of Anvil-Strut™ has been manufactured to the most rigid specifications in the industry, and will provide the level of field service you have come to expect from Anvil International.

Should you have a custom application that requires additional information, our engineering department is ready to review it.

TECHNICAL DATA

Pipe Clamps

SPECIFICATIONS

GENERAL

Anvil-Strut™ Pipe Clamps are all manufactured to fit into the standard openings of 1⁵/₈" channel to support runs of piping where desired, to secure the pipe in place.

MATERIAL

Anvil-Strut™ pipe clamps are manufactured from the following materials:

- Hot Rolled Steel Sheet (ASTM-A-569)
- Cold Rolled Steel Sheet (ASTM-A-366)
- Stainless Steel - Type 304/316 (ASTM-A-240)

FINISH

Anvil-Strut™ pipe clamps are available in the following finishes:

- Electro Galvanized (ASTM-B-633BSCI)
- Hot Dipped Galvanized (ASTM-A-123)
- Copper Plated
- Zinc Dichromate

ORDERING

Please specify catalog number, size and finish.

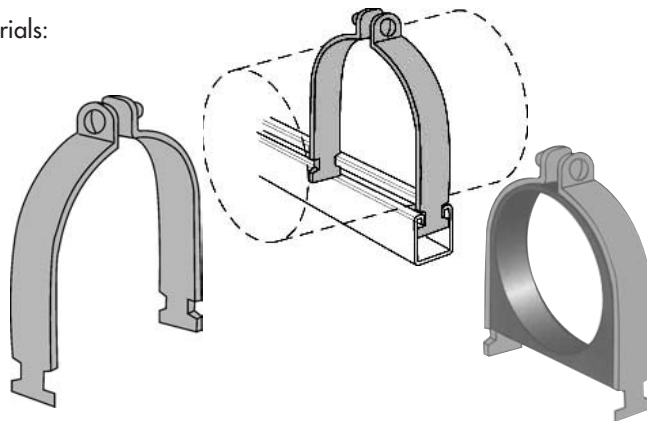

Concrete Inserts & Accessories

SPECIFICATIONS

GENERAL

Anvil-Strut™ Concrete Inserts are designed for the attachment or suspension of framing, piping or equipment to concrete structures where a continuous insert slot is required. Continuous Concrete Inserts are nailed to the forms through the knockout holes provided in the closure cap. Nails may be cut off after removal of the forms.

MATERIAL

Anvil-Strut™ Concrete Inserts and Accessories are produced from prime steel covering the following specifications:

- Cold Rolled Carbon Steel (ASTM-A-366)
- Hot Rolled Carbon Steel (ASTM-570)
- Stainless Steel - Type 304/316 (ASTM-A-240)

FINISH

Anvil-Strut™ Concrete Inserts and Accessories are stocked in the following finishes:

- Pre Galvanized (ASTM-A-525-G90)
- Electro Galvanized (ASTM-B-633BSC)

LENGTH

Anvil-Strut™ Concrete Inserts are produced and stocked in 10 and 20 foot lengths. Other lengths are available upon request.

ORDERING

Specify catalog number, length or size where required and finish when necessary.

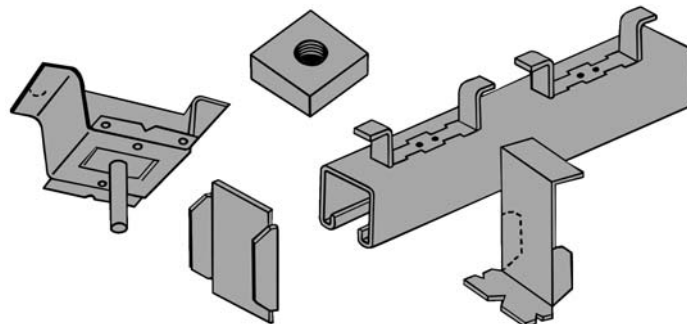

TECHNICAL DATA

General Fittings

SPECIFICATIONS

GENERAL

Anvil-Strut™ General Fittings are designed to fit with all Anvil-Strut™ 1 5/8" wide channels. All Anvil-Strut™ fittings are manufactured from 1/4" thick carbon steel, 1 5/8" wide, all holes are 9/16" diameter, spaced 1 7/8" on center and 1 3/16" from the end.

The more popular fittings are illustrated on the previous pages. However, there are hundreds of other fittings available. Please contact the factory for any other fittings you may need for specific applications.

MATERIAL

Anvil-Strut™ fittings are manufactured from the following material:

- Hot Rolled Steel Sheet (ASTM-A-569)
- Cold Rolled Steel Sheet (ASTM-A-366)
- Stainless Steel - Type 304/316 (ASTM-A-240)

ORDERING

Please specify catalog number and finish.

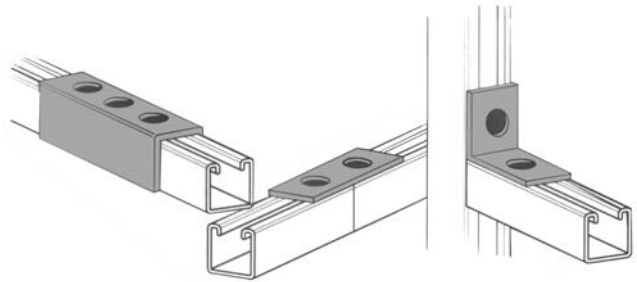

Design Load Data

(For typical channel-fitting connections when USED IN PAIRS.)

90° Fitting			90° Fitting			90° Fitting			90° Fitting			90° Fitting			90° Fitting		
Channel Thickness			Channel Thickness			Channel Thickness			Channel Thickness			Channel Thickness			Channel Thickness		
12 ga.	14 ga.	16 ga.	12 ga.	14 ga.	16 ga.	12 ga.	14 ga.	16 ga.	12 ga.	14 ga.	16 ga.	12 ga.	14 ga.	16 ga.	12 ga.	14 ga.	16 ga.
(2.6)	(1.9)	(1.5)	(2.6)	(1.9)	(1.5)	(2.6)	(1.9)	(1.5)	(2.6)	(1.9)	(1.5)	(2.6)	(1.9)	(1.5)	(2.6)	(1.9)	(1.5)
Lbs. 1500	1000	750	Lbs. 1000	650	500	Lbs. 2000	1500	900	Lbs. 1500	1150	650	Lbs. 1500	1000	1000	Lbs. 1000	650	500
kN (6.67)	(4.45)	(3.34)	kN (4.45)	(2.89)	(2.22)	kN (8.90)	(6.67)	(4.00)	kN (6.67)	(5.12)	(2.89)	kN (6.67)	(4.45)	(4.45)	kN (4.45)	(2.89)	(2.22)

Design load data includes a safety factor of 2.5 (safety factor = ratio of ultimate load to design load).

90° Fitting			90° Fitting			90° Fitting			90° Fitting			Flat Fitting			Flat Fitting		
Channel Thickness			Channel Thickness			Channel Thickness			Channel Thickness			Channel Thickness			Channel Thickness		
12 ga.	14 ga.	16 ga.	12 ga.	14 ga.	16 ga.	12 ga.	14 ga.	16 ga.	12 ga.	14 ga.	16 ga.	12 ga.	14 ga.	16 ga.	12 ga.	14 ga.	16 ga.
(2.6)	(1.9)	(1.5)	(2.6)	(1.9)	(1.5)	(2.6)	(1.9)	(1.5)	(2.6)	(1.9)	(1.5)	(2.6)	(1.9)	(1.5)	(2.6)	(1.9)	(1.5)
Lbs. 2500	2000	1500	Lbs. 2000	1650	1250	Lbs. 3000	2000	1500	Lbs. 2500	1650	1250	Lbs. 1000	800	600	Lbs. 1000	800	600
kN (11.12)	(8.90)	(6.67)	kN (8.90)	(7.34)	(5.56)	kN (13.34)	(8.90)	(6.67)	kN (11.12)	(7.34)	(5.56)	kN (4.45)	(3.56)	(2.67)	kN (4.45)	(3.56)	(2.67)

TECHNICAL DATA

TECHNICAL DATA

Fundamentals of Design

BEAMS

Beams are members which are subjected to loads at right angles (perpendicular) to their length. Most commonly, beams are horizontal and are therefore subjected to vertical loads usually related to gravity, i.e. - a shelf, platform or support for pipe or conduit. Loads cause beams to bend, called deflection. The ultimate consideration when designing a beam structure is whether or not it is strong enough. In other words, will it hold the anticipated load and provide a safety factor for unanticipated loads or other variations in conditions. A beam's ability to support a load is determined by its allowable bending moment and resulting amount of deflection. This load carrying ability is dependent on a number of factors: the amount of load, the type of load, the manner in which the beam is supported and the stiffness of the beam (a function of the beam's shape and the material from which it is made).

Types of Beam Loading

Point Load - A point load is concentrated at a single point along the beam's span (in reality, the load is concentrated over a very small length of the beam).

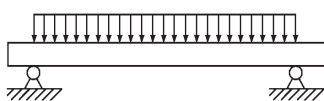
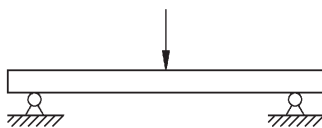

Uniform Load - A uniform load is spread evenly over the length of the beam from support to support.

Types of Beam Support Conditions

Simple Beam - A simple beam is supported at both ends by non-fixed connections which prevent vertical movement at the support point, but allow the beam to rotate or flex into a normal deflected shape. The majority of bolted metal framing connections closely approximate these conditions. The loading data presented in this catalog is based on simple beam analysis unless otherwise noted.

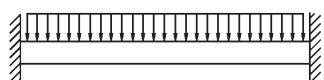
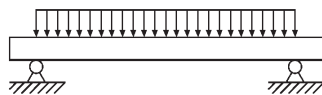

Fixed Beam - A fixed beam has rigid connections at each end that restrict the rotation of the beam and resist its deflection. The increased stiffness provided by this resistance to rotation provides a greater load capacity than that of an

equivalent simple beam. A fixed-end beam would result when a channel span is welded to rigid upright supports.

Continuous Beam - A continuous beam rests on more than two supports. The outside spans of a continuous beam will act like simple beams, while the interior spans will behave in a manner similar to fixed beams.

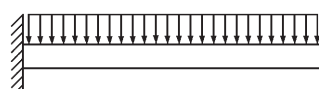
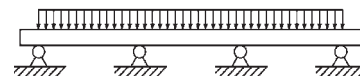

Cantilever Beams - A cantilever beam is supported by a fixed, rigid connection at one end and is totally unsupported at the opposite end. Shelf brackets and many of the strut brackets shown in this catalog are examples of cantilever beams.

Loading and Deflection

All beams will deflect or "sag" when a load is applied. The magnitude of the deflection is dependent on the following factors:

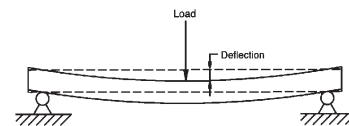

- The amount of load plus the weight of the beam itself.
- The manner in which the load is distributed.
- The method by which the beam is supported.
- The cross sectional shape of the beam.
- The material from which the beam is made.

The stiffness of the beam derived from its cross sectional shape is defined by its "Moment of Inertia" or "I". The greater the "I" value of a beam, the greater its stiffness and the smaller its deflection. "I" values are given for both major axis (X-X and Y-Y). Increasing the height of the strut channel (Y-Y axis) is a straightforward way to increase its stiffness and lower its deflection.

The stiffness of a beam derived from its material composition is defined by its "Modulus of Elasticity" or "E". The greater the "E" value of the beam's material, the stiffer it is, and the smaller the deflection. A material's elasticity does not necessarily relate to its strength but rather its deflection under a given load.

The beam capacities in this catalog include the weight of the beam itself. Therefore, the strut beam weight must be subtracted from the loading capacities given to provide the net beam capacity.

TECHNICAL DATA

Design of Anvil-Strut™ Systems

Safety Factor, Stress and Bending Moment

The most important design consideration is the determination of adequate load bearing capacity. The beam must support its own weight, plus the weight of anticipated loads, and in addition, have enough capacity to safely handle unanticipated loads and variations in other relevant conditions. This "safety factor" is usually established by various design codes and standards. One method of measuring a beams capacity is the allowable stress method whereby the beams maximum allowable stress is determined in pounds per square inch (psi).

The maximum allowable uniform loads (and corresponding deflections) presented in this catalog for strut channel beam loads are based on a simple beam configuration utilizing an allowable stress of 25,000 psi. This maximum allowable stress provides a theoretical safety factor of 1.68 which is derived from carbon steel's minimum yield strength of 33,000 psi, which is increased to 42,000 psi as a result of the steel being cold worked in the rolling process. In addition, the data given in this catalog under maximum allowable uniform loads is consistent with the current AISI "Specification For the Design of Cold-Formed Steel Structural Members". The bending moment divided by a beam's sectional modulus "S" equals stress.

As mentioned above, all beams will deflect or sag under load. It is worth noting that noticeable sagging is not an indication of an incorrectly designed beam installation. There may be situations however where it is desirable to address the visual appearance of an installation by minimizing deflection. In most applications a deflection equating to 1/240 of the span's length will provide an acceptable appearance. The tables presented in this catalog show loading at 1/240 deflections, as well as loading at 1/360 deflections that can be used in situations which have highly demanding visual requirements.

Columns

Columns are structural members that support compression loads (loads that are parallel to the length of the column). While most often vertical, any structural member that is loaded in compression, such as a diagonal brace, is considered a column.

Allowable column loading is dependent on a number of factors:

- (a) Column length - Column length is the distance between brace points.

- (b) Concentric vs eccentric loading - Concentric loading is a load applied upon the cross-sectional center of gravity, such as a load which rests on the top of a column. An eccentric load is any load which is not concentric. A fitting bolted to a strut channel slot will impart an eccentric load to the channel. The data presented in this catalog assumes concentric loading.
- (c) Support conditions - The column end support condition is mathematically represented by its "K-factor". A pinned connection is one that prevents lateral movement, but allows rotation. A fixed connection provides restraint against both lateral movement and rotation. A free top connection is one that is restrained against rotation but is free to move laterally. The data presented in this catalog assumes a pinned top/pinned bottom condition ("K" equals 1.0).
- (d) Cross-sectional shape - The column's cross-sectional shape is represented by its "Radius of Gyration" or "r" value. The axis with the smaller "r" value should be used for design evaluation.

In accordance with AISI "Specification for the Design of Cold Formed Steel Structural Members", column load data shown in this catalog is based on 33,000 psi yield strength. The data takes into account the effect of torsional and/or torsional-flexural buckling. Where possible, columns should be braced to minimize these effects.

Bolt Torque









Recommended bolt torque values are given below. These torque values are suggested as a guideline to assist in arriving at the proper bolt tension. It should be kept in mind that the relationship between wrench torque and bolt tension is not always consistent. Factors effecting this relationship include metal finish and the presence or lack of a lubricant. Lubricated threads will increase the bolt tension for a given amount torque applied, and could potentially result in over torquing. The values shown here assume a properly calibrated torque wrench and clean, non-lubricated bolt, nut, washer and fitting.

BOLT SIZE	¼ - 20	⅜ - 18	½ - 16	⅝ - 13
FOOT-LBS	6	11	19	50

TECHNICAL DATA

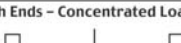
Anvil-Strut™ Beam Loading Formulas

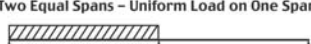
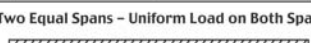
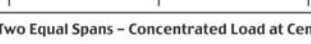
For determining beam load other than simple beam load (supported at both ends), use the appropriate factor from the chart below and multiply by data provided on the appropriate channel page.

LOAD AND SUPPORT CONDITION	LOAD FACTOR	DEFLECTION FACTOR
Simple Beam - Uniform Load 	1.00	1.00
Simple Beam - Concentrated Load at Center 	.50	.80
Simple Beam - Two Equal Concentrated Loads at 1/4 Points 	1.00	1.10
Beam Fixed at Both Ends - Uniform Load 	1.50	.30
Beam Fixed at Both Ends - Concentrated Load at Center 	1.00	.40
Cantilever Beam - Uniform Load 	.25	2.40
Cantilever Beam - Concentrated Load at End 	.12	3.20
Continuous Beam - Two Equal Spans - Uniform Load on One Span 	1.30	.92
Continuous Beam - Two Equal Spans - Uniform Load on Both Spans 	1.00	.42
Continuous Beam - Two Equal Spans - Concentrated Load at Center of One Span 	.62	.71
Continuous Beam - Two Equal Spans - Concentrated Load at Center of Both Spans 	.67	.48

EXAMPLES:

PROBLEM:
Calculate the load and corresponding deflection of the AS 200 beam continuous over one support and loaded uniformly on one span.

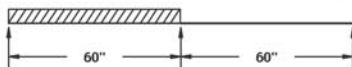

SOLUTION:
From the load table for AS 200, for a 60" span, the maximum allowable load is 650 lbs. and the corresponding deflection is .344". Multiplying by the appropriate factors shown in the chart above:

LOAD = 650 lbs. x 1.3 = 845 lbs.
DEFLECTION = .344" x .92 = .316"

PROBLEM:
Calculate the load and corresponding deflection of a cantilever AS 150 beam with a concentrated load on the end.

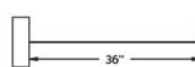

SOLUTION:
From beam load chart for AS 150, for a 36" span, the maximum allowable load is 2101 lbs. and the corresponding deflection is .085". Multiplying by the appropriate factors shown in the chart above:

LOAD = 2102 lbs. x .12 = 252 lbs.
DEFLECTION = .085" x 3.20 = .272"

TECHNICAL DATA

Common Beam Loading Formulas

SIMPLE BEAMS

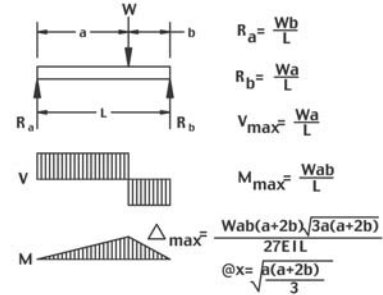
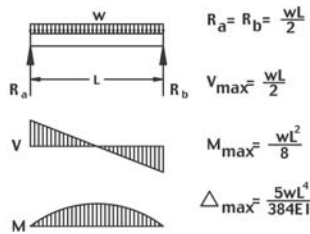
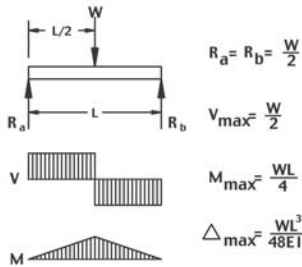

BEAM FIXED AT ONE END, SUPPORTED AT OTHER

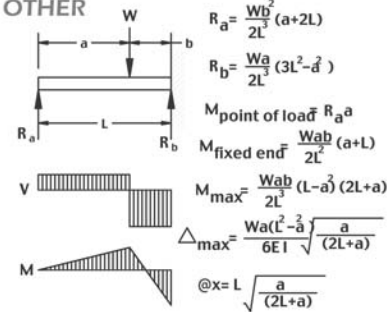
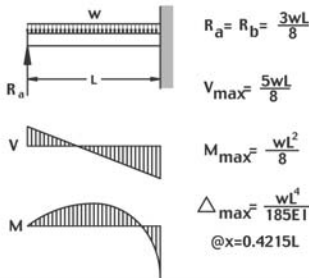
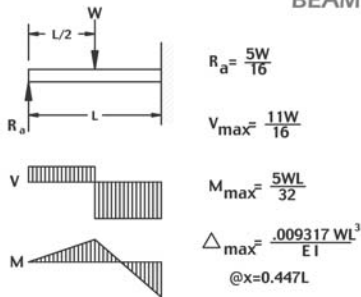

BEAM FIXED AT BOTH ENDS

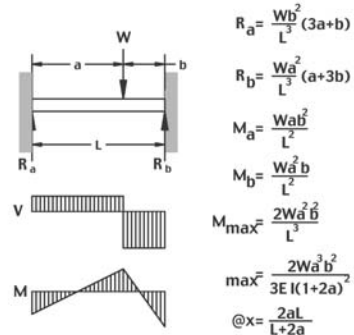
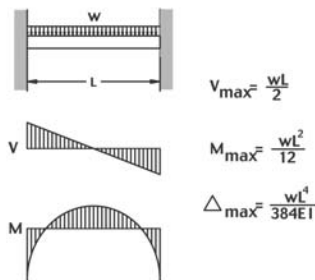
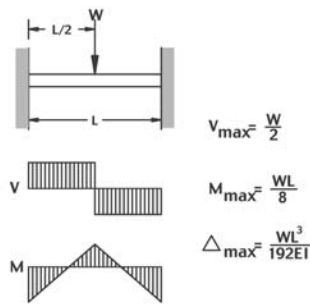

CANTILEVER BEAMS

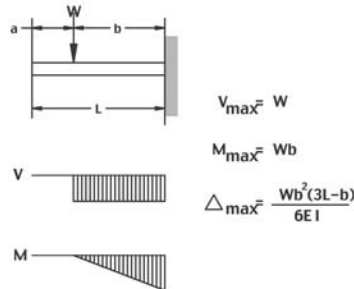
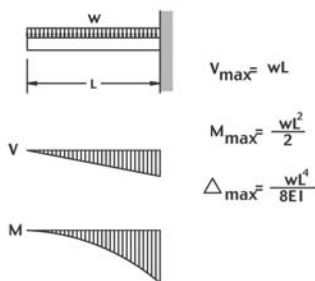
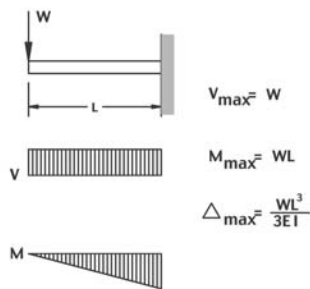

R - Reaction
M - Moment
W - Concentrated Load

w - Uniform Load (Weight/Unit Length)
V - Shear
L - Length

Δ - Deflection
E - Modulus of Elasticity
I - Moment of Inertia

TECHNICAL DATA

Electrical Metallic Tubing Data

Nom. Size EMT Conduit	OD Conduit	Conduit Wt. lbs./ft.	Approx. Max. Wt. (lbs./ft.) Conduit and Conductor Not Lead Covered
1/2	0.706	0.29	0.54
3/4	0.922	0.45	1.16
1	1.163	0.65	1.83
1 1/4	1.510	0.96	2.96
1 1/2	1.740	1.11	3.68
2	2.197	1.41	4.45
2 1/2	2.875	2.15	6.41
3	3.500	2.60	9.30
3 1/2	4.000	3.25	12.15
4	4.500	3.90	15.40

Application Engineering Data - Conduit Spacings



Spacings in inches between centers of conduits. The light face figures are the minimum dimensions to provide clearance between locknuts. The more liberal spacings printed in bold face type should be used whenever possible.



Size	Size												
	1/2"	3/4"	1"	1 1/4"	1 1/2"	2"	2 1/2"	3"	3 1/2"	4"	4 1/2"	5"	6"
1/2"	1 3/16 1 3/8	—	—	—	—	—	—	—	—	—	—	—	—
3/4"	1 5/16 1 1/2	1 7/16 1 5/8	—	—	—	—	—	—	—	—	—	—	—
1"	1 1/2 1 3/4	1 5/8 1 7/8	1 3/4 2	—	—	—	—	—	—	—	—	—	—
1 1/4"	1 3/4 2	1 7/8 1 5/8	2 2 1/4	2 1/4 2 1/2	—	—	—	—	—	—	—	—	—
1 1/2"	1 15/16 2 1/8	2 1/16 2 1/4	2 3/16 2 3/8	2 7/16 2 5/8	2 9/16 2 3/4	—	—	—	—	—	—	—	—
2"	2 3/16 2 3/8	2 5/16 2 1/2	2 1/2 2 3/4	2 3/4 3	2 7/8 3 1/8	3 1/8 3 3/8	—	—	—	—	—	—	—
2 1/2"	2 7/16 2 5/8	2 9/16 2 3/4	2 3/4 3	3 3 1/4	3 1/8 3 3/8	3 3/8 3 5/8	3 5/8 4	—	—	—	—	—	—
3"	2 13/16 3	2 15/16 3 1/8	3 1/16 3 3/8	3 5/16 3 5/8	3 7/16 3 3/4	3 3/4 4	4 4 3/8	4 5/16 4 1/4	—	—	—	—	—
3 1/2"	3 1/8 3 3/8	3 1/4 3 1/2	3 3/8 3 5/8	3 5/8 3 7/8	3 3/4 4	4 1/16 4 3/8	4 5/16 4 5/8	4 5/8 5	4 15/16 5 3/8	—	—	—	—
4"	3 7/16 3 3/4	3 9/16 3 7/8	3 11/16 4	3 15/16 4 1/4	4 1/16 4 3/8	4 3/8 4 3/4	4 5/8 5	4 5/8 5 3/8	4 15/16 5 5/8	5 1/4 5 5/8	5 9/16 6	—	—
4 1/2"	3 3/4 4	3 7/8 4 1/8	4 4 1/4	4 1/4 4 1/2	4 5/8 4 3/4	4 5/8 5	4 7/8 5 1/4	4 7/8 5 1/4	5 1/4 5 5/8	5 9/16 6	5 7/8 6 1/4	6 1/8 6 1/2	—
5"	4 1/8 4 3/8	4 1/4 4 1/2	4 3/8 4 5/8	4 5/8 4 7/8	4 3/4 5	5 5 3/8	5 1/4 5 5/8	5 9/16 6	5 7/8 6 1/4	6 3/16 6 5/8	6 1/2 7	6 13/16 7 1/4	—
6"	4 3/4 5	4 7/8 5 1/8	5 5 1/4	5 1/4 5 1/2	5 3/8 5 5/8	5 5/8 6	5 7/8 6 1/4	6 3/16 6 5/8	6 1/2 7	6 13/16 7 1/4	7 1/8 7 5/8	7 7/16 8	8 1/8 8 5/8

TECHNICAL DATA

Minimum Size Anvil-Strut Channel

(To Comply with NFPA 13 Table 2-6.1 5(a) 1996 Edition)

Channel Size	Section Mod. (in. ³)
 AS-200 1 5/8" x 1 5/8" x 12 ga.	.202
 AS-150 1 5/8" x 2 7/16" x 12 ga.	.391
 AS-100 1 5/8" x 3 1/4" x 12 ga.	.628

Channel Size	Section Mod. (in. ³)
 AS-150 BTB 1 5/8" x 4 7/8" x 12 ga.	1.153
 AS-100 BTB 1 5/8" x 6 1/2" x 12 ga.	1.716

Section Modulus Required for Trapeze Members (in.³)

Span of Trapeze	Pipe Size											
	1"	1 1/4"	1 1/2"	2"	2 1/2"	3"	3 1/2"	4"	5"	6"	8"	10"
1 ft. 6 in.	.08	.09	.09	.09	.10	.11	.12	.13	.15	.18	.24	.32
	.08	.09	.09	.10	.11	.12	.13	.15	.18	.22	.30	.41
2 ft. 0 in.	.11	.12	.12	.13	.13	.15	.16	.17	.20	.24	.32	.43
	.11	.12	.12	.13	.15	.16	.18	.20	.24	.29	.40	.55
2 ft. 6 in.	.14	.14	.15	.16	.17	.18	.20	.21	.25	.30	.40	.54
	.14	.15	.15	.16	.18	.21	.22	.25	.30	.36	.50	.68
3 ft. 0 in.	.17	.17	.18	.19	.20	.22	.24	.26	.31	.36	.48	.65
	.17	.18	.18	.20	.22	.25	.27	.30	.36	.43	.60	.82
4 ft. 0 in.	.22	.23	.24	.25	.27	.29	.32	.34	.41	.48	.64	.87
	.22	.24	.24	.26	.29	.33	.36	.40	.48	.58	.80	1.09
5 ft. 0 in.	.28	.29	.30	.31	.34	.37	.40	.43	.51	.59	.80	1.08
	.28	.29	.30	.33	.37	.41	.45	.49	.60	.72	1.00	1.37
6 ft. 0 in.	.33	.35	.36	.38	.41	.44	.48	.51	.61	.71	.97	1.30
	.34	.35	.36	.39	.44	.49	.54	.59	.72	.87	1.20	1.64
7 ft. 0 in.	.39	.40	.41	.44	.47	.52	.55	.60	.71	.83	1.13	1.52
	.39	.41	.43	.46	.51	.58	.63	.69	.84	1.01	1.41	1.92
8 ft. 0 in.	.44	.46	.47	.50	.54	.59	.63	.68	.81	.95	1.29	1.73
	.45	.47	.49	.52	.59	.66	.72	.79	.96	1.16	1.61	
9 ft. 0 in.	.50	.52	.53	.56	.61	.66	.71	.77	.92	1.07	1.45	
	.50	.53	.55	.59	.66	.74	.81	.89	1.08	1.30		
10 ft. 0 in.	.56	.58	.59	.63	.68	.74	.79	.85	1.02	1.19	1.61	
	.56	.59	.61	.65	.74	.82	.90	.99	1.20	1.44		

Top values are for Schedule 10 pipe; bottom values are for Schedule 40 pipe.

TECHNICAL DATA

INDEX

PRODUCT	DESCRIPTION	DATA	PRICING
CHANNEL			
AS 100	3¼" x 1½" 12 Gauge Channel	.5	.13
AS 100BTB	6½" x 1½" 12 Gauge Back-to-Back Channel	.5	.13
AS 150	2 ⁷ / ₁₆ " x 1½" 12 Gauge Channel	.6	.14
AS 150BTB	4 ⁷ / ₈ " x 1½" 12 Gauge Back-to-Back Channel	.6	.14
AS 200	1½" x 1½" 12 Gauge Channel	.7	.15
AS 200BTB	3¼" x 1½" 12 Gauge Back-to-Back Channel	.7	.16
AS 210	1½" x 1½" 14 Gauge Channel	.8	.17
AS 210BTB	3¼" x 1½" 14 Gauge Back-to-Back Channel	.8	.17
AS 300	1¾" x 1½" 12 Gauge Channel	.9	.18
AS 300BTB	2¾" x 1½" 12 Gauge Back-to-Back Channel	.9	.18
AS 400	1" x 1½" 12 Gauge Channel	.10	.19
AS 400BTB	2" x 1½" 12 Gauge Back-to-Back Channel	.10	.19
AS 500	1¾" x 1½" 14 Gauge Channel	.12	.20
AS 500BTB	1½" x 1½" 14 Gauge Back-to-Back Channel	.12	.20
AS 520	1¾" x 1½" 12 Gauge Channel	.11	.21
AS 520BTB	1½" x 1½" 12 Gauge Back-to-Back Channel	.11	.21
AS 707	Raceway Closure Strip	-	.22
AS 707P	Painted Closure Strip	-	.22

CHANNEL NUTS & HARDWARE

AS LS	Clamping Nut with Long Spring	.23	.24
AS NS	Clamping Nut without Spring	.23	.24
AS RS	Clamping Nut with Regular Spring	.23	.24
AS SS	Clamping Nut with Short Spring	.23	.24
AS TG	Top Grip Nut with Spring on Top	.23	.25
AS 517	Stud Nut with RS Spring	-	.25
AS 3281	Double Conveyor Adjusting Nuts	-	.25
AS 83	Hexagon Nut	-	.25
Fig. 135	Rod Coupling	-	.25
Fig. 146	Continous Threaded Rod	-	.25
AS 203	Linked Eyelet with Stud	-	.26
AS 209	Flat Washer	-	.26
AS 211	Lock Washer	-	.26
AS 230	Fender Washer	-	.26
AS 6075	Slotted Hex Head Machine Screw	-	.26
AS 6108	Square Nut	-	.26
AS 3500	Seismic Rod Stiffener	-	.27
AS 6024	Hex Head Cap Screw	-	.27

INDEX

PRODUCT	DESCRIPTION	PAGE	PRODUCT	DESCRIPTION	PAGE
FITTINGS AND ACCESSORIES					
AS 85	Rod or Insulator Support	.28	AS 708	Single Channel Bracket Support	.37
Fig. 86	Clamp with Lock Nut	.28	AS 710	"U" Support	.37
Fig. 93	Top Beam "C" Clamp (3/8" - 1/2")	.28	AS 711	"Z" Support	.37
Fig. 94	Top Beam "C" Clamp (5/8" - 3/4")	.28	AS 712	Cross Plate	.38
Fig. 95	Clamp with Lock Nut	.28	AS 714	"T" Plate	.38
AS 135X	Beam Clamp Light Duty	.29	AS 715	"T" Plate 90° Angle	.38
AS 601	Two Hole Splice Plate	.29	AS 718	Flat Angle Plate	.38
AS 602	Three Hole Splice Plate	.29	AS 719	Four Hole Corner Plate	.38
AS 603	Two Hole End Angle	.29	AS 720	RH/LH Angle Plate Connector	.39
AS 604	Two Hole Corner Angle	.29	AS 721	"U" Support	.39
AS 605	Three Hole Corner Angle	.30	AS 732	Shelf Bracket	.39
AS 606	Three Hole Corner Angle	.30	AS 733	Six Hole "U" Support	.39
AS 607	Four Hole Corner Angle	.30	AS 735	Eight Hole "U" Support	.39
AS 609	Two Hole Offset "Z" Support	.30	AS 744	Flat Corner Connector	.40
AS 611	"Z" Support	.30	AS 745	Three Hole Corner Angle	.40
AS 612	"Z" Support	.31	AS 747	Symmetrical Four Hole Connector	.40
AS 613	"U" Support	.31	AS 748	Four Hole Corner Joint Connector	.40
AS 614	Four Hole Joint Angle Connector	.31	AS 750	Four Hole Corner Connector	.40
AS 615	Five Hole Shelf Joint Angle Connector	.31	AS 763 & AS 764	Slotted Adj. Corner Angle	.40
AS 616	Four Hole Splice Clevis	.31	AS 781	Four Hole Open Angle Connector	.41
AS 617	Three Hole Swivel Plate	.32	AS 793	Four Hole Closed Angle Connector	.41
AS 619	Square Washer	.32	AS 806	Two Hole Angle with Impressions on Both Legs	.41
AS 620	Two Hole Connecting Plate	.32	AS 809	Double Channel Bracket	.41
AS 624	Two Hole Closed Angle Connector	.32	AS 821	Eight Hole Double Angle Connector	.42
AS 629	Three Hole Splice Clevis	.32	AS 825	RH/LH Pipe Axle Support	.42
AS 631	Two Hole Splice Clevis	.33	AS 838	RH/LH 6" thru 30" Shelf Bracket	.42
AS 633	Two Hole Open Angle Connector	.33	AS 854	Flat Connector	.42
AS 644	Two Hole Splice Clevis	.33	AS 855	Angular "I" Beam Clamp	.43
AS 645	Three Hole Splice Clevis	.33	AS 858	Heavy Duty Suspension Rod Beam Clamps	.43
AS 646	Four Hole Splice Clevis	.33	AS 865	Wide Throat Heavy Duty Beam Clamp	.43
AS 651	Reversible Strut Bracket	.34	AS 871	Safety Anchor Strap	.43
AS 655 & AS 656	Type "A" End Cap	.34	AS 888	Four Hole Splice Plate	.44
AS 661 T1	Strut Bracket (Slot Up)	.34	AS 901 & AS 902	Type "A" End Cap	.44
AS 661 T2	Strut Bracket (Slot Down)	.34	AS 907	"I" Beam Clamp	.44
AS 665	Four Hole Double Corner Connector	.34	AS 913	Ten Hole Two Angle Clevis Connector	.44
AS 666	Six Hole Double Corner Connector	.35	AS 921	One Hole Angle	.44
AS 667	Eight Hole Double Corner Connector	.35	AS 922	RH/LH Two Hole Single Corner Angle Connector	.45
AS 668	Six Hole Three Angle Connector	.35	AS 923	Five Hole Two Angle Connector	.45
AS 669	Twelve Hole Three Angle Clevis Connector	.35	AS 925	Symmetrical Three Hole Joint Connector	.45
AS 677	Cup Support for Standard Single Strut	.35	AS 926	Strut Brace	.45
AS 678	Three Hole "U" Support	.35	AS 927	Five Hole Corner Connector	.45
AS 679	"U" Support	.36	AS 928	"Z" Support	.46
AS 684	Beam Clamp	.36	AS 929	"U" Support	.46
AS 685	Beam Clamp	.36	AS 930	Type "A" End Cap	.46
AS 686	Beam clamp	.36	AS 978	"U" Support	.46
AS 687	Slotted "U" Support	.37	AS 993	Inside Clevis	.46
AS 689	Adj. Double Slotted Corner Connector	.37			

INDEX

PRODUCT DESCRIPTION	PAGE	PRODUCT DESCRIPTION	PAGE
FITTINGS AND ACCESSORIES (Continued)		PIPE AND CONDUIT SUPPORTS	
AS 998 1" Beam Clamp	.47	AS 51 Right Angle Pipe or Conduit Clamp	.57
AS 2064 Double Column Post Base	.47	Fig. 67 Pipe or Conduit Hanger	.57
AS 2112 Cross Connector	.47	Fig. 69 Swivel Ring Hanger	.57
AS 2119 "U" Connector	.47	Fig. 137 "U" Bolt with Nuts Long Tangent	.57
AS 2128 RH/LH Six Hole Corner Connector	.47	AS 270 Conduit Clamp	.58
AS 2144 Corner Angle	.48	AS 815 Double Roller Pipe Support	.58
AS 2190 Flat Corner Connector	.48	AS 1000 EMT Conduit Clamps	.58
AS 2401 - 2403 Ladder Rung	.48	AS 1000 Pre-Assembled EMT Conduit Clamps	.58
AS 2404 - 2408 Wall Ladder Bracket	.48	AS 1100 Rigid Steel Conduit Clamps	.59
AS 2421 45° Stair Tread Support	.48	AS 1100 Pre-Assembled Rigid Steel Conduit and Pipe Clamps	.59
AS 2422 37½° Stair Tread Support	.49	AS 1200 O.D. Tubing Clamp	.60
AS 2504 Square Washer with Channel Guide	.49	AS 1300 Universal Pipe Clamp	.61
AS 2511 End Cap with Knock Out	.49	AS 1300 Pre-Assembled Universal Clamp	.61
AS 2520 Two Hole Adjustment Angle	.49	AS 1450 One-Hole Clamp for O.D. Tubing	.61
AS 2521 Two Wheel Trolley	.49	AS 1901 Pipe Roller Support	.61
AS 2522 Four Wheel Trolley	.50	AS 1902 Pipe Roller Support	.61
AS 2524 Two Wheel Light Duty Trolley	.50	AS 1911 Pipe Roller	.62
AS 2525 Four Wheel Light Duty Trolley	.50	AS 3101 - 3115 One Piece Cable and Conduit Clamp	.62
AS 2528 Trolley Beam Standard Support	.50	AS 3126 Hold Down Clamp	.62
AS 2528-1 Trolley Beam Joint Support	.50	AS 3138 Parallel Pipe Clamp	.62
AS 2545 Slotted 90° Angle	.51	AS 3792 Cushion Strip	.63
AS 2560 & 2561 Conduit Connector Fitting Assembly	.51	AS 004OD - 106P Cushion Clamp Assembly	.63
AS 2580 Type "A" End Cap	.51		
AS 2601 "Z" Support	.51	KLO-SHURE®	
AS 2623 Swivel Adapter	.51	Insulation Coupling Clevis Hanger/Ring Hanger	.64
AS 2627 Spacer Clevis	.52	Strut Mounted Insulation Couplings with Strut Clamp	.65
AS 2631 Swing Gate Fixture Hanger	.52		
AS 2631D Swing Gate Fixture Hanger	.52	CONCRETE INSERTS	
AS 2648 "U" Support	.52	Fig. 152 Screw Concrete Insert	.66
AS 2651 Beam Clamp	.53	Fig. 285 Light Weight Concrete Insert	.66
AS 2654 & 2654A Column Attachment	.53	AS 349 Continuous Concrete Insert	.66 & 67
AS 2656 "U" Bolt Beam Clamp with Hook	.53	AS 449 Continuous Concrete Insert	.67
AS 2657 Double "U" Bolt Beam Clamp	.53	AS 653 Type "B" End Cap	.68
AS 3013 Single Column Post Base	.53	AS 654 Type "B" End Cap	.68
AS 3025 Post Base	.54	Fig. 284 Concrete Deck Insert	.68
AS 3029 Double Column Post Base	.54	AS 6151 Plastic Closure Strip	.68
AS 3033 Post Base	.54		
AS 3040 Post Base	.54		
AS 3049 Two Hole Slotted 90° Corner Connector	.54		
AS 3060 Offset Connector	.55		
AS 3064 Double Column Post Base	.55		
AS 3164 Double Channel Bracket Support	.55		
AS 3373 Universal Angle Bracket	.55		
AS 6153 Safety End Cap	.55		
AS 9400 Adjustable Base	.56		
AS 9402 Two Hole Hinge Connector	.56		
AS 9403 Three Hole Hinge Connector	.56		
AS 9404 Four Hole Hinge Connector	.56		

TERMS AND CONDITIONS

PRICE LIST

CONDITIONS AND TERMS OF SALE

1. CONTROLLING PROVISIONS:

These terms and conditions shall control with respect to any purchase order or sale of Seller's products. No waiver, alteration or modification of these terms and conditions whether on Buyer's purchase order or otherwise shall be valid unless the waiver, alteration or modification is specifically accepted in writing and signed by an authorized representative of Seller.

2. DELIVERY:

Seller will make every effort to complete delivery of products as indicated on Seller's acceptance of an order, but Seller assumes no responsibility or liability, and will accept no back charge, for loss or damage due to delay or inability to deliver caused by acts of God, war, labor difficulties, accident, delays of carriers, by contractors or suppliers, inability to obtain materials, shortages of fuel and energy, or any other causes of any kind whatever beyond the control of Seller. Seller may terminate any contract of sale of its products without liability of any nature, by written notice to Buyer, in the event that the delay in delivery or performance resulting from any of the aforesaid causes shall continue for a period of sixty (60) days. Under no circumstances shall Seller be liable for any special or consequential damages or for loss, damage, or expense (whether or not based on negligence) directly or indirectly arising from delays or failure to give notice of delay.

3. WARRANTY:

Seller warrants for one year from the date of shipment Seller's manufactured products to the extent that Seller will replace those having defects in material or workmanship when used for the purpose and in the manner which Seller recommends. If Seller examination shall disclose to its satisfaction that the products are defective, and an adjustment is required, the amount of such adjustment shall not exceed the net sales price of the defective products and no allowance will be made for labor or expense of repairing or replacing defective products or workmanship of damage resulting from the same. Seller warrants the products which it sells of other manufacturers to the extent of the warranties of their respective makers. Where engineering design or fabrication work is supplied. Buyer's acceptance of Seller's design or of delivery of work shall relieve Seller of all further obligation, other than expressed in Seller's product warranty. THIS IS SELLER'S SOLE WARRANTY. SELLER MAKES NO OTHER WARRANTY OF ANY KIND, EXPRESSED OR IMPLIED AND ALL IMPLIED WARRANTIES OF MERCHANTABILITY AND FOR A PARTICULAR PURPOSE WHICH EXCEED SELLER'S AFORESTATED OBLIGATION ARE HEREBY DISCLAIMED BY SELLER AND EXCLUDED FROM THIS WARRANTY. Seller neither assumes, nor authorizes any person to assume for it, any other obligation in connection with the sale of its engineering designs or products. This warranty shall not apply to any products or parts of products which (a) have been repaired or altered outside of Seller's factory, in any manner; (b) have been subjected to misuse, negligence or accidents; (c) have been used in a manner contrary to Seller's instructions or recommendations. Seller shall not be responsible for design errors due to inaccurate or incomplete information supplied by Buyer or its representatives.

4. SELLER'S LIABILITY:

Seller will not be liable for any loss, damage, cost of repairs, incidental or consequential damages of any kind, whether based upon warranty (except for the obligation accepted by Seller under "Warranty" above), contract or negligence, arising in connection with the design, manufacture, sale, use or repair of the products or of the engineering designs supplied to Buyer

5. RETURNS:

Seller cannot accept return of any products unless its written permission has been first obtained, in which case same will be credited subject to the following: (a) all material returned must, on its arrival at Seller's Plant, be found to be in first-class condition; if not, cost of putting in saleable condition will be deducted from credit memoranda; (b) a handling charge deduction of twenty percent (20%) will be made from all credit memoranda issued for material returned; and (c) transportation charges, if not prepaid will be deducted from credit memoranda.

6. SHIPMENTS:

All products sent out will be carefully examined, counted and packed. The cost of any special packing or special handling caused by Buyer's requirements or requests shall be added to the amount of the order. No claim for shortages will be allowed unless made in writing within ten (10) days of receipt of a shipment. Claims for products damaged or lost in transit should be made on the carrier, as Seller's responsibility ceases, and title passes, on delivery to the carrier.

7. SPECIAL PRODUCTS:

Orders covering special or nonstandard products are not subject to cancellation except on such terms as Seller may specify on application.

8. PRICES AND DESIGNS:

Prices and designs are subject to change without notice. All prices are F.O.B. Point of shipment, unless otherwise stated.

9. TAXES:

The amount of any sales, excise or other taxes, if any, applicable to the products covered by this order, shall be paid by Buyer unless Buyer provides Seller with an exemption certificate acceptable to the taxing authorities.

10. NUCLEAR PLANTS:

Where the products, engineering design or fabrication are utilized in nuclear plant applications, Buyer agrees: (a) to take all necessary steps to add Seller as an insured under the property insurance policies and nuclear liability insurance policies covering the nuclear power plant facility at which the products, engineering design or fabrication are utilized; (b) to obtain a waiver of any claims against Seller by the nuclear power plant owner and a waiver of subrogation against Seller from such owners' property insurer with respect to any loss or damage to property at the nuclear power plant site arising from the products, engineering design or fabrication; (c) to indemnify and hold Seller harmless against all claims, costs, expenses (including attorneys fees), loss, damage, or other liability that Seller would not have incurred but for Buyer's failure to comply with subsections (a) and (b) of this Section 10; and (d) to indemnify and hold Seller harmless with respect to any personal injury (or death), property damage or other loss resulting from a nuclear incident which is caused directly or indirectly by defective design, material or workmanship furnished by Seller.

11. MINIMUM INVOICE:

\$100.00 plus transportation.

12. TERMS:

Cash, net 30 days unless otherwise specified.

NOTE: All orders are accepted on the basis of prices in effect at the time of shipment.

NOTICE: The prices and terms quoted, there will be added any manufacturers or sales tax payable on the transaction under any effective statute.

FREIGHT ALLOWANCE:

All prices are F.O.B. point of shipment. On (non-engineered product) shipments of 2,500 pounds or more, rail freight or motor freight at the lowest published rates is allowed to all continental U.S. rail points or all U.S. highway points listed in published tariffs (Alaska and Hawaii excluded). In no case will more than actual freight be allowed.

NOTES

NOTES

NOTES

NOTES

NOTES



Corporate Offices
110 Corporate Drive, Suite 10 • P.O. Box 3180
Portsmouth, NH 03802-3180
Tel: 603-422-8000 • Fax: 603-422-8033
E-mail address — Webmaster@anvilintl.com
www.anvilintl.com

For Sales and Service Information Contact the Regional Service Center Nearest You or Visit Our Website at www.anvilintl.com

U.S. Regional Service Centers

NORTHEAST REGION

Servicing: Connecticut, Delaware, Maine, Maryland, Massachusetts, New Hampshire, New Jersey, New York, East Pennsylvania, Rhode Island, Vermont, Virginia

2530 Pearl Buck Road
Bristol, PA 19007
Tel: 215-788-4056 • Fax: 215-788-4475
Toll Free: 1-800-451-2935

MIDWEST REGION

Servicing: Illinois, Indiana, Iowa, Kansas, Kentucky, Michigan, Minnesota, Missouri, Nebraska, North and South Dakota, Ohio, West Pennsylvania, West Virginia, Wisconsin

750 Central Avenue
University Park, IL 60466
Tel: 708-534-1414 • Fax: 708-534-5441
Toll Free: 1-800-301-2701

SOUTHERN REGION

Servicing: Alabama, Arkansas, Colorado, Florida, Georgia, Louisiana, Mississippi, New Mexico, North and South Carolina, Oklahoma, Tennessee, Texas, Wyoming

1313 Avenue R
Grand Prairie, TX 75050
Tel: 972-343-9206 • Fax: 972-641-8946
Toll Free: 1-800-451-4414

WESTERN REGION

Servicing: Alaska, Arizona, California, Hawaii, Idaho, Montana, Nevada, Oregon, Utah, Washington

1385 Greg Street
Sparks, NV 89431
Tel: 775-331-7029 • Fax: 775-331-5075
Toll Free: 1-800-572-0051

EUROPE & MIDDLE EAST REGION

Rick van Meesen, *Business Director*
the Netherlands
Tel: +31 53 5725570
Fax: +31 53 5725579
U.S. Customer Service Tel: +1 708 534 1414

LATIN AMERICA, PUERTO RICO & MEXICO

Art Gutierrez, *Sales Manager*
Tel: 813-300-3721
U.S. Customer Service
Tel: 708-534-1414 • Fax: 708-534-5441

ANVILStar™

Fire Products Division of Anvil International

ANVILSTAR CUSTOMER SERVICE CENTER

Tel: 708-534-1414 • Fax: 708-534-5441
Toll Free: 1-800-301-2701