

HANDLE PARTS

ITEM NO.	NAME	NO. REQ'D	PART NO.	MATERIAL	REMARKS
1	HANDLE	1	202-321	DI	
2	LEVER	1	202-322	DI	
3	SPRING	1	204-323	316 SS	
4	PIN	1	204-324	316 SS	
5	SIDE BOLT	1	211-325	C.P. STEEL	
6	90° NOTCH PLATE	1	211-326	C.P. STEEL	
7	BOLTS	2	211-327	C.P. STEEL	
8	NUTS	2	211-327	C.P. STEEL	
9	WASHERS	2	211-327	C.P. STEEL	

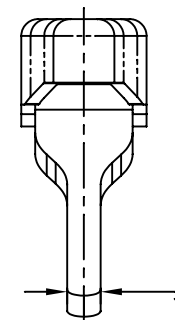
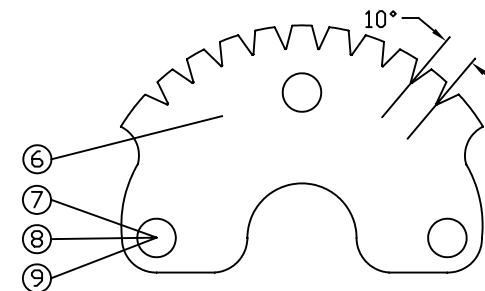
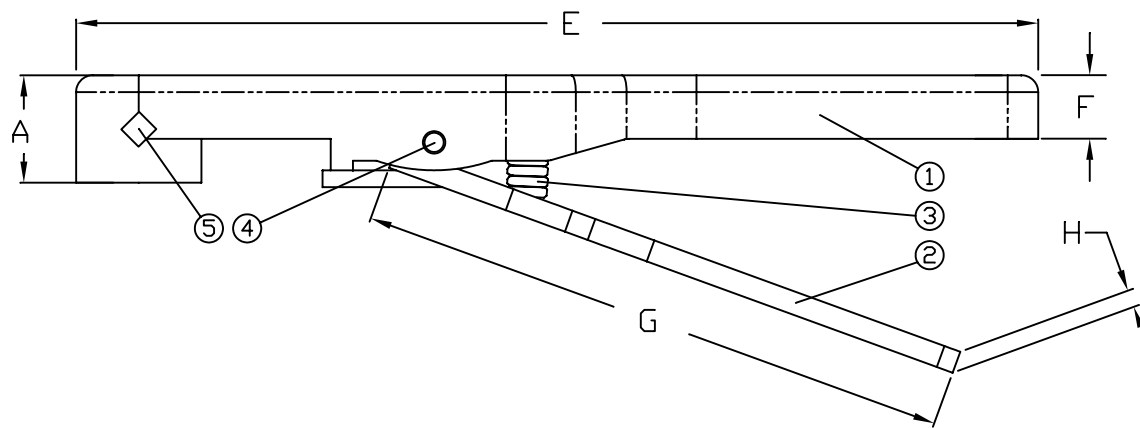
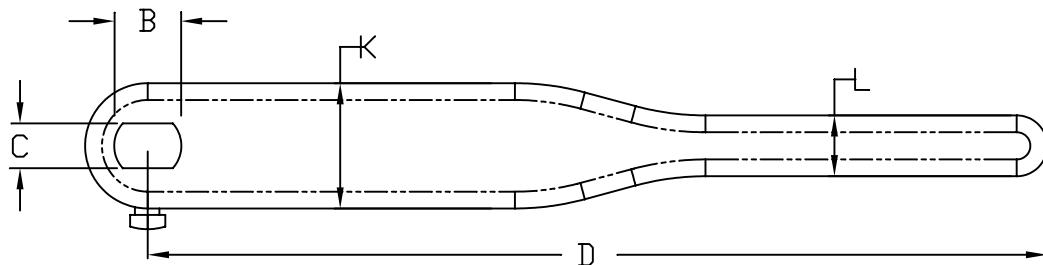

HANDLE DIMENSIONS

HANDLE SUBASSEMBLY NUMBER	A	B	C	D	E	F	G	H	J	K	L	WEIGHT
800-320-020-101-000	1.25	9/16	3/8	10.05	10.75	0.71	6.70	0.26	0.375	1.40	0.68	2.50 LBS
800-320-025-101-000	1.25	9/16	3/8	10.05	10.75	0.71	6.70	0.26	0.375	1.40	0.68	2.50 LBS
800-320-030-101-000	1.25	9/16	3/8	10.05	10.75	0.71	6.70	0.26	0.375	1.40	0.68	2.50 LBS
800-320-040-101-000	1.25	5/8	7/16	10.05	10.75	0.71	6.70	0.26	0.375	1.40	0.68	2.50 LBS
800-320-050-101-000	1.25	5/8	7/16	10.05	10.75	0.71	6.70	0.26	0.375	1.40	0.68	2.50 LBS
800-320-060-101-000	1.25	5/8	7/16	10.05	10.75	0.71	6.70	0.26	0.375	1.40	0.68	2.50 LBS
800-320-060-090-000	1.25	3/4	1/2	10.05	10.75	0.71	6.70	0.26	0.375	1.40	0.68	2.50 LBS
800-320-080-101-000	1.25	3/4	1/2	13.77	14.77	0.60	9.38	0.325	0.375	1.72	0.85	4.0 LBS
800-320-080-090-000	1.25	7/8	5/8	13.77	14.77	0.60	9.38	0.325	0.375	1.72	0.85	4.0 LBS
800-320-100-101-000	1.25	7/8	5/8	13.77	14.77	0.60	9.38	0.325	0.375	1.72	0.85	4.0 LBS
800-320-100-090-000	1.25	1 1/8	RD.	13.77	14.77	0.60	9.38	0.325	0.375	1.72	0.85	4.0 LBS
800-320-120-101-000	1.25	1 1/8	RD.	13.77	14.77	0.60	9.38	0.325	0.375	1.72	0.85	4.0 LBS
800-320-120-090-000	1.25	1 1/8	RD.	13.77	14.77	0.60	9.38	0.325	0.375	1.72	0.85	4.0 LBS



PROPRIETARY AND CONFIDENTIAL  
 THE INFORMATION CONTAINED IN THIS DRAWING IS THE SOLE PROPERTY OF ABZ VALVES & CONTROLS. ANY REPRODUCTION IN PART OR AS A WHOLE WITHOUT THE WRITTEN PERMISSION OF ABZ VALVES & CONTROLS IS PROHIBITED.

ABZ VALVES & CONTROLS

TITLE:  
 STANDARD HANDLE ASSEMBLY  
 DRIVE HOLE VARIES

SIZE	DWG. NO.	REV
C	HANDLE 1	
DATE:	03-07-05	SHEET 1 OF 1