

November 2011

For the most current product/pricing information on Anvil products, please visit our website at www.anvilintl.com.



Pipe Hangers and Supports

BUILDING CONNECTIONS THAT LAST

BUILDING CONNECTIONS THAT LAST



For over 150 years, Anvil has worked diligently to build a strong, vibrant tradition of making connections — pipe to pipe and people to people.

We pride ourselves in providing the finest-quality pipe products and services with integrity and dedication to superior customer service at all levels.



We provide expertise and product solutions for a wide range of applications, from plumbing, mechanical, HVAC, industrial and fire protection to mining, oil and gas. Our comprehensive line of products includes: grooved pipe couplings, grooved and plain-end fittings, valves, cast and malleable iron fittings, forged steel fittings, steel pipe nipples and couplings, pipe hangers and supports, channel and strut fittings, mining and oil field fittings, along with much more.



As an additional benefit to our customers, Anvil offers a complete and comprehensive Design Services Analysis for mechanical equipment rooms, to help you determine the most effective and cost-efficient piping solutions.

Anvil is a proud member of the United States Green Building Council (USGBC). Go to the Anvil website to obtain manufacturer recycled certificates and other Green information.

At Anvil, we believe that responsive and accessible customer support is what makes the difference between simply delivering products — and delivering solutions.

Pipe Hangers and Supports



Manufacturing Excellence

Anvil Pipe Hangers and Supports are manufactured in three primary U.S. locations: North Kingstown, Rhode Island; Henderson, Tennessee and Columbia, Pennsylvania, each with its own unique capabilities.

At 150,000 square feet, our Pipe Support design and fabrication facility in North Kingstown, Rhode Island is the industry leader in the Engineered Hanger Market for experience and in house manufacturing capability. Our equipment can accommodate any project since we have the capability to machine, saw and flame cut up to 3" thick carbon and alloy steel and plasma cut stainless steel.

We thread rod through 4" in diameter and we hot form small to large diameter clamps. Our facility also has complete in house blasting and painting capability and we perform complete in house Non-Destructive Examination including Liquid Penetrant, Ultrasonic and Magnetic Particle examination. This expertise is supported by our total quality programs including our ASME "NPT" Nuclear Certificate of Authorization, "NS" Certificate of Authorization and, ISO 9001.

Our manufacturing facility in Henderson, Tennessee has over 175,000 square feet of manufacturing capability dedicated to producing a complete line of commercial, light industrial and industrial Pipe Hangers and Supports. These include clamps, braces, inserts, rods and attachments, slides and guides to exacting industry standards and certified to ISO 9001 quality. The products manufactured in Henderson are designed for use in a wide variety of rigid Pipe Hanger or Support applications, in markets including fire protection, electrical, water and waste water treatment, petrochemical, seismic, industrial and commercial. Special fabrication is available from our Henderson facility as well.

At our Columbia, Pennsylvania Foundry, where we manufacture malleable fittings, cast iron fittings and our Gruvlok® products, we also manufacture our malleable and ductile iron Hanger Products such as beam clamps, numerous types of pipe clamps, concrete inserts, ceiling flanges and different types of rod attachments. With over 600,000 square feet of manufacturing floor space under roof, our foundry has an annual pouring capacity of 100,000 tons. Columbia is ISO 9001 certified and is a quality manufacturer of malleable, ductile and cast iron products. In addition to these three facilities Anvil also has Hanger fabrication facilities in Houston, Texas to service the Gulf Coast Engineered Hanger requirements.

Customer Service

With four key stocking locations throughout North America, you can count on getting all of the product you need - when you need it. When you have installation questions our solid customer service personnel are there to answer all of your questions, backed by our designers or engineers we are there for you - on site if needed.

Custom Engineering Options

In addition to its full range of high-quality hangers, Anvil offers a number of custom options to meet any special project requirements you may have.

Engineered Hangers Product Line

- Variable Springs
- Constant Supports
- Hydraulic Snubbers
- Vibration Sway Braces
- Sway Struts

We also provide:

- Special Fabrication/
Miscellaneous Structural/
Steel Fabrication
- Special Design Products
Per Customer Specifications
- Domestic Manufactured
Product Line

Design Services

Either on or off-site, Anvil Design Services helps you maximize the efficiency of your pipe support systems.

These services include:

- Pipe Hanger Design & Engineering
- Manual & Computer-Aided Drafting
- System Analysis
- Pipe Stress Analysis
- Product Qualification Testing (environmental static and cycling loads, flow and leak)
- Supervision of Client Design Personnel

TABLE OF CONTENTS

General Notes through Straps

General Notes

Standard Materials	15
Standard Galvanizing Practice.....	16 - 17

Copper Tubing Hangers

Fig. CT-69 Adjustable Swivel Ring.....	18
Fig. CT-65 Light Duty Adjustable Clevis.....	19
Fig. CT-128R Rod Threaded Ceiling Flange.....	20
Fig. CT-138R Extension Split Tubing Clamp.....	20
Fig. 69F Adjustable Swivel Ring, Felt Lined.....	21
Fig. 67F Copper Tube Felt Lined Hanger.....	22
Fig. CT-121 Copper Tubing Riser Clamp.....	23
Fig. CT-255 Copper Tubing Alignment Guide.....	24 - 25

CPVC Pipe Hangers

Fig. 185 One Hole Pipe Strap.....	26
Fig. 186 Two Hole Pipe Strap.....	27
Fig. 187 Two Hole 90° Side Mount Strap.....	28
Fig. 188 Two Hole Stand Off Strap.....	29

Pipe Rings

Fig. 108 Split Pipe Ring.....	30
Fig. 138R Extension Split Pipe Clamp.....	31
Fig. 104 Adjustable Swivel Ring, Split Ring Type.....	32
Fig. 69 Adjustable Swivel Ring, Tapped per NFPA Standards.....	33

Clevis

Fig. 67 Pipe or Conduit Hanger.....	34
Fig. 65 Light Duty Adjustable Clevis.....	35
Fig. 260 Adjustable Clevis Hanger.....	36
Fig. 260 ISS Clevis Hanger with Insulation Saddle System.....	37 - 39
Fig. 300 Adjustable Clevis for Insulated Lines.....	40
Fig. 590 Adjustable Clevis for Ductile or Cast Iron Pipe.....	41

Steel Pipe Clamps

Fig. 261 Extension Pipe or Riser Clamp.....	42
Fig. 40 Riser Clamp – Standard.....	43
Fig. 103 Offset Pipe Clamp.....	44
Fig. 100 Extended Pipe Clamp.....	44
Fig. 212 Medium Pipe Clamp.....	45
Fig. 212FP Earthquake Bracing Clamp.....	46
Fig. 216 Heavy Pipe Clamp.....	47
Fig. 295 Double Bolt Pipe Clamp.....	48
Fig. 295A Alloy Double Bolt Pipe Clamp.....	49
Fig. 295H Heavy Duty Double Bolt Pipe Clamp.....	50
Fig. 224 Alloy Steel Pipe Clamp.....	51
Fig. 246 Heavy Duty Alloy Steel Pipe Clamp.....	52

Socket Clamps

Fig. 595 & Fig. 594 Socket Clamp for Ductile Iron or Cast Iron Pipe.....	53
Fig. 600 & Fig. 599 Socket Clamp for Ductile Iron or Cast Iron Pipe.....	54

Beam Clamps

Fig. 86 & Fig. 88 C-Clamp.....	55
Fig. 95 C-Clamp with Locknut.....	56
Fig. 89 & 89X Retaining Clip.....	57
Fig. 92 Universal C-Type Clamp (Standard Throat).....	58
Fig. 93 Universal C-Type Clamp (Wide Throat).....	59
Fig. 94 Wide Throat Top Beam C-Clamp.....	60
Fig. 227 Top Beam Clamp.....	61
Fig. 217 Adjustable Side Beam Clamp.....	62
Fig. 14 Adjustable Side Beam Clamp.....	62
Fig. 133 Standard Duty Beam Clamp.....	63
Fig. 134 Heavy Duty Beam Clamp.....	63
Fig. 218 Malleable Beam Clamp without Extension Piece.....	64
Fig. 228 Universal Forged Steel (UFS) Beam Clamp.....	65
Fig. 292 & Fig. 292L Universal Forged Steel (UFS) Beam Clamp.....	66

Structural Attachments

Fig. 55 & Fig. 55L Structural Welding Lug.....	67
Fig. 54 Two Hole Welding Beam Lug.....	68
Fig. 66 Welded Beam Attachment.....	69
Fig. 60 Steel Washer Plate.....	70
Fig. 112 Brace Fitting Complete.....	71
Fig. 113 Brace Fitting (Pipe End Only).....	71

Brackets

Fig. 202 Iron Side Beam Bracket.....	72
Fig. 206 Steel Side Beam Bracket.....	73
Fig. 207 Threaded Steel Side Beam Bracket.....	73
Fig. 189 Straight Eye Socket.....	74
Fig. 190 Off-Set Eye Socket.....	75
Fig. 194 Light Welded Steel Bracket.....	76
Fig. 195 Medium Welded Steel Bracket.....	77
Fig. 199 Heavy Welded Steel Bracket.....	78

Ceiling Plates & Ceiling Flanges

Fig. 395 Cast Iron Ceiling Plate.....	79
Fig. 127 Plastic Ceiling Plate.....	79
Fig. 128R Rod Threaded Ceiling Flange.....	80
Fig. 153 Pipe Hanger Flange.....	81

Concrete Inserts & Attachments

Fig. 152 Screw Concrete Insert.....	82
Fig. 282 Universal Concrete Insert.....	83
Fig. 281 Wedge Type Concrete Insert.....	84
Fig. 285 Light Weight Concrete Insert.....	85
Fig. 286 Iron Cross.....	86
Fig. 284 Metal Deck Hanger.....	87
Fig. 47 Concrete Single Lug Plate.....	88
Fig. 49 Concrete Clevis Plate.....	89
Fig. 52 Concrete Rod Attachment Plate.....	90

Hanger Rods

Fig. 142 Coach Screw Rods.....	91
Fig. 146 Continuous Threaded Rod.....	91
Fig. 140 Machine Threaded Rods (Right-Hand Threads).....	92
Fig. 253 Machine Threaded Rods (Right and Left-Hand Threads).....	92
Fig. 248 & Fig. 248L Eye Rod (Not Welded).....	92
Fig. 278 & Fig. 278L Eye Rod (Welded).....	93
Fig. 248X Linked Eye Rods (Not Welded).....	93
Fig. 278X Linked Eye Rods (Welded).....	93
Fig. 148 Rod with Eye End.....	94

Rod Attachments

Fig. 135, Fig. 135E & Fig. 135R Rod Coupling.....	95
Fig. 136 & Fig. 136R Rod Coupling.....	95
Fig. 114 Turnbuckle Adjuster.....	96
Fig. 110R Socket, Rod Threaded.....	96
Fig. 157 Extension Piece.....	97
Fig. 290 & Fig. 290L Weldless Eye Nut.....	97
Fig. 299 Forged Steel Clevis.....	98
Fig. 233 Turnbuckle.....	99
Fig. 230 Turnbuckle.....	99

Bolts, Nuts, Pins & U-Bolts

Fig. 291 Clevis Pin with Cotter.....	100
Machine Bolts & Hexagon Nuts.....	101
Fig. 137, Fig. 137S Standard & Special U-Bolts.....	102
Fig. 137C Plastic Coated U-Bolt.....	103
Fig. 120 Light Weight U-Bolts.....	103

Straps

Fig. 126 One-Hole Clamp.....	104
Fig. 262 Strap Short.....	104
Fig. 243 & 244 Pipe Strap.....	105

Pipe Supports through Index

Pipe Supports

Fig. 62 Pipe Stanchion.....	106
Fig. 63 Pipe Stanchion.....	107
Fig. 192 Adjustable Pipe Saddle.....	108
Fig. 191 Adjustable Pipe Saddle with U-Bolt.....	108
Fig. 258 Pipe Saddle Support.....	109
Fig. 264 Adjustable Pipe Saddle Support.....	110
Fig. 265 Adjustable Pipe Saddle Support with U-Bolt.....	111
Fig. 259 Pipe Saddle Support with U-Bolt.....	112

Trapeze

Fig. 46 Universal Trapeze Assembly.....	113
Fig. 45 Channel Assembly.....	114
Fig. 50 Equal Leg Angle for Trapeze Assembly.....	115

Pipe Shields & Saddles

Fig. 167 Insulated Protection Shield.....	116
Fig. 168 Rib-Lok Shield.....	117
Fig. 160 to Fig. 166A Pipe Covering Protection Saddle.....	118 - 121

Pipe Rolls

Fig. 177 Adjustable Pipe Roll Support.....	122
Fig. 171 Single Pipe Roll.....	123
Fig. 178 Spring Cushion Hanger.....	124
Fig. 181 Adjustable Steel Yoke Pipe Roll.....	125
Fig. 175 Roller Chair.....	126
Fig. 277 Pipe Roll and Base Plate.....	127
Fig. 271 Pipe Roll Stand.....	128
Fig. 274, Fig. 274P & Fig. 275 Adjustable Pipe Roll Stand.....	129

Pipe Guide & Slides

Fig. 255 Pipe Alignment Guide.....	130 - 131
Fig. 256 Pipe Alignment Guide.....	132 - 133
Fig. 257 & Fig. 257A Structural Tee Slide Assembly.....	134 - 137
Fig. 436 & Fig. 436A Fabricated Tee Slide Assembly.....	134 - 137
Fig. 439 & Fig. 439A Structural "H" Slide Assembly.....	138 - 139
Fig. 432 Special Clamp.....	140
Fig. 212 Medium Pipe Clamp.....	141

Spring Hangers

Fig. 82, B-268, 98, Triple & Quadruple Springs.....	142 - 143
Spring Hanger Size & Series Selection.....	144 - 145
Check List.....	146
Fig. B-268, Fig. C-268 Type A.....	147
Fig. B-268, Fig. C-268 Type B & C.....	148
Fig. B-268, Fig. C-268 Type D & E.....	149
Fig. B-268, Fig. C-268 Type F.....	150
Fig. B-268, Fig. C-268 Type G.....	151
Fig. 82, Fig. C-82 Series Short Spring.....	152 - 153
Fig. 98, Fig. C-98 Series Double Spring.....	154 - 155
Triple Spring, Triple Spring-CR Series.....	156 - 157
Quadruple Spring, Quadruple Spring-CR Series.....	158 - 159

Constant Supports

Model R 80-V, C-80-V Vertical & 81-H, C-81-H Horizontal.....	160 - 163
Total Travel & Selection Chart.....	164 - 167
Fig. 80-V Type A.....	168
Fig. 80-V Type B.....	169
Fig. 80-V Type C.....	170
Fig. 80-V Type D.....	171
Fig. 80-V Type E.....	172
Fig. 80-V Type G.....	173
Fig. 80-V Type A, B & C Size 84-110.....	174
Fig. 81-H Type A.....	175
Fig. 81-H Type B.....	176

Fig. 81-H Type C.....	177
Fig. 81-H Type D.....	178
Fig. 81-H Type E.....	179
Fig. 81-H Type F Upthrust.....	180
Fig. 81-H Type A, B, C & E Size 84-110.....	181
Fig. 80-V and Fig. 81-H Weight Chart.....	182
Check List.....	183
Fig. 170 Horizontal Traveler.....	184

Vibration Control & Sway Brace

Fig. 296, 301, C-296, C-301.....	185 - 186
Fig. 297, 298, 302, 303.....	187

Sway Strut Assembly

Fig. 211, C-211, 640, C-640 Sway Strut Assembly.....	188 - 189
Fig. 222, C-222 Mini-Sway Strut Assembly.....	190 - 191

Snubbers

Fig. 3306, 3307 Hydraulic Snubber.....	192 - 195
Fig. 200, C-200, 201, C-201 Hydraulic Snubber.....	196 - 199
Fig. 312 Tapered Pin.....	200

Special Design Products

Fig. 38SD Half Clamp.....	201
Fig. 53SD Welding Lug for L.R. Elbow.....	201
Fig. 71SD Double Roll Horizontal Traveler.....	201
Fig. 72SD Dual Direction Horizontal Traveler.....	202
Fig. 75SD Flat Roller with Saddle.....	202
Fig. 76SD Fabricated Roller for Large Diameter Pipe.....	202
Fig. 40SD Riser Clamp.....	203
Fig. 41SD Non-Standard Three Bolt Pipe Clamp.....	203
Fig. 42SD Non-Standard Two Bolt Pipe Clamp.....	204

Application Assembly Examples.....	205 - 212
------------------------------------	-----------

Pipe Hanger Specifications.....	213 - 214
---------------------------------	-----------

Master Format 3 Part Specification.....	215 - 224
---	-----------

Technical Data

Pipe Support Spacing.....	225 - 226
Steel Pipe Data.....	227 - 228
Copper Tube Data.....	228
Soil Pipe Data.....	229
AWWA Ductile Iron Pipe Data.....	229
PVC Plastic Pipe Data.....	230
Thermal Expansion of Pipe Material.....	231 - 232
Threaded Rod Data.....	233
Maximum Recommended Applied Torques.....	233
Beam Dimensions.....	234

Anvil Compliances, Listings and Approvals.....	235 - 240
--	-----------

Anvil Pipe Hanger & Support Services.....	241
---	-----

Anvil Terms of Sale and Conditions.....	242
---	-----

Index

Subject Index.....	243
Numerical Index.....	244 - 245

Anvil reserves the right to make specification changes without notice. While every effort has been made to assure the accuracy of information contained in this catalog at the time of publication, we cannot accept responsibility for inaccuracies resulting from undetected errors or omissions.

The acceptability of galvanized coatings at temperatures above 450°F is at the discretion of the end user.

Rod load ratings shown in this catalog are based upon MSS-SP-58 (2002 and later).

PICTORIAL TABLE OF CONTENTS

Copper Tubing Hangers — Pipe Rings





COPPER TUBING HANGERS

 <p>Fig. CT-69 Adjustable Swivel Ring Size Range: 1/2" thru 4" Page 18</p>	 <p>Fig. CT-65 Light Duty Adjustable Clevis Size Range: 1/2" thru 4" Page 19</p>	 <p>Fig. CT-138R Extension Split Tubing Clamp Size Range: 1/2" thru 2" Page 20</p>	 <p>Fig. 69F Adjustable Swivel Ring Felt Lined Size Range: 1/2" thru 6" Page 21</p>	 <p>Fig. 67F Copper Tube Felt Lined Hanger Size Range: 1/2" thru 6" Page 22</p>
 <p>Fig. CT-255 Copper Tubing Alignment Guide Size Range: 1" thru 4" Pages 24-25</p>	 <p>Fig. CT-121 Copper Tubing Riser Clamp Size Range: 1/2" thru 4" Page 23</p>		 <p>Fig. CT-128R Rod Threaded Ceiling Flange Size Range: 3/8" thru 1/2" Page 20</p>	

CPVC PIPE HANGERS

 <p>Fig. 185 One Hole Pipe Strap Size Range: 3/4" thru 2" Page 26</p>	 <p>Fig. 186 Two Hole Pipe Strap Size Range: 3/4" thru 2" Page 27</p>	 <p>Fig. 187 Two Hole 90° Side Mount Strap Size Range: 3/4" thru 2" Page 28</p>	 <p>Fig. 188 Two Hole Stand Off Strap Size Range: 3/4" thru 2" Page 29</p>
---	---	--	--

PIPE RINGS

 <p>Fig. 108 Split Pipe Ring Size Range: 3/8" thru 8" Page 30</p>	 <p>Fig. 138R Extension Split Pipe Clamp Size Range: 3/8" thru 3" Page 31</p>	 <p>Fig. 104 Adjustable Swivel Ring, Split Ring Type Size Range: 3/4" thru 8" Page 32</p>	 <p>Fig. 69 Adjustable Swivel Ring Size Range: 1/2" thru 8" Page 33</p>
---	---	--	---

Clevis — Steel Pipe Clamps

CLEVIS

 <p>Fig. 67 Pipe or Conduit Hanger Size Range: 1/2" thru 6" Page 34</p>	 <p>Fig. 65 Light Duty Adjustable Clevis Size Range: 3/8" thru 4" Page 35</p>	 <p>Fig. 260 Adjustable Clevis Hanger Size Range: 1/2" thru 30" Page 36</p>
 <p>Fig. 260 ISS Clevis Hanger with Insulation Saddle System Size Range: 2" thru 16" Pages 37 - 39</p>	 <p>Fig. 300 Adjustable Clevis for Insulated Lines Size Range: 3/4" thru 12" Page 40</p>	 <p>Fig. 590 Adjustable Clevis for Ductile or Cast Iron Size Range: 3" thru 24" Page 41</p>

STEEL PIPE CLAMPS

 <p>Fig. 261 Extension Pipe or Riser Clamp Size Range: 3/4" thru 24" Page 42</p>	 <p>Fig. 40 Riser Clamp Standard Size Range: 2" thru 24" Page 43</p>	 <p>Fig. 103 Offset Pipe Clamp Size Range: 3/4" thru 8" Page 44</p>	 <p>Fig. 100 Extended Pipe Clamp Size Range: 1/2" thru 8" Page 44</p>
 <p>Fig. 212 Medium Pipe Clamp Size Range: 1/2" thru 30" Page 45</p>	 <p>Fig. 212FP Earthquake Bracing Clamp Size Range: 2 1/2" thru 12" Page 46</p>	 <p>Fig. 216 Heavy Pipe Clamp Size Range: 3" thru 42" Page 47</p>	 <p>Fig. 295 Double Bolt Pipe Clamp Size Range: 3/4" thru 36" Page 48</p>
 <p>Fig. 295A Alloy Double Bolt Pipe Clamp Size Range: 1 1/2" thru 24" Page 49</p>	 <p>Fig. 295H Heavy Duty Double Bolt Pipe Clamp Size Range: 6" thru 36" Page 50</p>	 <p>Fig. 224 Alloy Steel Pipe Clamp Size Range: 4" thru 16" Page 51</p>	 <p>Fig. 246 Heavy Duty Alloy Steel Pipe Clamp Size Range: 10" thru 24" Page 52</p>

PICTORIAL TABLE OF CONTENTS

Socket Clamps — Structural Attachments



SOCKET CLAMPS

 <p>Fig. 595 & 594 Socket Clamp for Ductile Iron or Cast Iron Pipe & Socket Clamp Washer Size Range: 4" thru 24" pipe Page 53</p>	 <p>Fig. 600 & 599 Socket Clamp for Ductile Iron or Cast Iron Pipe & Socket Clamp Washer Size Range: 3" thru 24" pipe Page 54</p>
---	---

BEAM CLAMPS















 <p>Fig. 86 & 88 C-Clamp with Set Screw and Lock Nut Size Range: 3/8" thru 3/4" Page 55</p>	 <p>Fig. 95 C-Clamp with Locknut Size Range: 3/8" and 1/2" Page 56</p>	 <p>Fig. 89 Retaining Clip Size Range: 3/8" thru 1/2" Page 57</p>	 <p>Fig. 89X Retaining Clip Size Range: 3/8" thru 3/4" Page 57</p>	 <p>Fig. 92 Universal C-Type Clamp Standard Throat Size Range: 3/8" and 1/2" Page 58</p>
 <p>Fig. 93 Universal C-Type Clamp Wide Throat Size Range: 3/8" and 1/2" Page 59</p>	 <p>Fig. 94 Wide Throat Top Beam C-Clamp Size Range: 5/8" and 3/4" Page 60</p>	 <p>Fig. 227 Top Beam Clamp Page 61</p>	 <p>Fig. 14 Adjustable Side Beam Clamp Size Range: 3/8" thru 3/8" Page 62</p>	 <p>Fig. 217 Adjustable Side Beam Clamp Size Range: 3" thru 7 7/8" Page 62</p>
 <p>Fig. 133 Standard Duty Beam Clamp Size Range: 4" thru 12" Page 63</p>	 <p>Fig. 134 Heavy Duty Beam Clamp Size Range: 4" thru 12" Page 63</p>	 <p>Fig. 218 Malleable Beam Clamp without Extension Piece Page 64</p>	 <p>Fig. 228 Universal Forged Steel Beam Clamp Page 65</p>	 <p>Fig. 292 & 292L Universal Forged Steel Beam Clamp with Weldless Eye Nut Page 66</p>

STRUCTURAL ATTACHMENTS





 <p>Fig. 55 & 55L Structural Welding Lug Size Range (55): 1/2" thru 3 3/4" Size Range (55L): 1/2" thru 2" Page 67</p>	 <p>Fig. 54 Two-Hole Welding Beam Lug Size Range: 1/2" thru 2 1/4" Page 68</p>	 <p>Fig. 66 Welding Beam Attachment Size Range: 3/8" thru 3 1/2" Page 69</p>	 <p>Fig. 60 Steel Washer Plate Size Range: 3/8" thru 3 3/4" Page 70</p>	 <p>Fig. 112 & 113 Brace Fitting Complete Size Range: 1" and 1 1/4" Page 71</p>
---	--	--	--	---

Brackets — Concrete Inserts & Attachments













BRACKETS

  <p>Fig. 202 Iron Side Beam Bracket Size Range: 3/8" thru 5/8" Page 72</p>	  <p>Fig. 206 Steel Side Beam Bracket Size Range: 3/8" thru 5/8" Page 73</p>	  <p>Fig. 207 Threaded Steel Side Beam Bracket Size Range: 3/8" and 1/2" Page 73</p>	  <p>Fig. 189 Straight Eye Socket Size: 3/8" Page 74</p>
  <p>Fig. 190 Off-Set Eye Socket Size: 3/8" Page 75</p>	  <p>Fig. 194 Light Welded Steel Bracket Page 76</p>	 <p>Fig. 195 Medium Welded Steel Bracket Page 77</p>	 <p>Fig. 199 Heavy Welded Steel Bracket Page 78</p>

CEILING PLATES

 <p>Fig. 127 Plastic Ceiling Plate Size Range: 3/8" and 1/2" Page 79</p>	 <p>Fig. 395 Cast Iron Ceiling Plate Size Range: 1/2" thru 8" Page 79</p>	 <p>Fig. 128R Rod Threaded, Ceiling Flange Size Range: 3/8" and 1/2" Page 80</p>	  <p>Fig. 153 Pipe Hanger Flange Size Range: 3/8" thru 3/4" Page 81</p>
--	---	---	--









CONCRETE INSERTS & ATTACHMENTS

  <p>Fig. 152 Screw Concrete Insert Size Range: 3/8" thru 7/8" Page 82</p>	  <p>Fig. 282 Universal Concrete Insert Size Range: 3/8" thru 7/8" Page 83</p>	  <p>Fig. 281 Wedge Type Concrete Insert Size Range: 1/4" thru 7/8" Page 84</p>	  <p>Fig. 285 Light Weight Concrete Insert Size Range: 1/4" thru 3/8" Page 85</p>	 <p>Fig. 286 Iron Cross Size Range: 3/4" thru 1 1/2" Page 86</p>	 <p>Fig. 284 Metal Deck Hanger Size Range: 3/8" thru 3/4" Page 87</p>
 <p>Fig. 47 Concrete Single Lug Plate Size Range: 1/2" thru 2" Page 88</p>	 <p>Fig. 49 Concrete Clevis Plate Size Range: 3/8" thru 1 3/4" Page 89</p>	 <p>Fig. 52 Concrete Rod Attachment Plate Size Range: 3/8" thru 1 1/4" Page 90</p>			



PICTORIAL TABLE OF CONTENTS

Hanger Rods & Attachments — Straps

HANGER RODS & ATTACHMENTS

 <p>Fig. 142 Coach Screw Rods Machine Threaded on Opposite End Size Range: 3/8" thru 1/2" Page 91</p>		 <p>Fig. 146 Continuous Thread Size Range: 1/4" thru 1 1/2" Page 91</p>		 <p>Fig. 140 & 253 Machine Threaded Rods Threaded on Both Ends Size Range: 3/8" thru 5" Page 92</p>			
 <p>Fig. 248 Eye Rod Not Welded Size Range: 3/8" thru 2 1/2" Page 92</p>	 <p>Fig. 278 Eye Rod Welded Size Range: 3/8" thru 2 1/2" Page 93</p>	 <p>Fig. 248X Linked Eye Rods Size Range: 3/8" thru 2 1/2" Page 93</p>	 <p>Fig. 278X Linked Eye Rods Welded Size Range: 3/8" thru 2 1/2" Page 93</p>	 <p>Fig. 148 Rod with Eye End Size Range: 2 3/4" thru 5" Page 94</p>	 <p>Fig. 135 & 135E Straight Rod Coupling Size Range: 1/4" thru 1" Page 95</p>	 <p>Fig. 136 & 136R Straight Rod Coupling Size Range: 1/4" thru 1" Page 95</p>	 <p>Fig. 114 Turnbuckle Adjuster Size Range: 1/4" thru 3/4" Page 96</p>
 <p>Fig. 110R Socket, Rod Threaded Size Range: 1/4" thru 7/8" Page 96</p>	 <p>Fig. 157 Extension Piece Size Range: 3/8" thru 7/8" Page 97</p>	 <p>Fig. 290 Weldless Eye Nut Size Range: 3/8" thru 2 1/2" Page 97</p>	 <p>Fig. 299 Forged Steel Clevis Size Range: 3/8" thru 4" Page 98</p>	 <p>Fig. 230 Turnbuckle Size Range: 3/8" thru 2 1/2" Page 99</p>	 <p>Fig. 233 Turnbuckle Size Range: 1 1/4" thru 5" Page 99</p>	 <p>Fig. 291 Clevis Pin with Cotters Size Range: 1/2" thru 4" Page 100</p>	 <p>Machine Bolts and Hex Nuts Page 101</p>

U-BOLTS







 <p>Fig. 137 & 137S Standard U-Bolts Size Range: 1/2" thru 36" Page 102</p>	 <p>Fig. 137C Plastic Coated U-Bolts Size Range: 1/2" thru 8" Page 103</p>	 <p>Fig. 120 Light Weight U-Bolt Size Range: 1/2" thru 10" Page 103</p>
---	--	---

STRAPS



 <p>Fig. 262 Strap Short Size Range: 1/2" thru 4" Page 104</p>	 <p>Fig. 126 One-Hole Clamp Size Range: 3/8" thru 4" Page 104</p>	 <p>Fig. 243 Pipe Strap Size Range: 1/2" thru 6" pipe Page 105</p>	 <p>Fig. 244 Pipe Strap Size Range: 1/2" thru 6" pipe Page 105</p>
--	--	--	--

Pipe Supports – Pipe Shields & Saddles



PIPE SUPPORTS

 <p>Fig. 62 Type A, B, and C Pipe Stanchion Size Range: 2" thru 18" Page 106</p>	 <p>Fig. 63 Type A, B, and C Pipe Stanchion Size Range: 2½" thru 42" Page 107</p>	 <p>Fig. 192 Adjustable Pipe Saddle Size Range: 2" thru 12" Page 108</p>	 <p>Fig. 191 Adjustable Pipe Saddle with U-Bolt Size Range: 2" thru 12" Page 108</p>
 <p>Fig. 258 Pipe Stanchion Saddle Size Range: 4" thru 36" Page 109</p>	 <p>Fig. 264 Adjustable Pipe Saddle Support Size Range: 2½" thru 36" Page 110</p>	 <p>Fig. 265 Adjustable Pipe Saddle Support with U-Bolt Size Range: 4" thru 36" Page 111</p>	 <p>Fig. 259 Pipe Saddle Support with U-Bolt Size Range: 4" thru 36" Page 112</p>

TRAPEZE

 <p>Fig. 46 Universal Trapeze Assembly Page 113</p>	 <p>Fig. 45 Channel Assembly Page 114</p>	 <p>Fig. 50 Equal Leg Angle for Trapeze Assembly Page 115</p>
---	---	---







PIPE SHIELDS & SADDLES

 <p>Fig. 167 Insulation Protection Shield Size Range: ½" thru 24" pipe with up to 2" thick insulation Page 116</p>	 <p>Fig. 168 Rib-Lok Shield Size Range: ½" thru 8" pipe or copper tube with up to 2" thick insulation Page 117</p>	 <p>Fig. 160 to 166A Pipe Covering Protection Saddle Size Range: ¾" thru 36" Pages 118 - 121</p>
--	--	--



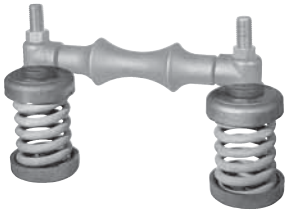

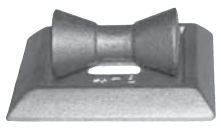
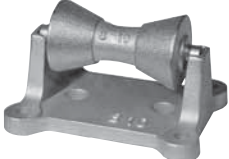

PICTORIAL TABLE OF CONTENTS

Pipe Rolls – Pipe Guides & Slides

PIPE ROLLS

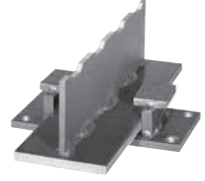
 <p>Fig. 177 Adjustable Pipe Roll Support Size Range: 1" thru 30" Page 122</p>	 <p>Fig. 171 Single Pipe Roll Size Range: 1" thru 30" Page 123</p>	 <p>Fig. 178 Spring Cushion Hanger Page 124</p>	 <p>Fig. 181 Adjustable Steel Yoke Pipe Roll Size Range: 2 1/2" thru 24" Page 125</p>
 <p>Fig. 175 Roller Chair Size Range: 2" thru 30" pipe Page 126</p>	 <p>Fig. 277 Pipe Roll and Base Plate Size Range: 2" thru 24" Page 127</p>	 <p>Fig. 271 Pipe Roll Stand Size Range: 2" thru 42" Page 128</p>	 <p>Fig. 274, 274P & 275 Adjustable Pipe Roll Stand Size Range: 2" thru 42" Page 129</p>

PIPE GUIDES & SLIDES

 <p>Fig. 255 Pipe Alignment Guide Size Range: 1" thru 24" pipe and insulation thickness of 1" thru 4" Pages 130 - 131</p>	 <p>Fig. 256 Pipe Alignment Guide Size Range: 1" thru 24" pipe and insulation thickness of 1" thru 4" Pages 132 - 133</p>	 <p>Fig. 257 & 257A Structural Tee Slide Assembly Size Range: All sizes within maximum load rating Pages 134 - 137</p>	 <p>Fig. 436 & 436A Fabricated Tee Slide Assembly Size Range: All sizes within maximum load rating Pages 134 - 137</p>
 <p>Fig. 439 & 439A Structural "H" Slide Assembly, Complete Size Range: 6" thru 36" Pages 138 - 139</p>	 <p>Fig. 432 Special Clamp Size Range: 2" thru 24" Page 140</p>	 <p>Fig. 212 Medium Pipe Clamp Size Range: 2" thru 30" Page 141</p>	





PICTORIAL TABLE OF CONTENTS

Sway Brace - Seismic (Go to www.anvilintl.com/Product/SeismicSwayBracing.aspx for current Product Data Sheets)

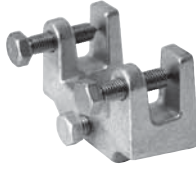

PIPE BRACE CLAMPS **NEW**

  <p>Fig. 770 Q Brace Clamp Size Range: 1" thru 6" Service Pipe</p>	  <p>Fig. 776 Brace Clamp Size Range: 2 1/2" thru 8" Service Pipe</p>	  <p>Fig. 775 Lateral/Longitudinal Brace Clamp Size Range: 2 1/2" thru 8" Service Pipe</p>
--	--	---



STRUCTURAL ATTACHMENTS **NEW**

  <p>Fig. 778 Bar Joist and Beam Attachment (WF) Size Range: Flange Thickness 1/8" thru 3/4"</p>	  <p>Fig. 772 Adjustable Steel Beam Attachment Size Range: Flange Widths 4" thru 15"</p>	  <p>Fig. 779 Multi-Connector Adapter Size Range: 1" thru 8" Service Pipe</p>
--	---	---

RESTRAINTS **NEW**

  <p>Fig. 773 Surge Restrainer Size Range: 3/4" thru 2" Swivel Ring Hanger</p>	  <p>Fig. 777 Swivel Joint Connector - Rod Tap Size Range: 3/8" Rod Diameter</p>
---	---

SWAY BRACE ATTACHMENT **NEW**

  <p>Fig. 771 Sway Brace Swivel Attachment Size Range: 1" and 1 1/4" Brace Pipe</p>
--

Pictorial Table of Contents

General Notes

Copper Tubing Hangers

CPVC Pipe Hangers

Pipe Rings

Clevis Hangers

Steel Pipe Clamps

Socket Clamps

Beam Clamps

Structural Attachments

Brackets

Ceiling Plates & Flanges

Concrete Inserts & Attachments

Hanger Rods

Rod Attachments

Bolts, Nuts, Pins & U-Bolts

PICTORIAL TABLE OF CONTENTS

Spring Hangers — Snubbers

SPRING HANGERS



Fig. 82 & C-82
Short Spring
Pages 142 - 143,
152 - 153



Fig. B-268 & C-268
Standard Spring
Pages 142 - 143,
147 - 151



Fig. 98 & C-98
Double Spring
Pages 142 - 143,
154 - 155

Triple Spring, Triple Spring-CR
Pages 156 - 157

Quadruple Spring, Quadruple Spring-CR
Pages 158 - 159

HORIZONTAL TRAVELER & SWAY BRACE



Fig. 170
Horizontal Traveler
Size Range: Available in four sizes to take loads to 20,700 (lbs.)
All sizes provide for 12" of horizontal travel.
Page 184

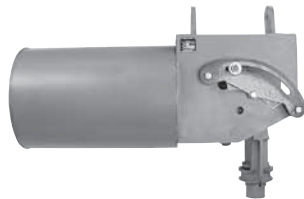

Fig. 296, 297, 298, 301, 302, 303
Sway Brace
Size Range: Preloads from 50 (lbs.) to 1,800 (lbs.) and maximum forces
from 200 (lbs.) to 7,200 (lbs.)
Pages 185 - 187

CONSTANT SUPPORTS



Model R Fig. 80-V
Vertical Constant Support
Pages 168 - 174



Model R Fig. 81-H
Horizontal Constant Support
Pages 175 - 181

SWAY STRUT ASSEMBLY



Fig. 211, C-211, 640, C-640
Sway Strut Assembly
Pages 188 - 189

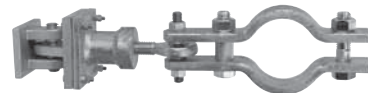

Fig. 222 & C-222
Mini-Sway Strut Assembly
Pages 190 - 191

SNUBBERS



Fig. 3306 & 3307
Hydraulic Shock and Sway Suppressor (Snubber)
Size Range: Seven standard sizes with
load ratings from 350 (lbs.) to 120,000 (lbs.)
Pages 192 - 195

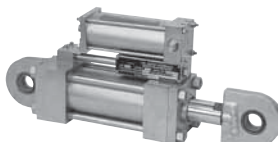

Fig. 200, C-200, 201, C-201
Hydraulic Shock and Sway Suppressor (Snubber)
Size Range: Nine standard sizes with
load ratings from 3000 (lbs.) to 128,000 (lbs.)
Pages 197 - 199



Fig. 312
Tapered Pin
Size Range: 3/8" thru 2 1/2"
Page 200

Standard Materials

Anvil catalog items are made from the following materials.

Hanger Classification	Material	Material Specifications (ASTM)
Beam Clamps	Malleable Iron	A197
	Ductile Iron	A536-77 Grade 65-45-12
	Carbon Steel - Stamped	A36 or A1011, CS, Type A, B, or C
	Carbon Steel- Formed	A575 Grade M1020
	Forged Steel	A668 or A1030
Bolts, Nuts, Pins and U-Bolts	Carbon Steel - Rod	A36 or AISI 1006-1015
	Carbon Steel - Bolts	A307
	Carbon Steel- Nuts	A563
Brackets	Malleable Iron	A197
	Carbon Steel - Pre Galv.	A653
	Carbon Steel - Structural Shapes and Plate	A36
Ceiling Plates and Flanges	Plastic	N/A
	Malleable Iron	A197
Clevis Hangers	Carbon Steel - Stamped	A1011, CS, Type A, B or C
Clevis Hangers - Pipe or Conduit	Carbon Steel	A569 Grade 1008-1010 or A525 or A526
Clevis Hangers - Ductile Iron Pipe	Carbon Steel	A36, A569
Concrete Inserts and Attachments	Malleable Iron	A197
	Carbon Steel - Stamped	A1011
	Carbon Steel - Formed and Fabricated	A36 or A515 Grade 65-70
Copper Tubing Hangers	Malleable Iron	A197
	Carbon Steel	A1011, CS, Type A, B or C
Copper Tubing Hangers - Pipe Ring	Carbon Steel	A653
CPVC Hangers	Carbon Steel	A1011, CS, Type B
Hanger Rods	Carbon Steel	A36 or A1006-1015
Pipe Alingment Guides	Carbon Steel	A36 or A1011, CS, Type A, B, or C
Pipe Slides	Carbon Steel - Structural Shapes or Plates	A36
Pipe Rings	Malleable Iron	A197
	Carbon Steel	A653
Pipe Roll - (2) Rod, Yoke & Chair	Cast Iron	A1010 or A1015
Pipe Roll - Stands	Cast Iron	A48 Gr 20 or A126
Pipe Protection Saddles	Carbon Steel	A36 or A1011, CS, Type A, B, or C
	Alloy Steel	A387 Grade 22 Class 1 Annealed
Pipe Shields	Carbon Steel	A653
Pipe Supports - Stanchions	Carbon Steel	Tube: A513 Grade 1020 or 1026, Plate:A36
Pipe Supports - Saddles	Carbon Steel	A36
	Cast Iron	A48 Grade 20 or A126
Rod Attachments	Malleable Iron	A197
	Carbon Steel	A36
	Forged Steel	A668 or A1030
Rod Attachments - Rod Couplings	Carbon Steel	A307 or A563
Socket Clamps	Carbon Steel	A36
Socket Clamps- Washers	Cast Iron	A126
	Carbon Steel	A36
Stainless Steel Hangers and Supports	Refer to table note 1.	
Plate	Stainless Steel	A240 Type 304
Pipe	Stainless Steel	A312 Type 304
Rod and Pins	Stainless Steel	A276 Type 304
Bolts	Stainless Steel	18-8 Stainless
Nuts	Stainless Steel	18-8 Stainless
Steel Pipe Clamps- Offset and Extended	Carbon Steel	A36 or A570 Grade C/D or AISI 1020
	Carbon Steel - Stamped	A36 or A1011, CS, Type A, B, or C
Steel Pipe Clamps	Carbon Steel - Formed	A36 or A515 Grade 65-70
	Chrome Molybdenum Steel	A387 Grade 22
	Malleable Iron	A197
Straps	Carbon Steel - Formed	A36
	Carbon Steel - Stamped	A1011, CS, Type A, B, or C
Structural Attachments - Washer Plates	Carbon Steel	A36 or AISI 1020 or A515 Grade 65-70
Structural Attachments	Carbon Steel	A36 or A515 Grade 65-70
	Malleable / Ductile	A197, A536-77 Grade 65-45-12
Trapeze	Carbon Steel - Structural Shapes	A36
	Carbon Steel - HSS	A500 Grade B or C

- Notes: 1. Most Anvil hanger figure numbers are available in stainless steel on special order, primarily in type 304 and type 316. Items are limited.
 2. Custom fabricated products can be furnished - to specifications provided by customer.
 3. Standard material specifications are subject to change without notice.

Standard Galvanizing Practice

Anvil offers 3 basic forms of zinc coating on its hanger components

1) Electro-Plated Zinc (Electro-galvanized)

2) Pre-Galvanized Zinc

3) Hot Dipped Galvanized

Note: The corrosion resistance of zinc is based on its thickness, the environment and the coating process used.

Electro-Plated Zinc (ASTM B633)

This type of coating is recommended for use indoors in relatively dry areas. The steel is submerged in a bath of zinc salts, through the process of electrolysis, a coating of pure zinc adheres to the steel with a molecular bond. A maximum of .5 mills of zinc can be applied using this method. The threaded components and fasteners for Anvil hangers are furnished electro-plated.

Pre-Galvanized Zinc (ASTM A653)

This type of coating is suitable for extended exposure in dry or mildly corrosive atmospheres, but not generally recommended for use outdoors in industrial environments. Also known as "mill galvanized" or "hot-dipped mill galvanized", pre-galvanized zinc coatings are produced by rolling the steel coils or sheets through molten zinc at the steel mill. The material is then cut or slit to size. Coating thickness is .90 ounces per square foot of steel surface. Zinc near the uncoated edges or weld areas becomes a sacrificial anode which protects the bare areas. Anvil uses this type of material on our Fig. 167 shields and Fig. 69 swivel ring hangers.

Hot-Dip Galvanized (ASTM 123 or ASTM 153)

Recommended for prolonged outdoor exposure and will usually protect steel in most atmospheric environments. After fabrication, the part is immersed in a bath of molten zinc. A metallurgical bond is formed, resulting in a zinc coating that coats all surfaces including edges. Anvil's standard galvanizing practice for our Fig. 261 riser clamps and Fig. 212 medium pipe clamps is hot-dip galvanized.

Standard Galvanizing Practice (cont.)

Figure Number	Description	Standard Galvanize Finish
14	Adj. Side Beam Clamp	EG
40	Riser Clamp – Standard	Hot Dip with EG Fasteners
45	Channel Assembly	Hot Dip
46	Universal Trapeze Assembly	Hot Dip
47	Concrete Single Lug Plate	Hot Dip
49	Concrete Clevis Plate	Hot Dip with EG Fasteners
50	Equal Leg Angle for Trapeze Assembly	Hot Dip
52	Concrete Rod Attachment Plate	Hot Dip
54	Two Hole Welding Beam Lug	Hot Dip
55	Structural Welding Lug	Hot Dip
60	Steel Washer Plate	Hot Dip
62	Pipe Stanchion	Hot Dip
63	Pipe Stanchion	Hot Dip
65	Light Duty Adj. Clevis	EG
66	Welded Beam Attachment	Hot Dip
66 with BN	Welded Beam Attachment	Hot Dip with EG Fasteners
67	Pipe or Conduit Hanger	EG
69	Adj. Swivel Ring, Tapped per NFPA Standards	Strap is Pre-Galv. Material, Nut is EG
76	Fabricated Roller for Large Dia. Pipe	Galvanizing not possible, Paint Only
86	C-Clamp with Set Screw & Lock Nut	EG
88	C-Clamp with Set Screw	EG
89, 89X	Retaining Clip	EG
92	Universal C-Type Clamp (Std. Throat)	EG
93	Universal C-Type Clamp (Wide Throat)	EG
94	Wide Throat Beam C-Clamp	EG
95	C-Clamp with Lock Nut	EG
100	Extended Pipe Clamp	Hot Dip with EG Fasteners
103	Offset Pipe Clamp	Hot Dip with EG Fasteners
104	Adj. Swivel Ring, Split Ring Type	EG
120	Light Weight U-Bolt	EG
126	One-Hole Clamp	EG
128R	Rod Threaded Ceiling Flange	EG
133	Standard Duty Beam Clamp	Hot Dip with EG Fasteners
134	Heavy Duty Beam Clamp	Hot Dip with EG Fasteners
135E	Rod Coupling Straight less Sight Hole	EG
135R	Rod Coupling Reducing	EG
136	Rod Coupling Straight	EG
136R	Rod Coupling Reducing	EG
137	Standard U-Bolt	EG
137S	Special U-Bolt (non-standard)	Hot Dip
138R	Ext. Split Pipe Clamp (Rod Threaded)	EG
140	Machine Threaded Rod (RH Threads)	EG
142	Coach Screw Rod	EG
146	Continuous Threaded Rod	EG
148	Rod with Eye End	EG
157	Extension Piece	EG
167	Insulated Protection Shield	Pre-Galv. Material
168	Rib-Lok Shield	Pre-Galv. Material
171	Single Pipe Roll	EG
175	Roller Chair	Chair-Hot Dip, All Other EG
177	Adj. Pipe Roll Support	EG
178	Spring Cushion Hanger	Can Galv. Retainer, Springs Paint Only
181	Adj. Steel Yoke Pipe Roll	Hot Dip Yoke, All Other EG
185	One Hole Pipe Strap	EG
186	Two Hole Pipe Strap	EG
187	Two Hole 90° Side Mount Strap	EG
188	Two Hole Stand Off Strap	EG
189	Straight Eye Socket	Pre-Galv.
190	Off-Set Eye Socket	Pre-Galv.
191	Adj. Pipe Saddle with U-Bolt	EG
192	Adj. Pipe Saddle	EG
194	Light Welded Steel Bracket	Hot Dip
195	Medium Welded Steel Bracket	Hot Dip
199	Heavy Welded Steel Bracket	Hot Dip

Figure Number	Description	Standard Galvanize Finish
202	Iron Side Beam Bracket	Hot Dip
206	Steel Side Beam Bracket	EG
207	Threaded Steel Side Beam Bracket	EG
212	Medium Pipe Clamp	Hot Dip with EG Bolts & Nuts
212FP	Earthquake Bracing Clamp	Hot Dip with EG Bolts & Nuts
216	Heavy Pipe Clamp	Hot Dip with EG Bolts & Nuts
218	Malleable Beam Clamp without Ext. Piece	EG
228	Universal Forged Steel Beam Clamp	EG
230	Turnbuckle	EG
233	Turnbuckle	EG
248, 248L, 248X	Eye Rod Not Welded	EG
253	Machine Threaded Rod (Threaded Both Ends)	EG
255	Pipe Alignment Guide	Hot Dip with EG Bolts & Nuts
CT-255	Copper Tubing Alignment Guide	Housing: Hot Dip with EG Bolts & Nuts Spider Clamp: Copper Plated
256	Pipe Alignment Guide	Hot Dip with EG Bolts & Nuts
257	Structural Tee Slide	Hot Dip, Weld after Galv. & Cold Spray Touch-up
258	Pipe Saddle Support	EG
259	Pipe Saddle Support with U-Bolt	EG
260	Adj. Clevis Hanger	8" & Smaller: EG 10" & Larger: Hot Dip with EG Bolts & Nuts
260 ISS	Clevis Hanger with Insulation Saddle System	Reference Fig. 260
261	Ext. Pipe or Riser Clamp	Hot Dip with EG Bolts & Nuts
262	Strap Short	EG
264	Adj. Pipe Saddle Support	EG
265	Adj. Pipe Saddle Support with U-Bolt	EG
271	Pipe Roll Stand	EG
274	Adj. Pipe Roll Stand with Base Plate	EG
274P	Pipe Roll Stand - Base Plate Only	EG
275	Adj. Pipe Roll Stand without Base Plate	EG
277	Pipe Roll and Base Plate	EG
278, 278L, 278X	Eye Rod Welded	EG
281	Wedge Type Concrete Insert	EG
282	Universal Concrete Insert	EG
285	Light Weight Concrete Insert	EG
290, 290L	Weldless Eye Nut	EG
291	Clevis Pin with Cotters	EG
292, 292L	Universal Forged Steel Beam Clamp	EG
295	Double Bolt Pipe Clamp	Hot Dip with EG Bolts & Nuts
295A	Alloy Double Bolt Pipe Clamp	Alloy Material, Galv. is not Recommended
295H	Heavy Duty Double Bolt Pipe Clamp	Hot Dip with EG Bolts & Nuts
299	Forged Steel Clevis	EG
300	Adj. Clevis for Insulated Lines	8" & Smaller: EG 10" & Larger: Hot Dip with EG Bolts & Nuts
395	Cast Iron Ceiling Plate	EG
432	Special Clamp	Hot Dip with EG Bolts & Nuts
436	Fabricated Tee Slide Assembly	Hot Dip, Weld after Galv. & Cold Spray Touch-up
439	Structural "H" Slide Assembly	Hot Dip, Weld after Galv. & Cold Spray Touch-up
590	Adj. Clevis for Ductile or Cast Iron Pipe	Hot Dip with EG Bolts & Nuts
594	Socket Clamp Washer	EG
595	Socket Clamp for Ductile Iron or Cast Iron Pipe	Hot Dip with EG Bolts & Nuts
599	Socket Clamp Washer	EG
600	Socket Clamp for Ductile Iron or Cast Iron Pipe	Hot Dip with EG Bolts & Nuts

EG = Zinc Electro Plate ASTM B633 Hot Dip = ASTM A123 or A153 Pre-Galv. = ASTM A653
Most EG items can be hot dip galvanized. Hot dip fasteners are available as is all thread rod.

COPPER TUBING HANGERS

Fig. CT-69

Adjustable Swivel Ring

Size Range: 1/2" through 4"

Material: Carbon steel

Finish: Copper plated

Service: Recommended for suspension of non-insulated **stationary** copper tube.

Approvals: Complies with Federal Specification A-A-1192A (Type 10)

WW-H-171-E (Type 10), ANSI/MSS SP-69 and MSS SP-58 (Type 10).

Features:

- Threads are countersunk so that they cannot become burred or damaged.
- Knurled swivel nut provides vertical adjustment after piping is in place.
- Captured swivel nut will not fall off.

Ordering: Specify nominal tube size, figure number, name and finish.

Note: Metric nut available upon request.

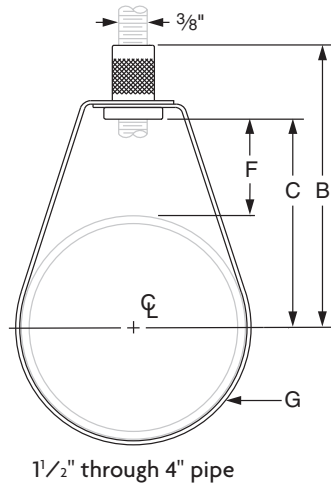
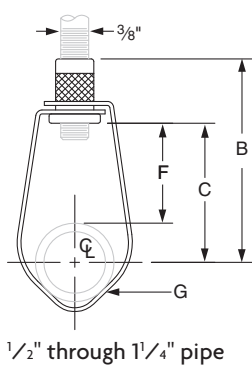

FIG. CT-69: LOADS (LBS) • WEIGHT (LBS) • DIMENSIONS (IN)

Tube Size	Max Load	Weight	B	C	F	G Width
1/2	300	0.10	3	2 ³ / ₁₆	1 ⁷ / ₈	5/8
3/4		0.10	2 ¹³ / ₁₆	2	1 ⁹ / ₁₆	
1		0.10	2 ¹¹ / ₁₆	1 ¹³ / ₁₆	1 ¹ / ₄	
1 1/4		0.10	2 ¹ / ₂	1 ⁵ / ₈	1 ⁵ / ₁₆	
1 1/2		0.10	2 ¹¹ / ₁₆	1 ¹³ / ₁₆	1	
2	525	0.11	3 ⁷ / ₁₆	2 ¹ / ₂	1 ¹ / ₂	3/4
2 1/2		0.25	3 ¹³ / ₁₆	2 ¹⁵ / ₁₆	1 ¹¹ / ₁₆	
3		0.27	4 ¹ / ₄	3 ³ / ₈	1 ⁷ / ₈	
4		0.48	4 ³ / ₈	3 ¹ / ₂	1 ¹ / ₂	

Note: Reflects changes in rod diameter from previously published data per recent revisions in MSS-SP-58 & 69

Fig. CT-65

Light Duty Adjustable Clevis

Size Range: 1/2" through 4"

Material: Carbon steel

Finish: Copper plated

Service: Recommended for suspension of non-insulated, **stationary** copper tube.

Approvals: Complies with Federal Specification WW-H-171-E (Type 12).

Installation:

- (1) Adjustment may be made either before or after tubing is in place without temporary support of pipe.
- (2) Hanger rod and nuts may be locked into position after adjustment by use of the upper nut.

Features: Provides for adjustment up to 1 7/8".

Ordering: Specify nominal tube size, figure number, name and finish

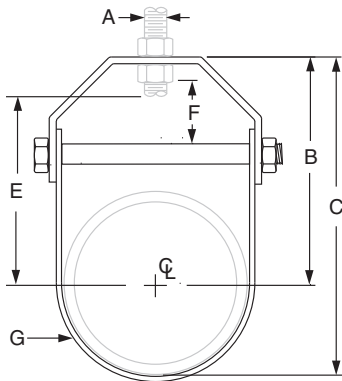
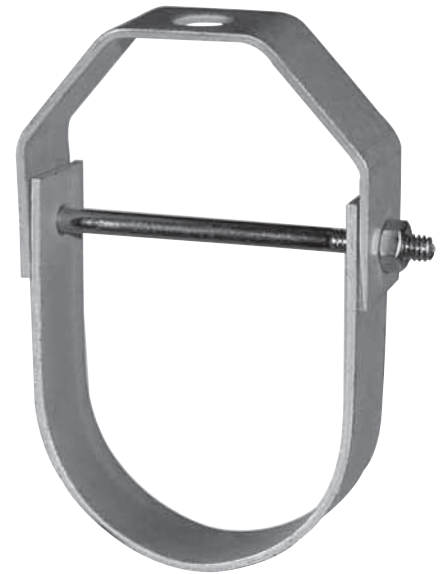

FIG. CT-65: LOADS (LBS) • WEIGHT (LBS) • DIMENSIONS (IN)

Tube Size	Max Load	Weight	Rod Size A	B	C	D	Rod Take Out - E	Adjustment F	G Width Lower
1/2	150	0.09	3/8	1 1/2	1 27/32	1 7/16	1 1/16	5/16	5/8
3/4		0.10		1 11/16	2 3/32	1 9/16	1 1/4	7/16	3/4
1	0.17	1 7/8		2 13/32	1 5/8	1 7/16	1/2		
1 1/4	250	0.18		2 5/32	2 13/16	1 3/4	1 11/16	5/8	
1 1/2		0.21		2 17/32	3 3/8	1 15/16	2 1/16	13/16	
2	350	0.26		3 11/32	4 17/32	2 5/16	2 7/8	1 3/16	
2 1/2		0.48		3 27/32	5 9/32	2 3/4	3 1/4	1 5/16	
3		0.55		4 15/32	6 7/32	3	3 7/8	1 5/8	
4	400	0.60	4 31/32	6 31/32	3 1/4	4 3/8	1 7/8		

Note: 1) Reflects changes in rod diameter from previously published data per recent revisions in MSS-SP-58 & 69.

2) 3 1/2" tube size alternate - 3 1/2" Fig. 65 galvanized.

COPPER TUBING HANGERS

Fig. CT-128R

Rod Threaded Ceiling Flange

Size Range: $\frac{3}{8}$ " and $\frac{1}{2}$ "

Material: Malleable iron

Finish: Copper plated

Service: Recommended for attachment to wood beams or ceiling.

Ordering: Specify rod size, figure number, name.

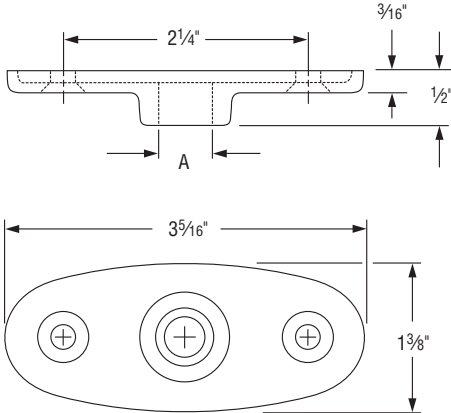

**FIG. CT-128R:
LOADS (LBS) • WEIGHT (LBS) • DIMENSIONS (IN)**

Rod Size A	Max Load	Weight	Screws	
			Quantity	Size No.
$\frac{3}{8}$	180	0.16	2	12
$\frac{1}{2}$				

Fig. CT-138R

Extension Split Tubing Clamp (Rod Threaded)

Size Range: $\frac{1}{2}$ " through 2"

Material: Malleable iron

Finish: Copper plated

Service: Recommended for suspension of non-insulated **stationary** copper tube.

Approvals: Complies with Federal Specification A-A-1192A (Type 12)

WW-H-171-E (Type 25), ANSI/MSS SP-69 and MSS SP-58 (Type 12).

Installation:

- Permanent installation of clamp may be made before the tubing is placed in position.
- Final installation is attained by swinging the lower portion of the hinged clamp up under the tubing and inserting a single screw securely.

Features:

- Hinged design provides for economical installation.
- Designed to provide a tight fit on copper tubing.

Ordering: Specify nominal tube size, figure number, name.

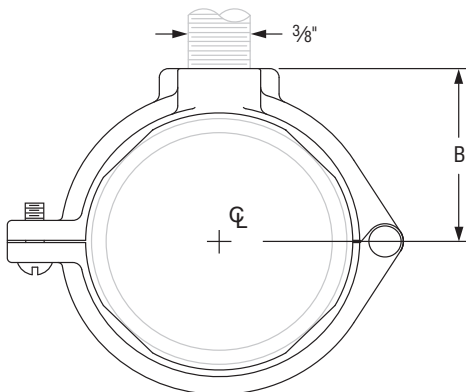

**FIG. CT-138R:
LOADS (LBS) • WEIGHT (LBS) • DIMENSIONS (IN)**

Tube Size	Max Load	Weight	B
$\frac{1}{2}$	180	0.10	$\frac{3}{4}$
$\frac{3}{4}$		0.12	$\frac{7}{8}$
1		0.14	1
$1\frac{1}{4}$		0.18	$1\frac{1}{8}$
$1\frac{1}{2}$		0.22	$1\frac{1}{4}$
2		0.36	$1\frac{9}{16}$

Fig. 69F NEW

Adjustable Swivel Ring, Felt Lined

Size Range: 1/2" through 6" copper tube

Material: Carbon steel and felt with adhesive backing

Finish: Galvanized

Service: Recommended for suspension of non-insulated **stationary** copper tubing.

Maximum Temperature: 120° F

Approvals: Complies with Federal Specification A-A-1192A (Type 10)

WW-H-171-E (Type 10), ANSI/MSS SP-69 and MSS SP-58 (Type 10).

Features:

- The layer of felt separates the copper tubing from the steel ring for electrolytic resistance and also minimizes noise and vibration.
- Threads are countersunk so they cannot become burred or damaged.
- Knurled swivel nut provides vertical adjustment after tubing is in place.
- The captured nut is permanent in the bottom portion of band, allowing the hanger to be opened during installation if desired, but not allowing the nut to fall out.

Ordering: Specify felt ring size, figure number and name.

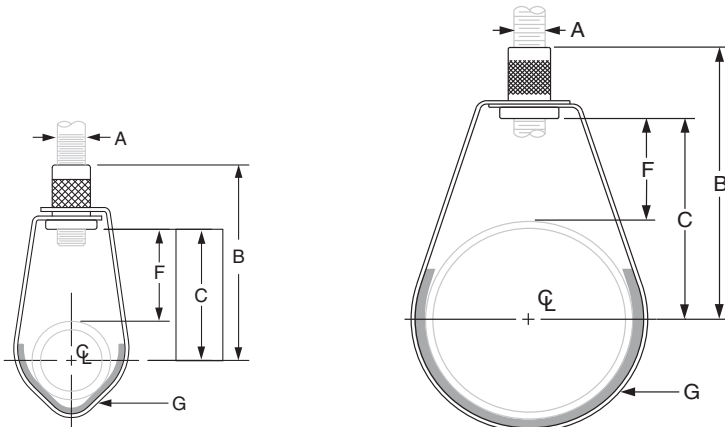

1/2" & 3/4" tube
1/2" through 1" Felted Ring

1" through 6" tube
1 1/4" through 6" Felted Ring

FELT LINED RING: IPS SIZING • DIMENSIONS (IN)	
Pipe Size	Felted Ring Size
1/2	1/2 - 1
3/4	1 1/4
1	1 1/4
1 1/4	2
1 1/2	2
2	2 1/2
2 1/2	3
3	4
4	5
5	6

FIG. 69F: LOADS (LBS) • WEIGHT (LBS) • DIMENSIONS (IN)								
Tube Size	Felted Ring Size	Max Load	Rod Size A	B	C	F	G Width	Weight
1/2	1/2 - 1	300	3/8	2 3/4	1 7/8	1 3/8	5/8	0.10
3/4				2 5/8	1 11/16	1 1/8		0.10
1	2 7/16			1 9/16	1 13/16	0.10		
1 1/4	2 1/2			1 5/8	1 3/16	0.10		
1 1/2	2 5/8			1 3/4	3/4	0.10		
2	3 1/8			2 1/4	1	0.10		
2 1/2	3 7/8	2 5/8	1/2	1 13/16	3/4	0.20		
3	3 3/4	2 7/8		0.20				
4	4 5/8	3 3/4		1 9/16		0.30		
5	5 1/4	4 5/16		1 5/8		0.54		
6	6 11/16	5 9/16		2 3/8		0.65		

COPPER TUBING HANGERS

Fig. 67F **NEW**

Copper Tube Felt Lined Hanger

Size Range: 1/2" through 6" copper tube

Material: Carbon steel and felt with adhesive backing

Finish: Galvanized

Service: Can be suspended by hanger rod or attached to wall. "T" slot in hanger permits side bolt to be installed after installation and setting of pipe.

Maximum Temperature: 120°F

Approvals: Complies with Federal Specification A-A-1192A (Type 5), ANSI/MSS SP-69 and MSS SP-58 (Type 5).

Features: The layer of felt separates the copper tubing from the steel strap for electrolytic resistance and also minimizes noise and vibration.

Components: Strap and bolt with nut – assembled.

Ordering: Specify felt hanger size, figure number and name.

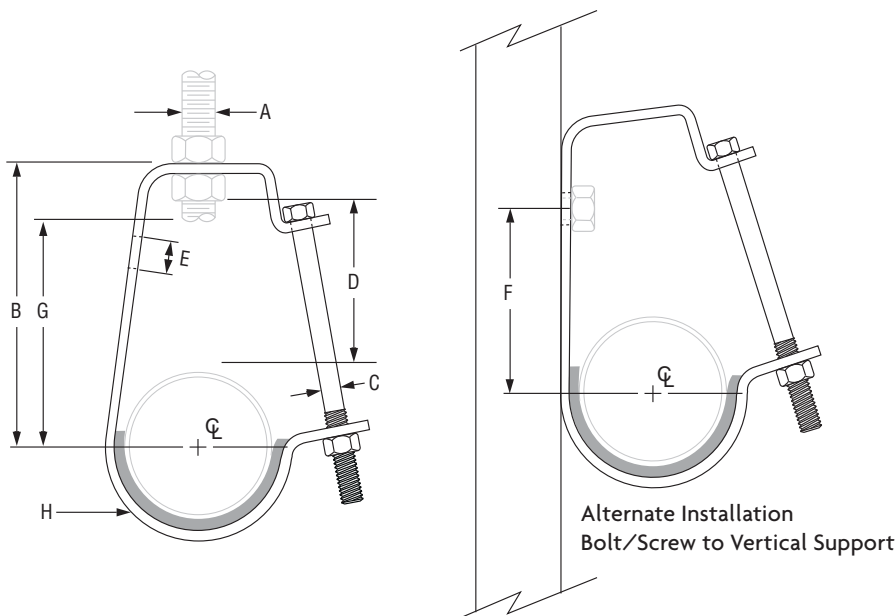

FELT LINED HANGER: IPS SIZING • DIMENSIONS (IN)

Pipe Size	Felted Hanger Size
3/4	1 1/4
1	1 1/2
1 1/4	2
1 1/2	2
2	2 1/2
2 1/2	3
3	4
4	5
5	6

FIG. 67F: LOADS (LBS) • WEIGHT (LBS) • DIMENSIONS (IN)

Tube Size	Felt Hanger Size	Load Rating	Rod Size A	B	C	D	E	F	G	H Width	Weight
1/2	3/4	400	3/8	2 1/2	1/4	1 5/8	7/16	1 5/16	1 3/4	1	0.22
3/4	1			2 11/16		1 11/16		1 5/8	1 5/16		0.25
1	1 1/4			2 13/16		1 13/16		2 1/8	2 1/8		0.27
1 1/4	1 1/4			3 1/8		1 7/8		2	2 9/16		0.27
1 1/2	1 1/2			3 7/16		2 1/16		2 5/16	2 3/4		0.29
2	2			3 3/16		2		2 7/16	2 5/16		0.31
2 1/2	2 1/2	500	1/2	4 5/16	3/8	2 5/16	9/16	3 1/16	3 1/2	1 1/4	0.71
3	3			4 3/4		2 1/2		3 1/2	4 1/16		0.78
4	4			6 1/16		3 1/8		4 5/8	5 3/16		1.39
5	5			6 11/16		3 3/16		5 1/8	5 13/16		1.66
6	6			7 3/4		3 3/16		5 15/16	6 3/4		2.26
				600		3/4					

Fig. CT-121

Copper Tubing Riser Clamp

Size Range: 1/2" through 4"

Material: Carbon steel

Finish: Copper plated

Service: Recommended for support and steadying of copper tube risers, either insulated or non-insulated. This product is not intended for use with hanger rods.

Approvals: Complies with Federal Specification A-A-1192A (Type 8), WW-H-171-E (Type 8), ANSI/MSS SP-69 and MSS SP-58 (Type 8).

Service: For support and steadying of copper tubing risers.

Installation: Clamp is fitted and bolted preferably below a coupling or fitting on the tubing. Do not over tighten bolts.

Features: Rounded ears provide greater safety for personnel.

Ordering: Specify tube size, figure number, name.

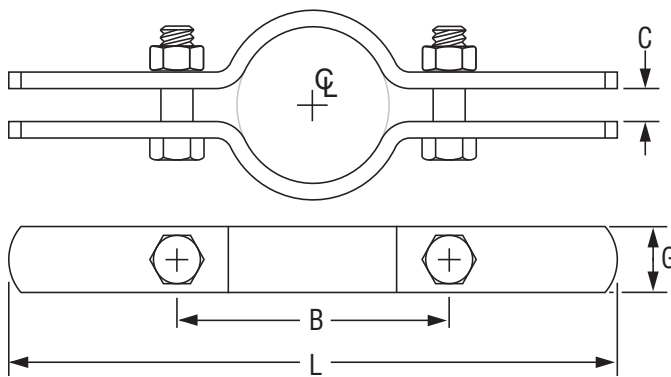

FIG. CT-121: LOADS (LBS) • WEIGHT (LBS) • DIMENSIONS (IN) • TORQUE (FT-LBS)

Tube Size	Max Load	Weight	L	G Width	Bolt Size	Torque Values
1/2	75	0.52	6 1/2	1	5/16	11
3/4		0.56	7			
1	120	0.94	9 5/8	1 1/4	3/8	21
1 1/4		0.98	9 5/8			
1 1/2	150	1.50	10			
2		1.50	10 3/8			
2 1/2	300	1.70	11 13/16			
3		1.80	11 1/2			
3 1/2		1.90	12			
4		2.60	13	1	1/2	46

Note: Minimum loads per MSS SP only applicable to 1 1/4" and up.

Fig. CT-255

Copper Tubing Alignment Guide

Size Range: 1" through 4"

Material: Carbon steel

Finish: Plain or Galvanized housing with copper plated finish on spider clamp.

Service: For maintaining alignment of tubing through its axial expansion and contraction cycles. Normally, two or more pipe alignment guides are used on a single tubing run to avoid a pivoting effect within the tubing system. Consult the Expansion Joint Manufacturers Association or the Copper Tube Manufacturers for additional guidelines of spacing requirements of intermediate guides. Supports are usually required between intermediate guides to comply with standard support practices.

Maximum Temperature: 400° F

Installation:

- (1) Attach outer housing to structure by bolting or welding.
- (2) Remove upper section of housing to open position.
- (3) Attach spider clamp to tube and completely insulate.
- (4) Set tube and spider clamp into outer housing.
- (5) Replace upper section of housing to closed position and secure.

Note: Spider attachments to tube must be properly located during installation to insure that a minimum of one-half the spider width remains within the length of the outer housing for all conditions of operation. If larger travels are required, special guides can be furnished to special order.

How to size: Size by nominal tube size and insulation thickness in accordance with the selection table.

Ordering: Specify size number, tube size, insulation thickness, figure number, name and finish.

Caution: The primary function of the Figure CT-255 is to maintain axial alignment of a system. Other components should be incorporated into the system to carry the primary loading of the system. Guides are designed such that minor loading amounts may be transferred to the guide in any given direction, up to 20% of dead weight load for typical maximum spans of a given pipe diameter.

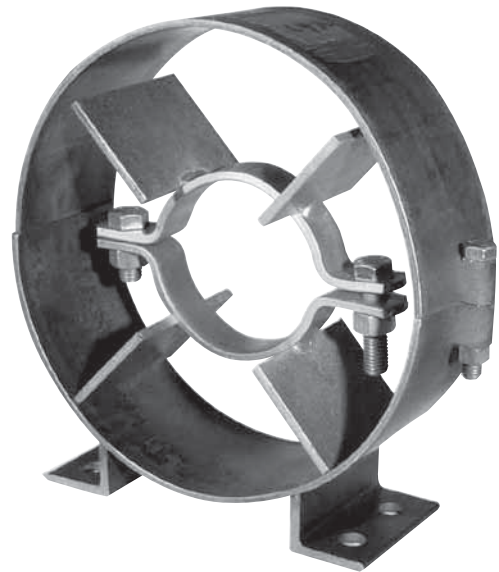

Tube Size (in)	L (in)	Maximum Movement
1" to 4"	4	4

Fig. CT-255

Copper Tubing Alignment Guide (cont.)

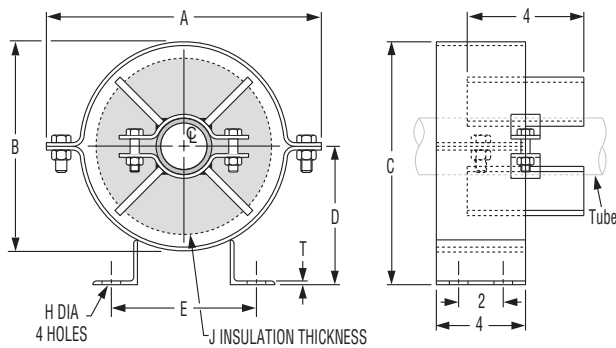

Copper Tubing Alignment Guide, Figure CT-255, Size A & B

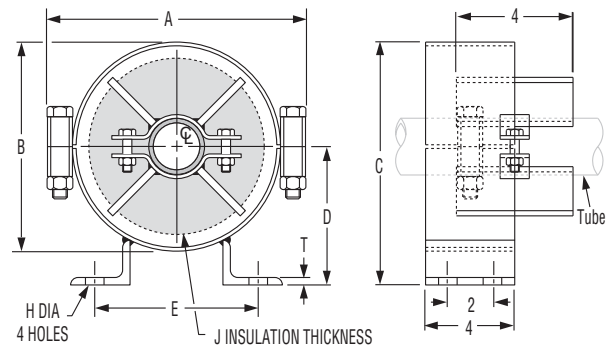

Copper Tubing Alignment Guide, Figure CT-255, Size C thru D

Guide Size No.	Dimensions (in)						
	A	B	C	D	E	H	T
A	8 ¹³ / ₁₆	6 ³ / ₄	8	4 ⁵ / ₈	5 ³ / ₄	5 ⁵ / ₈	1 ¹ / ₄
B	10 ¹³ / ₁₆	8 ³ / ₄	10	5 ⁵ / ₈	7		
C	13 ⁵ / ₁₆	11 ¹ / ₄	12 ⁷ / ₁₆	6 ⁵ / ₈	7 ³ / ₄		
D	15 ⁵ / ₈	13 ³ / ₈	14 ¹³ / ₁₆	7 ¹⁵ / ₁₆	9 ³ / ₄		

Tube Size	Guide Size Number					
	Insulation Thickness (in)					
	1	1½	2	2½	3	4
½	A	A	A	A	–	–
¾	A	A	A	A	–	–
1	A	A	A	A	C	C
1¼	A	A	A	C	C	C
1½	A	A	A	C	C	C
2	B	B	B	B	C	C
2½	B	B	B	B	C	C
3	B	B	B	B	D	D
3½	B	B	B	D	D	D
4	B	B	B	D	D	D

Fig. 185

One Hole Pipe Strap

Size Range: 3/4" through 2"

Finish: Galvanized steel

Service: Hanger for CPVC pipe in the horizontal position on the side of structural wood beams and Steel 20 Ga. (min) with hanger tab in the upward position only (Fig. A). It can also be used as a guide to limit movement of vertical CPVC pipe with the tab in the horizontal position.

Approvals: UL and ULC Listed.

Installation:

- Place hanger over pipe.
- Secure hanger to mounting surface with screws provided.
- Steel applications require one (1) #14 x 1" hex washer head self-drilling TEK screw. Not Supplied. Part Number STD-0090.

Features:

- Beveled edge design helps protect the CPVC pipe from any rough surface.
- Easily attaches to wood structure with #10 x 1" hex washer head self threading screw supplied with product. No pre-drilling required.

Ordering: Specify CPVC pipe size, figure number and description.

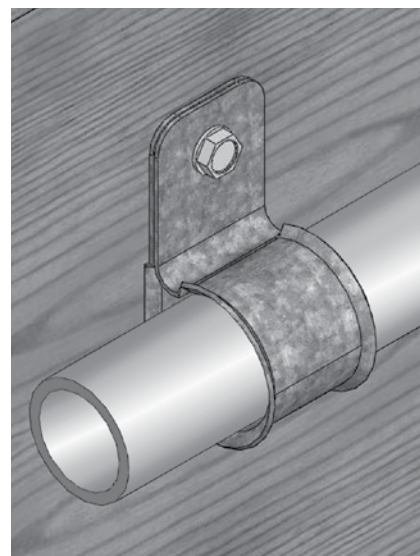
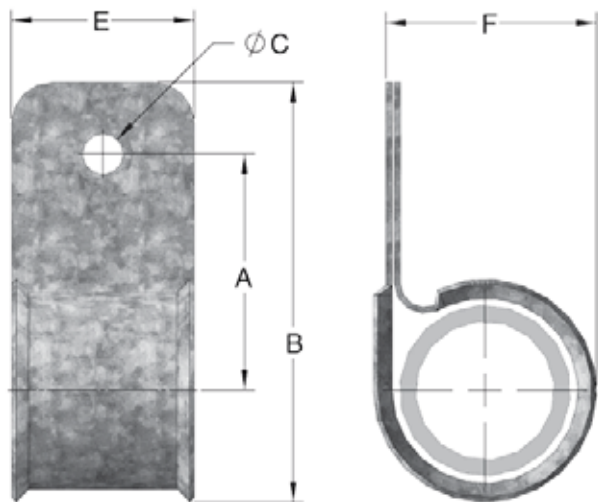

Fig. A

FIG. 185: WEIGHT (LBS) • DIMENSIONS (IN)

CPVC Pipe Size	A	B	ØC	E	F	Max. Hanger Spacing (FT.)	Approx. Weight/100 (lbs)
3/4	1 1/16	2 1/2	1/4	1 1/8	1 1/4	5 1/2	8
1	1 3/4	2 7/8	1/4	1 1/8	1 1/2	6	9
1 1/4	1 11/16	3	1/4	1 1/8	1 7/8	6 1/2	10
1 1/2	1 7/8	3 7/16	1/4	1 1/8	2 1/8	7	12
2	2	3 3/8	1/4	1 1/8	2 5/8	8	14

Fig. 186

Two Hole Pipe Strap

Size Range: 3/4" through 2"

Finish: Galvanized steel

Service: Hanger for CPVC pipe in the horizontal position on the bottom and side of structural wood beams, composite beams and Steel 20 Ga. (min.) (Fig. A, C respectively). Can be used as a restrainer when installed on top of structural wood beams (Fig. B), for limiting pipe movement due to thrust loads during sprinkler system start-up. It can also be used as a guide to limit movement for pipe in the vertical position. When used on composite wood beams, web thickness must be 3/8" or greater.

Approvals: UL and ULC Listed.

Installation:

- Snap hanger over pipe. Dimples will prevent hanger from falling off pipe.
- Secure hanger to mounting surface with screws provided.
- Do not make adjustments to hanger mounting flanges that result in clamping the pipe to the mounting surface. Pipe must be allowed to move freely through hanger.
- Steel applications require two (2) #14 x 1" hex washer head self-drilling TEK screws. Not Supplied. Part Number STD-0090.

Features:

- Dimples secure hanger to pipe for quick installation.
- Beveled edge design helps protect the CPVC pipe from any rough surface.
- Easily attaches to wood structure with #10 x 1" hex washer head self threading screw supplied with product. No pre-drilling required.

Ordering: Specify CPVC pipe size, figure number and description.

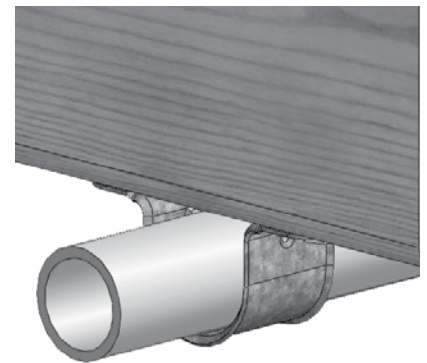

Fig. A

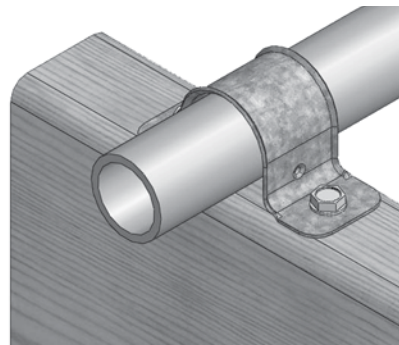

Fig. B

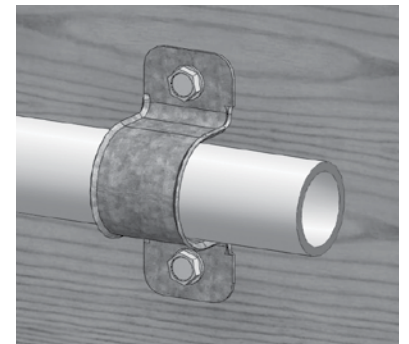

Fig. C

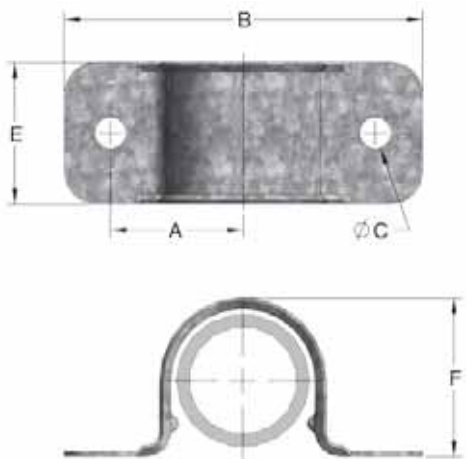

FIG. 186: WEIGHT (LBS) • DIMENSIONS (IN)

CPVC Pipe Size	A	B	ØC	E	F	Max. Hanger Spacing (FT.)	Approx. Weight/100 (lbs)
3/4	1	2 ¹ / ₁₆	1/4	1 ¹ / ₈	1 ¹ / ₈	5 ¹ / ₂	5
1	1 ¹ / ₄	3 ¹ / ₄	1/4	1 ¹ / ₈	1 ¹ / ₂	6	6
1 ¹ / ₄	1 ⁵ / ₁₆	3 ³ / ₈	1/4	1 ¹ / ₈	1 ¹¹ / ₁₆	6 ¹ / ₂	7
1 ¹ / ₂	1 ⁹ / ₁₆	3 ⁷ / ₈	1/4	1 ¹ / ₈	2 ¹ / ₈	7	8
2	1 ¹³ / ₁₆	4 ⁵ / ₁₆	1/4	1 ¹ / ₈	2 ⁹ / ₁₆	8	9

Fig. 187

Two Hole 90° Side Mount Strap

Size Range: 3/4" through 2"

Finish: Galvanized steel

Service: Hanger for CPVC pipe in the horizontal position on the bottom of structural wood beams and Steel 20 Ga. (min.) (Fig. A). *Can be used as a restrainer, only in Steel 20 Ga. (min.) (Fig. B).* During installation, adjust hanger mounting flanges such that pipe contacts both mounting surface and hanger, minimizing vertical pipe movement.

Approvals: UL and ULC Listed.

Installation:

- Snap hanger over pipe. Dimples will prevent hanger from falling off pipe.
- Secure hanger to mounting surface with screws provided.
- Do not anchor tightly to mounting surface. Pipe must be allowed to move freely through hanger.
- Steel applications require two (2) #14 x 1" hex washer head self-drilling TEK screws. Not Supplied. Part Number STD-0090.

Features:

- Beveled edge design helps protect the CPVC pipe from any rough surface.
- Easily attaches to wood structure with #10 x 1" hex washer head self threading screw supplied with product. No pre-drilling required.

Ordering: Specify CPVC pipe size, figure number and description.

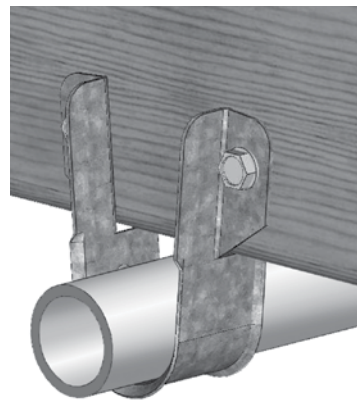
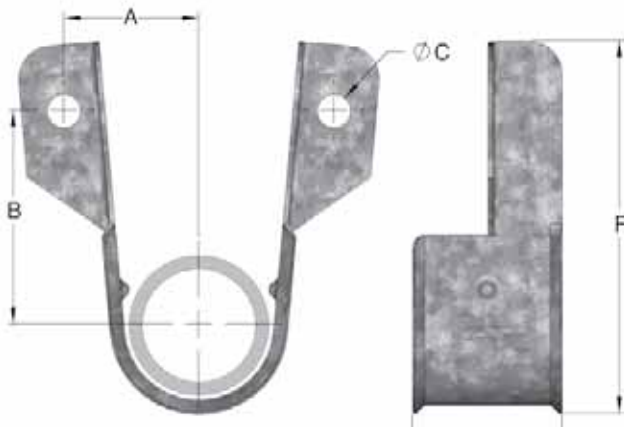

Fig. A

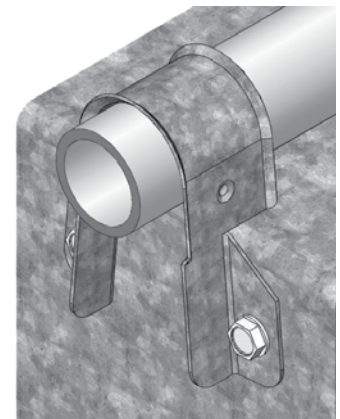

Fig. B

FIG. 187: WEIGHT (LBS) • DIMENSIONS (IN)

CPVC Pipe Size	A	B	øC	E	F	Max. Hanger Spacing (FT.)	Approx. Weight/100 (lbs)
3/4	1	1½	¼	1⅞	2¾	5½	5
1	1⅞	1½	¼	1⅞	2 ¹³ / ₁₆	6	6
1¼	1 ⁵ / ₁₆	1¾	¼	1⅞	3¼	6½	7
1½	1½	1⅞	¼	1⅞	3½	7	8
2	1¾	2	¼	1⅞	3 ⁷ / ₈	8	9

Fig. 188

Two Hole Stand Off Strap

Size Range: 3/4" through 2"

Finish: Galvanized steel

Service: Support for CPVC pipe off the face of structural wood beams (Fig. A) eliminates the use of back-up blocks. It can also be used as a hanger for CPVC pipe in the horizontal position on the bottom of structural wood beams and Steel 20 Ga. (min.) (Fig. B).

Approvals: UL and ULC Listed.

Installation:

- Snap hanger over pipe.
- Position hanger back around pipe but allow for pipe movement.
- Secure hanger to mounting surface with screws provided. Recheck to insure that the pipe is allowed to move freely through hanger.
- Steel applications require two (2) #14 x 1" hex washer head self-drilling TEK screws. Not Supplied. Part Number STD-0090.

Features:

- Beveled edge design helps protect the CPVC pipe from any rough surface.
- Easily attaches to wood structure with #10 x 1" hex washer head self threading screw supplied with product. No pre-drilling required.
- Eliminates wooden spacer blocks.

Ordering: Specify CPVC pipe size, figure number and description.

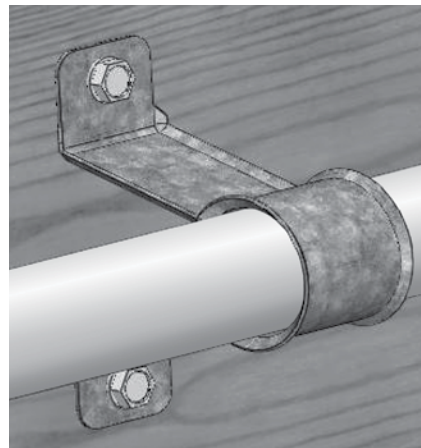
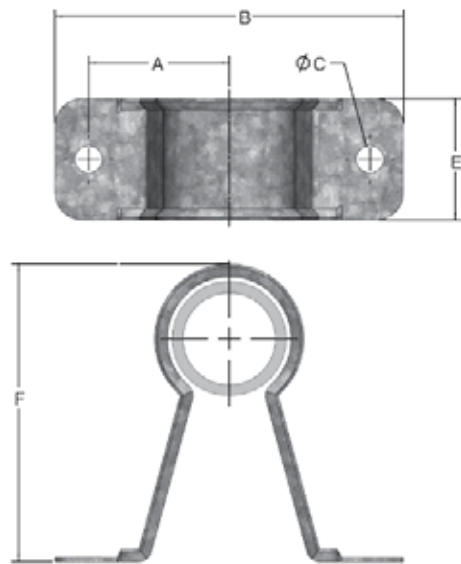

Fig. A

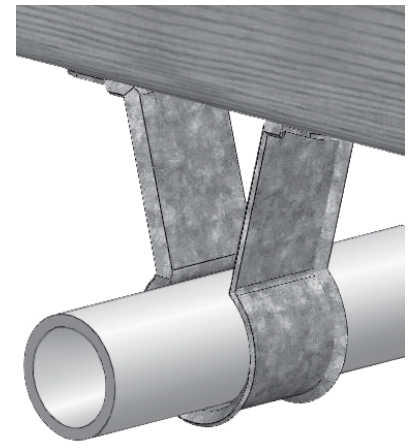

Fig. B

FIG. 188: WEIGHT (LBS) • DIMENSIONS (IN)

CPVC Pipe Size	A	B	øC	E	F	Max. Hanger Spacing (FT.)	Approx. Weight/100 (lbs)
3/4	1 5/16	3/4	1/4	1 1/8	2 3/4	5 1/2	5
1	1 3/8	3 3/8	1/4	1 1/8	3	6	6
1 1/4	1 1/2	3 1/16	1/4	1 1/8	3 5/16	6 1/2	7
1 1/2	1 7/8	4 3/8	1/4	1 1/8	3 3/16	7	8
2	2	4 1/2	1/4	1 1/8	4 1/8	8	9

- Pictorial Table of Contents
- General Notes
- Copper Tubing Hangers
- CPVC Pipe Hangers**
- Pipe Rings
- Clevis Hangers
- Steel Pipe Clamps
- Socket Clamps
- Beam Clamps
- Structural Attachments
- Brackets
- Ceiling Plates & Flanges
- Concrete Inserts & Attachments
- Hanger Rods
- Rod Attachments
- Bolts, Nuts, Pins & U-Bolts

Fig. 108

Split Pipe Ring

Size Range: $\frac{3}{8}$ " through 8"

Material: Malleable iron

Finish: Plain

Service: Recommended for suspension of non-insulated **stationary** pipe lines or conduit. May be used with rod socket Fig. 110R or turnbuckle adjuster Fig. 114.

Maximum Temperature: 450° F

Approvals: Complies with Federal Specification A-A-1192A (Type 11) WW-H-171-E (Type 11), ANSI/MSS SP-69 and MSS SP-58 (Type 11).

Features:

- Permits installation before or after pipe is in place.
- Provides economical installation.
- Permits use of universally adaptable parts.

Ordering: Specify pipe size, figure number, name.

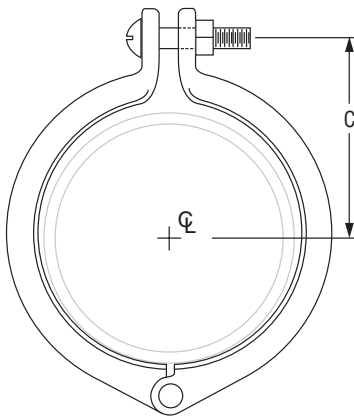

**FIGURE 108:
LOADS (LBS) • WEIGHT (LBS) • DIMENSIONS (IN)**

Pipe Size	Max Load	Weight	C	Bolt Size
$\frac{3}{8}$	200	0.06	$\frac{3}{4}$	#10 x $\frac{7}{8}$
$\frac{1}{2}$		0.09	$\frac{15}{16}$	
$\frac{3}{4}$	300	0.11	$1\frac{1}{8}$	
1		0.13	$1\frac{1}{4}$	
$1\frac{1}{4}$		0.18	$1\frac{9}{16}$	
$1\frac{1}{2}$		0.26	$1\frac{11}{16}$	
2	450	0.33	$2\frac{1}{16}$	$\frac{1}{4}$ x $1\frac{1}{4}$
$2\frac{1}{2}$		0.44	$2\frac{1}{4}$	
3		0.63	$2\frac{3}{4}$	
$3\frac{1}{2}$		0.81	$3\frac{1}{8}$	
4	520	0.97	$3\frac{5}{8}$	$\frac{3}{8}$ x 2
5		1.50	$4\frac{1}{2}$	
6	1,300	2.60	$5\frac{7}{16}$	$\frac{1}{2}$ x 2
8	1,800	5.20	$6\frac{3}{8}$	

Fig. 138R (Rod Threaded)

Extension Split Pipe Clamp

Size Range: $\frac{3}{8}$ " through 3"

Material: Malleable iron

Finish: Plain or Galvanized

Service: Recommended for non-insulated **stationary** pipe lines.

Maximum Temperature: 450° F

Approvals: Complies with Federal Specification A-A-1192A (Type 12) WW-H-171-E (Type 25), ANSI/MSS SP-69 and MSS SP-58 (Type 12).

Features:

- Rapid installation assured by hinged design and single closure screw.
- When used with nipple this clamp is particularly adaptive for use on refrigeration or compressor piping subject to vibration.
- Interior design provides firm grip on pipe.
- Inside of ring tapered to prevent entrapment of condensed moisture.

Ordering: Specify pipe size, figure number, name and finish.

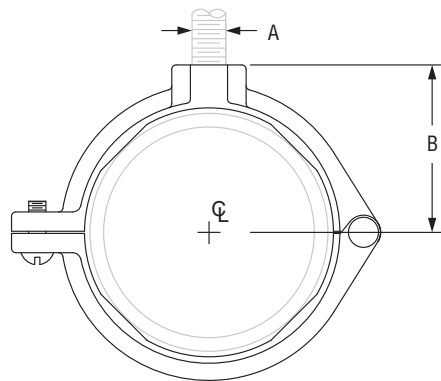

**FIG. 138R:
LOADS (LBS) • WEIGHT (LBS) • DIMENSIONS (IN)**

Pipe Size	Max Load	Weight	Rod Size A	B
$\frac{3}{8}$	180	0.10	$\frac{3}{8}$	$\frac{1}{16}$
$\frac{1}{2}$		0.13		$\frac{7}{8}$
$\frac{3}{4}$		0.14		1
1		0.16		$1\frac{1}{8}$
$1\frac{1}{4}$		0.22		$1\frac{5}{16}$
$1\frac{1}{2}$		0.24		$1\frac{7}{16}$
2		0.31		$1\frac{11}{16}$
$2\frac{1}{2}$	300	0.60	$\frac{1}{2}$	$2\frac{1}{8}$
3		0.74		$2\frac{7}{16}$

Fig. 104

Adjustable Swivel Ring, Split Ring Type

Size Range: 3/4" through 8"

Material: Malleable iron, carbon steel

Finish: Plain or Galvanized

Service: Recommended for suspension of non-insulated **stationary** pipe lines.

Maximum Temperature: 450° F

Approvals: Complies with Federal Specification A-A-1192A (Type 6) WW-H-171-E (Type 6), ANSI/MSS SP-69 and MSS SP-58 (Type 16).

Features:

- Labor-saving features in installation completely outweigh slight additional cost.
- Hanger may be installed prior to suspension of pipe.
- Off-center hinge provides seating for pipe during installation.
- Wedge-type locking pin is inseparably cast into hinged section, sizes 2 1/2" and larger.
- Adjustable swivel ring is self-locking; prevents loosening due to vibration; maintains proper pitch of pipe.
- Wire retaining ring prevents separation of swivel shank from pipe ring before installation.

Ordering: Specify pipe size, figure number, name and finish.

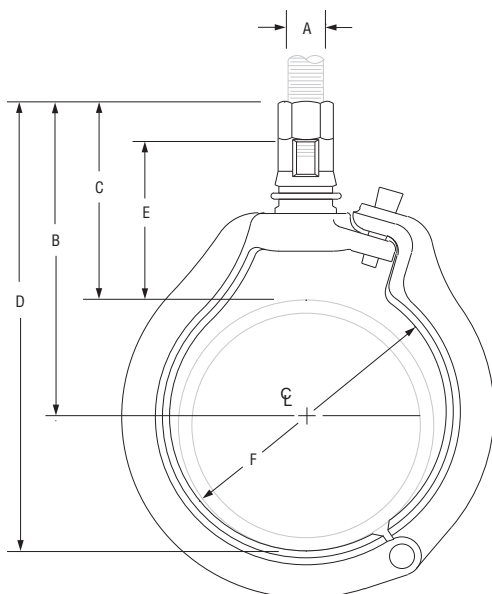

FIG. 104: LOADS (LBS) • WEIGHT (LBS) • DIMENSIONS (IN)

Pipe Size	Max Load	Weight	Rod Size A	B	C	D	E	Inside Dia. of Ring – F
3/4	300	0.31	3/8	2 7/8	2 3/8	3 7/16	1 15/16	1 3/16
1		0.32			2 1/4	3 9/16	1 3/4	1 7/16
1 1/4		0.34		3	2 3/16	3 7/8	1 11/16	1 13/16
1 1/2		0.41		3 3/8		4 1/8		2 1/16
2		0.48		3 1/2	2 5/16	4 11/16	1 13/16	2 1/2
2 1/2	500	0.58	1/2	3 15/16	2 1/2	5 3/8	1 7/8	3
3		1.00		4 3/8	2 5/8	6 1/8	2	3 3/4
4	900	1.70	5/8	5 13/16	3 9/16	8 1/16	2 7/8	4 13/16
5		2.50		6 3/8	3 5/8	9 3/16	2 15/16	5 15/16
6	1,300	3.80	3/4	7 5/8	4 5/16	10 15/16	3 1/2	7 1/16
8	1,800	6.10	7/8	9 5/8	4 7/8	13 1/2	3 7/8	9 1/16

Fig. 69

Adjustable Swivel Ring, Tapped Per NFPA Standards

Size Range: 1/2" through 8"

Material: Carbon steel

Finish: Galvanized

Service: Recommended for suspension of non-insulated **stationary** pipe line.

Maximum Temperature: 650° F

Approvals: Complies with Federal Specification A-A-1192A (Type 10)

WW-H-171-E (Type 10), ANSI/MSS SP-69 and MSS SP-58 (Type 10).

UL Listed and FM Approved (Sizes 3/4" - 8").

Features:

- Threads are countersunk so that they cannot become burred or damaged.
- Knurled swivel nut provides vertical adjustment after piping is in place.
- Captured swivel nut in the 1/2" through 6" sizes. The capture is permanent in the bottom portion of the band, allowing the hanger to be opened during installation if desired, but not allowing the nut to fall completely out.

Ordering: Specify size, figure number and name.

Note: The acceptability of galvanized coatings at temperatures above 450°F is at the discretion of the end user.

Metric nut available upon request. Non-captured nut also available upon request.

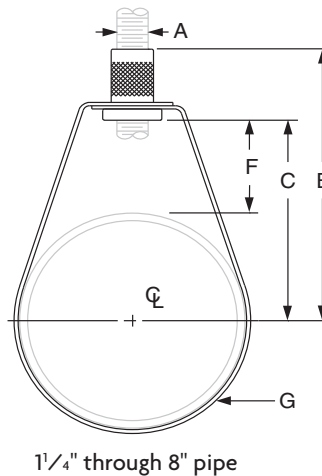
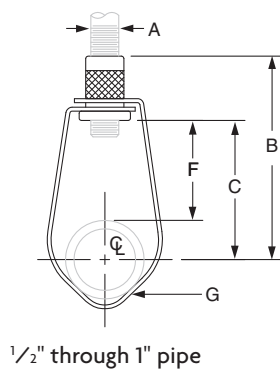

FIG. 69: LOADS (LBS) • WEIGHT (LBS) • DIMENSIONS (IN)

Pipe Size	Max Load	Weight	Rod Size A	B	C	F	G Width
1/2	300	0.10	3/8	2 7/8	2	1 9/16	5/8
3/4		0.10		2 3/4	1 7/8	1 5/16	
1		0.10		2 9/16	1 11/16	1	
1 1/4		0.10		2 5/8	1 3/4	7/8	
1 1/2		0.10		2 3/4	1 7/8	1 1/8	
2	525	0.11	1/2	3 1/4	2 3/8	1 1/8	3/4
2 1/2		0.20		4	2 3/4	1 5/16	
3		0.20		3 13/16	2 15/16	1 3/16	
4	650	0.30	1/2	4 11/16	3 13/16	1 9/16	1
5		0.54		5 5/16	4 3/8	2 1/4	
6	1,000	0.65	1/2	6 11/16	5 9/16	2 1/4	1
8		1.00		8	7	2 11/16	

Note: Reflects changes in rod diameter from previously published data per recent revisions in MSS-SP-58 & 69



- Pictorial Table of Contents
- General Notes
- Copper Tubing Hangers
- CPVC Pipe Hangers
- Pipe Rings**
- Clevis Hangers
- Steel Pipe Clamps
- Socket Clamps
- Beam Clamps
- Structural Attachments
- Brackets
- Ceiling Plates & Flanges
- Concrete Inserts & Attachments
- Hanger Rods
- Rod Attachments
- Bolts, Nuts, Pins & U-Bolts

CLEVIS HANGERS

Fig. 67

Pipe or Conduit Hanger

Size Range: 1/2" through 6"

Material: Carbon steel

Finish: Galvanized

Service: Can be suspended by hanger rod or attached to wall. "T" slot in hanger permits side bolt to be installed after installation and setting of pipe.

Approvals: Complies with Federal Specification A-A-1192A (Type 5), ANSI/MSS SP-69 and MSS SP-58 (Type 5).

Components: Strap and bolt with nut – assembled.

Ordering: Specify pipe size, figure number and name.

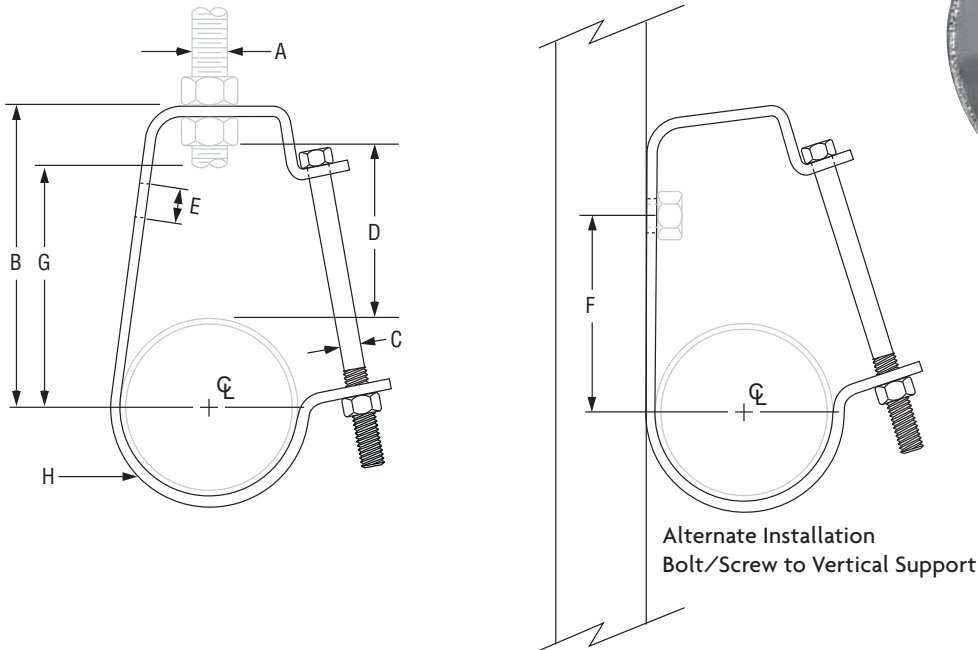

FIG. 67: LOADS (LBS) • WEIGHT (LBS) • DIMENSIONS (IN)

Pipe Size	Load Rating	Weight	Rod Size A	B	C	D	E	F	G	H Width
1/2	400	0.21	3/8	2 ⁵ / ₈	1/4	1 ³ / ₄	7/16	1 ¹ / ₂	1 ¹⁵ / ₁₆	1
3/4		0.22		2 ⁷ / ₈		1 ⁷ / ₈		1 ¹¹ / ₁₆	2 ¹ / ₈	
1		0.25		2 ¹⁵ / ₁₆		1 ¹⁵ / ₁₆		1 ¹³ / ₁₆	2 ⁵ / ₁₆	
1 ¹ / ₄		0.27		3 ¹ / ₄		2		2 ¹ / ₁₆	2 ⁵ / ₈	
1 ¹ / ₂		0.29		3 ⁹ / ₁₆		2 ³ / ₁₆		2 ⁷ / ₁₆	2 ⁷ / ₈	
2	500	0.31	1/2	3 ¹¹ / ₁₆	3/8	2 ¹ / ₈	9/16	2 ⁹ / ₁₆	3 ¹ / ₁₆	1 ¹ / ₄
2 ¹ / ₂		0.71		4 ⁷ / ₁₆		2 ⁷ / ₁₆		3 ³ / ₁₆	3 ⁵ / ₈	
3	550	0.78	5/8	4 ¹³ / ₁₆	3/4	2 ⁹ / ₁₆	9/16	3 ¹ / ₂	4 ¹ / ₁₆	1 ¹ / ₄
4		1.39		6 ¹ / ₈		3 ³ / ₁₆		4 ⁵ / ₈	5 ³ / ₁₆	
5		1.66		6 ³ / ₄		3 ¹ / ₄		5 ¹ / ₁₆	5 ³ / ₄	
6	600	2.26	3/4	7 ³ / ₄		3 ³ / ₁₆		5 ¹³ / ₁₆	6 ⁵ / ₈	

Fig. 65

Light Duty Adjustable Clevis

Size Range: 3/8" through 4"

Material: Carbon steel

Finish: Plain or Galvanized

Service: Recommended for suspension of **stationary** pipe or conduit.

Maximum Temperature: Plain 650° F, Galvanized and Epoxy 450° F

Approvals: Complies with Federal Specification WW-H-171-E (Type 12).

Installation: Hanger load nut above the clevis must be tightened securely to assure proper hanger performance.

Adjustment: Vertical adjustment is provided, varying with the size of clevis. Tighten upper nut after adjustment.

Features: An economical attachment for light duty service.

Ordering: Specify pipe size, figure number, name and finish.

Metric nut available upon request.

Caution: When an oversize clevis is used, a pipe spacer or multispacer should be placed over clevis bolt to ensure that the lower U-strap will not move in on the bolt.

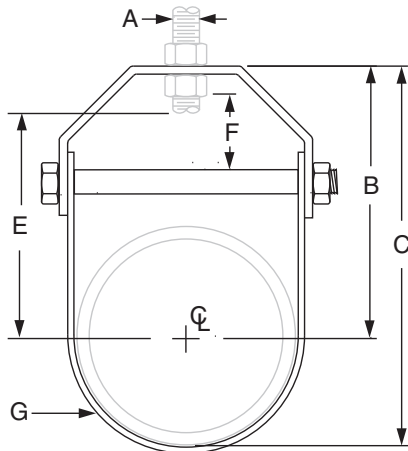

FIG. 65: LOADS (LBS) • WEIGHT (LBS) • DIMENSIONS (IN)

Pipe Size	Max Load	Weight	Rod Size A	B	C	Rod Take Out E	Adjustment F	G Width Lower
3/8	150	0.09	3/8	1 1/2	1 27/32	1 1/16	5/16	5/8
1/2		0.10		1 11/16	2 3/32	1 1/4	7/16	
3/4	250	0.17		1 7/8	2 13/32	1 7/16	1/2	3/4
1		0.18		2 5/32	2 13/16	1 11/16	5/8	
1 1/4		0.21		2 17/32	3 3/8	2 1/16	13/16	
1 1/2		0.24		2 13/16	3 13/16	2 3/8	15/16	
2		0.26		3 11/32	4 17/32	2 7/8	1 3/16	
2 1/2	350	0.50		3 27/32	5 9/32	3 1/4	1 5/16	
3		0.59		4 15/32	6 7/32	3 7/8	1 5/8	
3 1/2		0.62		4 31/32	6 31/32	4 3/8	1 7/8	
4	400	0.77	5 17/32	7 25/32	4 15/16	2 1/8		

CLEVIS HANGERS

Fig. 260

Adjustable Clevis Hanger

Size Range: 1/2" through 30"

Material: Carbon steel

Finish: Plain, Galvanized, or Primed, also available in Plastic or Epoxy Coated

Service: Recommended for the suspension of stationary pipe lines.

Maximum Temperature: Plain 650° F, Galvanized and Epoxy 450° F

Approvals: Complies with Federal Specification A-A-1192A (Type 1), WW-H-171-E (Type 1), ANSI/MSS SP-69 and MSS SP-58 (Type 1). UL (Sizes 3/4" through 8"), ULC Listed (Sizes 3/4" through 4") and FM Approved (Sizes 3/4" through 8").

Installation: Hanger load nut *above* clevis must be tightened securely to assure proper hanger performance.

Adjustment: Vertical adjustment without removing pipe may be made from 3/8" through 5 1/8", varying with the size of clevis. Tighten upper nut after adjustment.

Features:

- Design has yoke on outside of lower U-strap so yoke cannot slide toward center of bolt, thus bending of bolt is minimized.
- Sizes 5" and up have rod and two nuts instead of bolt and nut; thread length on clevis rod is such that the thread locks the nuts in place, and threads are not in shear plane.

Ordering: Specify pipe size, figure number, name and finish.

Notes: Punched forming holes may be present on certain sizes of this clevis hanger. These holes are solely for the purpose of manufacturing, and do not effect the structural integrity or load carrying capacities of these hangers. For insulated line options without shields, see Figures 260 ISS and Figure 300. For insulated line options with shields, see Figures 167 and 168. For ductile iron pipe sizes, see Figure 590.

Caution: When an oversize clevis is used, a pipe spacer or multispace should be placed over clevis bolt to ensure that the lower U-strap will not move in on the bolt.

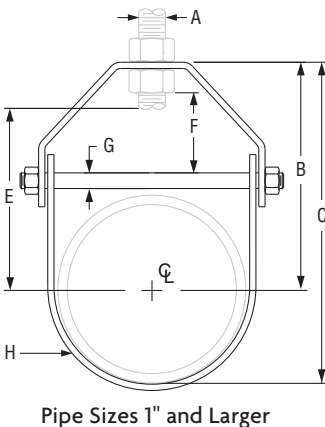
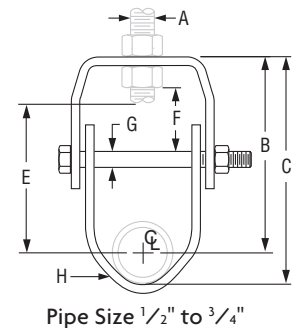
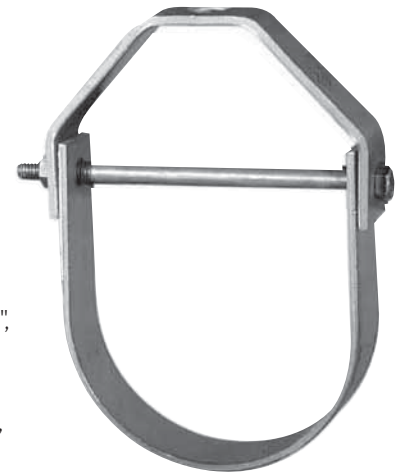

FIG. 260: LOADS (LBS) • WEIGHTS (LBS) • DIMENSIONS (IN)

Pipe Size	Max Load	Span Ft.	Weight	Rod Size A	B	C	Rod Take Out E	Adjust. F	G	H Width Lower	
1/2	610	7*	0.34	3/8	2 3/16	2 11/16	1 1/2	5/8	1/4	1	
3/4			0.34		2		1 5/16				
1	730	9*	0.35	3/8	2 5/16	3 1/4	1 5/8	7/8	3/8		
1 1/4			0.40		2 3/8		1 11/16				
1 1/2			0.45		2 13/16		2 1/8				
2	1,350	11*	0.50	1/2	3 5/16	4 1/2	2 5/8	1 1/8	3/8		
2 1/2			0.65		4 1/16		5 1/2			3 3/16	1 5/16
3			0.85		4 3/4		6 1/2			4 1/16	1 5/8
3 1/2	1,430	13*	1.10	5/8	5 1/16	7 1/16	4 3/16	1 13/16	3/8	1 1/4	
4			1.51		5 9/16		7 13/16				4 1/2
5	1,940	16*	1.70	3/4	6 9/16	8 5/16	5 1/2	1 15/16	3/8	1 3/16	
6			3.10		6 15/16		10 1/4				5 3/4
8	2,000	19*	4.75	7/8	8 3/8	12 11/16	7 3/16	2	1/2	1 7/16	
10	3,600	22*	8.60		9 7/8		15 1/4				8 7/16
12	3,800	23*	11.20	1	11 9/16	17 15/16	10 1/8	2 3/16	5/8	2	
14	4,200	25*	12.50		12 9/16		19 9/16				10 11/16
16	4,600	27	19.85	1	14	22	12	2 3/4	1	2 1/2	
18	4,800	28	22.25		15 15/16		24 15/16				13 15/16
20	4,800	30	40.33	1 1/4	17 7/16	27 9/16	15 1/16	3 7/8	1 1/4	3	
24	4,800	32	49.83		19 13/16		31 13/16				17 7/16
30	6,000	33	70.18		24 3/16		39 3/16				21 1/16

"Span" represents the maximum recommended distance between hangers on a continuous and straight run of horizontal standard weight steel pipe filled with water. In all cases, verify that chosen location of hangers does not subject hangers to a load greater than the maximum recommended load shown above. *Indicates that span represents the maximum span for water filled pipe as given in Table 1 of page 225.

Fig. 260 ISS

Clevis Hanger with Insulation Saddle System

Size Range: 1/2" through 12" pipe and accommodates up to 2" of insulation.

Material: Carbon steel with high impact glass reinforced polypropylene saddle and carbon steel pipe spacer.

Finish: Plain or Galvanized Clevis Hanger

Service: Recommended for the suspension of stationary insulated chilled or hot water pipe lines.

Maximum Temperature: 40° F to 200° F

Approvals: Dual Fire Ratings, UL E94 VO and ASTM E84 Class 1 25/60.

Installation: Hanger load nut above clevis must be tightened securely to assure proper performance. Position the pipe on the saddle. Notch insulation to fit around the saddle. Square cut adjoining insulation and butt the insulation ends to each other. Insulation joint is coated, caulked and taped following standard insulation practice used on flanges and valves.

Adjustment: Vertical adjustment without removing the hanger may be made 7/8" through 2 3/8" varying with the size of the clevis. Tighten all nuts after adjustment.

Features: V-Block design cradles pipe through out the entire erection process. Clevis bolt spacer included as standard keeps the clevis lower strap from collapsing.

Eliminates:

- Wood blocks and standard shields
- Costly calcium silicate inserts
- Re-leveling of piping at each individual hanger after insulation is completed.

Ordering: Specify size number, pipe size, insulation thickness, figure number name and finish.



FIG. 260 ISS SIZING TABLE						
Pipe Size	Insulation Thickness					
	1/2"	3/4"	1"	1 1/2"	2"	
(Size Number)						
1/2	2	2	3	—	—	
3/4	2	3	3	—	—	
1	2	3	3	—	—	
1 1/2	3	4	4	—	—	
2	4	4	5	—	—	
2 1/2	5	5	5	6	8	
3	5	5	5	6	8	
3 1/2	5	6	6	8	8	
4	6	6	8	8	8	
5	8	8	8	10	10	
6	10	10	10	10	10	
8	12	12	12	12	12	
10	14	14	14	14	16	
12	16	16	16	16	—	

FIG. 260 ISS SIZING TABLE					
Copper Tube Size	Insulation Thickness				
	1/2"	3/4"	1"	1 1/2"	2"
(Size Number)					
3/8	2	2	3	—	—
1/2	2	2	3	—	—
5/8	2	2	3	—	—
3/4	2	2	3	—	—
1	2	3	3	—	—
1 1/4	3	3	3	—	—
1 1/2	3	3	4	—	—
2	4	4	4	—	—
2 1/2	4	5	5	6	—
3	5	5	5	6	8
3 1/2	5	5	6	8	8
4	6	6	8	8	8
5	8	8	8	8	10
6	8	10	10	10	10
8	10	10	12	12	12

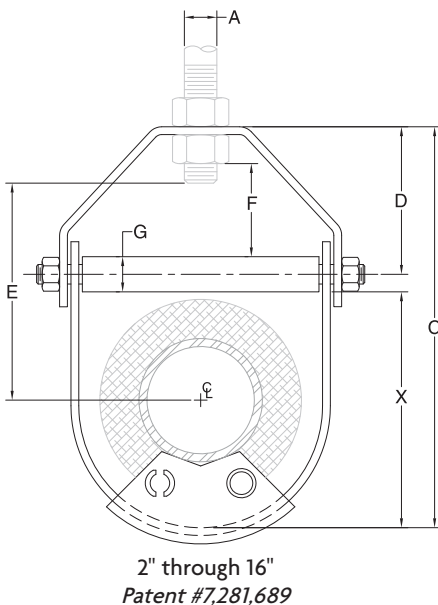

FIG. 260 ISS: LOADS (LBS) • WEIGHTS (LBS) • DIMENSIONS (IN)								
260 ISS Size Number	*Max Load	Weight	Rod Size A	C	**Rod Take Out E	Adjust. F	G	X
2	550	0.73	3/8	4 1/2	2 5/8	7/8	1/4	2 3/8
3		1.32	1/2	6 1/2	4 1/16	1 7/16	3/8	3 5/8
4		1.83	5/8	7 13/16	4 1/2	1 1/2		4 1/2
5	2.44	8 15/16		5 1/2	1 3/4	5 11/16		
6	750	3.81	3/4	10 1/4	5 3/4	1 1/2	1/2	6 11/16
8	1100	5.60		12 11/16	7 3/16	1 3/4		8 13/16
10		9.73	7/8	15 1/4	8 7/16	1 7/8	5/8	10 3/4
12		13.80		17 15/16	10 1/8	2 9/16		12 7/16
14	1700	15.60	1	19 9/16	10 11/16	2 1/2	3/4	14 7/16
16		26.81		22	12	2 3/8	1	16 5/16

* Max load exceeds dead weight load requirement of pipe at max span, except 14 and 16 where max load is based on industry standard spacing of 14. Further information on typical pipe spans and piping weight per length can be found on pages 225 and 227, respectively.

** Based on maximum insulation thickness, variations due to pipe size and insulation thickness may occur.

Fig. 260 ISS Clevis Hanger with Insulation Saddle System (cont.)

Application: Anvil's insulation saddle system clevises are fully tested and rated for a temperature range from 40°F to 200°F. Ideal for the suspension of stationary insulated chilled or hot water pipelines.

Chilled Water Testing: Extensive field-testing and inspection has been performed to confirm that the integrity of the insulation vapor barrier for chilled water systems are sustained with the 260 ISS.

To Assure Proper Vapor Barrier: Each insulation joint should be properly coated, caulked and taped. Applying standard insulation practice that is used on flanges and valves.

Features: The Anvil 260 (ISS) Insulation Saddle System reduces your overall installation time and greatly simplifies the way you insulate copper and steel pipe systems. Contractors can support insulated pipe with less parts and labor.

The revolutionary design of the 260 ISS spreads the load evenly over the lower strap of the clevis. The innovative V-Block design cradles the pipe at the design elevation throughout the erection process. The wide base V-Block design accommodates multiple pipe sizes, reducing the on-site inventory and the flexibility of pipe and insulation combinations with each size number.

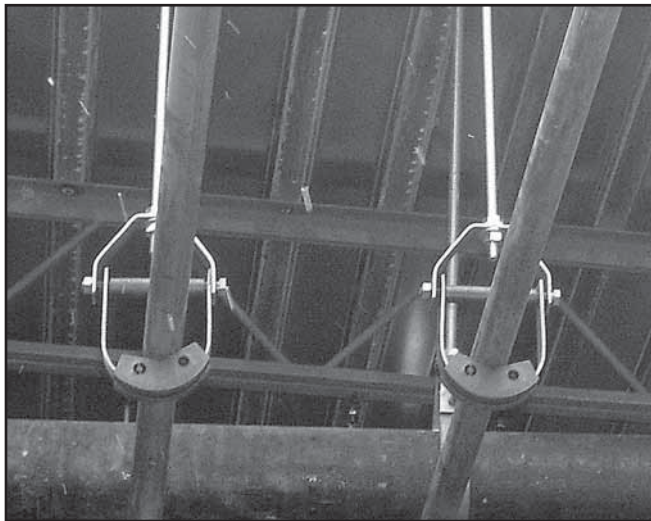
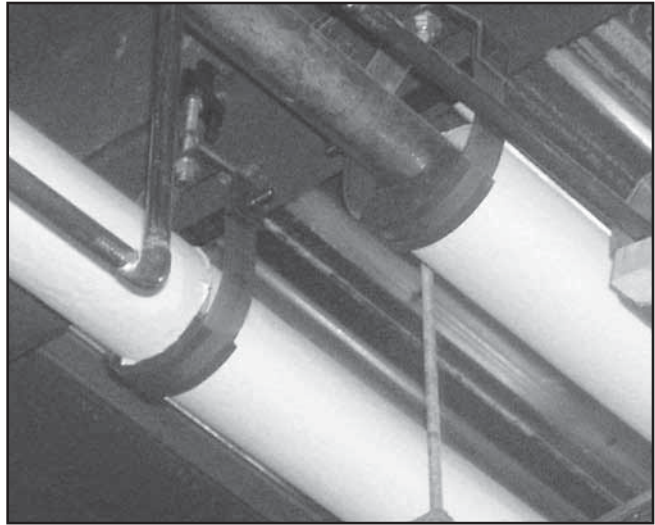

ASTM & UL Fire Ratings: The 260 ISS has been independently tested by ASTM and UL for:

- Flame Spread Index (FSI)
- Smoke Development (SD) and drip ratings

Approvals from both agencies with the highest ratings for the type of product.

Low Thermal Conductivity: V-Block low thermal conductivity of .77 BTU-In./Sq.FT-Hr°F

Insulation R-Values: The Figure 260 ISS polymer V-Block component has an R-value ranging from 5.0 to 8.7, depending on the hanger size. Meets or exceeds most commercial insulation R-values.

Fig. 260 ISS Clevis Hanger with Insulation Saddle System (cont.)

Easy Installation

Make sure the double hex nuts installed with the upper hanger load nut above the clevis are tightened securely. Position pipe on saddle.

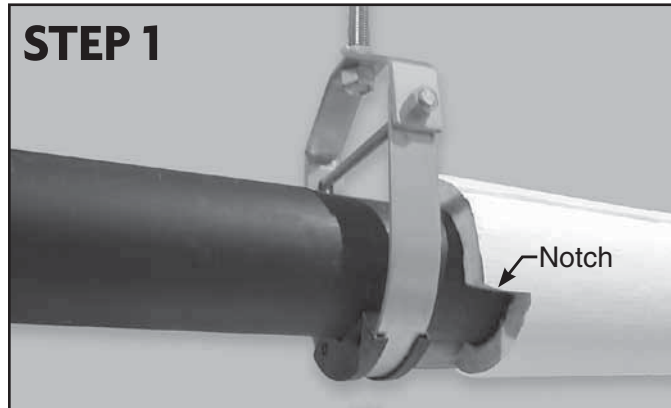

Cope or notch insulation to fit around saddle. The notch should be deep enough to extend $\frac{1}{8}$ " to $\frac{1}{4}$ " beyond the saddle.

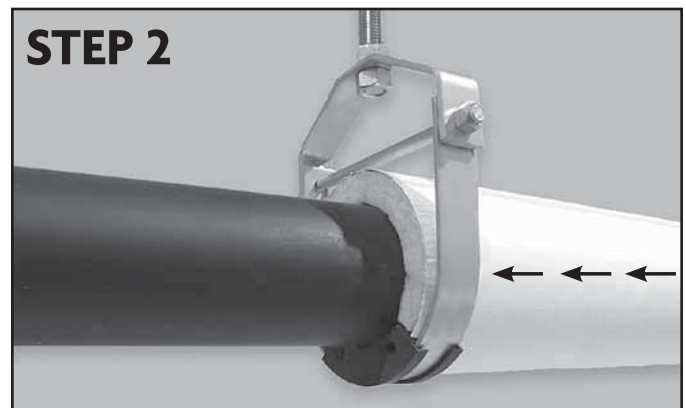

Slide the notched insulation section over saddle.

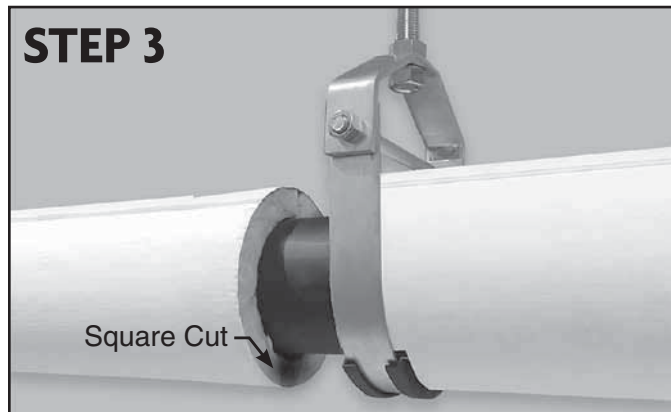

Square cut adjoining insulation and butt the insulation ends to each other.

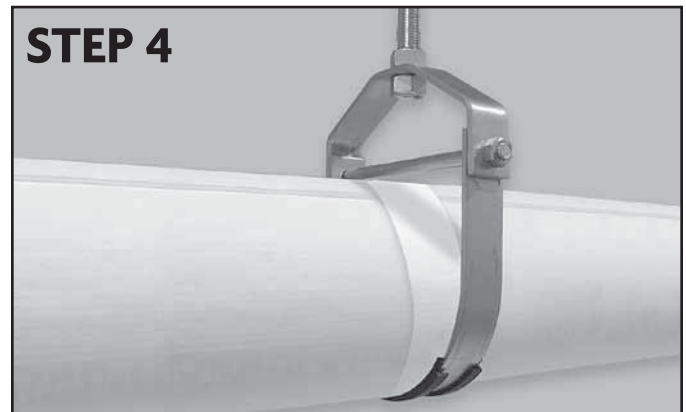

Caulk joints and finish taping.

To assure proper vapor barrier: Each insulation joint should be properly coated, caulked and taped. Applying standard insulation practice that is used on flanges and valves.

Finish via standard taping method.

For chilled systems a mastic for thermal insulations or similar sealant is typically used:

Systems (50°F or greater) apply sealant to:

- The coped and flat edges of the mating insulation sections.
- The V-Block saddle at the insulation interface.

Systems (Below 50°F) apply sealant as per 50 Degrees with additional sealant to:

- The V-Block saddle joint between the two saddle halves.



Mastic applied to V-Block saddle at insulation interface. (50°F or greater)

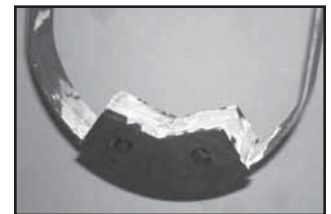

Additional sealant applied to V-Block saddle joint between the two saddle halves. (Chilled water below 50°F)

CLEVIS HANGERS

Fig. 300

Adjustable Clevis for Insulated Lines

Size Range: 3/4" through 12"

Material: Carbon steel

Finish: Plain, Galvanized or Epoxy coated

Service: Recommended for suspension of insulated **stationary** pipe lines.

Maximum Temperature: Plain 650° F, Galvanized and Epoxy 450° F

Approvals: Complies with Federal Specification A-A-1192A (Type 1) WW-H-171-E (Type 1), ANSI/MSS SP-69 and MSS SP-58 (Type 1).

Installation: Hanger load nut above clevis must be tightened securely to assure proper hanger performance.

Adjustment: Vertical adjustment is provided, varying with the size of the clevis. Tighten upper nut after adjustment.

Features:

- Designed for 2" of insulation on 3/4" through 1 1/2" pipe and 4" of insulation on 2" and larger pipe.
- When properly installed, clevis bolt is outside the insulation.

Ordering: Specify pipe size, figure number, name and finish.

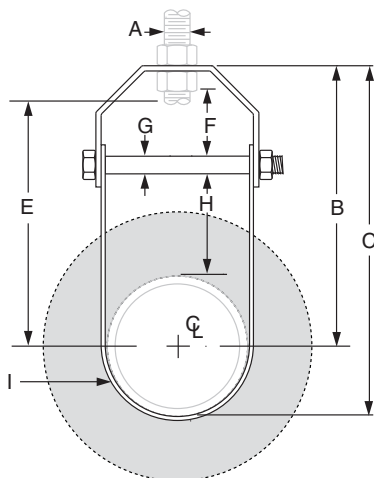

FIG. 300: LOADS (LBS) • WEIGHT (LBS) • DIMENSIONS (IN)

Pipe Size	Max Load	Weight	Rod Size A	B	C	E	Adjustment F	G	H	I Width Lower
3/4	730	0.51	3/8	3 5/8	4 1/4	2 7/8	1/2	1/4	2	1
1		0.58		4	4 11/16	3 1/4	5/8			
1 1/4		0.64		4 7/16	5 1/4	3 5/8	7/8			
1 1/2		0.72		4 3/4	5 3/4	4 1/16	1 1/16			
2		0.85		7 7/16	8 11/16	6 1/2	1 5/8			
2 1/2	1,350	1.90	1/2	8 7/16	9 15/16	7 1/2	2	3/8	4	1 1/4
3		2.00		8 5/8	10 5/16	7 9/16	1 3/4			
4	1,430	2.50	5/8	9 3/8	11 5/8	8 3/16	1 15/16	1/2	4	1 1/2
5		3.00		9 7/8	12 5/8	8 3/4	1 3/4			
6		3.40		10 5/8	14	9 3/8	1 7/8			
8	2,000	6.70	3/4	12 3/8	16 3/4	11	2	5/8	4	1 3/4
10	3,600	11.0		13 3/4	19 9/16	12 1/4	2 1/8			
12	3,800	13.8		15 1/8	21 9/16	13 5/8	2 7/16			

Fig. 590

Adjustable Clevis for Ductile or Cast Iron Pipe

Size Range: 4" through 24" ductile or cast iron pipe

Material: Carbon steel

Finish: Plain or Galvanized

Service: Recommended for the suspension of **stationary** ductile iron or cast iron pipe.

Approvals: Complies with Federal Specification A-A-1192A (Type 1)

WW-H-171-E (Type 1), ANSI/MSS SP-69 and MSS SP-58 (Type 1).

Installation: Hanger rod nut above clevis must be tightened securely to assure proper hanger performance.

Adjustment: Vertical adjustment without removing pipe may be made from 1⁵/₁₆" through 3³/₁₆", varying with the size of the clevis. Tighten upper nut after adjustment.

Ordering: Specify pipe size, figure number, name and finish.

Note: Figure 590 sizes 12" and below typically feature a Figure 260 Top Component.

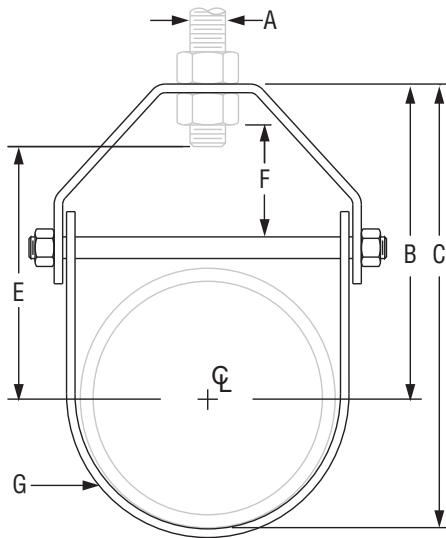

FIG. 590: LOADS (LBS) • WEIGHT (LBS) • DIMENSIONS (IN)

D.I./C.I. Pipe Size	Max Load	Weight	D.I./C.I. Pipe O.D.	Rod Size A	B	C	E	F	G Width Lower
3	1,350	1.10	3.96	1/2	5 ⁵ / ₁₆	7 ¹ / ₁₆	4 ³ / ₁₆	1 ¹³ / ₁₆	1 ¹ / ₄
4	1,430	1.64	4.80	5/8	5 ³ / ₄	8 ³ / ₁₆	4 ³ / ₄	1 ¹⁵ / ₁₆	
6	1,940	4.26	6.90	3/4	7 ⁷ / ₈	10 ⁹ / ₁₆	5 ¹⁵ / ₁₆		2 ¹ / ₄
8	2,000	6.70	9.05		7/8	8 ⁵ / ₈	13 ³ / ₁₆	7 ¹ / ₂	
10	3,600	9.73	11.10	1	10 ⁵ / ₈	15 ¹¹ / ₁₆	8 ³ / ₄	2 ⁵ / ₁₆	2
12	3,800	13.64	13.20		12 ¹ / ₁₆	18 ¹¹ / ₁₆	10 ¹¹ / ₁₆	2 ⁷ / ₈	
14	4,200	16.04	15.30		13 ¹ / ₄	20 ⁷ / ₈	11 ⁵ / ₁₆	2 ⁹ / ₁₆	2 ¹ / ₂
16	4,600	24.52	17.40	1 ¹ / ₄	14 ¹ / ₄	22 ¹⁵ / ₁₆	12 ⁹ / ₁₆	3 ¹³ / ₁₆	
18	4,800	27.45	19.50		16 ⁷ / ₈	26 ⁵ / ₈	15 ³ / ₁₆		3
20	4,800	46.24	21.60	1 ¹ / ₄	18 ¹ / ₄	29 ¹ / ₁₆	16 ³ / ₈	3	
24	4,800	57.10	25.80		20 ⁵ / ₁₆	33 ¹ / ₄	18 ³ / ₈		

Fig. 261

Extension Pipe or Riser Clamp

Size Range: 3/4" through 24"

Material: Carbon steel

Finish: Plain, Galvanized or Epoxy coated

Service: For support of stationary steel pipe risers, cast iron pipe or conduit. This product is not intended for use with hanger rods. For this application refer to Fig. 40 Riser Clamp, page 43.

Maximum Temperature: Plain 650° F, Galvanized and Epoxy 450° F

Approvals: Complies with Federal Specification A-A-1192A (Type 8) WW-H-171-E (Type 8), ANSI/MSS SP-69 and MSS SP-58 (Type 8). UL, ULC Listed (Sizes 1 1/2" - 8").

Installation: Clamp is fitted and bolted preferably below a coupling, hub or welded lugs on steel pipe. Bolt torques should be per industry standards (see page 233). Clamp is designed for standard steel pipe O.D. and this must be considered in sizing the riser for other types of piping.

Ordering: Specify pipe size, figure number, name and finish.



Note: Refer to Technical Data Section for cast iron soil pipe data.

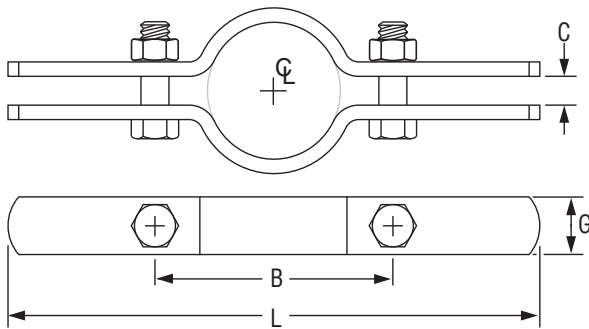

FIG. 261: LOADS (LBS) • WEIGHT (LBS) • DIMENSIONS (IN) • TORQUE (FT-LBS)

Pipe Size	Max Load	Weight	L	G Width	B	C	Bolt Diameter	Torque Values
3/4	220	1.1	8 7/8	1	2 7/8	3/8	3/8	21
1		1.1			3 1/8			
1 1/4	1.6	3 1/2						
1 1/2	250	1.6	10 1/4		3 7/8	1/2	7/16	
2		1.7			4 1/4			
2 1/2	400	1.9	11 1/4		4 3/4			
3	500	1.9	11 3/8	5 1/2				
3 1/2	600	2.3	12 7/8	6 1/2				
4	750	2.4		7	1/2	1/2	46	
5	1,500	3.6	13 3/4	8				
6	1,600	4.0	14 3/4	1 1/2	9	5/8	5/8	100
8	2,500	7.6	18 1/2		12			
10		11.1	20 1/4	2	13 3/4			
12	2,700	16.5	22 3/4		15 3/4	3/4	3/4	150
14		17.7	24	17 1/4				
16	2,900	30.4	26	2 1/2	19 3/4	1	7/8	190
18		33.8	28		21 3/4			
20		35.0	30		23 3/4			
24	3,200	82.0	36 3/4	3	30			

Fig. 40

Riser Clamp – Standard

Size Range: 2" through 24"

Material: Carbon steel (CS), Alloy (A), or Stainless Steel (SS)

Finish: Plain or Galvanized

Maximum Temperature: Galvanized 450° F, 650° F (CS), 950° F (A) and 1,000° F (SS)

Service: Riser clamps are used for the support of vertical piping. Load is carried by shear lugs which are welded to the pipe. Shear lugs provided upon request. Local pipe wall stress evaluation available upon request.

Approvals: Complies with Federal Specification A-A-1192A (Type 42), ANSI/MSS SP-69 and MSS SP-58 (Type 42).

Ordering: Specify pipe size, material, figure number, name and finish.

Note: If different loads or dimensions are required, refer to Fig. 40 SD special design riser clamp.

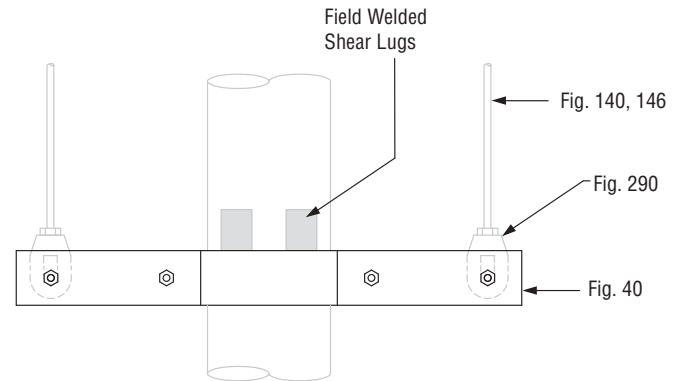
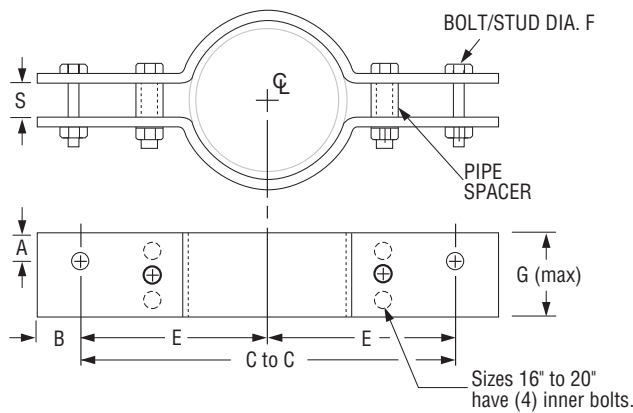

For Shear Lug Dimensions, refer to Special Design Products Fig. 40SD.

FIG. 40: LOADS (LBS) • WEIGHT (LBS) • DIMENSIONS (IN)

Pipe Size	Max Load		C-C	E	F (max)	G (max)	S	A (CS)	A (alloy) (SS)	B (max)	Maximum Weight Each			
	Rigid Assembly	Spring Assembly									CS	SS	Alloy	
2	900	1,800	18	9	1/2	2 1/2	3/4	1 1/4	7/8	2	18	15	18	
2 1/2			20	10							20	20	20	
3	1,500	3,000	22	11	5/8	3	1 1/2	1 1/8	30		25	30		
4	2,200	4,400							40		40	44		
5			3,000	6,000	24	12	7/8	4	1 1/4		45	40	45	
6	27	13 1/2			5	1 1/2					7/8	1 1/4	60	60
8	5,500	11,000	30	15	1 1/4	6	2 1/4	1 1/4	1 1/8		3	82	82	82
10			32	16								7	2 1/2	1 1/8
12	7,800	15,600	34	17	1 1/2	6	1 1/2	2	216	202				
14			36	18					7	1 1/8		1 1/8	228	228
16	9,000	18,000	39	19 1/2	2	8	3 1/2	2 5/8	2 5/8	4 1/4		314	277	315
18			42	21								7	2	338
20	13,500	27,000	45	22 1/2	2	8	3 1/2	2 5/8	2 5/8			525	525	580
24			45	22 1/2								8	3 1/2	2 5/8

- Pictorial Table of Contents
- General Notes
- Copper Tubing Hangers
- CPVC Pipe Hangers
- Pipe Rings
- Clevis Hangers
- Steel Pipe Clamps
- Socket Clamps
- Beam Clamps
- Structural Attachments
- Brackets
- Ceiling Plates & Flanges
- Concrete Inserts & Attachments
- Hanger Rods
- Rod Attachments
- Bolts, Nuts, Pins & U-Bolts

STEEL PIPE CLAMPS

Fig. 103

Offset Pipe Clamp

Size Range: 3/4" through 8"
Material: Carbon steel
Finish: Plain or Galvanized
Service: For use in supporting piping away from wall or floor.
Maximum Temperature: Plain 650° F, Galvanized 450° F
Ordering: Specify pipe size, figure number, name and finish
Service: For use in supporting horizontal piping away from the wall or floor (not to be used as a riser type support)

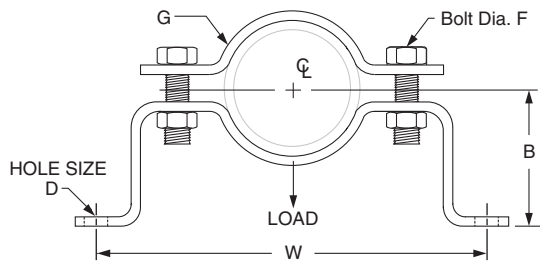

FIG. 103: LOADS (LBS) • WEIGHT (LBS) • DIMENSIONS (IN)

Pipe Size	Max Load	Weight	W	B	D	Bolt Dia. F	G Width
3/4	190	1.50	8 3/4	2 1/2	7/16	3/8	1 1/4
1		1.60	9 1/4	2 5/8			
1 1/4		1.70	9 3/4	2 13/16			
1 1/2		1.80	10	2 15/16			
2	420	2.70	11 1/4	3 3/16	9/16	1/2	1 1/2
2 1/2		2.90	11 3/4	3 1/16			
3		3.20	12 7/8	3 3/4			
4	610	4.60	13 7/8	4 1/4	1 1/16	5/8	2
5		7.30	15 5/8	4 3/4			
6	870	7.80	16 3/4	5 5/16			
8		9.00	18 3/4	6 5/16			

Fig. 100

Extended Pipe Clamp

Size Range: 1/2" through 8"
Material: Carbon steel
Finish: Plain or Galvanized
Service: For attachment to structure without use of rods.
Maximum Temperature: Plain 650° F, Galvanized 450° F
Ordering: Specify pipe size, figure number, name and finish.

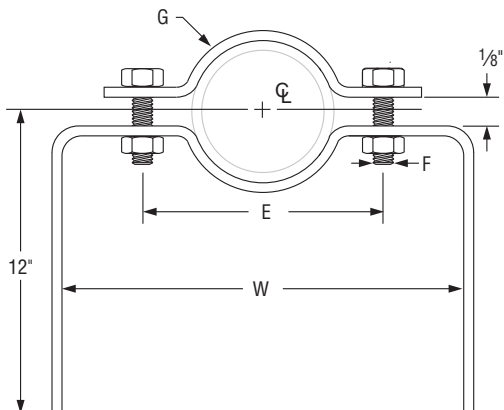
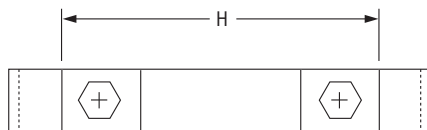

FIG. 100: WEIGHT (LBS) • DIMENSIONS (IN)

Pipe Size	W	E	F	G Width	H	Weight
1/2	5 5/8	2 7/8	3/8	1	4 1/4	1.85
3/4	5 7/8	3 1/8			4 1/2	2.20
1	6 3/8	3 5/8			5	2.25
1 1/4	6 7/8	4 1/8			5 1/2	2.34
1 1/2	7 1/8	4 3/8	1/2	1 1/4	5 3/4	2.39
2	8 3/8	5 1/8			6 7/8	3.25
2 1/2	8 7/8	5 5/8			7 7/8	3.40
3	10	6 3/4			8 1/4	3.58
4	10 5/8	7 3/8	5/8	1 1/2	9 1/8	4.74
5	12 3/8	8 5/8			10 7/8	5.09
6	13 1/2	9 3/4			12	8.23
8	15 1/2	11 3/4			14	9.25

Fig. 212

Medium Pipe Clamp

Size Range: 1/2" through 30"

Material: Carbon steel

Finish: Plain or Galvanized

Service: Recommended for suspension of cold pipe lines or hot lines where no insulation is required.

Maximum Temperature: Plain 750° F, Galvanized 450° F

Approvals: Complies with Federal Specification A-A-1192A (Type 4)

WW-H-171-E (Type 4), ANSI/MSS SP-69 and MSS SP-58 (Type 4).

UL, ULC Listed and FM Approved (Sizes 3/4" - 8").

Installation: Normally used with weldless eye nut Fig. 290, page 97 or eye rod.

Features:

- Clamps tightly to pipe.
- Wide range of sizes.
- Equal gap design on many sizes.

Ordering: Specify pipe size, figure number, name and finish.

Note: The "C" gap dimension ensures adequate clearance at the top attachment point for a weldless eye nut or other appropriate rod attachment. This gap may or may not be present on the bottom portion of the clamp. If different loads or dimensions are required, refer to Fig. 42 SD non-standard two bolt pipe clamp.

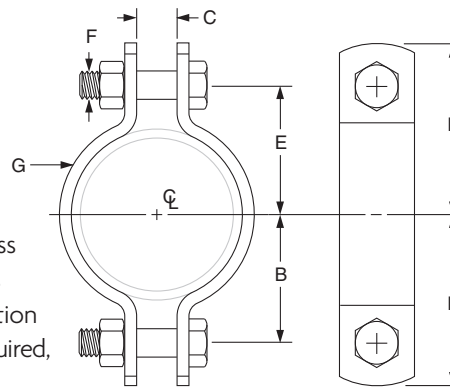

Note: This picture is representative of a typical Figure 212. Distance between clamp ears beneath pipe may or may not be equal to upper gap.

FIG. 212: LOADS (LBS) • WEIGHT (LBS) • DIMENSIONS (IN)

Pipe Size	Span Ft.	Max Load For Service Temp		Weight	B	C	Rod Take Out E	H	D	F	G Width
		650° F	750° F								
1/2	7*	500	-	0.29	1	1/2	1 3/16	1 17/32	1 23/32	5/16	1
3/4				0.33	1 1/8		1 1/4	1 21/32	1 25/32		
1				0.35	1 1/8		1 3/8	1 29/32	1 29/32		
1 1/4				0.38	1 1/16		1 5/8	1 31/32	2 5/32		
1 1/2	9*	800	-	0.43	1 1/16	5/8	1 11/16	2 3/32	2 7/32	1/2	
2				1.10	2 1/8		2 1/8	2 3/4	2 3/4		
2 1/2				1.20	2 5/8		2 5/8	3 1/4	3 1/4		
3				1.40	2 7/8		2 7/8	3 1/2	3 1/2		
3 1/2	12*	1,040	930	1.50	3 3/16	3/4	3 3/16	3 13/16	3 13/16	5/8	
4				1.80	3 1/2		3 1/2	4 1/4	4 1/4		
5				2.60	4 3/16		4 3/16	4 15/16	4 15/16		
6				5.40	4 7/8		4 7/8	5 3/4	5 3/4		
8	17*	1,615	1,440	6.50	6	1 1/4	6	6 7/8	6 7/8	3/4	
10				13.60	7 1/16		7 1/16	8 9/16	8 9/16		
12				15.20	8 7/16		8 7/16	9 9/16	9 9/16		
14				20.50	9 1/4		9 1/4	10 5/8	10 5/8		
16	20	2,490	2,220	22.30	10 1/4	1 1/8	10 1/4	11 5/8	11 5/8	7/8	
18				31.60	11 5/8		11 5/8	13	13		
20				35.80	12 3/4		12 3/4	14 1/8	14 1/8		
24				53.10	15 1/4		15 1/4	16 7/8	16 7/8		
30	9	3,500	3,360	113.90	19	2	19	21 1/8	21 1/8	1 3/4	4

Clamps may be furnished with square ends. "Span" represents the maximum recommended distance between hangers on a continuous & straight run of horizontal standard weight steel pipe filled with water. In all cases, verify that chosen location of hangers does not subject hangers to a load greater than the maximum recommended load shown above. For vapor service, the presence of fittings or insulation, and other weights and types of pipe, spans may either increase or decrease. In all cases, verify that chosen location of hanger does not subject hangers to a load greater than the maximum recommended load shown. *Indicates that span represents the maximum span for water filled pipe as given in Table 1 of page 225.

STEEL PIPE CLAMPS

Fig. 212FP

Earthquake Bracing Clamp

Size Range: 2 1/2" through 12"

Material: Carbon steel

Finish: Plain or Galvanized

Service: For seismic bracing, to be used with Fig. 113 brace fitting.

Pipe clamp bolt holes are designed to match holes in brace fitting.

Maximum Temperature: Plain 750° F, Galvanized 450° F

Approvals: Complies with Federal Specification A-A-1192A (Type 4) WW-H-171-E (Type 4), ANSI/MSS SP-69 and MSS SP-58 (Type 4).

Installation: Designed for use with Fig. 113 brace fitting, see page 71.

Ordering: Specify pipe size, figure number, name and finish.

Note: The "C" gap dimension should be used at the upper and lower locations to ensure proper installation of the clamp.

Standard Figure 212 will be furnished for sizes 2 1/2" thru 4".

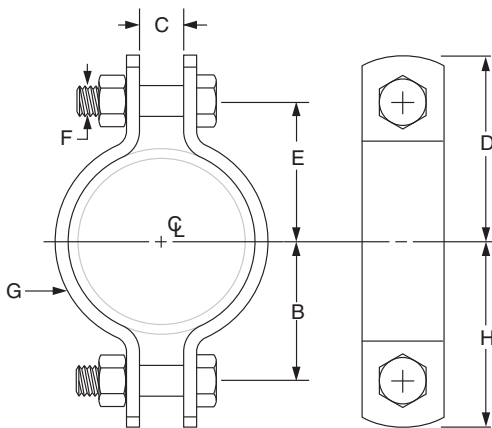

FIG. 212FP: LOADS (LBS) • WEIGHT (LBS) • DIMENSIONS (IN)

Pipe Size	Max Load For Service Temp		Weight (lbs)	B	C	Rod Take Out E	H	D	F	G Width
	650° F	750° F								
2 1/2	1,040	930	1.20	2 5/8	5/8	2 5/8	3 1/4	3 1/4	1/2	1
3			1.40	2 7/8		2 7/8	3 1/2	3 1/2		
3 1/2			1.50	3 3/16		3 3/16	3 3/16	3 3/16		
4			1.80	3 1/2		3 1/2	4 1/4	4 1/4		
5			2.50	4 3/16	3/4	4 3/16	4 15/16	4 15/16		1 1/4
6			5.20	4 7/8	1 1/4	4 7/8	5 3/4	5 3/4		
8			6.30	6		6	6 7/8	6 7/8		
10			13.60	7 7/16	1	7 7/16	8 9/16	8 9/16		2
12			15.20	8 7/16		8 7/16	9 9/16	9 9/16		

Fig. 216

Heavy Pipe Clamp

Size Range: 3" through 42"

Material: Carbon steel

Finish: Plain or Galvanized

Service: Recommended for suspension of pipe lines where no insulation is required.

Maximum Temperature: Plain 750° F, Galvanized 450° F

Approvals: Complies with Federal Specification A-A-1192A (Type 4)

WW-H-171-E (Type 4), ANSI/MSS SP-69 and MSS SP-58 (Type 4).

Installation: Normally used with welded eye rod or with weldless eye nut

Fig. 290, see page 97.

Features:

- Designed for heavy load up to 750° F

Ordering: Specify pipe size, figure number, name and finish.

Note: If different loads or dimensions are required, refer to Fig. 42 SD non-standard two bolt pipe clamp.



Note: This picture is representative of a typical Figure 216. Distance between clamp ears beneath pipe may or may not be equal to upper gap.

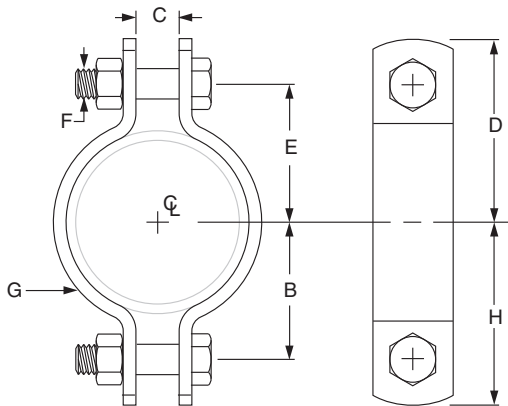

FIG. 216: LOADS (LBS) • WEIGHT (LBS) • DIMENSIONS (IN)

Pipe Size	Max Load For Service Temp		Weight	B	C	D	Rod Take Out E	F	G Width	H
	650° F	750° F								
3	3,370	3,005	3.6	2 ¹⁵ / ₁₆	1	4	3 ¹ / ₈	3 ³ / ₄	2	3 ¹³ / ₁₆
4	3,515	3,135	5.5	3 ⁹ / ₁₆		4 ⁷ / ₈	3 ³ / ₄	7 ⁷ / ₈		4 ¹¹ / ₁₆
5			6.3	4 ¹ / ₈		5 ¹ / ₂	4 ³ / ₈			
6	4,865	4,350	11.7	5	1 ¹ / ₈	6 ⁵ / ₈	5 ¹ / ₄	1	2 ¹ / ₂	6 ³ / ₈
8		4,340	13.9	6 ¹ / ₈		7 ⁵ / ₈	6 ¹ / ₄			7 ¹ / ₂
10	6,010	5,360	22.3	7 ⁹ / ₁₆	1 ¹ / ₄	9 ¹ / ₁₆	7 ¹¹ / ₁₆	1 ¹ / ₄	3	8 ¹⁵ / ₁₆
12	8,675	7,740	38.1	9	1 ⁵ / ₈	10 ⁷ / ₈	9 ¹ / ₄	1 ¹ / ₂		10 ⁵ / ₈
14	9,120	8,135	46.8	9 ³ / ₄		11 ⁷ / ₈	10		11 ⁵ / ₈	
16			51.4	10 ³ / ₄		12 ⁷ / ₈	11			12 ⁵ / ₈
18	13,800	–	130.1	14 ¹ / ₂	3	17 ¹ / ₄	14 ¹ / ₂	2	6	17 ¹ / ₄
20	15,300	–	163.6	16		18 ³ / ₄	16		5	18 ³ / ₄
24	16,300	–	215.2	18 ¹ / ₂	3 ³ / ₄	21 ¹ / ₂	18 ¹ / ₂	2 ¹ / ₄	6	21 ¹ / ₂
28	18,000	–	302.8	20 ¹ / ₂		23 ¹ / ₂	20 ¹ / ₂		8	23 ¹ / ₂
30	20,500	–	365.4	22 ¹ / ₂	3 ¹ / ₂	26	22 ¹ / ₂	2 ¹ / ₂	7	26
32	23,750	–	431.7	23 ¹ / ₂		27	23 ¹ / ₂		7	27
34	25,000	–	533.8	25		28 ¹ / ₂	25		8	28 ¹ / ₂
36	28,000	–	575.1	26 ¹ / ₂		30 ¹ / ₄	26 ¹ / ₂			2 ³ / ₄
42	35,000	–	915.7	30	33 ³ / ₄	30	10	33 ³ / ₄		

- Pictorial Table of Contents
- General Notes
- Copper Tubing Hangers
- CPVC Pipe Hangers
- Pipe Rings
- Clevis Hangers
- Steel Pipe Clamps
- Socket Clamps
- Beam Clamps
- Structural Attachments
- Brackets
- Ceiling Plates & Flanges
- Concrete Inserts & Attachments
- Hanger Rods
- Rod Attachments
- Bolts, Nuts, Pins & U-Bolts

STEEL PIPE CLAMPS

Fig. 295

Double Bolt Pipe Clamp

Size Range: 3/4" through 36"

Material: Carbon steel

Finish: Plain or Galvanized

Service: Recommended for suspension of pipe requiring insulation within the limitation of temperature and loads shown below.

Maximum Temperature: Plain 750° F, Galvanized 450° F

Approvals: Complies with Federal Specification A-A-1192A (Type 3), WW-H-171-E (Type 3), ANSI/MSS SP-69 and MSS SP-58 (Type 3).

Installation: Attachment to the clamp may be made with a welded eye rod Fig. 278, page 93 or the weldless eye nut Fig. 290, see page 97.

Features:

- Sizes 6" and above accommodate up to 4" thick insulation.
- Figure 41SD will accommodate larger insulation thicknesses, loads and dimensions.

Ordering: Specify pipe size, figure number, name and finish.

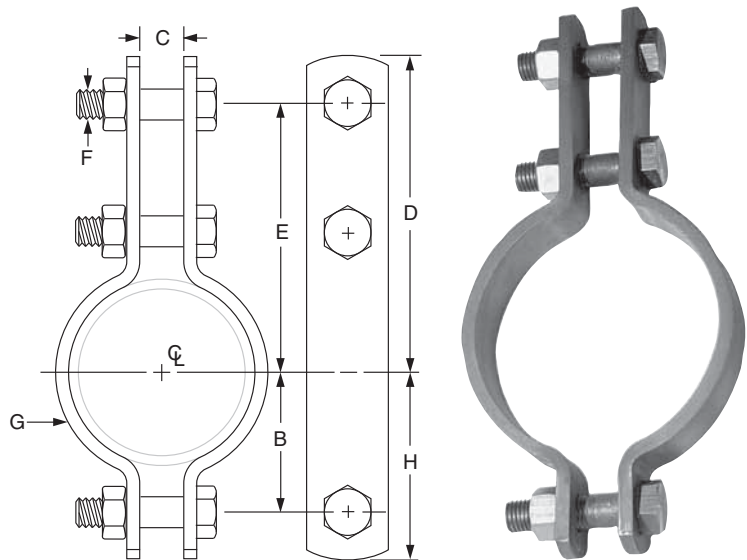

Note: This picture is representative of a typical Figure 295. Distance between clamp ears beneath pipe may or may not be equal to upper gap.

FIG. 295: LOADS (LBS) • WEIGHT (LBS) • DIMENSIONS (IN)

Pipe Size	Max Span Ft.	Max Load For Service Temp.		Weight	B	C	D	Rod Take Out E	F	G Width	H		
		650° F	750° F										
3/4	7*	950	—	0.7	15/16	5/8	27/8	27/16	3/8	1	13/8		
1			—	0.8	11/16		3	29/16			11/2		
1 1/4			—	0.8	11/4		3 1/8	211/16			11 1/16		
1 1/2	9*	1,545	1,380	2.3	113/16	1 1/16	47/8	41/8	5/8	1 1/4	23/8		
2	10*			2.6	21/8		57/8	51/8			21 1/16		
2 1/2	11*			1.97	25/8		6	53/8			3 1/4		
3	12*	2,500	2,230	2.17	27/8	5/8	65/8	6	1/2	1	3 1/2		
4	14*			6.7	33/8		75/8	6 1/2			4 1/2		
5	16*			7.0	315/16		81/8	7			5		
6	17*	2,865	2,555	7.31	47/8	1 1/4	93/8	8 1/2	3/4	2	5 3/4		
8	19*			8.33	6		103/8	9 1/2			6 7/8		
10	22*			19.8	67/8		12	107/16			8 1/4		
12	23"	3,240	2,890	22.3	77/8	1 7/16	13	117/16	1	2 1/2	9 1/4		
14	20			37.7	91/16		145/16	1211/16			10 11/16		
16	15			4,300	3,835		41.4	101/16			2	155/16	1311/16
18		44.9	111/16			165/16	1411/16	12 11/16					
20		12	5,490			4,900	57.3	123/8	175/8	155/8		13/8	14
24	12	4,500	4,015	65.9	143/8	2 1/4	193/8	177/8	1 1/4	4	16		
28	—	6,000	—	112.3	17 1/2		24 1/4	21 3/4			1 1/4	5	20
30	9	7,500	—	150.0	18 1/2		26 1/8	23 3/8			1 3/8	6	21 1/4
32	—	8,250	—	193.3	19 5/8	2 1/2	28	25	1 1/2	5	22 5/8		
34	—	9,800	—	248.8	21 1/2		31 1/4	27 3/4			1 3/4	5	25
36	—	10,500	—	257.5	22 1/2		32 1/4	28 3/4					26

Clamps may be furnished with square ends. "Span" represents the maximum recommended distance between hangers on a continuous and straight run of horizontal standard weight steel pipe filled with water. In all cases, verify that chosen location of hangers does not subject hangers to a load greater than the maximum recommended load shown above. *Indicates that span represents the maximum span for water filled pipe as given in Table 1 of page 225. For vapor service, the presence of fittings or insulation, and other weights and types of pipe, spans may either increase or decrease. In all cases, verify that chosen location of hanger does not subject hangers to a load greater than the maximum recommended load shown.

Fig. 295A

Alloy Double Bolt Pipe Clamp

Size Range: 1½" through 24"

Material: Chrome molybdenum steel (ASTM A 387 Grade 22).

Service: Recommended for suspension of high temperature pipe requiring insulation.

Maximum Temperature: 1,050° F

Approvals: Complies with Federal Specification A-A-1192A (Type 3)

WW-H-171-E (Type 3), ANSI/MSS SP-69 and MSS SP-58 (Type 3).

Features:

- Sizes 6" and above accommodate up to 4" thick insulation.
- Figure 41SD will accommodate larger insulation thicknesses, loads and dimensions.

Ordering: Specify pipe size, figure number and name.

Note: Galvanizing is not recommended for alloy products.

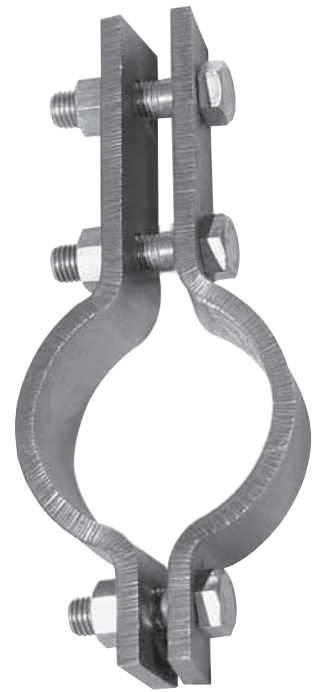
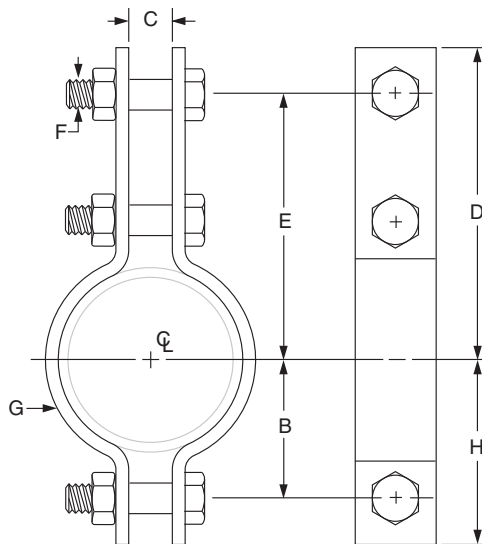

Note: This picture is representative of a typical Figure 295A. Distance between clamp ears beneath pipe may or may not be equal to upper gap.

FIG. 295A: LOADS (LBS) • WEIGHT (LBS) • DIMENSIONS (IN)

Pipe Size	Max Load ■ For Service Temp				Weight	B	C	D	Rod Take Out E	F	G Width	H
	650° F	750° F	1,000° F	1,050° F								
1½	1,545	1,410	1,000	745	2.3	1 ¹³ / ₁₆	1 ¹ / ₁₆	4 ⁷ / ₈	4 ¹ / ₈	5 ⁵ / ₈	1 ¹ / ₄	2 ³ / ₈
2					2.6	2 ¹ / ₈		5 ⁵ / ₈	5 ¹ / ₈			2 ¹¹ / ₁₆
2½					2.7	2 ⁵ / ₁₆		6 ¹ / ₈	5 ³ / ₈			2 ¹⁵ / ₁₆
3					3.0	2 ³ / ₄		6 ¹¹ / ₁₆	5 ¹⁵ / ₁₆			3 ¹ / ₂
4					6.7	3 ³ / ₈		7 ⁵ / ₈	6 ¹ / ₂			4 ¹ / ₂
5	2,500	2,290	1,625	1,200	7.0	3 ¹⁵ / ₁₆	1 ⁷ / ₁₆	8 ¹ / ₈	7	3 ³ / ₄	2	5
6					11.5	4 ³ / ₄		9 ¹⁵ / ₁₆	8 ⁹ / ₁₆			6 ¹ / ₈
8					13.2	5 ³ / ₄		10 ¹⁵ / ₁₆	9 ⁹ / ₁₆			7 ⁷ / ₈
10	3,240	2,970	2,100	1,565	19.8	7 ¹ / ₁₆	1 ⁷ / ₁₆	12	10 ⁵ / ₈	1	2 ¹ / ₂	8 ¹ / ₄
12					22.3	8 ¹ / ₁₆		13	11 ⁵ / ₈			9 ⁵ / ₁₆
14	4,300	3,915	2,795	2,060	37.7	9 ¹ / ₁₆	2	14 ⁵ / ₁₆	12 ¹ / ₁₆	1 ¹ / ₄	3	10 ¹ / ₁₆
16					41.4	10 ¹ / ₁₆		15 ⁵ / ₁₆	13 ¹ / ₁₆			11 ¹ / ₁₆
18					44.9	11 ¹ / ₁₆		16 ⁵ / ₁₆	14 ¹ / ₁₆			12 ¹ / ₁₆
20					57.3	12 ³ / ₈		17 ¹ / ₂	15 ⁷ / ₈			14
24	65.9	14 ³ / ₈	19 ¹ / ₂	17 ⁷ / ₈	1 ³ / ₈	16						

■ Based on the allowable stresses shown in the ASME Code for Pressure Piping.



STEEL PIPE CLAMPS

Fig 295H

Heavy Duty Double Bolt Pipe Clamp

Size Range: 6" through 36"

Material: Carbon steel

Finish: Plain or Galvanized

Service: Recommended for suspension of pipe requiring insulation within the limitation of temperature and loads shown below.

Maximum Temperature: Plain 750° F, Galvanized 450° F

Approvals: Complies with Federal Specification A-A-1192A (Type 3) WW-H-171-E (Type 3), ANSI/MSS SP-69 and MSS SP-58 (Type 3).

Features:

- Accommodates up to 4" thick insulation.
- Figure 41SD will accommodate larger insulation thicknesses, loads and dimensions.

Ordering: Specify pipe size, figure number, name and finish.



Note: This picture is representative of a typical Figure 295H. Distance between clamp ears beneath pipe may or may not be equal to upper gap.

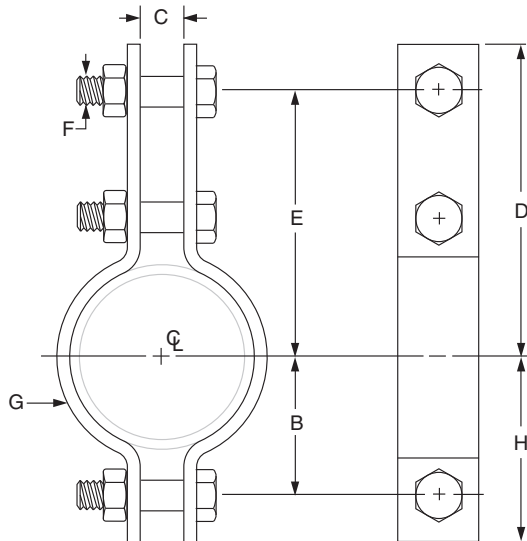

FIG 295H: LOADS (LBS) • WEIGHT (LBS) • DIMENSIONS (IN)

Pipe Size	Max Load For Service Temp		Weight	B	C	D	Rod Take Out E	F	G Width	H
	650° F	750° F								
6	3,500	3,125	12.0	4 ³ / ₄	1 ³ / ₄	10 ¹³ / ₁₆	8 ¹⁵ / ₁₆	1	2 ¹ / ₂	6
8	4,800	4,285	18.5	6	2	11 ³ / ₈	10 ¹ / ₈	1 ¹ / ₈		7 ¹ / ₄
10	5,500	4,910	30.3	7 ¹ / ₄	2 ¹ / ₄	13 ³ / ₈	11 ³ / ₈	1 ¹ / ₄	3 ¹ / ₂	9
12	7,000	6,250	42.0	8 ⁵ / ₈	2 ¹ / ₂	14 ⁵ / ₁₆	12 ⁹ / ₁₆	1 ³ / ₈		10 ³ / ₈
14	9,500	8,485	60.0	9 ⁵ / ₈		3	15 ¹ / ₂	13 ¹ / ₂	1 ¹ / ₂	4
16	10,000	8,930	80.0	10 ⁷ / ₈	3 ¹ / ₂		17 ⁷ / ₈	14 ⁷ / ₈	1 ³ / ₄	4 ¹ / ₂
18	13,800	12,325	115.0	12 ¹ / ₂		4	18 ¹ / ₄	16 ¹ / ₄	2	4
20	15,300	13,665	140.0	13 ¹ / ₂	4 ¹ / ₄		19 ³ / ₄	17 ¹ / ₄		2 ¹ / ₄
24	16,300	14,555	190.0	15 ¹ / ₂		4 ¹ / ₂	22 ⁵ / ₁₆	19 ⁵ / ₁₆	2 ¹ / ₂	
28	18,000	–	354.0	18 ⁷ / ₈	4 ¹ / ₂		31 ³ / ₄	27 ¹ / ₄		2 ¹ / ₂
30	20,500	–	406.0	19 ⁷ / ₈		4 ¹ / ₂	32 ³ / ₄	28 ¹ / ₄	2 ¹ / ₂	
32	23,750	–	555.0	21 ³ / ₄	4 ¹ / ₂		36	31		2 ¹ / ₂
34	25,000	–	604.0	23 ³ / ₈		4 ¹ / ₂	37 ¹ / ₂	32 ¹ / ₂	2 ¹ / ₂	
36	28,000	–	678.0	24 ³ / ₈	4 ¹ / ₂		40 ¹ / ₄	34 ³ / ₄		2 ³ / ₄

Clamps may be furnished with square ends.

Fig. 224

Alloy Steel Pipe Clamp

Size Range: 4" through 16"

Material: Chrome molybdenum steel except U-bolt which is stainless steel.

Service: Recommended for suspension of high temperature pipe requiring up to 4" of insulation.

Maximum Temperature: 1,050° F

Approvals: Complies with Federal Specification A-A-1192A (Type 2) WW-H-171-E (Type 2), ANSI/MSS SP-69 and MSS SP-58 (Type 2).

Installation: Normally used with welded eye rod Fig. 278, see page 93, or weldless eye nut Fig. 290, see page 97.

Features:

- Designed for the support of loads at temperatures up to 1,050° F.
- Designed to satisfy most critical engineering specifications.
- Yoke has rugged cross sectional area, eliminating high stress conditions.
- When used on pipe with 4" of insulation the top bolt is outside of the insulation.

Ordering: Specify pipe size, figure number and name.

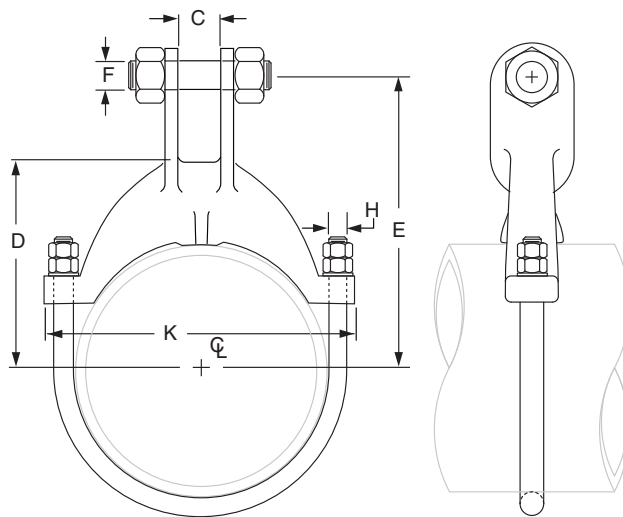
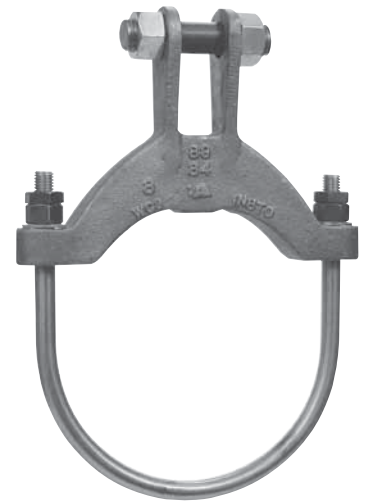

FIG. 224: LOADS (LBS) • WEIGHT (LBS) • DIMENSIONS (IN)

Pipe Size	Max Load ■				Weight	C	D	Rod Take Out E	F	H	K
	750° F	950° F	1,000° F	1,050° F							
4	3,780	3,300	2,770	1,890	4.0	1 ¹ / ₁₆	3 ³ / ₈	6 ³ / ₄	7 ⁷ / ₈	1 ¹ / ₂	6 ¹ / ₂
6	6,060	5,290	4,440	3,030	7.5	1 ⁷ / ₁₆	5 ⁵ / ₁₆	8 ⁵ / ₁₆	1	5 ⁵ / ₈	9 ¹ / ₈
8							6 ¹ / ₁₆	9 ⁹ / ₁₆			11 ¹ / ₈
10	9,060	7,910	6,640	4,420	15.8		8 ³ / ₈	10 ⁷ / ₈			1 ¹ / ₈
12	12,570	10,980	9,015	6,010	24.3	1 ¹⁵ / ₁₆	10 ¹⁰ / ₈	12 ⁷ / ₈	1 ¹ / ₂	7 ⁷ / ₈	16 ¹ / ₈
14					26.3		11 ¹ / ₈	13 ³ / ₈			17 ⁷ / ₈
16					31.0		12 ¹ / ₄	15			19 ³ / ₈

■ Based on the allowable stresses shown in the ASME Code for Pressure Piping. Over tightening of nuts may overstress U-bolts reducing the load rating. Installation tag attached to clamp gives proper nut tightening.

- Pictorial Table of Contents
- General Notes
- Copper Tubing Hangers
- CPVC Pipe Hangers
- Pipe Rings
- Clevis Hangers
- Steel Pipe Clamps**
- Socket Clamps
- Beam Clamps
- Structural Attachments
- Brackets
- Ceiling Plates & Flanges
- Concrete Inserts & Attachments
- Hanger Rods
- Rod Attachments
- Bolts, Nuts, Pins & U-Bolts

STEEL PIPE CLAMPS

Fig. 246

Heavy Duty Alloy Steel Pipe Clamp

Size Range: 10" through 24"

Material: Chrome molybdenum steel except U-bolt which is stainless steel.

Service: Recommended for suspension of high temperature pipe requiring up to 6" of insulation.

Maximum Temperature: 1,075° F

Approvals: Complies with Federal Specification A-A-1192A (Type 2), WW-H-171-E (Type 2), ANSI/MSS SP-69 and MSS SP-58 (Type 2).

Installation: Normally used with welded eye rod Fig. 278, page 93 or weldless eye nut Fig. 290, page 97.

Features:

- Designed for the support of heavy loads at high temperatures.
- Clamp with filler plate will snugly hold pipe of non-standard size.
- Alloy load distribution strap provided.
- When used on pipe with 6" of covering, the top bolt is outside of the insulation.

Ordering: Specify nominal pipe size and exact O.D. of pipe, figure number, name. Special alloy filler plates will be provided, at an extra charge, when the O.D. of the pipe size is other than standard. Installation instructions are attached to the clamp when the filler plates are required.

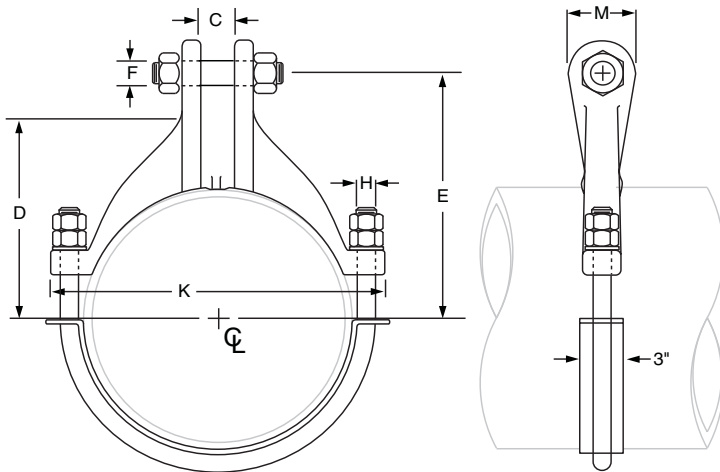
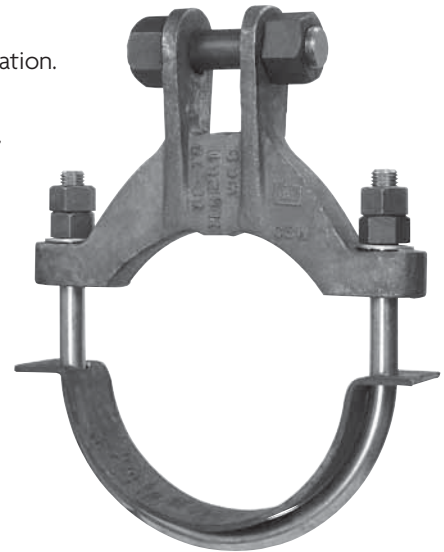

FIG. 246: LOADS (LBS) • WEIGHT (LBS) • DIMENSIONS (IN)

Pipe Size	Used on O.D. pipe size	Max Load ■				Weight*	C	D	Rod Take Out E	F	H	K	M
		950° F	1,000° F	1,050° F	1,075° F								
10	8¾ - 10 ¹³ / ₁₆	13,500	11,780	7,850	6,120	42.0	2	9 ⁵ / ₈	12	1½	1	15 ³ / ₈	3¼
12	10 ⁷ / ₈ - 12 ¹³ / ₁₆	16,500	14,910	9,940	7,750	58.0	2½	10 ³ / ₄	13 ³ / ₄	1 ⁵ / ₈	1¼	17 ⁷ / ₈	4
14	12 ⁷ / ₈ - 14 ¹ / ₁₆							11½	14½			19 ¹ / ₈	
16	14 ¹ / ₈ - 16 ¹ / ₁₆							13 ³ / ₈	16 ³ / ₈			21 ¹ / ₈	
18	16 ⁷ / ₈ - 18 ¹ / ₁₆	19,000	18,410	12,270	9,570	94.0	2½	14½	18¼	2	1¼	24 ¹ / ₈	4½
20	18 ⁷ / ₈ - 20 ¹ / ₁₆							15 ³ / ₄	19½			26 ¹ / ₈	
24	20 ⁷ / ₈ - 24 ¹ / ₁₆	25,000	22,280	14,850	11,580	167.0	3	18¼	22	2¼	1 ⁵ / ₈	30 ³ / ₄	6

■ Based on the allowable stresses shown in the ASME Code for Pressure Piping. Over tightening of nuts may overstress U-bolts reducing the load rating. Installation tag attached to clamp gives proper nut tightening. * This weight does not include filler plates required on non-standard pipe sizes

Fig. 595

Socket Clamp for Ductile Iron or Cast Iron Pipe

Size Range: 4" through 24"

Material: Two carbon steel half bands and four bolts and nuts.

Finish: Plain or Galvanized

Service: Clamps ductile or cast iron mechanical joint piping or mechanical joint or socket joint fittings together to prevent separation or distortion of pipe line under excessive water pressure.

Approvals: Complies with Federal Specification A-A-1192A (Type 8), ANSI/MSS SP-69 and MSS SP-58 (Type 8). Complies with the requirements of the National Fire Protection Association Standard NFPA-24 for Outside Protection.

Ordering: Specify pipe size, figure number, name and finish.

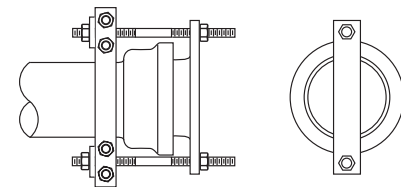
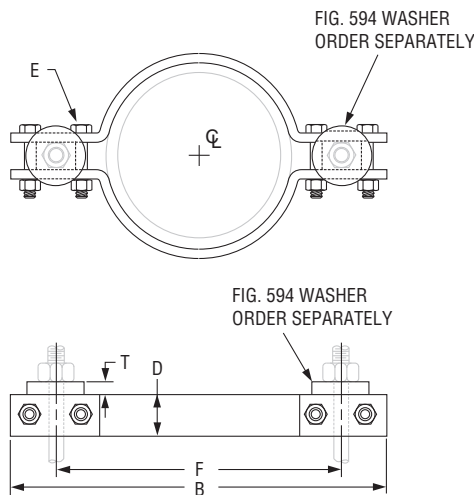

Fig. 594

Socket Clamp Washer

Two cast iron or steel washers, Fig. 594, are used with each Fig. 595 socket clamp and these must be ordered separately.

Ordering: Specify washer size, figure number, name and finish.



Plug Strap for Bell End of Pipe

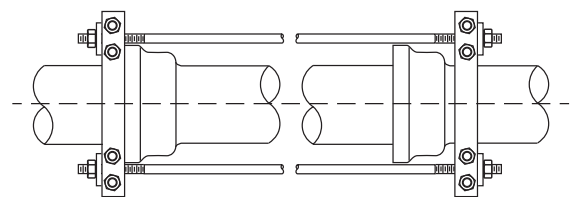

Pipe Anchor

FIG. 595, FIG. 594: LOADS (LBS) • WEIGHT (LBS) • DIMENSIONS (IN)

D.I./C.I. Pipe Size	Max Test Pressure (PSI)	Force* On Clamp	Weight		Pipe O.D.	B	D Width	Bolt Dia. E	F	T	Fig. 594 Washer Rod Dia.
			Fig. 595 Clamp	Fig. 594 Washer							
4	250	4,550	12.8	1.1	5	14 ⁵ / ₈	2	5/8	9 ⁵ / ₈	5/8	3/4
6		9,340	14.6		7 ¹ / ₈	16 ⁷ / ₈					
8		16,080	23.6		9 ⁵ / ₁₆	19 ¹ / ₈					
10		24,180	29.3	1.7	11 ¹ / ₂	21 ³ / ₈	2 ¹ / ₂	3/4	16 ⁵ / ₈		
12		34,230	40.3		13 ¹ / ₂	25 ¹ / ₈					
14	120	22,200	53.9	2.7	15 ³ / ₄	28 ¹ / ₄	3	7/8	19 ⁵ / ₈	3/4	
16	115	27,760	76.5		17 ⁷ / ₈	31 ³ / ₈					
18	100	23,900	94.3	4.3	20	35 ¹ / ₈	4	1	22 ³ / ₈		
20	75	27,500	109.8		22 ¹ / ₈	37 ³ / ₄			4 ¹ / ₂	1 ¹ / ₄	25 ³ / ₈
24	50	26,200	148.6		5.8	26 ⁵ / ₈	44 ¹ / ₄	5			1 ¹ / ₂
									36	1 ¹ / ₄	1 ¹ / ₂

*Refers to Hydrostatic Test

SOCKET CLAMPS

Fig. 600

Socket Clamp for Ductile Iron or Cast Iron Pipe

Size Range: 3" through 24" pipe

Material: Two carbon steel halfbands and two bolts and nuts.

Finish: Plain or Galvanized

Service: Clamps joints of socket fittings together to prevent distortion of pipe line under excessive water pressure.

Approvals: Complies with Federal Specification A-A-1192A (Type 8), ANSI/MSS SP-69 and MSS SP-58 (Type 8).

Features: An economical method of anchoring joints of socket fittings when used on other than fire protection work.

Ordering: Specify pipe size, figure number, name and finish.



Fig. 599

Socket Clamp Washer

Two cast iron or steel washers, Fig. 599, are used with each Fig. 600 socket clamp and these must be ordered separately.

Ordering: Specify washer size, figure number, name and finish.

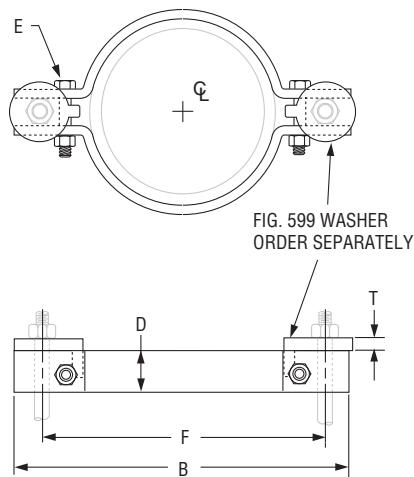

FIG. 600, FIG. 599: WEIGHT (LBS) • DIMENSIONS (IN)

D.I./C.I. Pipe Size	Weight		Pipe O.D.	B	D Width	Bolt Dia. E	F	T	Fig. 599: Washer Rod Dia.
	Fig. 600: Clamp	Fig. 599: Washer							
3	9.7	1.2	4	11 ⁵ / ₈	2	5/8	8 ⁵ / ₈	5/8	3/4
4	11.0		5	12 ¹ / ₈			9 ³ / ₄		
6	12.7		7 ¹ / ₁₆	14 ³ / ₈			12		
8	14.5		9 ³ / ₁₆	16 ⁵ / ₈			14 ¹ / ₄		
10	16.3		11 ³ / ₈	18 ⁷ / ₈			16 ¹ / ₂		
12	18.3		13 ¹ / ₂	21 ¹ / ₄			18 ³ / ₈		
14	48.7	2.7	15 ³ / ₄	25 ¹ / ₂	3	7/8	23	1 ¹ / ₈	1 ¹ / ₄
16	69.2		17 ⁷ / ₈	28	4	1	25 ¹ / ₂		
18	82.0	4.5	20	31 ¹ / ₂	4 ¹ / ₂	1 ¹ / ₄	27 ⁵ / ₈		
20	97.5		22 ¹ / ₈	33 ³ / ₄			29 ³ / ₄		
24	132.0	6.8	26 ³ / ₈	39 ³ / ₄	5	1 ¹ / ₂	35 ¹ / ₄	1 ¹ / ₄	1 ¹ / ₂

Fig. 86: C-Clamp with Set Screw and Lock Nut Fig. 88: C-Clamp with Set Screw Only

C-Clamp

Size Range: $\frac{3}{8}$ " through $\frac{3}{4}$ "

Material: Malleable iron clamp; hardened steel cup point set screw.

Finish: Plain or Galvanized

Service: Recommended for attachment to "W" and "M" beams where thickness of flange Z (see table page 234) does not exceed 0.75". When clamp is used with Fig. 89 retaining clip, flange thickness may not exceed 0.62".

Approvals: Complies with Federal Specification A-A-1192A (Type 23), WW-H-171-E (Type 23), ANSI/MSS SP-69 and MSS SP-58 (Type 23), UL, ULC Listed (Sizes $\frac{3}{8}$ ", $\frac{1}{2}$ " and $\frac{3}{4}$ ") and FM Approved (Sizes $\frac{3}{8}$ ").

Installation: Follow recommended set screw torque values per MSS-SP-69 (See table on page 233). The Fig. 88 is only to be used on installations where the clamp cannot become dislodged from the beam.

Features:

- Malleable body assures:
 - Uniform quality and strength.
 - Full thread engagement.
- Hardened steel cup point set screw for securing to beam flange.
- Ribbed design of clamp provides added strength.

Ordering: Specify rod size, figure number, name, length of retaining clip, if desired.

(Add 2" to flange width of beam to arrive at proper length of retaining clip.)

If required length is not standard, order next longer standard.



Fig. 86

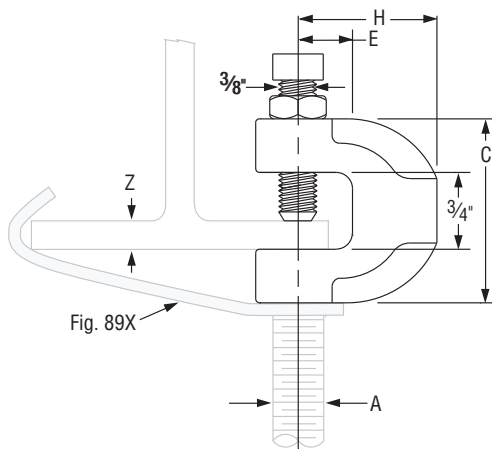

Fig. 86

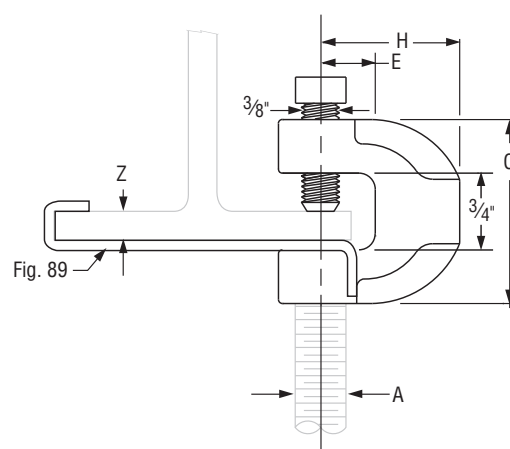

Fig. 88

FIG. 86 AND FIG. 88: LOADS (LBS) • WEIGHT (LBS) • DIMENSIONS (IN) • TORQUE (IN-LBS)

Rod Size A	Torque Value	Max Load ■	C	E	H	Weight	
						Fig. 86	Fig. 88
$\frac{3}{8}$	60	400	$1\frac{3}{4}$	$\frac{5}{8}$	$1\frac{3}{8}$	0.28	0.26
$\frac{1}{2}$	60					0.31	0.29
$\frac{5}{8}$	60	440	2	$\frac{3}{4}$	$1\frac{1}{2}$	0.42	0.40
$\frac{3}{4}$	60	500				0.55	0.53

■ Maximum temperature of 450° F.

- Pictorial Table of Contents
- General Notes
- Copper Tubing Hangers
- CPVC Pipe Hangers
- Pipe Rings
- Clevis Hangers
- Steel Pipe Clamps
- Socket Clamps
- Beam Clamps**
- Structural Attachments
- Brackets
- Ceiling Plates & Flanges
- Concrete Inserts & Attachments
- Hanger Rods
- Rod Attachments
- Bolts, Nuts, Pins & U-Bolts

Fig. 95

C-Clamp with Locknut

Size Range: $\frac{3}{8}$ " and $\frac{1}{2}$ "

Material: Carbon Steel

Finish: Plain or Galvanized

Service: Designed for fastening flange of "W" and "M" beam. Bottom hole tapped to accommodate hanger rod.

Approvals: Complies with Federal Specification A-A-1192A (Type 23) WW-H-171-E (Type 23), ANSI/MSS SP-69 and MSS SP-58 (Type 23).

UL Listed (Sizes $\frac{3}{8}$ ").

FM Approved (Sizes $\frac{3}{8}$ " - $\frac{1}{2}$ ").

Installation: Follow recommended set screw torque values per MSS-SP-69 (See table on page 233).

Ordering: Specify rod size, figure number, name and finish.

Note: If a retaining clip is desired, you may specify either Fig. 89X or Fig. 89. For length and other ordering information, refer to Fig. 89X and Fig. 89.

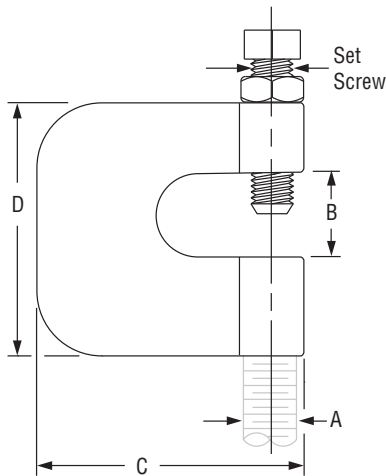
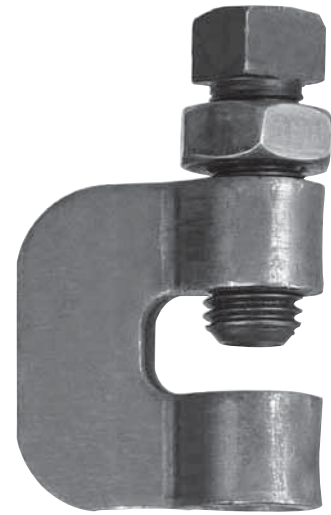

FIG. 95: LOAD (LBS) • WEIGHT (LBS) • DIMENSIONS (IN) • TORQUE (IN-LBS)								Rod Sized Retaining Clips	
Rod Size A	Set Screw Size	Torque Value	Max Load	B	C	D	Weight	Fig. 89	Fig. 89X
$\frac{3}{8}$	$\frac{3}{8}$	60	230	$\frac{3}{4}$	$2\frac{1}{4}$	$2\frac{3}{8}$	0.34	$\frac{3}{8}$	$\frac{3}{8}$
$\frac{1}{2}$	$\frac{1}{2}$	125	380				0.40		$\frac{1}{2}$

Fig. 89

Retaining Clip

Size Range: $\frac{3}{8}$ " through $\frac{1}{2}$ "

Material: Carbon steel

Finish: Plain or Galvanized

Service: For use with Figs. 86, 88 & 95. NOT for seismic applications.

How to size: Specify length of retaining strap based on beam size.

Installation: Length of strap should be adequate to allow at least 1" of strap to be bent over the beam side of the flange opposite the side the beam clamp is mounted on.

Ordering: Specify rod size, figure number, name, length of retaining clip and finish (Add 2" to flange width of beam to arrive at proper length of retaining clip).
If required length is not standard, order next longer standard.

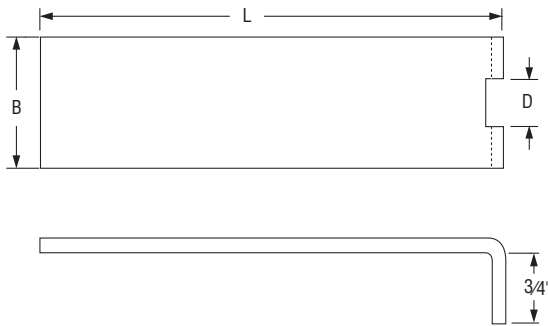
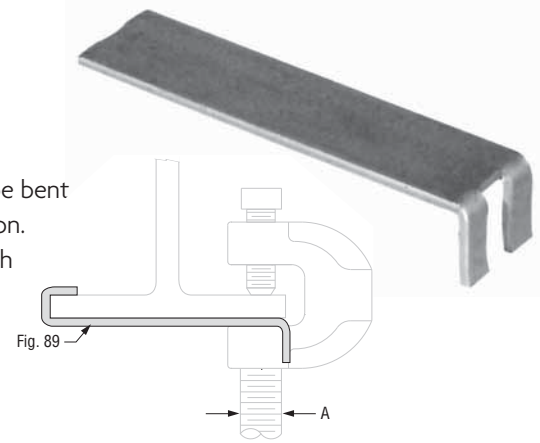

FIG. 89: RETAINING CLIP: WEIGHT (LBS) • DIMENSIONS (IN)

Rod Size A	B	D	Weights				Length L
			4½	8	10	14	
$\frac{3}{8}$	1	$\frac{7}{16}$	0.17	0.28	0.35	0.53	4½, 8, 10, 14
$\frac{1}{2}$	1¼	$\frac{15}{32}$	0.22	0.37	0.46	0.63	
$\frac{5}{8}$	1¾	$\frac{11}{16}$	0.25	0.43	0.51	0.73	
$\frac{3}{4}$							

Fig. 89X

Retaining Clip

Size Range: $\frac{3}{8}$ " through $\frac{3}{4}$ "

Material: Carbon steel

Finish: Galvanized

Service: For use with Figs. 86, 88, 92, 93, 94 & 95 in seismic applications.

Approvals: Complies with MSS-SP-127. UL and ULC Listed.

How to size: Specify length of retaining strap based on beam size.

Installation: Length of strap should be adequate to allow at least 1" of strap to be bent over the beam side of the flange opposite the side the beam clamp is mounted on.

Ordering: Specify rod size, figure number, name, length of retaining clip and finish (Add 2" to flange width of beam to arrive at proper length of retaining clip).
If required length is not standard, order next longer standard.

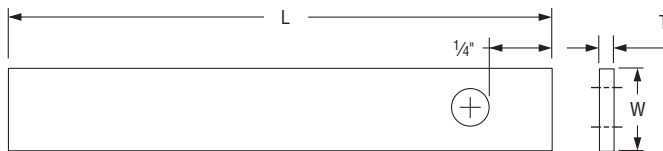

FIG. 89X: WEIGHT (LBS) • DIMENSIONS (IN)

Rod Size A	Width W	T	Weight				Length L
			6	8	10	14	
$\frac{3}{8}$	1	0.058	0.10	0.14	0.17	0.24	6, 8, 10, 14
$\frac{1}{2}$							
$\frac{5}{8}$	1¼	0.070	0.13	0.17	0.22	0.31	
$\frac{3}{4}$							

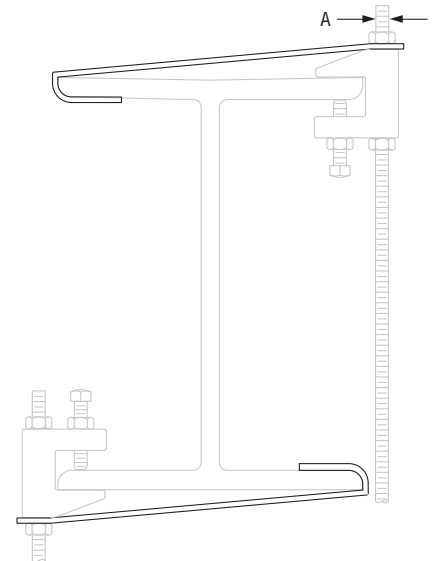

Fig. 92

Universal C-type Clamp (Standard Throat)

Size Range: $\frac{3}{8}$ " and $\frac{1}{2}$ "

Material: Ductile iron, hardened steel cup point set screw and locknut.

Finish: Plain or Galvanized

Service: Recommended for use under roof installations with bar joist type construction, or for attachment to the top or bottom flange of structural shapes where the vertical hanger rod is required to be offset from the edge of the flange and where the thickness of joist or flange does not exceed $\frac{3}{4}$ ".

Approvals: Complies with Federal Specification A-A-1192A (Type 19 & 23) WW-H-171-E (Type 23), ANSI/MSS SP-69 and MSS SP-58 (Type 19 & 23).

UL, ULC Listed and FM Approved.

How to size: Size of clamp is determined by size of rod to be used.

Installation: Follow recommended set screw torque values per MSS-SP-69 (See table on page 233)

Features:

- They may be attached to horizontal flanges of structural members in either the top beam or bottom beam positions.
- Secured in place by a cup-pointed Set Screw tightened against the flange. A Jam Nut is provided for tightening the Set Screw against the Body Casting.
- Thru tapping of the body casting permits extended adjustment of the threaded rod.
- Can be used with Fig 89X retaining clip for seismic applications.

Ordering: Specify rod size, figure number, name of clamp and finish.

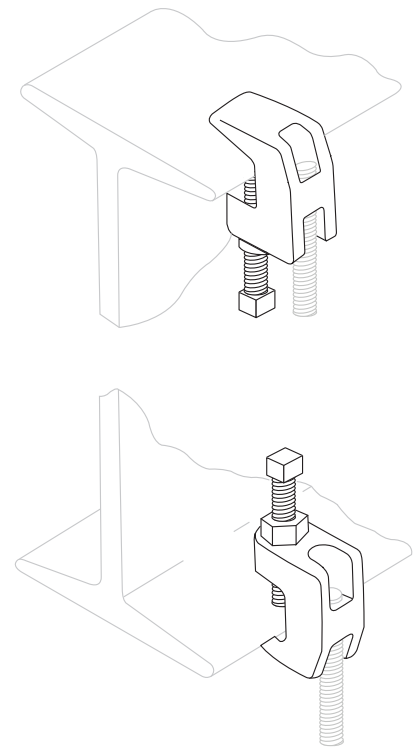
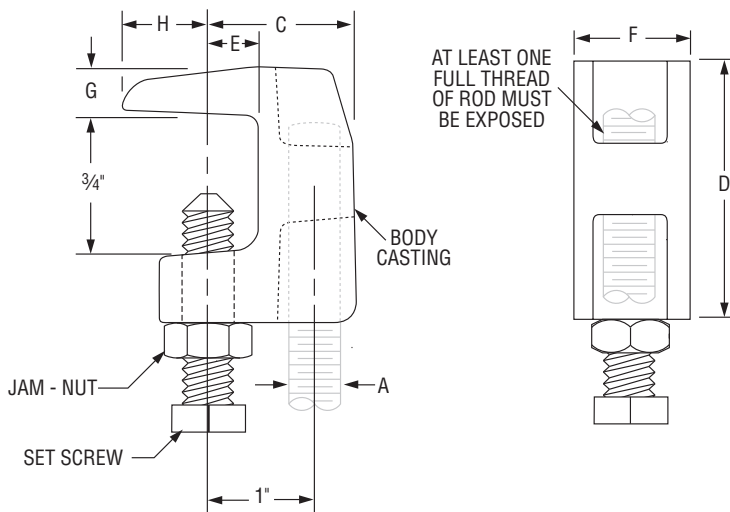

FIG. 92: LOAD (LBS) • WEIGHT (LBS) • DIMENSIONS (IN) • TORQUE (IN-LBS)											
Rod Size A	Set Screw Size	Torque Value	Max Loads ■		Weight	C	D	E	F	G	H
			Top	Bottom							
$\frac{3}{8}$	$\frac{3}{8}$	60	500	250	0.34	$1\frac{1}{16}$	$1\frac{1}{16}$	$\frac{9}{16}$	$1\frac{3}{16}$	$\frac{3}{8}$	$\frac{1}{2}$
$\frac{1}{2}$	$\frac{1}{2}$	125	950	760	0.63	$1\frac{3}{8}$	$1\frac{13}{16}$	$\frac{1}{2}$	$1\frac{1}{16}$	$\frac{7}{16}$	$\frac{23}{32}$

■ Maximum temperature of 450° F

Fig. 93

Universal C-type Clamp (Wide Throat)

Size Range: $\frac{3}{8}$ " and $\frac{1}{2}$ "

Material: Ductile iron clamp, hardened steel cup point set screw and locknut.

Finish: Plain and Galvanized

Service: Recommended for use under roof installations with bar joist type constructions, or for attachment to the top or bottom flange of structural shapes where the vertical hanger rod is required to be offset from the edge of the flange and where the thickness of joist or flange does not exceed $1\frac{1}{4}$ ".

Approvals: Complies with Federal Specification A-A-1192A (Type 19 & 23), WW-H-171-E (Type 23), ANSI/MSS SP-69 and MSS SP-58 (Type 19 & 23). UL, ULC Listed and FM Approved.

How to size: Size of clamp is determined by size of rod to be used.

Installation: Follow recommended set screw torque values per MSS-SP-69 (See tables on page 233).

Features:

- They may be attached to horizontal flanges of structural members in either the top beam or bottom beam positions.
- Secured in place by a cup-pointed Set Screw tightened against the flange. A Jam Nut is provided for tightening the Set Screw against the Body Casting.
- Thru tapping of the body casting permits extended adjustment of the threaded rod.
- Wider throat for attaching to flange with up to $1\frac{1}{4}$ " thickness.

Ordering: Specify rod size, figure number, name of clamp and finish.

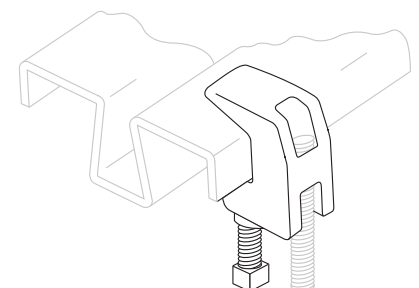
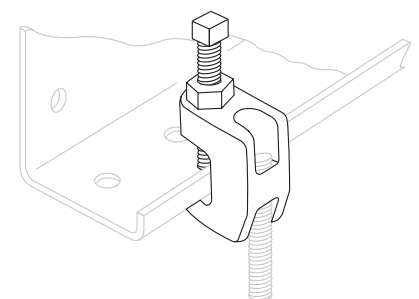
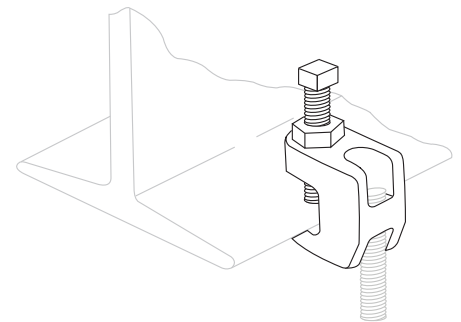
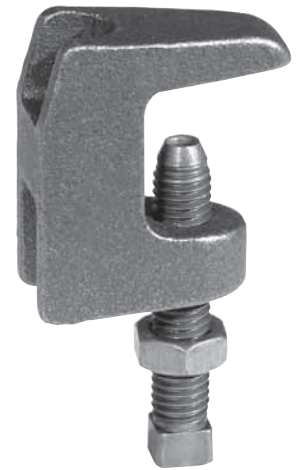
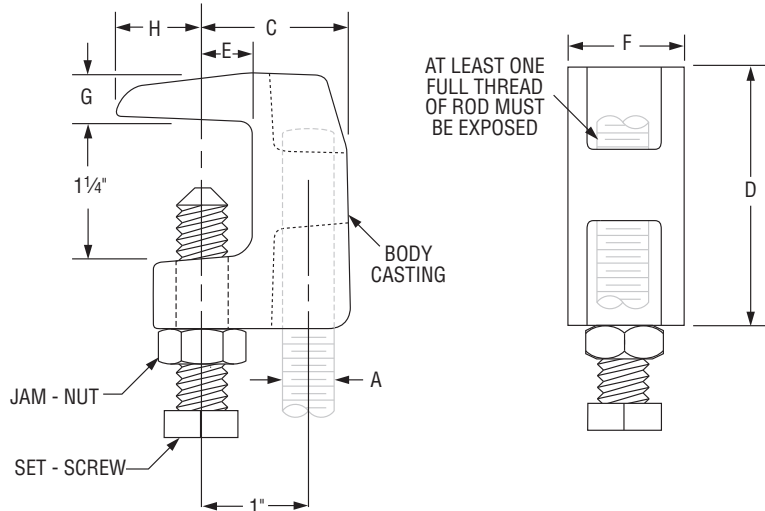

FIG. 93:
LOAD (LBS) • WEIGHT (LBS) • DIMENSIONS (IN) • TORQUE (IN-LBS)

Rod Size A	Set Screw Size	Torque Value	Max Loads ■		Weight	C	D	E	F	G	H
			Top	Bottom							
$\frac{3}{8}$	$\frac{3}{8}$	60	500	250	0.41	$1\frac{5}{16}$	$2\frac{5}{32}$	$\frac{9}{16}$	$1\frac{3}{16}$	$\frac{3}{8}$	$\frac{5}{8}$
$\frac{1}{2}$	$\frac{1}{2}$	125	950	760	0.75	$1\frac{3}{8}$	$2\frac{11}{32}$	$\frac{1}{2}$	$1\frac{1}{16}$	$\frac{7}{16}$	$1\frac{13}{16}$

■ Maximum temperature of 450° F

Fig. 94

Wide Throat Top Beam C-Clamp

Size Range: $\frac{5}{8}$ " and $\frac{3}{4}$ "

Material: Ductile iron body, hardened steel cup point set screw and locknut.

Finish: Plain or Galvanized

Service: Recommended for use under roof installations with bar joist type construction, or for attachment to the top flange of structural shapes where the vertical hanger rod is required to be offset from the edge of the flange and where the thickness of joists or flange does not exceed $1\frac{5}{16}$ ".

Approvals: Complies with Federal Specification A-A-1192A (Type 19) WW-H-171-E (Type 19), ANSI/MSS SP-69 and MSS SP-58 (Type 19), UL Listed.

How to size: Size of clamp is determined by size of rod to be used.

Installation: Follow maximum recommended set screw torque values per MSS-SP-69. (See tables on page 233)

Features:

- Provides clamping to bar joists which are directly under roof installations.
- Provides for vertical hanger rod installed offset from the edge of the beam flange.
- Malleable iron body assures full thread engagement of rod.

Ordering: Specify rod size, figure number, name of clamp and finish.

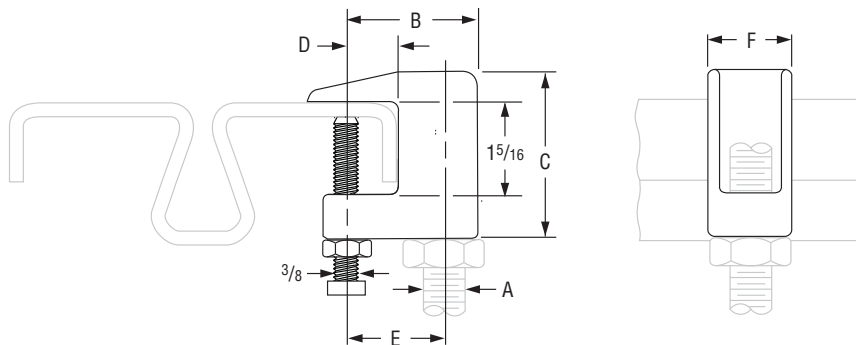
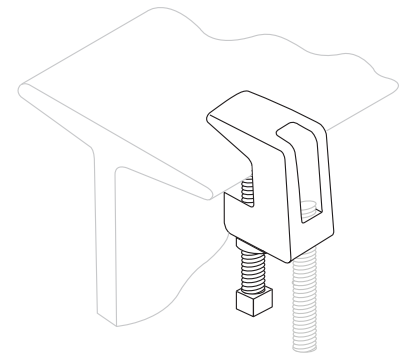
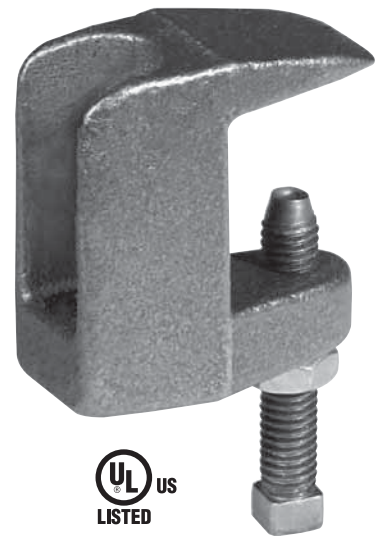

FIG. 94: LOAD (LBS) • WEIGHT (LBS) • DIMENSIONS (IN) • TORQUE (IN-LBS)									
Rod Size A	Set Screw Size	Torque Value	Max Loads ■	Weight	B	C	D	E	F
$\frac{5}{8}$	$\frac{3}{8}$	60	1,200	0.66	$1\frac{3}{4}$	$2\frac{1}{4}$	$\frac{3}{4}$	$1\frac{1}{4}$	1
$\frac{3}{4}$	$\frac{3}{8}$	60	1,600	0.83	$1\frac{7}{8}$	$2\frac{3}{8}$		$1\frac{3}{8}$	$1\frac{1}{16}$

■ Maximum temperature of 450° F

Fig. 227

Top Beam Clamp

Material: Carbon steel jaw, hook rod with nut, lock washer and plain washer.

Finish: Plain

Service: Recommended for use on top flange of beam and roof trusses where the flange thickness does not exceed 0.81".

Approvals: Complies with Federal Specification A-A-1192A (Type 25), ANSI/MSS SP-69 and MSS SP-58 (Type 25). UL Listed (rod sizes $\frac{3}{8}$ " & $\frac{1}{2}$ ") and FM Approved when used with $\frac{3}{8}$ " rod size.

How to size: Determine hook rod length by adding figure in column headed "x" to flange width (see table on page 234 for flange width). "x" is not indicated as a dimension on drawing.

Installation: Slide stamped steel jaw over beam flange and attach hook rod and eye rod, finally tightening hook rod. Hammer jaw firmly against the underside of the beam to complete installation.

Features:

- Two jaw sizes fit beam flanges thickness from 0.25" to 0.81".
- Clamp firmly holds to beam providing safe and extremely economical means of supporting small piping from the top flange of steel beams and roof trusses.

Ordering: Specify jaw size, figure number, name, hook rod length. Standard hook rods are furnished in even inch lengths, either length ordered or next longer length.

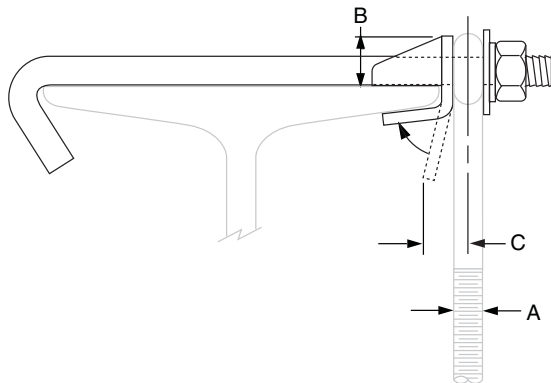

FIG. 227: LOADS (LBS) • WEIGHT (LBS) • DIMENSIONS (IN)

Jaw Size	Max Load	Weight ▲	Hook Rod Diam	Rod Size A	B	C	X
1	730	0.38	$\frac{3}{8}$	$\frac{3}{8}$	$\frac{3}{4}$	$\frac{5}{16}$	$2\frac{1}{8}$
2	940	0.67	$\frac{1}{2}$	$\frac{1}{2}$	1	$\frac{3}{8}$	$2\frac{1}{4}$
				$\frac{5}{8}$	$1\frac{1}{8}$	$\frac{7}{16}$	$2\frac{1}{2}$
				$\frac{3}{4}$	$1\frac{1}{4}$	$\frac{1}{2}$	$2\frac{5}{8}$

▲ Based on 8" hook rod length. Will vary for other hook rod lengths.

Fig. 14

Adjustable Side Beam Clamp

Size Range: 3/8" through 5/8"

Material: Carbon steel

Finish: Plain or Galvanized

Service: Recommended for supporting pipe from the bottom flange of beam

Approvals: Complies with Federal Specification A-A-1192A (Type 27)

WW-H-171-E (Type 54), ANSI/MSS SP-69 and MSS SP-58 (Type 27).

Ordering: Specify rod size, figure number, name and finish.

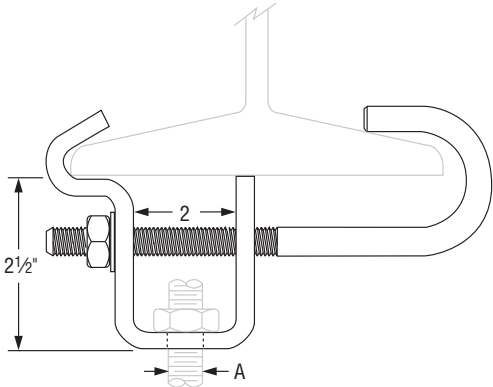
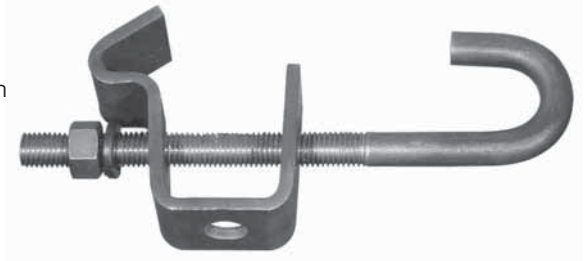

FIG. 14: LOAD (LBS) • WEIGHT (LBS) • DIMENSIONS (IN)

Rod Size A	Max Load	Hole Size A	Adjustment Beam Width		Weight
			Min.	Max.	
3/8	300	7/16	3 1/2	8	1.19
1/2	700	9/16			1.67
5/8	1,000	1 1/16			2.23

Fig. 217

Adjustable Side Beam Clamp

Size Range: 3" through 7 5/8"

Material: Carbon steel

Finish: Plain

Service: To be used where it is necessary for the hanger rod to run vertically close to the beams edge, eliminating drilling of holes in structural members.

Components: Top slide, bottom hook, nut and bolt – assembled.

Design: Can be adjusted to fit various beam flange widths and thicknesses.

Approvals: Complies with Federal Specification A-A-1192A (Type 25), ANSI/MSS SP-69 and MSS SP-58 (Type 25).

Ordering: Specify size, figure number, type, name.

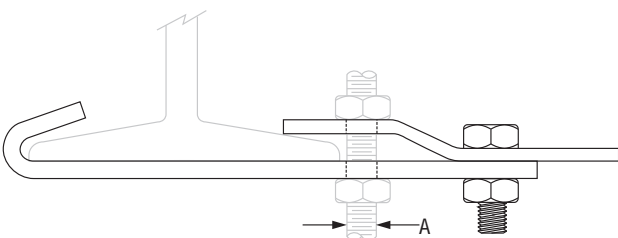

FIG. 217: LOAD (LBS) • WEIGHT (LBS) • DIMENSIONS (IN)

Size	Max Flange Width	Max Flange Thickness	Rod Size A	Max Load	Weight
Fig. 217 - Type 1					
3	3 - 4 1/2	1/2	3/8	300	0.80
4 5/8	4 5/8 - 6	1 1/16			1.06
6 1/8	6 1/8 - 7 1/2	3/4			1.17
7 5/8	7 5/8 - 9	1 5/16			1.28
Fig. 217 - Type 2					
3	3 - 4 1/2	1/2	1/2	500	1.57
4 5/8	4 5/8 - 6	1 1/16			1.84
6 1/8	6 1/8 - 7 1/2	3/4			2.05
7 5/8	7 5/8 - 9	1 5/16			2.23
Fig. 217 - Type 3					
3	3 - 4 1/2	1/2	5/8	700	3.75
4 5/8	4 5/8 - 6	1 1/16			4.19
6 1/8	6 1/8 - 7 1/2	3/4			4.53
7 5/8	7 5/8 - 9	1 5/16			5.11

Fig. 133 Fig. 134

Size Range: 4" through 12"

Material: Carbon steel

Finish: Plain or Galvanized

Service: Clamp centers the load on beam to prevent distortion

Approvals: Complies with Federal Specification A-A-1192A (Type 21) WW-H-171-E (Type 21), ANSI/MSS SP-69 and MSS SP-58 (Type 21).

Fig. 133 UL Listed when used with $\frac{3}{8}$ " and $\frac{1}{2}$ " rod.

Fig. 134 UL Listed and FM Approved when used with $\frac{1}{2}$ " and $\frac{5}{8}$ " rod.

Components: Two half-clamps, pipe spacer and bolt with nut assembled.

Ordering: Figure number, width of flange, name and finish.

Note: Spacer is furnished for use with Fig. 290 weldless eye nuts. Spacer may be removed for use with Fig. 278 eye rods.

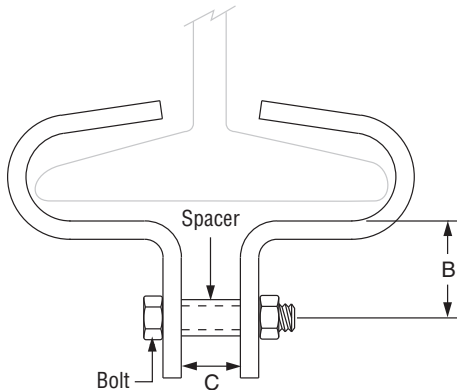

Flange Size			
Flange Width	Max Flange Thickness	Weight (lbs)	
		Fig. 133 Std. Duty	Fig. 134 Heavy Duty
4	$\frac{1}{2}$	0.91	3.82
5	$\frac{3}{8}$	1.00	4.35
6	$\frac{3}{4}$	1.15	4.52
7	$\frac{7}{8}$	1.29	4.84
8		1.44	5.10
9	1	—	5.83
10		—	6.25
11		—	6.67
12		—	7.09

Standard Duty Beam Clamp Heavy Duty Beam Clamp

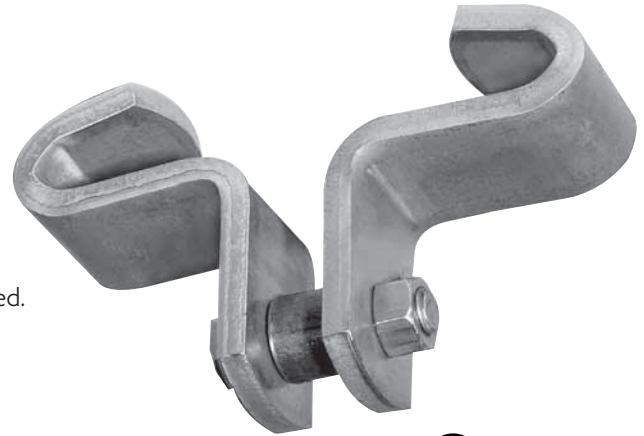

Fig. 133
Standard Duty

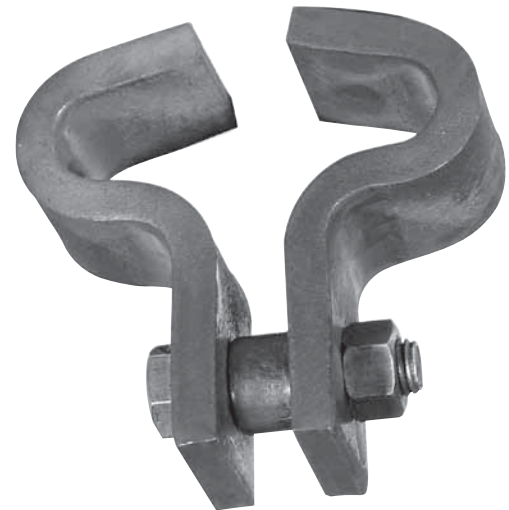

Fig. 134
Heavy Duty



FIG. 133, 134: LOADS (LBS) • DIMENSIONS (IN)					
	C	B	Bolt Size	Spacer O.D.	Max Load
Fig. 133	$\frac{1}{2}$	$1\frac{3}{8}$	$\frac{3}{8}$	$1\frac{1}{16}$	1,000
Fig. 134	$\frac{3}{4}$	$2\frac{1}{4}$	$\frac{5}{8}$	$1\frac{1}{16}$	3,000

- Pictorial Table of Contents
- General Notes
- Copper Tubing Hangers
- CPVC Pipe Hangers
- Pipe Rings
- Clevis Hangers
- Steel Pipe Clamps
- Socket Clamps
- Beam Clamps**
- Structural Attachments
- Brackets
- Ceiling Plates & Flanges
- Concrete Inserts & Attachments
- Hanger Rods
- Rod Attachments
- Bolts, Nuts, Pins & U-Bolts

Fig. 218

Malleable Beam Clamp without Extension Piece

Material: Malleable iron jaw, steel tie rod, nuts and washer.

Finish: Plain or Galvanized

Service: Recommended for attachment to structural steel.

Use in conjunction with beams where beam widths are from 2 3/8" minimum to 7" maximum and flange thickness does not exceed 0.60".

Approvals: Complies with Federal Specification A-A-1192A (Type 30) WW-H-171-E (Type 30), ANSI/MSS SP-69 and MSS SP-58 (Type 30). UL, ULC Listed (Sizes 3/4" - 12" pipe size, when used with the Fig. 157 extension piece 3/8" - 7/8" rod sizes).

FM Approved (Sizes 3/4" - 4" pipe size, when used with the Fig. 157 extension piece 3/8" rod size).

Installation: The malleable beam clamp Fig. 218 may be used with an eye rod, or Fig. 157 extension piece.

Features:

- Functional design insures proper fit for all beam sizes.
- Tie rod locks clamp in place when nuts are tightened.
- Ordering and stocking simplified because of one universal size.
- Design allows hanger rod to swing from vertical providing flexibility at the beam clamp.

Ordering: Specify figure number, name and finish.

Note: When used with Fig. 157 see page 97 extension piece, an additional inch or more of vertical adjustment is obtained.

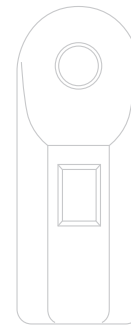
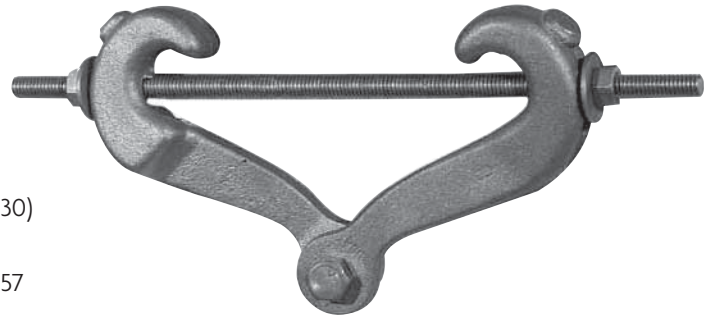

Fig. 157 (not supplied)

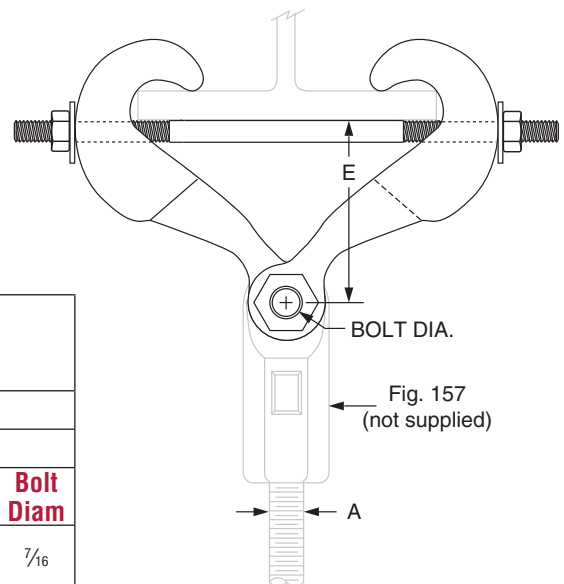

FIG. 218: LOADS (LBS) • WEIGHT (LBS) • DIMENSIONS (IN)										
Max Rod Size A	Max Load ■	Weight	Width of Beam Flange (in)							Bolt Diam
			Rod Take Out - E (in)							
			2 3/8	3	4	5	6	7		
7/8	1,365	2.2	3 1/2	3 7/16	3 5/16	2 15/16	2 9/16	1 7/8	7/16	

■ Note: see page 233 for load capacity of rod.

Fig. 228

Universal Forged Steel (UFS) Beam Clamp with UFS (Upper) Nut Right-Hand Thread

Material: Forged steel

Finish: Plain or Galvanized

Service: For suspension of heavy loads from beams with flange widths to 15" and flange thickness to 1.031.

Approvals: Complies with Federal Specification A-A-1192A (Type 28 without links; Type 29 with links), WW-H-171-E (Type 30 & 31), ANSI/MSS SP-69 and MSS SP-58 (Type 28 without links; Type 29 with links).

Installation: Fit jaws over edges of lower beam flange and tighten nuts on tie rod to lock clamp in place.

Features:

- Upper nut is tapped to any specified size up to the maximum rod size.
- Quickly, easily, economically installed.
- Tie rod insures a tight non-slip fit to the beam.
- Clamps are available, tapped to any specified rod size up to the maximum rod size.

Ordering: Specify clamp size, figure number, name, rod size and finish.

Note: The application of a load to a structural beam by means of a beam clamp produces a transverse stress, perpendicular to the axis of the beam, in the flange to which the load is applied.

Size per load, beam flange width and rod size

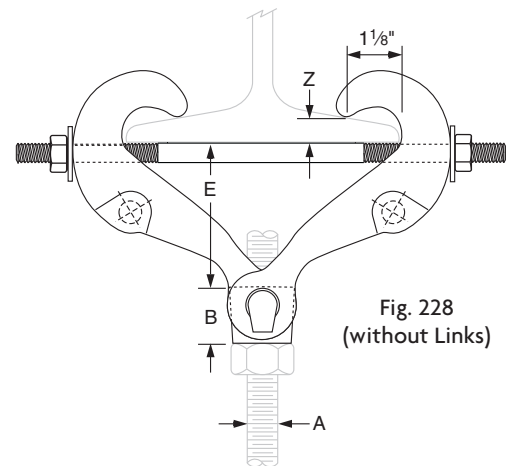
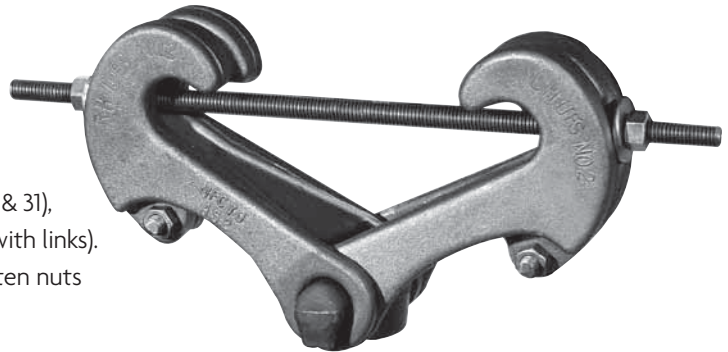

Fig. 228 (without Links)

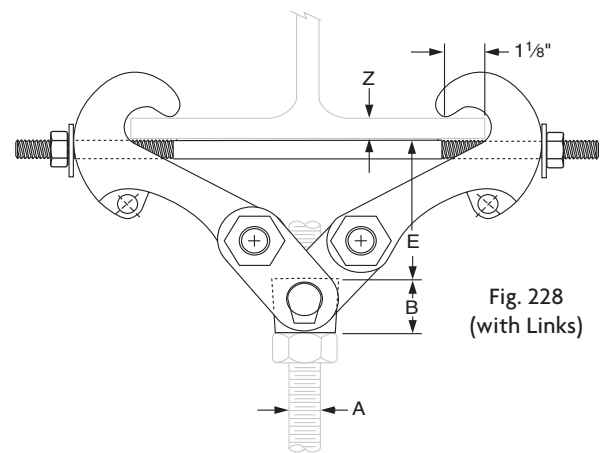

Fig. 228 (with Links)

FIG. 228: LOADS (LBS) • WEIGHT (LBS) • DIMENSIONS (IN)						
Clamp Size No.	Max Rod Size A	Max Load ■	Weight	Z Max ❖	B	Jaw and Nut Size ▲
1	5/8	2,160	3.3	0.60	1 1/16	228 - 1
2	7/8	4,480	7.0		1 3/8	228 - 2
3•		11,500	10.6	2 3/8	228 - 3	
4	1 1/2	19.3	1.031			
5•		31.0				

▲ For reference only, order by clamp size.

• Furnished with links.

■ Note: Load capacity based on rod sizes shown. For load capacity of other rod sizes see page 233.

❖ For actual "Z" dimensions see table on page 234.

Clamp Size No.	Width of Beam Flange (in)													
	Rod Take Out - E (in)													
	3	4	5	6	7	8	9	10	11	12	13	14	15	
1	1 9/16	1 1/2	1 5/16	1 1/8	3/4	-	-	-	-	-	-	-	-	-
2	-	1 7/16			1 1/16	-	-	-	-	-	-	-	-	-
3•	-	-	-	-	1 15/16	1 13/16	1 1/2	1 5/16	-	-	-	-	-	-
4	-	2 5/16	2 3/16	2 1/16	1 13/16	1 7/8	1 9/16		-	-	-	-	-	-
5•	-	-	-	-	-	-	-	3	2 11/16	2 9/16	2 1/4	1 15/16	1 5/8	

• Furnished with links.

BEAM CLAMPS

Fig. 292: Right-Hand Thread Universal Forged Steel (UFS) Beam Clamp with Weldless Eye Nut

Fig. 292L: Left-Hand Thread

Material: Forged steel

Finish: Plain or Galvanized

Service: For suspension of heavy loads from beams with flange widths to 15" and flange thickness to 1.031.

Approvals: Complies with Federal Specification A-A-1192A (Type 28 without links; Type 29 with links), WW-H-171-E (Type 28 without links; Type 29 with links), ANSI/MSS SP-69 and MSS SP-58 (Type 28 without links; Type 29 with links).

Installation: Fit jaws over edges of lower beam flange and tighten nuts on tie rod to lock clamp in place.

Features:

- Weldless eye nut provides for horizontal pipe movement without binding.
- Weldless eye nut is furnished tapped to any specified rod size up to the maximum rod size.
- Tie rod assures a tight non-slip fit to the beam.
- Self locking nut with a nylon insert prevents the nut from working loose.

Ordering: Specify clamp size, figure number, name, rod size and finish.

Note: The application of a load to a structural beam by means of a beam clamp produces a transverse stress, perpendicular to the axis of the beam, in the flange to which the load is applied.

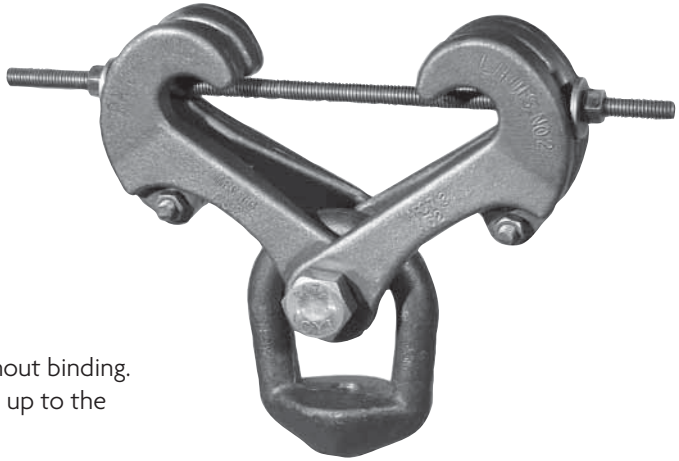

FIG. 292, FIG. 292L: LOADS (LBS) • WEIGHT (LBS) • DIMENSIONS (IN)						
Clamp Size No.	Max Rod Size A	Max Load ■	Weight	Z Max ❖	B	Jaw and Eye Nut Size ▲
1	3/4	3,230	3.9	0.60	1 1/4	292 - 1 / 1
2	1		9.2		1 11/16	292 - 2 / 2
3 •			13.0		1 1/2	292 - 3 / 2
4	21.7					
5 •	1 1/2	5,900	33.9	1.031	2 5/8	292 - 3 / 3
6			23.9			
7 •			35.8			
8	2	11,500	36.8		4 9/16	292 - 3 / 4

▲ For reference only, order by clamp size.

• Furnished with links.

■ Note: Load capacity based on rod sizes shown. For load capacity of other rod sizes see page 233.

❖ For actual "Z" dimensions see table on page 234.

Clamp Size No.	Width of Beam Flange (in)												
	Rod Take Out - E (in)												
	3	4	5	6	7	8	9	10	11	12	13	14	15
1	4 1/2	4 5/16	4 1/16	3 5/8	2 7/8	-	-	-	-	-	-	-	-
2	-	4 3/4	4 7/16	4 1/16	3 3/8	-	-	-	-	-	-	-	-
3 •	-	-	-	-	5 15/16	6	5 5/16	5	-	-	-	-	-
4	-	6 13/16	6 5/8	6 3/8	5 7/8	5 5/8	5 3/8	4 13/16	-	-	-	-	-
5 •	-	-	-	-	-	-	-	-	8 1/8	7 3/4	7 1/8	6 5/8	6 1/16
6	-	7 3/16	7	6 3/4	6 1/4	6 5/16	5 13/16	5 3/16	-	-	-	-	-
7 •	-	-	-	-	-	-	-	-	8 1/2	8 1/8	7 1/2	7	6 7/16
8	-	8 5/8	8 7/16	8 3/16	7 3/4	7 3/4	7 1/4	6 5/8	-	-	-	-	-

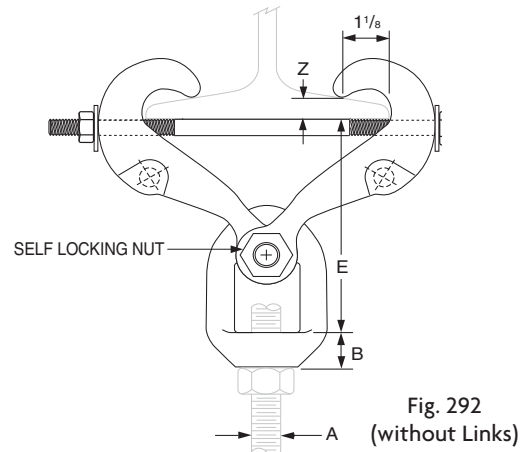

Fig. 292 (without Links)

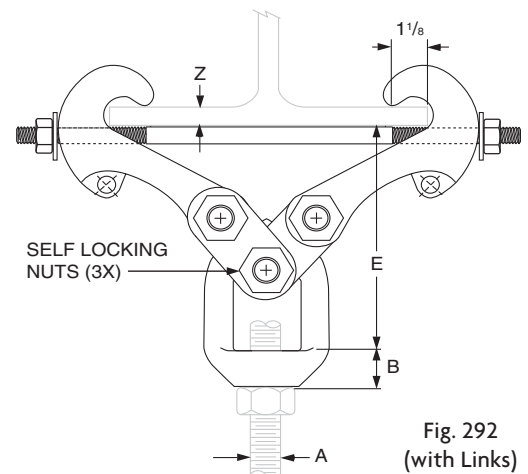

Fig. 292 (with Links)

Fig. 55 (Short) Fig. 55L (Long)

Structural Welding Lug

Size Range: Fig. 55: 1/2" through 3 3/4"
Fig. 55L 1/2" through 2"

Material: Carbon steel

Finish: Plain or Galvanized

Service: For attachment to structural steel in conjunction with the Fig. 299 clevis and with type C variable spring hanger or Type C Constant Support.

Maximum Temperature: Plain 750° F, Galvanized 450° F

Approvals: Complies with Federal Specification A-A-1192A (Type 57), WW-H-171-E (Type 57), ANSI/MSS SP-69 and MSS SP-58 (Type 57).

Ordering: Specify rod size, figure number, name, finish and whether short or long lug is required.

Order Separately: Fig. 291 pin with cotters or bolt and nut

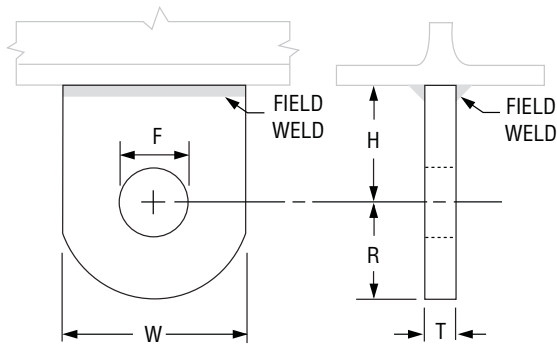
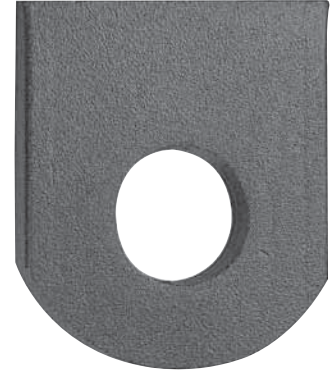

FIG. 55, FIG. 55L: LOAD (LBS) • WEIGHT (LBS) • DIMENSIONS (IN)

Fig. 55, Fig. 55L		Fig. 55 (Short)		Fig. 55L (Long)							
Rod Size A*	Pin or Bolt Dia.	F	R	T	W	Max Load		Rod Take Out - H	Weight	Rod Take Out - H	Weight
						650° F	750° F				
1/2	5/8	1 1/16	1 1/4	1/4	2 1/2	1,350	1,057	1 1/2	0.48	3	0.75
5/8	3/4	1 3/16				2,160	1,692		0.41		0.68
3/4	7/8	1 5/16				3,230	2,530		0.60		1.0
7/8	1	1 1/8				4,480	3,508		0.71		0.98
1	1 1/8	1 1/4	1 1/2	1/2	3	5,900	4,620	2	1.2		1.6
1 1/4	1 3/8	1 1/2	2	5/8	4	9,500	7,440	3	3.0	4	3.7
1 1/2	1 5/8	1 3/4	2 1/2	3/4	5	13,800	10,807		4.8	4 1/2	6.4
1 3/4	1 7/8	2				18,600	14,566		4.7		6.3
2	2 1/4	2 3/8	3	3/4	6	24,600	19,265	4	7.2		8.8
2 1/4	2 1/2	2 5/8				32,300	25,295	7.6	-	-	
2 1/2	2 3/4	2 7/8	4	1	8	39,800	31,169	4 1/2	15.5	-	-
2 3/4	3	3 1/8				49,400	38,687		15.1	-	-
3	3 1/4	3 3/8				60,100	47,066	5	16.0	-	-
3 1/4	3 1/2	3 5/8				71,900	56,307		18.9	-	-
3 1/2	3 3/4	3 7/8	4 1/2	1 1/2	9	84,700	66,331	6	31.3	-	-
3 3/4	4	4 1/8				98,500	77,139		35.9	-	-

* Note: Rod size "A" is the assembly rod diameter. Dimension not shown on drawing

Fig. 54

Two Hole Welding Beam Lug

Size Range: 1/2" through 2 1/4"

Material: Carbon steel

Finish: Plain or Galvanized

Service: For single rod suspension of Fig. 81-H, type B and C constant supports.

Ordering: Specify rod size, figure number, name, finish and "H" dimension.

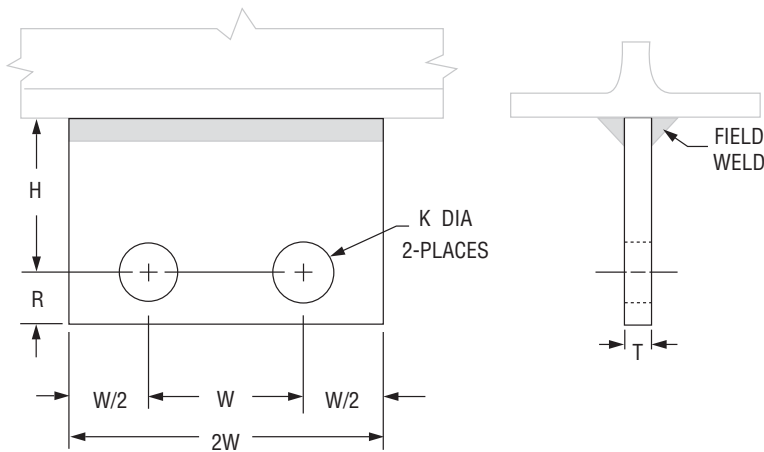
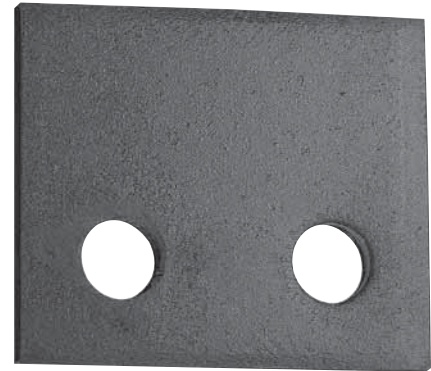

FIG. 54: LOAD (LBS) • WEIGHT (LBS) • DIMENSIONS (IN)

Rod Size A *	Max Load	Weight "H" Dimension ▲				Rod Take Out - "H" Dimension Constant Support Frame Sizes					Pin or Bolt	K Hole	R	T	W	2W	W/2
		1 1/2	2	3	4	1-9	10-18	19-34	35-49	50-63							
1/2	1,350	1.4	1.7	2.2	-	1 1/2	2	3	4	-	5/8	1 1/16	1 1/4	3/8	2 1/2	5	1 1/4
5/8	2,160	1.4	1.6	2.2	-					-	3/4	1 3/16					
3/4	3,230	1.3	1.6	2.1	2.6	-				7/8	1 5/16						
1	5,900	-	2.6	3.5	4.3	-	-	-	1 1/8	1 1/4	1 1/2	1/2	3	6	1 1/2		
1 1/4	9,500	-	5.0	6.5	7.9	-	-	-	1 3/8	1 1/2	2	5/8	4	8	2		
1 1/2	13,800	-	-	10.7	12.8	-	-	-	1 5/8	1 3/4	2 1/2	3/4	5	10	2 1/2		
1 3/4	18,600	-	-	10.4	12.5	-	-	-	1 7/8	2							
2	24,600	-	-	-	16.0	-	-	-	2 1/4	2 3/8							
2 1/4	32,300	-	-	-	15.6	-	-	-	2 1/2	2 5/8	3	6	12	3			

Select "H" dimension applicable to constant support frame size.

▲ Weight varies with "H" dimension.

* Note: Rod size "A" is the assembly rod diameter. Dimension not shown on drawing

Fig: 66

Welded Beam Attachment

Size Range: $\frac{3}{8}$ " through $3\frac{1}{2}$ "

Material: Carbon steel

Finish: Plain or Galvanized

Service: Recommended for attachment to bottom of beams, especially where loads are considerable and rod sizes are large.

Maximum Temperature: Plain 750° F, Galvanized 450° F

Approvals: Complies with Federal Specification A-A-1192A (Type 22), WW-H-171-E (Type 22), ANSI/MSS SP-69 and MSS SP-58 (Type 22).

Installation: If flexibility at the beam is desired, use with bolt and eye rod Fig. 278, page 93, or with weldless eye nut Fig. 290, page 97. If vertical adjustment is desired, use with threaded rod and nut and weld the attachment in an inverted position to the beam.

Features:

- Will accommodate very heavy loads and rod sizes through $3\frac{1}{2}$ ".
- Can be installed so as to provide for either flexibility or for vertical adjustment.
- Versatility affords economical stocking and erection.
- Beam size need not be considered.

Ordering: Specify rod size, figure number, name and finish. Sizes 1" and smaller are typically supplied with a bolt and nut. Sizes $1\frac{1}{4}$ " and larger are typically supplied with a pin and cotters.

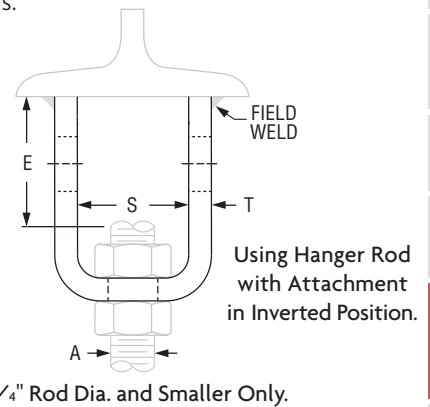
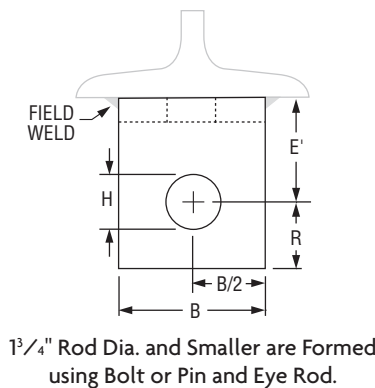
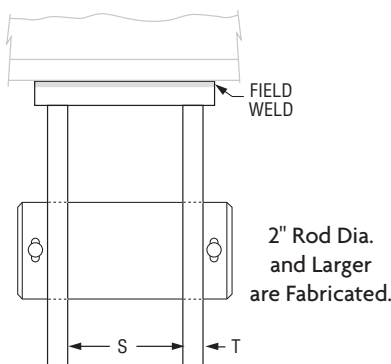
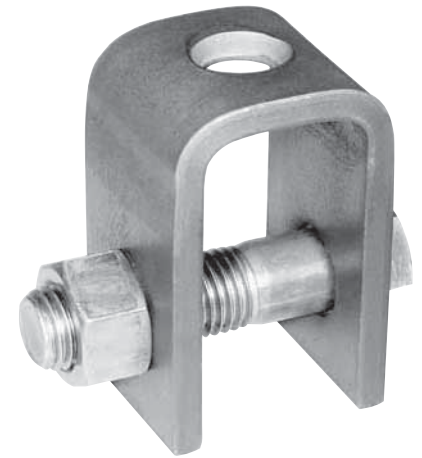

FIG: 66: LOAD (LBS) • WEIGHT (LBS) • DIMENSIONS (IN)

Rod Size A	Pin or Bolt Size	Max Load		Weight		Rod Take Out		B	H	R	S	T
		650° F	750° F	Without Bolt and Nut	With Bolt and Nut	E	E'					
$\frac{3}{8}$	$\frac{1}{2} \times 2\frac{1}{2}$	730	572	0.96	1.2	$1\frac{7}{8}$	2	2	$\frac{9}{16}$	$\frac{7}{8}$	$1\frac{1}{4}$	$\frac{1}{4}$
$\frac{1}{2}$	$\frac{5}{8} \times 2\frac{1}{2}$	1,350	1,057		1.3	$1\frac{3}{4}$			$\frac{11}{16}$			
$\frac{5}{8}$	$\frac{3}{4} \times 2\frac{3}{4}$	2,160	1,692		1.6				$\frac{13}{16}$			
$\frac{3}{4}$	$\frac{7}{8} \times 4$	3,230	2,530	1.9	2.8	$2\frac{5}{8}$	$2\frac{1}{2}$	$\frac{15}{16}$	$1\frac{1}{8}$	$1\frac{7}{8}$	$\frac{3}{8}$	
$\frac{7}{8}$	1×4	4,480	3,508	2.5	3.9			$1\frac{1}{8}$	$1\frac{1}{4}$	2	2	$\frac{1}{2}$
1	$1\frac{1}{8} \times 5$	5,900	4,620	4.3	6.3	$2\frac{3}{4}$	3	3	$1\frac{1}{4}$	$1\frac{1}{2}$	$2\frac{1}{2}$	$\frac{1}{2}$
$1\frac{1}{4}$	$1\frac{3}{8} \times 5\frac{3}{8}$	9,500	7,440	8.1	10.2	$2\frac{7}{8}$	4	5	$1\frac{1}{2}$	2	$2\frac{1}{2}$	$\frac{5}{8}$
$1\frac{1}{2}$	$1\frac{5}{8} \times 6$	13,800	10,807	–	19.0	–			4	5	$1\frac{3}{4}$	$2\frac{1}{2}$
$1\frac{3}{4}$	$1\frac{7}{8} \times 6\frac{7}{8}$	18,600	14,566	–	24.2	–	5	6	2	$2\frac{3}{4}$	$3\frac{3}{4}$	$\frac{1}{2}$
2	$2\frac{1}{4} \times 6\frac{7}{8}$	24,600	19,265	–	30.6	–			5	6	$2\frac{3}{8}$	$3\frac{1}{4}$
$2\frac{1}{4}$	$2\frac{1}{2} \times 7\frac{3}{8}$	32,300	25,295	–	36.8	–	6	7	$2\frac{1}{2}$	$3\frac{1}{2}$	$3\frac{1}{2}$	$\frac{5}{8}$
$2\frac{1}{2}$	$2\frac{3}{4} \times 7\frac{3}{8}$	39,800	31,169	–	39.7	–			6	7	$2\frac{7}{8}$	
$2\frac{3}{4}$	3×7	49,400	38,687	–	40.8	–	7	8	$3\frac{1}{8}$	4	$3\frac{3}{4}$	$\frac{5}{8}$
3	$3\frac{3}{4} \times 7$	60,100	47,066	–	46.7	–			7			
$3\frac{1}{4}$	$3\frac{1}{2} \times 7\frac{3}{4}$	71,900	56,307	–	62.1	–	8	8	$3\frac{5}{8}$	$4\frac{1}{2}$	$4\frac{1}{4}$	$\frac{3}{4}$
$3\frac{1}{2}$	$3\frac{3}{4} \times 7\frac{3}{4}$	84,700	66,331	–	72.4	–			8			

Fig. 60

Steel Washer Plate

Size Range: $\frac{3}{8}$ " to $3\frac{3}{4}$ "

Material: Carbon steel

Finish: Plain or Galvanized

Service: A heavy duty washer plate used on top of channels or angles for supporting pipe with rods or U-bolts.

Maximum Temperature: Plain 750° F, Galvanized 450° F

Ordering: Specify rod size, figure number, name and finish.

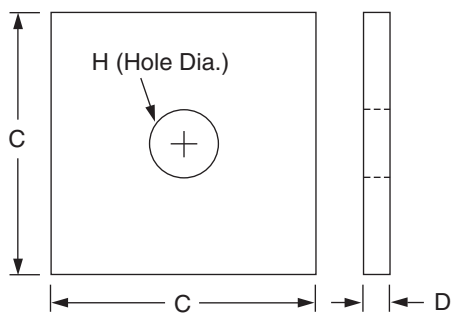
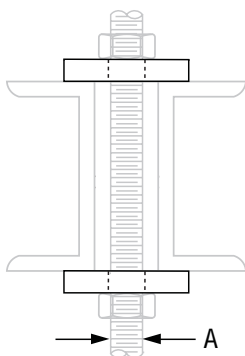
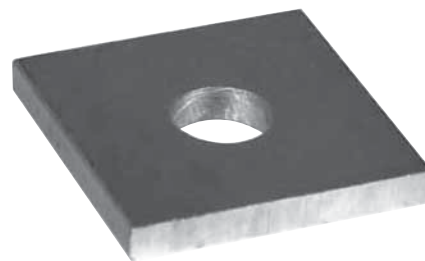

FIG. 60: WEIGHT (LBS) • DIMENSIONS (IN)

Rod Size A	Weight	Max Load		C x C x D Size of Stock	Hole Dia. H
		650° F	750° F		
$\frac{3}{8}$	0.6	730	572	3 x 3 x $\frac{1}{4}$	$\frac{1}{2}$
$\frac{1}{2}$	0.6	1,350	1,057		$\frac{5}{8}$
$\frac{5}{8}$	0.9	2,160	1,692	3 x 3 x $\frac{3}{8}$	$\frac{3}{4}$
$\frac{3}{4}$	1.6	3,230	2,530	4 x 4 x $\frac{3}{8}$	$\frac{7}{8}$
$\frac{7}{8}$	2.2	4,480	3,508	4 x 4 x $\frac{1}{2}$	1
1	2.1	5,900	4,620		$1\frac{1}{4}$
$1\frac{1}{4}$	3.3	9,500	7,440	5 x 5 x $\frac{1}{2}$	$1\frac{1}{2}$
$1\frac{1}{2}$	4.8	13,800	10,807	5 x 5 x $\frac{3}{4}$	$1\frac{3}{4}$
$1\frac{3}{4}$	4.7	18,600	14,566		2
2	4.5	24,600	19,265		$2\frac{1}{4}$
$2\frac{1}{4}$	6.6	32,300	25,295	6 x 6 x $\frac{3}{4}$	$2\frac{1}{2}$
$2\frac{1}{2}$	6.4	39,800	31,169		$2\frac{3}{4}$
$2\frac{3}{4}$	6.2	49,400	38,687		3
3	5.9	60,100	47,066		$3\frac{1}{4}$
$3\frac{1}{4}$	5.6	71,900	56,307	7 x 7 x $\frac{3}{4}$	$3\frac{1}{2}$
$3\frac{1}{2}$	8.1	84,700	66,331		$3\frac{3}{4}$
$3\frac{3}{4}$	7.8	98,500	77,139		4

Fig. 112 Fig. 113

Brace Fitting Complete Pipe End Only

Size Range: 1" and 1 1/4"

Material: Malleable iron bracket and pipe end; hex cap screw and nut.

Finish: Plain

Service: For bracing piping against sway and seismic movement.

Installation: Normally two fittings are used; a Fig. 112 complete attached to one end of an IPS nipple and a Fig. 113 pipe end only attached to the other end.

The brace fitting completely connects to the building structure while the pipe end only connects to the pipe attachment. Use with Fig. 212 FP pipe clamp see page 46.

Features:

- Two piece pivoted assembly accommodates any angle to structure.
- Sight hole in pipe end provides easy means of verifying proper thread engagement.

Ordering: Specify size, figure number, name.

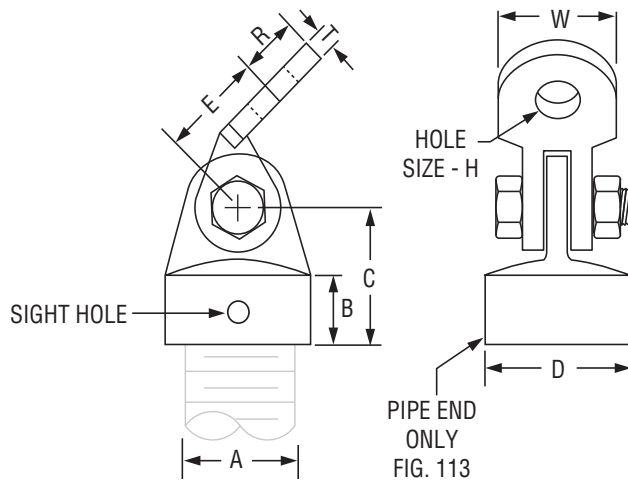

FIG. 112, FIG. 113: LOAD (LBS) • WEIGHT (LBS) • DIMENSIONS (IN)											
Pipe Size A	Max Load ■	Weight		B	C	D	E	Hole Dia. H	R	T	W
		Fig. 112	Fig. 113								
1	850	0.95	0.50	1	2 ³ / ₁₆	1 ¹ / ₁₆	1 ¹ / ₂	9/ ₁₆	3/ ₄	1/ ₄	1 ¹ / ₂
1 1/4	1,150	1.40	0.80			2 ³ / ₁₆		3/ ₄	7/ ₈	5/ ₁₆	1 1/4

■ Based on MSS-SP 127 at 450° F and maximum nipple length of 6 feet.

- Pictorial Table of Contents
- General Notes
- Copper Tubing Hangers
- CPVC Pipe Hangers
- Pipe Rings
- Clevis Hangers
- Steel Pipe Clamps
- Socket Clamps
- Beam Clamps
- Structural Attachments**
- Brackets
- Ceiling Plates & Flanges
- Concrete Inserts & Attachments
- Hanger Rods
- Rod Attachments
- Bolts, Nuts, Pins & U-Bolts

Fig. 202

Iron Side Beam Bracket

Size Range: $\frac{3}{8}$ " through $\frac{5}{8}$ "

Material: Malleable iron

Finish: Plain or Galvanized

Service: Recommended for attachment to steel or wooden beams, etc.

Approvals: Complies with Federal Specification A-A-1192A (Type 34) WW-H-171-E (Type 35), ANSI/MSS SP-69 and MSS SP-58 (Type 34).

UL, ULC Listed and FM Approved (Sizes $\frac{3}{8}$ " for use on wooden and steel beams and $\frac{1}{2}$ " for use on steel beams).

Features: An economical, practical and adjustable means of securing hangers to beams, etc.

Ordering: Specify rod size, figure number, name and finish.

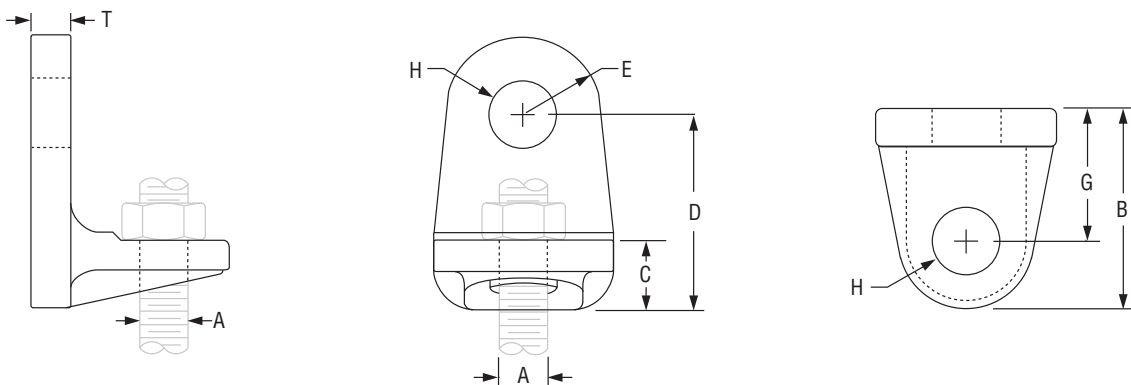

FIG. 202: LOAD (LBS) • WEIGHT (LBS) • DIMENSIONS (IN)

Rod Size A	Max Load ■		Weight	B	C	D	E	Hole Dia. H	G	T
	With Lag Screw	With Bolt to Steel								
$\frac{3}{8}$	390	730	0.26	$1\frac{1}{8}$	$\frac{5}{8}$	$1\frac{1}{16}$	$\frac{17}{32}$	$\frac{7}{16}$	$\frac{7}{8}$	$\frac{1}{4}$
$\frac{1}{2}$	640	1,350	0.54	$1\frac{13}{16}$	$\frac{3}{4}$	$1\frac{1}{8}$	$2\frac{1}{32}$	$\frac{9}{16}$	$1\frac{3}{16}$	$1\frac{11}{32}$
$\frac{5}{8}$	760	2,160	0.94	$2\frac{3}{16}$	$\frac{7}{8}$	$2\frac{1}{8}$	$\frac{7}{8}$	$\frac{3}{4}$	$1\frac{1}{16}$	$\frac{7}{16}$

■ Maximum temperature of 450° F.

Fig. 206

Steel Side Beam Bracket

Size Range: $\frac{3}{8}$ " through $\frac{5}{8}$ "

Material: Carbon steel

Finish: Plain or Galvanized

Service: Clip can be fastened to side of joist or wall to support hanger rod.

Approvals: Complies with Federal Specification A-A-1192A (Type 34), WW-H-171-E (Type 35) and ANSI/MSS SP-69 and MSS SP-58 (Type 34). UL Listed and FM Approved (steel beam only).

Ordering: Specify rod size, figure number, name and finish.

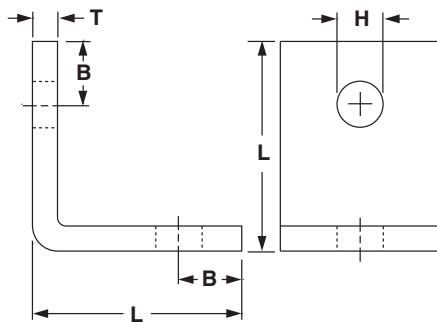

FIG. 206: LOAD (LBS) • WEIGHT (LBS) • DIMENSIONS (IN)

Rod Size A	Max Load		Weight (lbs).	L	B	Hole Size H	T
	With Lag Screw	With Bolt to Steel					
$\frac{3}{8}$	650	1,150	0.44	$2\frac{1}{16}$	$\frac{5}{8}$	$\frac{7}{16}$	$\frac{1}{4}$
$\frac{1}{2}$			0.43			$\frac{9}{16}$	
$\frac{5}{8}$	850	2,000	0.84	$2\frac{1}{2}$	$\frac{3}{4}$	$1\frac{1}{16}$	$\frac{3}{8}$

Fig. 207

Threaded Steel Side Beam Bracket

Size Range: $\frac{3}{8}$ " and $\frac{1}{2}$ "

Material: Carbon steel

Finish: Plain or Galvanized

Service: Recommended for attachment to steel or wooden beams, etc.

Approvals: Complies with Federal Specification A-A-1192A (Type 34), WW-H-171-E (Type 35), ANSI/MSS SP-69 and MSS SP-58 (Type 34). UL Listed (Sizes $\frac{3}{8}$ " and $\frac{1}{2}$ ").

FM Approved (Size $\frac{3}{8}$ " for use on steel beam only)

Features: Threaded mounting bracket provides an economical, practical and adjustable means of securing hangers to beams.

Ordering: Specify rod size, figure number, name and finish.

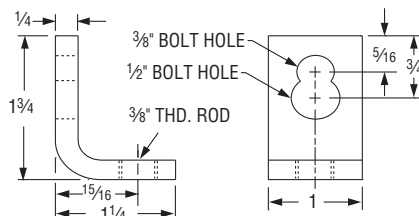

Fig. 207 $\frac{3}{8}$ "

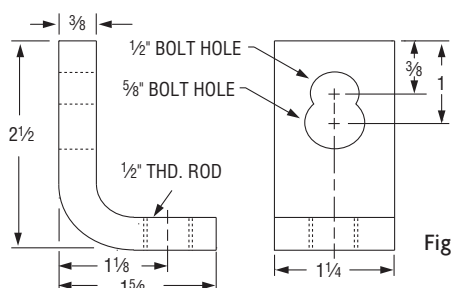

Fig. 207 $\frac{1}{2}$ "

FIG. 207: LOAD (LBS) • WEIGHT (LBS) • DIMENSIONS (IN)

Rod Size A	Bolt Size	Max Load		Weight
		With Lag Screw	With Bolt to Steel	
$\frac{3}{8}$	$\frac{3}{8}$	400	620	0.17
	$\frac{1}{2}$	560		
$\frac{1}{2}$	$\frac{1}{2}$	650	1,150	0.42
	$\frac{5}{8}$	850		

- Pictorial Table of Contents
- General Notes
- Copper Tubing Hangers
- CPVC Pipe Hangers
- Pipe Rings
- Clevis Hangers
- Steel Pipe Clamps
- Socket Clamps
- Beam Clamps
- Structural Attachments
- Brackets**
- Ceiling Plates & Flanges
- Concrete Inserts & Attachments
- Hanger Rods
- Rod Attachments
- Bolts, Nuts, Pins & U-Bolts

Fig. 189

Straight Eye Socket

Size: 3/8"

Material: Galvanized steel

Service: Attachment to structure to connect threaded hanger rod.

Approvals: UL and ULC Listed, and FM Approved.

Installation:

- Thread rod completely into hanger. Secure rod by tightening jam nut against bottom of hanger.
- Secure hanger to structural member with recommended fasteners.

Features:

- Pre-formed threads for easy rod assembly.

Ordering: Specify rod size, figure number and name.



Description	Pipe Sizes	Rod Size	Max. Load
Straight Eye Socket Hanger	3/4" - 4"	3/8-16 UNC	250 lbs.

FASTENERS		
Description	Quantity	Pipe Size
#14 x 2" Wood Screw	2	*3/4" - 2"
1/2" x 3" Lag Screw	*1	3/4" - 4"
3/8-16 UNC Jam Nut	1	3/4" - 4"

* Lag screw not required for 3/4" - 2" pipe sizes using the alternate option of (2) wood screws.

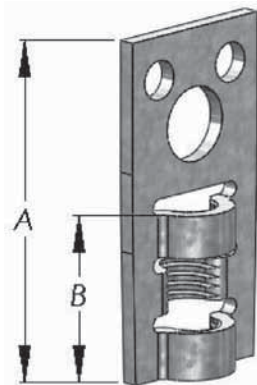
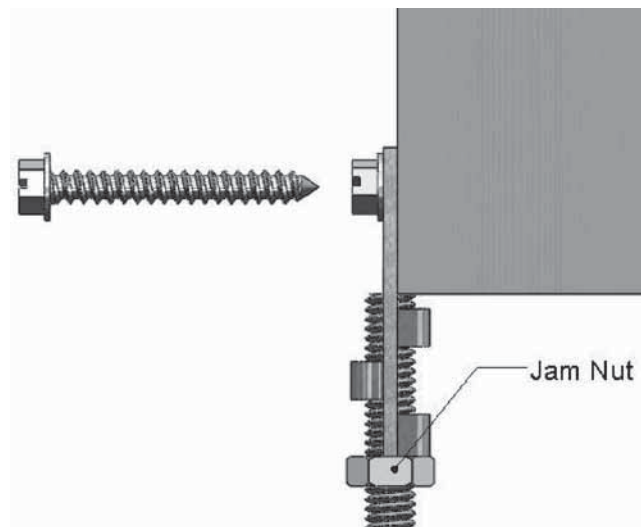

FIG. 189: DIMENSIONS (IN)	
A	B
2.28	1.10



Notes:

1. For fire protection installation follow the requirements of National Fire Protection Association, NFPA-13 and local codes.
2. To assure proper performance, installer is responsible for:
 - a. Structural integrity of attachment member to safely handle load requirements.
 - b. Securely tightening jam nut on the hanger rod.

Fig. 190

Off-Set Eye Socket

Size: 3/8"

Material: Galvanized steel

Service: Attachment to structure to connect threaded hanger rod.

Approvals: UL and ULC Listed, and FM Approved.

Installation:

- Thread rod completely into hanger. Secure rod by tightening jam nut against bottom of hanger.
- Secure hanger to structural member with recommended fasteners.

Features:

- Pre-formed threads for easy rod assembly.
- Off-set angle provides unlimited vertical adjustment.

Ordering: Specify rod size, figure number and name.

Description	Pipe Sizes	Rod Size	Max. Load
Off-Set Eye Socket Hanger	3/4" - 4"	3/8-16 UNC	250 lbs.

FASTENERS		
Description	Quantity	Pipe Size
#14 x 2" Wood Screw	2	*3/4" - 2"
1/2" x 3" Lag Screw	*1	3/4" - 4"
3/8-16 UNC Jam Nut	1	3/4" - 4"

* Lag screw not required for 3/4" - 2" pipe sizes using the alternate option of (2) wood screws.

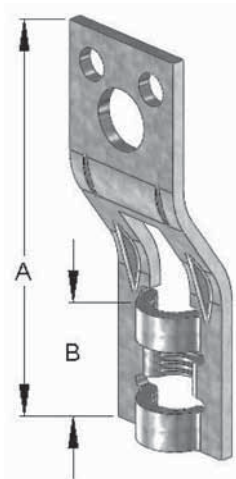
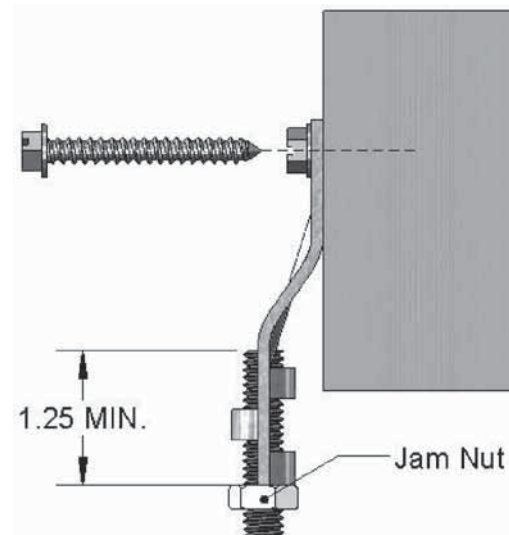

FIG. 190: DIMENSIONS (IN)	
A	B
3.38	1.10



Notes:

1. For fire protection installation follow the requirements of National Fire Protection Association, NFPA-13 and local codes.
2. To assure proper performance, installer is responsible for:
 - a. Structural integrity of attachment member to safely handle load requirements.
 - b. Securely tightening jam nut on the hanger rod.

Fig. 194

Light Welded Steel Bracket

Material: Carbon steel

Finish: Plain or Galvanized

Service: Recommended for support from below or above bracket.

Approvals: Complies with Federal Specification A-A-1192A (Type 31), WW-H-171-E (Type 32), ANSI/MSS SP-69 and MSS SP-58 (Type 31).

FM Approved when used with $\frac{3}{8}$ " rod, $\frac{3}{4}$ " - 4" pipe sizes & $\frac{1}{2}$ " rod, 5" - 8" pipe sizes.

How to size: Determine bracket size by dimension of standard bracket most suitable to the installation.

Installation: When bolted to a wall, an additional back plate may be required of such thickness and size as to properly distribute the weight over the wall. Size and thickness of the back plate is governed by the load to be carried and the nature and conditions of the wall. Back plates furnished upon request.

Features:

- Bracket may be installed either in position illustrated or reversed.
- Ends of bracket are drilled to accept hanger rods up to $\frac{3}{4}$ ".

Ordering: Specify bracket number, figure number, name and finish.

Order separately: Hanger rods, 2 bolts and plate washers are available through our Regional Service Centers, order as a Figure 193.

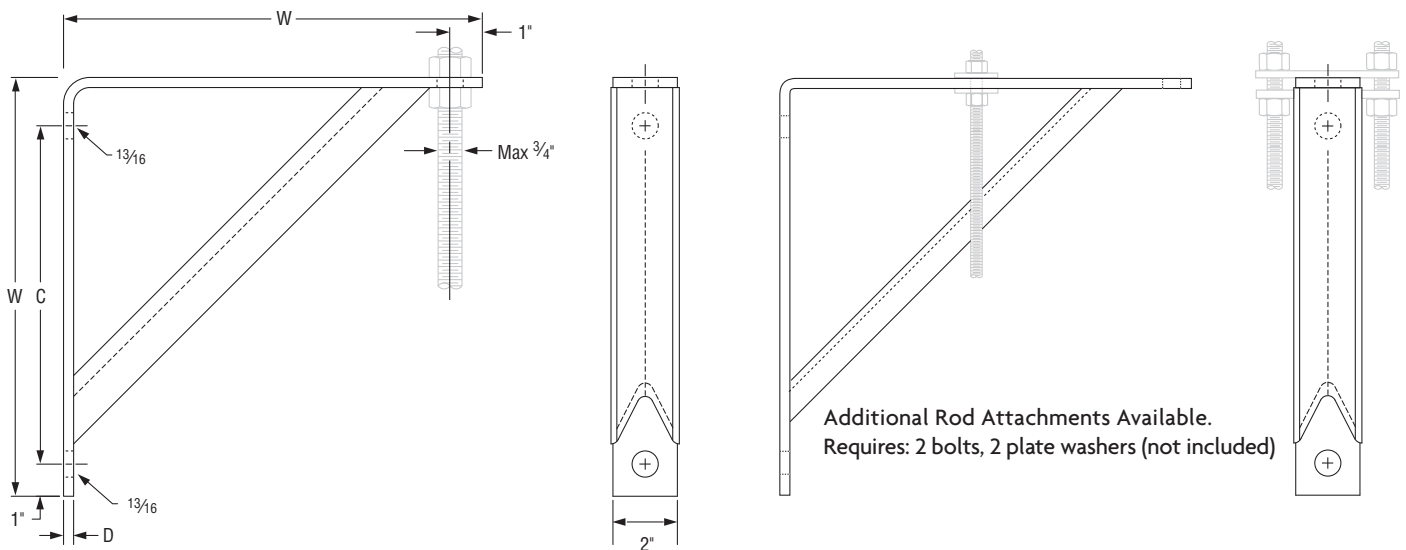
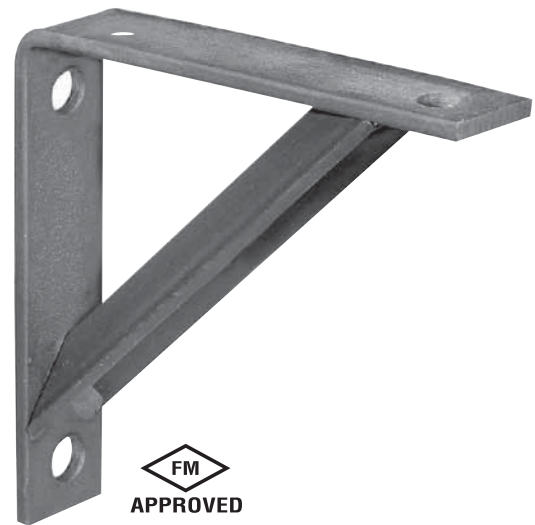

FIG. 194: LOAD (LBS) • WEIGHT (LBS) • DIMENSIONS (IN)					
Bracket no.	Max Load	Weight	W	C	D
1	750	3.1	9	6½	5/16
2		7.7	13	10½	
3		12.8	19	16½	3/8

Fig. 195

Medium Welded Steel Bracket

Material: Carbon steel

Finish: Plain or Galvanized

Service: Recommended for the support of loads from below or above bracket.

Approvals: Complies with Federal Specification A-A-1192A (Type 32), WW-H-171-E (Type 33), ANSI/MSS SP-69 and MSS SP-58 (Type 32).

How to size: Determine size by dimensions most suitable to the installation (see dimensions of standard brackets below). Special welded steel brackets can be furnished on order.

Installation: When bolted to a wall, an additional back plate may be required of such thickness and size as to properly distribute the weight over the wall. Size and thickness of the back plate is governed by the load to be carried and the nature and conditions of the wall. Back plates furnished upon request.

Features: If supporting pipe by rod, rod can be installed anywhere along the length of the bracket thus providing horizontal adjustment.

Ordering: Specify bracket number, figure number, name and finish. Orders for special brackets are to be accompanied by detailed sketch.

Order Separately: Rod, Fig. 60, bolts, nuts, and back plates for fastening brackets to wall. Specify size and length of rod, bolts size, thickness, and drilling of back plates.

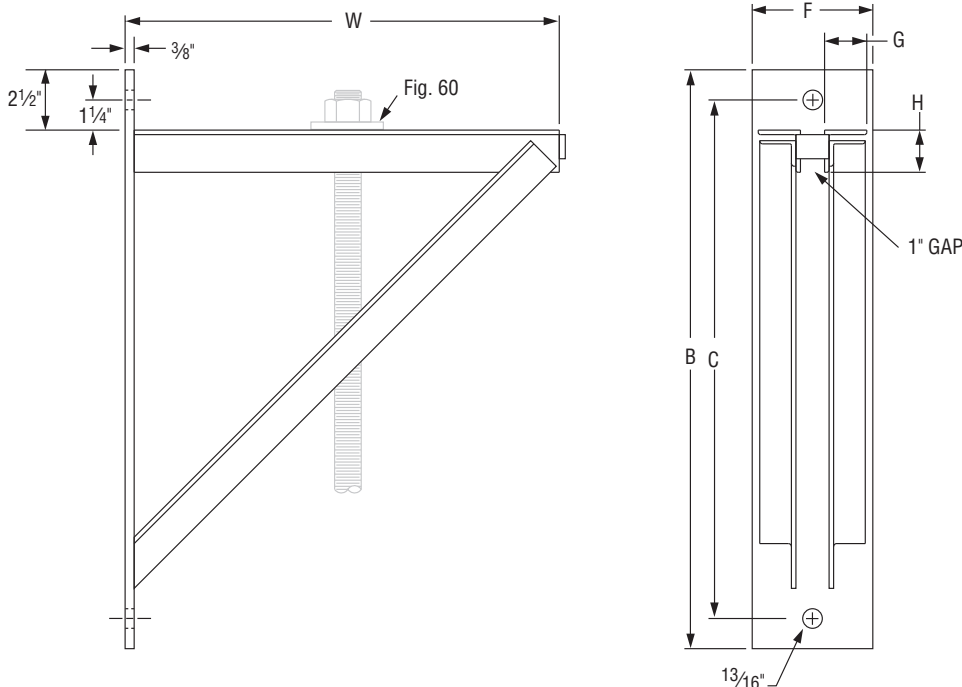

FIG. 195: LOAD (LBS) • WEIGHT (LBS) • DIMENSIONS (IN)

Bracket no.	Max Load	Weight	W	B	C	F	G	H
0	1,500	17.4	12	18	15½	4	1½	1½
1		27.3	18	24	21½	5	1¾	1¾
2		47.7	24	30	27½		2	2

BRACKETS

Fig. 199

Heavy Welded Steel Bracket

Material: Carbon steel

Finish: Plain or Galvanized

Service: Recommended for the support of loads from above or below bracket.

Approvals: Complies with Federal Specification A-A-1192A (Type 33)

WW-H-171-E (Type 34), ANSI/MSS SP-69 and MSS SP-58 (Type 33).

How to size: Determine size by dimensions most suitable to the installation (see dimensions of standard brackets below). Special welded steel brackets can be furnished on order.

Installation: When bolted to a wall, an additional back plate may be required of such thickness and size as to properly distribute the weight over the wall. Size and thickness of the back plate is governed by the load to be carried and the nature and conditions of the wall. Back plates furnished upon request.

Features: If supporting pipe by rod, rod can be installed at any point along the length of the bracket thus providing horizontal adjustment.

Ordering: Specify bracket number, figure number, name. Orders for special brackets are to be accompanied by detailed sketch.

Order Separately: Rod, Fig. 60, bolts, nuts, and back plates for fastening brackets to wall. Specify size and length of rod, bolts size, thickness, and drilling of back plates.

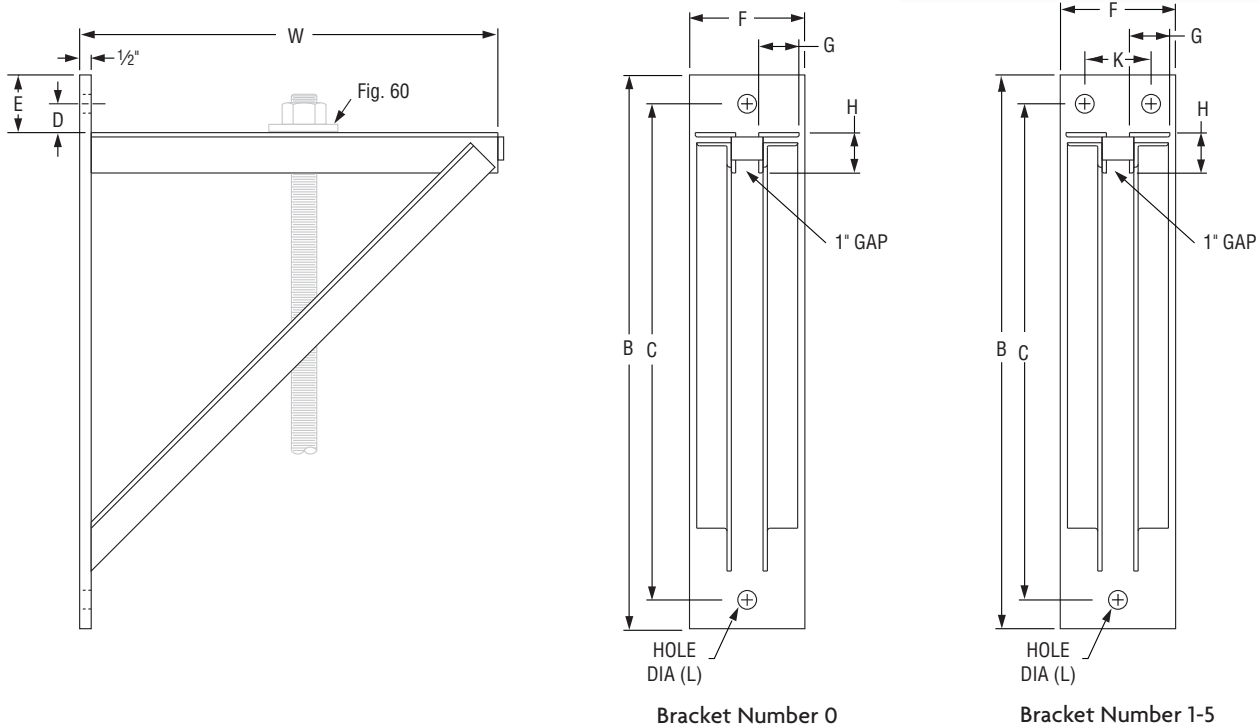

FIG. 199: LOAD (LBS) • WEIGHT (LBS) • DIMENSIONS (IN)

Bracket no.	Max Load	Weight	W	B	C	D	E	F	G	H	K	L
0	3,000	24.3	12	18	15 ³ / ₄	1 ³ / ₈	2 ³ / ₄	4	1 ¹ / ₄	2	—	1 ³ / ₁₆
1		51.8	18	24	21 ³ / ₈	1 ⁷ / ₁₆		5	2		2 ³ / ₄	1 ⁵ / ₁₆
2		68.9	24	30	27 ¹ / ₂	1 ¹ / ₂	3	6	2 ¹ / ₂	3 ¹ / ₂	2 ¹ / ₂	1 ¹ / ₁₆
3		86.1	30	36	33 ³ / ₄	1 ⁵ / ₈						
4		140.5	36	42	39	1 ¹ / ₂						
5		166.4	42	50	46		3 ¹ / ₂					

Fig. 127

Plastic Ceiling Plate

Size Range: $\frac{3}{8}$ " and $\frac{1}{2}$ "

Material: Plastic

Service: Recommended for giving a finished appearance where rod enters ceiling.

Installation: Slide plate up rod until flush against ceiling.

Features:

- Highly economical
- Quickly installed
- Held firmly to rod by design and friction

Ordering: Specify rod size, figure number, name. (rod not included)



FIG. 127: WEIGHT (LBS) • DIMENSIONS (IN)			
Rod Size A	Weight	Outside Dia.	Depth
$\frac{3}{8}$	0.07	$1\frac{13}{16}$	$\frac{1}{2}$
$\frac{1}{2}$			

Fig. 395

Cast Iron Ceiling Plate

Size Range: $\frac{1}{2}$ " through 8"

Material: Cast iron

Finish: Plain or Galvanized

Service: Gives finished appearance where pipe enters ceiling.

Installation: Sizes $\frac{1}{2}$ " to 4" furnished with one machine screw; sizes 5" to 8", two machine screws.

Ordering: Specify pipe size, figure number, name and finish.

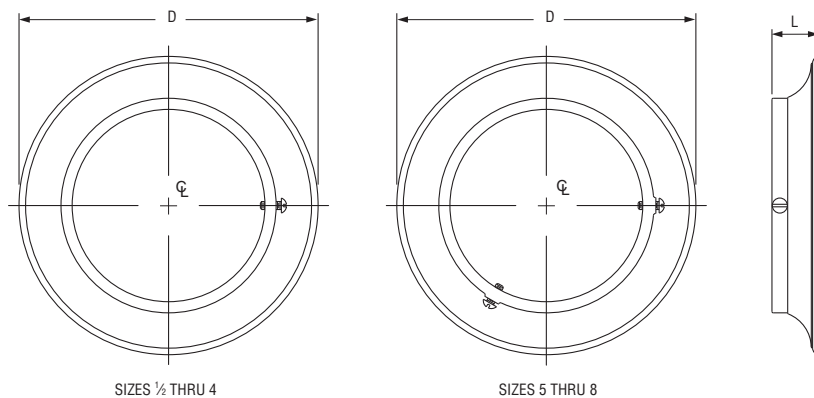

FIG. 395: WEIGHT (LBS) • DIMENSIONS (IN)			
Pipe Size	Weight	D - Dia.	L
$\frac{1}{2}$	0.21	$2\frac{7}{8}$	$\frac{3}{4}$
$\frac{3}{4}$	0.40	$3\frac{3}{8}$	1
1	0.41	$3\frac{5}{8}$	
$1\frac{1}{4}$	0.51	4	
$1\frac{1}{2}$	0.55	$4\frac{1}{4}$	
2	0.67	$4\frac{3}{4}$	
$2\frac{1}{2}$	0.93	$5\frac{1}{2}$	$6\frac{1}{8}$
3	1.10	$6\frac{1}{8}$	
$3\frac{1}{2}$	1.20	$6\frac{5}{8}$	
4	1.40	$7\frac{1}{8}$	$1\frac{1}{4}$
5	2.50	$8\frac{11}{16}$	
6	3.10	$9\frac{1}{4}$	
8	3.30	$11\frac{3}{4}$	

Fig. 128R

Rod Threaded, Ceiling Flange

Size Range: $\frac{3}{8}$ " and $\frac{1}{2}$ "

Material: Malleable iron

Finish: Plain or Galvanized

Service: Recommended for attachment to wood beams or ceiling.

Ordering: Specify rod size, figure number, name and finish.

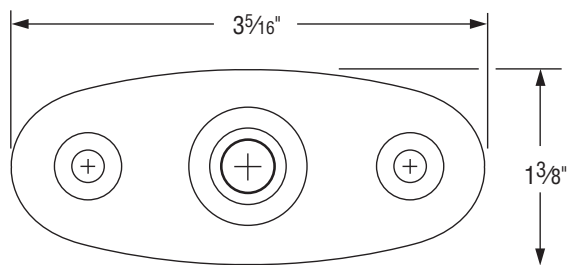
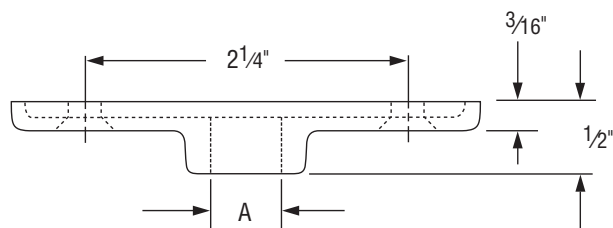

FIG. 128R: LOAD (LBS) • WEIGHT (LBS) • DIMENSIONS (IN)				
Rod Size A	Max Load	Weight	Screws (not included)	
			Quantity	Size No.
$\frac{3}{8}$	180	0.16	2	12
$\frac{1}{2}$				

Fig. 153

Pipe Hanger Flange

Size Range: $\frac{3}{8}$ " through $\frac{3}{4}$ "

Material: Malleable iron

Finish: Plain

Service: Recommended for suspension of pipe lines or conduit from level ceilings.

Approvals: UL, ULC Listed and FM Approved (Sizes $\frac{3}{8}$ " and $\frac{1}{2}$ ").

Installation: Flange size $\frac{3}{8}$ " has two holes, sizes $\frac{1}{2}$ ", $\frac{5}{8}$ ", and $\frac{3}{4}$ " have three holes.

Features:

- Provides vertical adjustment up to 1".
- Good appearance.

Ordering: Specify rod size, figure number and name.

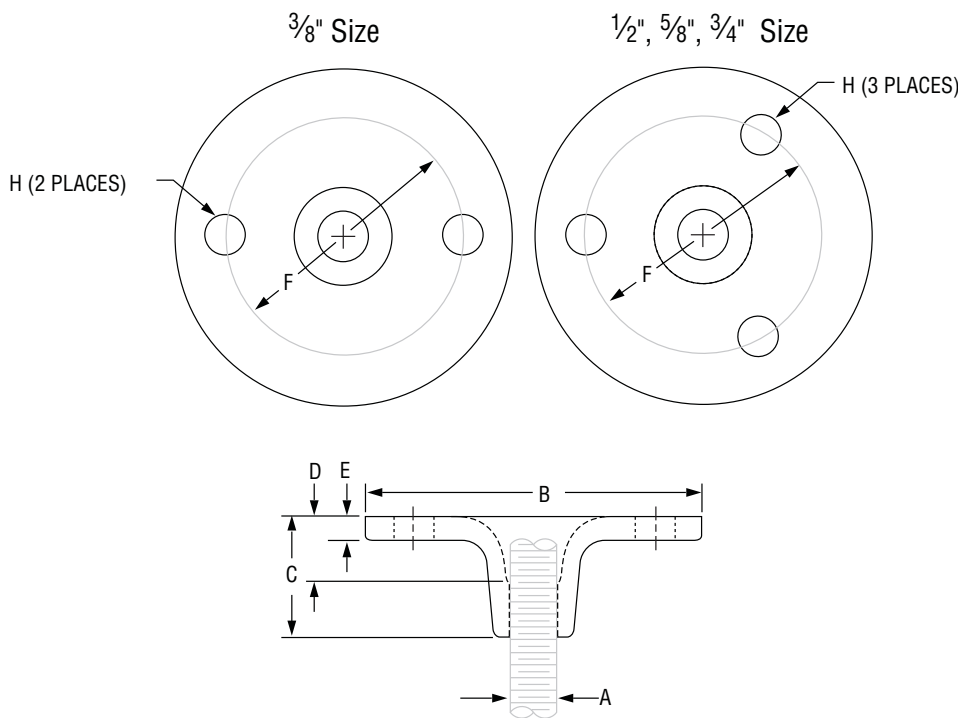

FIG. 153: LOAD (LBS) • WEIGHT (LBS) • DIMENSIONS (IN)

Rod Size A	Max Load	Weight	Size Screw "H" (not included)	B	C	D	E	Screw Circle Dia. - F
$\frac{3}{8}$	425	0.4	#18 x $1\frac{1}{2}$	$2\frac{7}{8}$	$1\frac{3}{8}$	$\frac{7}{8}$	$\frac{3}{16}$	2
$\frac{1}{2}$	1,050	0.9	$\frac{3}{8}$ x 2	4	$1\frac{1}{2}$	$\frac{15}{16}$	$\frac{1}{4}$	$2\frac{7}{8}$
$\frac{5}{8}$	1,220	1.5	$\frac{1}{2}$ x 2	$4\frac{3}{4}$	$1\frac{5}{8}$	1	$\frac{5}{16}$	$3\frac{3}{8}$
$\frac{3}{4}$	1,270	2.2	$\frac{9}{16}$ x 2	$5\frac{1}{4}$	$1\frac{7}{8}$	$1\frac{1}{16}$	$\frac{3}{8}$	$3\frac{5}{8}$

Fig. 152

Screw Concrete Insert

Size Range: $\frac{3}{8}$ " through $\frac{7}{8}$ "

Material: Malleable iron

Finish: Plain

Service: Upper attachment for suspending pipe from a concrete ceiling where no lateral adjustment is required.

Approvals: UL, ULC Listed and FM Approved.

Features:

- Eliminates the necessity of drilling holes in wooden forms.
- Reduced overall height and four slots for nail attachment gives stability to the insert while the concrete is being poured.

Ordering: Specify rod size, figure number and name.

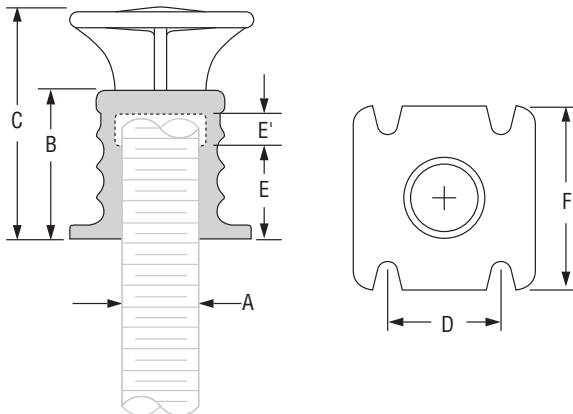

FIG. 152: LOAD (LBS) • WEIGHT (LBS) • DIMENSIONS (IN)

Rod Size A	Max Load ■	Weight	B	C	D	E	E'	F
$\frac{3}{8}$	730	0.31	$1\frac{1}{32}$	$2\frac{1}{4}$	1	$\frac{1}{2}$	$\frac{3}{8}$	$1\frac{1}{8}$
$\frac{1}{2}$	1,130	0.32				$\frac{5}{8}$		
$\frac{5}{8}$	1,260	0.37	$1\frac{7}{32}$	$2\frac{1}{2}$	$1\frac{1}{4}$	$\frac{15}{16}$	$\frac{7}{16}$	2
$\frac{3}{4}$	2,500	0.64	$1\frac{5}{8}$			1	$\frac{3}{8}$	
$\frac{7}{8}$		0.71						

■ Based on insert only. Rating is subject to the condition that the concrete used is of sufficient strength to hold the insert.

Fig. 282

Universal Concrete Insert

Size Range: $\frac{3}{8}$ " through $\frac{7}{8}$ "

Material: Malleable iron body and nut

Finish: Plain or Galvanized

Service: Upper attachment for suspending pipe, shafting, motors and similar equipment from a concrete ceiling; especially suitable where rod sizes cannot be readily determined in advance.

Approvals: Complies with Federal Specification A-A-1192A (Type 18), WW-H-171-E (Type 18), ANSI/MSS SP-69 and MSS SP-58 (Type 18). UL, ULC Listed and FM Approved.

Installation:

1. Nail insert to wooden forms.
2. Where convenient, reinforcing rods may be placed in the opening through the top of the insert, or short lengths of reinforcing rod may be wired to the insert prior to pouring concrete. However, the specified load ratings and approvals are not dependent on the use of any reinforcing rods in contact with the insert.
3. After concrete is poured and wooden forms are removed, place nut in insert and screw rod through nut until rod is firmly against the top of the insert body. The rod should not be forced against the top of the recess thereby placing unnecessary stress at the opening of the insert by the nut.

Features:

- Cast body prevents concrete seepage.
- Opening in top of insert provides for use of reinforcing rods up to $\frac{7}{8}$ " diameter. Sides of insert are recessed for reinforcing rods up to 1" diameter.
- Low height, broad flat bottom and widely separated nail slots minimize displacement during construction.
- The nut, held in place by V-type teeth on both insert and nut, can be raised and moved from side to side providing for lateral adjustment.
- Rod is locked in place by screwing it firmly against the top of the recess.
- One body size.

Ordering: Specify figure number, name, finish and size of nut.

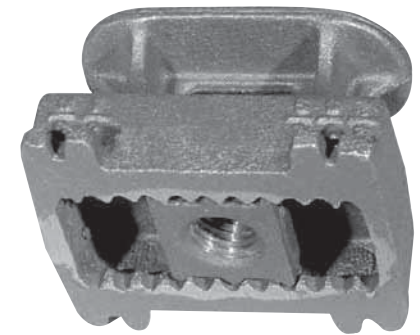

- Pictorial Table of Contents
- General Notes
- Copper Tubing Hangers
- CPVC Pipe Hangers
- Pipe Rings
- Clevis Hangers
- Steel Pipe Clamps
- Socket Clamps
- Beam Clamps
- Structural Attachments
- Brackets
- Ceiling Plates & Flanges
- Concrete Inserts & Attachments
- Hanger Rods
- Rod Attachments
- Bolts, Nuts, Pins & U-Bolts

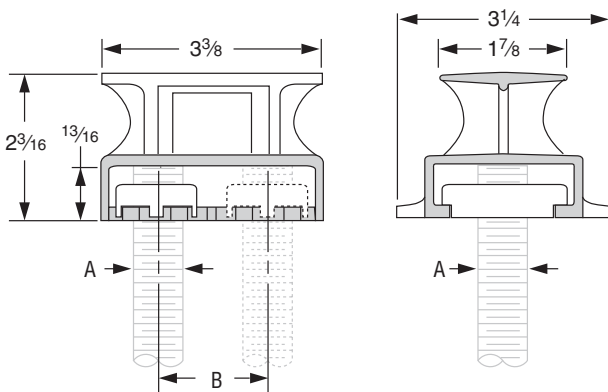

FIG. 282: LOAD (LBS) • WEIGHT (LBS) • DIMENSIONS (IN)				
	Rod Size A	Adjustment B	Max Load ■	Weight
Insert Complete With Nut	$\frac{3}{8}$	$1\frac{1}{16}$	730	1.5
	$\frac{1}{2}$		1,130	
	$\frac{5}{8}$		1,140	
	$\frac{3}{4}$		1,140	
	$\frac{7}{8}$	$1\frac{1}{8}$	1,140	
Insert Only	—	—	—	1.3
Nut Only	$\frac{3}{8}$	—	—	0.2
	$\frac{1}{2}$	—	—	
	$\frac{5}{8}$	—	—	
	$\frac{3}{4}$	—	—	
	$\frac{7}{8}$	—	—	

■ Based on insert and nut only. Rating is subject to the condition that the concrete used is of sufficient strength to hold the insert.

Fig. 281

Wedge Type Concrete Insert

Size Range: $\frac{3}{8}$ " through $\frac{7}{8}$ "

Material: Carbon steel body; malleable iron nut

Finish: Plain or Galvanized

Service: Upper attachment for suspending pipe or conduit from concrete ceiling.

Approvals: Complies with Federal Specification A-A-1192A (Type 18), WW-H-171-E (Type 19), ANSI/MSS SP-69 and MSS SP-58 (Type 18). UL, ULC Listed and FM Approved (Sizes $\frac{3}{8}$ " - $\frac{3}{4}$ ").

Installation:

1. Nail insert to wooden forms.
2. Where convenient, reinforcing rods may be placed in the opening through the top of the insert, or short lengths of reinforcing rod may be wired to the insert prior to pouring concrete. However, note that the specified load ratings and approvals are not dependent on the use of any reinforcing rods in contact with the insert.
3. After concrete is poured and forms removed, insert screw driver into slot in knockout plate and snap it out.
4. The nut may be put on the rod before inserting in the insert body. Then, turn rod so that elongated nut lies across the slot; screw rod through nut until rod is firmly against the top of the recess.

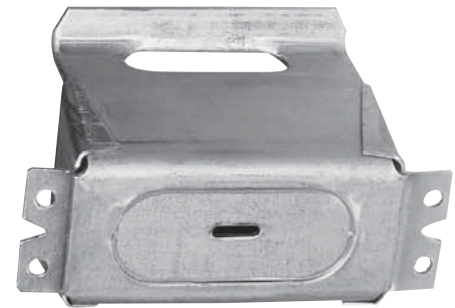

Features:

- Nut may be put on hanger rod before insertion, avoiding need of locating nut in insert body prior to inserting rod.
- Insert nut, when located in position, wedges against the sloping sides of insert, providing greater support than if resting on lower edge of the insert body.
- Wedge-shaped body is so held by concrete in compression thus increasing load carrying capacity.
- Easily removed knockout plate.
- Rod can be adjusted along complete length of slot.
- One body for six sizes of rod.

Ordering: Specify figure number, name and size of nut.

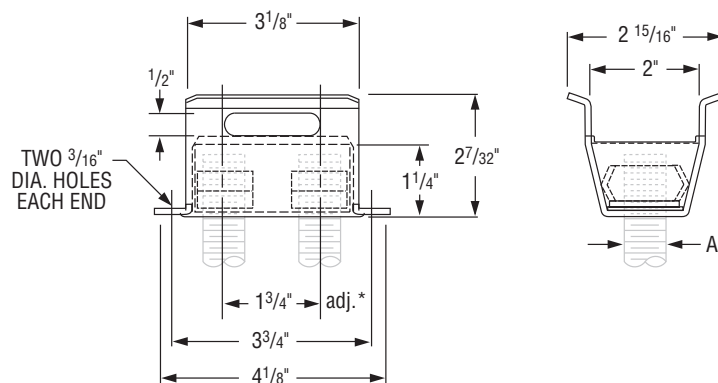

FIG. 281:
LOAD (LBS) • WEIGHT (LBS) • DIMENSIONS (IN)

	Rod Size A	Max Load ■	Weight
Insert Complete With Nut	$\frac{3}{8}$	730	0.82
	$\frac{1}{2}$	1,130	0.86
	$\frac{5}{8}$	1,200	0.89
	$\frac{3}{4}$		0.86
	$\frac{7}{8}$		0.93
Insert Only	—	—	0.69
Nut Only	$\frac{1}{4}$	—	0.13
	$\frac{3}{8}$	—	
	$\frac{1}{2}$	—	0.17
	$\frac{5}{8}$	—	0.20
	$\frac{3}{4}$	—	0.17
	$\frac{7}{8}$	—	0.24

■ Based on insert and nut only. Rating is subject to the condition that the concrete used is of sufficient strength to hold the insert.

Fig. 285

Light Weight Concrete Insert

Size Range: 1/4" through 5/8"

Material: Carbon steel

Finish: Plain or Galvanized

Service: Upper attachment for suspending pipe or conduit from concrete ceiling.

Approvals: Complies with Federal Specification A-A-1192A (Type 18), WW-H-171-E (Type 18), ANSI/MSS SP-69 and MSS SP-58 (Type 19).

UL, ULC Listed (Sizes 3/8" - 5/8") and FM Approved (Sizes 3/8" and 1/2").

Installation:

1. Nail insert to wooden forms.
2. Reinforcing rods may be located under the arched flanges at the top of the insert. However, note that the specified load ratings and approvals are not dependent on the use of any reinforcing rods in contact with the insert.
3. After concrete is poured and wooden forms are removed, remove knockout by tapping along edge with pointed instrument.
4. Slip nut into insert and screw rod through nut until rod is firmly against the top of the insert body.

Features:

- Suitable for use in concrete 2" thick due to low overall height.
- Highly competitive.
- Provides for 2" of lateral adjustment.
- Knockout prevents seepage of concrete from underneath the insert up into the insert body.
- One body size.
- Removable nut in four sizes.
- Rod can be rigidly locked in position.

Ordering: Specify figure number, name, finish and size of nut.

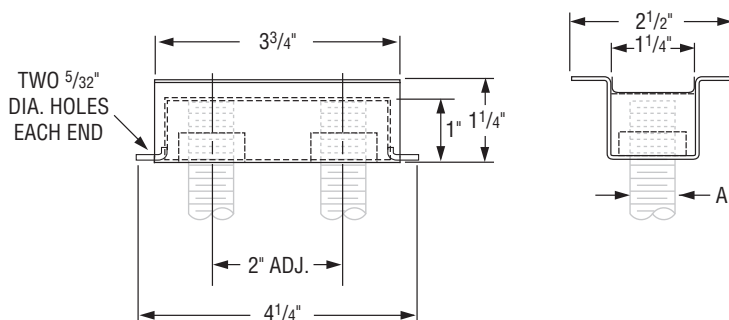

**FIG. 285:
LOAD (LBS) • WEIGHT (LBS) • DIMENSIONS (IN)**

	Rod Size A	Max Load ■	Weight
Insert Complete With Nut	1/4	230	0.46
	3/8	400	0.49
	1/2		0.49
	5/8		0.48
Insert Only	—	—	0.41
Nut Only	1/4	—	0.07
	3/8	—	
	1/2	—	
	5/8	—	

■ Based on insert and nut only. Rating is subject to the condition that the concrete used is of sufficient strength to hold the insert.

Fig. 286 (Formerly Fig. 283)

Iron Cross

Size Range: 3/4" through 1 1/2"

Material: Stainless steel body, fiberglass bars, polypropylene disc

Service: Upper attachment for suspending pipe or equipment from concrete ceiling.

Approvals: Complies with Federal Specification A-A-1192A (Type 18) WW-H-171-E (Type 18), ANSI/MSS SP-69 and MSS SP-58 (Type 18).

Installation:

1. Nail insert to wooden forms.
2. Locate fiberglass bars to rest upon existing reinforcing rods or wire the insert directly into existing reinforced rods to achieve the specified load ratings.

Features:

- Stainless steel body prevents corrosion.
- Cone shaped body.
- Exceptional pullout strength.
- Eliminates uncertainty of tying conventional inserts into bridge deck rebars.

Ordering: Specify figure number, name and rod size.

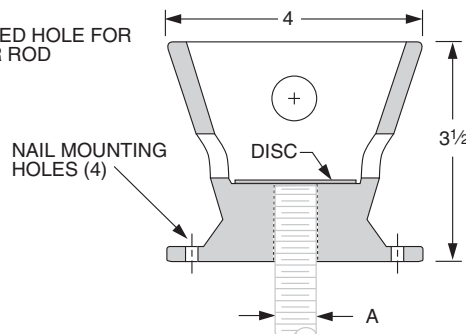
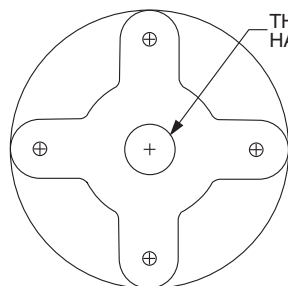
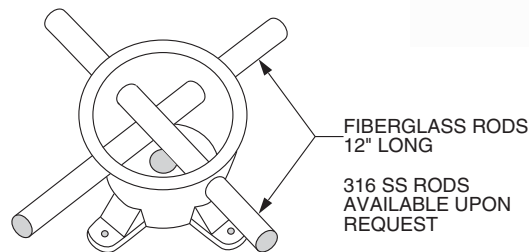
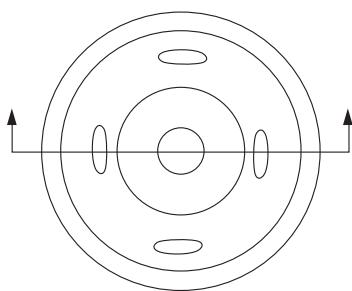

FIG. 286:

Rod Size A	Max Load (lbs) ■
3/4	3,230
7/8	4,480
1	5,900
1 1/4	9,500
1 1/2	13,800

■ Based on the rod diameter only. Rating is subject to the conditions that the concrete used is of sufficient strength to hold the insert.

Fig. 284

Metal Deck Hanger

Size Range: 3/8" through 3/4"

Material: Carbon steel

Finish: Plain

Service: Recommended for suspending pipe or conduit in metal concrete deck forms for a variety of rod sizes. May be used with a rod coupling such as the Fig. 135 or 136 to allow for extended rod lengths.

Features:

- L and H can be specified for a custom fit if your particular deck does not accommodate type A, B, or C.
- Standard 6" long UNC bolt is welded to bracket to ensure assembly remains intact during shipment.

Ordering: Specify Figure 284, design type (A, B, C) and bolt diameter. If your specific deck will not fit one of the design types and/or a different bolt size is required, specify leg height (H), opening (L) and bolt size.

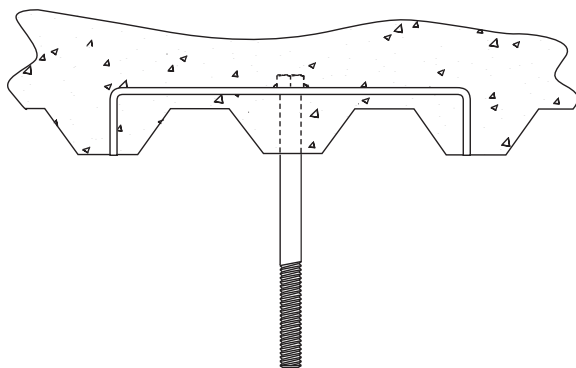

Before pouring concrete, locate the Figure 284 on deck so legs rest in "valleys" of form. Drill hole in deck for bolt.

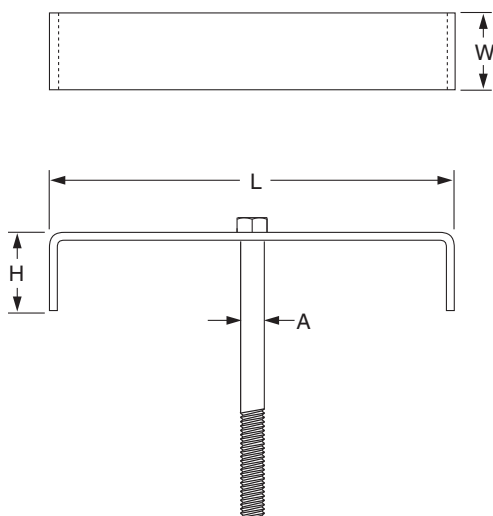

FIG. 284:
LOAD (LBS) • WEIGHT (LBS) • DIMENSIONS (IN)

Type	Bolt Size A	Max Load ■	L	H	W	Weight
A	3/8	730	9 5/8	1 3/4	1 1/2	1.33
	1/2	1,350				1.43
	5/8	2,160				1.64
	3/4	3,230				1.92
B	3/8	730	12	3	1 1/2	2.23
	1/2	1,350				2.33
	5/8	2,160				2.54
	3/4	3,230				2.82
C	3/8	730	16	4	1 1/2	3.10
	1/2	1,350				3.20
	5/8	2,160				3.41
	3/4	3,230				3.69

■ Based on the rod diameter only. Rating is subject to the conditions that the concrete used is of sufficient strength to hold the deck hanger.

Fig. 47

Concrete Single Lug Plate

Size Range: 1/2" through 2"

Material: Carbon steel

Finish: Plain or Galvanized

Service: Structural attachment to concrete ceiling lug is used in conjunction with Fig. 299 (see page 98) forged steel clevis and anchors of sufficient strength to hold the desired load.

Ordering: Specify rod size, figure number, name and finish.

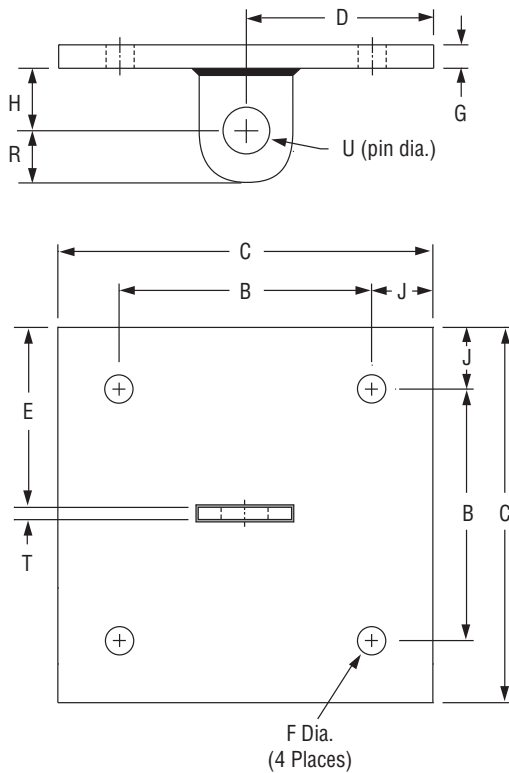

FIG. 47: LOAD (LBS) • WEIGHT (LBS) • DIMENSIONS (IN)

Rod Size A	Max Load ■	Weight	J	B	C	D	E	F	G	H	R	T	U
1/2	1,350	11.1	1	8	10	5	4 7/8	9/16	3/8	1 1/2	1 1/4	1/4	5/8
5/8	2,160	14.6					1/2	3/4					
3/4	3,230	14.8					4 13/16	11/16	3/4	2		3/8	7/8
7/8	4,480	22.0					5 3/4	13/16	1 1/2	1 1/8		1 1/8	1
1	5,900	31.9	2	12	12	6	5 11/16	15/16	1	3	2 1/2	1/2	1 3/8
1 1/4	9,500	43.8					5 5/8	1 1/8	3/4				1 1/8
1 1/2	13,800	45.6					1 3/8	1 1/4	4	3		3/4	1 7/8
1 3/4	18,600	55.7					2 1/4	2 1/4					
2	24,600	58.2											2 1/4

■ Based on the rod diameter only. Rating is subject to the conditions that the concrete and anchors used are of sufficient strength to hold the load.

Fig. 49

Concrete Clevis Plate

Size Range: 3/8" through 1 3/4"

Material: Carbon steel

Finish: Plain or Galvanized

Service: Structural attachment to concrete ceiling where flexibility is desired. Concrete clevis plate is normally used in conjunction with Fig. 290, page 97, weldless eye nut, or Fig. 278, page 93 welded eye rod and anchors of sufficient strength to hold the desired load.

Ordering: Specify rod size, figure number, name and finish.

Note: Sizes 3/8" through 1" are supplied with bolt and nut. Larger sizes are supplied with pin and cotters.

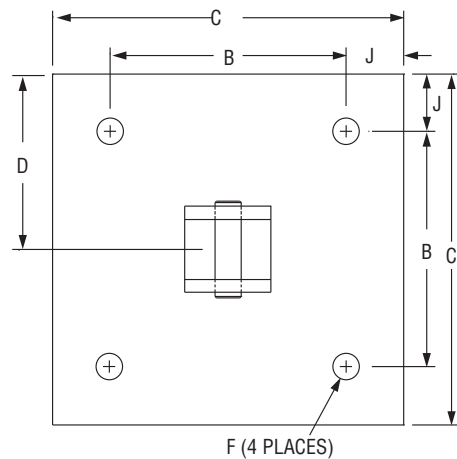
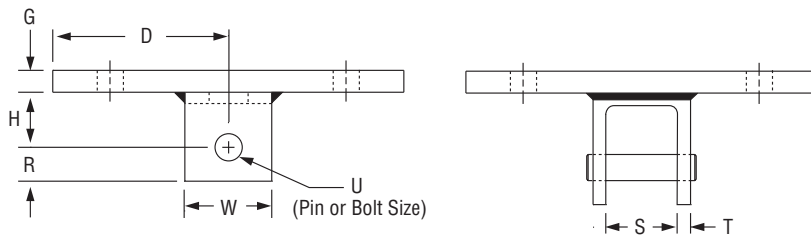

FIG. 49: LOAD (LBS) • WEIGHT (LBS) • DIMENSIONS (IN)

Rod Size A	Max Load ■	Weight	J	B	C	D	F	G	H	R	S	T	U	W			
3/8	730	11.8	1	8	10	5	9/16	3/8	2	7/8	1 1/4	1/4	1/2	2			
1/2	1,350	11.9											5/8				
5/8	2,160	15.7					3/4										
3/4	3,230	16.9					2	12	6	1 1/16	1/2	3	1 1/8	1 7/8	3/8	7/8	2 1/2
7/8	4,480	18.1								1							
1	5,900	36.9	1 3/16	3/4	3	1 1/2				2 1/2	1/2	1 1/8	3				
1 1/4	9,500	40.9	2	10	14	7	15/16	1	4	2 1/2	3	3/4	1 3/8	5			
1 1/2	13,800	59.8					1 1/8						1 5/8		4		
1 3/4	18,600	93.6					1 3/8	1 3/4	5	2 3/4	3 1/2	1/2	1 7/8	5			

■ Based on the rod diameter only. Rating is subject to the conditions that the concrete and anchors used are of sufficient strength to hold the load.

- Pictorial Table of Contents
- General Notes
- Copper Tubing Hangers
- CPVC Pipe Hangers
- Pipe Rings
- Clevis Hangers
- Steel Pipe Clamps
- Socket Clamps
- Beam Clamps
- Structural Attachments
- Brackets
- Ceiling Plates & Flanges
- Concrete Inserts & Attachments
- Hanger Rods
- Rod Attachments
- Bolts, Nuts, Pins & U-Bolts

Fig. 52

Concrete Rod Attachment Plate

Size Range: 3/8" through 1 1/4"

Material: Carbon steel

Finish: Plain or Galvanized

Service: Structural attachment to concrete ceiling where vertical adjustment is desired. Normally used with threaded rod and nut and anchors of sufficient strength to hold the desired load.

Ordering: Specify rod size, figure number, name and finish.

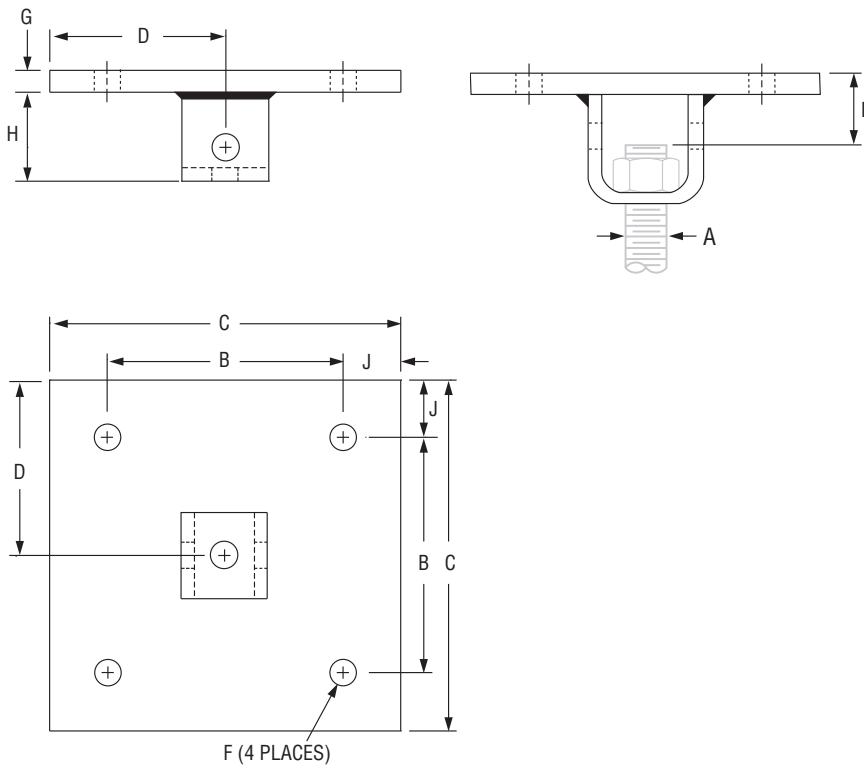

FIG. 52: LOAD (LBS) • WEIGHT (LBS) • DIMENSIONS (IN)

Rod Size A	Max Load ■	Weight	J	B	C	D	E	F	H	G
3/8	730	11.6	1	8	10	5	2 1/4	9/16	2 7/8	3/8
1/2	1,350	11.6					2 1/8			
5/8	2,160	15.1					2 1/4	1 1/16	3 3/8	1/2
3/4	3,230	16.1					3 3/8			
7/8	4,480	16.7	2	12	12	6	3 1/2	1 3/16	4 1/2	3/4
1	5,900	34.9					3 5/8			
1 1/4	9,500	40.9					1 5/16	5		

■ Based on the rod diameter only. Rating is subject to the conditions that the concrete and anchors used are of sufficient strength to hold the load.

Fig. 142

Coach Screw Rods Machine Threaded on Opposite End

Size Range: $\frac{3}{8}$ " and $\frac{1}{2}$ "

Material: Carbon steel

Finish: Plain

Ordering: Specify rod size, figure number, name and rod length.

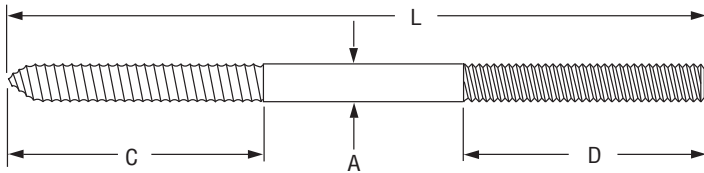

FIG. 142: STANDARD THREAD LENGTHS (IN) • LOADS (LBS)

Rod Size A	Standard Length - L	Coach Screw Thread Length - C	Standard Rod Thread Length - D	Max Load
$\frac{3}{8}$	$3\frac{1}{2}$	2	$\frac{3}{4}$	390
	8		$2\frac{1}{2}$	
$\frac{1}{2}$	$3\frac{1}{2}$	$2\frac{7}{16}$	$\frac{3}{4}$	640
	8		$2\frac{1}{2}$	

Fig. 146

Continuous Threaded Rod

Size Range: $\frac{1}{4}$ " through $1\frac{1}{2}$ " Stocked in six, ten, and twelve foot lengths. Other even foot lengths can be furnished to order.

Material: Carbon steel or Stainless Steel Gr 304

Threads: National Coarse (USS), rod threaded complete length.

Finish: Plain or Galvanized.

Maximum Temperature: 650° F.

Ordering: Specify rod diameter and length, figure number, name and finish.

Note: The acceptability of galvanized coatings at temperatures above 450°F is at the discretion of the end user.

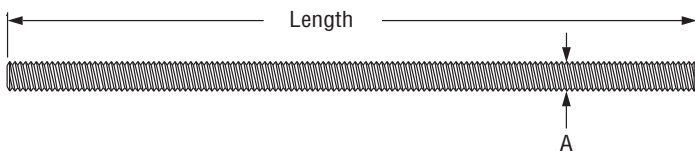

**FIG. 146:
LOADS (LBS) • WEIGHTS (LBS) • DIMENSIONS (IN)**

Rod Size A	Threads per Inch	Max Load 650° F	Weight per Ft.
$\frac{1}{4}$	20	240	0.12
$\frac{3}{8}$	16	730	0.30
$\frac{1}{2}$	13	1,350	0.53
$\frac{5}{8}$	11	2,160	0.84
$\frac{3}{4}$	10	3,230	1.20
$\frac{7}{8}$	9	4,480	1.70
1	8	5,900	2.30
$1\frac{1}{4}$	7	9,500	3.60
$1\frac{1}{2}$	6	13,800	5.10

Note: Other rod sizes available upon request. Class 2 fit is available upon request.

HANGER RODS

Fig. 140: Right-hand Threads

Fig. 253: Right and Left hand Threads

Machine Threaded Rods Threaded Both Ends

Size Range: $\frac{3}{8}$ " through 5"

Material: Carbon steel

Finish: Plain or Galvanized

Ordering: Specify rod size, figure number, name, rod length and finish. Specify thread length if other than standard.

Note: The acceptability of galvanized coatings at temperatures above 450°F is at the discretion of the end user.

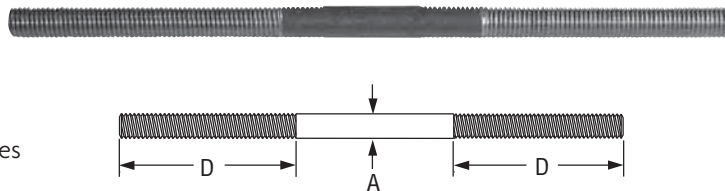

FIG. 140, 253: LOADS (LBS) • DIMENSIONS (IN)				
Rod Size A	Threads per Inch	Max Load		Standard Rod Thread Length D*
		650° F	750° F	
$\frac{3}{8}$	16	730	572	2½
$\frac{1}{2}$	13	1,350	1,057	
$\frac{5}{8}$	11	2,160	1,692	
$\frac{3}{4}$	10	3,230	2,530	3
$\frac{7}{8}$	9	4,480	3,508	3½
1	8	5,900	4,620	4
1¼	7	9,500	7,440	5
1½	6	13,800	10,807	6
1¾	5	18,600	14,566	7
2	4½	24,600	19,265	8
2¼	4½	32,300	25,295	9
2½	4	39,800	31,169	10

FIG. 140, 253: LOADS (LBS) • DIMENSIONS (IN) (CONT.)				
Rod Size A	Threads per Inch	Max Load		Standard Rod Thread Length D*
		650° F	750° F	
2¾	4	49,400	38,687	11
3	4	60,100	47,066	12
3¼	4	71,900	56,307	13
3½	4	84,700	66,331	14
3¾	4	98,500	77,139	15
4	4	113,400	88,807	
4¼	4 UN	129,400	101,337	18
4½	4 UN	146,600	114,807	
4¾	4 UN	164,700	128,982	
5	4 UN	184,000	144,096	

*Fig. 140 rod up to 1" rod size and 24" in length may be furnished as Fig 146 rod unless order states that all thread rod is not acceptable.

*¾"- 4" Diameter: UNC-2A CLASS fit.

Fig. 248: Right Hand Threads

Fig. 248L: Left Hand Threads

Eye Rod Not Welded

Size Range: $\frac{3}{8}$ " through 2½"

Material: Carbon steel

Finish: Plain or Galvanized.

Maximum Temperature: 650° F

Features: Through 1½", inside diameter of eye will accommodate a bolt diameter ⅛" larger than rod diameter; 1¾" and larger, inside diameter of eye will take a bolt diameter ¼" larger than rod diameter.

Ordering: Specify rod diameter, figure number, name, rod length and finish. Specify thread length if other than standard.

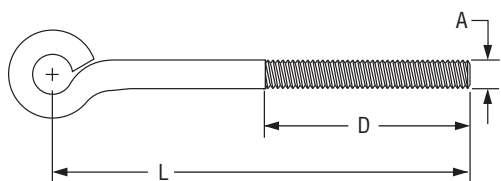

FIG. 248, FIG. 248L: LOADS (LBS) • DIMENSIONS (IN)			
Rod Size A	Standard Rod Thread Length – D	L (min)	Max Load 650° F
$\frac{3}{8}$	2½	4¼	240
$\frac{1}{2}$		4½	705
$\frac{5}{8}$		5½	1,050
$\frac{3}{4}$	3	6½	1,470
$\frac{7}{8}$	3½	7¼	1,940
1	4	8¼	3,120
1¼	5	10	4,650
1½	6	12	6,380
1¾	7	14	8,280
2	8	15½	10,900
2¼	9	17	13,400
2½	10		

Fig. 278: Right Hand Threads Fig. 278L: Left Hand Threads

Eye Rod Welded



Size Range: 3/8" through 2 1/2"

Material: Carbon steel

Finish: Plain or Galvanized

Features: Through 1 1/2", inside diameter of eye will accommodate a bolt diameter 1/8" larger than rod diameter; 1 3/4" and larger, inside diameter of eye will take a bolt diameter 1/4" larger than rod diameter.

Maximum Temperature: 750° F

Ordering: Specify rod diameter, figure number, name, rod length and finish. Specify thread length if other than standard.

Note: The acceptability of galvanized coatings at temperatures above 450°F is at the discretion of the end user.

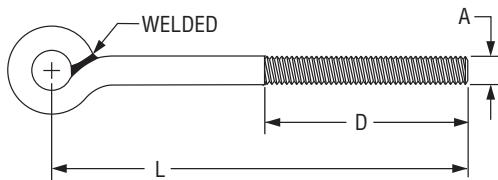

**FIG. 278, FIG. 278L:
LOADS (LBS) • DIMENSIONS (IN)**

Rod Size A	Standard Rod Thread Length - D	L (min)	Max Load	
			650° F	750° F
3/8	2 1/2	4 1/4	730	572
1/2			1,350	1,057
5/8		4 1/2	2,160	1,692
3/4	3	5 1/2	3,230	2,530
7/8	3 1/2	6 1/2	4,480	3,508
1	4	7 1/4	5,900	4,620
1 1/4	5	8 1/4	9,500	7,440
1 1/2	6	10	13,800	10,807
1 3/4	7	12	18,600	14,566
2	8	14	24,600	19,265
2 1/4	9	15 1/2	32,300	25,295
2 1/2	10	17	39,800	31,169

Fig. 248X: Not Welded Fig. 278X: Welded

Linked Eye Rods



Size Range: 3/8" through 2 1/2"

Service: The use of linked eye rods in a hanger assembly allows universal movement of the piping without bending and possible fracture of a straight rod.

Finish: Plain or Galvanized

Maximum Temperature: Fig. 248X: 650° F, Fig. 278X: 750° F

Ordering: Specify the size, length of each eye rod, figure number and finish.

Example:

7/8" Fig. 278X linked welded eye rod consisting of:

(L1) 7/8" Fig. 278 welded eye rod 1 ft. 2 1/2 in. long, center to end.

(L2) 7/8" Fig. 278 welded eye rod 1 ft. 2 1/2 in. long center to end.

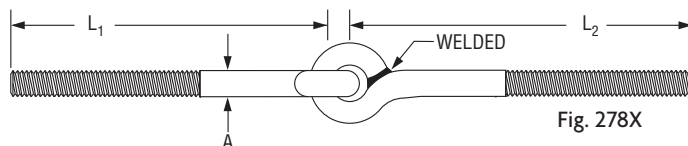
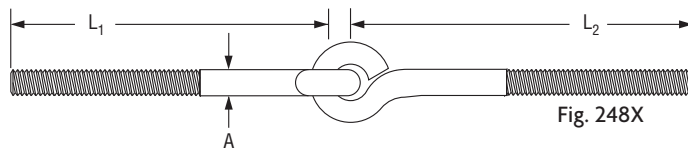

**FIG. 248X, 278X:
DIMENSIONS (IN) • LOADS (LBS)**

Rod Size A	Max Load		
	Fig. 248X 650° F	Fig. 278X	
		650° F	750° F
3/8	240	730	572
1/2	440	1,350	1,057
5/8	705	2,160	1,692
3/4	1,050	3,230	2,530
7/8	1,470	4,480	3,508
1	1,940	5,900	4,620
1 1/4	3,120	9,500	7,440
1 1/2	4,650	13,800	10,807
1 3/4	6,380	18,600	14,566
2	8,280	24,600	19,265
2 1/4	10,900	32,300	25,295
2 1/2	13,400	39,800	31,169

Fig. 148

Rod with Eye End

Size Range: 2 3/4" through 5"

Material: Carbon steel

Finish: Plain or Galvanized

Service: A large diameter rod with eye end for load ratings thru 184,000 pounds.

Ordering: Specify rod size, figure number, name, finish and "L" dimension. Indicate if desired thread length is other than standard.

Note: The acceptability of galvanized coatings at temperatures above 450°F is at the discretion of the end user.

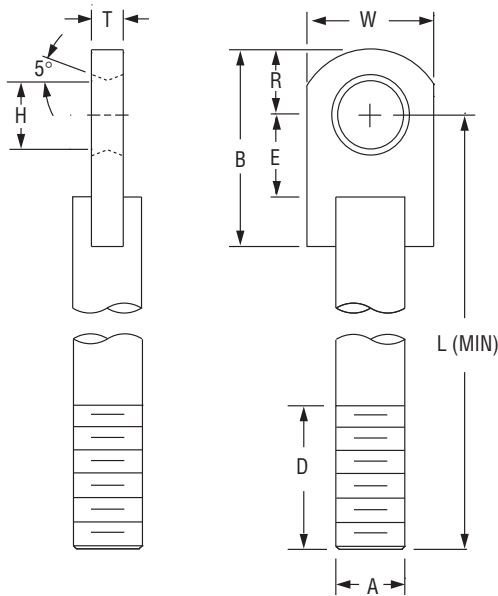

FIG. 148: LOADS (LBS) • WEIGHTS (LBS) • DIMENSIONS (IN)

Rod Size A	Max Load		Weight* Min Length	Weight/Ft. Additional Length	B	D	E	H	L (Min)	R	T	W
	650° F	750° F										
2 3/4	49,400	38,687	35.9	20	9 5/8	12	3 3/4	3 1/8	19	3 5/8	1 1/2	6
3	60,100	47,066	42.9	24	11		4	3 3/8	20	4		
3 1/4	71,900	56,307	54.7	28	12 1/4			3 5/8	21	4 1/4	7	
3 1/2	84,700	66,331	67.3	33	12 1/2	15	4 3/4	3 7/8	24	4 1/2	2	7 1/2
3 3/4	98,500	77,139	80.0	37	13 3/8		5	4 1/8	25	4 7/8		
4	113,400	88,807	97.0	43	15 1/8			4 3/8	26	5 1/8		
4 1/4 •	129,400	101,337	127.0	48	16 1/4	18	5 1/4	4 5/8	30	5 1/2	2 1/2	9 1/2
4 1/2 •	146,600	114,807	131.0	54	16		5 3/4	4 7/8		31		5 3/4
4 3/4 •	164,700	128,982	154.0	60	17			5 1/8	31	6		9 1/2
5 •	184,000	144,096	175.0	67	17 3/8	6 1/4	5 3/8	32	6 3/8	10		

*Weight calculated with minimum "L" for standard thread • Furnished with 4 UN series threads

Fig. 135: Straight with Sight-Hole

Rod Coupling

Fig. 135E: Straight Less Sight-Hole

Fig. 135R: Reducing

Size Range: 1/4" through 1"

Material: Carbon steel

Finish: Fig. 135: Plain; Fig.135E and Fig.135R Galvanized

Service: For connecting rods to accommodate up to 1" diameter and support up to 5,900 pounds.

Ordering: Specify rod size, figure number and name.

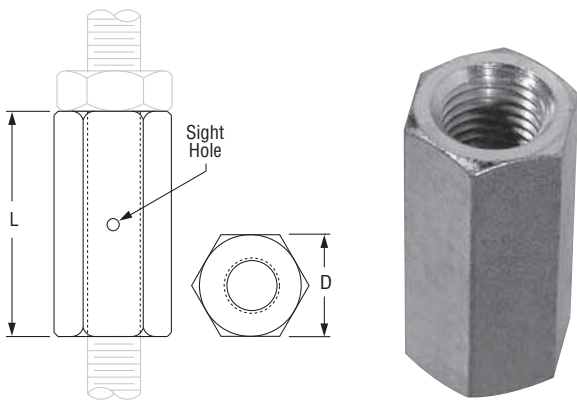

FIG 135, 135E, 135R: LOADS (LBS) • WEIGHTS (LBS) • DIMENSIONS (IN)				
Rod Size A	Max Load	Weight	D	L
Fig. 135: Straight With Sight-Hole				
3/8	730	0.09	9/16	1 1/8
1/2	1,350	0.12	3/4	1 1/2
5/8	2,160	0.24	19/16	1 7/8
3/4	3,230	0.42	1 1/8	2 1/4
7/8	4,480	0.66	1 5/16	2 5/8
1	5,900	1.00	1 1/2	3
Fig. 135E: Straight Less Sight-Hole				
1/4	240	0.03	3/8	7/8
3/8	730	0.09	5/8	1 1/8
1/2	1,350	0.14	11/16	1 3/4
5/8	2,160	0.26	19/16	2 1/8
3/4	3,230	0.34	1	2 1/4
7/8	4,480	0.55	1 1/4	2 1/2
1	5,900	0.75	1 3/8	2 3/4
Fig. 135R: Reducing				
3/8 x 1/4	240	0.13	5/8	1 1/2
1/2 x 3/8	730	0.13	11/16	1 1/4
5/8 x 1/2	1,350	0.19	13/16	1 1/4
3/4 x 5/8	2,160	0.26	1	1 1/2
7/8 x 3/4	3,230	0.41	1 1/4	1 3/4

Fig. 136: straight



Fig. 136R: Reducing



Rod Coupling

Size Range: 1/4" through 1"

Material: Malleable iron

Finish: Plain or Galvanized

Service: For connecting rod lengths within limitation.

Approvals: Fig. 136: UL, ULC Listed (3/8" - 7/8" rod size) and FM Approved (3/8" and 1/2" rod size). Fig. 136R: UL Listed (1/2" and 3/8" rod size).

Features:

- Available in reducing sizes.
- Provides visual inspection of thread engagement.
- Uniform strength; good appearance.

Ordering: Specify rod tapping size, figure number and name.

Furnished with right-hand UNC threads only.

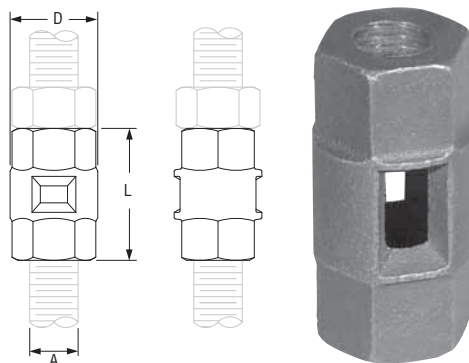

FIG. 136, 136R: LOADS (LBS) • WEIGHTS (LBS) • DIMENSIONS (IN)				
Rod Size A	Max Load	Weight	L	D
Straight: Fig. 136				
1/4	230	0.06	1 3/8	5/8
3/8	730	0.10	1 5/8	1 1/16
1/2	1,350	0.20	2 1/8	1 5/16
5/8	2,160	0.33	2 1/2	1 1/8
3/4	3,230	0.44	2 5/8	1 1/4
7/8	4,480	0.96	3 1/16	1 5/8
1	5,900	0.94	2 3/4	1 13/16
Reducing: Fig. 136R				
3/8 x 1/4	230	0.10	1 5/8	1 5/8
1/2 x 3/8	730	0.21	2 1/8	2 1/8

ROD ATTACHMENTS

Fig. 114

Turnbuckle Adjuster

Size Range: 1/4" through 3/4"

Material: Malleable iron

Finish: Plain

Installation: Normally used with split pipe ring, Fig. 108, see page 30.

Approvals: Complies with Federal Specification A-A-1192A (Type 15), WW-H-171-E (Type 15), ANSI/MSS SP-69 and MSS SP-58 (Type 15).

Maximum Temperature: 450° F

Features:

- An economical and simple means of obtaining vertical adjustment and flexibility at the pipe connection.
- Permits adjustment after pipe is in place.

Ordering: Specify rod size, figure number and name.

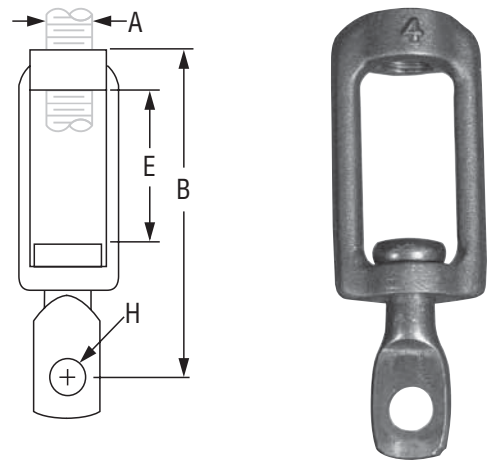

FIG. 114: LOADS (LBS) • WEIGHTS (LBS) • DIMENSIONS (IN)

Rod Size A	Max Load	Weight	B	E	H
1/4	230	0.09	2 1/2	1 1/4	7/32
3/8	730	0.28	3 7/8	1 7/8	13/32
1/2		0.31		1 13/16	
5/8		0.72		2 5/16	1/2
3/4	860	0.70	9/16		

Fig. 110R

Socket, Rod Threaded

Size Range: 1/4" through 7/8"

Material: Malleable iron

Finish: Plain

Service: For attaching hanger rod to various types of building attachments

Maximum Temperature: 450° F

Approvals: Complies with Federal Specification A-A-1192A (Type 16)

WW-H-171-E (Type 16), ANSI/MSS SP-69 and MSS SP-58 (Type 16).

UL Listed (Sizes 3/8" - 7/8") and FM Approved (Sizes 3/8" and 1/2").

Installation: Normally used with the split pipe ring Fig. 108, see page 30.

Ordering: Specify rod tapping size, figure number and name.

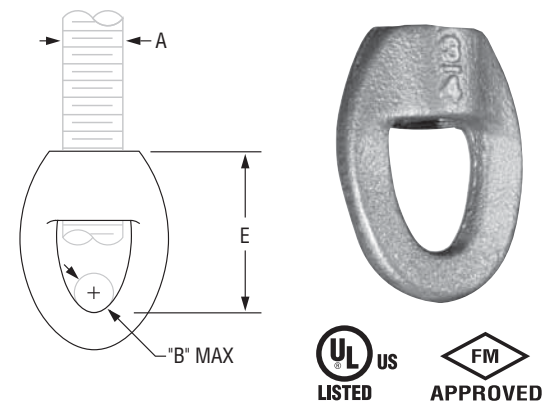

FIG. 110R: LOADS (LBS) • WEIGHTS (LBS) • DIMENSIONS (IN)

Rod Size A	Max Load	Weight	B	E
1/4	650	0.05	1/4	1 1/8
3/8	800	0.07		1 11/32
1/2	1,000	0.13		1 17/32
5/8	1,400	0.19	3/8	1 13/16
3/4	2,200	0.31	1/2	2 5/32
7/8	2,300	0.44		2 11/32

Fig. 157

Extension piece

Size Range: 3/8" through 7/8"

Material: Malleable iron

Finish: Plain or Galvanized

Maximum Temperature: 450° F

Service: For attaching hanger rod to various types of building attachments.

Approvals: UL Listed (3/8" - 7/8" rod size) and FM Approved (3/8" & 1/2" rod size).

Installation: May be used to form an integral part of malleable iron beam clamps Fig. 218, see page 64.

Ordering: Specify rod size, figure number, name and finish.

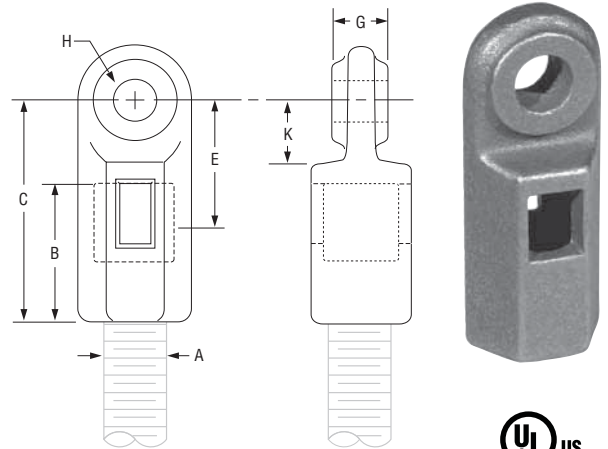

FIG. 157: LOADS (LBS) • WEIGHTS (LBS) • DIMENSIONS (IN)

Rod Size A	Max Load	Weight	B	C	Rod Take-Out - E	G	H	K
3/8	730	0.20	1 1/4	2 1/16	1 1/4	1/2	1/2	9/16
1/2	1,350	0.40	1 3/8	2 5/16	1 3/8	5/8		11/16
5/8	1,550	0.44	1 1/2	2 7/16	1 7/16		3/4	
3/4	2,100	0.65	1 3/4	2 7/8	1 11/16		7/8	
7/8	2,350	0.78	1 7/8	2	1 3/4		3/4	9/16

Fig. 290: Right-Hand Thread

Weldless Eye Nut

Fig. 290L: Left-Hand Thread

Size Range: 3/8" through 2 1/2"

Material: Forged steel

Finish: Plain or Galvanized

Service: For use on high temperature piping installations.

Approvals: Complies with Federal Specification A-A-1192A (Type 17), WW-H-171-E (Type 17), ANSI/MSS SP-69 and MSS SP-58 (Type 17).

Features:

- Supports loads equal to the full limitation of the hanger rod.
- Provides flexible connection when used with straight thread rod.

Ordering: Specify rod size, figure number, name and finish.

If other than standard combination of eye nut number and rod size, specify eye nut number and special rod tapping size.

Note: The acceptability of galvanized coatings at temperatures above 450°F is at the discretion of the end user. Larger eye nuts featuring smaller rod sizes are commonly available.

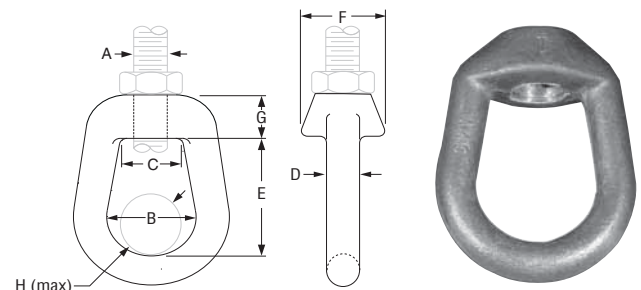

FIG. 290, 290L: LOADS (LBS) • WEIGHTS (LBS) • DIMENSIONS (IN)

Rod Size A	Max Load		Weight	B	C	D	E	F	G	H	Eye Nut Number
	650° F	750° F									
3/8	730	572	0.63	1 1/2	1 3/16	1/2	2	1 3/8	1 1/16	1 1/4	1
1/2	1,350	1,057	0.63								
5/8	2,160	1,692	0.62								
3/4	3,230	2,530	0.60								
7/8	4,480	3,508	1.70	2	1 11/16	3/4	2 5/8	1 15/16	1	1 3/4	2
1	5,900	4,620	1.70								
1 1/4	9,500	7,440	3.60	2 1/2	1 13/16	1	3 3/8	2 3/8	1 1/4	2 3/4	3
1 1/2	13,800	10,807	3.50								
1 3/4	18,600	14,566	16.40	4	4	1 1/2	6 1/4	4	2 1/4	3 3/4	4
2	24,600	19,265	15.90								
2 1/4	32,300	25,295	15.40								
2 3/4	39,800	31,169	14.90								

ROD ATTACHMENTS

Fig. 299

Forged Steel Clevis

Size Range: 3/8" through 4"

Material: Forged steel

Finish: Plain or Galvanized

Service: For use on high temperature piping installations.

Approvals: Complies with Federal Specification A-A-1192A (Type 14), WW-H-171-E (Type 14), ANSI/MSS SP-69 and MSS SP-58 (Type 14).

Features:

- Available with pin and cotter pins, if required.

Ordering: Specify rod size, figure number, name and finish. If pin and cotter pins are required, specify "with pin". If other than standard combination of clevis number and rod size is required, specify clevis number, special rod tapping size, pin size, grip.

Note: The acceptability of galvanized coatings at temperatures above 450°F is at the discretion of the end user.

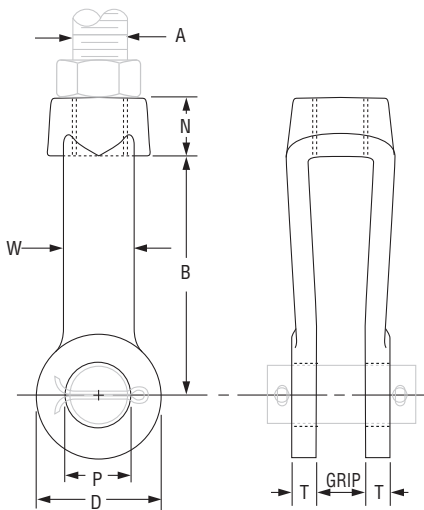

FIG. 299: LOADS (LBS) • WEIGHTS (LBS) • DIMENSIONS (IN)

Rod Size A	Max Load		Weight		Rod Take Out - B	D	N	Pin Dia. P	T	W	Grip	Clevis No.
	650° F	750° F	Without Pin	With Pin								
3/8	730	572	0.9	1.0	3 1/16	1 7/16	5/8	1/2	5/16	1 1/16	1/2	2
1/2	1,350	1,057	0.7	0.9				5/8			3/4	
5/8	2,160	1,692	0.7	0.9				7/8				
3/4	3,230	2,530	2.5	3.0	4	2 1/2	1	5/16	1 5/16	3/4	2 1/2	
7/8	4,480	3,508	2.5	3.4						7/8		
1	5,900	4,620	4.0	5.1	5	3	1 5/16	1/2	1 1/2	1	3	
1 1/4	9,500	7,440	3.8	5.5						1 3/8		
1 1/2	13,800	10,807	6.0	8.5	6	3 1/2	1 5/8	1/2	1 3/4	2	1 1/2	3 1/2
1 3/4	18,600	14,566	8.0	12.9							1 7/8	
2	24,600	19,265	16.0	23.3	7	5	2 1/4	5/8	2 1/2	2 1/2	5	
2 1/4	32,300	25,295	26.0	35.1							2 1/2	
2 1/2	39,800	31,169	25.5	36.0	8	6	2 3/4	3/4	3	2 1/2	6	
2 3/4	49,400	38,687	36.0	50.0							2 3/4	
3	60,100	47,066	35.0	51.5	9	7	3	7/8	3 1/2	3 1/2	7	
3 1/4	71,900	56,307	90.0	116.0							3	
3 1/2	84,700	66,331	88.0	118.0	10	8	4	1 1/2	4	4	8	
3 3/4	98,500	77,139	86.0	120.0								3 1/4
4	113,400	88,807	84.0	122.0								4

• Furnished with 4 UN series threads.

Fig. 230

Turnbuckle

Size Range: 3/8" through 2 1/2"

Material: Forged steel

Finish: Plain or Galvanized

Service: Provides adjustment up to 6" for 12" Fig. 230 and 3" for 6" Fig. 230.

Approvals: Complies with Federal Specification A-A-1192A (Type 13), WW-H-171-E (Type 13), ANSI/MSS SP-69 and MSS SP-58 (Type 13).

Ordering: Specify rod size, figure number, name and finish.

Note: The acceptability of galvanized coatings at temperatures above 450°F is at the discretion of the end user.

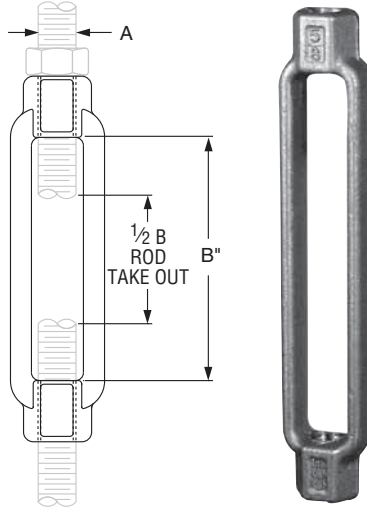

FIG. 230: LOADS (LBS) • WEIGHTS (LBS) • DIMENSIONS (IN)

Rod Size A •	Max Load		Weight	
	650°F	750°F	B= 6" Opening	B=12" Opening
3/8	730	572	0.42	–
1/2	1,350	1,057	0.65	1.20
5/8	2,160	1,692	0.98	1.58
3/4	3,230	2,530	1.50	2.35
7/8	4,480	3,508	1.90	4.05
1	5,900	4,620	2.60	4.02
1 1/4	9,500	7,440	4.50	–
1 1/2	13,800	10,807	6.40	–
1 3/4	18,600	14,566	11.00	–
2	24,600	19,265	14.90	–
2 1/4	32,300	25,295	19.60	–
2 1/2	39,800	31,169	26.90	–

• Tapped right hand and left hand thread. Larger rod sizes or openings available upon request

Fig. 233

Turnbuckle

Size Range: 1 1/4" through 5"

Material: Carbon steel

Finish: Plain or Galvanized

Services: Provides adjustments up to 12" with loads up thru 184,000 pounds.

Approvals: Complies with Federal Specification A-A-1192A (Type 13), WW-H-171-E (Type 13), ANSI/MSS SP-69 and MSS SP-58 (Type 13).

Ordering: Specify rod size, figure number, name, finish and opening dimension.

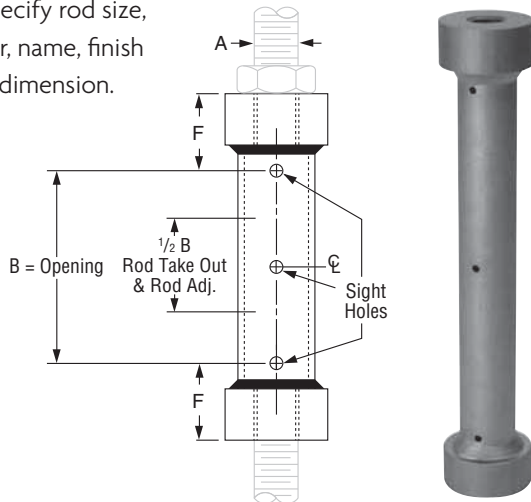

FIG. 233: LOADS (LBS) • WEIGHTS (LBS) • DIMENSIONS (IN)

Rod Size* A	Max Load	Weight/Opening				F
		B= 6"	B=12"	B=18"	B=24"	
1 1/4	9,500	–	9.0	10.8	12.6	2 1/8
1 1/2	13,800	–	12.4	14.9	17.4	2 3/8
1 3/4	18,600	–	11.7	14.2	16.7	
2	24,600	–	20.9	24.7	28.5	3 1/16
2 1/4	32,300	–	29.5	34.6	39.7	3 1/4
2 1/2	39,800	–	28.3	33.4	38.5	
2 3/4	49,400	35.6	41.8	48.1	54.3	3 1/2
3	60,100	41.6	49.1	56.6	64.1	3 13/16
3 1/4 •	71,900	39.6	47.0	54.5	62.0	
3 1/2 •	84,700	72.5	82.9	93.3	103.7	4 1/16
3 3/4 •	98,500	69.6	80.0	90.4	107.30	
4 •	113,400	110.7	125.1	139.4	153.6	5
4 1/4 •	129,400	107.1	121.5	135.7	150.0	
4 1/2 •	146,600	233.5	255.2	276.9	298.6	6 13/16
4 3/4 •	164,700	227.6	249.3	271.0	292.7	
5 •	184,000	221.4	243.1	264.8	286.5	

• Furnished with 4 UN series threads. *Tapped right hand and left hand thread.

Fig. 291

Clevis Pin with Cotters

Size Range: 1/2" through 4"

Material: Carbon steel

Finish: Plain or Galvanized

Maximum Temperature: 650° F

Service: For use with type C variable spring hanger, type C constant support (Fig. 81-H only) and Fig. 66 welded beam attachment.

Ordering: Specify pin diameter, figure number, name, finish and if cotter pins are required.

Note: The acceptability of galvanized coatings at temperatures above 450° F is at the discretion of the end user.

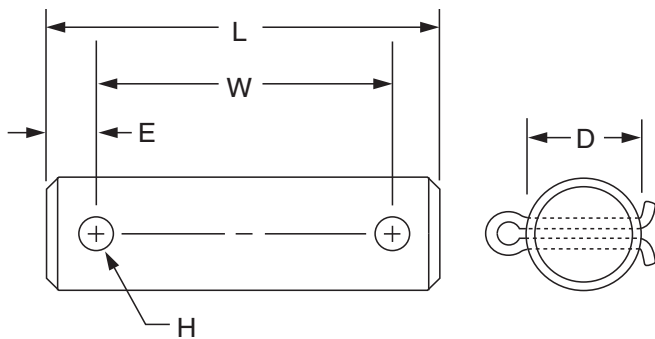
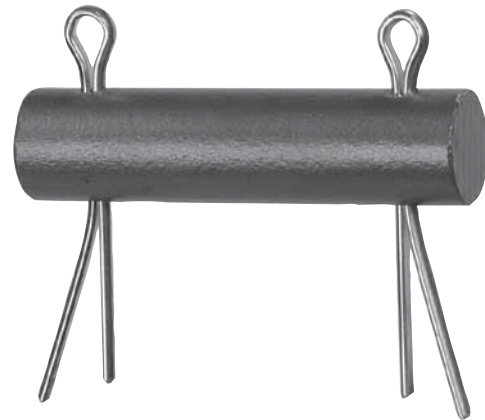

FIG. 291: LOADS (LBS) • WEIGHTS (LBS) • DIMENSIONS (IN)

Pin Dia. D	Max Load		Weight	L	W	E	H	Cotter Pin Size
	650° F	750° F						
1/2	730	572	0.12	2 7/8	2 1/8	3/8	5/32	1/8 x 1 1/4
5/8	1,350	1,057	0.18	3 1/8	2 3/8		7/32	3/16 x 1 1/2
3/4	2,160	1,691	0.29	3 5/8	2 7/8			
7/8	3,230	2,529	0.47	4 1/4	3 1/2			
1	4,480	3,508	0.67	4	3 3/4	1/2	9/32	3/16 x 2
1 1/8	5,900	4,620	1.00	4 3/4	4			
1 1/8	9,500	7,439	2.10	5 3/8	4 3/8	5/8	3/8	1/4 x 2 1/2
1 5/8	13,800	10,805	3.30	6	5			
1 7/8	18,600	14,564	4.80	7 1/8	5 7/8	3/4	1/2	3/8 x 3
2 1/4	24,600	19,262	7.20					
2 1/2	32,300	25,291	9.30	7 5/8	6 3/8			3/8 x 3 1/4
2 3/4	39,800	31,163	12.50	7 7/8	6 5/8			3/8 x 3 3/4
3	49,400	38,680	16.60	8 1/4	6 3/4	3/4	1/2	3/8 x 4
3 1/4	60,100	47,058	20.00	8 1/2	7			
3 1/2	71,900	56,298	23.90	8 3/4	7 1/4			1/2 x 5
3 3/4	84,700	66,320	25.10	9 1/2	8			1/2 x 6
4	98,500	77,125	34.80	9 3/4	8 1/4			

Machine Bolts

Size Range: American Standard hexagon head bolts with American Standard hexagon nuts are stocked in sizes $\frac{3}{8}$ " through $1\frac{1}{8}$ " UNC thread series. Other sizes are available upon request. Lengths of bolts are measured from under head to extreme point.

Finish: Plain or Electroplated

Ordering: Specify bolt size, name and length.

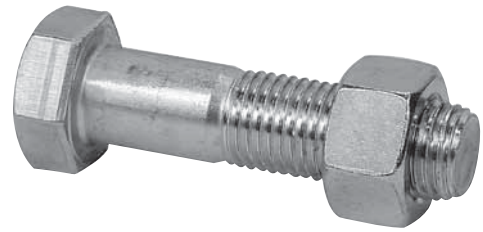

Hexagon Nuts

Size Range:

- American Standard hexagon nuts - sizes $\frac{1}{4}$ " thru $1\frac{1}{2}$ ".
- American Standard heavy hexagon flat nuts - sizes $1\frac{3}{4}$ " thru $3\frac{3}{4}$ ".

Finish: Plain or Electroplated

Ordering: Specify bolt or rod size and name.

HEX NUTS: DIMENSIONS (IN)		
Bolt /Rod Size	Width	Thickness
$\frac{1}{4}$	$\frac{7}{16}$	$\frac{15}{64}$
$\frac{3}{8}$	$\frac{9}{16}$	$\frac{11}{32}$
$\frac{1}{2}$	$\frac{3}{4}$	$\frac{29}{64}$
$\frac{5}{8}$	$\frac{15}{16}$	$\frac{9}{16}$
$\frac{3}{4}$	$1\frac{1}{8}$	$\frac{43}{64}$
$\frac{7}{8}$	$1\frac{5}{16}$	$\frac{25}{32}$
1	$1\frac{1}{2}$	$\frac{57}{64}$
$1\frac{1}{4}$	$1\frac{7}{8}$	$1\frac{3}{32}$
$1\frac{3}{8}$	$2\frac{1}{16}$	$1\frac{13}{64}$
$1\frac{1}{2}$	$2\frac{1}{4}$	$1\frac{5}{16}$

HEAVY HEX NUTS: DIMENSIONS (IN)		
Bolt /Rod Size	Width	Thickness
$1\frac{3}{4}$	$2\frac{3}{4}$	$1\frac{25}{32}$
2	$3\frac{1}{8}$	$2\frac{1}{32}$
$2\frac{1}{4}$	$3\frac{1}{2}$	$2\frac{19}{64}$
$2\frac{1}{2}$	$3\frac{7}{8}$	$2\frac{35}{64}$
$2\frac{3}{4}$	$4\frac{1}{4}$	$2\frac{13}{16}$
3	$4\frac{5}{8}$	$3\frac{1}{16}$
$3\frac{1}{4}$ ■	5	$3\frac{5}{16}$
$3\frac{1}{2}$ ■	$5\frac{3}{8}$	$3\frac{9}{16}$
$3\frac{3}{4}$ ■	$5\frac{3}{4}$	$3\frac{13}{16}$

■ Furnished with 8 UN or 4 UN threads as required.

- Pictorial Table of Contents
- General Notes
- Copper Tubing Hangers
- CPVC Pipe Hangers
- Pipe Rings
- Clevis Hangers
- Steel Pipe Clamps
- Socket Clamps
- Beam Clamps
- Structural Attachments
- Brackets
- Ceiling Plates & Flanges
- Concrete Inserts & Attachments
- Hanger Rods
- Rod Attachments
- Bolts, Nuts, Pins & U-Bolts**

Fig. 137: Standard U-bolt

Fig. 137S*: Special U-bolt (non-standard)

U-Bolts

Size Range: 1/2" through 36"

Material: Carbon steel U-bolt and four finished hex nuts

Finish: Plain or Galvanized

Service: Recommended for support, or guide of heavy loads; often employed in power, process plant and marine service.

Approvals: Complies with Federal Specification A-A-1192A (Type 24), WW-H-171-E (Type 24), ANSI/MSS SP-69 and MSS SP-58 (Type 24).

Ordering Fig. 137: Specify pipe size x rod size (e.g., 6 x 5/8), figure number, name. U-bolt will be furnished with longer tangents D or with longer threads E if so required and ordered. If hex nuts are not required, specify "without hex nuts".

Ordering Fig. 137S: Specify figure number, name, material specification, dimensions A, B, C, D, and E, and "with hex nuts" or "without hex nuts".

Note: The acceptability of galvanized coatings at temperatures above 450°F is at the discretion of the end user.



FIG. 137: LOADS (LBS) • WEIGHTS (LBS) • DIMENSIONS (IN) ■

Pipe Size	Rod Size A	Max Normal Load		650° F Max Side Load	Wt.	B	C	D	E	F		
		650° F	750° F									
1/2	1/4	580	454	145	0.11	15/16	13/16	23/4	21/8	25/16		
3/4					0.12	11/8	13/8			27/32		
1					0.12	13/8	15/8			23/32		
1 1/4	3/8	1,460	1,144	365	0.28	111/16	21/16	27/8	21/2	21/32		
1 1/2					0.30	2	23/8			3	21/16	
2					0.33	27/16	213/16			31/4	21/16	
2 1/2	1/2	2,700	2,114	675	0.73	215/16	37/16	33/4	3	25/16		
3					0.78	39/16	41/16			4	21/4	
3 1/2					0.84	41/16	49/16			41/4	27/32	
4					0.90	49/16	51/16			41/2	27/32	
5					1.0	55/8	61/8			5	27/32	
6	5/8	4,320	3,382	1,080	2.0	63/4	73/8	61/8	33/4	213/16		
8					2.3	83/4	93/8			71/8	213/16	
10	3/4	6,460	5,060	1,615	4.9	107/8	115/8	83/8	4	3		
12					7.7	127/8	133/4			95/8	41/4	31/4
14					8.3	141/8	15			101/4		
16	1	11,800	9,240	-	9.2	161/8	17	111/4	43/4	35/8		
18					13.5	181/8	191/8				125/8	
20					14.6	207/8	211/8				135/8	
24					16.9	241/8	251/8				155/8	
30					19.1	307/8	311/8				185/8	
36	23.2	367/8	371/8	215/8								

■ Loads, weights and dimensions shown do not apply for Fig. 137S. Max load rating for carbon steel is 2 x max load rating for rod size "A". Max load rating for stainless steel is 0.85 times the maximum stated load ratings listed above.

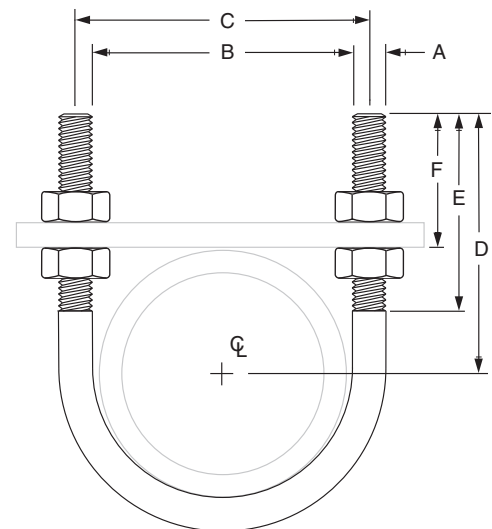

*When the combination of a normal load and a side load occurs, a straight line interaction formula may be used to determine if the Fig. 137 is still within the allowable stress range:

$$P_n/P_{na} + P_s/P_{sa} \leq 1$$

Where:

P_n = actual applied normal load;

P_{na} = allowable normal load for the Fig. 137;

P_s = actual applied side load;

P_{sa} = allowable side load for the Fig. 137

Nuts must be snug tight in installation to achieve side loads shown.

Fig. 137C: Plastic Coated

U-Bolts

Size Range: 1/2" through 8"

Material: Carbon steel U-bolt and four finished hex nuts. Formed portion of the U-bolt is plastic coated.

Maximum Temperature: 225° F

Service: Recommended for support or guide for glass, copper, brass and aluminum pipe.

Approvals: Complies with Federal Specification A-A-1192A (Type 24), WW-H-171-E (Type 24), ANSI/MSS SP-69 and MSS SP-58 (Type 24).

Ordering: Specify pipe size x rod size (e.g., 2 x 3/8), figure number and name. If hex nuts are not required, specify "without hex nuts".

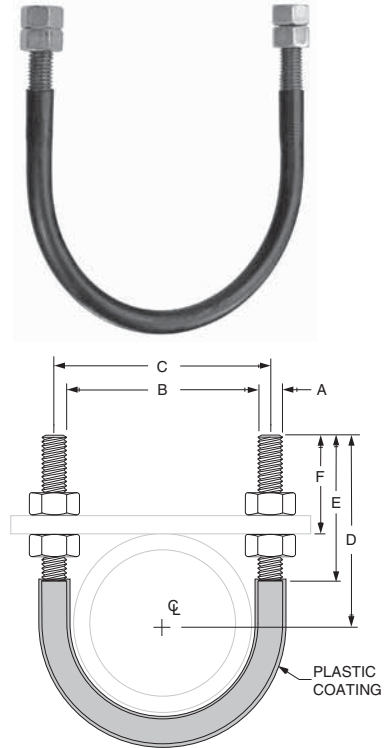

FIG. 137C: LOADS (LBS) • WEIGHTS (LBS) • DIMENSIONS (IN)

Pipe Size	Rod Size A	Max Load	Weight	B	C	D	E	F
1/2	1/4	580	0.11	15/16	13/16	23/4	21/8	25/16
3/4			0.12	17/8	13/8			27/32
1			0.12	13/8	15/8			23/32
1 1/4	3/8	1,460	0.28	111/16	2	27/8	21/2	21/32
1 1/2			0.30	2	23/8	3		21/16
2			0.33	27/16	213/16	31/4		21/16
2 1/2	1/2	2,700	0.73	215/16	37/16	33/4	3	25/16
3			0.78	39/16	41/16	4		21/4
3 1/2			0.84	41/16	49/16	41/4		21/4
4			0.90	49/16	51/16	41/2		27/32
5			1.00	55/8	61/8	5		21/16
6	5/8	4,320	2.00	63/4	73/8	61/8	33/4	213/16
8			2.30	83/4	93/8	71/8		213/16

Fig. 120

Light Weight U-Bolt

Size Range: 1/2" through 10"

Material: Carbon steel

Finish: Plain or Galvanized

Service: Recommended for support, or guide of relatively light loads. Normally used with two hex nuts.

Maximum Temperature: 650° F.

Ordering: Specify pipe size x rod size, figure number and name. Hex nuts must be ordered separately.

Note: The acceptability of galvanized coatings at temperatures above 450°F is at the discretion of the end user.

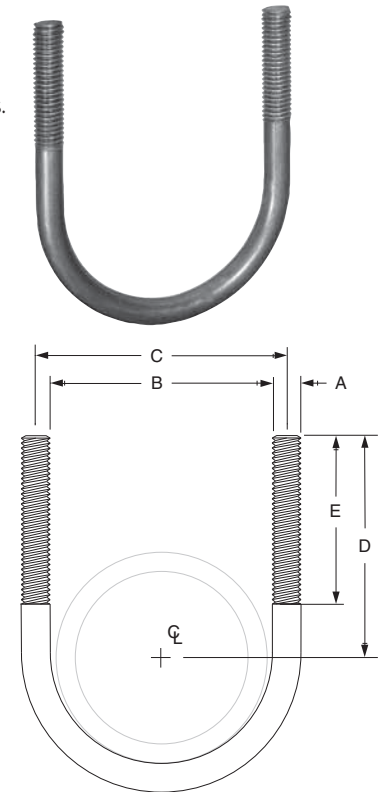

FIG. 120: LOADS (LBS) • WEIGHTS (LBS) • DIMENSIONS (IN)

Pipe Size	Max Load	Weight	Rod Size A	B	C	D	E
1/2	580	0.06	1/4	15/16	13/16	115/16	13/4
3/4		0.07		17/8	13/8	21/16	
1		0.07		13/8	15/8	23/16	
1 1/4		0.08		111/16	15/16	23/8	
1 1/2		0.09		2	21/4	27/16	
2		0.10		27/16	211/16	211/16	
2 1/2	1,460	0.28	3/8	215/16	35/16	31/16	2
3		0.31		39/16	315/16	33/8	
3 1/2		0.35		41/16	47/16	35/8	
4		0.38		49/16	415/16	37/8	
5		0.45		55/8	6	49/16	
6	2,700	0.95	1/2	63/4	71/4	51/16	21/4
8		1.20		83/4	91/4	61/16	
10		4,320		2.30	107/8	111/2	

Fig. 262

Strap Short

Size Range: 1/2" through 4"

Material: Carbon steel

Finish: Plain or Galvanized

Maximum Temperature: 650° F

Approvals: Complies with Federal Specification A-A-1192A (Type 26), WW-H-171-E (Type 26), ANSI/MSS SP-69 and MSS SP-58 (Type 26).

Ordering: Specify pipe size, figure number, name and finish.

Note: The acceptability of galvanized coatings at temperatures above 450°F is at the discretion of the end user.

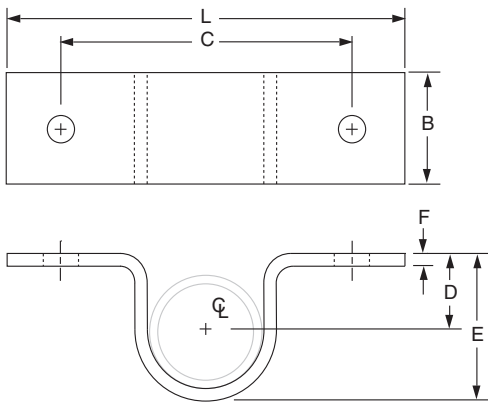

FIG. 262: LOADS (LBS) • WEIGHTS (LBS) • DIMENSIONS (IN)

Pipe Size	Max Load		Weight	Screw or Bolt Size ■	L	B	C	D	E	F
	w/Lag Screws	w/Bolts to Steel								
1/2	300	410	0.20	Two #18 x 2 steel wood screws or two 3/8" bolts to steel	4	1 1/4	2 3/4	1/2	1 1/8	1/8
3/4			0.23		4 3/8		3 1/8	1 1/16	1 7/16	
1			0.26		4 3/4		3 1/2	1 1/16	1 5/8	
1 1/4			0.36		5		3 3/4	1 1/16	2 1/8	
1 1/2			0.54		5 3/8		4 1/8	1 3/8	2 1/2	
2	450	610	0.60	Two #18 x 3 steel wood screws or two 3/8" bolts to steel	6 3/8	1 1/2	5 1/8	1 1/4	2 3/4	1/4
2 1/2			1.40		6 13/16		5 9/16	1 3/4	3 3/8	
3			1.60		7 3/16		6 1/16	1 7/8	4	
3 1/2			1.80		7 13/16		6 9/16	2 3/16	4 3/8	
4			1.90		8 3/8		7 1/8	2 5/8	5	

■ Screws or bolts not included

Fig. 126

One-Hole Clamp

Size Range: 3/8" through 4"

Material: Malleable iron

Finish: Plain or Galvanized

Service: For support of standard conduit, cable and steel pipe on walls or sides of beams. Not recommended for use horizontally on ceilings, bottoms of beams and similar installations since the factor of safety is greatly reduced when so used.

Maximum Temperature: 450° F

Ordering: Specify pipe size, figure number, name and finish. Specify nominal size of conduit or pipe or outside diameter of lead cable with which the clamp is to be used.

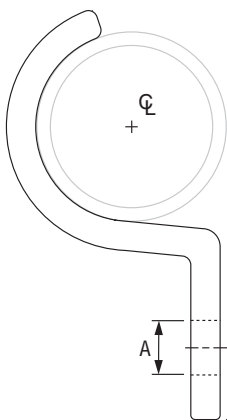

FIG. 126: WEIGHTS (LBS) • DIMENSIONS (IN)

Pipe Size	Cable Size or Outside Dia. of Conduit ■	Weight	Dia. of Hole - A	Size Screw/Bolt
3/8	0.67	0.03	1/4	No. 10
1/2	0.84	0.03	5/16	1/4
3/4	1.05	0.05		
1	1.31	0.09	3/8	3/8
1 1/4	1.66	0.12		
1 1/2	1.90	0.16	7/16	5/8
2	2.37	0.25		
2 1/2	2.87	0.49	1 1/16	5/8
3	3.50	0.82		
4	4.50	1.30	3/4	

■ Screws or bolts not included

Fig. 243

Pipe Strap

Size Range: 1/2" through 6" pipe

Material: Carbon steel

Finish: Plain

Service: Restraint of pipe in specified direction while permitting movement in non-restrained direction.

Maximum Temperature: 650° F

Ordering: Specify figure number, name, and pipe size. Larger sizes available upon request.

**FIG. 243:
LOADS (LBS) • WEIGHT (LBS) • DIMENSIONS (IN)**

Pipe Size	L	T	W	Rated Load P _n	Weight
1/2	3	1/4	2	600	0.71
3/4	3 1/2				0.84
1	4				0.98
1 1/4	4 1/2	3/8	3	1,500	2.64
1 1/2	5				2.94
2	5 1/2				3.39
2 1/2	6	1/2	4	2,500	5.20
3	6 1/2				7.93
4	7 1/2				9.63
6	9 3/4		6	3,000	19.97

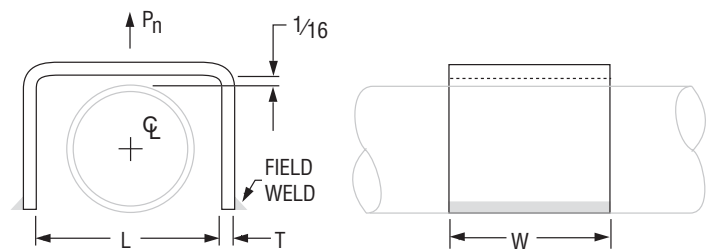

Fig. 244

Pipe Strap

Size Range: 1/2" through 6" pipe

Material: Carbon steel

Finish: Plain

Service: Restraint of pipe in specified direction while permitting movement in non-restrained direction.

Maximum Temperature: 650° F

Ordering: Specify figure number, name, and pipe size. Larger sizes available upon request.

**FIG. 244:
LOADS (LBS) • WEIGHT (LBS) • DIMENSIONS (IN)**

Pipe Size	Rated Load		L	T	W	Weight
	P _s	P _n				
1/2	250	1,500	1	1/4	2	0.39
3/4			1 3/16			0.47
1			1 7/16			0.56
1 1/4	500	2,000	1 3/4	3/8	3	1.62
1 1/2			2			1.81
2			2 1/2			2.20
2 1/2	650	2,300	3	1/2	4	3.56
3			3 7/8			5.74
4			4 3/4			7.16
6	700		6 3/4		6	15.32

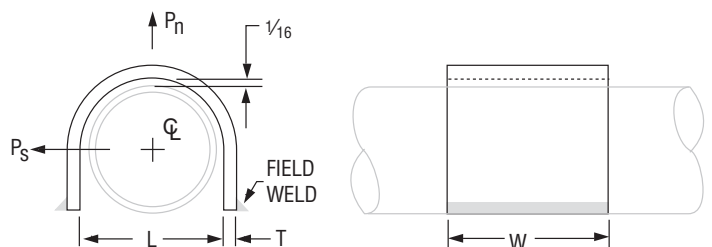

Fig. 62, Type A, B and C

Pipe Stanchion

Size Range: 2" through 18"

Material: Carbon steel

Finish: Plain or Galvanized

Service: Stanchion type of support for stationary pipe where vertical adjustment is required.

Maximum Temperature: Plain 650° F, Galvanized 450° F

Ordering: Specify figure number, type, pipe size, top stanchion size, material specification and "D" dimension. For base plates that require holes, also specify hole size, and the center line to center line of the holes.

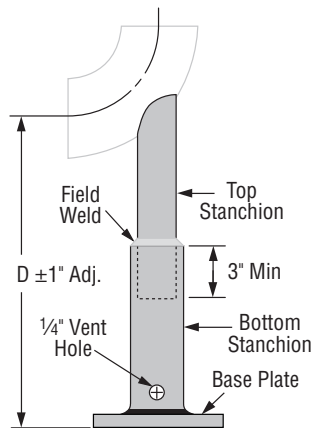

Fig. 62, Type A
(L. R. Elbow) with adjustable base

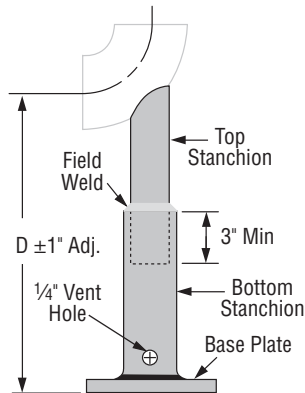

Fig. 62, Type B
(S. R. Elbow) with adjustable base

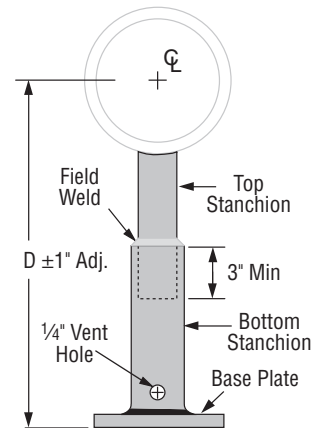

Fig. 62, Type C
(Horizontal Pipe) with adjustable base

Pipe or Elbow Size (in)	Top Stanchion Size (Standard Weight Pipe)			
	1½	2½	4	5
2	•			
2½	•			
3	•	•		
4	•	•		
5	•	•	•	
6		•	•	•
8			•	•
10			•	•
12				•
14				•
16				•
18				•
Weight (Lbs)	12	28	55	75

- Indicates available stanchion size for pipe or elbow size.
- Weights based on a "D" dimension of 2'-0".

DIMENSIONS (IN)		
Top Stanchion	Bottom Stanchion	Base Plate
1½	2 Std.	¾ x 6 x 6
2½	3 Std.	¾ x 10 x 10
4	5 Sch. 80	¾ x 10 x 10
5	6 Sch. 80	¾ x 10 x 10



Fig. 62
Stanchion with Adjustable Base

Fig. 63, Type A, B, C, P and T

Pipe Stanchion

Material: Carbon steel

Finish: Plain or Galvanized

Maximum Temperature: Plain 650° F, Galvanized 450° F

To Order Specify:

Type A, B, C: Figure Number, Type, Pipe Size, Stanchion Size, Material Specification and "D" Dimension.

Type P: Figure Number, Type, Saddle Size, Stanchion Size, Material Specification and "H" Dimension.

Type T: Figure Number, Type, Saddle Figure Number and Size, Stanchion Size, Material Specification and "H" Dimension.

For base plates that require holes, also specify hole size, and the center line to center line of the holes.

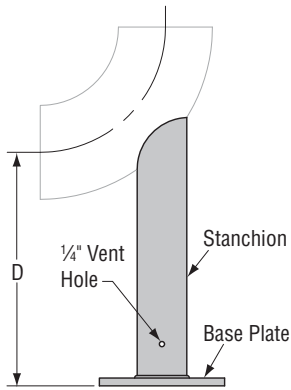

Fig. 63, Type A
(L. R. Elbow)

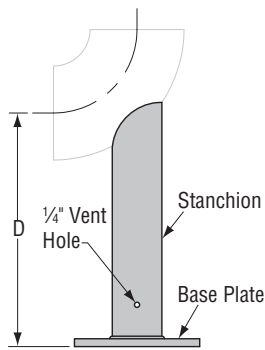

Fig. 63, Type B
(S. R. Elbow)

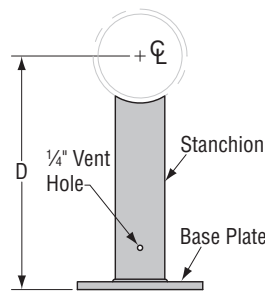

Fig. 63, Type C
(Horizontal Pipe)

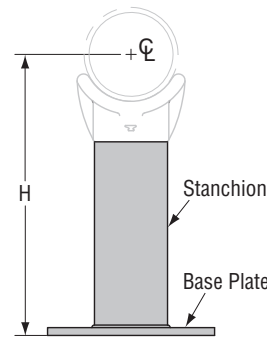

Fig. 63, Type P
Square Cut End for use
with Figure 258 or 259
Pipe Saddle Support
(See pages 109 & 112)

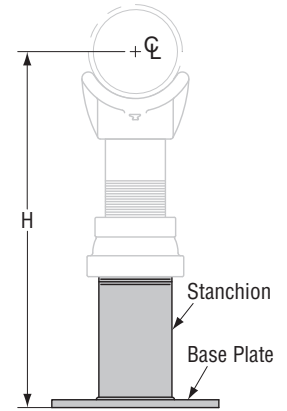

Fig. 63, Type T
Square Cut Threaded End
for use with Figure 264 or 265
Adjustable Pipe Saddle Support
(See pages 110 & 111)

Pipe or Elbow Size (in)	Stanchion Size (Standard Weight Pipe)													
	1½	2	2½	3	4	5	6	8	10	12	14	16	20	24
2½	•	•												
3	•	•	•											
4	•	•	•	•										
5	•	•	•	•	•									
6			•	•	•	•								
8				•	•	•	•							
10					•	•	•	•						
12						•	•	•	•					
14							•	•	•	•				
16								•	•	•	•			
18									•	•	•	•		
20										•	•	•	•	
22											•	•	•	•
24												•	•	•
26													•	•
28														•
30														•
32														•
34														•
36														•
42														•
Weight (Lbs)	9.5	11.6	16.4	23.7	31.8	47.0	59.0	100.0	164.0	201.0	230.0	282.0	374.0	515.0

• Indicates available stanchion size for pipe or elbow size for Types A, B, or C stanchions.

• Weights based on a "D" dimension of 2'-0".

See Figure 258, 259, 264, or 265 dimensional data for required stanchion pipe size (nominal pipe size A).

DIMENSIONS (IN)

Stanchion Size	Base Plate
1½	¾ x 6 x 6
2	
2½	¾ x 8 x 8
3	
4	¾ x 10 x 10
5	
6	¾ x 14 x 14
8	
10	½ x 18 x 18
12	
14	½ x 20 x 20
16	
20	½ x 24 x 24
24	
	½ x 30 x 30



Fig. 63
Stanchion

Fig. 192

Adjustable Pipe Saddle

Size Range: 2" through 12"

Material: Carbon steel

Finish: Plain or Galvanized

Service: Stanchion type support for **stationary** pipe where vertical adjustment is required.

Approvals: Complies with Federal Specification A-A-1192A (Type 38), ANSI/MSS SP-69 and MSS SP-58 (Type 38).

Ordering: Specify pipe size to be supported, figure number, name and finish.

FIG. 192: WEIGHTS (LBS) • DIMENSIONS (IN)

Pipe Size	Rod Size A	E	G	Weight
2	5/8	9 ⁷ / ₁₆	1/4 x 1	1.0
2 1/2		9 ¹¹ / ₁₆		1.4
3		10		1.6
3 1/2		10 1/4		2.6
4	7/8	10 1/2	1/4 x 1 1/4	3.0
5		11		3.2
6	1	11 ¹¹ / ₁₆	3/8 x 1 1/2	4.9
8		12 ¹¹ / ₁₆		6.2
10	1 1/4	13 ³ / ₈	1/2 x 2	10.5
12		14 ⁷ / ₈		11.8

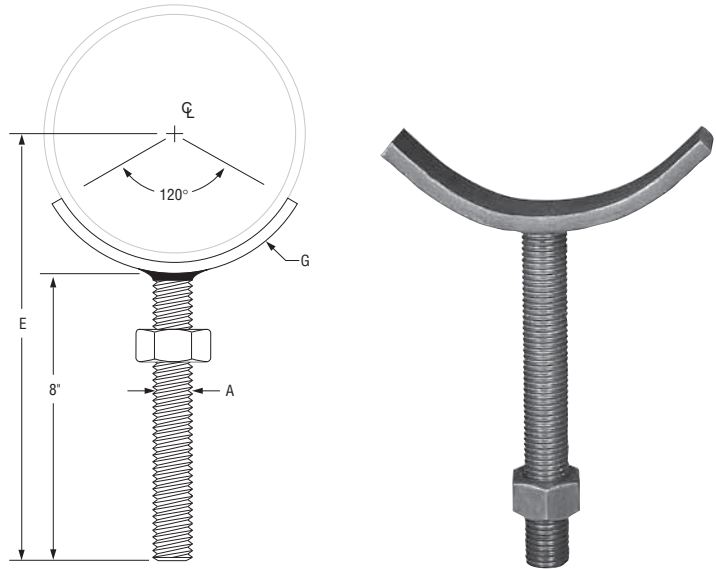

Fig. 191

Adjustable Pipe Saddle with U-Bolt

Size Range: 2" through 12"

Material: Carbon steel

Finish: Plain or Galvanized

Service: Stanchion type support where vertical adjustment is required, plus the additional **stability** provided by U-bolt attachment to **stationary** pipe.

Approvals: Complies with Federal Specification A-A-1192A (Type 37), ANSI/MSS SP-69 and MSS SP-58 (Type 37).

Ordering: Specify pipe size, figure number, name and finish.

FIG. 191: WEIGHTS (LBS) • DIMENSIONS (IN)

Pipe Size	Rod Size A	C	E	G	Weight
2	5/8	2 ¹¹ / ₁₆	9 ⁷ / ₁₆	1/4 x 1	1.2
2 1/2		3 ⁵ / ₁₆	9 ¹¹ / ₁₆		1.4
3		3 ¹⁵ / ₁₆	10		1.6
3 1/2		4 ⁷ / ₁₆	10 1/4		2.6
4	7/8	5 ¹ / ₄	10 1/2	1/4 x 1 1/4	3.0
5		6 ¹ / ₈	11		3.2
6	1	7 ¹ / ₄	11 ¹¹ / ₁₆	3/8 x 1 1/2	4.9
8		9 ³ / ₈	12 ¹¹ / ₁₆		6.2
10	1 1/4	11 1/2	13 ³ / ₈	1/2 x 2	10.5
12		13 1/2	14 ⁷ / ₈		11.8

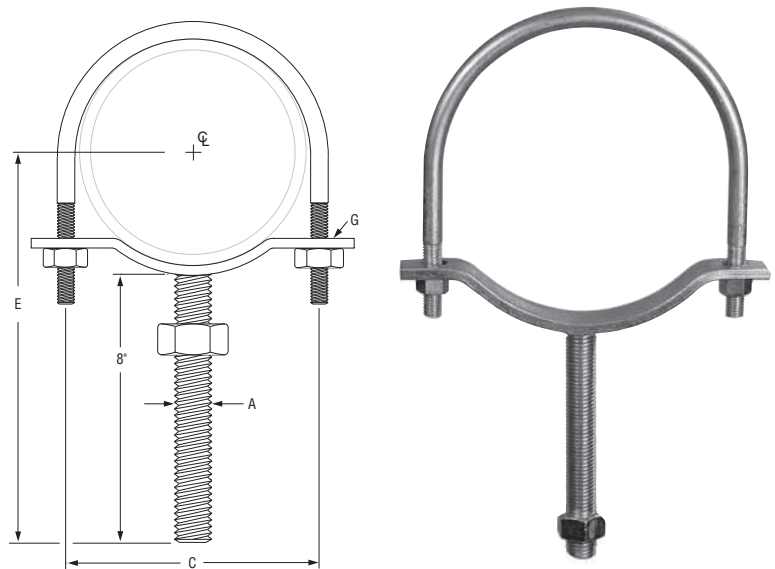

Fig. 258

Pipe Saddle Support

Size Range: 4" through 36"

Material: Sizes 4" through 12" are Cast Iron. Sizes 14" through 36" are Carbon Steel. Sizes 4" through 12" are available in Carbon Steel by special request only.

Finish: Plain or Galvanized

Service: Stanchion type support for **stationary** pipe.

Approvals: Complies with Federal Specification A-A-1192A (Type 36), WW-H-171-E (Type 36 & 37), ANSI/MSS SP-69 and MSS SP-58 (Type 36).

Installation: Slip saddle base into riser pipe.

Ordering: Specify size to be supported, figure number, name, finish and material.

Order Separately: Figure 63P Square Cut End Stanchion. Specify "H" and pipe size to be supported by Figure 258.



Fig. 258 Cast

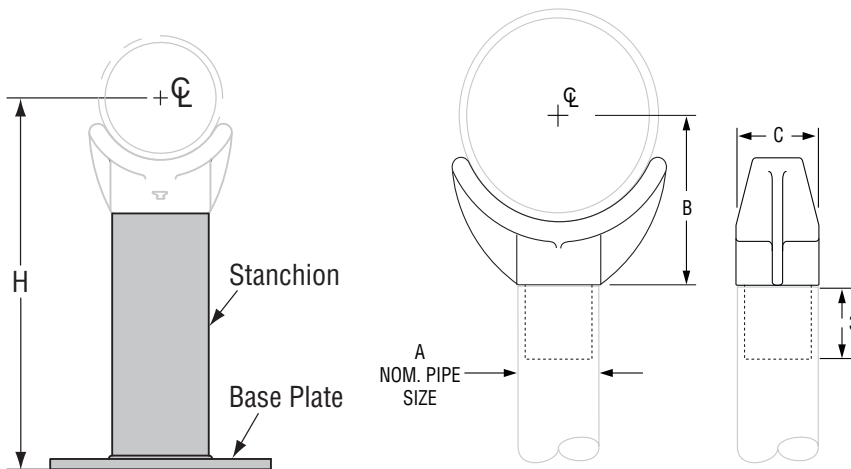

Fig. 63, Type P

Square Cut End for use with Figure 258 or 259 Pipe Saddle Support



Fig. 258 Fabricated Steel

FIG. 258: WEIGHTS (LBS) • DIMENSIONS (IN)

Pipe Size	Weight	A	B	Width C	Max Load
4	9.1	3	4 ³ / ₁₆	3 ⁵ / ₈	3,800
5	10.8		4 ¹³ / ₁₆		
6	11.8		5 ⁷ / ₁₆		
8	14.3		6 ¹⁵ / ₁₆		
10	19.3		8 ⁷ / ₁₆		
12	23.1		9 ¹⁵ / ₁₆		
14	15.0	4	10 ¹ / ₂	4	5,300
16	16.0		11 ¹ / ₂		
18	23.0		13 ¹ / ₂	5	6,700
20	24.0		14 ¹ / ₂		
22	26.0		15 ¹ / ₂		
24	30.0		17 ¹ / ₂		
26	32.0		18 ¹ / ₂		
30	41.0		20 ⁵ / ₈		
32	42.0		21 ⁵ / ₈	8 ³ / ₄	7,300
36	46.0		23 ⁵ / ₈		

*Standard Wall Pipe The above load ratings are applicable to the saddle only and are not applicable to the stanchion or other means used to support the saddle.

- Straps
- Pipe Supports
- Trapeze
- Pipe Shields & Saddles
- Pipe Roll
- Pipe Guides & Slides
- Spring Hangers
- Constant Supports
- Vibration Control & Sway Brace
- Sway Strut Assembly
- Snubbers
- Special Design Products
- Application Examples
- Master Format 3 Part Specs.
- Technical Data
- Index

Fig. 264

Adjustable Pipe Saddle Support

Size Range: 2 1/2" through 36"

Material: Cast iron saddle, locknut nipple and special cast iron reducer, assembled.

Finish: Plain or Galvanized

Service: Stanchion type support where vertical adjustment of **stationary** pipe is required.

Approvals: Complies with Federal Specification A-A-1192A (Type 38), WW-H-171-E (Type 39), ANSI/MSS SP-69 and MSS SP-58 (Type 38).

Installation: Adjustment is obtained by turning the locknut nipple. The lower end of the nipple is staked, upsetting the threads to prevent separation of nipple and coupling during adjustment.

Features:

- Vertical adjustment of approximately 4 1/2"
- Saddle supports a broad range of pipe sizes

Ordering: Specify pipe size to be supported, figure number, name and finish.

Order Separately: Figure 63T Square Cut Threaded End Stanchion. Specify "H" and pipe size to be supported by Figure 264.

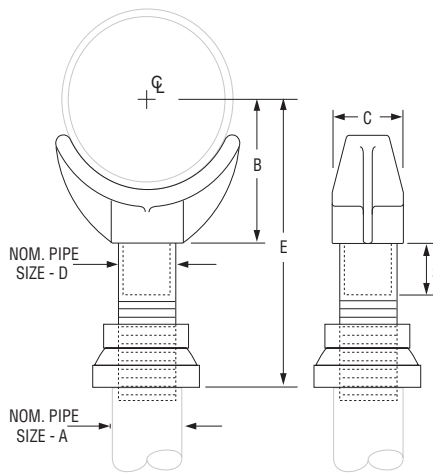
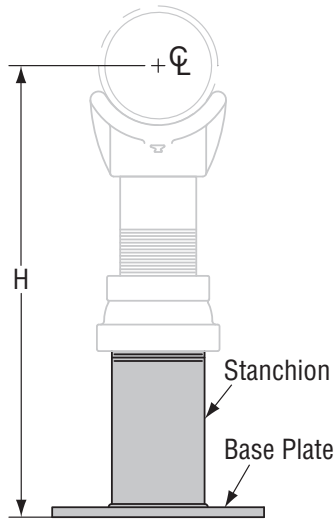

Fig. 63, Type T

Square Cut Threaded End for use with Figure 264 or 265 Adjustable Pipe Saddle Support

FIG. 264: LOADS (LBS) • WEIGHT (LBS) • DIMENSIONS (IN)

Pipe Size	Weight		A	B	D	E		Width C	Max Load
	Complete	Saddle Only				Min	Max		
2 1/2	9.0	4.8	2 1/2	3 1/2	1 1/2	8	13	3	1,800
3	9.2	5.0		3 3/4		8 1/4	13 1/4		
3 1/2	9.4	5.2		4		8 1/2	13 1/2		
4	15.0	7.6	3	4 1/4	2 1/2	9 1/4	14	3 5/8	3,800
5	16.7	8.3		4 7/8		10	14 3/4		
6	17.7	10.3		5 1/2		10 1/2	15 1/4		
8	20.2	12.8		6 7/8		11 3/4	16 1/2		
10	25.2	17.8		8 1/2		13 1/2	18 1/4		
12	29.0	21.6		9 15/16		15	19 3/4		
14	40.2	38.0	4	10 5/16	3	16 3/4	20 3/4	4 5/8	5,300
16	53.2	42.0		12 3/8		17 3/4	22 1/4		
18	70.8	51.0	6	13 7/8	3 1/2	19 1/2	24	6 3/4	6,700
20	104.8	85.0		15 3/8		21	25 1/2		
22	121.0	98.0		15 1/2		21 5/16	25 13/16		
24	137.0	110.0		17 15/16	23 3/4	28 1/4			
26	154.0	130.0		18 1/2	24 5/16	28 13/16			
30	170.0	150.0		21 5/16	27	31 1/2			
32	181.0	161.1	4	22 1/2	4	28 1/4	32 3/4	8 3/4	7,300
36	249.0	229.0		24 1/2		30 1/4	34 3/4		

* The special cast iron reducer may be furnished with a hexed shaped smaller end.

* Standard Wall Pipe

The above load ratings are applicable to the saddle only and are not applicable to the stanchion or other means used to support the saddle.

Fig. 265

Adjustable Pipe Saddle Support with U-Bolt

Size Range: 4" through 36"

Material: Cast iron saddle, steel yoke and nuts, steel locknut nipple and special cast iron reducer. (14" through 36" carbon steel saddle with steel yoke. 4" through 12" steel saddle available upon special request)

Finish: Plain or Galvanized

Service: Stanchion type support where vertical adjustment is required, plus the additional stability provided by U-bolt attachment to pipe.

Approvals: Complies with Federal Specification A-A-1192A (Type 38), WW-H-171-E (Type 39), ANSI/MSS SP-69 and MSS SP-58 (Type 38).

Installation: Adjustment is obtained by turning the locknut nipple. The lower end of the nipple is staked, upsetting the threads to prevent separation of nipple and coupling during adjustment.

Features:

- Vertical adjustment of approximately 4 1/2"
- Saddle supports a broad range of pipe sizes

Ordering: Specify pipe size to be supported, figure number, name and finish.

Order Separately: Figure 63T Square Cut Threaded End Stanchion. Specify "H" and pipe size to be supported by Figure 265.

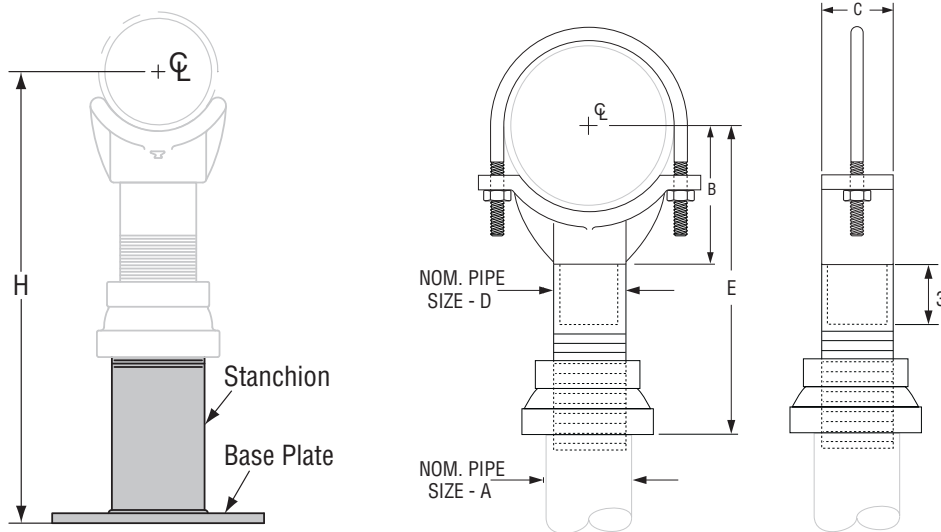
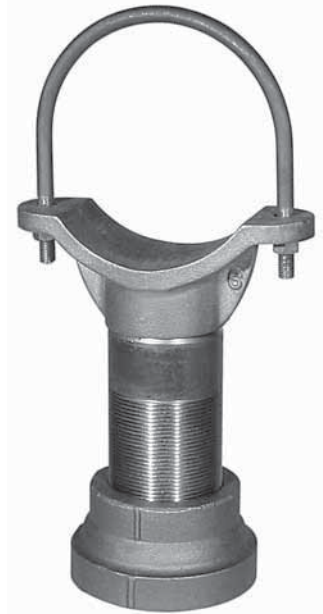

Fig. 63, Type T

Square Cut Threaded End for use with Figure 264 or 265 Adjustable Pipe Saddle Support

FIG. 265: LOADS (LBS) • WEIGHT (LBS) • DIMENSIONS (IN)

Pipe Size	Weight		A	B	D	E		Width C	Max Load
	Complete	Saddle Only				Min	Max		
4	22.0	10.8	4	4 ³ / ₁₆	3	9 ¹ / ₂	14	3 ⁵ / ₈	3,800
5	23.1	12.1		4 ¹³ / ₁₆		10 ¹ / ₈	14 ⁵ / ₈		
6	23.9	12.7		5 ⁷ / ₁₆		10 ³ / ₄	15 ¹ / ₄		
8	32.5	21.3		6 ¹⁵ / ₁₆		12 ¹ / ₄	16 ³ / ₄		
10	36.9	25.7		8 ⁷ / ₁₆		13 ³ / ₄	18 ¹ / ₄		
12	42.4	31.2		9 ¹⁵ / ₁₆		14 ⁵ / ₈	19 ¹ / ₈		
14	39.2	28.0		10 ¹ / ₂		15 ¹³ / ₁₆	20 ⁵ / ₁₆		
16	42.2	31.0	11 ¹ / ₂	16 ¹³ / ₁₆	21 ⁵ / ₁₆	5,300	6	5,300	
18	60.0	40.0	13 ¹ / ₂	19 ⁷ / ₈	23 ³ / ₈				
20	63.0	43.0	6	14 ¹ / ₂	3 ¹ / ₂	20 ¹ / ₈	24 ⁵ / ₈	6	7,300
22	66.0	46.0		15 ¹ / ₂		21 ⁵ / ₁₆	25 ⁵ / ₁₆		
24	72.0	52.0		17 ¹ / ₂		23 ³ / ₁₆	27 ¹³ / ₁₆		
26	75.0	57.0		18 ¹ / ₂		24 ³ / ₁₆	28 ¹³ / ₁₆		
30	89.0	69.0		20 ⁵ / ₈		26 ⁷ / ₁₆	30 ¹⁵ / ₁₆		
32	93.0	73.0	21 ⁵ / ₈	27 ¹ / ₈	31 ¹⁵ / ₁₆	29 ⁷ / ₁₆	33 ¹⁵ / ₁₆	7,300	
36	101.0	81.0	23 ⁵ / ₈	29 ⁷ / ₁₆	33 ¹⁵ / ₁₆				

* The special cast iron reducer may be furnished with a hexed shaped smaller end.

* Standard Wall Pipe

The above load ratings are applicable to the saddle only and are not applicable to the stanchion or other means used to support the saddle.

Fig. 259

Pipe Saddle Support with U-Bolt

Size Range: 4" through 36" pipe

Material: Cast iron stanchion saddle with steel yoke and nuts. 14" through 36" carbon steel saddle with steel yoke. 4" through 12" steel saddle available on special request.

Finish: Plain or Galvanized

Service: Stanchion type support with additional stability provided by U-bolt attachment to pipe.

Approvals: Complies with Federal Specification A-A-1192A (Type 37), ANSI/MSS SP-69 and MSS SP-58 (Type 37).

Installation: Same as pipe saddle support Fig. 258, except that yoke is attached to saddle after pipe is in place.

Features: U-bolt yoke provides stability.

Ordering: Specify pipe size to be supported, figure number, name, material and finish.

Order Separately: Figure 63P Square Cut End Stanchion. Specify "H" and pipe size to be supported by Figure 265.



Fig. 259
Cast Iron

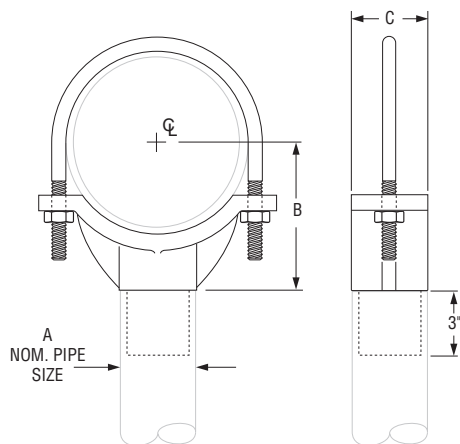

Fig. 259
Cast Iron

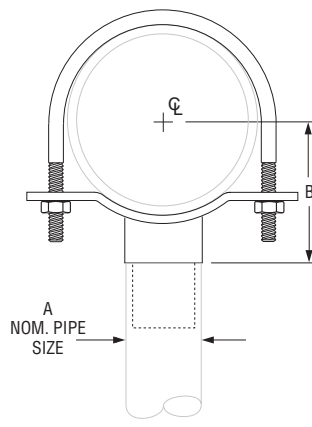

Fig. 259
Fabricated Steel



Fig. 259
Fabricated Steel

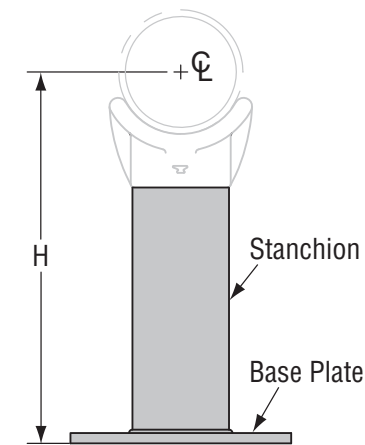

Fig. 63, Type P

Square Cut End for use with Figure 258 or 259 Pipe Saddle Support

FIG. 259: WEIGHTS (LBS) • DIMENSIONS (IN)

Pipe Size	Weight	A	B	Width C	Max Load
4	10.8	3	4 ³ / ₁₆	3 ⁵ / ₈	3,800
5	12.1		4 ¹³ / ₁₆		
6	12.7		5 ⁷ / ₁₆		
8	21.3		6 ¹⁵ / ₁₆		
10	25.7		8 ⁷ / ₁₆		
12	31.2		9 ¹⁵ / ₁₆		
14	28.0	4	10 ¹ / ₂	6	5,300
16	31.0		11 ¹ / ₂		6,700
18	40.0		13 ¹ / ₂	7,300	
20	43.0		14 ¹ / ₂		
22	46.0		15 ¹ / ₂		
24	52.0		17 ¹ / ₂		
26	55.0		18 ¹ / ₂		
30	69.0		20 ³ / ₈		
32	73.0		21 ³ / ₈		
36	81.0		23 ³ / ₈		

* Standard Wall Pipe

The above load ratings are applicable to the saddle only and are not applicable to the stanchion or other means used to support the saddle.

Fig. 46

Universal Trapeze Assembly

Material: Carbon steel

Finish: Plain or Galvanized

Service: Trapeze assembly is to be suspended by two rods with Fig. 60 washer plates and is designed for top loading exclusively.

Ordering: Specify size number, figure number, name, finish, C to C dimension and hole size "H". If holes "J" or hole "D" are required, also specify hole size and dimensions "K" and "M" or "B".

Note: Larger C to C dimensions are available upon request.

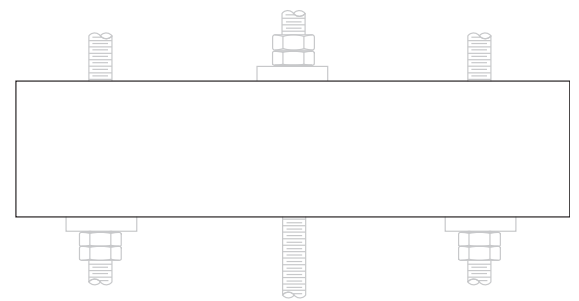
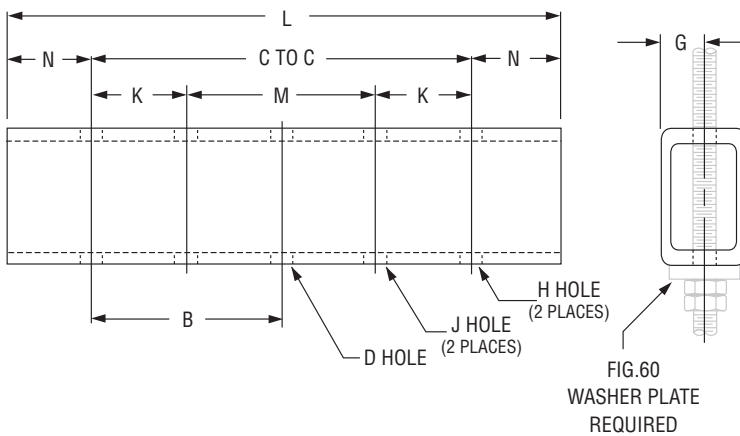
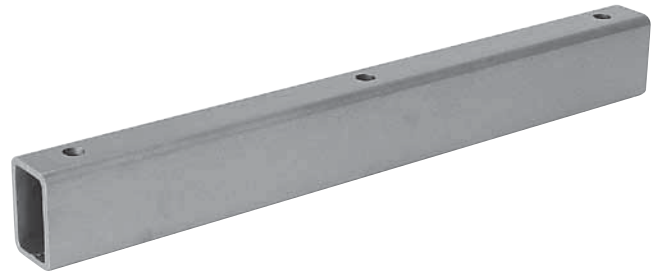

FIG. 46: WEIGHT (LBS) • DIMENSIONS (IN)

Size	Size Tubing	Weight	Max Hole Dia. H, J, D	G	N	C to C = Span (in)														
						12	14	16	18	20	22	24	26	28	30	36	42	48	54	60
						L (in)														
1	1/4 x 2 x 2	5.40	1 1/8	1	1 1/2	15	17	19	21	23	25	27	29	31	33	39	-	-	-	-
2	1/4 x 3 x 2	7.10				-	-	-	23 1/4	25 1/4	27 1/4	29 1/4	31 1/4	33 1/4	35 1/4	41 1/4	47 1/4	53 1/4	59 1/4	65 1/4
3	3/16 x 4 x 3	8.14	1 5/8	1 1/2	2 1/2	-	-	-	23	25	27	29	31	33	35	41	47	53	59	65
4	1/4 x 4 x 4	12.00	1 7/8	2	2 5/8	-	-	-	23 1/4	25 1/4	27 1/4	29 1/4	31 1/4	33 1/4	35 1/4	41 1/4	47 1/4	53 1/4	59 1/4	65 1/4
5	1/4 x 6 x 4	15.42	2 3/8		3 3/8	-	-	-	-	-	-	30 3/4	32 3/4	34 3/4	36 3/4	42 3/4	48 3/4	54 3/4	60 3/4	66 3/4
6	1/4 x 8 x 4	18.80	2 7/8		4	-	-	-	-	-	-	32	34	36	38	44	50	56	62	68

Size	FIG. 46: MAXIMUM LOAD (LBS); BASED ON C TO C DIMENSIONS AT MAX TEMPERATURE OF 250° F															
	12	14	16	18	20	22	24	26	28	30	36	42	48	54	60	
1	2,600	2,300	1,900	1,700	1,500	1,400	1,300	1,200	1,100	1,000	8,80	-	-	-	-	
2	6,700	5,700	5,000	4,500	4,000	3,600	3,300	3,100	2,800	2,700	2,200	-	-	-	-	
3	-	-	-	5,800	5,200	4,800	4,400	3,900	3,600	3,500	2,900	2,500	2,200	1,900	1,700	
4	-	-	-	10,200	9,100	8,300	7,500	7,000	6,500	6,100	5,100	4,300	3,800	3,300	3,000	
5	-	-	-	-	-	-	12,000	11,100	10,300	9,600	8,000	6,800	6,000	5,300	4,800	
6	-	-	-	-	-	-	20,000	18,400	17,100	16,000	13,300	11,400	10,000	8,800	8,000	

Fig. 45

Channel Assembly

Material: Carbon steel

Finish: Plain or Galvanized

Ordering: Fig. 45 channel assembly; channel size, rod size, name, finish and C to C. Note: that $L = (C \text{ to } C) + 2M + W$

Note: Can also be used with a U-bolt Fig. 137 & Fig. 60 washer plates to secure pipe to the center of channel assembly.

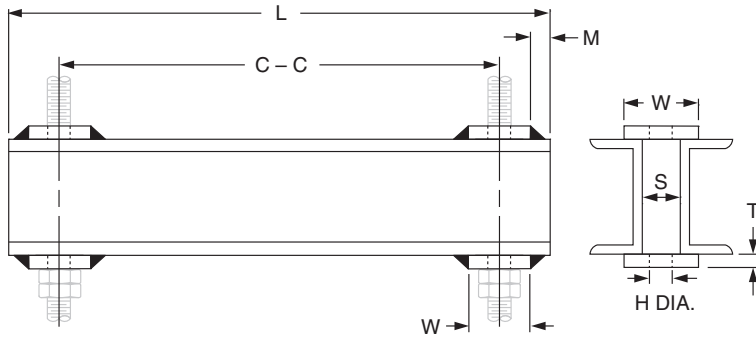
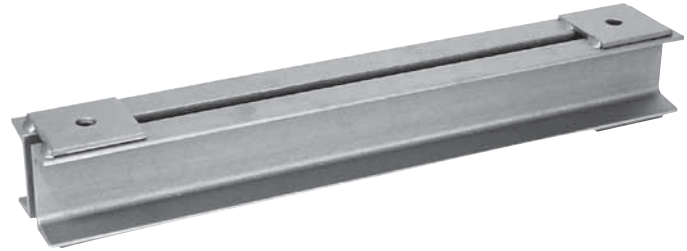

FIG. 45: DIMENSIONS (IN)

Rod Dia	3/8	1/2	5/8	3/4	7/8	1	1 1/4	1 1/2	1 3/4	2	2 1/4	2 1/2	2 3/4	3	3 1/4	3 1/2
H Hole	1/2	5/8	3/4	7/8	1	1 1/4	1 1/2	1 3/4	2	2 1/4	2 1/2	2 3/4	3	3 1/4	3 1/2	3 3/4
S	9/16	1 1/16	1 3/16	1 5/16	1 1/16	1 3/8	1 5/8	1 7/8	2 1/4	2 1/2	2 3/4	3	3 1/4	3 1/2	3 3/4	4
W	3	3	3	4	4	4	5	5	5	5	6	6	6	6	6	7
T	1/4	1/4	3/8	3/8	1/2	1/2	1/2	3/4	3/4	3/4	3/4	3/4	3/4	3/4	3/4	3/4
M	3/8	3/8			3/8	3/8	3/8	3/8	3/8	3/8	3/8	3/8	3/8	3/8	3/8	1/2

FIG. 45: WEIGHTS (LBS) • LOADS (LBS) • C TO C = SPAN (IN)

Size	Wt./Ft. 2C's	Maximum Load (lbs); Based on C to C Dimensions at Max Temperature of 250° F															
		12	14	16	18	20	22	24	26	28	30	36	42	48	54	60	
3	8.2	8,800	7,500	6,600	5,800	5,200	4,800	4,400	3,900	3,600	3,500	2,900	2,500	2,200	1,900	1,700	
4	10.8	15,200	13,100	11,400	10,200	9,100	8,300	7,500	7,000	6,500	6,100	5,100	4,300	3,800	3,300	3,000	
5	13.4	-	-	-	16,000	14,400	13,100	12,000	11,100	10,300	9,600	8,000	6,800	6,000	5,300	4,800	
6	21.0	-	-	-	26,600	24,000	21,800	20,000	18,400	17,100	16,000	13,300	11,400	10,000	8,800	8,000	
8	23.0	-	-	-	-	-	-	32,300	29,800	27,700	25,800	21,500	18,500	16,100	14,300	12,900	
10	30.6	-	-	-	-	-	-	53,500	49,400	45,800	42,800	35,700	30,600	26,700	23,800	21,400	
12	41.4	-	-	-	-	-	-	-	-	-	-	57,000	48,900	42,800	38,000	34,200	
15	67.8	-	-	-	-	-	-	-	-	-	-	111,000	95,300	83,400	74,100	66,700	

Fig. 50

Equal Leg Angle for Trapeze Assembly

Material: Carbon steel
Finish: Plain or Galvanized
Ordering:

If two holes "H" are required:

Specify Fig. 50 angle
 (nominal size, C to C, H, total weight and load)

If two holes "H" and hole "D" are required:

Specify Fig. 50 angle
 (nominal size, B, C to C, D, H, total weight and load)

If two holes "H" and two holes "J" are required:

Specify Fig. 50 angle
 (nominal size, C to C, H, J, K, M, total weight and load)

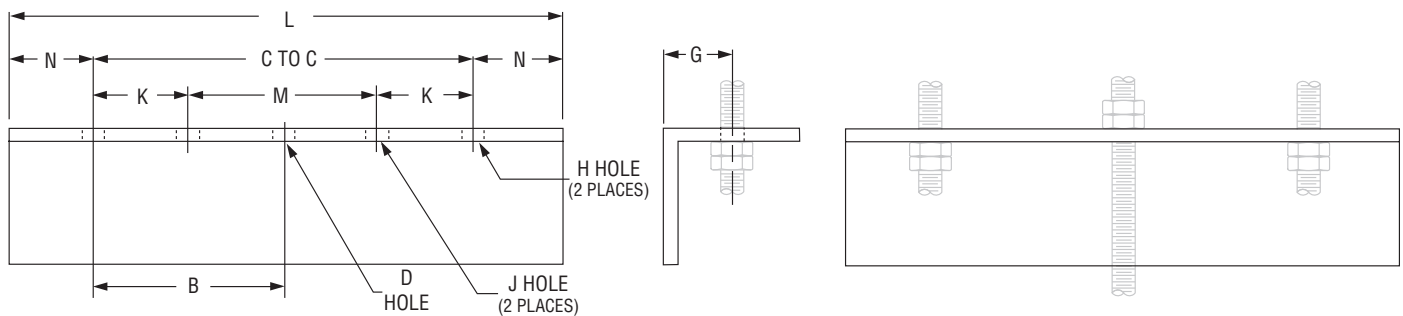

FIG. 50: LOAD (LBS) • WEIGHT (LBS) • DIMENSIONS (IN)

Size	Weight Per/Ft	G	N	Max Rod Size H	C to C = Span in Inches										
					8	10	12	14	16	18	20	22	24	28	30
					Maximum Load; Based on C to C Dimensions at Max Temperature of 250°F										
1½ x ¼	2.34	7/8	1¼	½	780	624	520	446	390	346	312	284	260	223	208
2 x ¼	3.19	1⅝	1½	5/8	1,500	1,200	1,000	856	750	667	600	545	500	428	400
2 x 3/8	4.70			¾	2,100	1,680	1,400	1,200	1,050	933	840	763	700	600	560
2½ x 3/8	5.90	1⅜		1	3,420	2,736	2,280	1,954	1,710	1,520	1,368	1,244	1,140	977	912
3 x 3/8	7.20	1¾	1¾	1¼	4,980	3,984	3,320	2,846	2,490	2,130	1,992	1,810	1,660	1,423	1,328
3 x ½	9.40				6,600	5,280	4,400	3,772	3,300	2,933	2,640	2,400	2,200	1,886	1,760
4 x ½	12.80	2½			2	2	12,000	9,600	8,000	6,858	6,000	5,333	4,800	4,364	4,000

Fig. 167

Insulation Protection Shield

Size Range: 1/2" through 24" pipe with up to 2" thick insulation

Material: Carbon steel

Finish: Galvanized

Service: Recommended for outside of foam or fiber glass insulation for distribution of loads to preclude crushing of insulation without breaking the vapor barrier.

Approvals: Complies with Federal Specification A-A-1192A (Type 40), WW-H-171-E (Type 41), ANSI/MSS SP-69 and MSS SP-58 (Type 40).

How to size: Refer to "shield size selection table" below.

Ordering: Specify size, figure number and name. Data applicable to shields for thicker insulation or larger pipe sizes is available upon request.



SHIELD SIZE SELECTION FOR NOMINAL PIPE SIZE

Pipe Size	Insulation Thickness (in)				
	1/2	3/4	1	1 1/2	2
1/2	1A	1A	—	—	—
3/4		2A	3A	4A	6A
1	2A	3A	4A	6A	7A
1 1/4		4A	5A	7A	8A
1 1/2	3A	4A	5A	7A	8A
2	4A	5A	6A	8A	9A
2 1/2	5A	6A	7A	8A	9A
3	—	—	8A	9A	10A
3 1/2	—	—	8A	9A	10A
4	—	—	9B	10B	11B
5	—	—	10B	11B	12B
6	—	—	12B	13C	14C
8	—	—	14C	15C	16C
10	—	—	16C	17C	18C
12	—	—	17C	18C	19C
14	—	—	19C	20C	21C
16	—	—	21C	22C	23C
18	—	—	23C	24C	25C
20	—	—	26C	27C	28C
24	—	—	26C	27C	28C

SHIELD SIZE SELECTION FOR COPPER TUBING

Tube Size	Insulation Thickness (in)				
	1/2	3/4	1	1 1/2	2
3/8	X1A	1A	2A	3A	5A
1/2, 5/8, 3/4		2A	3A	4A	6A
1, 1 1/4	1A	2A	3A	5A	7A
1 1/2	2A	3A	4A	6A	8A
2	3A	4A	5A	7A	
2 1/2	4A	5A	6A	8A	9A
3	5A	6A	7A		
3 1/2	6A	7A	8A	9A	10A
4	7A	8A		9A	10A
5	8A		9A	10A	11B
6	9A	9A	10A	11B	12B
8	11B	11B	12B	13C	14C

Note: As actual foam or fiber glass insulation thicknesses vary, verify that the radius of the selected shield is suitable for the required application. Shields are designed for a maximum span of ten feet on 15 P.S.I. compressive strength insulation. For compressive strengths greater than 15 P.S.I., spans may be increased proportionately up to maximum allowable for steel pipe. Refer to MSS-SP-69 for specific guidelines on compressive strength and maximum span.

FIG. 167: WEIGHT (LBS) • DIMENSIONS (IN)

Shield Size	Weight	Stock Size	L	Insulation OD	Fig. 260
X1A	0.5	18 Ga.	12	1.90	1 1/2
1A	0.7			2.38	2
2A	0.8			2.88	2 1/2
3A	1.0			3.50	3
4A	1.1			4.00	3 1/2
5A	1.3			4.50	4
6A	1.4			5.00	5
7A	1.6			5.56	5
8A	1.9			6.64	6
9A	2.7			7.64	8
10A	3.1	16 Ga.	18	8.64	8
9B	4.0			7.64	8
10B	4.6			8.64	8
11B	5.1	16 Ga.	18	9.64	10
12B	5.6			10.76	10
13C	10.2	14 Ga.	24	11.76	12
14C	11.1			12.76	12
15C	12.3			14.00	14
16C	12.7			15.00	16
17C	13.6			16.00	16
18C	14.5			17.00	18
19C	21.2			18.00	18
20C	22.4			19.00	20
21C	23.6			20.00	20
22C	24.8			12 Ga.	24
23C	25.9	22.00	24		
24C	27.1	23.00	24		
25C	28.3	24.00	24		
26C	31.0	26.00	30		
27C	31.8	27.00	30		
28C	33.0			28.00	30

Shading in gray indicates this shield fits loosely inside the Fig. 260. To be used properly, the Fig. 260 requires a spacer.

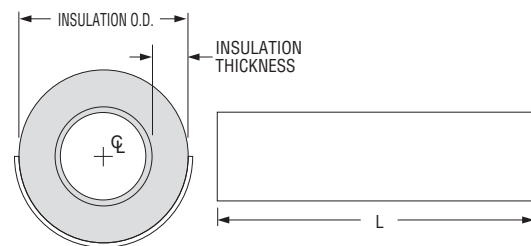

Fig. 168

Rib-Lok Shield

Size Range: 1/2" through 8" pipe or copper tube with up to 2" insulation

Material: Carbon steel

Finish: Galvanized

Approvals: Complies with Federal Specification A-A-1192A (Type 40), WW-H-171-E (Type 41), ANSI/MSS SP-69 and MSS SP-58 (Type 40).

Service: To be used with Fig. 65 or Fig. 260 clevis. Designed to prevent damage to insulation by hanger. Ribs keep shield centered in hanger.

How to size: Refer to shield size selection table below.

Ordering: Specify size, figure number and name.

Note: Data applicable to shields for thicker insulation or larger pipe size is available upon request.



SHIELD SIZE SELECTION FOR NOMINAL PIPE SIZE

Pipe Size	Insulation Thickness (in)				
	1/2	3/4	1	1 1/2	2
1/2	1	1	-	-	-
3/4			2	4	6
1	2	3	3	5	7
1 1/4			4	6	
1 1/2	3	4	5	7	8
2			6		
2 1/2	4	5	6	8	9
3	5	6	7		
3 1/2	-	-	8	9	10
4			9	10	11
5			10	11	12
6			11	12	13
8			12	13	14

SHIELD SIZE SELECTION FOR COPPER TUBING

Tube Size	Insulation Thickness (in)				
	1/2	3/4	1	1 1/2	2
3/8	-	1	2	3	5
1/2, 5/8		1	2	4	6
1	1	2	3	5	7
1 1/4					
1 1/2	2	3	4	7	8
2	3	4	5		
2 1/2	4	5	6	8	9
3	5	6	7		
3 1/2	6	7	8	9	10
4	7				
5	8	8	9	10	11
6	9	9	10	11	12
8	11	11	12	13	14

FIG. 168: WEIGHT (LBS) • DIMENSIONS (IN)

Shield Size	Max O.D. of Insulation	Stock Sizes	Weight	Fig. 260
1	2 3/8	18 ga. x 8	0.41	2
2	2 7/8		0.50	2 1/2
3	3 1/2		0.61	3
4	4		0.69	3 1/2
5	4 1/2		0.78	4
6	5		0.99	5
7	5 5/8		1.09	5
8	6 5/8		1.28	6
9	7 5/8	18 ga. x 12	1.51	8
10	8 5/8		2.24	8
11	9 5/8		2.48	10
12	10 3/4		2.76	10
13	11 3/4		3.03	12
14	12 3/4		3.28	12

Shading in gray indicates this shield fits loosely inside the Fig. 260. To be used properly, the Fig. 260 requires a spacer.

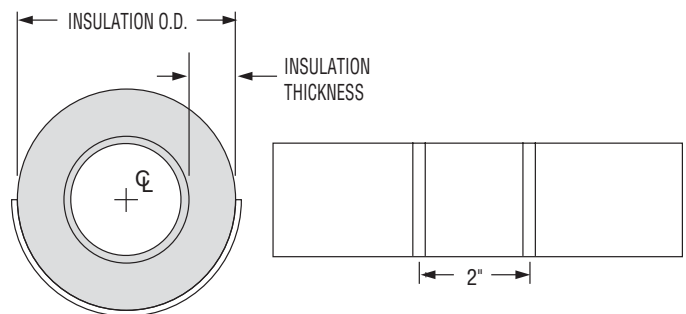

Pipe Covering Protection Saddle For Nominal Thickness of Covering Shown

Fig. 160: 1"

Fig. 163: 2½"

Fig. 165A: 4" (Alloy)

Fig. 161: 1½"

Fig. 164: 3"

Fig. 166A: 5½" (Alloy)

Fig. 162: 2"

Fig. 165: 4"

Size Range: ¾" through 36"

Material:

- Figs. 160, 161, 162, 163, 164, and 165 are curved carbon steel plate.
- Figs. 165A and 166A are alloy steel manufactured from ASTM A 387 Grade 22 Chrome Molybdenum steel plate.
- Figs. 165A and 166A have a welded-in center plate in all sizes.
- All other saddles have a welded-in center plate for pipe sizes 12" and larger.
- All saddles are 12" long with side edges turned up.

Finish: Plain

Service: Designed for use on insulated high temperature systems where heat losses are to be kept to a minimum and to protect insulation against damage.

Maximum Temperature: 650° F carbon steel, 950° F alloy steel.

Approvals: Complies with Federal Specification A-A-1192A (Type 39A & 39B), WW-H-171-E (Type 40A & 40B), ANSI/MSS SP-69 and MSS SP-58 (Type 39A & 39B).

Features: Permits finished, weather tight covering at all points of pipe support.

Ordering: Specify pipe size, figure number and name. Data for 42" size available on request.

Installation: It is recommended that saddle be welded to the pipe.

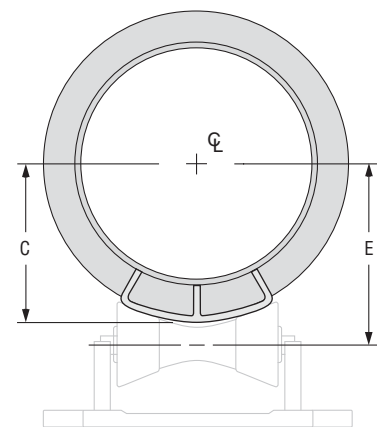
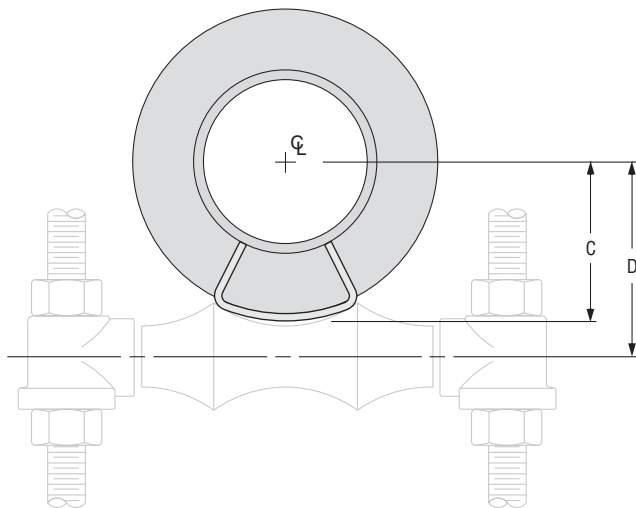
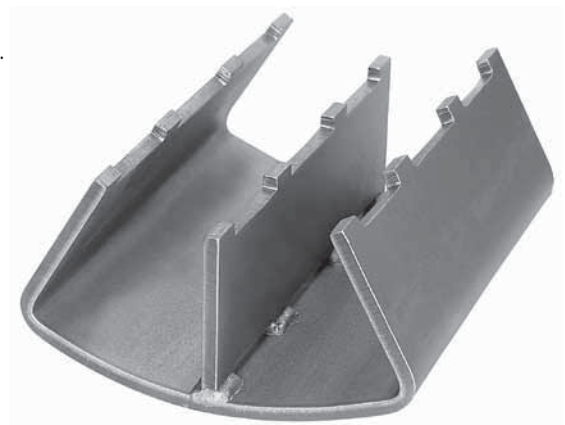

Continued on Following Page.

Fig. 160 to Fig 166A

Pipe Covering Protection Saddle (cont.)

FIG. 160, 161, 162, 163, 164, 165, 165A, 166A: LOADS (LBS) • WEIGHT (LBS) • DIMENSIONS (IN)										
Pipe Size	Fig. No.	Max Load ■	Weight	Size of Pipe Roll			Center Line of Pipe to Outside of Saddle C	Center Line of Pipe to Center Line of Roll		
				Figs. 171, 175, 177	Figs. 174, 181	Figs. 271, 274, 277		D		E
								Figs. 171, 175, 177	Figs. 174, 181	
¾	160•	1,200	1.4	2	2½	2-3½	1⅝	2¼	2½	2¼
	161•		2.1	3	3½		2⅜	2¾	2¾	2⅞
	162•		2.8	4	5		2⅞	3⅞	3⅞	3⅞
1	160•	1,200	1.4	2½	3	2-3½	1⅜	2⅞	2¼	2⅞
	161•		2.1	3	4		2⅞	2⅞	2⅞	3
	162•		2.8	4	5		3	3½	3½	3½
1¼	160	1,200	1.4	2½	3	2-3½	1⅝	2½	2⅞	2⅞
	161•		2.1	3½	5		2⅞	3⅞	3⅞	3⅞
	162•		2.8	4			3	3⅞	3⅞	3⅞
	163•		3.6	5	6	4-6	3¾	4⅞	4⅞	4⅞
1½	160	1,200	1.5	3	3½	2-3½	2⅞	2⅞	2⅞	2⅞
	161•		2.1	3½	5		2⅞	3¼	3¼	3⅞
	162•		3.2	5	6	4-6	3⅞	4	4	3⅞
	163•		3.6	6	8		3⅞	4½	4⅞	4½
2	160	1,200	1.7	3½	4	2-3½	2⅞	3	2⅞	3⅞
	161•		2.3	4	5		2⅞	3½	3½	3⅞
	162•		3.2	5	6	4-6	3⅞	4¼	4¼	4⅞
	163•		3.6	6	8		4⅞	4¾	4⅞	4¾
	164•		4.5	8			4⅞	5⅞	5⅞	5¼
2½	160	1,200	1.7	3½	5	2-3½	2⅞	3¼	3¼	3⅞
	161		2.8	5	6		3⅞	4	4	3⅞
	162		3.2	6	8	4-6	3⅞	4½	4⅞	4½
	163		4.1	8			4¼	5⅞	5⅞	5
	164		4.5				10	4⅞	5⅞	5¼
3	160	1,200	1.9	4	5	2-3½	2⅞	3½	3½	3⅞
	161		2.8	5	6		3⅞	4⅞	4⅞	4¼
	162		3.6	6	8	4-6	4⅞	4⅞	4⅞	4⅞
	163		4.1	8			4⅞	5⅞	5⅞	5⅞
	164		4.9				10	8-10	5⅞	6
3½	160	1,200	2.3	5	6	4-6	3⅞	4	4	3⅞
	161		3.2	6	8		3⅞	4⅞	4⅞	4½
	162		3.6	8		4⅞	5⅞	5⅞	5	
	163		4.5			10	4⅞	5⅞	5⅞	5⅞
	164		4.9	10	8-10		5⅞	6⅞	6⅞	6⅞
4	160	1,200	2.3	5	6	4-6	3⅞	4¼	4¼	4⅞
	161		3.2	6	8		4⅞	4⅞	4⅞	4¾
	162		3.6	8			4⅞	5⅞	5⅞	5¼
	163		4.5		10	10	5	5⅞	5⅞	6
	164		4.9	10			12	5⅞	6⅞	6⅞
	165		6.1		10	12		6½	7⅞	7⅞
	165A	11.6	7,200	12			12-14	6½	7⅞	7⅞
166A	15.7	14			16	8⅞				

- Maximum recommended loads are applicable only when saddle is used on a flat bearing surface or roller hangers and tack welded to pipe. When saddle is used with a pipe roll, the maximum load for the assembly is the smaller of the two loads.
- Saddles may require notching when used with a U-bolt.

Continued on Following Page.

PIPE SHIELDS & SADDLES

Fig. 160 to Fig 166A Pipe Covering Protection Saddle (cont.)

FIG. 160, 161, 162, 163, 164, 165, 165A, 166A: LOADS (LBS) • WEIGHT (LBS) • DIMENSIONS (IN)										
Pipe Size	Fig. No.	Max Load ■	Weight	Size of Pipe Roll			Center Line of Pipe to Outside of Saddle C	Center Line of Pipe to Center Line of Roll		
				Figs. 171, 175, 177	Figs. 174, 181	Figs. 271, 274, 277		D		E
								Figs. 171, 175, 177	Figs. 174, 181	Figs. 271, 274, 277
5	160	1,200	2.3	6	8	4-6	4 ¹ / ₈	4 ¹³ / ₁₆	4 ¹³ / ₁₆	4 ³ / ₄
	161		3.2	8			4 ¹¹ / ₁₆	5 ¹ / ₂	5 ¹ / ₂	5 ³ / ₈
	162		3.6	10	8-10	5 ³ / ₁₆	6	6 ¹ / ₁₆	6 ¹ / ₈	
	163		4.5			5 ⁵ / ₈	6 ⁹ / ₁₆	6 ⁹ / ₁₆	6 ⁵ / ₈	
	164		4.9	12	6 ³ / ₁₆	7 ¹ / ₈	7 ¹ / ₄	7 ¹ / ₄		
	165		6.1	12	14	12-14	7 ¹ / ₈	8 ³ / ₁₆	8 ³ / ₈	8 ³ / ₁₆
	165A	11.6	8 ¹ / ₈	8 ³ / ₈	8 ³ / ₁₆					
	166A	7,200	15.7	16	16	8 ¹ / ₁₆	10 ¹ / ₁₆	10 ¹ / ₁₆	9 ⁷ / ₈	
6	160	1,800	3.8	8	8	4-6	4 ¹ / ₂	5 ³ / ₈	5 ³ / ₈	5 ¹ / ₄
	161		4.4				10	8-10	5 ¹ / ₁₆	5 ⁷ / ₈
	162		5.7	10	8-10	5 ¹ / ₂	6 ⁷ / ₁₆	6 ⁷ / ₁₆	6 ¹ / ₂	
	163		6.5			12	6 ³ / ₁₆	7 ¹ / ₈	7 ³ / ₁₆	7 ¹ / ₄
	164		7.7	12	12	6 ⁹ / ₁₆	7 ⁵ / ₈	7 ⁵ / ₈	7 ⁵ / ₈	
	165		10.2	14	16	12-14	7 ⁹ / ₁₆	9	9	8 ³ / ₄
	165A	7,200	12.9	14	16	7 ⁵ / ₈	9 ¹ / ₈	9	8 ¹³ / ₁₆	
	166A	16.3	16	18	16-20	9 ¹ / ₈	10 ⁵ / ₈	10 ⁹ / ₁₆	10 ⁷ / ₁₆	
8	161	1,800	5.8	10	12	8-10	6	7 ¹ / ₁₆	7 ¹ / ₁₆	7 ¹ / ₁₆
	162		6.3				6 ¹ / ₂	7 ⁹ / ₁₆	7 ⁹ / ₁₆	7 ⁹ / ₁₆
	163		7.2	12	14	7 ¹ / ₄	8 ⁵ / ₁₆	8 ¹ / ₂	8 ⁵ / ₁₆	
	164		7.7	14	16	12-14	7 ¹¹ / ₁₆	9	9	8 ³ / ₄
	165		10.2	16	18	16-20	8 ¹ / ₁₆	10 ¹ / ₈	10 ¹ / ₈	9 ⁷ / ₈
	165A	7,200	16.9	18	10 ¹ / ₄		10 ¹ / ₁₆	11 ¹³ / ₁₆	11 ⁵ / ₈	
	166A	22.6	18	20	10 ³ / ₄	11 ⁷ / ₈	11 ¹³ / ₁₆	11 ⁵ / ₈		
10	161	1,800	5.8	12	14	8-10	7 ¹ / ₄	8 ⁵ / ₁₆	8 ¹ / ₂	8 ⁵ / ₁₆
	162		7.7	14	16	12-14	7 ⁵ / ₈	9 ¹ / ₁₆	9	8 ¹³ / ₁₆
	163		8.2				8 ¹ / ₈	9 ⁹ / ₁₆	9 ⁹ / ₁₆	9 ⁵ / ₁₆
	164		8.8	16	18	8 ¹ / ₁₆	10 ¹ / ₈	10 ¹ / ₁₆	10	
	165		10.8	18	20	16-20	9 ³ / ₄	11 ¹ / ₄	11 ¹ / ₄	11 ¹ / ₈
	165A	7,200	18.9				9 ¹ / ₁₆	11 ⁵ / ₁₆	11 ⁵ / ₁₆	11 ⁵ / ₁₆
	166A	24.3	20	—	22-24	11 ¹ / ₈	12 ¹⁵ / ₁₆	—	12 ¹ / ₂	
12	161	5,000	7.8	14	16	12-14	8 ¹ / ₁₆	9 ¹ / ₂	9 ¹ / ₂	9 ¹ / ₄
	162		9.9	16	18	16-20	8 ⁵ / ₈	10 ³ / ₁₆	10 ¹ / ₁₆	10
	163		10.5				9 ¹ / ₈	10 ¹ / ₁₆	10 ⁹ / ₁₆	10 ⁹ / ₁₆
	164		11.4	18	20	9 ⁵ / ₈	11 ¹ / ₈	11 ¹ / ₈	11	
	165		14.0	20	—	16-20	10 ¹³ / ₁₆	12 ³ / ₈	—	12 ³ / ₁₆
	165A		7,200				28.0	11	12 ¹ / ₂	—
	166A	35.5	24	—	22-24	12 ⁵ / ₁₆	14 ¹ / ₄	—	13 ¹¹ / ₁₆	
	14	161	5,000	7.8	16	18	12-14	8 ³ / ₄	10 ³ / ₁₆	10 ¹ / ₈
162		9.9		9 ⁵ / ₁₆			10 ⁷ / ₈	10 ¹³ / ₁₆	10 ¹¹ / ₁₆	
163		10.5		18	20	16-20	9 ⁷ / ₈	11 ⁵ / ₁₆	11 ³ / ₈	11 ³ / ₁₆
164		11.4					10 ⁹ / ₁₆	11 ³ / ₄	11 ³ / ₄	11 ⁵ / ₈
165		14.0		20	—	16-20	11 ⁵ / ₁₆	12 ⁷ / ₈	—	12 ² / ₈
165A		7,200					27.6	11 ⁹ / ₁₆	13 ¹ / ₁₆	—
166A		35.5	24	—	22-24	12 ⁷ / ₈	14 ³ / ₄	—	14 ¹ / ₄	

- Maximum recommended loads are applicable only when saddle is used on a flat bearing surface or roller hangers and tack welded to pipe. When saddle is used with a pipe roll, the maximum load for the assembly is the smaller of the two loads.
- Saddles may require notching when used with a U-bolt.

Continued on Following Page.

Fig. 160 to Fig 166A Pipe Covering Protection Saddle (cont.)

FIG. 160, 161, 162, 163, 164, 165, 165A, 166A: LOADS (LBS) • WEIGHT (LBS) • DIMENSIONS (IN)											
Pipe Size	Fig. No.	Max Load ■	Weight	Size of Pipe Roll			Center Line of Pipe to Outside of Saddle C	Center Line of Pipe to Center Line of Roll			
				Figs. 171, 175, 177	Figs. 174, 181	Figs. 271, 274, 277		D		E	
								Figs. 171, 175, 177	Figs. 174, 181	Figs. 271, 274, 277	Figs. 271, 274, 277
16	161	5,000	8.4	18	20	16-20	9 ³ / ₁₆	11 ¹ / ₄	11 ¹ / ₄	11 ¹ / ₈	
	162		10.4				10 ³ / ₁₆	11 ³ / ₁₆	11 ³ / ₄	11 ⁹ / ₁₆	
	163	7,200	11.1	20	-	-	10 ¹³ / ₁₆	12 ⁵ / ₁₆	-	12 ³ / ₁₆	
	164		13.3				11 ¹ / ₁₆	12 ⁷ / ₈	-	12 ⁷ / ₁₆	
	165		15.3				12 ³ / ₁₆	14 ¹ / ₈	-	13 ⁵ / ₈	
	165A	11,140	30.1	24	-	22-24	12 ⁷ / ₁₆	14 ⁵ / ₁₆	-	13 ³ / ₈	
	166A		40.0				13 ¹³ / ₁₆	16 ⁵ / ₈	-	15 ⁵ / ₈	
18	161	5,000	9.1	20	-	16-20	10 ¹³ / ₁₆	12 ⁵ / ₁₆	-	12 ³ / ₁₆	
	162		10.4				11 ⁵ / ₁₆	12 ⁷ / ₈	-	12 ¹¹ / ₁₆	
	163	7,200	12.4	24	-	22-24	11 ⁵ / ₈	13 ⁹ / ₁₆	-	13 ¹ / ₁₆	
	164		13.3				12 ¹ / ₄	14 ³ / ₁₆	-	13 ⁵ / ₈	
	165		15.3				13 ⁵ / ₁₆	15 ¹ / ₄	-	14 ³ / ₄	
	165A	13,370	40.3	30	-	26-30	13 ³ / ₄	15 ¹ / ₁₆	-	15 ¹ / ₈	
	166A		52.1				14 ⁷ / ₈	17 ⁵ / ₈	-	16 ⁵ / ₈	
20	161	7,200	10.4	24	-	22-24	11 ⁵ / ₈	13 ⁹ / ₁₆	-	13 ¹ / ₁₆	
	162		11.6				12 ¹ / ₄	14 ¹ / ₈	-	13 ⁵ / ₈	
	163		12.4				12 ³ / ₄	14 ¹ / ₁₆	-	14 ³ / ₁₆	
	164		13.4				13 ⁵ / ₁₆	15 ¹ / ₄	-	14 ³ / ₄	
	165	22.8	30	-	26-30	14 ¹ / ₈	17	-	15 ⁵ / ₈		
	165A	44.8				14 ³ / ₈	17 ³ / ₁₆	-	16 ¹ / ₈		
	166A	52.1				16 ¹ / ₈	18 ⁵ / ₁₆	-	17 ⁷ / ₈		
24	161	7,200	12.3	30	-	26-30	13 ¹ / ₂	16 ⁵ / ₁₆	-	15 ¹ / ₄	
	162		13.4				14	16 ⁷ / ₈	-	15 ³ / ₄	
	163		14.3				14 ⁵ / ₈	17 ¹ / ₂	-	16 ⁷ / ₁₆	
	164		20.3				15 ¹ / ₄	18 ¹ / ₁₆	-	17	
	165		23.1				16 ⁷ / ₁₆	19 ¹ / ₄	-	18 ³ / ₁₆	
	165A	13,370	45.4	-	-	16 ¹ / ₁₆	19 ¹ / ₂	-	18 ⁷ / ₁₆		
	166A		52.1			18	-	-	19 ³ / ₄		
30	161	7,200	13.3	-	-	36-42	16 ¹⁵ / ₁₆	-	-	18 ⁷ / ₈	
	162		14.0				17 ¹ / ₂	-	-	19 ³ / ₈	
	163		20.0				18 ¹ / ₁₆	-	-	19 ¹⁵ / ₁₆	
	164		21.4				18 ⁵ / ₈	-	-	20 ¹ / ₂	
	165		24.0				19 ¹¹ / ₁₆	-	-	21 ¹ / ₂	
	165A	13,370	47.9	-	-	19 ¹⁵ / ₁₆	-	-	21 ³ / ₄		
	166A		55.6			21 ¹ / ₂	-	-	23 ³ / ₈		
36	161	7,200	18.0	-	-	36-42	20 ¹ / ₄	-	-	22 ¹ / ₈	
	162		18.9				20 ¹⁵ / ₁₆	-	-	22 ⁵ / ₈	
	163		20.2				21 ⁵ / ₁₆	-	-	23 ³ / ₁₆	
	164		21.6				21 ⁷ / ₈	-	-	23 ¹ / ₁₆	
	165		24.1				22 ⁷ / ₈	-	-	24 ¹ / ₁₆	
	165A	13,370	48.3	-	-	23 ³ / ₈	-	-	25		
	166A		55.8			24 ⁵ / ₈	-	-	26 ¹ / ₂		

- Maximum recommended loads are applicable only when saddle is used on a flat bearing surface or roller hangers and tack welded to pipe. When saddle is used with a pipe roll, the maximum load for the assembly is the smaller of the two loads.
- Saddles may require notching when used with a U-bolt.

Straps
 Pipe Supports
 Trapeze
 Pipe Shields & Saddles
 Pipe Roll
 Pipe Guides & Slides
 Spring Hangers
 Constant Supports
 Vibration Control & Sway Brace
 Sway Strut Assembly
 Snubbers
 Special Design Products
 Application Examples
 Master Format 3 Part Specs.
 Technical Data
 Index

Fig. 177

Adjustable Pipe Roll Support

Size Range: 1" through 30"

Material: Cast iron roll and sockets; steel roll rod, continuous thread rods and hex nuts

Finish: Plain, Galvanized or Resilient Coated

Service: For support of pipe where longitudinal movement due to expansion and contraction will occur and where vertical adjustment up to 6" may be necessary.

Maximum Temperature: 450° F at roller, 300° F at Resilient coated roller.

Approvals: Complies with Federal Specification A-A-1192A (Type 41), WW-H-171-E (Type 42), ANSI/MSS SP-69 and MSS SP-58 (Type 41).

Installation: Normally used directly above steel beams, brackets angles, etc.

Features: Advantages of pipe rollers with a protective resilient coated covering.

- Non conductive pipe rollers - prevent the passing of current from pipeline to structure.
- Corrosion resistant - for protection against severe weather conditions, moderate corrosive conditions such as marine atmospheres and weather resistant to ultra-violet radiation.
- Low coefficient of friction between pipe and resilient coated pipe roller.

How to size:

- (1) If roll is to support bare pipe, select the size directly from nominal pipe size (see below).
- (2) If used with pipe covering protection saddle, see page 118 for size of pipe roll.
- (3) If roll is to support covered pipe, the O.D. of the covering should not be greater than the O.D. of the pipe for which the roll was designed.

Ordering: Specify size of roll, figure number and name. Be certain to order oversized rolls when insulation and protection saddles makes this necessary.

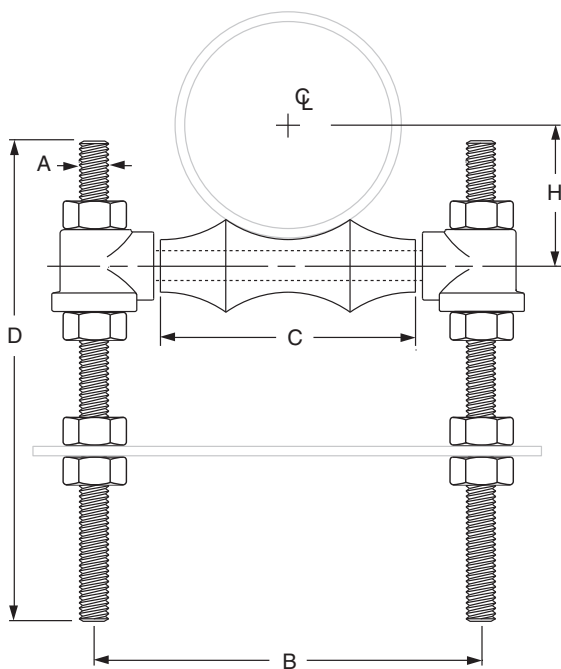
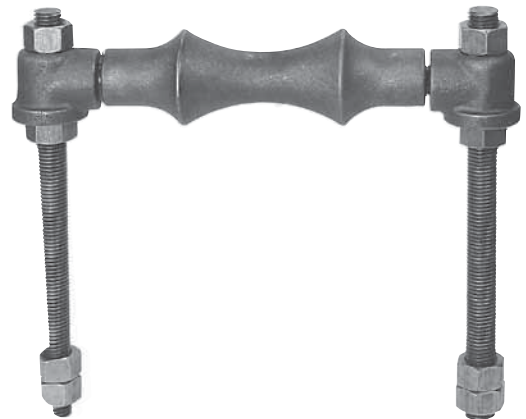

FIG. 177: WEIGHT (LBS) • DIMENSIONS (IN)

Pipe Size	Weight	A	B	C	D	H
1	1.1	3/8	3	1 1/2	12	1 1/16
1 1/4	1.2		3 3/8	1 7/8		1 1/4
1 1/2	1.2		3 5/8	2 1/8		1 3/8
2	1.3	4 1/8	2 5/8	1 5/8		
2 1/2	2.3	4 7/8	3 3/8	1 15/16		
3	2.4	5 1/2	3 3/4	2 1/4		
3 1/2	2.7	1/2	6 1/8	4 1/4	2 9/16	
4	3.8		6 7/8	4 3/4	2 13/16	
5	4.7	5/8	8 1/16	5 13/16	3 7/16	
6	7.6	3/4	9 1/16	6 7/8	4	
8	11.0		11 15/16	8 7/8	5 1/8	
10	13.7	7/8	14 1/16	11	6 3/8	
12	19.4	1	15 3/16	12 1/2	7 7/16	
14	31.2		17 3/4	14 1/4	8 3/8	
16	42.5		19 3/4	16 1/4	9 7/16	
18	46.6	1 1/4	21 7/8	18 1/4	10 1/2	
20	66.2		24 1/4	20 1/4	11 5/8	
24	102.5	1 1/2	28 7/8	24 1/4	14	
30	186.8		35 1/2	30 1/4	17 7/16	

DI/CI ROLL SIZING

DI/CI Pipe Size	Fig. 177 Roller Size
3	4
4	5
6	6
8	8
10	10
12	14
14	16
16	18
18	20
20	24
24	30
30	No Recom.

Fig. 171: Pipe Roll

Single Pipe Roll

Size Range: 1" through 30"

Material: Cast iron roll and sockets, steel roll rod

Finish: Plain, Galvanized or Resilient Coated

Service: For suspension of pipe from two rods where longitudinal expansion and contraction may occur.

Approvals: Complies with Federal Specification A-A-1192A (Type 41), WW-H-171-E (Type 42), ANSI/MSS SP-69 and MSS SP-58 (Type 41).

Adjustment: Adjustable socket permits vertical adjustment at the roll.

Maximum Temperature: 450° F at roller, 300° F at resilient coated roller.

How to size:

- (1) If the roll is to support non-insulated pipe, select the size directly from nominal pipe size (column 1) in table below.
- (2) If used with pipe covering protection saddle, see page 118 for size of pipe roll.

Features:

- Provides for vertical adjustment; nut at bottom of hanger rod fits into the socket preventing loosening or turning due to vibration.
- Pipe roll is designed for two point surface contact with pipe or saddle.

Features: Advantages of pipe rollers with a protective resilient coated covering.

- Non conductive pipe rollers - prevent the passing of current from pipeline to structure.
- Corrosion resistant - for protection against severe weather conditions, moderate corrosive conditions such as marine atmospheres and weather resistant to ultra-violet radiation.
- Low coefficient of friction between pipe and resilient coated pipe roller.

Ordering:

- Specify pipe roll size.
- Order should include figure number, name and finish in all cases. Hanger rods and nuts to be ordered separately.
- Be certain to order oversized rolls when insulation and protection saddles makes this necessary.

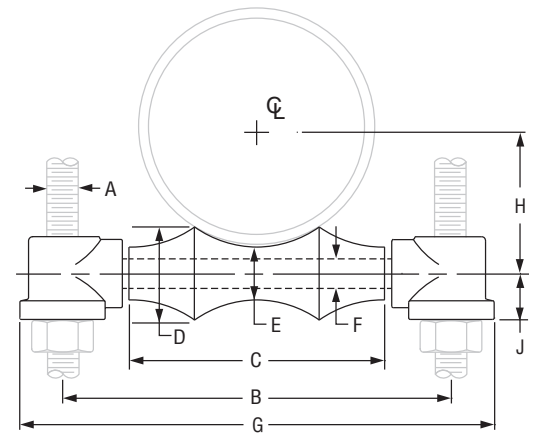

FIG. 171: LOADS (LBS) • WEIGHT (LBS) • DIMENSIONS (IN)

Pipe Size	Max O.D. Covering	Rod Size A	Max Load	Weight	G	B	C	D	E	F	H	J
1	2	3/8	600	0.45	4 1/8	3	1 1/2	1	3/4	3/8	1 1/16	9/16
1 1/4	2 1/2			0.48	4 1/2	3 3/8	1 7/8	1 1/16			1 1/4	
1 1/2	2 3/4			0.51	4 3/4	3 5/8	2 1/8	1 1/8			1 3/8	
2	3 1/4			0.57	5 1/4	4 1/8	2 5/8	1 3/16			1 5/8	
2 1/2	3 3/4	1/2	660	1.00	6 1/4	4 7/8	3 3/8	1 3/8	7/8	1/2	1 15/16	1 1/16
3	4 1/2		700	1.10	6 7/8	5 1/2	3 3/4	1 7/16			2 1/4	
3 1/2	5	5/8	750	1.40	7 1/2	6 1/8	4 1/4	1 5/8	1	1/2	2 9/16	3/4
4	5 1/2			1.70	8 1/4	6 7/8	4 3/4	1 3/4			2 13/16	
5	7			2.60	9 11/16	8 1/16	5 13/16	2			1 1/8	
6	8 1/4	3/4	1,070	4.50	11 7/16	9 9/16	6 7/8	2 5/16	1 1/4	3/4	4	1
8	10 1/2		1,350	7.20	14 1/16	11 15/16	8 7/8	2 13/16	1 1/2	7/8	5 5/8	1 1/8
10	12 3/4	7/8	1,730	9.50	16 3/16	14 1/16	11	3 3/8	1 3/4	1	6 3/8	1 1/8
12	14 3/4		2,400	15.90	17 15/16	15 13/16	12 1/2	3 7/8	2	1	7 7/16	1 1/4
14	16 1/4	1	3,130	24.30	20 7/8	17 3/4	14 1/4	4 5/8	2 1/2	1 1/8	8 3/8	1 3/8
16	18		3,970	31.90	22 7/8	19 3/4	16 1/4	5	2 5/8	1 1/4	9 7/16	1 1/2
18	20 1/4	1 1/4	4,200	35.50	24 1/2	21 7/8	18 1/4	5 7/16	2 3/4	1 1/4	10 1/2	1 1/2
20	22 1/2		4,550	47.00	27 1/4	24 1/4	20 1/4	6	3	1 1/2	11 5/8	1 5/8
24	26 1/2	1 1/2	6,160	76.30	32 7/8	28 7/8	24 1/4	7 3/16	3 5/8	1 1/2	14	1 3/4
30	32 1/2		7,290	129.90	39	35 1/2	30 3/4	8 15/16	4 1/2	1 3/4	17 7/16	2 7/16

DI/CI ROLL SIZING	
DI/CI Pipe Size	Fig. 171 Roller Size
3	4
4	5
6	6
8	8
10	10
12	14
14	16
16	18
18	20
20	24
24	30
30	No Recom.

Fig. 178

Spring Cushion Hanger

Material: Spring cushion hanger Fig. 178 consists of a set of two springs and four cast iron retainers only.

Finish: Plain (retainers), Painted (springs)

Service: Generally used with Fig. 171 single pipe roll as shown in above photo. Recommended for installations where formal load and movement calculations are not required, or calculated movement does not exceed 1/4".

Maximum Temperature: 450° F at roller

Approvals: Complies with Federal Specification A-A-1192A (Type 49), WW-H-171-E (Type 50), ANSI/MSS SP-69 and MSS SP-58 (Type 49).

Ordering: Specify figure number, name and rod size. If used with Fig. 171 single pipe roll, pipe roll must be ordered separately. The retainers are casted to the dimensions as shown, but center hole can be drilled or reamed larger to satisfy the hanger rod required, up to the max rod size.

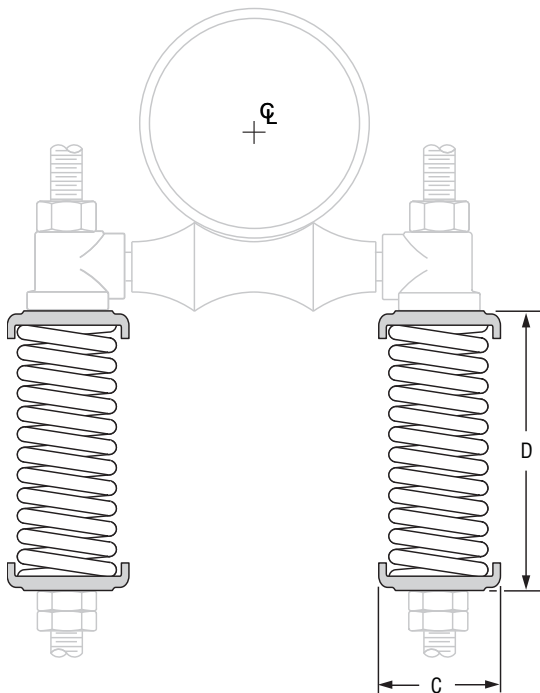
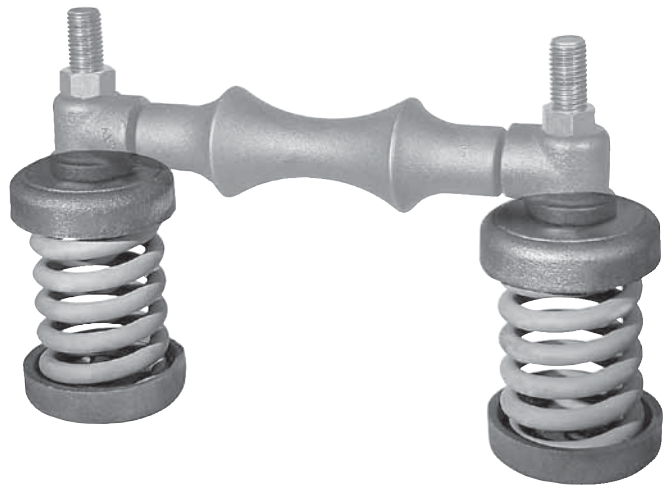

FIG. 178: LOADS (LBS) • WEIGHT (LBS) • DIMENSIONS (IN)

Spring No.	Max Spring Deflection *	Load at Max Deflection ■	Deflection Rate of Hanger (lbs / inch)	Weight	C	D	Core Hole Dia.	For Rod Size	Max Rod Size **
1	1/4	535	428	4.5	2 ²¹ / ₃₂	6 ⁷ / ₁₆	7 ¹ / ₁₆	3/8	3/4
2		1,500	1,200	14.0	4 ¹ / ₈	6 ¹ / ₁₆	9 ¹ / ₁₆	1/2	
3		3,000	2,400	22.0	4 ¹ / ₈	9 ¹ / ₁₆	1 ⁵ / ₁₆	7/8	1 1/2

* At maximum recommended deflection, spring can be compressed an additional 1/4" before becoming solid.

■ Maximum capacity of double spring hanger.

** Can be drilled to max. rod size.

Fig. 181

Adjustable Steel Yoke Pipe Roll

Size Range: 2 1/2" through 24"

Material: Cast iron roll; carbon steel yoke, roll rod and hex nuts

Finish: Plain, Galvanized or Resilient Coated

Service: For suspension of pipe from a single rod where longitudinal movement may occur because of expansion or contraction.

Maximum Temperature: 450° F at roller, 300° F at resilient coated roller.

Approvals: Complies with Federal Specification A-A-1192A (Type 43), WW-H-171-E (Type 44), ANSI/MSS SP-69 and MSS SP-58 (Type 43).

Features: Advantages of pipe rollers with a protective resilient coated covering.

- Non conductive pipe rollers - prevent the passing of current from pipeline to structure.
- Corrosion resistant - for protection against severe weather conditions, moderate corrosive conditions such as marine atmospheres and weather resistant to ultra-violet radiation.
- Low coefficient of friction between pipe and resilient coated pipe roller.

How to size: If the roll is to support bare pipe, select the size directly from nominal pipe size (see below). If used with pipe covering protection saddle, see page 118 for size of pipe roll to be used.

Ordering: Specify pipe roll size, figure number, name and finish. Be certain to order oversized rolls when insulation and protection saddles are required.

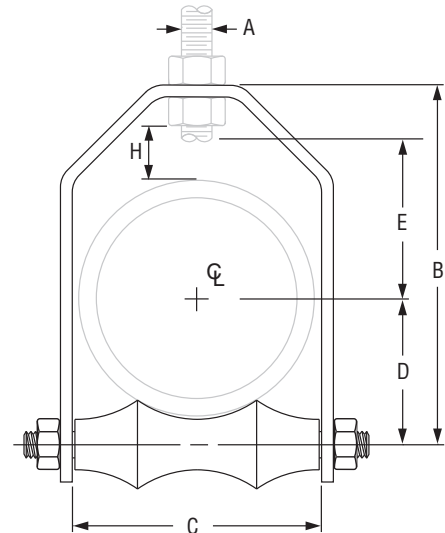
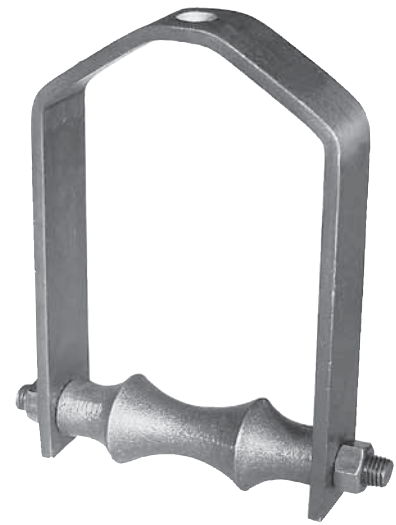

FIG. 181: LOADS (LBS) • WEIGHT (LBS) • DIMENSIONS (IN)									
Pipe Size	Max O.D. of Covering	Max Load	Weight	Rod Size A	B	C	D	Rod Take Out - E	H
2½	3	225	1.7	½	5¾	3¼	1 ¹⁵ / ₁₆	2 ⁷ / ₈	1 ¹¹ / ₁₆
3	3 ⁵ / ₈	310	2.2		6 ³ / ₈	3 ⁷ / ₈	2¼	3 ³ / ₈	1 ⁵ / ₈
3½	4 ¹ / ₈	390	2.5		7	4 ³ / ₈	2 ⁹ / ₁₆	3½	1 ¹¹ / ₁₆
4	4 ¹ / ₁₆	475	3.2	5/8	7 ⁹ / ₁₆	4 ¹⁵ / ₁₆	2 ¹³ / ₁₆	3 ⁵ / ₈	1 ⁵ / ₈
5	5¾	685	6.3		9 ¹ / ₈	6	3 ⁷ / ₁₆	4½	1 ¹⁵ / ₁₆
6	6 ³ / ₈	780	9.3	¾	10 ⁵ / ₁₆	7 ¹ / ₈	4	5	1 ⁷ / ₈
8	9		14.5		12 ¹¹ / ₁₆	9¼	5 ¹ / ₈	6 ³ / ₈	2
10	11	965	18.8	7/8	15 ¹ / ₁₆	11¼	6 ³ / ₈	7¼	2 ¹ / ₁₆
12	13	1,200	27.7		17 ⁷ / ₁₆	13¾	7 ⁷ / ₁₆	8 ³ / ₈	2¼
14	14¼		39.1	1	18 ⁷ / ₈	14½	8 ³ / ₈	8¾	2
16	16¼		49.1		20 ¹³ / ₁₆	16½	9 ³ / ₈	9 ¹¹ / ₁₆	1 ¹⁵ / ₁₆
18	18¼		1,400	57.8	23¾	18½	10 ⁷ / ₁₆	11 ⁷ / ₁₆	2 ¹³ / ₁₆
20	20¼	1,600	75.9	1¼	26	20½	11 ⁵ / ₈	12¼	2½
24	24¼	1,800	119.3	1½	32 ⁵ / ₁₆	24 ⁵ / ₈	13 ¹⁵ / ₁₆	15¾	4 ³ / ₈

DI/CI ROLL SIZING	
DI/CI Pipe Size	Fig. 181 Roller Size
3	4
4	5
6	6
8	8
10	10
12	14
14	16
16	18
18	20
20	24

Fig. 175

Roller Chair

Size Range: 2" through 30" pipe

Material: Cast iron roll, steel chair, roll rod, bolts and hex nuts

Finish: Plain, Galvanized or Resilient Coated

Maximum Temperature: 450° F at roller, 300° F at resilient coated roller.

Service: For support of pipe where longitudinal movement due to expansion and contraction may occur, but where no vertical adjustment is required.

Approvals: Complies with Federal Specification A-A-1192A (Type 44), WW-H-171-E (Type 45), ANSI/MSS SP-69 and MSS SP-58 (Type 44).

Installation: Two bolts and nuts provide anchorage to floor or top of steel beam or bracket or chair may be welded to supporting steel.

Features: Advantages of pipe rollers with a protective resilient coated covering.

- Non conductive pipe rollers - prevent the passing of current from pipeline to structure.
- Corrosion resistant - for protection against severe weather conditions, moderate corrosive conditions such as marine atmospheres and weather resistant to ultra-violet radiation.
- Low coefficient of friction between pipe and resilient coated pipe roller.

How to size:

- (1) If roll is to support bare pipe, select the size directly from nominal pipe size (see below).
- (2) If used with pipe covering protection saddle, see page 118 for size of pipe roll.
- (3) If roll is to support covered pipe, the O.D. of the covering should not be greater than the O.D. of the pipe for which the roll was designed.

Ordering: Specify size of roll, figure number, name and finish. Be certain to order oversized rolls when insulation and protection saddles are required.

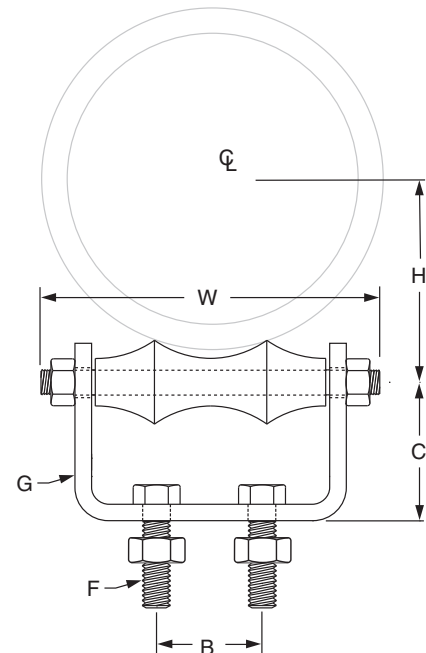
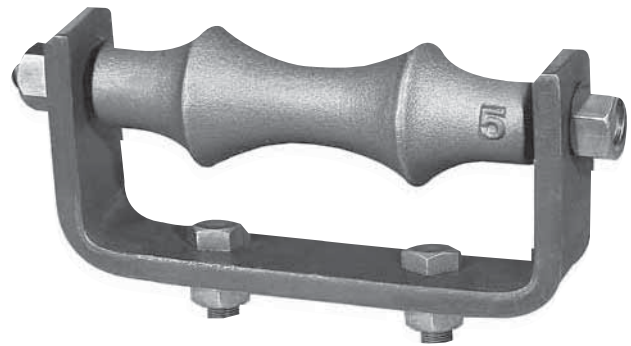

FIG. 175: LOADS (LBS) • WEIGHT (LBS) • DIMENSIONS (IN)

Pipe Size	Max Load	Weight	W	B	C	F	G Width	H
2	600	1.1	4	1 1/4	1 1/2	3/8 x 1 1/2	1 1/4	1 5/8
2 1/2	660	1.4	4 7/8		1 5/8			1 15/16
3	700	1.6	5 3/8		1 3/4			2 1/4
3 1/2	750	2.6	6 1/8	2	2 1/16	1/2 x 1 1/2	1 1/2	2 9/16
4		2.9	6 5/8		2 5/16			2 13/16
5		3.7	7 7/8		3			2 1/2
6	1,070	5.9	9 1/4	3 3/8	2 3/4	5/8 x 1 1/2	2	4
8	1,350	9.0	11 5/8	3 3/8	3			5 1/8
10	1,730	13.8	14 1/8	5 1/4	3 5/8			6 3/8
12	2,400	18.9	16 1/8	5 1/2	4 1/8	5/8 x 2	2	7 7/16
14	3,130	28.07	18 3/4	6 1/2	4 1/16			3/4 x 2
16	3,970	34.93	21	8 1/4	5 3/8	3/4 x 2 1/2	3	9 3/8
18	4,200	44.35	23 1/8	9 1/4	6			10 7/16
20	4,550	56.34	24 5/8	10 1/4	6 1/2			11 5/8
24	6,160	87.52	29 3/8	12 1/4	7 7/8	7/8 x 3 1/2	4	14
30	7,290	151.25	34 13/16	15 3/8	8 3/4			6

DI/CI ROLL SIZING

DI/CI Pipe Size	Fig. 175 Roller Size
3	4
4	5
6	6
8	8
10	10
12	14
14	16
16	18
18	20
20	24
24	30
30	No Recom.

Fig. 277: with Cast Iron Base Plate

Pipe Roll and Base Plate

Size Range: 2" through 24"

Material: Cast iron roll and plate

Finish: Plain, Galvanized or Resilient Coated

Service: For support of pipe where small longitudinal movement due to expansion and contraction may occur and where no vertical adjustment is required.

Maximum Temperature: 450° F at roller, 300° F at resilient coated roller.

Approvals: Complies with Federal Specification A-A-1192A (Type 45) WW-H-171-E (Type 46), ANSI/MSS SP-69 and MSS SP-58 (Type 45).

Installation: Consist of sitting the unit in place. Weight of pipe and material hold unit in place.

How to size:

- (1) If roll is to support bare pipe, select the size directly from nominal pipe size (see below).
- (2) If used with pipe covering protection saddle, see page 118 for size of pipe roll.

Features: An economical, practical means of supporting pipe with limited horizontal movement due to expansion and contraction.

Features: Advantages of pipe rollers with a protective resilient coated covering.

- Non conductive pipe rollers - prevent the passing of current from pipeline to structure.
- Corrosion resistant - for protection against severe weather conditions, moderate corrosive conditions such as marine atmospheres and weather resistant to ultra-violet radiation.
- Low coefficient of friction between pipe and resilient coated pipe roller.

Ordering: Specify pipe roll size, figure number, name and finish.

Be certain to order oversized rolls when insulation and protection saddles are required.

Note: Fabricated carbon steel base plates for extended travel are available upon request. Refer to Fig. 75 SD and 76 SD for additional pipe roll designs.

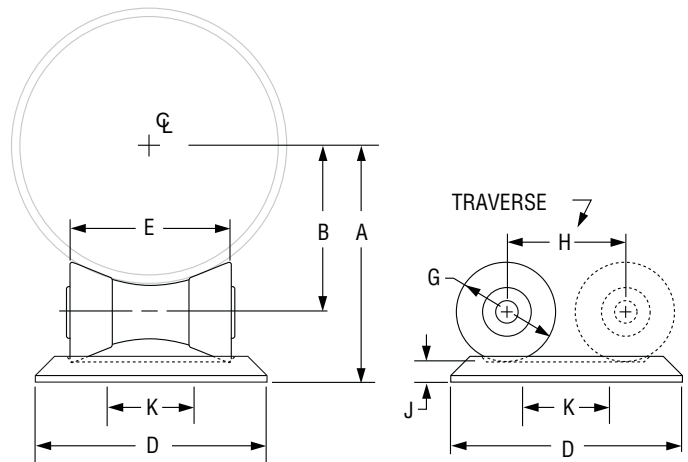
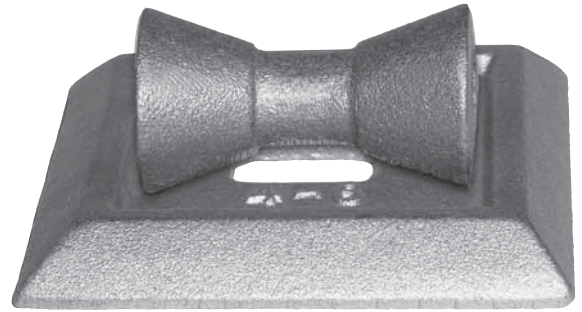

FIG. 277: LOADS (LBS) • WEIGHT (LBS) • DIMENSIONS (IN)

Pipe Size	Max Load	Weight	A	B	D	E	G	H	J	K
2	390	4.0	3/4	1 1/4	4 3/4	2 5/8	1 7/8	1 3/4	1/2	
2 1/2			3 1/2	2 1/8						
3			3 13/16	2 3/8						
3 1/2			4 1/16	2 5/8						
4	950	5.6	4 5/16	2 3/4	5 3/4	3 5/8	2 1/16	2 5/8	1/2	1 1/2
5			4 15/16	3 3/8						
6			5 1/2	4						
8			7 9/16	5 1/4						
10	2,100	15.3	8 11/16	6 3/8	8 1/4	5 5/8	3 1/4	4	1 1/16	2 1/2
12			10 1/4	7 1/2						
14			10 7/8	8 1/8						
16			12 3/8	9 3/8						
18	4,980	43.7	13 1/2	10 5/8	12	8 1/2	4 1/2	6 3/8	7/8	5
20			14 1/2	11 3/8						
24			16 5/8	13 3/8						
24	6,100	51.5	13 3/4	9 1/2	13 3/4	9 1/2	4 7/16	7 5/8	1	5 3/4

DI/CI ROLL SIZING	
DI/CI Pipe Size	Fig. 277 Roller Size
3	4
4	5
6	6
8	8
10	10
12	14
14	16
16	18
18	20
20	24

Fig. 271: Complete

Pipe Roll Stand

Size Range: 2" through 42"

Material: Cast iron roll and stand

Finish: Plain, Galvanized or Resilient Coated

Service: For support of pipe where longitudinal movement due to expansion and contraction may occur but where no vertical adjustment is required.

Maximum Temperature: 450° F at roller, 300° F at resilient coated roller.

Approvals: Complies with Federal Specification A-A-1192A (Type 44), WW-H-171-E (Type 45), ANSI/MSS SP-69 and MSS SP-58 (Type 44).

Installation:

- (1) Two cored holes for anchorage bolts are provided on all sizes for fastening stands to structural supports, piers, floors, etc.
- (2) In addition, cored holes "N" at the four corners of the stand are provided for anchorage purposes.
- (3) The two cored holes on sizes 2" to 6" are on outside of stand (see dotted lines and dimension J').
- (4) On all other sizes, the holes are inside of uprights (see dimension J).

Features: Advantages of pipe rollers with a protective resilient coated covering.

- Non conductive pipe rollers - prevent the passing of current from pipeline to structure.
- Corrosion resistant - for protection against severe weather conditions, moderate corrosive conditions such as marine atmospheres and weather resistant to ultra-violet radiation.
- Low coefficient of friction between pipe and resilient coated pipe roller.

How to size:

- If roll is to support bare pipe, select the size directly from nominal pipe size (see below).
- If used with pipe covering protection saddle, see page 118 for size of pipe roll.

Ordering: Specify pipe roll size, figure number, name and finish. Be certain to order oversized rolls when insulation and protection saddle are required.

Note: Refer to Fig. 75 SD and 76 SD for additional pipe roll designs.

Standard line of carbon steel base plates available.

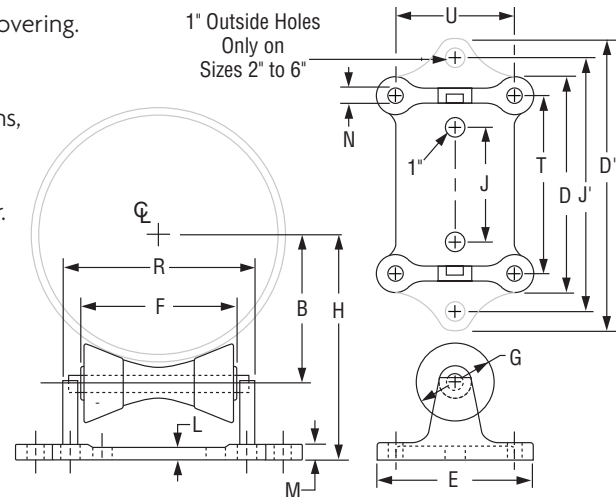
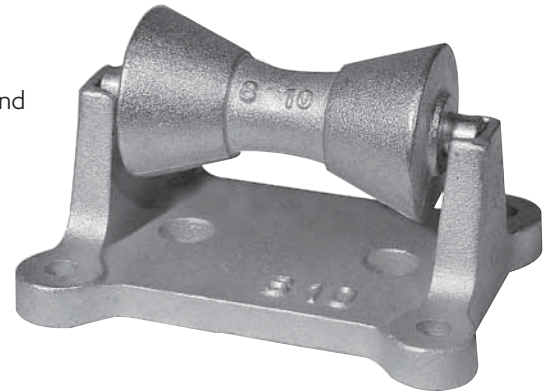

FIG. 271: WEIGHT (LBS) • LOADS (LBS) • DIMENSIONS (IN)																		
Pipe Size	Max Load	Weight	H	B	D	D'	E	F	G	J	J'	L	M	N	R	T	U	
2	390	6.4	3½	1¾	—	8¾	5¾	2¾	1⅞	—	6¾	⅞	11/16	½	4	37/16	4	
2½			3⅞	2½	—					—								
3			4⅞	2¾	—					—								
3½			4¾	2⅝	—					—								
4	950	8.9	4 ¹³ / ₁₆	2¾	—	9⅞	5⅝	3¾	2 ¹ / ₁₆	—	7⅞	¾	7/8	5/8	4 ¹ / ₁₆	4¼	4¼	
5			5 ¹ / ₁₆	3⅞	—					—								
6			6 ¹ / ₁₆	4	—					—								
8	2,100	15.3	8 ¹¹ / ₁₆	5¼	8¾	—	6¾	6	3¼	4	—	¾	7/8	5/8	7¾	7	5	
10			9 ¹ / ₁₆	6¾						—								—
12	3,075	28.1	11¾	7½	10 ¹⁵ / ₁₆	—	7⅞	8	4	5¾	—	¾	7/8	¾	9⅞	9 ¹ / ₁₆	6	
14			12	8½						—								—
16			13¾	9¾						—								—
18	4,980	39.7	14¾	10¾	12¾	—	8¾	9	4½	6¾	—	7/8	1	13/16	11¼	10¼	6½	
20			15¾	11¾						—								—
24	6,100	49.6	17¾	13¾	13½	—	—	10	4 ⁷ / ₁₆	7½	—	1	1⅞	—	12½	11¾	—	
30	7,500	99.3	21¾	16¾	17	—	10¾	12½	5½	10	—	1¼	1½	1½	15¾	14¼	8	
36	12,000	152.0	25¾	20	20	—	12	15	6¾	12	—	1½	1¾	1½	18¾	17	9	
42			28¾	23¾	—	—	—	—	—	—	—	—	—	—	—	—	—	—

DI/CI ROLL SIZING	
DI/CI Pipe Size	Fig. 271 Roller Size
3	4
4	5
6	6
8	8
10	10
12	14
14	16
16	18
18	20
20	24
24	30
30	N/A

Fig. 274: with Base Plate
Fig. 275: without Base Plate
Fig. 274P: Cast Iron Base Plate only

Adjustable Pipe Roll Stand

Size Range: 2" through 42"

Material: Cast iron base plate, stand roll; steel adjusting screws

Finish: Plain, Galvanized or Resilient Coated

Service: For support of pipe lines where longitudinal movement due to expansion and contraction may occur and where vertical and lateral adjustment during installation may be required.

Maximum Temperature: 450° F at roller, 300° F resilient coated roller.

Approvals: Complies with Federal Specification A-A-1192A (Type 46), WW-H-171-E (Type 47), ANSI/MSS SP-69 and MSS SP-58 (Type 46).

Installation: Base plate is provided with two holes for anchorage to floor, pier, structural support and similar constructions, as well as to welded steel brackets Fig. 195 page 77 and Fig. 199, page 78. Adjustable pipe roll stand *without base plate*, Fig. 275, can be used for supporting tunnel piping, etc., by resting ends of adjusting screws on structural steel angles, channels, etc.

Adjustment: Vertical adjustment is obtained by use of the four adjusting screws located on corners of stand. Lateral adjustment is secured by stand sliding on each of adjusting screws.

Features: Advantages of pipe rollers with a protective resilient coated covering.

- Non conductive pipe rollers - prevent the passing of current from pipeline to structure.
- Corrosion resistant - for protection against severe weather conditions, moderate corrosive conditions such as marine atmospheres and weather resistant to ultra-violet radiation.
- Low coefficient of friction between pipe and resilient coated pipe roller.

How to size:

- (1) If roll is to support bare pipe, select the size directly from nominal pipe size (see below).
- (2) If used with pipe covering protection saddle, see page 118 for size of pipe roll.

Ordering: Specify pipe roll size, figure number, name and finish. For further dimensions of stand, see Fig. 271, page 128. Be certain to order oversized rolls when insulation and protection saddles are required.

Note: Refer to Fig. 75 SD and 76 SD for additional pipe roll designs.

Standard line of carbon steel base plates available.

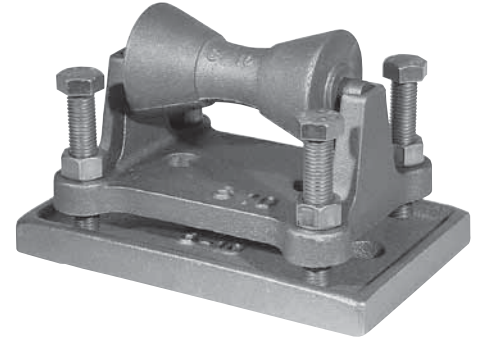

See Fig. 271 for Additional Dimensions

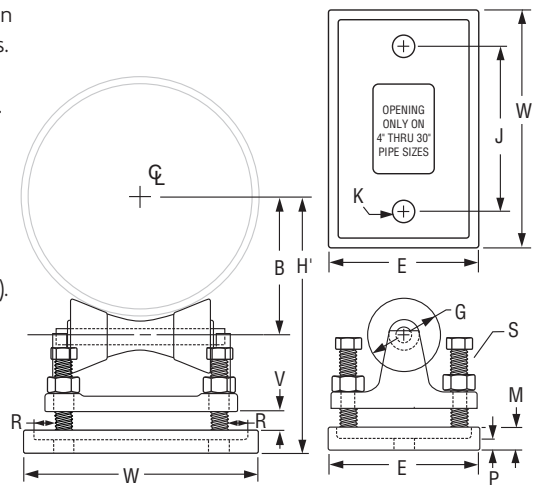

FIG. 274, 275, 274P: DIMENSIONS (IN)

Pipe Size	Max Load	Weight			H' Min	H' Max	E	J	K	V Max	M	P	R	S	W
		Fig. 274	Fig. 275	Fig. 274P											
2	390	15.2	7.8	7.4	5 1/8	5 3/8	5 1/2	3 3/8	1	7/8	1	3/4	1	3/4	6 7/8
2 1/2					5 3/8	5 5/8									
3					5 3/4	6									
3 1/2					6	6 1/4									
4	950	19.3	10.3	9.0	6 1/2	7	5 3/4	5 1/8	1	1 1/8	1	3/4	1	3/4	8 1/8
5					7	7 1/2									
6					7 5/8	8 1/8									
8	2,100	32.1	18.1	14.0	10 3/8	11 1/8	6 3/4	7 3/8	1	1 3/4	1 1/8	1 1/16	1	3/4	10 5/8
10					11 1/2	12 3/4									
12	3,075	51.2	32.1	19.1	13	14 1/4	8	9 1/2	1	1 3/4	1 1/8	3/4	1	7/8	13
14					13 3/8	14 7/8									
16	4,980	71.3	45.3	26.0	15 1/4	16 3/8	8 5/8	11 1/8	1	1 7/8	1 1/4	7/8	1 1/16	1	14 5/8
18					16 3/8	17 3/4									
20					17 3/8	18 3/4									
24	6,100	87.0	55.0	32.0	19 5/8	21	11	19	1 1/8	4 1/2	2	1 1/2	2 1/4	1 1/2	23
30	7,500	166.2	109.2	57.0	24	26 3/4									
36	12,000	304.0	176.0	128.0	28 3/8	31 3/4	11	19	1 1/8	4 1/2	2	1 1/2	2 1/4	1 1/2	23
42					31 1/2	34 3/8									

DI/CI ROLL SIZING	
DI/CI Pipe Size	Fig. 274 Roller Size
3	4
4	5
6	6
8	8
10	10
12	14
14	16
16	18
18	20
20	24
24	30
30	N/A

Fig. 255

Pipe Alignment Guide

Size Range: 1" through 24" pipe and insulation thickness of 1" through 4"

(Also available in copper tube sizes, see page 24)

Material: Carbon steel

Finish: Plain or Galvanized

Service: For maintaining alignment of piping through its axial expansion and contraction cycles. Normally, two or more pipe alignment guides are used on a single piping run to avoid a pivoting effect within the piping system. It is recommended that the first guide be located a maximum of four pipe diameters from an expansion joint.

The second guide should be placed a maximum of 18 pipe diameters from an expansion joint. Additional guides should be employed in accordance with the guide spacing data shown on next page. Supports are usually required between the intermediate guides to comply with standard support practice.

Maximum Temperature: 650° F

Installation:

- (1) Attach outer housing to structure by bolting or welding.
- (2) Remove upper section of housing to open position.
- (3) Attach spider clamp to pipe and completely insulate.
- (4) Set pipe and spider clamp into outer housing.
- (5) Replace upper section of housing to closed position and secure.

Note: Spider attachments to pipe must be properly located during installation to insure that a minimum of one-half the spider width remains within the length of the outer housing for all conditions of operation. See table on opposite page for maximum recommended travels. If larger travels are required, special guides can be furnished to special order.

How to size: Size by nominal pipe size and insulation thickness in accordance with the selection table on the opposite page.

Ordering: Specify size number, pipe size, insulation, thickness, figure number, name and finish.

Caution: The primary function of the Figure 255 is to maintain axial alignment of a system. Other components should be incorporated into the system to carry the primary loading of the system. Guides are designed such that minor loading amounts may be transferred to the guide in any given direction, up to 20% of dead weight load for typical maximum spans of a given pipe diameter.

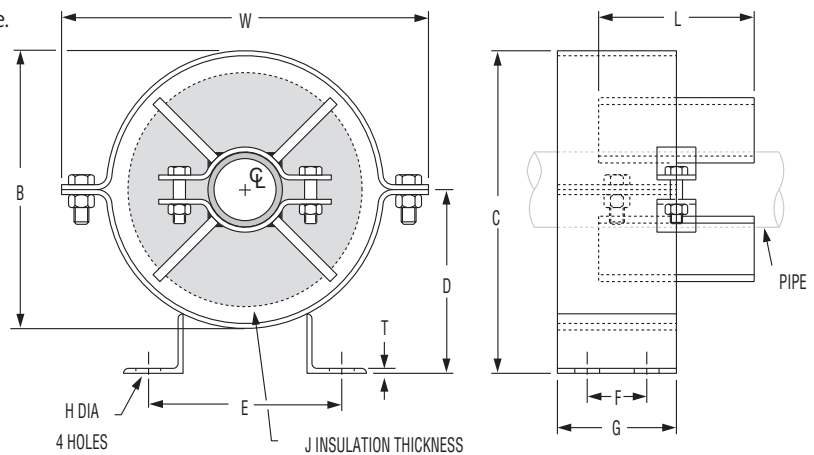
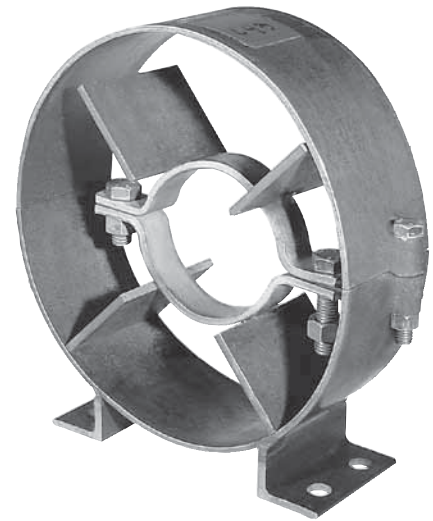

Pipe Alignment Guide
Figure 255, Size A & B

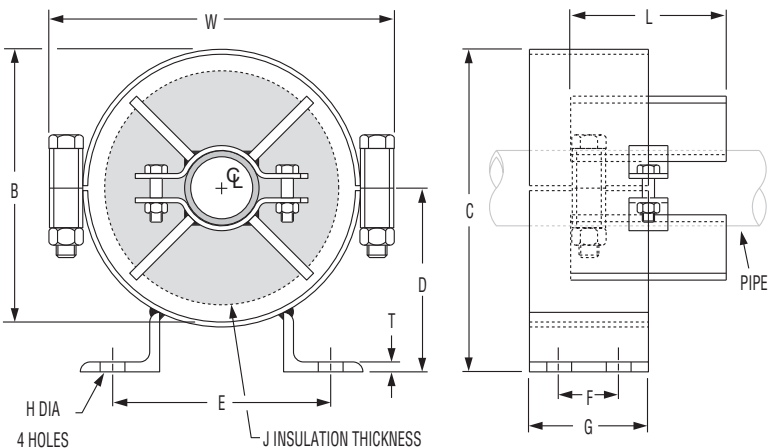

Pipe Alignment Guide
Figure 255, Size C thru J

Pipe Size (in)	L (in)	Maximum Movement
1" to 6"	4	4
8" to 16"	6	6
18" to 24"	8	8

Dimensional Data on Following Page.

Fig. 255

Pipe Alignment Guide (cont.)

GUIDE SIZE NUMBER						
Pipe Size	Insulation Thickness (in)					
	1	1½	2	2½	3	4
1						
1¼	A	A	A	B	B	C
1½						
2	B	B	B	C	C	D
2½						
3						
3½						
4	C	C	C	D	D	E
5						
6	D	D	D	E	E	F
8	–	E	E	E	F	F
10	–	F	F	F	F	G
12	–					
14	–	–	G	G	G	H
16	–	–				
18	–	–	–	–	H	H
20	–	–	–	–	J	J
24	–	–	–	–	J	J

GUIDE SIZE SELECTION TABLE									
Locate bare nominal pipe size in appropriate insulation thickness column and read guide size from "Guide Size No." column to the left.									
Guide Size No.	Dimensions (in)								
	W	B	C	D	E	F	G	H	T
A	8 ¹³ / ₁₆	6¾	8 ⁷ / ₈	4 ⁵ / ₁₆	6¾	2½	4	5 ⁵ / ₈	¼
B	10 ¹³ / ₁₆	8¾	9 ⁷ / ₈	5 ⁵ / ₁₆	7 ³ / ₈				
C	13 ³ / ₁₆	11¼	12 ⁷ / ₁₆	6 ⁵ / ₈	7 ⁷ / ₈				
D	15 ⁷ / ₈	13 ³ / ₈	14 ¹³ / ₁₆	7 ¹⁵ / ₁₆	9¾	4	6	¾	¾
E	18	15½	17 ¹ / ₁₆	9 ⁵ / ₈					
F	22¼	19¾	21 ¹ / ₁₆	11	14 ¹ / ₈	5½	8	1	¾
G	28	25	26¼	13 ³ / ₁₆	15 ⁷ / ₈				
H	32 ³ / ₈	29¼	30¾	15 ⁷ / ₈	16 ³ / ₈				
J	37 ⁵ / ₈	34½	36 ⁵ / ₈	18 ⁵ / ₈	17 ⁷ / ₈				

Pipe Size* (in)	Maximum Distance (feet) Between Intermediate Guides for Pressure (psig)									
	50	100	150	200	250	300	350	400	500	600
3	38	27	22	20	18	17	15	14	13	12
4	52	37	32	27	25	23	22	19	17	16
6	66	47	40	35	31	28	27	25	23	20
8	85	62	51	45	40	36	35	32	29	27
10	103	75	62	54	50	45	42	40	35	32
12	118	85	70	60	55	50	46	43	40	35
14	120	87	72	62	57	52	48	45	41	37
16	130	95	78	68	61	57	52	49	45	41
18	145	105	87	75	68	62	58	55	50	45
20	155	110	92	90	73	68	62	58	53	49
24	180	128	105	90	83	75	70	65	60	54

* For pipe sizes not shown refer to the Expansion Joint Manufacturers Association Guidelines

Straps
Pipe Supports
Trapeze
Pipe Shields & Saddles
Pipe Roll
Pipe Guides & Slides
Spring Hangers
Constant Supports
Vibration Control & Sway Brace
Sway Strut Assembly
Snubbers
Special Design Products
Application Examples
Master Format 3 Part Specs.
Technical Data
Index

Fig. 256

Pipe Alignment Guide

Size Range: 1" through 24" pipe and insulation thickness of 1" through 4"

Material: Carbon steel

Finish: Plain or Galvanized

Service: For maintaining alignment of piping through its axial expansion and contraction cycles. Normally, two or more pipe alignment guides are used on a single piping run to avoid a pivoting effect within the piping system. It is recommended that the first guide be located a maximum of four pipe diameters from an expansion joint. The second guide should be placed a maximum of 18 pipe diameters from the expansion joint. Additional guides should be employed in accordance with the guide spacing data on next page. Supports are usually required between the intermediate guides to comply with standard support practice.

Maximum Temperature: 750° F

Installation:

- (1) Attach outer housing to structure by bolting or welding.
- (2) Swing upper section of housing to open positions.
- (3) Attach spider clamp to pipe and completely insulate.
- (4) Set pipe and spider clamp into outer housing.
- (5) Replace upper section of housing to closed position and secure.

Note: Spider attachments to pipe must be properly located during installation to insure that a minimum of one-half the spider width remains within the length of the outer housing for all conditions of operation. See table on opposite page for maximum recommended travels. If larger travels are required, special guides can be furnished to special order.

How to size: Size by nominal pipe size and insulation thickness in accordance with the selection table on opposite page.

Ordering: Specify size number, pipe size, insulation thickness, figure number, name and finish.

Caution: The primary function of the Figure 256 is to maintain axial alignment of a system. Other components should be incorporated into the system to carry the primary loading of the system. Guides are designed such that minor loading amounts may be transferred to the guide in any given direction, up to 20% of dead weight load for typical maximum spans of a given pipe diameter.

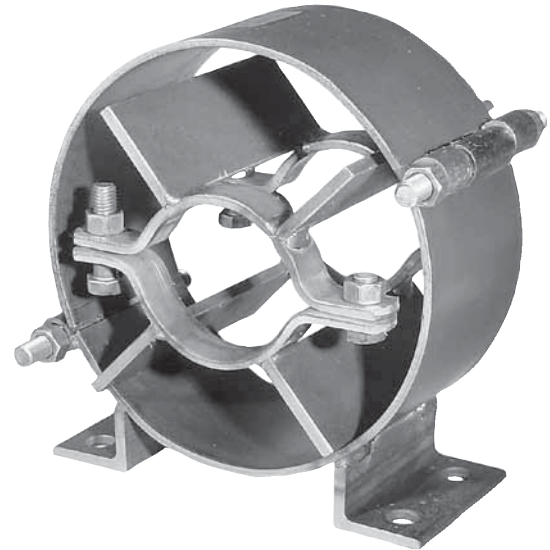

Pipe Size (in)	L (in)	Maximum Movement
1" to 6"	6	6
8" to 16"	8	8
18" to 24"	10	10

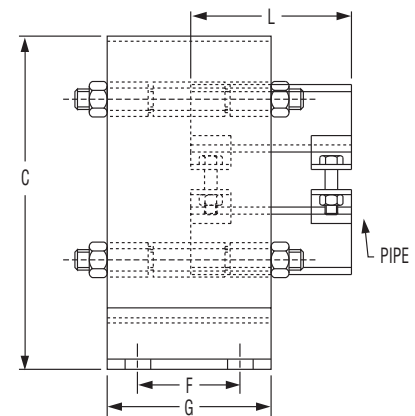
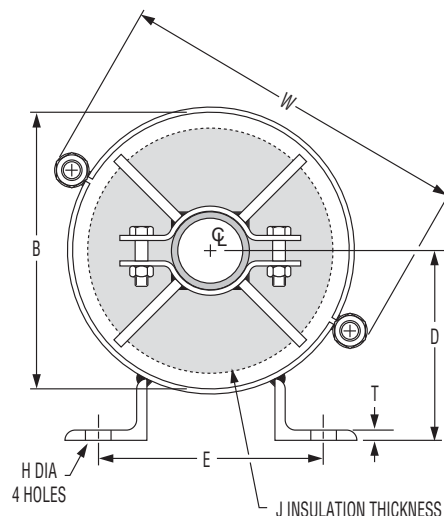

Dimensional Data on Following Page.

Fig. 256

Pipe Alignment Guide (cont.)

GUIDE SIZE NUMBER						
Pipe Size	Insulation Thickness (in)					
	1	1½	2	2½	3	4
1	A	A	A	B	B	C
1¼	A	A	A	B	B	C
1½	A	A	A	B	B	C
2	B	B	B	B	C	C
2½	B	B	B	B	C	D
3	B	B	B	C	C	D
3½	B	B	B	C	C	D
4	C	C	C	C	C	D
5	C	C	C	D	D	E
6	D	D	D	D	E	E
8	–	E	E	E	E	F
10	–	F	F	F	F	F
12	–	F	F	F	F	G
14	–	–	G	G	G	G
16	–	–	G	G	G	G
18	–	–	–	–	H	H
20	–	–	–	–	H	H
24	–	–	–	–	J	J

GUIDE SIZE SELECTION TABLE									
Locate bare nominal pipe size in appropriate insulation thickness column and read guide size from "size no." column to the left.									
Guide Size No.	Dimensions (in)								
	W	B	C	D	E	F	G	H	T
A	8 ¹³ / ₁₆	6 ³ / ₄	7 ⁷ / ₈	4 ⁵ / ₁₆	6 ³ / ₄	2½	4	5 ⁵ / ₈	¼
B	10 ¹³ / ₁₆	8 ³ / ₄	9 ⁷ / ₈	5 ⁵ / ₁₆	7 ³ / ₈				
C	13 ³ / ₄	11¼	12 ⁷ / ₁₆	6 ⁵ / ₈	7 ⁷ / ₈	4	6	¾	¾
D	15 ⁷ / ₈	13 ³ / ₈	14 ¹³ / ₁₆	7 ¹⁵ / ₁₆	9 ³ / ₄				
E	18	15½	17 ¹ / ₁₆	9 ⁷ / ₈		5½	8	1	¾
F	22¼	19¾	21 ¹ / ₁₆	11	14 ¹ / ₈				
G	28	25	26¼	13 ¹³ / ₁₆	15 ⁷ / ₈				
H	32 ³ / ₈	29¼	30¾	15 ⁷ / ₈	16 ³ / ₈				
J	37 ⁵ / ₈	34½	36 ⁵ / ₈	18 ⁵ / ₈	17 ⁷ / ₈				

RECOMMENDED EXPANSION JOINT GUIDE SPACING										
Pipe Size* (in)	Maximum Distance (feet) Between Intermediate Guides for Pressure (psig)									
	50	100	150	200	250	300	350	400	500	600
3	38	27	22	20	18	17	15	14	13	12
4	52	37	32	27	25	23	22	19	17	16
6	66	47	40	35	31	28	27	25	23	20
8	85	62	51	45	40	36	35	32	29	27
10	103	75	62	54	50	45	42	40	35	32
12	118	85	70	60	55	50	46	43	40	35
14	120	87	72	62	57	52	48	45	41	37
16	130	95	78	68	61	57	52	49	45	41
18	145	105	87	75	68	62	58	55	50	45
20	155	110	92	90	73	68	62	58	53	49
24	180	128	105	90	83	75	70	65	60	54

* For pipe sizes not shown refer to the Expansion Joint Manufacturers Association Guidelines

PTFE Pipe Slide Assemblies

Overview

Application

Anvil PTFE pipe slide assemblies are designed to support the pipe and provide for lateral and axial movement due to thermal expansion and contraction of the piping system.

Assemblies are fabricated using PTFE slide bearings to provide a low coefficient of friction, minimizing frictional stress on the pipe and support structure.

Features

- Pre-engineered to save calculation and installation time.
- PTFE slide bearing pads are composed of 100% virgin Polytetrafluoroethylene polymer.
- Capable of supporting constant loads up to 2000 PSI at 70° F
- Coefficient of friction typically ranges between 0.06 and 0.2 depending on bearing surface area, bearing load (sample ranges shown in chart for given pressures at 70°F). Consult your Anvil representative for further information. The low coefficient of friction for the PTFE slide assemblies permits a smooth, unrestrained movement of the pipe and reduces overturning movements on supporting structures.
- PTFE is chemically inert and resists attack by chemicals, humidity and other elements found in harsh environments provided that the steel supports are suitably protected.
- Self-lubricating, maintenance-free.
- Provides resistance to galvanic corrosion between pipe and support structure.
- Maximum temperature: 400° F at PTFE
- Allows for up to 4" insulation thickness as standard. Greater than 4" insulation available on special request. Special designed slides and tees available on request.

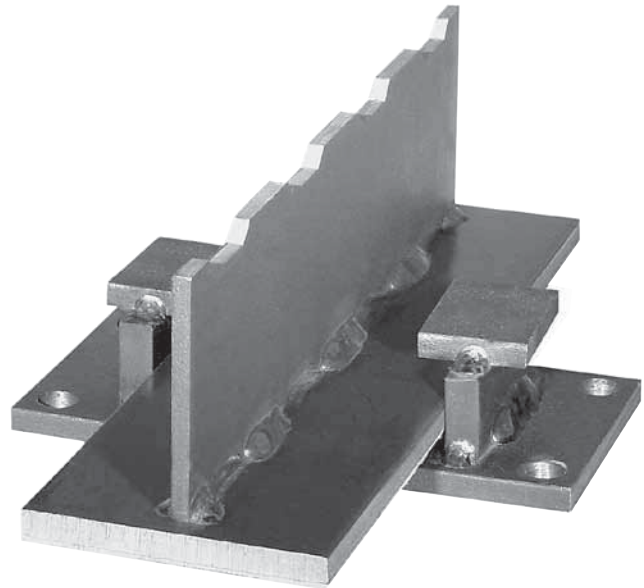

Selection

- (1) Determine the support location based on allowable span and loading conditions.
- (2) Calculate the load for each slide assembly location.
- (3) Determine the lateral and axial movement of the pipe and the direction of movement, cold to hot.
- (4) Select pipe slide or tee figure number and attachment configuration, welded or bolted.
- (5) Select the method of slide plate attachment to support structure, welded or bolted.
- (6) Designate whether guided or non-guided slide plate is required.
- (7) Maximum recommended loads shown for pipe slides and structural tees are for vertical loading. Transitional loads for pipe structural tees are to be determined by customer.

Installation

- (1) Determine offset of pipe slide-slide plate interface to allow maximum pipe movement in direction of greatest thermal displacement.
- (2) Attach PTFE slide to pipe by welding or clamping with standard Fig. 212 pipe clamp or Fig. 432 special pipe clamp.
- (3) Attach slide plates to supporting structure by bolting or welding.
- (4) Verify setting to insure full bearing between the PTFE slide and slide base surfaces under all pipe movement conditions.

PTFE Pipe Slide Assemblies

Overview (cont.)

The maximum load on the pipe slides is based on using a PTFE width of 2" for the slide plate and a 70° F temperature. For a different temperature at the bearing surfaces, multiply the maximum load rating by the following factor.

Temperature °F	Factor
70	1.00
100	0.85
200	0.55
300	0.40
400	0.25

COEFFICIENT OF FRICTION VERSUS PRESSURE

Test Speed: 1"/min. (25mm/min.)

Temperature: 70°F (21°C)

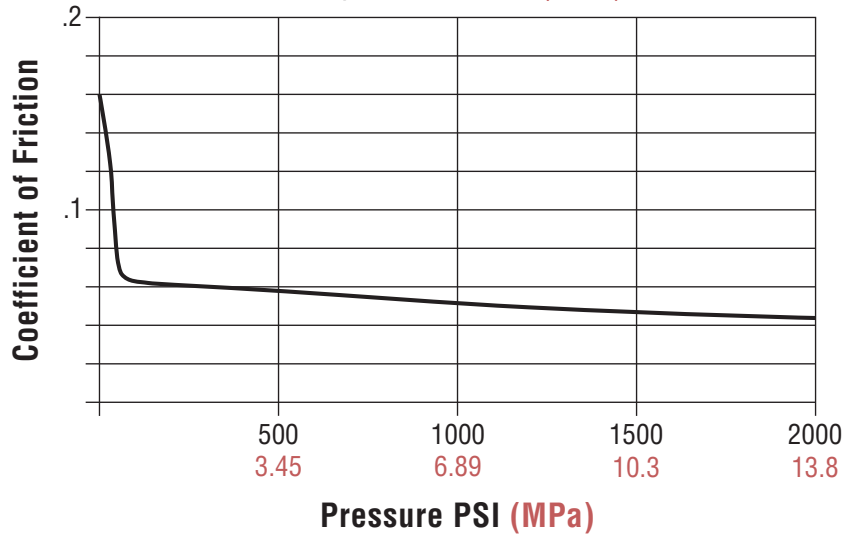

- Straps
- Pipe Supports
- Trapeze
- Pipe Shields & Saddles
- Pipe Roll
- Pipe Guides & Slides**
- Spring Hangers
- Constant Supports
- Vibration Control & Sway Brace
- Sway Strut Assembly
- Snubbers
- Special Design Products
- Application Examples
- Master Format 3 Part Specs.
- Technical Data
- Index

Fig. 257: Structural Tee Slide Assembly

Fig. 257A: Structural Tee

Fig. 436: Fabricated Tee Slide Assembly

Fig. 436A: Fabricated Tee

Pipe Slides Assembly, Complete

Size Range: All sizes within maximum load rating.

Material: Carbon steel tee, PTFE bonded slide plates and carbon steel base.

Finish: Plain, Painted or Galvanized

Service: For the support of piping where horizontal movement resulting from expansion and contraction takes place and where a low coefficient of friction is desired.

Approvals: Complies with Federal Specification A-A-1192A (Type 35), ANSI/MSS SP-69 and MSS SP-58 (Type 35).

Maximum Load: As indicated at 70° F see page 135 for rating factor at higher temperatures.

Maximum Temperature: 750° F

Temperature Range at PTFE: -20° F to 400° F

Features:

- No lubrication required.
- Designed to minimize heat loss.
- Allows up to 3" of insulation on Types 1, 2, 4 & 5 and up to 2 1/2" of insulation on Types 3 & 6.
- Allows up to 10" travel standard
- Weld in place design.

Available Options:

- Increased travels.
- Increased tee heights.
- End plates.
- Clamps, Fig. 212 or Fig. 432.
- Base plate with mounting holes
- High temperature option, 1000° F (Fig. 436) Stainless steel tee slide with an insulated PTFE slide

Ordering: Specify figure number, type, name, finish and any other option desired.

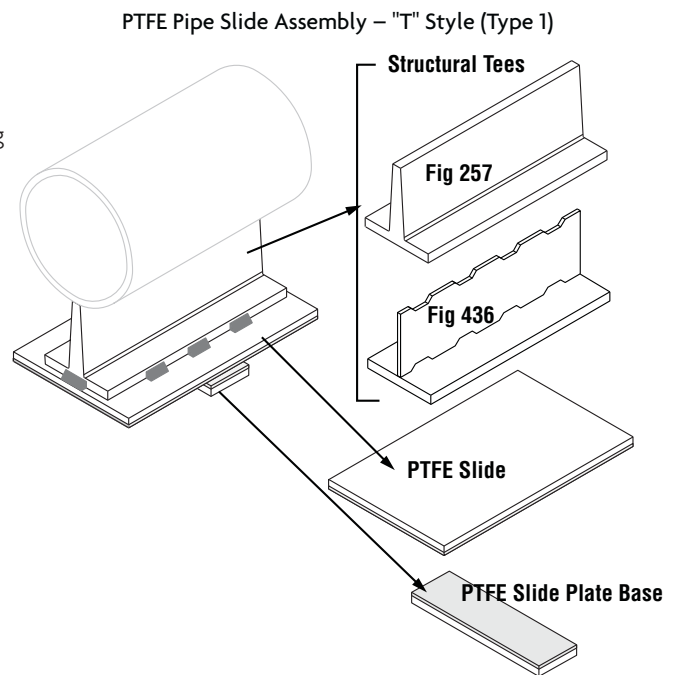

Note: In the PH-92 and PH-92R Catalogs:

The Fig. 257 & 436 (slide "T" section only) formerly referred to as Fig. 280 & 435

The Fig. 257 & 436 (slide base plate) formerly referred to as Fig. 438 (slide base plate)

The acceptability of galvanized coatings at temperatures above 450°F is at the discretion of the end user.

FIG. 257, 436: LOADS (LBS) • DIMENSIONS (IN) • WEIGHTS (LBS)

Figure Number	Type	Max Load			Welded Slide				Bolted Slide					
		Down	Side *	Up	H **	W	BL	Weight	H **	W	BL	Hole Locations	Bolt Size	Weight
Fig. 257	Tee	8,000	2,000	800	3 15/16	4	12	7.00	-	-	-	-	1/2	-
	1				4 3/4	4	2	11.93	4 3/4	-	-	-		15.25
	2				5	8	4	16.10	5	8	4	2 1/2 x 6 1/2		16.10
	3				5	11 1/2	5	16.95	5	11 1/2	5	3 1/2 x 10		16.95
	4				4 3/4	6	2	12.47	4 3/4	-	-	-		18.36
	5				5	11 1/2	5	18.81	5	11 1/2	5	3 1/2 x 10		19.21
6	5	11 1/2	5	19.66	5	11 1/2	5	3 1/2 x 10	20.06					
Fig. 436	Tee	8,000	2,000	800	4	4	12	7.00	-	-	-	-	1/2	-
	1				4 1 1/16	4	2	15.42	4 1 1/16	-	-	-		18.74
	2				4 15/16	8	4	19.59	4 15/16	8	4	2 1/2 x 6 1/2		19.59
	3				4 15/16	8	4	20.44	4 15/16	8	4	2 1/2 x 6 1/2		20.44
	4				4 1 1/16	6	2	15.97	4 1 1/16	-	-	-		21.85
	5				4 15/16	11 1/2	5	22.30	4 15/16	11 1/2	5	3 1/2 x 10		22.70
6	4 15/16	11 1/2	5	23.15	4 15/16	11 1/2	5	3 1/2 x 10	23.55					

* Side load is only applicable if appropriate endplates are added to slide or "T" Section

** With the Fig. 432 clamp, add the material thickness. The Tees are now being notched for the material thickness when welding on the Fig. 212 See page 141.

Fig. 257 and 436 PTFE Pipe Slide Assemblies

Straps
Pipe Supports
Trapeze
Pipe Shields & Saddles
Pipe Roll
Pipe Guides & Slides
Spring Hangers
Constant Supports
Vibration Control & Sway Brace
Sway Strut Assembly
Snubbers
Special Design Products
Application Examples
Master Format 3 Part Specs.
Technical Data
Index

Notes:

- Types 1, 2, and 3 provide for longitudinal movement only.
- Types 4, 5, and 6 provide for both longitudinal and transverse movement of piping.

Structural Tee

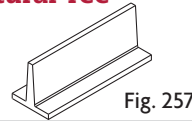

Fabricated Tee

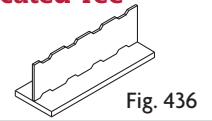

Type 1

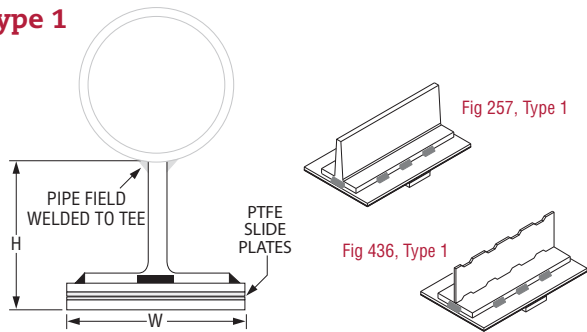

Type 2

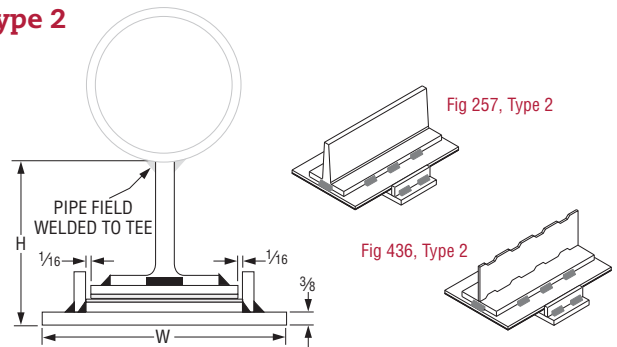

Type 3

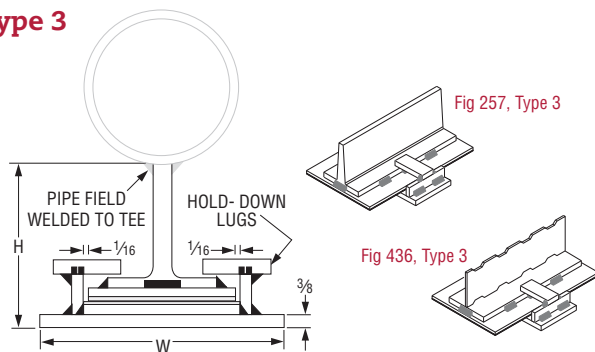

Type 4

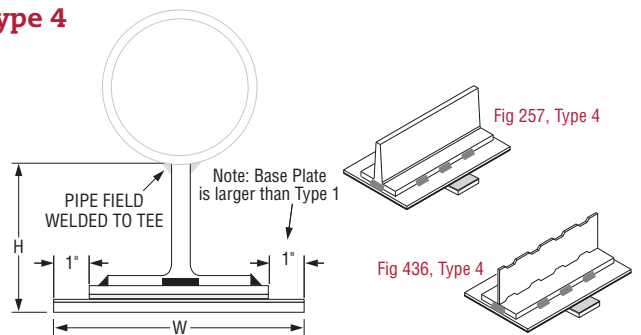

Type 5

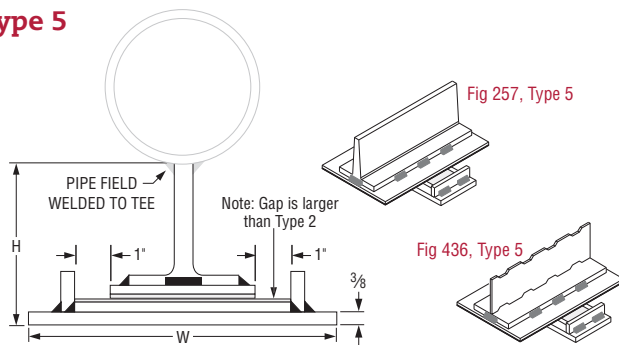

Type 6

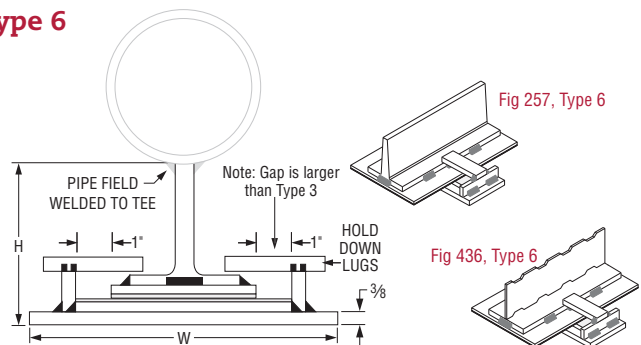

Side View, All Types

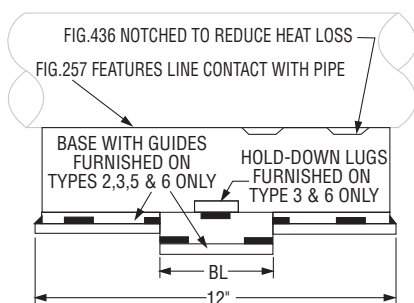

Options (for all types)

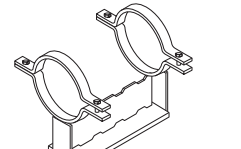
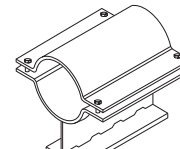
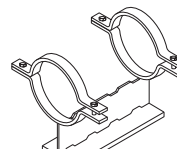
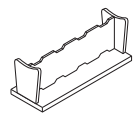
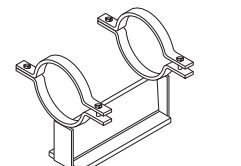
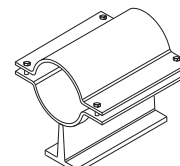
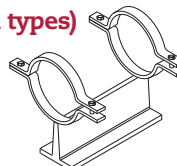
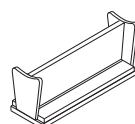

Fig. 439: Structural "H" Slide Assembly
Fig. 439A: Structural "H"

Pipe Slide Assembly, Complete

Size Range: 6" through 36"

Material: Carbon steel "H" section, PTFE bonded slide plates and carbon steel base.

Finish: Plain, Painted or Galvanized

Service: A heavy duty slide support where horizontal movement resulting from expansion and contraction takes place and where a low coefficient of friction is desired.

Approvals: Complies with Federal Specification A-A-1192A (Type 35), ANSI/MSS SP-69 and MSS SP-58 (Type 35).
Maximum Load: As indicated at 70° F see page 135 for rating factor at higher temperatures.

Maximum Temperature: 750° F

Temperature Range at PTFE: -20° F to 400° F

Features:

- No lubrication required.
- Allows up to 4" of insulation.
- Allows up to 10" travel standard.
- Weld in place design.

Available Options:

- Increased travels.
- Increased "H" Section heights.
- Clamps, Fig. 212 or Fig. 432.
- Base plate with mounting holes. The bolt spacing for the bolted base plates is equal to the "W" dimension minus 1 1/2" and the "BL" dimension minus 1 1/2" for all pipe sizes and the hole diameter is 9/16" for all sizes.

Ordering: Specify figure number, type, name, finish and any other option desired.

Notes: Types 1, 2, and 3 provide for longitudinal movement only. Types 4 and 5 provide for both longitudinal and transverse movement of piping.

PTFE Pipe Slide Assembly – "H" Type

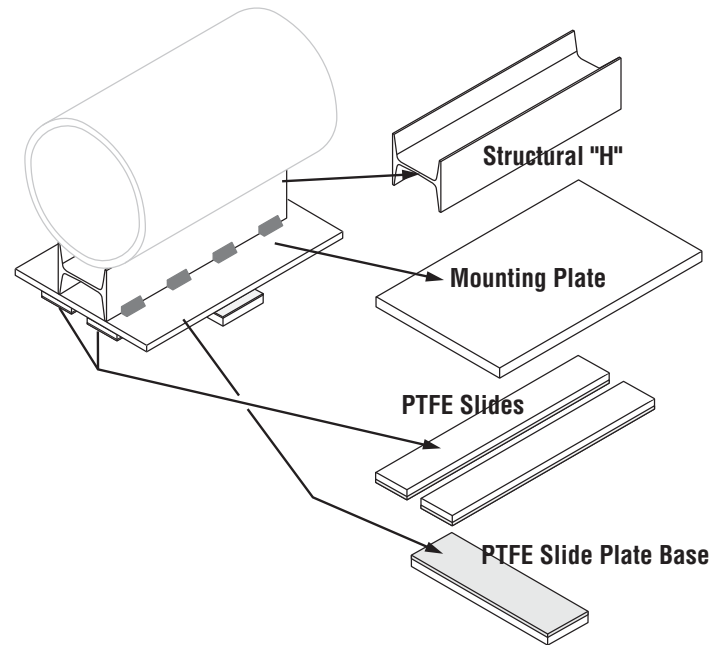

Note: In the PH-92 and PH-92R Catalogs:

The Fig. 439 (slide "H" section only) formerly referred to as Fig. 437.

The Fig. 439 (slide base plate) formerly referred to as Fig. 438 (slide base plate).

The acceptability of galvanized coatings at temperatures above 450°F is at the discretion of the end user.

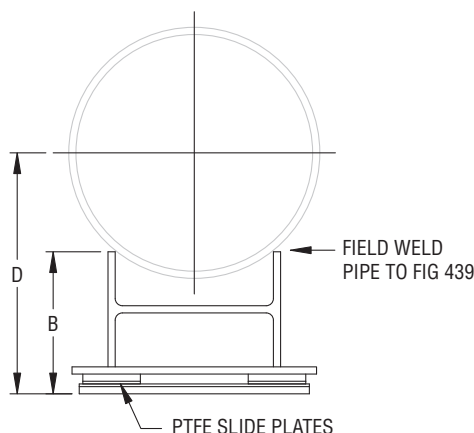

FIG. 439: LOADS (LBS) • DIMENSIONS (IN)

Pipe Size	B			D *			Max Load					
	Type			Type			Down	Side Type 2, 3, 5	Up Type 3			
	1 & 4	2 & 5	3	1 & 4	2 & 5	3						
6	5	5 1/4	5 5/16	7 3/4	8	8	12,000	3,000	1,200			
8				8 3/4	9	9						
10	5 1/8	5 3/8	5 7/16	9 5/8	9 7/8	9 15/16				16,000	4,000	1,600
12				10 3/4	11	11 1/16						
14				10 7/8	11 1/8	11 3/16						
16				12 1/8	12 3/8	12 1/16						
18				12 5/8	12 7/8	12 15/16						
20	5 1/4	5 1/2	5 9/16	13 3/4	14	14 1/16	24,000	6,000	2,400			
24				15 5/8	15 7/8	15 15/16						
30				19 5/8	19 7/8	20 1/16						
36	6 7/16	6 13/16	6 3/4	23	23 3/4	23 7/16						

* With clamps; add material thickness of a Fig. 212 for bolted bases add 5/16" to height "H" dimension.

** With the Figure 432 special clamp, add the material thickness of Figure 432. See page 140.

Fig. 439

Structural "H" Slide Assembly, Complete

WELDED: DIMENSIONS (IN)						
Pipe Size	W Type				BL Type	
	1	2 & 3	4	5	1 & 4	2, 3, & 5
	6	5 1/2	10	7 1/2	10	2
8						
10						
12						
14						
16	10	14 1/2	12 1/2	14 1/2	3	
18	12	17	14 1/2	17		
20	14	19	16 1/2	19		
24	16	21	18 1/4	21		
30	18	23	20 1/4	23		

BOLTED: DIMENSIONS (IN)				
Pipe Size	W Type 1 to 5	BL Type 1 to 5	Hole Spacing	
			C	G
6	10	6	8 1/2	4 1/2
8				
10	12 1/2		11	
12				
14	14 1/2		13	
16				
18	17		15 1/2	
20				
24	19		17 1/2	
30	21		19 1/2	
36	23	21 1/2		

WELDED SCHEMATICS

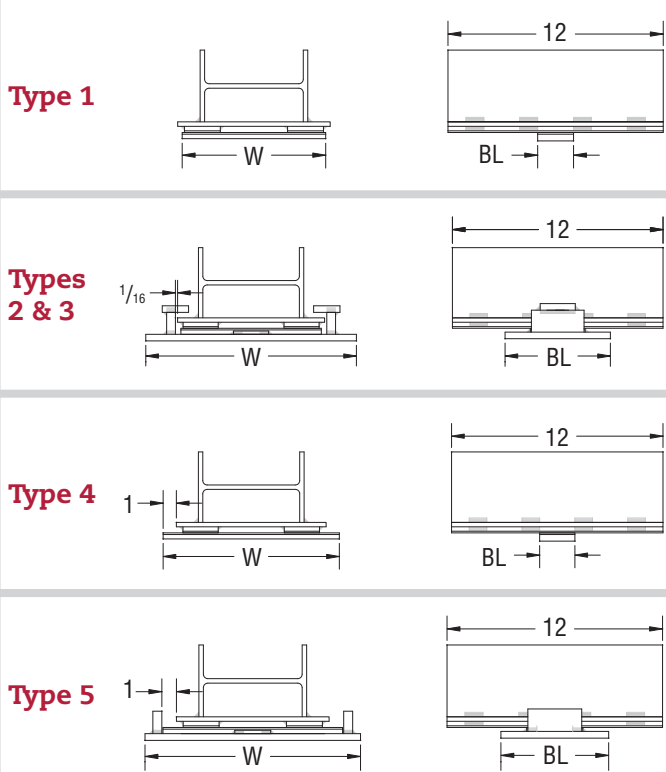

BOLTED SCHEMATICS

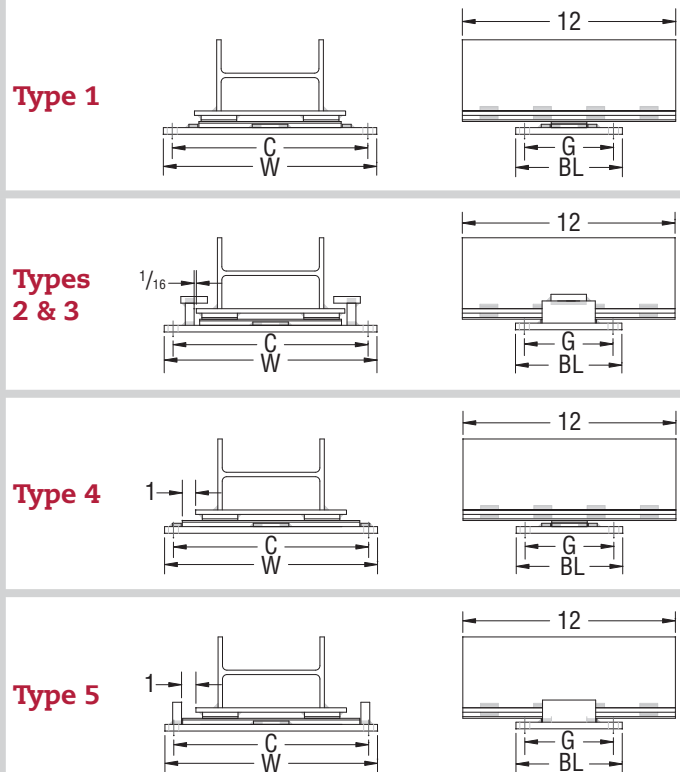

Notes:

- Types 1, 2, and 3 provide for longitudinal movement only.
- Types 4 and 5 provide for both longitudinal and transverse movement of piping.

"H" Section Only

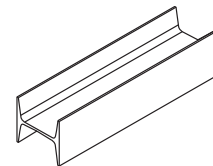

Options (for all types)

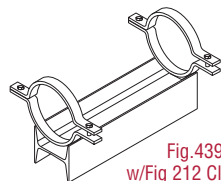

Fig. 439
w/ Fig 212 Clamps

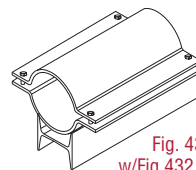

Fig. 439
w/ Fig 432 Clamp

Fig. 432

Special Clamp

Size Range: 2" through 24"

Material: Carbon steel

Finish: Plain or Galvanized

Maximum Temperature: Plain 750° F, Galvanized 450° F
for carbon steel pipe only

Service: Used with and where pipe slides cannot be welded directly to pipe or copper tube. When used with fiberglass, plastic, or aluminum pipe, a thin protective liner should be inserted between the pipe and the clamp. Clamp is designed for use with Figure 257 and Figures 436 and 439 slides and tees.

Ordering: Specify figure number, pipe size, name and finish.

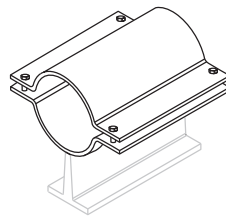

Fig. 257
w/ Fig 432 Clamp

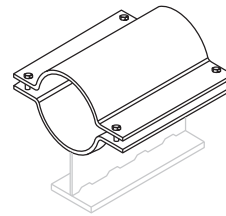

Fig. 436
w/ Fig 432 Clamp

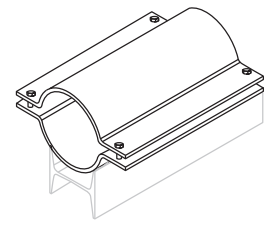

Fig. 439
w/ Fig 432 Clamp

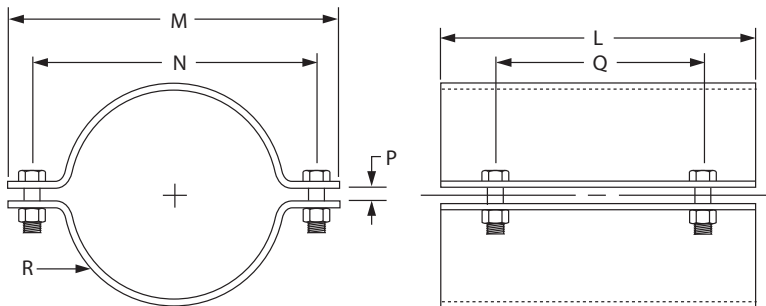

FIG. 432: WEIGHT (LBS) • DIMENSIONS (IN)

Pipe Size	L	M	N	P	Q	R Stock Size	Weight
2	6	5	4	1/4	4 1/2	1/8 x 6	2
2 1/2		5 1/2	4 1/2				3
3		6	5				3
3 1/2		6 1/2	5 1/2				4
4		7	6				4
5	8	8	7	3/8	6	3/16 x 8	5
6		9 5/8	8 1/2				12
8		11 5/8	10 1/2				15
10		13 3/4	12 5/8				18
12		15 3/4	14 5/8				21
14	12	17 7/8	16 1/2	1/2	8	1/4 x 12	41
16		19 7/8	18 1/2				46
18		21 7/8	20 1/2				52
20		23 7/8	22 1/2				57
24		28 1/8	26 7/8				67

Fig. 212

Medium Pipe Clamp

Size Range: 2" through 30"

Material: Carbon steel

Finish: Plain or Galvanized

Maximum Temperature: Plain 750° F, Galvanized 450° F

Service: Pipe clamp for figure numbers 257, 436, and 439 slides and tees.

Ordering: Specify pipe size, figure number, name and finish.

Note: Two clamps are required. "T" section 257/436 or "H" section 439 are notched to accommodate clamps and to eliminate the increase in height of the slide assembly.

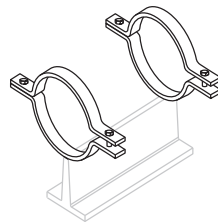
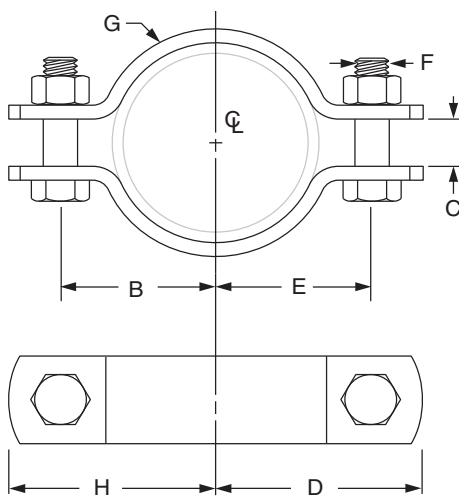

Fig. 257
w/ Fig 212 Clamps

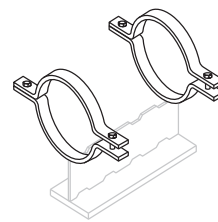

Fig. 436
w/ Fig 212 Clamps

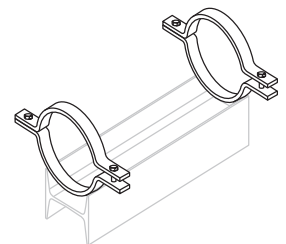

Fig. 439
w/ Fig 212 Clamps

FIG. 212: WEIGHT (LBS) • DIMENSIONS (IN)

Pipe Size	B	C	D	E	H	F	G Width	Weight
2	2 $\frac{1}{8}$	$\frac{1}{2}$	2 $\frac{3}{4}$	2 $\frac{1}{8}$	2 $\frac{3}{4}$	$\frac{1}{2}$	1	2.2
2 $\frac{1}{2}$	2 $\frac{5}{8}$	$\frac{5}{8}$	3 $\frac{1}{4}$	2 $\frac{5}{8}$	3 $\frac{1}{4}$			2.4
3	2 $\frac{7}{8}$		3 $\frac{1}{2}$	2 $\frac{7}{8}$	3 $\frac{1}{2}$			2.8
3 $\frac{1}{2}$	3 $\frac{3}{16}$		3 $\frac{13}{16}$	3 $\frac{3}{16}$	3 $\frac{13}{16}$			3.0
4	3 $\frac{1}{2}$	$\frac{3}{4}$	4 $\frac{1}{4}$	3 $\frac{1}{2}$	4 $\frac{1}{4}$	$\frac{5}{8}$	1 $\frac{1}{4}$	4.6
5	4 $\frac{3}{16}$		4 $\frac{15}{16}$	4 $\frac{3}{16}$	4 $\frac{15}{16}$			5.2
6	4 $\frac{7}{8}$		5 $\frac{3}{4}$	4 $\frac{7}{8}$	5 $\frac{3}{4}$	$\frac{3}{4}$	1 $\frac{1}{2}$	10.8
8	6	6 $\frac{7}{8}$	6	6 $\frac{7}{8}$	13.0			
10	7 $\frac{7}{16}$	1	8 $\frac{9}{16}$	7 $\frac{7}{16}$	8 $\frac{9}{16}$	$\frac{7}{8}$	2	27.2
12	8 $\frac{7}{16}$		9 $\frac{9}{16}$	8 $\frac{7}{16}$	9 $\frac{9}{16}$			30.4
14	9 $\frac{1}{4}$	1 $\frac{1}{8}$	10 $\frac{5}{8}$	9 $\frac{1}{4}$	10 $\frac{5}{8}$		2 $\frac{1}{2}$	41.0
16	10 $\frac{1}{4}$		11 $\frac{5}{8}$	10 $\frac{1}{4}$	11 $\frac{5}{8}$			44.6
18	11 $\frac{5}{8}$	1 $\frac{1}{4}$	13	11 $\frac{5}{8}$	13	1	63.2	
20	12 $\frac{3}{4}$	1 $\frac{3}{8}$	14 $\frac{1}{8}$	12 $\frac{3}{4}$	14 $\frac{1}{8}$	1 $\frac{1}{8}$	71.6	
24	15 $\frac{1}{4}$	1 $\frac{5}{8}$	16 $\frac{7}{8}$	15 $\frac{1}{4}$	16 $\frac{7}{8}$	1 $\frac{1}{4}$	3	106.2
30	19	2	21 $\frac{1}{8}$	19	21 $\frac{1}{8}$	1 $\frac{3}{4}$	4	227.8

•Clamps may be furnished with square ends.

SPRING HANGERS

Fig. 82, Fig. B-268, Fig. 98, Triple Spring, and Quadruple Spring Fig. C-82, Fig. C-268, Fig. C-98, Triple-CR, and Quadruple-CR Spring (Corrosion Resistant)

Design features:

- Precompression.
Precompressing the spring into the hanger casing provides the following advantages:
 - (1) Saves up to 50% in headroom by reducing the length of the hanger.
 - (2) Reduces the installed height of the overall hanger assembly.
 - (3) Prevents the spring supporting force from exceeding the normal safe limits of variations.
 - (4) Saves valuable erection time because spring is precompressed close to $\frac{1}{2}$ " of the working range.
- Calibration: all Anvil Variable Spring Hangers and supports are calibrated for accurate loading conditions.
- Load indicator is clearly seen in the slot, simplifying reading of the scale plate. Load is read from bottom of indicator.
- Cold set at the factory upon request.
- Spring and casing are fabricated of steel and are rugged and compact.
- Piston cap serves as a centering device or guide maintaining spring alignment.
- Casing protects the spring from damage and weather conditions.

Standard Finish: Painted with semi-gloss primer.

Corrosion Resistant: Anvil offers corrosion-resistant and weather-resistant Variable Spring Hangers to fill vital needs in the chemical and refinery industries as well as in modern outdoor power plant construction. For protection against severe weather conditions or moderate corrosive conditions, the parts of the hanger are galvanized per ASTM A-153, except the spring which has a protective coating and the load column for Type F which is electro-galvanized.

Advantages of a Protective Coating:

- Protects from a wide range of corrosives.
- Does not affect the flex life of the spring.
- Recommended for ambient temperatures up to 200° F

Travel stop: The functional design of the pre-compressed variable spring hanger permits the incorporation of a two-piece travel stop that locks the hanger spring against upward or downward movement for temporary conditions of underload or overload. The complete travel stop, the up travel stop only for cold set purposes or the down travel stop only which may be employed during erection, hydrostatic test (Anvil permits a hydrostatic test load of 2 times the normal operating load for the spring hanger) or chemical cleanout will be furnished only when specified. The travel stop is painted red and is installed at the factory with a caution tag attached calling attention that the device must be removed before the pipe line is put in service. Permanently attached travel stops available upon request.

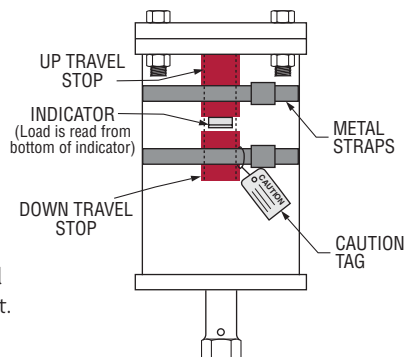

Approvals: WW-H-171E (Types 51, 56 and 57), ANSI/MSS SP-69 and MSS SP-58 (Types 51, 52 and 53).

Specifications: Anvil Variable Spring Hangers are welded in strict accordance with ASME Section IX.

Size Range: The Anvil Variable Spring Hanger in five series and seven types is offered in twenty-three sizes (Fig. B-268 only is offered in twenty-five sizes). The hanger can be furnished to take loads 10 lbs. to 50,000 lbs.

Ordering:

- (1) Size
- (2) Type
- (3) Figure number
- (4) Product name
- (5) Desired supporting force in operating position
- (6) Calculated amount and direction of pipe movement from installed to operating position.
- (7) Customer's identification number (if any)
- (8) When ordering Type F spring specify if roller or guided load column is to be furnished.
- (9) When ordering Type G, specify total load and load per spring plus center to center rod dimensions.
- (10) If required, specify with travel stop
- (11) When ordering corrosion resistant, specify C-268, C-82, C-98, Triple-CR, or Quadruple-CR "completely galvanized except coated spring coil".

Note:

To help alleviate the problem of lifting large size spring hangers into position for installation, this product is available with lifting lugs (if required) on sizes weighing one hundred pounds or more.

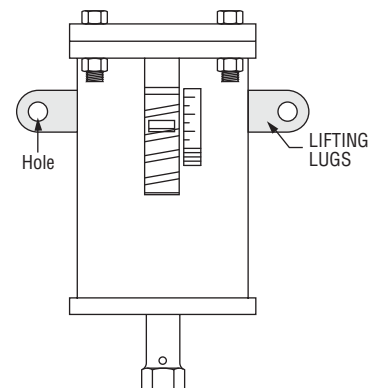
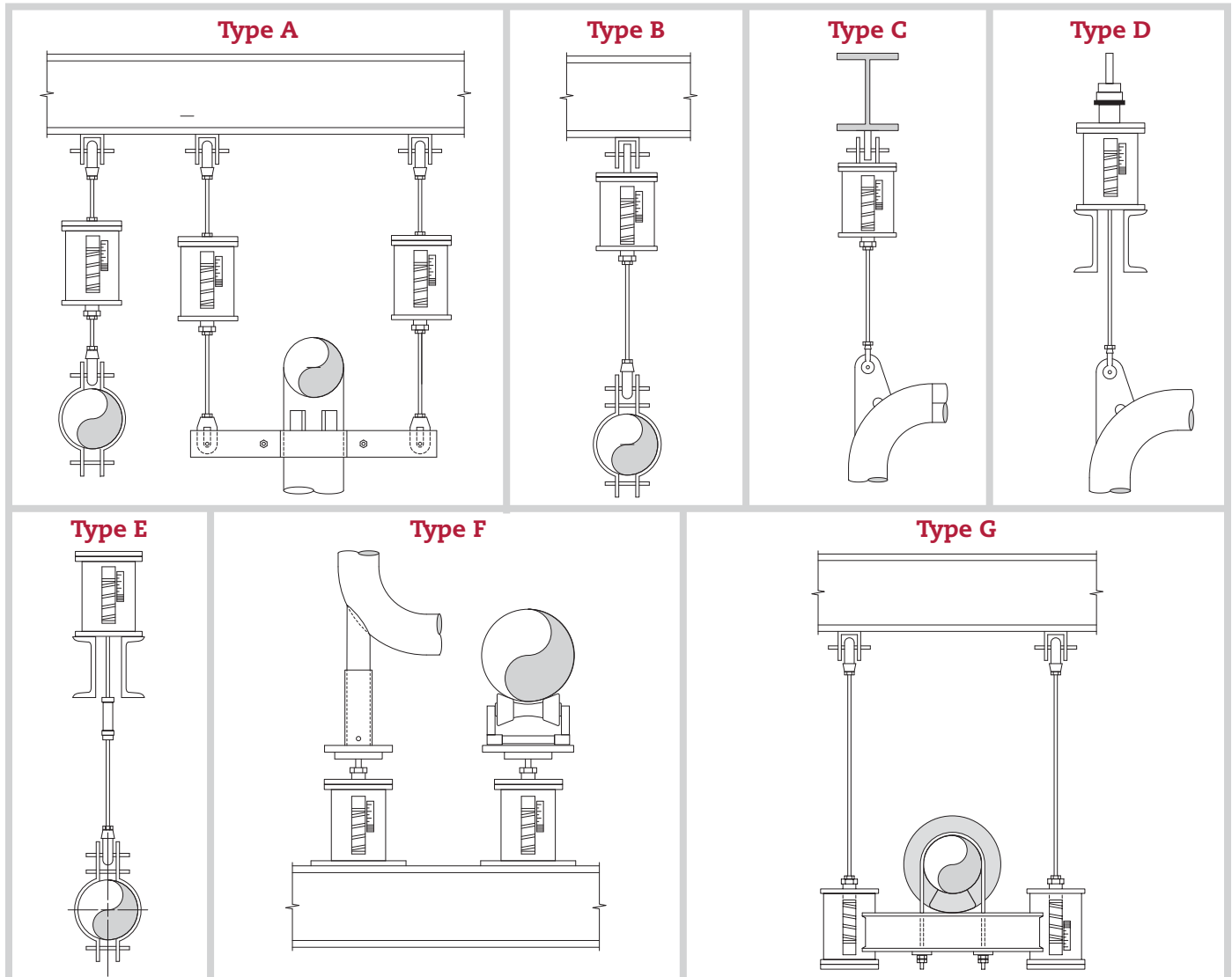

**Fig. 82, Fig. B-268, Fig. 98, Triple Spring, and Quadruple Spring (cont.)
Fig. C-82, Fig. C-268, Fig. C-98, Triple-CR, and Quadruple-CR Spring (Corrosion Resistant)**

How to Determine Type: The type of variable spring hanger to be used depends upon the physical characteristics required by the suspension problem (e.g., amount of head room, whether pipe is to be supported above or below the spring, etc.).

Consideration should be given to the seven standard types offered (see illustration below). Special variable spring hangers can be fabricated for unusual conditions.

Spring Hanger Types – Typical Applications



Recommended Service: Pipe hangers located at points that are subject to vertical thermal movement and for which a constant support hanger is not required (see “recommended service” for constant support hanger, page 161). Type D & E spring hangers may accommodate less than 4° of rod swing depending on size, figure number, and application.

Installation: Securely attach hanger to the building. Attach lower hanger rod and turn the load coupling until the load indicator is positioned at the desired setting indicated on the load scale plate.

Adjustment of Hanger: Once installed in the line; the hanger should be adjusted until the load indicator moves to the white button marked “C” (cold position). On inspection of the system, after a reasonable period of operation, the load indicator should be at the red button marked “H” (hot position). If it is not, the hanger should be readjusted to the hot position. No other adjustment is necessary.

How to Determine Series: Complete sizing information is given on the hanger selection chart on pages 144 and 145. The sizing information is applicable to hangers of all series. As noted on the hanger selection charts that the total spring deflection in the casing leaves a reserve (overtravel) above and below the recommended working load range.

SPRING HANGERS

Spring Hanger Size and Series Selection

How to use hanger selection table: In order to choose a proper size hanger, it is necessary to know the actual load which the spring is to support and the amount and direction of the pipe line movement from the cold to the hot position.

Find the actual load of the pipe in the load table. As it is desirable to support the actual weight of the pipe when the line is hot, the actual load is the hot load. To determine the cold load, read the spring scale, up or down, for the amount of expected movement.

The chart must be read opposite from the direction of the pipe's movement. The load arrived at is the cold load.

If the cold load falls outside of the working load range of the hanger selected, relocate the actual or hot load in the adjacent column and find the cold load. When the hot and cold loads are both within the working range of a hanger, the size number of that hanger will be found at the top of the column.

LOAD TABLE (LBS) FOR SELECTION OF HANGER SIZE (sizes 10 through 22 on next page)																	
Working Range (in) unshaded Shaded Rows Show Overtravel					Hanger size												
					B-268 Only		Fig. 82, Fig. B-268, Fig. 98, Triple & Quadruple Spring										
Figure No.					000	00	0	1	2	3	4	5	6	7	8	9	
Quad.	Triple	98	B-268	82													
2	1½	1	½	¼	7	19	43	63	81	105	141	189	252	336	450	600	
					7	20	44	66	84	109	147	197	263	350	469	625	
					8	22	46	68	88	114	153	206	273	364	488	650	
					9	24	48	71	91	118	159	213	284	378	506	675	
0	0	0	0	0	10	26	50	74	95	123	165	221	294	392	525	700	
					11	28	52	76	98	127	170	228	305	406	544	725	
					12	30	54	79	101	131	176	236	315	420	563	750	
					12	31	56	81	105	136	182	244	326	434	581	775	
2	1½	1	½	¼	14	34	58	84	108	140	188	252	336	448	600	800	
					14	35	59	87	111	144	194	260	347	462	619	825	
					15	38	61	89	115	149	200	268	357	476	638	850	
					16	40	63	92	118	153	206	276	368	490	656	875	
4	3	2	1	½	17	41	65	95	122	158	212	284	378	504	675	900	
					18	43	67	97	125	162	217	291	389	518	694	925	
					19	45	69	100	128	166	223	299	399	532	713	950	
					20	47	71	102	132	171	229	307	410	546	731	975	
6	4½	3	1½	¾	21	49	73	105	135	175	235	315	420	560	750	1,000	
					21	50	74	108	138	179	241	323	431	574	769	1,025	
					22	53	76	110	142	184	247	331	441	588	788	1,050	
					23	55	78	113	145	188	253	339	452	602	806	1,075	
8	6	4	2	1	24	56	80	116	149	193	258	347	462	616	825	1,100	
					25	58	82	118	152	197	264	354	473	630	844	1,125	
					26	60	84	121	155	201	270	362	483	644	863	1,150	
					27	62	86	123	159	206	276	370	494	658	881	1,175	
10	7½	5	2½	1¼	28	64	88	126	162	210	282	378	504	672	900	1,200	
					28	66	89	129	165	214	288	386	515	686	919	1,225	
					29	68	91	131	169	219	294	394	525	700	938	1,250	
					30	70	93	134	172	223	300	402	536	714	956	1,275	
2	1½	1	½	¼	31	72	95	137	176	228	306	410	546	728	975	1,300	
					Spring Rate (lbs/in)												
					82	–	–	30	42	54	70	94	126	168	224	300	400
					B-268	7	15	15	21	27	35	47	63	84	112	150	200
98	–	–	7	10	13	17	23	31	42	56	75	100					
Triple	–	–	5	7	9	12	16	21	28	37	50	67					
Quadruple	–	–	4	5	7	9	12	16	21	28	38	50					

Note: General rule for series selection use Fig. 82 for up to ½" of movement up to 1" use Fig. B-268, up to 2" use Fig. 98, up to 3" use a Triple, up to 4" use a Quadruple. Double check to assure desired variability is achieved.

Spring Hanger Size and Series Selection

How to use hanger selection table (cont.): Should it be impossible to select a hanger in a particular series such that both loads occur within the working range, consideration should be given to a variable spring hanger with a wider working range or a constant support hanger. The cold load is calculated by adding (for up movement) or subtracting (for down movement) the product of spring rate times movement to or from the hot load.

Cold load = (hot load) ± (movement) x (spring rate)

A key criteria in selecting the size and series of a variable spring is a factor known as variability. This is a measurement of the percentage change in supporting force between the hot and cold positions of a spring and is calculated from the formula:

Variability = (Movement) x (Spring Rate) / (Hot Load)

If an allowable variability is not specified, good practice would be to use 25% as recommended by MSS-SP-58.

LOAD TABLE (LBS) FOR SELECTION OF HANGER SIZE (Continued from previous page)																	
Hanger size													Working Range (in) unshaded Shaded Rows Show Overtravel				
Fig. 82, Fig. B-268, Fig. 98, Triple & Quadruple Spring													Figure No.				
10	11	12	13	14	15	16	17	18	19	20	21	22	82	B-268	98	Triple	Quad.
780	1,020	1,350	1,800	2,400	3,240	4,500	6,000	7,990	10,610	14,100	18,750	25,005					
813	1,063	1,406	1,875	2,500	3,375	4,688	6,250	8,322	11,053	14,588	19,531	26,047	¼	½	1	1½	2
845	1,105	1,463	1,950	2,600	3,510	4,875	6,500	8,655	11,495	15,275	20,313	27,089					
878	1,148	1,519	2,025	2,700	3,645	5,063	6,750	8,987	11,938	15,863	21,094	28,131					
910	1,190	1,575	2,100	2,800	3,780	5,250	7,000	9,320	12,380	16,450	21,875	29,173	0	0	0	0	0
943	1,233	1,631	2,175	2,900	3,915	5,438	7,250	9,652	12,823	17,038	22,656	30,215					
975	1,275	1,688	2,250	3,000	4,050	5,625	7,500	9,985	13,265	17,625	23,438	31,256					
1,008	1,318	1,744	2,325	3,100	4,185	5,813	7,750	10,317	13,708	18,213	24,219	32,298					
1,040	1,360	1,800	2,400	3,200	4,320	6,000	8,000	10,650	14,150	18,800	25,000	33,340	¼	½	1	1½	2
1,073	1,403	1,856	2,475	3,300	4,455	6,188	8,250	10,982	14,592	19,388	25,781	34,382					
1,105	1,445	1,913	2,550	3,400	4,590	6,375	8,500	11,315	15,035	19,975	26,563	35,424					
1,138	1,488	1,969	2,625	3,500	4,725	6,563	8,750	11,647	15,477	20,563	27,344	36,466					
1,170	1,530	2,025	2,700	3,600	4,860	6,750	9,000	11,980	15,920	21,150	28,125	37,508	½	1	2	3	4
1,203	1,573	2,081	2,775	3,700	4,995	6,938	9,250	12,312	16,362	21,738	28,906	38,549					
1,235	1,615	2,138	2,850	3,800	5,130	7,125	9,500	12,645	16,805	22,325	29,688	39,591					
1,268	1,658	2,194	2,925	3,900	5,265	7,313	9,750	12,977	17,247	22,913	30,469	40,633					
1,300	1,700	2,250	3,000	4,000	5,400	7,500	10,000	13,310	17,690	23,500	31,250	41,675	¾	1½	3	4½	6
1,333	1,743	2,306	3,075	4,100	5,535	7,688	10,250	13,642	18,132	24,088	32,031	42,717					
1,365	1,785	2,363	3,150	4,200	5,670	7,875	10,500	13,975	18,575	24,675	32,813	43,759					
1,398	1,828	2,419	3,225	4,300	5,805	8,063	10,750	14,307	19,017	25,263	33,594	44,801					
1,430	1,870	2,475	3,300	4,400	5,940	8,250	11,000	14,640	19,460	25,850	34,375	45,843	1	2	4	6	8
1,463	1,913	2,531	3,375	4,500	6,075	8,438	11,250	14,972	19,902	26,438	35,156	46,885					
1,495	1,955	2,588	3,450	4,600	6,210	8,625	11,500	15,305	20,345	27,025	35,938	47,926					
1,528	1,998	2,644	3,525	4,700	6,345	8,813	11,750	15,637	20,787	27,613	36,719	48,968					
1,560	2,040	2,700	3,600	4,800	6,480	9,000	12,000	15,970	21,230	28,200	37,500	50,010	1¼	2½	5	7½	10
1,593	2,083	2,756	3,675	4,900	6,615	9,188	12,250	16,302	21,672	28,788	38,281	51,052					
1,625	2,125	2,813	3,750	5,000	6,750	9,375	12,500	16,635	22,115	29,375	39,063	52,094	¼	½	1	1½	2
1,658	2,168	2,869	3,825	5,100	6,885	9,563	12,750	16,967	22,557	29,963	39,844	53,136					
1,690	2,210	2,925	3,900	5,200	7,020	9,750	13,000	17,300	23,000	30,550	40,625	54,178					
Spring Rate (lbs/in)																	
520	680	900	1,200	1,600	2,160	3,000	4,000	5,320	7,080	9,400	12,500	16,670	82				
260	340	450	600	800	1,080	1,500	2,000	2,660	3,540	4,700	6,250	8,335	B-268				
130	170	225	300	400	540	750	1,000	1,330	1,770	2,350	3,125	4,167	98				
87	113	150	200	267	360	500	667	887	1,180	1,567	2,083	2,778	Triple				
65	85	113	150	200	270	375	500	665	885	1,175	1,563	2,084	Quadruple				

Note: General rule for series selection use Fig. 82 for up to ½" of movement up to 1" use Fig. B-268, up to 2" use Fig. 98, up to 3" use a Triple, up to 4" use a Quadruple. Double check to assure desired variability is achieved.

Straps
Pipe Supports
Trapeze
Pipe Shields & Saddles
Pipe Roll
Pipe Guides & Slides
Spring Hangers
Constant Supports
Vibration Control & Sway Brace
Sway Strut Assembly
Snubbers
Special Design Products
Application Examples
Master Format 3 Part Specs.
Technical Data
Index

SPRING HANGERS

Variable Spring

Check List for Requesting a Quote or Ordering

Page ___ of ___



Anvil International
Precision Park
160 Frenchtown Rd.
North Kingstown, RI 02852

For technical information regarding
Variable Springs Call or Fax:
Fax Number: (401) 886-3056
Phone Number: (401) 886-3025

Finish: Standard Primer: _____ Galvanized: _____ Special Coating: _____

Quantity: _____

Figure No.: Options are: 82, B-268, 98, Triple, Quadruple
or: C-82, C-268, C-98, Triple-CR, Quadruple-CR

Size: Options are: #0 through #22 (B-268 / C-268 also available in #00 and #000) _____

Type: Options are: A through G* _____

Hot (Operating or Design) Load (lbs): _____ (optional)**

Cold/Installed (Factory Set) Load (lbs): _____ (optional)**

Vertical Movement: _____ + (up) or - (down) (optional)**

Mark Number: _____ (If Required)

Travel Stops: Yes: _____ No: _____

If travel stops are ordered and hot & cold loads are not provided, then the spring will be set to mid range load.

Lifting Lugs: Yes: _____ No: _____

Available on sizes weighing 100 lbs or more.

Notes:

* Type G Springs must also include the C-to-C dimension & the load per spring.

** Anvil will determine the appropriate Figure Number and will calculate the Cold Load when only the Hot Load and movement are specified.

Fig. B-268, C-268

Spring Hangers (Type A)

Type A is the basic unit of Fig. B-268 Anvil Variable Spring Hanger. It is designed for attachment to its supporting member by screwing a rod into a tapped hole in the top cap of the hanger the full depth of the top cap ("G" dimension). The upper jam nut should then be locked, securing the hanger. Adjustment of the hanger load is accomplished by turning the coupling on the lower hanger rod until the hanger picks up the load and the load indicator points to the desired position.

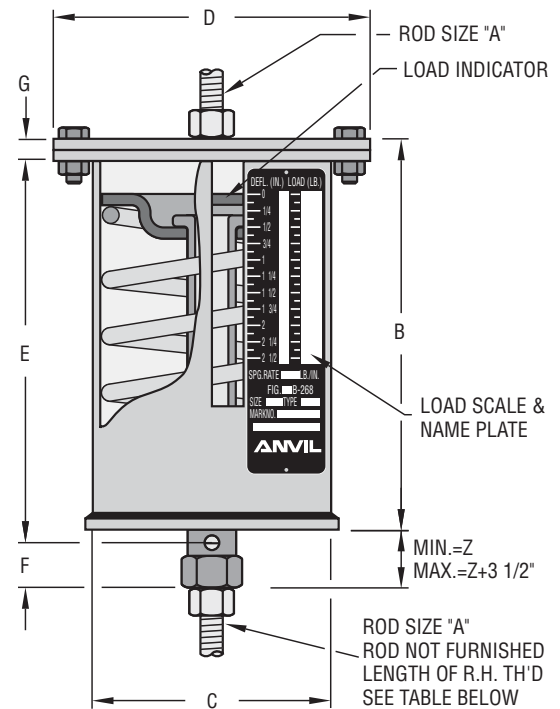

FIG. B-268, FIG. C-268 TYPE A: WEIGHT (LBS) • DIMENSIONS (IN)

Hanger Size	Weight	Rod Size A	R.H. Thread Length	Casing Length B	Casing Diam C	Flange Diam D	Rod Take Out E	Min. Thread Engagement F	Thread Depth G	Z
000	5	1/2	5	5 5/8	4	5 1/8	5 1/16	1 5/16	7/16	1 3/16
00	6			7 9/16			7 3/8			1 3/16
0	8	1/2	5	6 11/16	4	5 1/8	6 1/16	1 5/16	7/16	3/4
1	8			7 9/16			6 5/16			1
2	9	1/2	5	8 5/16	5 9/16	6 15/16	7 15/16	1 5/16	7/16	1
3	14			7 15/16			7 9/16			1
4	15	1/2	5	7 15/16	5 9/16	6 15/16	7 15/16	1 5/16	7/16	1 3/8
5	16			8 5/8			7 15/16			1 1/16
6	26	5/8	5	8 13/16	6 5/8	8 3/8	7 13/16	1 5/16	5/8	9/16
7	29			10			9 1/16			5/8
8	31	3/4	6	10 7/16	8 5/8	10 3/4	8 15/16	1 1/4	1	3/4
9	65			12 7/8			11 3/8			1 1/2
10	71	3/4	6	10 7/16	8 5/8	10 3/4	9 7/8	1 1/4	1	1 1/16
11	65			10 7/16			9 1/2			1 1/16
12	71	1	6	13 3/8	8 5/8	10 3/4	11 3/8	1 1/4	1	1/2
13	89			13 3/4			11 3/8			3/8
14	93	1 1/4	7	13 3/4	8 5/8	10 3/4	11 3/8	1 1/4	1 1/4	3/8
15	111	1 1/4		13 3/4			11 3/8			1 1/4
16	133	1 1/2	8	16 1/16	8 5/8	11 3/8	14 13/16	1 15/16	1 3/8	2 1/16
17	162	1 3/4		18 7/8			16 3/4			1 3/8
18	330	2	9	18 3/4	12 3/4	15 7/8	16	2 3/4	2 1/4	2 9/16
19	376	2 1/4		20 1/2			18 3/8			2 1/4
20	480	2 1/2	10	23 3/4	12 3/4	16 7/8	21 5/8	3 5/8	2 3/4	3 1/16
21	556	2 3/4		27 5/16			23 7/8			3 5/8
22	705	3	11	33 3/8	12 3/4	16 7/8	29 3/4	3 5/8	3	3 3/4

SPRING HANGERS

Fig. B-268, C-268

Spring Hangers (Type B & Type C)

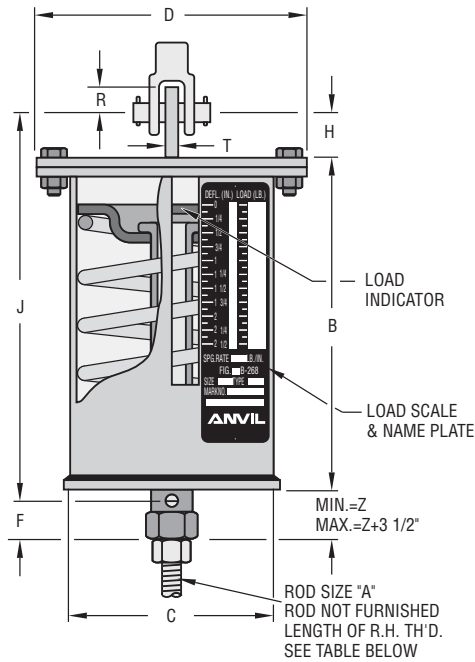

Fig. B-268 Type B

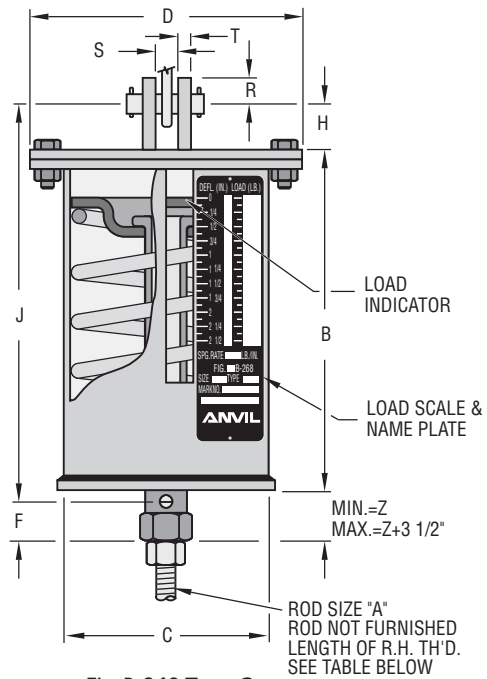

Fig. B-268 Type C

Type B is furnished with a single lug for attachment to the building structure. The lug permits use of a clevis, welded beam attachment or a pair of angles for attachment where headroom is limited.

Type C is furnished with two lugs for attachment to the building structure. These two lugs permit the use of an eye rod, Fig. 55L or a single plate for attachment where headroom is limited.

FIG. B-268, FIG. C-268 TYPE B, C: WEIGHT (LBS) • DIMENSIONS (IN)

Hanger Size	Weight (lbs)	Rod Size A	R.H. Thread Length	Lug Hole Size	Casing Length B	Casing Diam C	Flange Diam D	Min. Thd Engagement F	Height of Pin H	Rod Take Out J	R	Clevis Opening S	Thickness T	Z
000	5	1/2	5	1 1/16	5 5/8	4	5 5/8	1 5/16	1 1/2	7	1 1/4	7/8	1/4	1 3/16
00	6				7 7/16					9 1/2				1 3/16
0	8	1/2	5	1 1/16	6 11/16	4	5 5/8	1 5/16	1 1/2	8	1 1/4	7/8	1/4	3/4
1	9				7 9/16					8 5/16				1
2	10	1/2	5	1 1/16	7 15/16	5 5/16	6 15/16	1 5/16	1 1/2	9 1/2	1 1/4	7/8	1/4	1
3	14									9 7/8				1 1/16
4	16	1/2	5	1 1/16	8 5/8	5 5/16	6 15/16	1 5/16	1 1/2	9 15/16	1 1/4	7/8	1/4	1 3/8
5	17									11 1/16				1 1/16
6	27	5/8	5	1 3/16	8 13/16	6 5/8	8 3/8	1 5/16	1 1/2	11 1/16	1 1/4	1 1/16	1/4	9/16
7	30				10					5/8				
8	32	3/4	6	1 5/16	10 7/16	8 5/8	10 3/4	1 1/4	1 1/2	11 7/16	1 1/4	1 1/4	3/8	3/4
9	66				12 1/8					12 3/8				1 1/2
10	72	3/4	6	1 5/16	12 1/8	8 5/8	10 3/4	1 1/4	1 1/2	13 3/8	1 1/4	1 1/4	3/8	1 1/2
11	66				10 7/16					12 3/8				1 1/16
12	71	1	6	1 1/4	10 7/16	8 5/8	10 3/4	1 1/4	2	12 1/2	1 1/2	1 5/8	1/2	1 1/16
13	89				13 3/8					14 3/8				1/2
14	94	1 1/4	7	1 1/2	13 3/4	8 5/8	10 3/4	1 1/4	3	15 3/8	2	2	5/8	3/8
15	114	1 1/4			13 1/4					10 3/4				15 3/8
16	138	1 1/2	8	1 3/4	16 1/16	8 5/8	11 3/8	1 15/16	3	19 3/16	2 1/2	2 3/8	3/4	2 1/16
17	168	1 3/4			2					18 1/8				21 1/8
18	331	2	9	2 3/8	18 1/4	12 3/4	15 7/8	2 3/4	4	22 7/8	3	2 7/8	3/4	2 9/16
19	378	2 1/4			20 1/2					12 3/4				15 7/8
20	486	2 1/2	10	2 7/8	23 3/4	12 3/4	16 7/8	3 3/8	4 1/2	28 3/4	4	3 3/8	1	3 11/16
21	568	2 3/4			27 3/16					12 3/4				16 7/8
22	714	3	11	3 3/8	33 3/8	12 3/4	16 7/8	3 3/8	5	37 3/4	4	3 3/8	1	3 3/4

Fig. B-268, C-268

Spring Hangers (Type D & Type E)

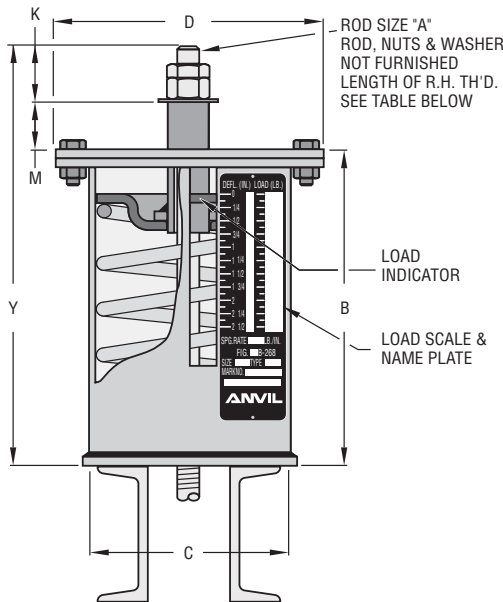

Fig. B-268 Type D

Type D permits adjustment of the hanger from the top. This type has a piece of tubing which passes through a hole in the top cap. Type D is especially adapted for use where the hanger is set above the supporting beams and pipe is suspended below.

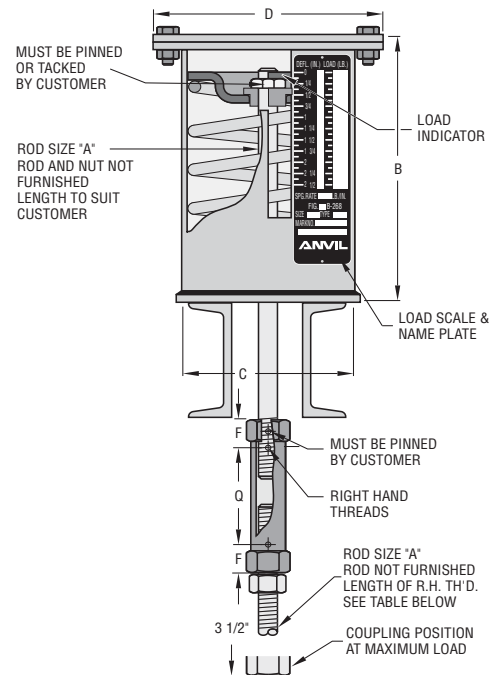

Fig. B-268 Type E

Type E is designed to permit adjustment from either above or below the hanger, when it is installed upon the supporting member and pipe is suspended below. A coupling tapped right hand both ends is furnished.

FIG. B-268, FIG. C-268 TYPE D, E: WEIGHT (LBS) • DIMENSIONS (IN)

Hanger Size	Weight (lbs)	Rod Size A	R.H. Thd Length	Casing Length B	Casing Diam C	Flange Diam D	Min Thread Engagement F	Allowance for Nuts K	Height of Spacer M	Rod Length Y	Rod Take-out Q		
000	5	1/2	5	5 5/8	4	5 1/8	1 3/16	1 1/4	3 3/8	10	6		
00	6			7 9/16						11 3/4			
0	6			6 11/16						11 1/16			
1	7	1/2	5	7 9/16	4	5 1/8	1 5/16	1 1/4	3 3/8	11 15/16	6		
2	8			8 5/16						12 11/16			
3	11			7 15/16						11 11/16			
4	12	1/2	5	8 5/8	5 9/16	6 15/16	1 5/16	1 1/4	3 3/8	12 5/16	6		
5	14			8 3/8						13			
6	22			8 3/16						13 5/16			
7	25	5/8	5	10	6 5/8	8 3/8	1 5/16	1 1/2	3	14 1/4	6		
8	26			14 3/4									
9	51			15 5/8									
10	58	3/4	6	10 7/16	8 5/8	10 3/4	1 1/4	1 3/4	3	16 7/8	6		
11	51			12 1/8						14 11/16			
12	56			10 7/16						15 13/16			
13	73	1	6	10 7/16	8 5/8	10 3/4	1 1/4	2 1/4	3	18 3/8	6		
14	77			13 3/8						19 1/4			
15	88			1 1/4						7		13 3/8	8 5/8
16	107	1 1/2	8	15 15/16	11 3/8	1 15/16	3 1/2	3	22 9/16				
17	133	1 3/4	9	18					12 3/4	15 7/8	2 3/4	4	
18	262	2	10	18 1/4									12 3/4
19	300	2 1/4	11	20 1/2	3	3	5 9/16	3					
20	370	2 1/2	10	23 3/4					3	3	6 1/4	3	
21	455	2 3/4	11	27 5/16									3
22	505	3	11	33 3/8	3	3	6 5/8	3					

SPRING HANGERS

Fig. B-268, C-268

Spring Hangers (Type F)

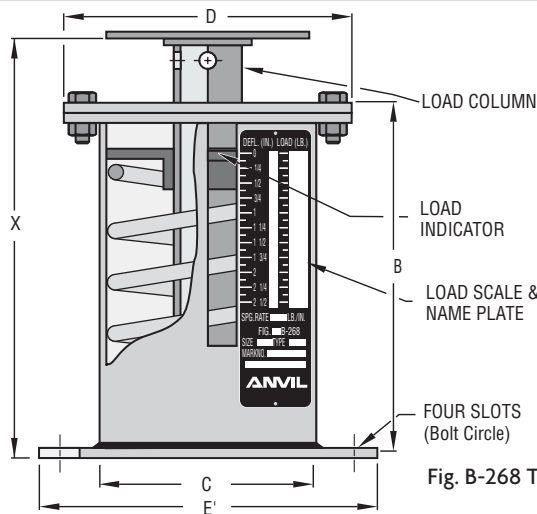
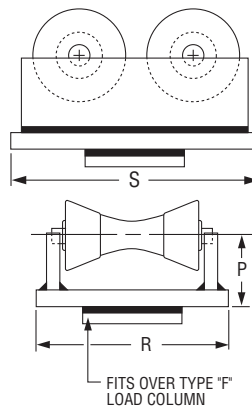

Fig. B-268 Type F



PIPE ROLL: DIMENSIONS (IN), LOAD (LBS)

Roll Size	Roll Mat'l	Max Load	P	R	S
2 - 3½	Cast Iron	780	1¼	4½	4½
4 - 6	Cast Iron	1,900	2⅝	5⅝	5½
8 - 10	Cast Iron	4,200	2¾	8¼	6¾
8 - 10	Steel	14,000	2¾	8¼	6¾
12 - 14	Cast Iron	6,150	3½	10⅝	6¾
12 - 14	Steel	26,000	3½	12	6¾
16 - 20	Cast Iron	9,960	3¾	12	6¾
16 - 20	Steel	34,000	3¾	12	6¾
24	Cast Iron	12,200	4	13¼	7
24	Steel	60,000	4	13¼	10
30	Cast Iron	15,000	4½	16½	8¼
30	Steel	60,000	5	16½	10
36	Cast Iron	24,000	4⅝	19	13
36	Steel	60,000	5	19	12

Type F is for use under a base elbow or piping that must be supported directly from the floor. If more than ¼" of horizontal translation occurs of loads resting on the flat load flange or other flat surface junction between the type F spring hanger and the load, a double roller design pipe roll is recommended. Pipe rolls, as illustrated above, will be furnished on request. For dimension of the pipe roll, refer to Fig. 271, see page 128.

Base type variable springs will be furnished with an extended load column on special order. Guided Load Columns and roller are available on request.

Adjustment to the required load rating is made by inserting a bar into holes provided in the load column and turning the column. The 2" increment between minimum and maximum "X" dimensions is the amount of field adjustment available and is in excess of the amount required for load adjustment.

FIG. B-268, FIG. C-268 TYPE F: WEIGHT (LBS) • DIMENSIONS (IN)

Hanger Size	Weight	Casing Length B	Casing Diam C	Flange Diam D	Bottom Flange Sq. E'	Bottom Flange Bolt Circle		Bottom Flange Bolts	Thickness Bottom Flange	Lengths - X*		Load Col. Diam	Load Flange Diam	Thickness of Load Flange	
						Min	Max			Min	Max				
000	11	5⅛	4	5⅝	7½	7	8¾	⅝	¼	7⅞	9⅞	1.9	3⅞	⅜	
00	12	7⅝								9⅞	11⅞				
0	12	6¾								8¼	10¼				
1	14	7⅝	4	5⅝	7½	7	8¾	⅝	¼	9⅞	11⅞	1.9	3⅞	⅜	
2	15	8⅝								9⅞	11⅞				
3	23	8								9⅞	11⅞				
4	25	8	5⅞	6⅝	7½	7	8¾	¾	¼	9⅞	11⅞	2.875	5⅞	⅜	
5	26									10¼	12¼				
6	40									10½	12½				
7	46	10⅞	6⅝	8⅝	9	8	10⅞	¾	⅝	11⅞	13⅞	3.5	6⅞	¼	
8	47									11⅞	13⅞				
9	91									12⅞	14⅞				
10	98	12¼	8⅝	10¾	13¼	10⅞	16½	¾	½	13⅞	15⅞	4.5	8⅞	½	
11	90									12⅞	14⅞				
12	95									12⅞	14⅞				
13	115	13¼	8⅝	10¾	13¼	10⅞	16½	¾	½	14⅞	16⅞	4.5	8⅞	½	
14	119									14⅞	16⅞				
15	130									14⅞	16⅞				
16	150	15⅝	8⅝	10¾	13¼	10⅞	16½	¾	½	17⅞	19⅞	2.0	8⅞	½	
17	173									18	20				22
18	343									18¼	20⅞				22⅞
19	380	20½	12¾	15⅞	17¼	15¼	22	¾	⅝	22⅞	24⅞	2.5	12½	½	
20	471									23¼	25⅞				27⅞
21	496									27⅞	29⅞				31⅞
22	654	33⅞	12¾	16⅞	17¼	15¼	22	¾	⅝	35½	37½	3.0	12½	½	

*Hanger take-out or installed height. With pipe movement up, cold to hot, installed height should be the mid-point between the minimum and maximum "X" dimension, plus thickness of load flange. With pipe movement down, cold to hot installed height should be mid-point between the minimum and maximum "X" dimension, plus the amount of vertical movement and load flange thickness. Note: Sizes 16" and larger are furnished with a hexagon nut at the top of a solid load column to facilitate adjustment with a wrench.

Fig. B-268, Fig. C-268

Spring Hangers (Type G)

Type G is a complete trapeze assembly. The hanger consists of two standard spring units plus a pair of back-to-back channels welded at each end to the hanger casing. The "P" dimension can be varied with the customer's instructions. In sizing a Type G hanger, it must be remembered that each standard spring unit carries one-half of the total pipe load. Therefore, in using the hanger selection chart, use one-half of the total pipe load as the hot load. When the pipe line is designed so as not to be centered on the channel, one spring of the trapeze will carry a heavier load, the other a lighter load. Care should be taken in calculating the load of each hanger and in choosing the proper sized spring in such cases. The center-to-center rod dimension must be specified when ordering.

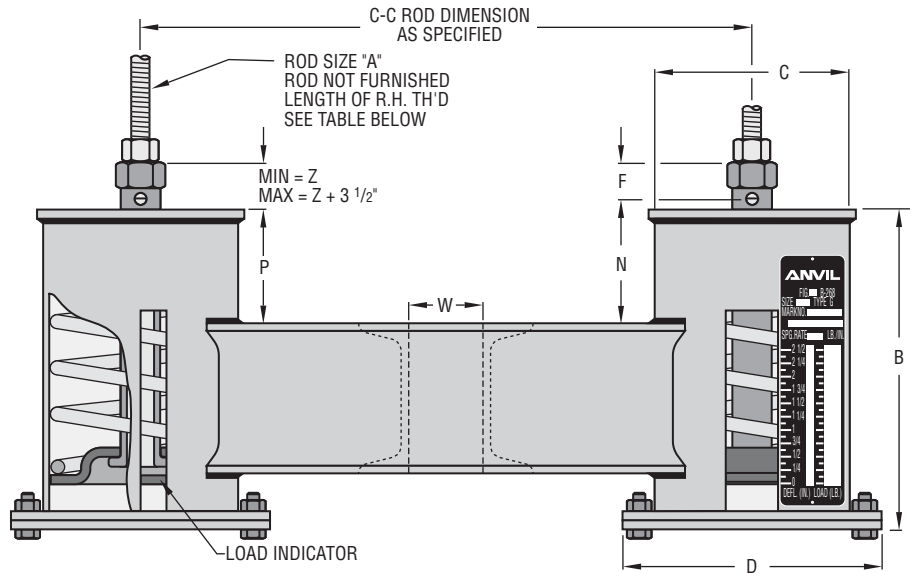

Fig. B-268 Type G

FIG. B-268, C-268 TYPE G: WEIGHT (LBS) • DIMENSIONS (IN)

Hanger Size	Weight*	Rod Size A	R.H. Thread Length	Casing Length B	Casing Dia. C	Flange Dia. D	Min Thread Engagement F	Rod Take Out N	Channel Size (lb/ft)	Max C-C	Space Between Channels W	P	Z
000	24	1/2	5	5 3/8	4	5 1/8	1 5/16	1 3/8	C3 x 4.1	24	5/8	1 1/2	1 3/16
00	26			7 9/16				1 3/4					1 3/16
0	30	1/2	5	6 11/16	4	5 1/8	1 5/16	1 5/16	C3 x 4.1	24	5/8	1 1/2	3/4
1	31			7 9/16				1 9/16					1
2	32			8 5/16				2 1/16					1
3	41	1/2	5	7 15/16	5 9/16	6 15/16	1 5/16	2 7/16	C3 x 4.1	30	3/4	2	1 13/8
4	42			8 5/8				1 3/4					1 1/16
5	43			8 5/8				1 3/4					1 1/16
6	63	5/8	5	8 13/16	6 5/8	8 3/8	1 5/16	1 5/8	C3 x 4.1	36	1	2	9/16
7	69			10				1 11/16					5/8
8	73	3/4	6	10 7/16	8 5/8	10 3/4	1 1/4	2 1/2	C4 x 5.4	36	1 1/4	3	3/4
9	143			12 1/8				3 3/4					1 1/2
10	157			10 7/16				3 7/16					1 11/16
11	145	1	6	10 7/16	8 5/8	10 3/4	1 1/4	3 13/16	C5 x 6.7	36	1 1/2	3	1 1/16
12	157			13 1/8				3 3/4					1 1/2
13	195	1 1/4	7	13 1/4	8 5/8	10 3/4	1 1/4	3 3/8	C6 x 10.5	33	1 1/2	3	3/8
14	203			13 1/4				3 3/8					1 1/2
15	250	1 1/2	8	16 1/16	8 5/8	11 3/8	1 15/16	4 1/8	C8 x 11.5	36	2 1/8	3	2 7/16
16	298			18 1/8				4					1 15/16
17	354	1 3/4	9	18 1/4	12 3/4	15 7/8	2 3/4	4	C12 x 20.7	42	2 5/8	3	2 9/16
18	690			20 1/2				4 1/8					2 11/16
19	783	2 1/2	10	23 3/4	12 3/4	16 7/8	3 5/8	4 1/8	C15 x 33.9	40	2 7/8	3	2 11/16
20	993			27 3/16				4 5/16					3 11/16
21	1,197	3	11	33 3/8	12 3/4	16 7/8	3 5/8	4 3/8	C15 x 33.9	48	3 1/8	3	3 11/16
22	1,496			33 3/8				4 3/8					3 3/8

*Weight based on 24" center-to-center dimension



Fig. 82, C-82

Short Spring Hangers

Fig. 82 Type A

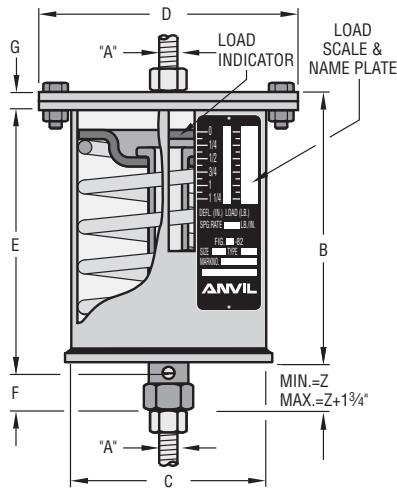

Fig. 82 Type B

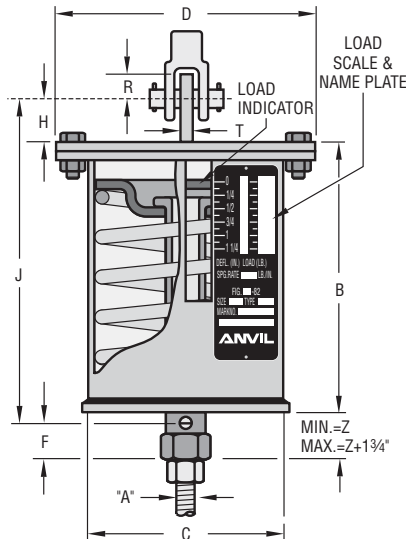

Fig. 82 Type C

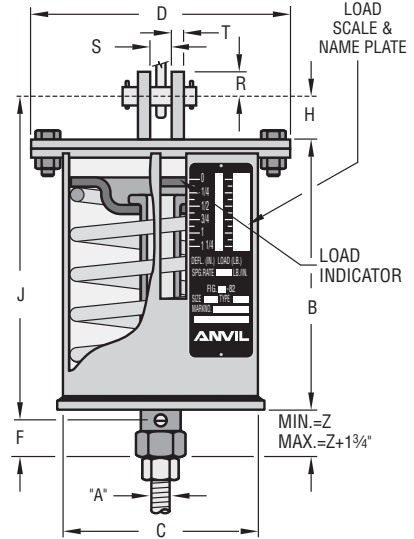

Fig. 82 Type D

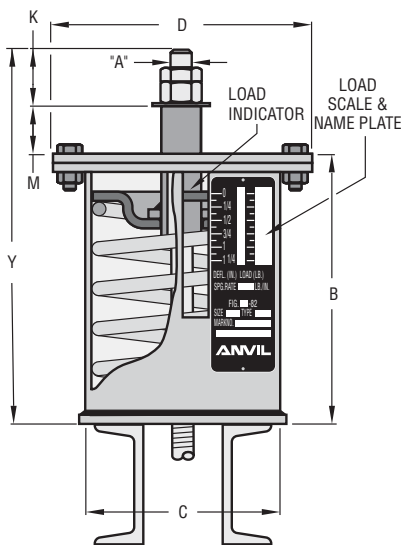

Fig. 82 Type E

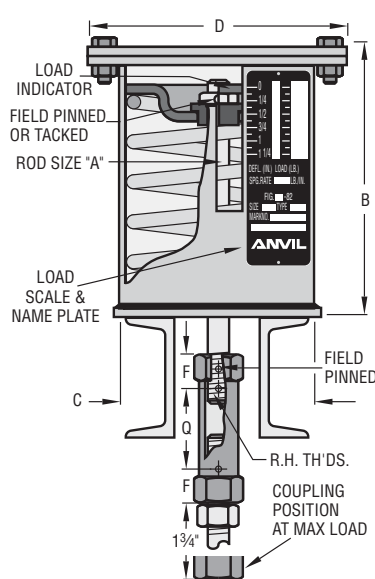

Fig. 82 Type F

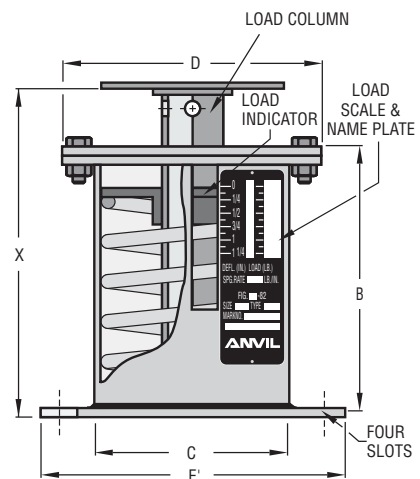
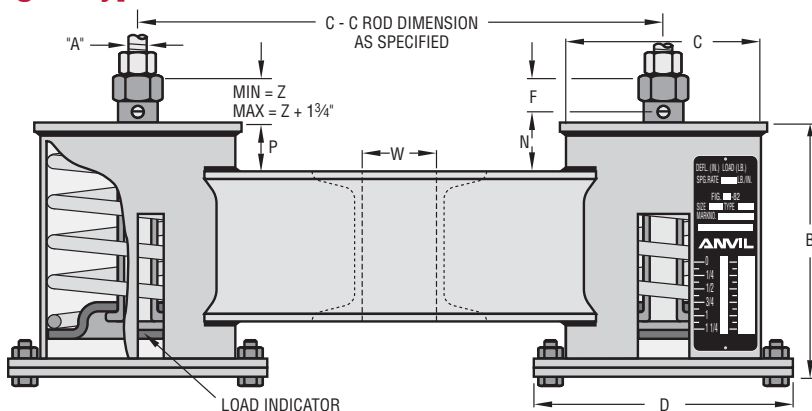

Fig. 82 Type G



The Anvil variable short spring hanger, Fig. 82, embodies all of the Fig. B-268 features and is designed to the same exacting specifications. This is useful in confined areas where thermal movement of the piping is relatively small. The minimum and maximum loads for the individual sizes of the Fig. 82 are exactly the same as those for the Fig. B-268. This hanger is offered in the seven basic types as shown here. The load table and instructions for sizing and ordering this hanger are found on page 142 through 145.

SPRING HANGERS

FIG. 82, C-82 SHORT SPRING: WEIGHT (LBS) • DIMENSIONS (IN)

Hanger Size	Rod Size A	R.H. Thread Length	Casing		Flange Dia. D	Min Thread Engage F	Z	Rod Take Out By Type				Type A Thread Depth G	Types B, C					Type D			
			Length B	Dia. C				A	B,C	E	G		Lug Hole Size	Pin Hgh H	R	Clevs Open-ing S	Thk. T	Rod Length Y	Nut Allow. K	Height Spacer M	
																					E
0							15/16	4 5/16	6 1/4		1							7 1/2			
1	1/2	3	4 3/4	4	5 1/8	15/16	1 1/16	4 1/16	6	2 1/8	3/4	7/16	1 1/16	1 1/2	1 1/4	7/8	1/4	7 3/4	1 1/4	1 3/4	
2			5 3/8				1 1/16	5 1/16	7		1 1/8							8 3/8			
3			5 1/4				9/16	4 7/16	6 3/8		5/8							7 7/8			
4	1/2	3	5 1/4	5 9/16	6 15/16	15/16	1 3/16	5 1/16	7	2 1/8	1 1/4	7/16	1 1/16	1 1/2	1 1/4	7/8	1/4	8 1/4	1 1/4	1 3/4	
5			5 3/8				1 1/16				1 1/8							8 5/8			
6			5 13/16				1 3/16	5 1/16	7 3/16		1 1/8							9 1/16			
7	5/8	3	6 1 1/16	6 5/8	8 3/8	15/16	1 1/16	6 3/16	8 5/16	2 1/8	2 1/8	5/8	1 3/16	1 1/2	1 1/4	1 1/16	1/4	9 11/16	1 1/2	1 3/4	
8							1 3/16	5 15/16	8 1/16		1 1/8							9 15/16			
9			7 1/4				1 1/8	6 1/8	8 5/8		1 1/8							11 1/4			
10	3/4	4	8 1/4	8 5/8	10 3/4	1 1/4	1 3/8	7 3/8	9 7/8	2	2 1/8	1	1 5/16	1 1/2	1 1/4	1 1/4	3/8	11 3/4	1 3/4	1 3/4	
11			7 1/4				1 3/16	6 3/16	8 11/16		1 15/16							10 7/16			
12			7 1/4				7/8	6 1/16	8 1 1/16		1 1/8							11 1/4			
13	1	4	8 3/4	8 5/8	10 3/4	1 1/4	1	7 3/8	10 3/8	2	2 3/4	1	1 1/4	2	1 1/2	1 5/8	1/2	12 5/8	2 1/4	1 3/4	
14	1 1/4		8 7/8				3/4	7 3/8	11 3/8		2 1/2		1 1/2	3	2	2	5/8	13 3/8	3		
15	1 1/4	4	8 7/8		10 3/4	1 1/4	3/4	7 3/8	11 3/8	2	2 1/2	1	1 1/2		2	2	5/8	14 1/8	3		
16	1 1/2	5	10 5/8	8 5/8	11 3/8	1 15/16	2	9 5/16	13 11/16	6	1 1/16	1 3/8	1 3/4	3	2 1/2	2 3/8	3/4	15 7/8	3 1/2	1 3/4	
17	1 3/4	6	11 1/8					10 9/16	14 15/16		2 1/16		2			2 5/8		17 5/8	4		
18	2	7	13				2 1/2	10 11/16	16 13/16		7/16		2 3/8	4	3	2 7/8	3/4	19 3/16	4 9/16		
19	2 1/4		14	12 3/4	15 7/8	2 3/4	2 3/16	11 3/4	18 3/8	6	1	2 1/4	2 5/8		4 1/2	3 1/8		20 5/8	5	1 3/4	
20	2 1/2	8	16 1/8				2 1/16	14	20 7/8		1 1/8		2 7/8			4	3 3/8	1	23 3/16	5 9/16	
21	2 3/4	9	18	12 3/4	16 7/8	3 5/8	2 3/4	13 5/8	20 7/8	7	3/8	2 3/4	3 1/8	4 1/2	4	3 5/8	1	25	6 1/4	1 1/4	
22	3	10	22 1/4					17 5/8	25 3/8		2 3/8	3	3 3/8	5	4	3 7/8		29 3/8	6 5/8	1 3/4	

Hanger Size	Type F										Type G				Weight			
	E' Bottom Flange		Bottom Flange		Load Col. Dia.	Load Flange	Length X ■		Channel Size (lbs/ft)	Max C-C	Space Between Channels - W	P	Type					
	Size Sq.	Bolt Circle		Bolts			Thick	Dia.					Thick	Min	Max	A,B,C	D,E	F
		Min	Max															
0													6	5	11	27		
1	7 1/2	7	8 3/4	5/8	1/4	1.900	3 7/8	3 1/16	6 5/16	6 13/16	C3 x 4.1	24	5/8	3/4	7	6	11	29
2									6 15/16	7 7/16					8	7	12	
3									6 7/8	7 7/8	C3 x 4.1	30	3/4	3/4	11	10	10	33
4	7 1/2	7	8 3/4	3/4	1/4	2.875	5 5/8	3 1/16	7	7 1/2					12	11	20	35
5									7 1/2	8					13	12	21	36
6									7 1/2	8					20	19	33	51
7	9	8	10 7/8	3/4	3/8	3.50	6 3/8	1/4	8 3/8	8 7/8	C3 x 4.1	36	1	3/4	23	22	35	57
8									8 3/8	8 7/8					24	23	36	59
9									8 15/16	9 15/16					56	52	78	125
10	13 1/4	10 1/16	16 1/2	3/4	1/2	4.50	8 3/8	1/2	9 15/16	10 15/16	C4 x 5.4	36	1 1/4	1	62	58	84	137
11									8 15/16	9 15/16					55	51	76	121
12									8 15/16	9 15/16					58	53	78	132
13	13 1/4	10 1/16	16 1/2	3/4	1/2	4.50	8 3/8	1/2	10 7/16	11 7/16	C5 x 6.7	36	1 1/2	1	69	63	81	154
14									10 9/16	11 9/16		33			72	55	91	159
15						4.50			10 9/16	11 9/16	C6 x 10.5		1 1/2		88	79	100	198
16	13 1/4	10 1/16	16 1/2	3/4	1/2	2.00	8 3/8	1/2	12 5/8	13 3/8	C8 x 11.5	36	2 1/8	1	102	91	112	230
17									13 3/8	14 3/8					120	105	126	266
18									15 1/16	16 1/16					259	226	270	
19	17 1/4	15 3/4	22	3/4	5/8	2.50	12 1/2	1/2	16 1/16	17 1/16					286	246	275	
20									18 3/16	19 3/16					350	302	344	
21									20 1/8	21 1/8					401	339	348	
22	17 1/4	15 3/4	22	3/4	5/8	3.00	12 1/2	1/2	24 3/8	25 3/8					490	431	443	

■ Hanger take-out or installed height. With pipe movement up, cold to hot, installed height should be the mid point between the minimum and maximum "X" dimension, plus thickness of load flange. With pipe movement down, cold to hot installed height should be mid-point between the minimum and maximum "X" dimension, plus the amount of vertical movement and load flange thickness. (Type F only).
 * Weight based on 24" center-to-center dimension. See page 150 for Type F roller and guided load column information.
 Attachment rods and nuts not furnished.



Fig. 98, C-98

Double Spring

Fig. 98 Type A

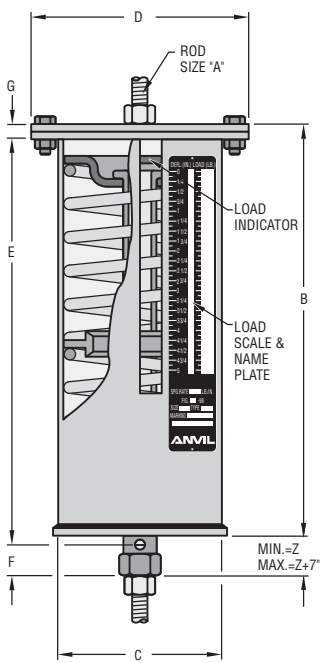

Fig. 98 Type B

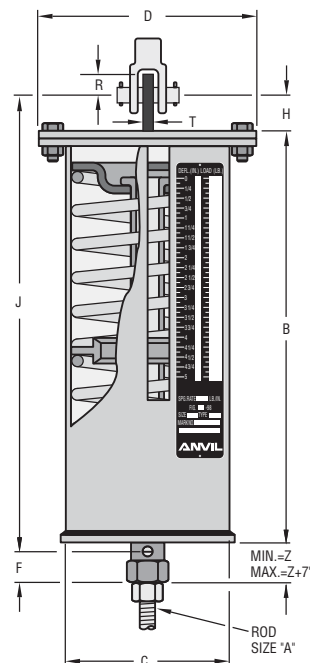

Fig. 98 Type C

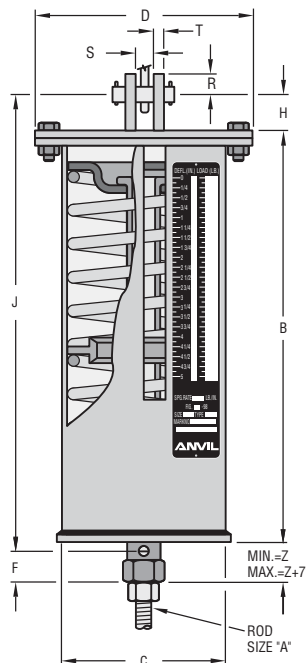

Fig. 98 Type D

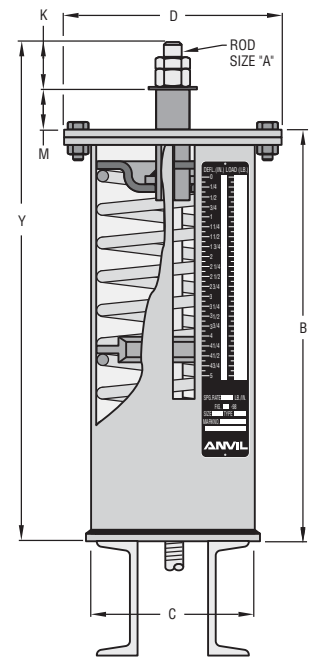

Fig. 98 Type E

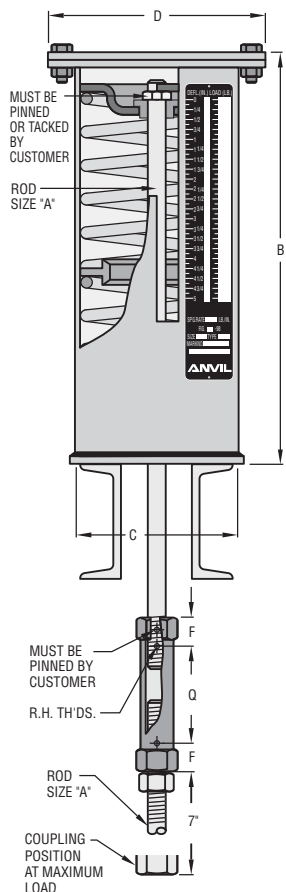

Fig. 98 Type F

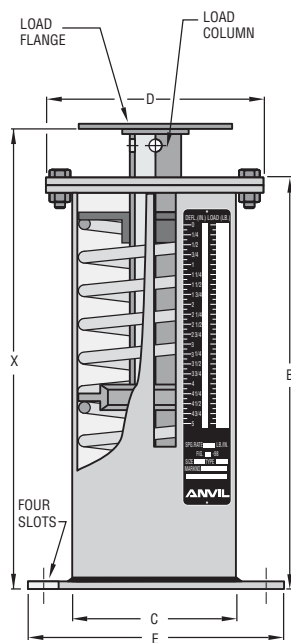
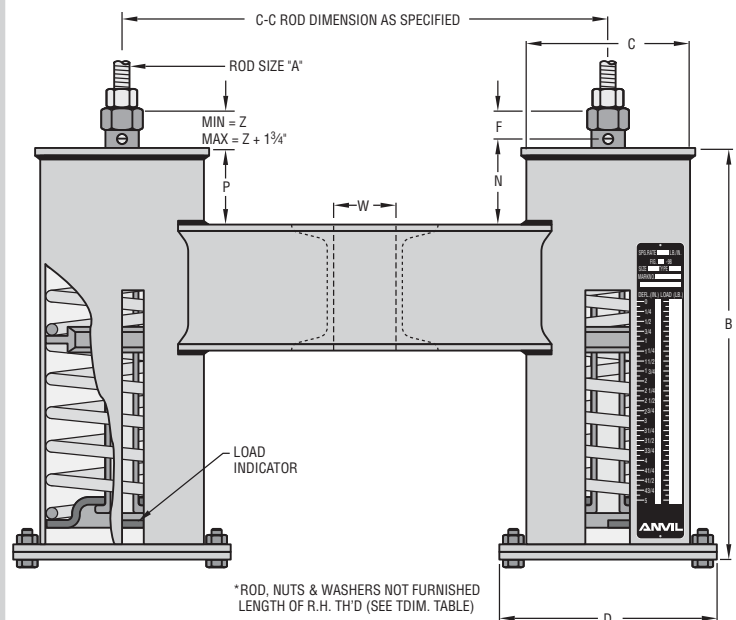

Fig. 98 Type G



The Anvil Variable Double Spring Hanger, Fig. 98, embodies all of the Fig. B-268 features and is designed to the same exacting specifications. Each basic unit consists of two springs arranged in series within a single casing. A centering guide is provided to assure the permanent alignment of the spring assembly. This hanger is offered in the seven basic types as shown here.

The load table and instructions for sizing and ordering this hanger may be found on page 142 through 145.

SPRING HANGERS

FIG. 98, C-98 DOUBLE SPRING: WEIGHT (LBS) • DIMENSIONS (IN)

Hanger Size	Rod Size A	R.H. Thread Length	Casing		Flange Dia. D	Min. Thread Engage F	Z	Rod Take Out By Type				Type A	Types B, C					Type D		
			Length B	Dia. C				A	B, C	E	G	Thread Depth G	Lug Hole Size	Pin Hgt H	R	Clevlis Opening S	Thk. T	Rod Length Y	Nut Allow. K	Height Spacer M
								E	J	Q	N									
0			12 ⁵ / ₈				1 ⁵ / ₁₆	12 ³ / ₁₆	14 ¹ / ₈		1 ¹ / ₂							19 ³ / ₈		
1	1/2	9	14 ³ / ₈	4	5 ¹ / ₈	1 ⁵ / ₁₆	1 ⁵ / ₁₆	13 ¹⁵ / ₁₆	15 ⁷ / ₈	9	1 ¹ / ₂	7/16	1 ¹ / ₁₆	1 ¹ / ₂	1 ¹ / ₄	7/8	1/4	21 ¹ / ₈	1 ¹ / ₄	5 ¹ / ₂
2			15 ⁷ / ₈				1 ¹ / ₁₆	15 ¹ / ₁₆	17 ¹ / ₈		1 ¹ / ₄							22 ¹ / ₂		
3			14				1 ³ / ₁₆	13 ⁷ / ₁₆	15 ³ / ₈		1 ⁷ / ₈							20 ³ / ₄		
4	1/2	9	15 ¹ / ₄	5 ⁹ / ₁₆	6 ¹⁵ / ₁₆	1 ⁵ / ₁₆	1 ³ / ₁₆	15 ³ / ₁₆	17 ⁷ / ₈	9	2 ³ / ₈	7/16	1 ¹ / ₁₆	1 ¹ / ₂	1 ¹ / ₄	7/8	1/4	22	1 ¹ / ₄	5 ¹ / ₂
5			16 ³ / ₈				1 ¹ / ₁₆	15 ¹⁵ / ₁₆	17 ⁷ / ₈		1 ³ / ₄							23 ³ / ₈		
6			16 ¹¹ / ₁₆				1 ³ / ₁₆	15 ¹⁵ / ₁₆	18 ¹ / ₁₆		1 ⁷ / ₈							23 ¹¹ / ₁₆		
7	5/8	9	18 ³ / ₈	6 ³ / ₈	8 ³ / ₈	1 ⁵ / ₁₆	1 ¹ / ₈	18 ³ / ₁₆	20 ³ / ₁₆	9	2 ³ / ₁₆	5/8	1 ³ / ₁₆	1 ¹ / ₂	1 ¹ / ₄	1 ¹ / ₁₆	1/4	25 ⁵ / ₈	1 ¹ / ₂	5 ¹ / ₂
8			19 ⁹ / ₁₆				1 ¹ / ₁₆	18 ¹ / ₁₆	20 ¹³ / ₁₆		1 ³ / ₄							26 ⁹ / ₁₆		
9			20 ³ / ₁₆				1 ⁵ / ₁₆	18 ⁷ / ₈	21 ³ / ₈		2 ¹¹ / ₁₆							27 ⁷ / ₁₆		
10	3/4	9	22 ⁵ / ₈	8 ⁵ / ₈	10 ³ / ₄	1 ¹ / ₄	1	21 ³ / ₈	23 ⁷ / ₈	9	2 ³ / ₄	1	1 ⁵ / ₁₆	1 ¹ / ₂	1 ¹ / ₄	1 ¹ / ₄	3/8	29 ⁷ / ₈	1 ³ / ₄	5 ¹ / ₂
11		10	18 ¹ / ₄				7/8	16 ⁷ / ₈	19 ³ / ₈	12	2 ⁵ / ₈							25 ¹ / ₂		
12			19 ¹ / ₂				5/8	17 ⁷ / ₈	20 ⁷ / ₈		3 ³ / ₈							27 ¹ / ₄		
13	1	10	24 ³ / ₄	8 ³ / ₈	10 ³ / ₄	1 ¹ / ₄	3/4	23 ¹ / ₄	26 ¹ / ₄	12	3 ¹ / ₂	1	1 ¹ / ₄	2	1 ¹ / ₂	1 ⁵ / ₈	1/2	32 ³ / ₈	2 ¹ / ₄	5 ¹ / ₂
14	1 ¹ / ₄		24 ⁷ / ₈				1/2	23 ³ / ₈	27 ¹ / ₈		3 ³ / ₄		1 ¹ / ₂	3	2	2	5/8	33 ³ / ₈	3	
15	1 ¹ / ₄	10	24 ⁷ / ₈		10 ³ / ₄		1/2	23 ³ / ₈	27 ¹ / ₈	12	3 ³ / ₄	1	1 ¹ / ₂		2	2	5/8	33 ³ / ₄	3	
16	1 ¹ / ₂	11	29 ³ / ₈	8 ³ / ₈		1 ¹⁵ / ₁₆	2	28 ⁹ / ₁₆	32 ¹⁵ / ₁₆	7	4 ¹ / ₁₆	1 ³ / ₈	1 ³ / ₄	3	2 ¹ / ₂	2 ³ / ₈	5/8	38 ⁷ / ₈	3 ¹ / ₂	5 ¹ / ₂
17	1 ³ / ₄	12	34		11 ³ / ₈		2 ¹ / ₈	32 ¹³ / ₁₆	37 ³ / ₁₆		4 ³ / ₁₆		2		2 ⁵ / ₈	3/4	43 ¹ / ₂	4		
18	2	12	33 ³ / ₄				2 ¹ / ₁₆	31 ¹ / ₈	37 ³ / ₁₆		4 ¹ / ₈		2 ³ / ₈	4	3	2 ⁷ / ₈	3/4	43 ³ / ₁₆	4 ⁹ / ₁₆	
19	2 ¹ / ₄	13	37 ³ / ₄	12 ³ / ₄	15 ⁵ / ₈	2 ³ / ₄	2 ⁹ / ₁₆	35 ¹ / ₂	42 ¹ / ₈	7	4	2 ¹ / ₄	2 ⁵ / ₈	4 ¹ / ₂	3	3 ¹ / ₈	3/4	48 ¹ / ₈	5	5 ¹ / ₂
20	2 ¹ / ₂	14	44 ¹ / ₄				2 ¹ / ₁₆	42 ¹ / ₈	48 ³ / ₄		4 ¹ / ₈		2 ⁷ / ₈		4	3 ⁵ / ₈	1	55 ³ / ₁₆	5 ⁹ / ₁₆	
21	2 ³ / ₄	14	49 ³ / ₈	12 ³ / ₄	16 ⁷ / ₈	3 ⁵ / ₈	2 ¹ / ₁₆	45 ¹ / ₁₆	52 ¹ / ₁₆	7	3 ⁵ / ₁₆	2 ³ / ₄	3 ¹ / ₈	4 ¹ / ₂	4	3 ⁵ / ₈	1	60 ⁵ / ₈	6 ¹ / ₄	5 ¹ / ₂
22	3	15	62				3 ¹ / ₂	58 ¹ / ₈	66 ¹ / ₈		4 ¹ / ₈	3	3 ³ / ₈	5		3 ⁵ / ₈	1	73 ¹ / ₈	6 ⁵ / ₈	

Hanger Size	Type F										Type G				Weight						
	E' Bottom Flange		Bottom Flange		Load Col. Dia.	Load Flange		Length X ■		Channel Size (lbs/ft)	Max C-C	Space Between Channels - W	P	Type							
	Size Sq.	Bolt Circle	Min	Max		Bolts	Thick	Dia.	Thick					Min	Max	A,B,C	D,E	F	G*		
0																		12	12	20	37
1	7 ¹ / ₂	7	8 ³ / ₄	5/8	1/4	1.90	3 ⁷ / ₈	3 ³ / ₁₆	14 ³ / ₁₆	16 ³ / ₁₆	C3 x 4.1	24	5/8	1 ¹ / ₂			14	14	21	41	
2									15 ¹⁵ / ₁₆	17 ¹⁵ / ₁₆							16	16	23	45	
3									17 ⁷ / ₁₆	19 ⁷ / ₁₆											
4	7 ¹ / ₂	7	8 ³ / ₄	3/4	1/4	2.88	5 ³ / ₄	3 ³ / ₁₆	15 ⁵ / ₈	17 ⁵ / ₈	C3 x 4.1	30	3/4	2			22	21	35	55	
5									16 ³ / ₈	18 ³ / ₈							25	24	39	61	
6									18 ¹ / ₄	20 ¹ / ₄							27	26	41	65	
7									18 ³ / ₈	20 ³ / ₈							41	40	62	93	
8	9	8	10 ⁷ / ₈	3/4	3/8	3.50	6 ³ / ₈	1/4	20 ⁵ / ₁₆	22 ⁵ / ₁₆	C3 x 4.1	36	1	2			49	48	72	109	
9									21 ¹ / ₄	23 ¹ / ₄							61	52	75	133	
10	13 ¹ / ₄	10 ¹ / ₁₆	16 ¹ / ₂	3/4	1/2	4.50	8 ³ / ₈	1/2	21 ⁷ / ₈	23 ³ / ₈							97	94	136	207	
11									24 ⁵ / ₁₆	26 ⁵ / ₁₆	C4 x 5.4	36	1 ¹ / ₄	3			114	108	150	241	
12									19 ¹⁵ / ₁₆	21 ¹⁵ / ₁₆							96	95	134	209	
13									21 ³ / ₁₆	23 ³ / ₁₆							108	104	144	223	
14	13 ¹ / ₄	10 ¹ / ₁₆	16 ¹ / ₂	3/4	1/2	4.50	8 ³ / ₈	1/2	26 ⁷ / ₁₆	28 ⁷ / ₁₆	C5 x 6.7	36	1 ¹ / ₂	4			144	139	181	305	
15						4.50			26 ³ / ₁₆	28 ³ / ₁₆		33					153	147	188	323	
16	13 ¹ / ₄	10 ¹ / ₁₆	16 ¹ / ₂	3/4	1/2	2.00	8 ³ / ₈	1/2	26 ⁹ / ₁₆	28 ⁹ / ₁₆	C6 x 10.5	36	1 ¹ / ₂	4			172	163	201	368	
17									31 ⁷ / ₈	33 ⁷ / ₈	C8 x 11.5	36	2 ¹ / ₈	4			218	202	241	462	
18									36	38							273	247	287	572	
19	17 ¹ / ₄	15 ³ / ₄	22	3/4	5/8	2.50	12 ¹ / ₂	1/2	35 ⁵ / ₁₆	37 ⁵ / ₁₆	C12 x 20.7	42	2 ³ / ₈	4			512	477	550	1,056	
20									39 ¹³ / ₁₆	41 ¹³ / ₁₆		40					600	548	624	1,231	
21									46 ⁵ / ₁₆	48 ⁵ / ₁₆							802	723	807	1,633	
22	17 ¹ / ₄	15 ³ / ₄	22	3/4	5/8	3.00	12 ¹ / ₂	1/2	51 ⁷ / ₈	53 ⁷ / ₈	C15 x 33.9	48	3 ³ / ₈	4			940	845	872	1,965	
									64	66			3 ⁵ / ₈	4			1,240	1,140	1,184	2,566	

■ Hanger take-out or installed height. With pipe movement up, cold to hot, installed height should be the mid point between the minimum and maximum "X" dimension, plus thickness of load flange. With pipe movement down, cold to hot installed height should be mid-point between the minimum and maximum "X" dimension, plus the amount of vertical movement and load flange thickness. (Type F only).

* Weight based on 24" center-to-center dimension. See page 150 for Type F roller and guided load column information. Attachment rods and nuts not furnished.



SPRING HANGERS

Triple Spring, Triple Spring-GR

Triple Type A

ROD SIZE "A"
LOAD INDICATOR
LOAD SCALE & NAME PLATE
MIN. = Z
MAX. = Z + 10 1/2"
ROD SIZE "A"

Triple Type B

LOAD INDICATOR
LOAD SCALE & NAME PLATE
MIN. = Z
MAX. = Z + 10 1/2"
ROD SIZE "A"

Triple Type C

LOAD INDICATOR
LOAD SCALE & NAME PLATE
MIN. = Z
MAX. = Z + 10 1/2"
ROD SIZE "A"

Triple Type D

ROD SIZE "A"
LOAD INDICATOR
LOAD SCALE & NAME PLATE
MIN. = Z
MAX. = Z + 10 1/2"
ROD SIZE "A"

Triple Type E

LOAD INDICATOR
LOAD SCALE & NAME PLATE
MUST BE PINNED OR TACKED BY CUSTOMER
ROD SIZE "A"
MIN. = Z
MAX. = Z + 3 1/2"

Triple Type F

LOAD FLANGE
LOAD INDICATOR
LOAD SCALE & NAME PLATE
FOUR SLOTS

Triple Type G

C-C ROD DIMENSION AS SPECIFIED
NOT TO EXCEED C-C MAX
ROD SIZE "A"
MIN = Z
MAX = Z + 3 1/2"
LOAD INDICATOR

The Anvil Variable Triple Spring Hanger embodies all of the Fig. B-268 features and is designed to the same exacting specifications. Each basic unit consists of three springs arranged in series within a single casing. A centering guide is provided to assure the permanent alignment of the spring assembly. This hanger is offered in the seven basic types as shown here.

The load table and instructions for sizing and ordering this hanger may be found on page 142 through 145.

Triple Spring, Triple Spring-GR

TRIPLE SPRING: DIMENSIONS (IN)																	
Hanger Size	General Dimensions						Rod Take Out For Types					Type A	Type D		Type F		Type G
	Rod Size A	R.H. Thread Length	Casing Length B	Casing Dia. C	Min Thread F	Z	A	B & C	D	E	G	Depth Thread G	K	M	Loaded Length Dim X		P
							E	J	Y	Q	N				Min	Max	
0	1/2	12	19 1/8	4	15/16	15/16	19 1/8	20 5/8	28 1/8	11 1/8	1 1/2	7/16	1 1/4	7 3/4	20 15/16	22 15/16	1 1/2
1			21 3/4				23 1/4	30 3/4	23 3/16						25 1/16	25 9/16	
2			24				25 1/2	33	25 13/16						27 9/16		
3	1/2	12	21 3/16	5 9/16	15/16	15/16	21 3/16	22 11/16	30 3/16	11 1/8	2	7/16	1 1/4	7 3/4	23	25	2
4			23 1/16				24 9/16	32 1/16	24 7/8						26 7/8		
5			25 1/8				26 5/8	34 1/8	26 15/16						28 15/16		
6	5/8	12	25	6 5/8	15/16	15/16	25	26 1/2	34 3/16	11 1/8	2	5/8	1 1/2	7 11/16	26 15/16	28 15/16	2
7			27 15/16				29 1/16	37 1/8	29 7/8						31 7/8		
8			29 5/16				30 13/16	38 1/2	31 1/4						33 1/4		
9	3/4	13	29 9/16	8 5/8	1 1/4	1 1/4	29 9/16	31 1/16	38 7/8	11 1/2	3	1	1 3/4	7 9/16	31 5/8	33 5/8	3
10			33 1/4				34 3/4	42 9/16	35 5/16						37 5/16		
11			26 11/16				28 3/16	36	28 3/4						30 3/4		
12	1	13	28 9/16	8 5/8	1 1/4	1 1/4	28 9/16	30 9/16	38 3/8	11 1/2	3 7/8	1	2 1/4	7 9/16	30 5/8	32 5/8	4
13			36 1/4				38 1/4	46 1/16	38 5/16						40 5/16		
14			36 3/4				39 3/8	47 5/16	38 13/16						40 13/16		
15	1 1/4	14	36 5/8	8 5/8	1 3/8	1 1/4	36 5/8	39 1/2	47 3/16	10 9/16	4	1 3/8	3	7 9/16	38 11/16	40 11/16	4
16	44 1/16		47 1/16				54 5/8	46 1/8	48 1/8								
17	50 1/4		53 1/4				61 5/16	52 5/16	54 5/16								
18	2	16	49 7/8	12 3/4	2 3/4	2 3/4	49 7/8	53 7/8	60 11/16	10 7/8	4	2 1/4	4 9/16	7	51 5/16	53 5/16	4
19	55 7/8		60 3/8				67 7/8	11 7/16	58 1/16	60 1/16							
20	65 5/8		70 7/8				78 3/16	11 15/16	67 13/16	69 13/16							
21	2 3/4	17	73 5/16	12 3/4	3 5/8	3 5/8	73 5/16	76 13/16	87 7/8	11	4	2 3/4	6 1/4	9 5/16	75 7/16	77 7/16	4
22	3		91 1/2				95 1/2	106 7/16	11 1/2	3					6 5/8	93 5/8	

Attachment rods and nuts not furnished.
See page 150 for Type F roller and guided load column information.

See Fig. B-268 for dimensions not listed

SPRING HANGERS

Quadruple Spring, Quadruple Spring-CR

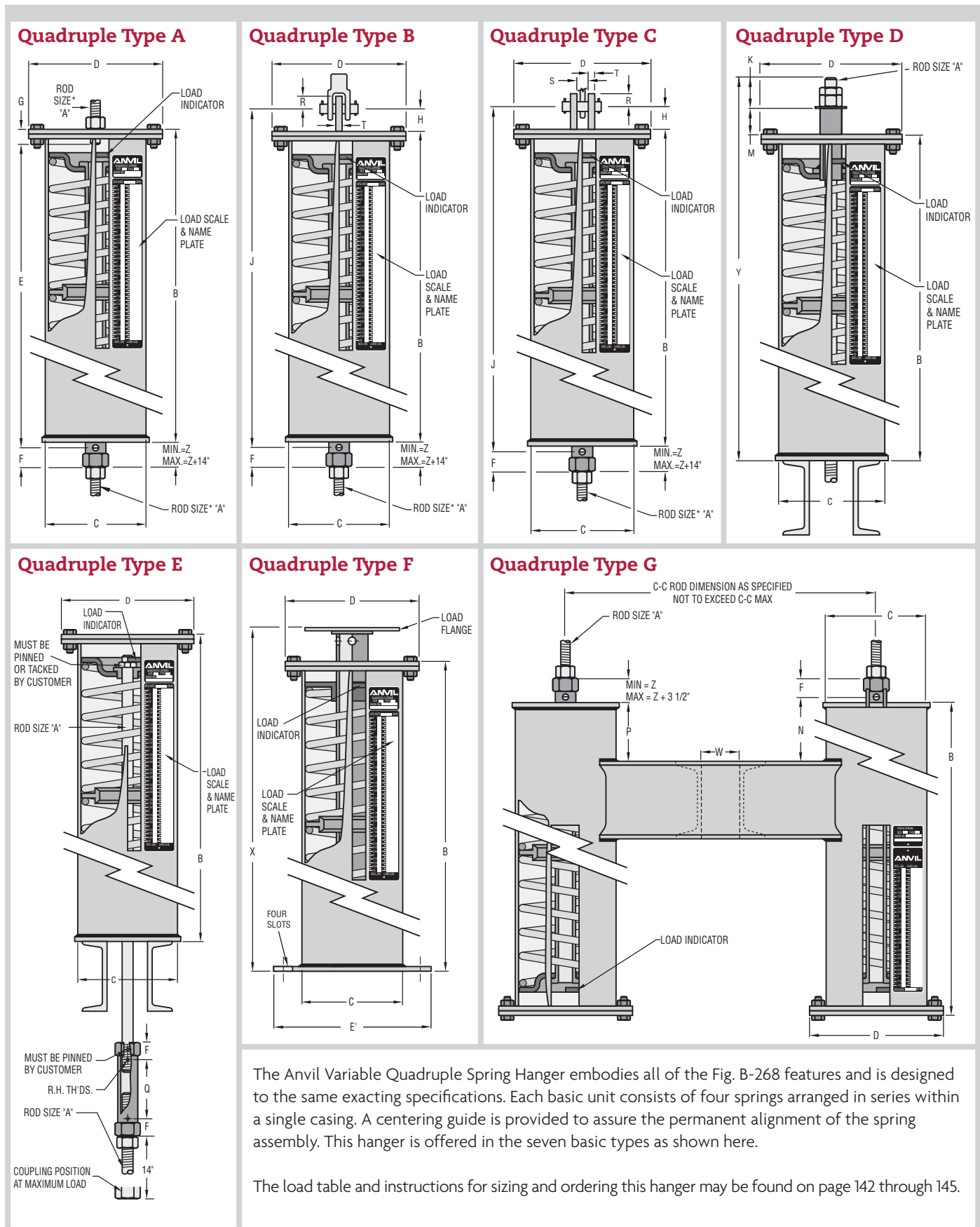

Quadruple Spring, Quadruple Spring-CR

QUADRUPLE SPRING: DIMENSIONS (IN)																			
Hanger Size	General Dimensions						Rod Take Out For Types					Type A	Type D		Type F		Type G		
	Rod Size A	R.H. Thread Length	Casing Length B	Casing Dia. C	Min Thread F	Z	A	B & C	D	E	G	Depth Thread G	K	M	Loaded Length Dim X		P		
							E	J	Y	Q	N				Min	Max			
0	1/2	16	25 1/8	4	1 5/16	1 5/16	25 1/8	26 5/8	37 1/8	15 1/8	1 1/2	7/16	1 1/4	7 3/4	26 15/16	28 15/16	1 1/2		
1			28 5/8				30 1/8	40 5/8	30 7/16						32 7/16				
2			31 1/8				33 1/8	43 3/8	33 3/16						35 7/16				
3	1/2	16	27 7/8	5 9/16	1 5/16	1 5/16	27 7/8	29 3/8	39 7/8	15 1/8	2	7/16	1 1/4	7 3/4	29 11/16	31 11/16	2		
4			30 3/8				31 7/8	42 3/8	32 3/16						34 3/16				
5			33 3/8				34 5/8	45 1/8	34 15/16						36 15/16				
6	5/8	16	32 15/16	6 5/8	1 5/16	1 5/16	32 15/16	34 7/16	45 1/8	15 1/8	2	5/8	1 1/2	7 9/16	34 7/8	36 7/8	2		
7			36 7/8				38 3/8	49 1/16	38 13/16						40 13/16				
8			38 11/16				40 3/16	50 7/8	40 5/8						42 5/8				
9	3/4	16	38 13/16	8 5/8	1 1/4	1 1/4	38 13/16	40 5/16	51 1/8	15 1/2	3	1	1 3/4	7 1/16	40 7/8	42 7/8	3		
10			43 3/4				45 1/4	56 1/16	45 13/16						47 13/16				
11		17	35				35	36 1/2	47 5/16				37 1/16	39 1/16					
12	1	17	37 1/2	8 5/8	1 1/4	1 1/4	37 1/2	39 1/2	50 5/16	15 1/2	3 7/8	1	2 1/4	7 1/16	39 9/16	41 9/16	4		
13			47 3/4				49 3/4	60 9/16	49 13/16						51 13/16				
14			1 1/4				48 3/8	1 3/8	48 3/8				51 1/4	61 15/16	50 7/16	52 7/16			
15	1 1/4	18	48 1/8	8 5/8	1 3/8	1 1/4	48 1/8	51	61 15/16	15 1/2	4	1 3/8	3	7 1/16	50 3/16	52 3/16	4		
16	1 1/2		57 7/8				1 15/16	1 15/16	57 7/8						60 7/8	71 1/16		15 9/16	3 1/2
17	1 3/4		19				66 1/8	66 1/8	69 1/8				80 3/16	15 9/16	4	4		68 3/16	70 3/16
18	2	19	64 1/8	12 3/4	2 3/4	2 3/4	64 1/8	68 1/8	78 11/16	14 7/8	4	2 1/4	4 9/16	7	66 5/16	68 5/16	4		
19	2 1/4		73 1/8				73 1/8	77 5/8	88 1/8	15 1/16					5	75 5/16		77 5/16	
20	2 1/2		20				86 1/8	86 1/8	90 5/8	101 11/16			15 15/16	5 9/16	88 5/16	90 5/16			
21	2 3/4	21	95 7/8	12 3/4	3 5/8	3 5/8	95 7/8	99 3/8	113 3/16	15	4	2 3/4	6 1/4	9 5/16	98	100	4		
22	3		120 1/8				124 1/8	138 7/16	15 1/2	3					6 5/8	122 1/4		124 1/4	

Attachment rods and nuts not furnished.
See page 150 for Type F roller and guided load column information.

See Fig. B-268 for dimensions not listed

CONSTANT SUPPORTS

Model R

Mathematically Perfect Pipe Support

The exclusive geometric design of Anvil Model R Constant Support Hanger assures perfectly constant support through the entire deflection of the pipe load. This counter-balancing of the load and spring moments about the main pivot is obtained by the use of carefully designed compression type load springs, lever, and spring tension rods.

As the lever moves from the high to the low position, the load spring is compressed and the resulting increasing force acting on the decreasing spring moment arm creates a turning moment about the main pivot which is exactly equal and opposite to the turning moment of the load and load moment arm.

As the lever moves from the low to the high position, the load spring is increasing in length and the resulting decreasing force acting on the increasing spring moment arm creates a turning moment about the main pivot which is exactly equal and opposite to the turning moment of the load and load moment arm.

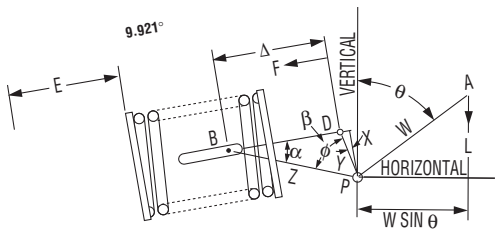
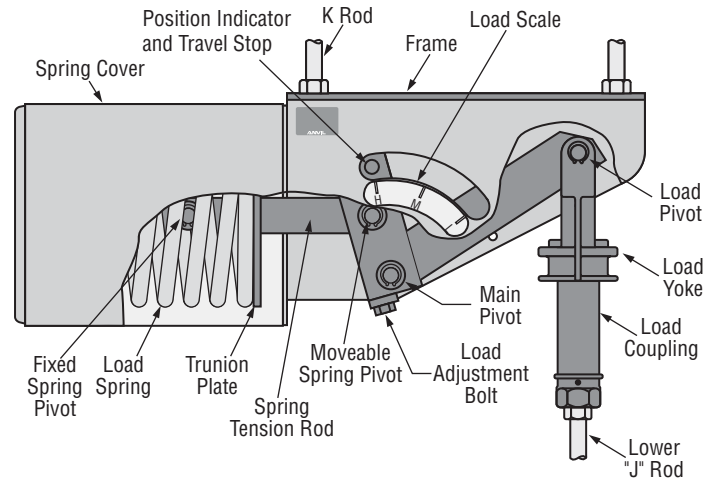

High Position

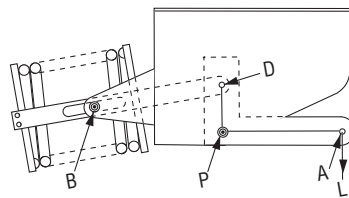

Middle Position

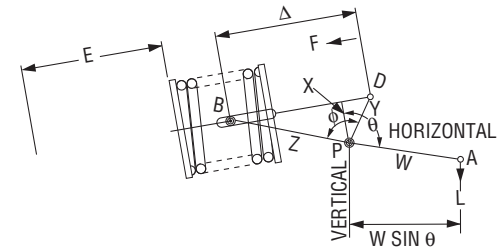

Low Position

$$(1) \frac{\sin \alpha}{Y} = \frac{\sin \phi}{\Delta} \quad \sin \beta = X$$

$$\frac{\sin \alpha}{Y} = \frac{\sin \beta}{Z} \quad \sin \alpha = \frac{X}{Z}$$

$$\sin \alpha = \frac{Y \sin \beta}{Z}$$

Substituting in (1), we have (2) $\frac{X}{YZ} = \frac{\sin \phi}{\Delta}$ and (3) $X = \frac{YZ \sin \phi}{\Delta}$

The load "L" is suspended from the lever at point "A" and at any point within the load travel range the moment of the load about the main lever-pivot "P" is equal to the load times its moment arm, thus:

$$(4) \text{Load moment} = L (W \sin \theta), \text{ where } (W \sin \theta) \text{ is the load moment arm}$$

The spring is attached at one of its ends to the fixed pivot "B". The spring's free end is attached by means of a rod to the lever-pivot "D". This spring arrangement provides a spring moment about the main lever-pivot "P" which opposes the load moment and is equal to the spring force "F" times its moment arm; thus:

$$(5) \text{Spring Moment} = F \left(\frac{YZ \sin \phi}{\Delta} \right),$$

where $\left(\frac{YZ \sin \phi}{\Delta} \right)$ is the spring moment arm

The spring force "F" is equal to the spring constant "K" times the spring deflection "E"; thus:

$$(6) F = KE; \text{ Therefore equation (5) may be written as:}$$

$$(7) \text{Spring Moment} = KE \left(\frac{YZ \sin \phi}{\Delta} \right)$$

To obtain perfect constant support the load moment must always equal the spring moment. Therefore:

$$(8) LW = \left(\frac{KEYZ \sin \phi}{\Delta} \right)$$

By proper design "phi" and "theta" are made equal. Therefore, equation (8) maybe written as:

$$(9) LW = \left(\frac{KEYZ}{\Delta} \right)$$

The spring and the rod are so arranged that the spring deflection "E" always equals the distance "Delta" between pivots "B" and "D". Therefore, equation (9) may be written as:

$$(10) LW = KYZ \text{ or, } (11) L = (KYZ)/W$$

Since equation (11) holds true for all positions of the load within its travel range and "K", "Y", "Z", and "W" remain constant it is therefore true that perfect constant support is obtained.

Model R Fig. 80-V, C-80-V Vertical Constant Support Model R Fig. 81-H, C-81-H Horizontal Constant Support

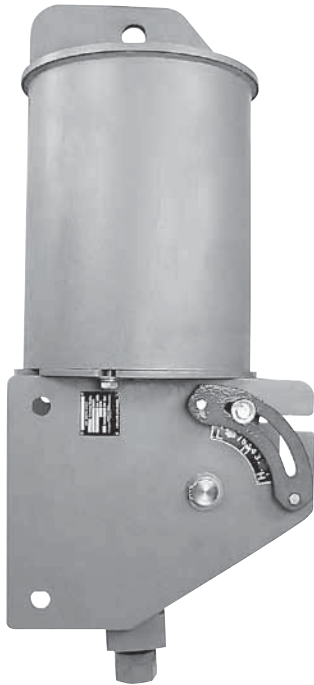

Model R Fig. 80-V, Vertical

Finish: Standard finish; painted with semi gloss primer. Corrosion resistant; galvanized with coated coil or painted with CZ11 and coated coil.

Recommended Service: When piping stress is critical and pipe is subject to vertical movement in excess of $1\frac{1}{2}$ " due to thermal expansion, and also at locations where it is necessary to avoid any transfer of stress from support or onto critical terminals or connecting equipment.

Approvals: WW-H-171E (Types 52, 58 and 59), ANSI/MSS SP-69 and MSS SP-58 (Types 54, 55 and 56).

Features:

- Because of exclusive geometric design, mathematically perfect constancy of support is maintained throughout the full range of load adjustment.
- Compactness – design provides smaller and more versatile units.
- Increased load and travel capacity.
- Each hanger is individually calibrated before shipment to support the exact load specified.
- All model R constant supports have a wide range of load adjustability. No less than 10% of this adjustability is provided either side of the calibrated load.
- White button marked "C" denotes cold setting of hanger; red button marked "H" denotes hot or operating setting.
- Field load adjustment is made by turning the single load adjustment bolt.
- Covered spring provides protection and good appearance.
- J-rod swings at least 4° from vertical.
- Non-resonant to all vertical vibrations.

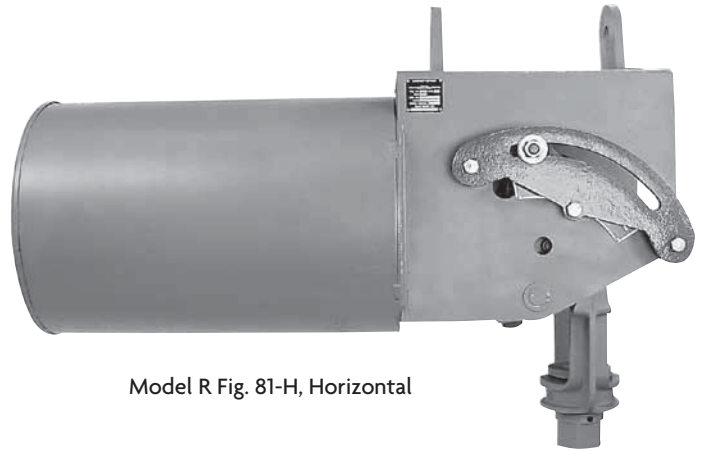

Model R Fig. 81-H, Horizontal

Size Range: Anvil Model R constant support hangers are made in two basic designs, 80- V (vertical design) and 81-H (horizontal design). Combined, the 80-V and 81-H constant supports are made in nine different frame sizes and 110 spring sizes to accommodate travels from $1\frac{1}{2}$ " to 20" and loads from 27 lbs to 87,500 lbs.

Single rod suspension: Available in Types A, B and C, Fig. 80-V (see page 178 through 170) and Fig. 81-H (see page 175 through 177).

How to select hanger sizes: Determine the total load to be supported by the hanger as well as the actual travel – that is, the actual vertical movement of the pipe at the point of hanger location. Refer to the Load-Travel table for constant support hangers (see page 164 through 167) and select a size hanger which will accommodate the known load and actual travel. It must be noted that the travel shown in the table is a total travel – that is, the maximum vertical movement which the hanger will accommodate. The total travel of the hanger should always be greater than the calculated travel of pipe line to allow for some discrepancy between calculated travel and actual travel.

It is suggested that the total travel for constant supports should be equal to "actual travel" plus 1" or 20% whichever is greater.

How to determine type: After the size of the constant support is determined, consideration of available room for suspending the pipe and hanger will indicate whether a vertical (80-V series, page 168 - 174) or horizontal (81-H series, page 175 - 181) hanger is desirable.

How to determine design: After the hanger size and design are determined, the type of constant support to be used depends upon the physical installation required by the suspension problem, i.e., whether the hanger is to be installed above, between or below steel members (see line cuts referring to Types A, B, C, etc.). It will be noted that the Type F is made in horizontal design only and the type G is made in the vertical design only. **Special constant support hangers can be fabricated for unusual conditions.**

J-rod and K-hole diameter: Tapping or drilling for standard rod size will be furnished as shown in the J-rod and K-hole selection charts unless otherwise specified. Upper attachments, turnbuckles and clamps should be tapped to agree with the rod as shown in the selection chart. Standard rod diameters are based on the load to be carried by the upper rod which includes the weight of the hanger assembly as well as the pipe line. Tapped connections for hanger rod sizes 3" and smaller are UNC-Thread Series, Class 2 fit. $3\frac{1}{4}$ " and large rod tappings are 8UN Series Threads.

Model R

(Continued)

Ordering: Specify:

- (1) Hanger size number
- (2) Figure number
- (3) Type
- (4) Name of hanger
- (5) Loads to be supported (pounds)
- (6) Total travel (inches)
- (7) Actual travel (inches)
- (8) Direction of movement "cold to hot"
- (9) Customer's hanger mark.
- (10) When ordering Type G, specify C-C rod dimension as well as load per spring and total load.
- (11) For Types A, B, C, Fig. 81-H when required specify "for single rod suspension."
- (12) Constant Support Hangers are also available corrosion-resistant as figures C-80-V and C-81-H.

Installation:

- (1) Securely attach the hanger to the building structure at a point where the load coupling is directly over the desired point of attachment to the pipe in the operating position.
- (2) Make certain that the moving parts of the hanger will be unobstructed.
- (3) Attach the lower J-rod between the pipe attachment and the load coupling. Make certain that the lower J-rod has enough thread engagement before taking up the load. A sight hole is provided for this.
- (4) Turn the load coupling, as you would a turnbuckle, until the travel indicator rotates to the desired cold setting (white button) marked "C" indicated on the position scale. If the constant support incorporates a travel stop see below.
- (5) After the line is in operation, check hanger for indicated hot setting. If necessary, make adjustment by turning the load coupling to bring the indicator to the hot position (red button) marked "H". No other adjustment is normally required since the load as calibrated at the factory is equal to the load specified to be supported.

Adjustment: When the hanger is installed, its supporting force should be in balance with the portion of the piping weight assigned to it. Each hanger is individually calibrated before shipment to support the exact load specified. All model "R" Constant Supports have a wide range of load adjustability. Special instructions for field recalibration of individual hangers may be obtained from Anvil representatives. No less than 10% adjustability is provided either side of the calibrated load for plus or minus field load adjustment. The percentage increase or decrease from the factory calibrated load should be carefully calculated. The calibrated load setting of each hanger is indicated by a die-stamp on the load adjustment scale. Load adjustments should be made from this reference point, with each division on the patented scale equal to 2% except sizes 84-110 where each division is valued at 1%. The load adjustment is made by turning the single load adjustment bolt. For example, a calibrated load of 3,000 pounds revised to 2,760 pounds is a decrease of 240 pounds. $240/3,000 = 8\%$. By turning the load adjusting bolt the arrow moves in the "Decrease" direction four divisions.

Note: Field Recalibration of load does not decrease total travel.

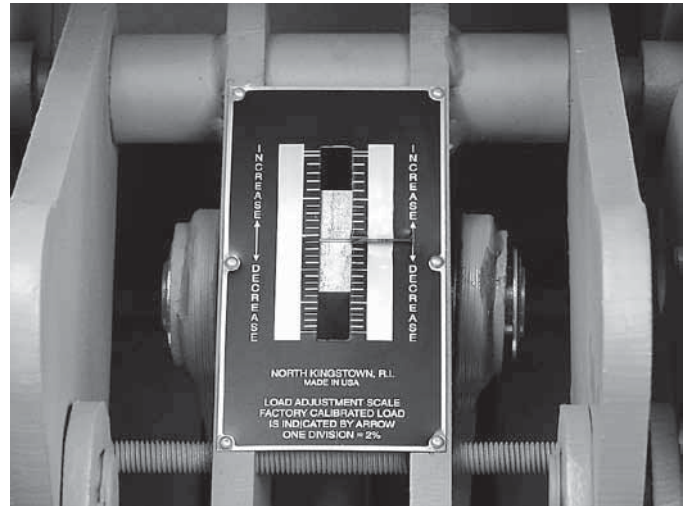

Load adjustment scale shown applies to size 1 through 83 only. The load adjustment scale for sizes 84 through 110 1 division equals 1%.

Travel stop: The functional design of the Constant Support Hanger permits the incorporation of a travel stop that will lock the hanger against upward or downward movement for temporary conditions of underload or overload, such as may exist during erection, hydrostatic test or chemical clean-out. Anvil Constant Supports are designed for hydrostatic test load of at least 2 times the normal operating load for the Constant Support. The travel stop for sizes 19 - 110 consists of two plates, with matched serrations, attached to the hanger frame with two or more cap screws and with a socketed piece which engages the position indicator. It is installed at the factory to hold the hanger in the "cold" position. A series of serrations can be engaged to lock the hanger at any position along the total travel range. The travel stop, which is furnished only when specified, is painted red. The stop must be removed before the piping system is put into operation, but not before the hanger is installed and fully loaded. The travel stop is released by removing the cap screws. A tag marked "Caution" and containing instructions for removal of the travel stop is attached to the hanger.

Note: See installation procedures PE-217-80 for a travel stop description on sizes 1-18.



Model R

(Continued)

Model R lifting lugs:

To help alleviate the problem of lifting large size Constant Supports into position for installation, this product is available with lifting lugs (if requested) on sizes ten and larger.

Lifting Lugs (Figure 81-H): Not available on Type F.

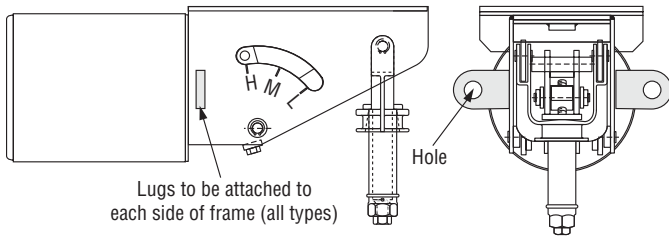
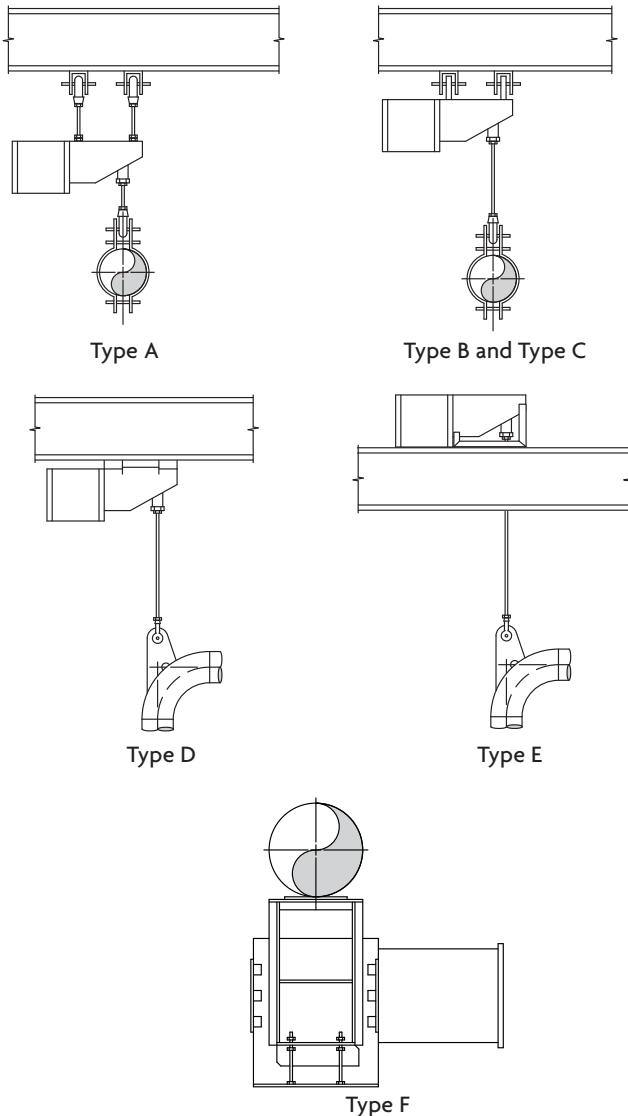

Fig. 81-H (Horizontal): Typical Applications



Lifting Lugs (Fig 80-V):

LUGS TO BE 90° FROM CHANNEL ON TYPE D

Types A, B, C, D, & E
sizes 10 thru 63

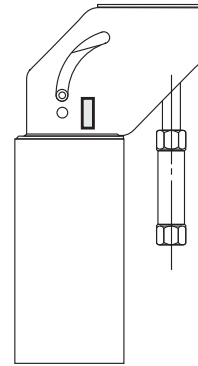
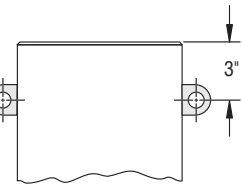

sizes 84 thru 110

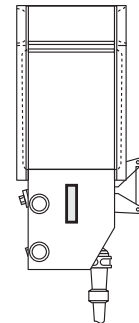

sizes 64 thru 83
Lugs to be attached to each side of frame and will need stabilizing rigging when being lifted

Fig. 80V (Vertical): Typical Applications

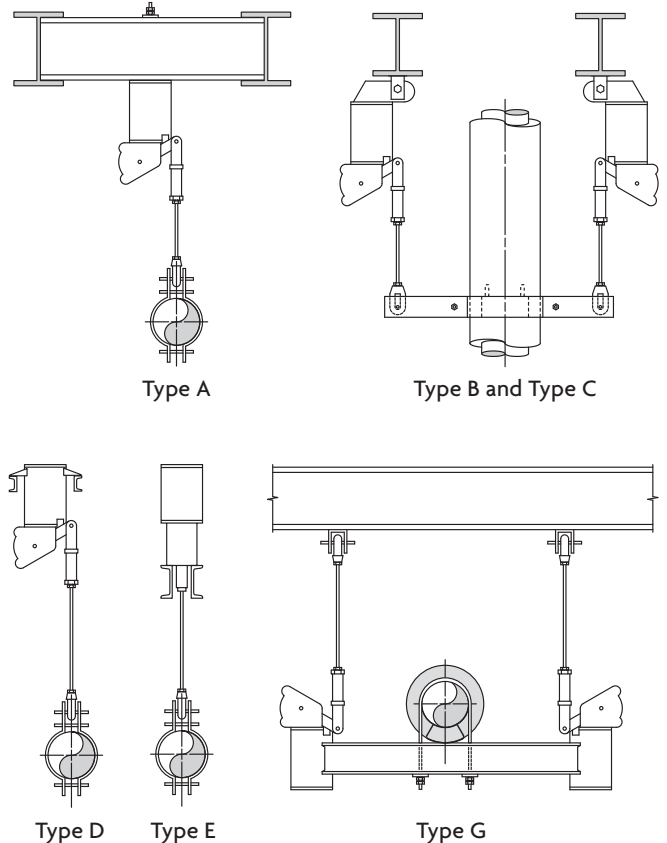

- Straps
- Pipe Supports
- Trapeze
- Pipe Shields & Saddles
- Pipe Roll
- Pipe Guides & Slides
- Spring Hangers
- Constant Supports
- Vibration Control & Sway Brace
- Sway Strut Assembly
- Snubbers
- Special Design Products
- Application Examples
- Master Format 3 Part Specs.
- Technical Data
- Index

CONSTANT SUPPORTS

Hanger Size No.	TOTAL TRAVEL* (IN); LOAD (LBS) SEE NOTES ON PAGE 167														
	1½	2	2½	3	3½	4	4½	5	5½	6	6½	7	7½	8	8½
1	144	108	86	72	62	54	48	43	39	36	33	31	29	27	
	173	130	104	87	74	65	58	52	47	43	40	37	35	33	
2	204	153	122	102	87	77	68	61	56	51	47	44	41	38	
3	233	175	140	117	100	88	78	70	64	58	54	50	47	44	
4	280	210	168	140	120	105	93	84	76	70	65	60	56	53	
5	327	245	196	163	140	123	109	98	89	82	75	70	65	61	
6	373	280	224	187	160	140	124	112	102	93	86	80	75	70	
7	451	338	270	225	193	169	150	135	123	113	104	97	90	85	
8	527	395	316	263	226	198	176	158	144	132	122	113	105	99	
9	600	450	360	300	257	225	200	180	164	150	138	129	120	113	
10	727	545	436	363	311	273	242	218	198	182	168	156	145	136	
11	851	638	510	425	365	319	284	255	232	213	196	182	170	160	
12	977	733	586	489	419	367	326	293	267	244	226	209	195	183	
13	1,177	883	706	589	505	442	392	353	321	294	272	252	235	221	
14	1,373	1,030	824	687	589	515	458	412	375	343	317	294	275	258	
15	1,573	1,180	944	787	674	590	524	472	429	393	363	337	315	295	
16	1,893	1,420	1,136	947	811	710	631	568	516	473	437	406	379	355	
17	2,217	1,663	1,330	1,109	950	832	739	665	605	554	512	475	443	416	
18	2,540	1,905	1,524	1,270	1,089	953	847	762	693	635	586	544	508	476	
19		2,025	1,620	1,350	1,157	1,013	900	810	736	675	623	579	540	506	448
															476
20		2,145	1,716	1,430	1,226	1,073	953	858	780	715	660	613	572	536	505
21		2,335	1,868	1,557	1,334	1,168	1,038	934	849	778	718	667	623	584	549
22		2,525	2,020	1,683	1,443	1,263	1,122	1,010	918	842	777	721	673	631	594
23		2,710	2,168	1,807	1,549	1,355	1,204	1,080	985	903	834	775	723	678	638
24		2,910	2,328	1,940	1,663	1,455	1,293	1,164	1,058	970	895	831	776	728	685
25		3,110	2,488	2,073	1,777	1,555	1,382	1,244	1,131	1,037	957	889	829	778	732
26		3,310	2,648	2,207	1,891	1,655	1,471	1,324	1,204	1,103	1,018	946	883	828	779
27		3,630	2,904	2,420	2,074	1,815	1,613	1,452	1,320	1,210	1,117	1,037	968	908	854
28		3,950	3,160	2,633	2,257	1,975	1,756	1,580	1,436	1,317	1,215	1,129	1,053	988	929
29		4,270	3,416	2,847	2,440	2,135	1,898	1,708	1,553	1,423	1,314	1,220	1,139	1,068	1,005
30		4,535	3,628	3,023	2,591	2,268	2,016	1,814	1,649	1,512	1,395	1,296	1,209	1,134	1,067
31		4,795	3,836	3,197	2,740	2,398	2,131	1,918	1,744	1,598	1,475	1,370	1,279	1,199	1,128
32		5,060	4,048	3,373	2,891	2,530	2,249	2,024	1,840	1,687	1,557	1,446	1,349	1,265	1,191
33		5,295	4,236	3,530	3,026	2,648	2,353	2,118	1,925	1,765	1,629	1,513	1,412	1,324	1,246
34		5,525	4,420	3,683	3,157	2,763	2,456	2,210	2,009	1,842	1,700	1,579	1,473	1,381	1,300
35			4,696	3,913	3,354	2,935	2,609	2,348	2,135	1,957	1,806	1,677	1,565	1,468	1,381
36			4,968	4,140	3,549	3,105	2,760	2,484	2,258	2,070	1,911	1,774	1,656	1,553	1,461
37			5,240	4,367	3,743	3,275	2,911	2,620	2,382	2,183	2,015	1,871	1,747	1,638	1,541
38			5,616	4,680	4,011	3,510	3,120	2,808	2,553	2,340	2,160	2,006	1,872	1,755	1,652
39			5,988	4,990	4,277	3,743	3,327	2,994	2,722	2,495	2,303	2,139	1,996	1,871	1,761
40			6,360	5,300	4,543	3,975	3,533	3,180	2,891	2,650	2,446	2,271	2,120	1,988	1,871
41			6,976	5,813	4,983	4,360	3,876	3,488	3,171	2,907	2,683	2,491	2,325	2,180	2,052
42			7,588	6,323	5,420	4,743	4,216	3,794	3,449	3,162	2,919	2,710	2,529	2,371	2,232
43			8,200	6,833	5,857	5,125	4,556	4,100	3,727	3,417	3,154	2,929	2,733	2,563	2,412
44			8,724	7,270	6,231	5,453	4,847	4,362	3,965	3,635	3,355	3,116	2,908	2,726	2,566
45			9,284	7,737	6,631	5,803	5,158	4,642	4,220	3,868	3,571	3,316	3,095	2,901	2,731
46			9,760	8,133	6,971	6,100	5,422	4,880	4,436	4,067	3,754	3,486	3,253	3,050	2,871
47			10,376	8,647	7,411	6,485	5,764	5,188	4,716	4,323	3,991	3,706	3,459	3,243	3,052
48			10,988	9,157	7,848	6,868	6,104	5,494	4,995	4,578	4,226	3,924	3,663	3,434	3,232
49			11,600	9,667	8,286	7,250	6,444	5,800	5,273	4,833	4,462	4,143	3,867	3,625	3,412
50				10,367	8,886	7,775	6,911	6,220	5,655	5,183	4,785	4,443	4,147	3,888	3,659
51				11,067	9,486	8,300	7,378	6,640	6,036	5,533	5,108	4,743	4,427	4,150	3,906
52				11,847	10,154	8,885	7,898	7,108	6,462	5,923	5,468	5,077	4,739	4,443	4,181
53				12,623	10,820	9,468	8,415	7,574	6,886	6,311	5,826	5,410	5,049	4,734	4,455
54				13,400	11,486	10,050	8,933	8,040	7,309	6,700	6,185	5,743	5,360	5,025	4,730
55				14,713	12,611	11,035	9,809	8,828	8,026	7,356	6,791	6,306	5,885	5,518	5,193
56				16,023	13,734	12,018	10,682	9,614	8,740	8,011	7,396	6,867	6,409	6,009	5,655
57				17,333	14,857	13,000	11,555	10,400	9,455	8,666	8,000	7,429	6,933	6,500	6,118
58				18,423	15,791	13,818	12,282	11,054	10,049	9,211	8,503	7,896	7,369	6,809	6,503
59				19,510	16,723	14,633	13,007	11,706	10,642	9,755	9,005	8,362	7,804	7,316	6,886
60				20,600	17,657	15,450	13,733	12,360	11,236	10,300	9,508	8,829	8,240	7,725	7,271
61				21,890	18,763	16,418	14,593	13,134	11,940	10,945	10,103	9,382	8,756	8,209	7,726
62				23,176	19,665	17,383	15,451	13,906	12,642	11,588	10,697	9,933	9,270	8,691	8,180
63				24,463	20,968	18,348	16,309	14,678	13,344	12,231	11,291	10,484	9,785	9,174	8,634
"B" (avg. in.)	1⅜	1⅞	2¼	2¾	3¼	3⅝	4⅞	4⅝	5⅞	5½	6	6½	6⅞	7⅞	7⅞

Table Continued on Facing Page

Shading in gray indicates this item is available upon request.

CONSTANT SUPPORTS

Table Continued on Facing Page

Hanger Size No.	TOTAL TRAVEL* (IN); LOAD (LBS) SEE NOTES ON PAGE 167															
	9	9½	10	10½	11	11½	12	12½	13	13½	14	14½	15	15½	16	
1																
2																
3																
4																
5																
6																
7																
8																
9																
10																
11																
12																
13																
14																
15																
16																
17																
18																
19	423	401	381													
	450	426	405													
20	477	452	429													
21	519	492	467													
22	561	532	505													
23	602	571	542													
24	647	613	582													
25	691	655	622													
26	736	697	662													
27	807	764	726													
28	878	832	790													
29	949	899	854													
30	1,008	955	907													
31	1,066	1,009	959													
32	1,124	1,065	1,012													
33	1,177	1,115	1,059													
34	1,228	1,163	1,105													
35	1,304	1,236	1,174	1,053	1,005	962	922	885	851	819	790					
				1,118	1,067	1,021	978	939	903	870	838					
36	1,380	1,307	1,242	1,183	1,129	1,080	1,035	994	955	920	887					
37	1,456	1,379	1,310	1,248	1,191	1,139	1,092	1,048	1,008	970	936					
38	1,560	1,478	1,404	1,337	1,276	1,221	1,170	1,123	1,080	1,040	1,003					
39	1,663	1,576	1,497	1,426	1,361	1,302	1,247	1,198	1,151	1,109	1,069					
40	1,767	1,674	1,590	1,514	1,445	1,383	1,325	1,272	1,223	1,178	1,136					
41	1,938	1,836	1,744	1,661	1,585	1,516	1,453	1,395	1,341	1,292	1,246					
42	2,108	1,997	1,897	1,807	1,724	1,649	1,581	1,518	1,459	1,405	1,355					
43	2,278	2,158	2,050	1,952	1,863	1,782	1,708	1,640	1,577	1,518	1,464					
44	2,423	2,296	2,181	2,077	1,983	1,896	1,817	1,745	1,678	1,615	1,558					
45	2,579	2,443	2,321	2,210	2,110	2,018	1,934	1,857	1,785	1,719	1,658					
46	2,711	2,568	2,440	2,324	2,218	2,122	2,033	1,952	1,877	1,807	1,743					
47	2,882	2,730	2,594	2,470	2,358	2,255	2,162	2,075	1,995	1,921	1,853					
48	3,052	2,891	2,747	2,616	2,497	2,389	2,289	2,198	2,113	2,035	1,962					
49	3,222	3,053	2,900	2,762	2,636	2,522	2,417	2,320	2,231	2,148	2,071					
50	3,456	3,274	3,110	2,962	2,827	2,704	2,592	2,488	2,392	2,304	2,221	2,001	1,934	1,871	1,813	
												2,145	2,073	2,006	1,944	
51	3,689	3,495	3,320	3,162	3,018	2,887	2,767	2,656	2,554	2,459	2,371	2,289	2,213	2,142	2,075	
52	3,949	3,741	3,554	3,384	3,231	3,090	2,962	2,843	2,734	2,632	2,538	2,451	2,369	2,293	2,221	
53	4,208	3,986	3,787	3,606	3,442	3,293	3,156	3,030	2,913	2,805	2,705	2,612	2,524	2,443	2,367	
54	4,467	4,231	4,020	3,828	3,654	3,495	3,350	3,216	3,092	2,978	2,871	2,772	2,680	2,593	2,513	
55	4,904	4,646	4,414	4,203	4,012	3,838	3,678	3,531	3,395	3,269	3,152	3,044	2,942	2,847	2,759	
56	5,341	5,060	4,807	4,518	4,370	4,180	4,006	3,846	3,698	3,561	3,433	3,315	3,204	3,101	3,004	
57	5,778	5,474	5,200	4,952	4,727	4,521	4,333	4,160	4,000	3,852	3,714	3,586	3,466	3,355	3,250	
58	6,141	5,818	5,527	5,263	5,024	4,806	4,606	4,422	4,251	4,094	3,947	3,811	3,684	3,565	3,454	
59	6,503	6,161	5,853	5,574	5,320	5,089	4,877	4,682	4,502	4,335	4,180	4,036	3,902	3,776	3,658	
60	6,867	6,505	6,180	5,885	5,618	5,374	5,150	4,944	4,754	4,578	4,414	4,262	4,120	3,987	3,863	
61	7,297	6,912	6,567	6,254	5,969	5,710	5,472	5,254	5,051	4,864	4,690	4,529	4,378	4,236	4,104	
62	7,725	7,319	6,953	6,621	6,320	6,046	5,794	5,562	5,348	5,150	4,965	4,795	4,635	4,485	4,346	
63	8,154	7,725	7,339	6,989	6,671	6,381	6,116	5,871	5,645	5,436	5,242	5,061	4,892	4,734	4,587	
"B" (avg. in.)	8¼	8¾	9¼	9⅝	10⅞	10⅝	11	11½	12	12⅜	12⅞	13⅜	13⅞	14¼	14¾	

Shading in gray indicates this item is available upon request.



CONSTANT SUPPORTS

Hanger Size No.	TOTAL TRAVEL* (IN); LOAD (LBS) SEE NOTES ON PAGE 167																
	4	4½	5	5½	6	6½	7	7½	8	8½	9	9½	10	10½	11	11½	12
64	19,225	17,089	15,380	13,982	12,816	11,831	10,986	10,253	9,613	9,047	8,544	8,094	7,690	7,323	6,990	6,686	6,408
65	20,100	17,866	16,080	14,618	13,400	12,370	11,486	10,720	10,050	9,459	8,933	8,463	8,040	7,657	7,308	6,991	6,700
66	22,068	19,615	17,654	16,049	14,711	13,580	12,610	11,769	11,034	10,385	9,808	9,291	8,827	8,406	8,024	7,675	7,356
67	24,033	21,362	19,226	17,478	16,021	14,790	13,733	12,817	12,016	11,310	10,681	10,119	9,613	9,154	8,738	8,359	8,011
68	26,000	23,111	20,800	18,909	17,333	16,000	14,857	13,866	13,000	12,236	11,555	10,947	10,400	9,904	9,454	9,043	8,666
69	27,635	24,564	22,108	20,098	18,423	17,007	15,792	14,738	13,818	13,005	12,282	11,635	11,054	10,527	10,048	9,611	9,211
70	29,268	26,015	23,414	21,286	19,511	18,011	16,725	15,609	14,632	13,773	13,008	12,323	11,707	11,149	10,642	10,179	9,755
71	30,900	27,466	24,720	22,473	20,599	19,016	17,657	16,480	15,450	14,542	13,733	13,010	12,360	11,770	11,235	10,747	10,300
72	32,835	29,186	26,268	23,880	21,889	20,207	18,763	17,512	16,418	15,452	14,593	13,825	13,134	12,508	11,939	11,420	10,945
73	34,768	30,904	27,814	25,286	23,177	21,396	19,868	18,542	17,384	16,362	15,452	14,639	13,907	13,244	12,641	12,092	11,589
74	36,700	32,622	29,360	26,691	24,466	22,585	20,972	19,573	18,350	17,271	16,311	15,452	14,680	13,980	13,344	12,764	12,233
75	38,800	34,489	31,040	28,218	25,866	23,878	22,172	20,693	19,400	18,259	17,244	16,336	15,520	14,780	14,108	13,495	12,933
76	40,900	36,355	32,720	29,746	27,266	25,170	23,372	21,813	20,450	19,248	18,178	17,221	16,360	15,580	14,871	14,225	13,633
77	43,000	38,222	34,400	31,273	28,666	26,462	24,572	22,933	21,500	20,236	19,111	18,105	17,200	16,380	15,635	14,955	14,333
78	45,335	40,297	36,268	32,971	30,222	27,899	25,906	24,178	22,668	21,335	20,149	19,088	18,134	17,269	16,484	15,768	15,111
79	47,668	42,371	38,134	34,668	31,779	29,335	27,239	25,422	23,834	22,432	21,185	20,070	19,067	18,158	17,332	16,579	15,889
80	50,000	44,444	40,000	36,364	33,332	30,770	28,572	26,666	25,000	23,530	22,222	21,052	20,000	19,046	18,180	17,390	16,666
81	52,500	46,666	42,000	38,182	35,000	32,309	30,000	27,999	26,250	24,707	23,333	22,105	21,000	19,998	19,089	18,260	17,500
82	55,000	48,888	44,000	40,000	36,665	33,847	31,429	29,333	27,500	25,883	24,444	23,157	22,000	20,951	20,000	19,129	18,333
83	57,500	51,111	46,000	41,819	38,332	35,386	32,858	30,666	28,750	27,060	25,555	24,210	23,000	21,903	20,907	20,000	19,166
84			49,200	44,728	40,998	37,847	35,144	32,799	30,750	28,942	27,333	25,894	24,600	23,427	22,361	21,390	20,500
85			52,400	47,637	43,665	40,309	37,429	34,932	32,750	30,824	29,111	27,578	26,200	24,950	23,816	22,781	21,832
86			55,400	50,364	46,165	42,616	39,572	36,932	34,625	32,589	30,777	29,157	27,700	26,379	25,179	24,085	23,082
87			58,400	53,091	48,665	44,924	41,715	38,932	36,500	34,354	32,444	30,736	29,200	27,807	26,543	25,389	24,332
88			61,400	55,819	51,165	47,232	43,858	40,932	38,375	36,119	34,111	32,315	30,700	29,236	27,906	26,694	25,582
89			66,000	60,000	54,998	50,771	47,144	43,999	41,250	38,825	36,666	34,736	33,000	31,426	29,997	28,694	27,500
90					61,331	56,617	52,572	49,065	46,000	43,295	40,888	38,736	36,800	35,045	33,451	31,998	30,665
91					67,164	62,002	57,573	53,732	50,375	47,413	44,777	42,420	40,300	38,378	36,633	35,041	33,582
92					73,500	67,848	63,001	58,799	55,125	51,884	49,000	46,420	44,100	41,996	40,087	38,345	36,749
93					80,830	74,617	69,287	64,665	60,625	57,060	53,888	51,051	48,500	46,187	44,087	42,171	40,415
94					87,500	81,540	75,716	70,665	66,250	62,355	58,888	55,788	53,000	50,472	48,177	46,084	44,165
95							78,930	73,665	69,063	65,002	61,388	58,156	55,250	52,615	50,222	48,040	46,040
96							82,145	76,665	71,875	67,649	63,888	60,525	57,500	54,757	52,268	50,000	47,915
97							85,360	79,665	74,688	70,296	66,388	62,893	59,750	56,900	54,313	51,953	49,790
98							87,500	82,665	77,500	72,943	68,888	65,261	62,000	59,043	56,358	53,909	51,665
99								85,998	80,625	75,884	71,666	67,893	64,500	61,423	58,631	56,083	53,748
100								87,500	83,750	78,826	74,444	70,524	67,000	63,804	60,903	58,257	55,831
101									86,875	81,767	77,221	73,156	69,500	66,185	63,176	60,430	57,914
102									87,500	84,708	80,000	75,787	72,000	68,566	65,448	62,604	60,000
103										87,500	83,610	79,210	75,250	71,661	68,402	65,430	62,706
104											87,221	82,629	78,500	74,756	71,357	68,256	65,414
105											87,500	86,050	81,750	77,851	74,311	71,082	68,122
106												87,500	85,000	80,946	77,265	73,908	70,831
107													87,500	84,469	80,628	77,125	73,914
108														87,500	83,992	80,342	77,000
109															87,446	83,646	80,163
110															87,500	86,950	83,330
"B" dim Sizes 64 to 83	3¾	4⅛	4⅝	5⅛	5½	6	6½	6⅞	7⅜	7⅞	8¼	8¾	9¼	9⅝	10⅞	10⅞	11
"B" dim Sizes 84 to 110			4⅜	4⅞	5	5⅜	5⅞	6¼	6⅝	7⅞	7½	7⅞	8⅞	8¾	9⅞	9⅞	10

Table Continued on Facing Page

Shading in gray indicates this item is available upon request.

CONSTANT SUPPORTS

Table Continued on Facing Page

Hanger Size No.	TOTAL TRAVEL* (IN); LOAD (LBS)															
	12½	13	13½	14	14½	15	15½	16	16½	17	17½	18	18½	19	19½	20
64	6,152	5,915	5,696	5,492	5,303	5,126	4,961	4,806								
65	6,432	6,184	5,955	5,742	5,544	5,359	5,187	5,025								
66	7,062	6,790	6,538	6,304	6,087	5,884	5,694	5,517								
67	7,690	7,394	7,120	6,966	6,629	6,408	6,201	6,008								
68	8,320	8,000	7,703	7,428	7,172	6,933	6,709	6,500								
69	8,843	8,503	8,188	7,895	7,623	7,369	7,131	6,909								
70	9,366	9,005	8,671	8,361	8,073	7,804	7,552	7,317								
71	9,888	9,507	9,155	8,828	8,523	8,239	7,973	7,725								
72	10,507	10,103	9,728	9,380	9,057	8,755	8,473	8,209								
73	11,126	10,697	10,301	9,932	9,590	9,270	8,971	8,692								
74	11,744	11,292	10,873	10,484	10,123	9,786	9,470	9,175								
75	12,416	11,938	11,496	11,084	10,703	10,346	10,012	9,700								
76	13,088	12,584	12,118	11,684	11,282	10,906	10,554	10,225								
77	13,760	13,230	12,740	12,284	11,861	11,466	11,096	10,750								
78	14,507	13,949	13,432	12,951	12,505	12,088	11,698	11,334								
79	15,254	14,666	14,123	13,618	13,149	12,710	12,300	11,917								
80	16,000	15,384	14,814	14,284	13,792	13,332	12,902	12,500								
81	16,800	16,153	15,555	14,998	14,482	14,000	13,547	13,125								
82	17,600	16,922	16,295	15,712	15,171	14,665	14,192	13,750								
83	18,400	17,692	17,036	16,427	15,861	15,332	14,837	14,375								
84	19,680	18,922	18,221	17,569	16,964	16,398	15,869	15,375								
85	20,960	20,153	19,406	18,712	18,068	17,465	16,902	16,375								
86	22,160	21,307	20,517	19,783	19,102	18,465	17,869	17,313								
87	23,360	22,461	21,628	20,855	20,136	19,465	18,837	18,250								
88	24,560	23,614	22,739	21,926	21,171	20,465	19,805	19,188								
89	26,400	25,384	24,443	23,569	22,757	21,998	21,288	20,626								
90	29,440	28,307	27,258	26,283	25,377	24,531	23,740	23,000								
91	32,240	31,000	29,850	28,782	27,791	26,864	25,998	25,188								
92	35,280	33,922	32,665	31,496	30,411	29,397	28,449	27,563								
93	38,800	37,306	35,924	34,639	33,446	32,330	31,287	30,313								
94	42,400	40,768	39,257	37,583	36,549	35,330	34,190	33,125								
95	44,200	42,498	40,924	39,460	38,100	36,830	35,642	34,531	32,119	31,175	30,285	29,442	28,647	27,894	27,179	26,500
96	46,000	44,230	42,590	41,067	39,652	38,330	37,093	35,938	34,845	33,822	32,856	31,941	31,080	30,262	29,486	28,750
97	47,800	45,960	44,257	42,673	41,204	39,829	39,545	37,344	36,209	35,145	34,141	33,191	32,295	31,446	30,640	29,875
98	49,600	47,690	45,923	44,280	42,755	41,329	40,000	38,750	37,572	36,468	35,427	34,441	33,511	32,631	31,794	31,000
99	51,600	49,613	47,775	46,066	44,479	42,996	41,609	40,313	39,087	37,939	36,855	35,830	34,862	33,946	33,076	32,250
100	53,600	51,536	49,627	47,851	46,203	44,662	43,221	41,875	40,602	39,409	38,284	37,219	36,214	35,262	34,358	33,500
101	55,600	53,459	51,479	49,637	47,927	46,329	44,834	43,438	42,117	40,880	39,712	38,607	37,565	36,578	35,640	34,750
102	57,600	56,382	53,330	51,422	49,651	47,995	46,447	45,000	43,632	42,350	41,141	39,996	38,916	37,894	36,922	36,000
103	60,200	57,882	55,738	53,744	51,892	50,162	48,544	47,031	45,602	44,262	42,998	41,801	40,673	39,604	38,588	37,625
104	62,800	60,382	58,145	56,065	54,134	52,328	50,640	49,063	47,571	46,174	44,855	43,607	42,429	41,315	40,255	39,250
105	65,400	62,882	60,552	58,386	56,375	54,495	52,737	51,094	49,541	48,085	46,712	45,412	44,186	43,025	41,921	40,875
106	68,000	65,382	62,960	60,707	58,616	56,661	54,834	53,125	51,510	50,000	48,569	47,218	45,943	44,736	43,588	42,500
107	70,960	68,228	65,700	63,350	61,168	59,127	57,220	55,438	53,752	52,173	50,683	49,273	47,942	46,683	45,485	44,350
108	73,920	71,074	68,441	65,992	63,719	61,594	59,607	57,750	55,994	54,350	52,797	51,328	49,942	48,630	47,383	46,200
109	76,960	74,000	71,255	68,706	66,340	64,127	62,059	60,125	58,297	56,585	54,969	53,439	52,000	50,630	49,331	48,100
110	80,000	76,920	74,070	71,420	68,960	66,660	64,510	62,500	60,600	58,820	57,140	55,550	54,050	52,630	51,280	50,000
"B" dim Sizes 64 to 83	11½	12	12¾	12¾	13¾	13¾	14¼	14¾	-	-	-	-	-	-	-	-
"B" dim Sizes 84 to 110	10¾	10¾	11¾	11¾	12½	12½	12¾	13½	13½	14½	14½	15½	15½	16½	16½	16½

Shading in gray indicates this item is available upon request.

- * Note: Total travel equals actual travel plus 1" or 20% (whichever is greater), rounded up to nearest ½" as applicable.
- Constant supports are readily available for travel and load not listed in this table. Dimensions and lug locations may vary from those shown on the following pages.
- For Type F Upthrust see page 180 for standard travel and sizes.
- Fig. 80-V are not available for sizes 1 thru 9.



CONSTANT SUPPORTS

Fig. 80-V Type A

Model R

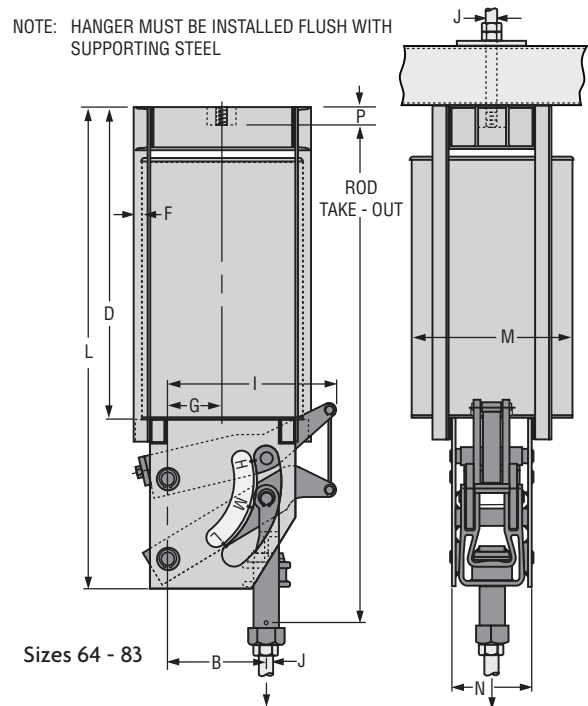
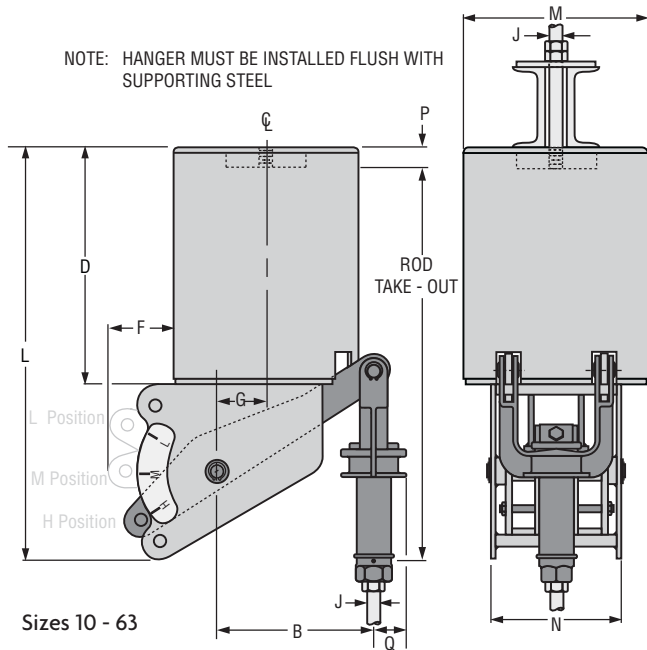

Type A of the figure 80-V vertical design model R Constant Support Hanger is designed for attachment to its supporting member by screwing a rod into a tapped hole in the top cap of hanger a distance equal to the "P" dimension plus $\frac{3}{8}$ ". Sight holes are provided near the top of the casing to allow visible inspection for correct thread engagement of upper hanger rod.

Notes: See load travel tables, page 164 through 167 for "B" dimension. For weights see page 182. Location of travel indicator and contour of side plate may vary from that shown.

FIG. 80-V, TYPE A: DIMENSIONS (IN)

Hanger Sizes	L	D	F	G	I	Dia. M	N	P	Q	Total Travel TT	Factors	J-rod		
												Min Thd Length	Rod Dia. Min Max	
1 - 9	Available in Fig. 81-H only													
10 - 18	18 $\frac{7}{8}$	8 $\frac{7}{8}$	2	1 $\frac{1}{2}$	•	8 $\frac{5}{8}$	6 $\frac{7}{16}$	$\frac{7}{8}$	1 $\frac{3}{8}$	5 or less 5 $\frac{1}{2}$ or more	16 $\frac{15}{16}$ 19 $\frac{1}{4}$	1 $\frac{3}{4}$ + TT	$\frac{1}{2}$	$\frac{3}{4}$
19 - 34	28 $\frac{1}{2}$	16	2 $\frac{1}{8}$	2 $\frac{5}{8}$	•	12 $\frac{3}{4}$	8 $\frac{9}{16}$	1 $\frac{1}{8}$	1 $\frac{5}{8}$	5 or less 5 $\frac{1}{2}$ or more	27 $\frac{15}{16}$ 30 $\frac{1}{16}$	2 $\frac{3}{8}$ + TT	$\frac{1}{2}$	1 $\frac{1}{4}$
35 - 49	32 $\frac{3}{4}$	18 $\frac{1}{4}$	4 $\frac{3}{4}$	3 $\frac{3}{4}$	•	14	9 $\frac{13}{16}$	1 $\frac{1}{2}$	2 $\frac{1}{2}$	6 or less 6 $\frac{1}{2}$ or more	32 $\frac{3}{8}$ 37	3 $\frac{1}{4}$ + TT	$\frac{1}{2}$	1 $\frac{3}{4}$
50 - 63	46 $\frac{7}{8}$	28 $\frac{3}{8}$	8 $\frac{5}{16}$	5 $\frac{7}{8}$	•	18	11 $\frac{1}{4}$	2	3	11 or less 11 $\frac{1}{2}$ or more	46 $\frac{1}{2}$ 51 $\frac{3}{4}$	4 $\frac{1}{4}$ + TT	$\frac{3}{4}$	2 $\frac{1}{4}$
64 - 74	67 $\frac{1}{2}$	44 $\frac{1}{4}$	1 $\frac{3}{16}$	7 $\frac{1}{2}$	25 $\frac{3}{8}$	22 $\frac{3}{16}$	11	2 $\frac{1}{2}$	-	10 $\frac{1}{2}$ or less 11 or more	77 $\frac{3}{8}$ 77 $\frac{3}{4}$	5 $\frac{3}{4}$ + TT	1 $\frac{1}{4}$	2 $\frac{3}{4}$
75 - 83	69 $\frac{1}{2}$	46 $\frac{1}{4}$	1 $\frac{1}{2}$	7 $\frac{1}{2}$	25 $\frac{3}{8}$	27 $\frac{3}{16}$	11	3	-	10 $\frac{1}{2}$ or less 11 or more	78 $\frac{3}{16}$ 78 $\frac{5}{16}$	5 $\frac{3}{4}$ + TT	1 $\frac{1}{2}$	3 $\frac{1}{4}$
84-110	See page 174													

Rod take-out = (factor) - (TT / 2), for lever in high position.

• "I" dimension for sizes 10 through 63 equals "B" + "Q" Note: See the size selection chart (page 164 through 167) for the "B" dimension.

J-ROD SELECTION CHART

Load (lbs)	0 800	801 1,500	1,501 2,540	2,541 4,000	4,001 6,100	6,101 9,400	9,401 13,400	13,401 18,300	18,301 24,700	24,701 31,000	31,001 39,000	39,001 48,000	48,001 58,000
J Rod Size	$\frac{1}{2}$	$\frac{5}{8}$	$\frac{3}{4}$	1	1 $\frac{1}{4}$	1 $\frac{1}{2}$	1 $\frac{3}{4}$	2	2 $\frac{1}{4}$	2 $\frac{1}{2}$	2 $\frac{3}{4}$	3	3 $\frac{1}{4}$ *

* 3 $\frac{1}{4}$ is furnished with 4 UNC series thread.

Fig. 80-V Type B

Model R

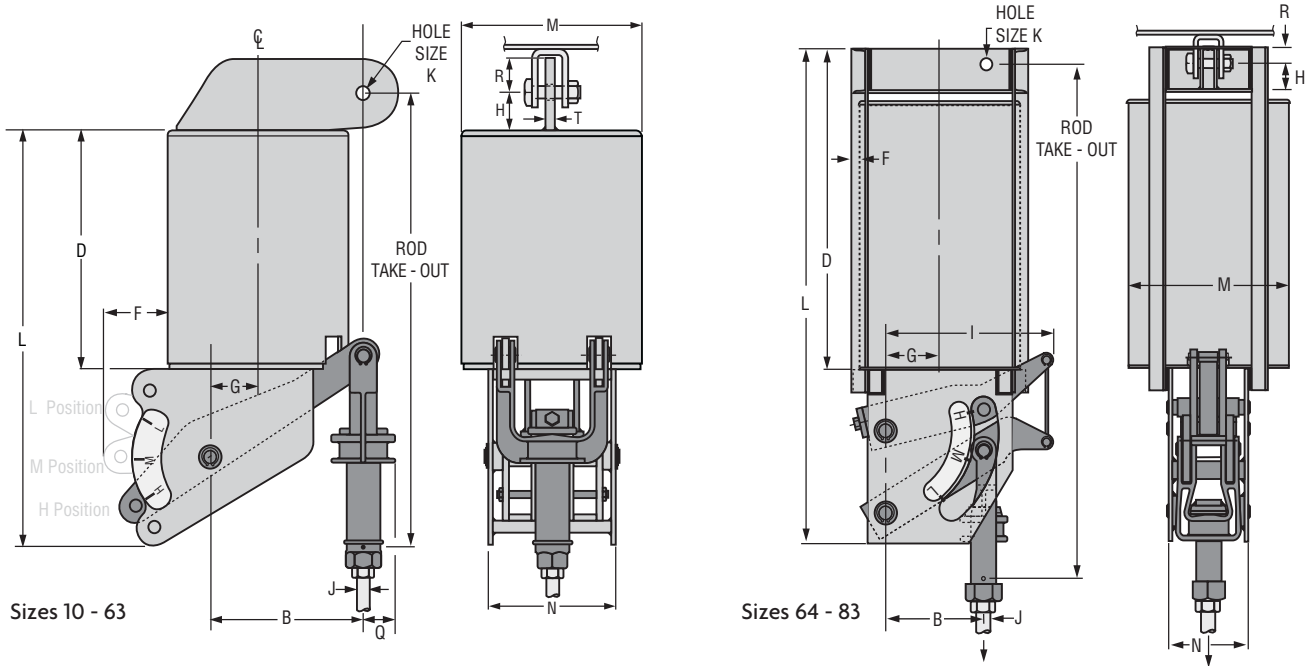

Type B is furnished with a single lug for attachment to the building structure. The lug permits use of a figure 66* welded beam attachment, a figure 299 clevis or a pair of angles for attachment where headroom is limited.

Notes: See load travel tables, page 164 through 167 for "B" dimension. For weights see page 182. Location of travel indicator and contour of side plate may vary from that shown.

FIG. 80-V, TYPE B: DIMENSIONS (IN)

Hanger Size	L	D	F	G	H	I	Dia. M	N	Q	R	T	Total Travel TT	Factors	J-rod		
														Min Thd Length	Rod Dia. Min	Max
1-9	Available in Fig. 81-H only															
10-18	18 ⁷ / ₈	8 ⁷ / ₈	2	1 ¹ / ₂	1 ¹ / ₂	•	8 ⁵ / ₈	6 ⁷ / ₁₆	1 ³ / ₈	1 ¹ / ₂	3 ⁸ / ₁₆	5 or less 5 ¹ / ₂ or more	19 ⁵ / ₁₆ 21 ⁵ / ₈	1 ³ / ₄ + TT	1 ¹ / ₂	3 ⁴ / ₈
19-34	28 ¹ / ₂	16	2 ¹ / ₈	2 ⁵ / ₈	2	•	12 ³ / ₄	8 ⁹ / ₁₆	1 ⁵ / ₈	1 ¹ / ₂	5 ⁸ / ₁₆	5 or less 5 ¹ / ₂ or more	31 ¹ / ₁₆ 33 ³ / ₁₆	2 ⁵ / ₈ + TT	1 ¹ / ₂	1 ¹ / ₄
35-49	32 ³ / ₄	18 ¹ / ₄	4 ³ / ₄	3 ³ / ₄	3	•	14	9 ¹³ / ₁₆	2 ¹ / ₂	1 ¹ / ₄ K-hole & smaller, 1 ¹ / ₂ 1 ³ / ₈ K-hole and larger, 2	3 ⁴ / ₁₆	6 or less 6 ¹ / ₂ or more	36 ⁷ / ₈ 41 ¹ / ₂	3 ³ / ₄ + TT	1 ¹ / ₂	1 ¹ / ₄
50-63	46 ⁷ / ₈	28 ³ / ₈	8 ⁵ / ₁₆	5 ⁵ / ₈	4	•	18	11 ¹ / ₄	3	1 ¹⁵ / ₁₆ K-hole, 1 ¹ / ₂ 1 ¹ / ₈ thru 1 ¹ / ₂ K-hole, 2 1 ³ / ₄ K-hole and larger, 3	1	11 or less 11 ¹ / ₂ or more	52 ¹ / ₂ 57 ³ / ₄	4 ¹ / ₄ + TT	3 ⁴ / ₈	2 ¹ / ₄
64-74	68	37 ¹ / ₄	1 ³ / ₁₆	7 ¹ / ₂	4 ¹ / ₂	25 ³ / ₈	22 ³ / ₁₆	11	3 ³ / ₄	1 ¹ / ₂ K-hole, 2 1 ³ / ₄ K-hole and larger, 3	2	10 ¹ / ₂ or less 11 or more	77 ¹ / ₄ 77 ³ / ₈	5 ³ / ₄ + TT	1 ¹ / ₄	2 ³ / ₄
75-83	69 ¹ / ₂	38	1 ¹ / ₂	7 ¹ / ₂	3 ⁵ / ₈	25 ³ / ₈	27 ³ / ₁₆	11		3 ³ / ₄	2 ¹ / ₂	10 ¹ / ₂ or less 11 or more	77 ¹⁵ / ₁₆ 78 ¹ / ₁₆	5 ³ / ₄ + TT	1 ¹ / ₂	3 ³ / ₄
84-110	See page 174															

Rod take-out = (factor) - (TT / 2), for lever in high position. • "I" dimension for sizes 10 through 63 equals "B" + "Q"

* For constant support sizes 50-63 and 64-74 where 1¹/₄" rod is required, check the "R" dimensions versus the Fig. 66 welded beam attachment dimensions for compatibility.

Note: See the size selection chart (page 164 through 167) for the "B" dimension. K hole center line location is determined by the formula of "B - G = K Center Line".

J-ROD SELECTION CHART

Load (lbs)	0 800	801 1,500	1,501 2,540	2,541 4,000	4,001 6,100	6,101 9,400	9,401 13,400	13,401 18,300	18,301 24,700	24,701 31,000	31,001 39,000	39,001 48,000	48,001 58,000
J-Rod Size	1/2	5/8	3/4	1	1 1/4	1 1/2	1 3/4	2	2 1/4	2 1/2	2 3/4	3	3 1/4*
K-Hole	1 1/16	1 3/16	1 5/16	1 1/4	1 1/2	1 3/4	2	2 3/8	2 5/8	2 7/8	3 1/8	3 3/8	3 5/8

* 3¹/₄" is furnished with 4 UNC series thread.



Straps
Pipe Supports
Trapeze
Pipe Shields & Saddles
Pipe Roll
Pipe Guides & Slides
Spring Hangers
Constant Supports
Vibration Control & Sway Brace
Sway Strut Assembly
Snubbers
Special Design Products
Application Examples
Master Format 3 Part Specs.
Technical Data
Index

CONSTANT SUPPORTS

Fig. 80-V Type C

Model R

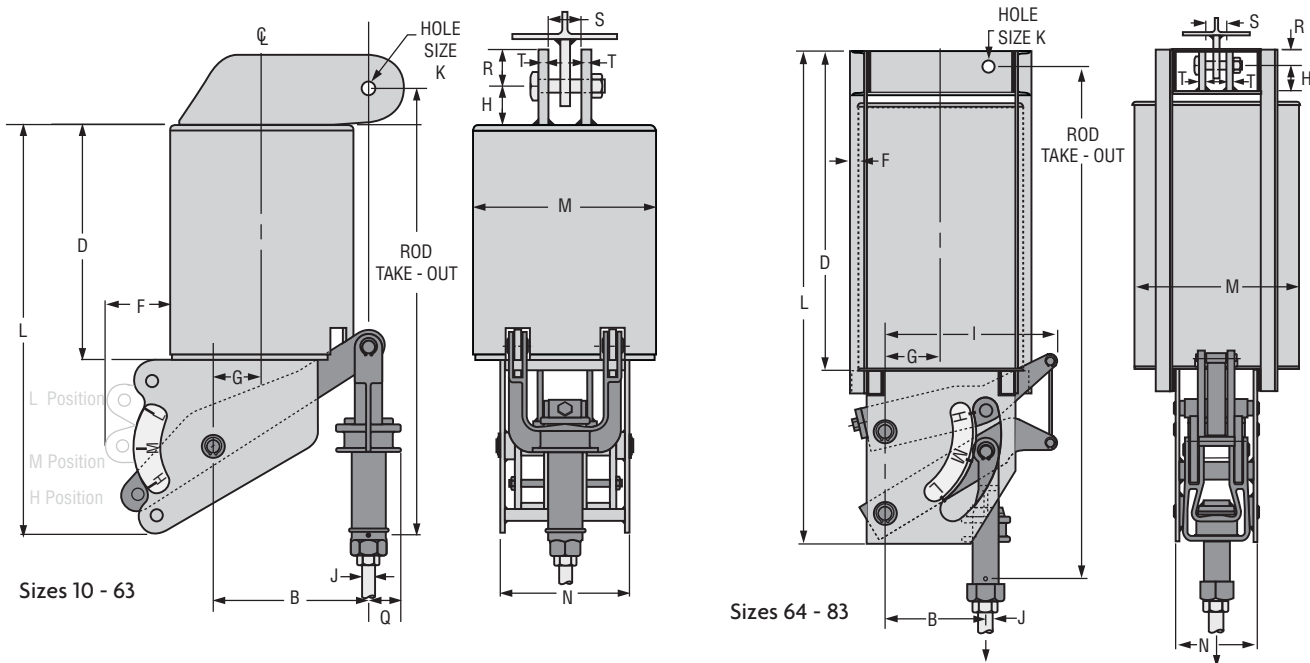

Type C is furnished with a pair of lugs for attachment to the building structure. These lugs permit the use of an eye rod or a single plate for attachment where headroom is limited.

Notes: See load travel tables, page 164 through 167 for "B" dimension. For weights see page 182. Location of travel indicator and contour of side plate may vary from that shown.

FIG. 80-V, TYPE C: DIMENSIONS (IN)

Hanger Size	L	D	F	G	H	I	Dia. M	N	Q	R	T	Total Travel TT	Factors	J-rod		
														Min	Thd Length	Rod Dia. Max
1-9	Available in Fig. 81-H only															
10-18	18 ⁷ / ₈	8 ⁷ / ₈	2	1 ¹ / ₂	1 ¹ / ₂	•	8 ⁵ / ₈	6 ⁷ / ₁₆	1 ³ / ₈	1 ¹ / ₂	3 ³ / ₈	5 or less 5 ¹ / ₂ or more	19 ⁵ / ₁₆ 21 ⁵ / ₈	1 ³ / ₄ + TT	1 ¹ / ₂	3 ³ / ₄
19-34	28 ¹ / ₂	16	2 ¹ / ₈	2 ⁵ / ₈	2	•	12 ³ / ₄	8 ⁹ / ₁₆	1 ⁵ / ₈	1 ¹ / ₂	5 ¹ / ₈	5 or less 5 ¹ / ₂ or more	31 ¹ / ₁₆ 33 ³ / ₁₆	2 ³ / ₈ + TT	1 ¹ / ₂	1 ¹ / ₄
35-49	32 ³ / ₄	18 ¹ / ₄	4 ³ / ₄	3 ³ / ₄	3	•	14	9 ¹³ / ₁₆	2 ¹ / ₂	1 ¹ / ₄ K-hole & smaller, 1 ¹ / ₂ 1 ¹ / ₈ thru 1 ³ / ₈ K-hole and larger, 2	3 ³ / ₄	6 or less 6 ¹ / ₂ or more	36 ³ / ₈ 41 ¹ / ₂	3 ¹ / ₄ + TT	1 ¹ / ₂	1 ³ / ₄
50-63	46 ⁷ / ₈	28 ³ / ₈	8 ⁵ / ₁₆	5 ⁷ / ₈	4	•	18	11 ¹ / ₄	3	1 ¹⁵ / ₁₆ K-hole, 1 ¹ / ₂ 1 ¹ / ₈ thru 1 ³ / ₈ K-hole, 2 1 ¹ / ₂ K-hole and larger, 3	1	11 or less 11 ¹ / ₂ or more	52 ¹ / ₂ 57 ³ / ₄	4 ¹ / ₄ + TT	3 ³ / ₄	2 ¹ / ₄
64-74	68	36 ³ / ₄	1 ³ / ₁₆	7 ¹ / ₂	5	25 ³ / ₈	22 ³ / ₁₆	11	3 ³ / ₄	3	1 ¹ / ₂	10 ¹ / ₂ or less 11 or more	77 ¹ / ₄ 77 ³ / ₈	5 ³ / ₄ + TT	1 ¹ / ₄	2 ³ / ₄
75-83	69 ¹ / ₂	37 ¹ / ₄	1 ¹ / ₂	7 ¹ / ₂	6 ¹ / ₄	25 ³ / ₈	27 ¹⁵ / ₁₆	11	3 ³ / ₄	3 ³ / ₄	1	10 ¹ / ₂ or less 11 or more	77 ¹⁵ / ₁₆ 78 ¹ / ₁₆	5 ³ / ₄ + TT	1 ¹ / ₂	3 ³ / ₄ *
84-110	See page 174															

Rod take-out = (factor) - (TT / 2), for lever in high position. • "I" dimension for sizes 10 through 63 equals "B" + "Q"

Note: See the size selection chart (page 164 through 167) for the "B" dimension. K hole center line location is determined by the formula of "B - G = K Center Line".

Load (lbs)	0 800	801 1,500	1,501 2,540	2,541 4,000	4,001 6,100	6,101 9,400	9,401 13,400	13,401 18,300	18,301 24,700	24,701 31,000	31,001 39,000	39,001 48,000	48,001 58,000
J-Rod Size	1 ¹ / ₂	5 ⁵ / ₈	3 ³ / ₄	1	1 ¹ / ₄	1 ¹ / ₂	1 ³ / ₄	2	2 ¹ / ₄	2 ¹ / ₂	2 ³ / ₄	3	3 ¹ / ₄ *
K-Hole Size	1 ¹¹ / ₁₆	1 ¹³ / ₁₆	1 ¹⁵ / ₁₆	1 ¹ / ₄	1 ¹ / ₂	1 ³ / ₄	2	2 ³ / ₈	2 ⁵ / ₈	2 ⁷ / ₈	3 ¹ / ₈	3 ³ / ₈	3 ⁵ / ₈
S	7 ⁷ / ₈	1 ¹ / ₁₆	1 ¹ / ₄	1 ¹ / ₈	2	2 ³ / ₈	2 ⁵ / ₈	2 ⁷ / ₈	3 ¹ / ₈	3 ³ / ₈	3 ⁵ / ₈	3 ⁷ / ₈	4 ¹ / ₈

* 3¹/₄" is furnished with 4 UNC series thread.

Fig. 80-V Type D

Model R

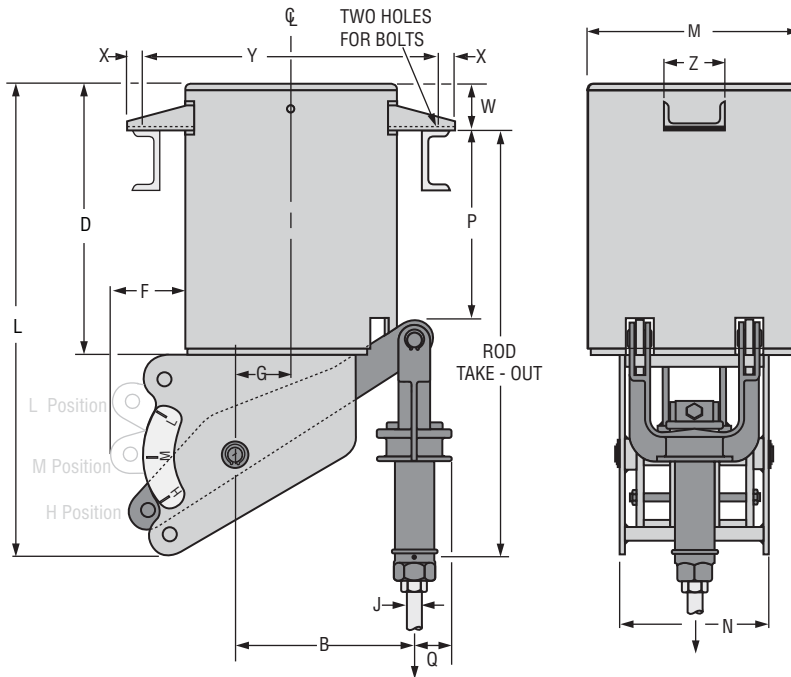

Type D rests on top of structural steel while most of the Constant Support itself hangs between or below the supporting beams. The depth of the beam is limited by the “P” dimension. Dimension “P” can be varied on special order, however, “P” dimension shown is maximum for the hanger.

Notes: See load travel tables, page 164 through 167 for “B” dimension. For weights see page 182. Location of travel indicator and contour of side plate may vary from that shown.

FIG. 80-V: DIMENSIONS (IN)

Hanger Sizes	L	D	F	G	Dia. M	N	Q	P	W	X	Y	Z	Bracket Hole Dia.	Total Travel TT	Factors	J-Rod		
																Min Thd Length	Min Dia.	Max Dia.
1-9	Available in Fig. 81-H only																	
10-18	18 ⁷ / ₈	8 ⁷ / ₈	2	1 ¹ / ₂	8 ⁵ / ₈	6 ⁷ / ₁₆	1 ³ / ₈	4 ¹⁵ / ₁₆	2 ³ / ₈	1 ¹ / ₂	10 ³ / ₄	3	3/4	5 or less 5 ¹ / ₂ or more	15 ¹ / ₂ 17 ³ / ₁₆	1 ³ / ₄ + TT	1/2	3/4
19-34	28 ¹ / ₂	16	2 ¹ / ₂	2 ⁵ / ₈	12 ³ / ₄	8 ⁹ / ₁₆	1 ³ / ₈	12 ¹ / ₂	2 ³ / ₈	1 ¹ / ₂	14 ⁷ / ₈	3	7/8	5 or less 5 ¹ / ₂ or more	26 ¹¹ / ₁₆ 28 ¹³ / ₁₆	2 ³ / ₈ + TT	1/2	1 ¹ / ₄
35-49	32 ³ / ₄	18 ¹ / ₄	4 ³ / ₄	3 ³ / ₄	14	9 ¹ / ₁₆	2 ¹ / ₂	13 ¹ / ₄	2 ⁵ / ₈	2	16 ³ / ₄	4	1 ¹ / ₈	6 or less 6 ¹ / ₂ or more	31 ¹ / ₄ 35 ⁵ / ₈	3 ¹ / ₄ + TT	1/2	1 ³ / ₄
50-63	46 ⁷ / ₈	28 ¹ / ₈	8 ⁵ / ₁₆	5 ⁷ / ₈	18	11 ¹ / ₄	3	24 ¹ / ₂	2 ⁷ / ₈	3	21	6	1 ³ / ₈	11 or less 11 ¹ / ₂ or more	45 ⁹ / ₁₆ 50 ⁵ / ₈	4 ¹ / ₄ + TT	3/4	2 ¹ / ₄
64-83	Available in Fig. 81-H only.																	
84-110	Not Available																	

*Rod take-out = (factor) - (TT / 2), for lever in high position. • “l” dimension for sizes 10 through 63 equals “B” + “Q”
Note: See the size selection chart (page 164 through 167) for the “B” dimension.

Load (lbs)	0 800	801 1,500	1,501 2,540	2,541 4,000	4,001 6,100	6,101 9,400	9,401 13,400	13,401 18,300	18,301 24,700
J Rod Size	1/2	5/8	3/4	1	1 1/4	1 1/2	1 3/4	2	2 1/4

CONSTANT SUPPORTS

Fig. 80-V Type E

Model R

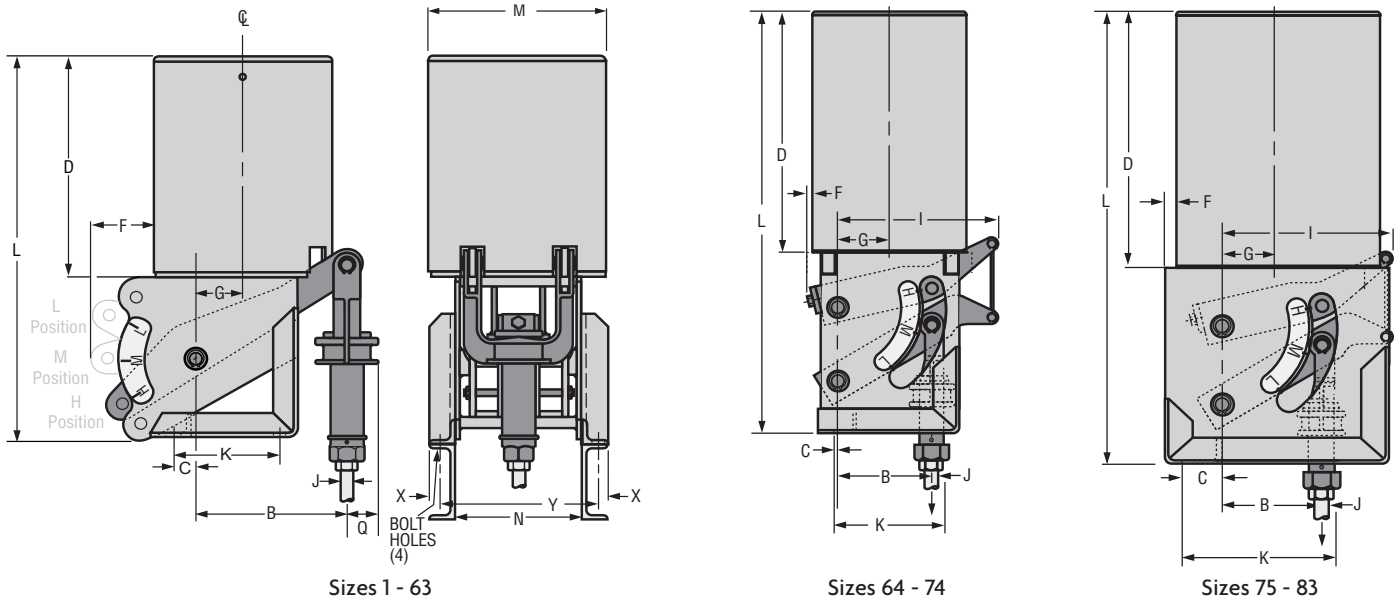

Type E rests on top flange of structural steel and the constant support itself is entirely above the supporting beams. If the rod takeout does not exceed the depth of the supporting steel and the rod coupling must extend below the steel, specify the depth of the supporting steel. Increase the rod take-out by the depth of the steel.

Notes: See load travel tables, page 164 through 167 for "B" dimension. For weights see page 182. Location of travel indicator and contour of side plate may vary from that shown.

FIG. 80-V, TYPE E: DIMENSIONS (IN)

Hanger Size	L	C	D	F	G	I	K	Dia. M	X	Y	N	Q	Angle Size	Bracket Hole Dia.	Total Travel TT	Factors	J-Rod		
																	Min Thd Length	Rod Dia Min	Max
1-9	Available in Fig. 81-H Only																		
10-18	18 ⁷ / ₈	1 ¹ / ₂	8 ⁷ / ₈	2	1 ¹ / ₂	•	4 ⁵ / ₁₆	8 ⁵ / ₈	5 ⁸ / ₈	8 ¹⁵ / ₁₆	6 ⁷ / ₁₆	1 ³ / ₈	1 ¹ / ₂ x 2 x 1 ¹ / ₄	3 ⁴ / ₈	5 or less 5 ¹ / ₂ or more	1 ⁷ / ₁₆ 3 ³ / ₄	1 ³ / ₄ + TT	1 ¹ / ₂	3 ⁴ / ₈
19-34	28 ¹ / ₂	1 ³ / ₁₆	16	2 ¹ / ₈	2 ⁵ / ₈	•	6 ¹¹ / ₁₆	12 ³ / ₄	5 ⁸ / ₈	11 ³ / ₁₆	8 ⁹ / ₁₆	1 ⁵ / ₈	1 ¹ / ₂ x 2 ¹ / ₂ x 1 ¹ / ₄	3 ⁴ / ₈	5 or less 5 ¹ / ₂ or more	2 ¹³ / ₁₆ 4 ¹⁵ / ₁₆	2 ³ / ₈ + TT	1 ¹ / ₂	1 ¹ / ₄
35-49	32 ³ / ₄	1 ⁷ / ₈	18 ¹ / ₄	4 ³ / ₄	3 ³ / ₄	•	8 ⁵ / ₁₆	14	1 ³ / ₁₆	13 ⁵ / ₁₆	9 ¹³ / ₁₆	2 ¹ / ₂	3 x 2 x 3 ⁸ / ₈	7 ⁸ / ₈	6 or less 6 ¹ / ₂ or more	2 ¹ / ₂ 7 ¹ / ₈	3 ¹ / ₄ + TT	1 ¹ / ₂	1 ³ / ₄
50-63	46 ⁷ / ₈	3 ³ / ₄	28 ¹ / ₈	8 ⁵ / ₁₆	5 ⁷ / ₈	•	12 ¹³ / ₁₆	18	1 ⁵ / ₁₆	14 ¹¹ / ₁₆	11 ¹ / ₄	3	3 x 3 x 3 ⁸ / ₈	1 ³ / ₈	11 or less 11 ¹ / ₂ or more	1 ⁵ / ₈ 7	4 ¹ / ₄ + TT	3 ⁴ / ₈	2 ¹ / ₄
64-74	62	3 ⁸ / ₈	35 ³ / ₄	3 ⁸ / ₈	7 ¹ / ₂	25 ³ / ₈	15 ³ / ₄	22 ³ / ₁₆	1 ⁹ / ₁₆	14 ¹⁵ / ₁₆	11	3	3 ¹ / ₂ x 3 ¹ / ₂ x 1 ¹ / ₂	1 ⁵ / ₈	10 ¹ / ₂ or less 11 or more	9 ¹ / ₈ 9 ¹ / ₄	5 ³ / ₄ + TT	1 ¹ / ₄	2 ³ / ₄
75-83	62 ¹ / ₂	5 ¹ / ₄	35 ³ / ₄	1 ¹ / ₂	7 ¹ / ₂	25 ³ / ₈	25 ³ / ₈	27 ³ / ₁₆	1 ¹ / ₄	15 ¹ / ₂	11	3	4 x 4 x 3 ⁸ / ₈	1 ⁵ / ₈	10 ¹ / ₂ or less 11 or more	8 ³ / ₄ 8 ⁷ / ₈	5 ³ / ₄ + TT	1 ¹ / ₂	3 ¹ / ₄
84-110	Not Available																		

Rod take-out = (factor) - (TT / 2), for lever in high position. Rod take-out is measured from the bottom of the supporting angles to the center of the load coupling site hole.
 • "I" dimension for sizes 10 through 63 equals "B" + "Q" Note: See the size selection chart (page 164 through 167) for the "B" dimension.

J-ROD SELECTION CHART

Load (lbs)	0 800	801 1,500	1,501 2,540	2,541 4,000	4,001 6,100	6,101 9,400	9,401 13,400	13,401 18,300	18,301 24,700	24,701 31,000	31,001 39,000	39,001 48,000	48,001 58,000
J Rod Size	1/2	5/8	3/4	1	1 1/4	1 1/2	1 3/4	2	2 1/4	2 1/2	2 3/4	3	3 1/4*

* 3 1/4" is furnished with 4 UNC series thread.

Fig. 80-V Type G

Model R

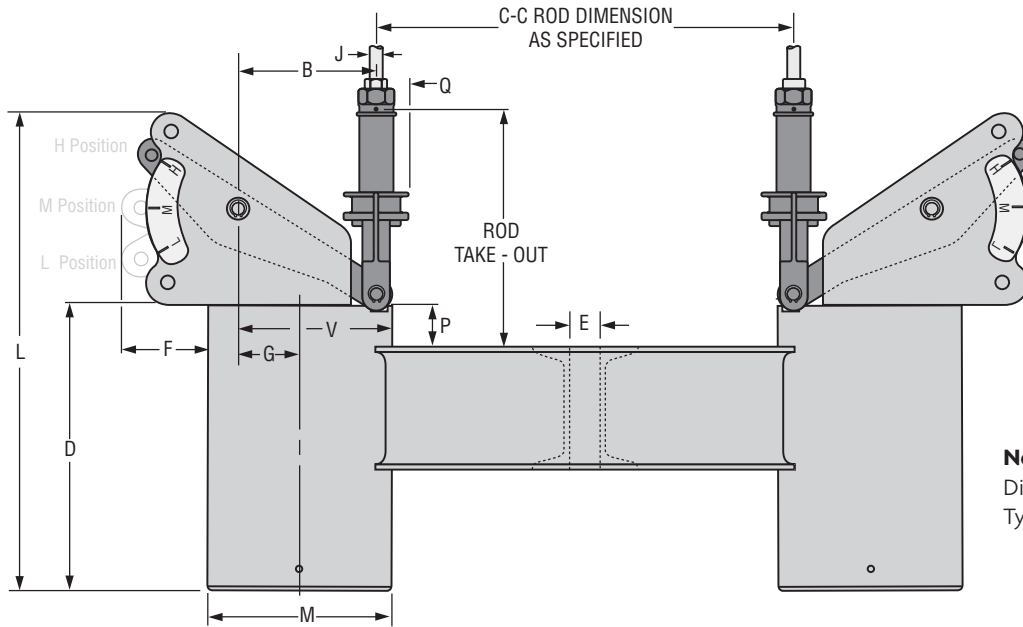

Note: For orientation of "N" Dimension, see Fig. 80-V Type D on page 171.

Type G is a complete trapeze assembly. The hanger consists of two vertical type Constant Support units plus a pair of channels, back-to-back, welded at each end to the hanger casing. In sizing a Type G hanger, it must be remembered that each standard spring unit carries one-half of the total pipe load. Furthermore, the weights of the hanger itself must be considered as part of the overall load. Therefore, using one-half the total pipe load, select the required hanger size from the Load Travel Table and add one-half the weight of the size hanger selected to one-half the total pipe load. If the load now exceeds the maximum load at the required total travel for the hanger size selected, it is necessary to go to the next larger hanger. If the pipe line is designed so as not to be centered on the channel, one

spring of the trapeze will carry a heavier load than the other and care must be taken in sizing the individual hanger units. The center-to-center rod dimension must be specified when ordering. The minimum C-C dimension can be determined as follows:

$$B \text{ plus } Q > Y: (\text{O.D. of pipe covering}) + 2Q.$$

$$B \text{ plus } Q < Y: (\text{O.D. of pipe covering}) + 2(Y - B).$$

Note: If U-bolt is used to fasten pipe to channels, C-C of U-bolt tangents plus one washer plate width cannot be greater than C-C of the hanger rods minus 2 (V minus B). See load travel tables, page 164 through 167 for "B" dimension.

For weights see page 182. Location of travel indicator and contour of side plate may vary from that shown.

FIG. 80-V, TYPE G: DIMENSIONS (IN)

Hanger Size	L	D	E	F	G	Dia M	N	P	Q	V	Y	Channel Size (lbs/ft)	C - C	Total Travel TT	Factors	J-Rod		
																Min Thread Length	Min Rod. Dia.	Max Rod Dia.
1-9	Not available																	
10-18	18 ⁷ / ₈	8 ⁷ / ₈	1	2	1 ¹ / ₂	8 ⁵ / ₈	6 ⁷ / ₁₆	2 ⁹ / ₁₆	3 ¹ / ₂	5 ¹³ / ₁₆	3 ¹⁵ / ₁₆	4 @ 5.4	30	5 or less 5 ¹ / ₂ or more	11 ¹¹ / ₁₆ 14	1 ³ / ₄ + TT	1/2	3/4
19-34	28 ¹ / ₂	16	1 ¹ / ₄	2 ¹ / ₈	2 ⁵ / ₈	12 ³ / ₄	8 ⁹ / ₁₆	3 ⁹ / ₁₆	4	9	6 ¹ / ₈	6 @ 10.5	42	5 or less 5 ¹ / ₂ or more	16 ¹³ / ₁₆ 18 ³ / ₄	2 ³ / ₈ + TT	1/2	1 ¹ / ₄
35-49	32 ³ / ₄	18 ¹ / ₄	1 ¹ / ₂	4 ³ / ₄	3 ³ / ₄	14	9 ¹³ / ₁₆	3 ⁷ / ₁₆	5 ¹ / ₂	10 ³ / ₄	8	10 @ 15.3	48	6 or less 6 ¹ / ₂ or more	19 ¹ / ₄ 23 ³ / ₈	3 ¹ / ₄ + TT	1/2	1 ³ / ₄
50-63	46 ⁷ / ₈	28 ¹ / ₈	2 ¹ / ₈	8 ⁵ / ₁₆	5 ⁷ / ₈	18	11 ¹ / ₄	4	6 ¹ / ₂	14 ³ / ₄	10 ¹⁵ / ₁₆	12 @ 20.7	48	11 or less 11 ¹ / ₂ or more	24 ⁵ / ₈ 30	4 ¹ / ₄ + TT	3/4	2 ¹ / ₄
64-110	Not available																	

Rod take-out = (factor) - (TT / 2), for lever in high position.

Note: See the size selection chart (see page 164 through 167) for the "B" dimension.

Load (lbs)	0 800	801 1,500	1,501 2,540	2,541 4,000	4,001 6,100	6,101 9,400	9,401 13,400	13,401 18,300	18,301 24,700
J Rod Size	1/2	5/8	3/4	1	1 1/4	1 1/2	1 3/4	2	2 1/4

CONSTANT SUPPORTS

Fig. 80-V Types A, B and C

Model R, Sizes 84 to 110

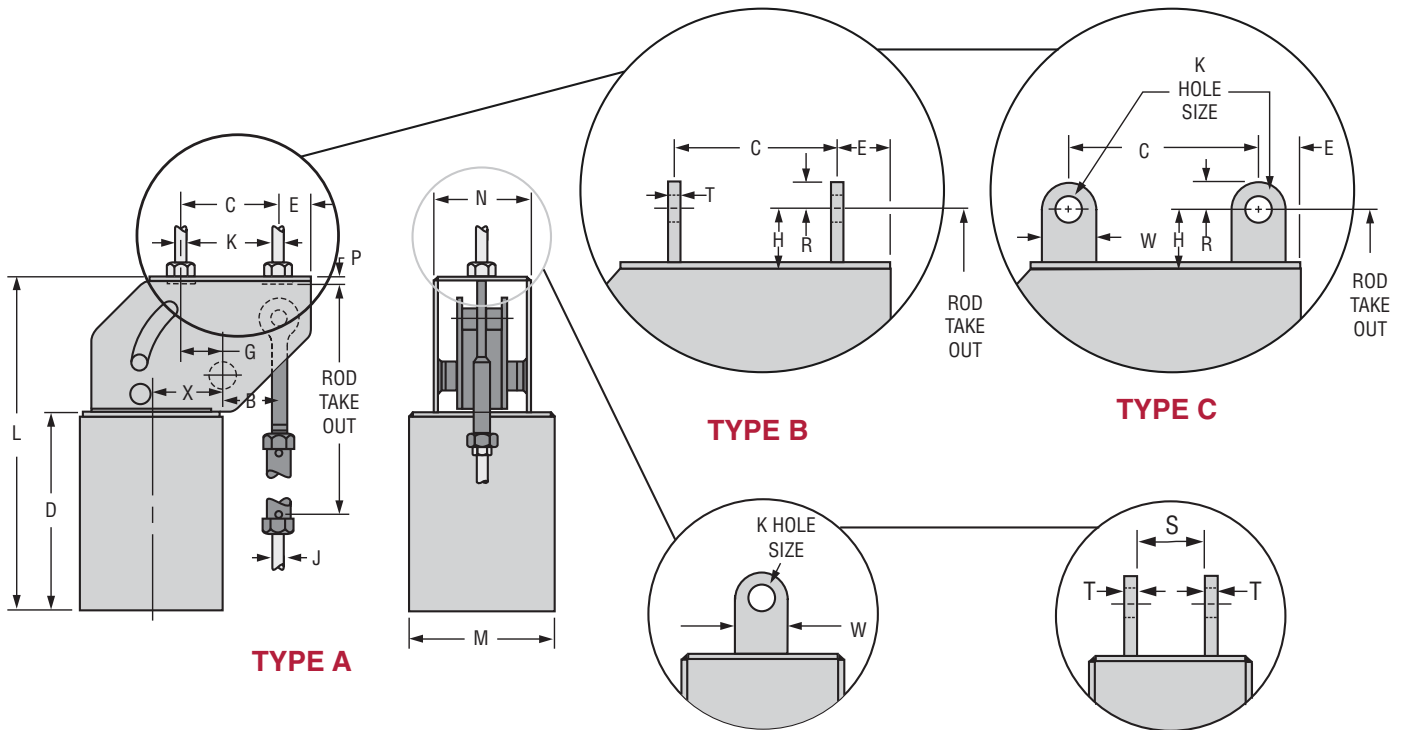

Note: "B" Dimension is a function of total travel ("G" + "B" should not be assumed as equal to "C" Dimension)

Types A, B, and C sizes 84 through 110, for large loads and long travels, provide for basically the same methods of upper attachment as sizes 10 to 83 shown Type A on page 168, Type B page 169 and Type C see page 170.

Notes: See load travel tables, page 164 through 167 for "B" dimension. For weights see page 182.

FIG. 80-V, TYPES A,B,C SIZES 84 TO 110: DIMENSIONS (IN)

Hanger Sizes	L	C		D	E		G		H	M	N	P	X	Total Travel TT	Factor		J - Rod		
		Type A & B	Type C		Type A & B	Type C	Type A & B	Type C							Type A	Type B & C	Min Thread Length	Rod Dia.	
		Min	Max																
84-94	78¾	16	15	49¾	4	4½	1½	1	6	24	10½	3	12	9½ or less	45¾	54¾	10	2	¾
														10 or more	55½	64½			
95-110	100	24	23	64	4	4½	7½	7	6	24	11½	3½	13½	14 or less	51⅞	60⅞	12	2½	¾
														14½ or more	60⅞	69⅞			

*Rod take-out = (factor) - (.75 x TT), for Lever in high position
 Note: See the size selection chart (page 164 through 167) for the "B" dimension.

Load (lbs)	14,376 18,300	18,301 24,700	24,701 31,000	31,001 39,000	39,001 48,000	48,001 58,000	58,001 69,000	69,001 87,500
J & K-Rods	2	2¼	2½	2¾	3	3¼*	3½*	3¾*
K-Hole	2⅜	2⅝	2⅞	3⅛	3⅜	3⅝	3⅞	4⅞
R	3	3	4	4	4	4½	4½	4½
S	2⅞	3⅞	3⅞	3⅝	3⅞	4⅞	4⅞	4⅞
T (Type B)	¾	¾	1	1	1	1	1½	1¼
T (Type C)								
W	6	6	8	8	8	9	9	9

*¾ and larger is furnished with 4 UNC series thread.

Fig. 81-H Type A

Model R

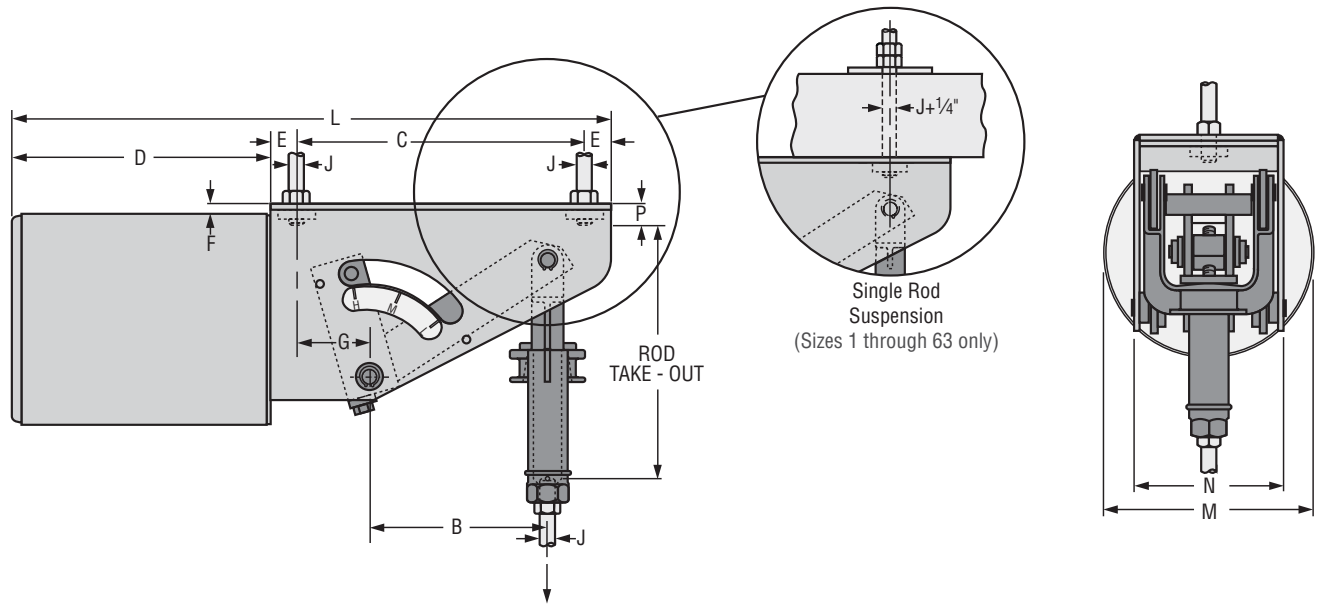

Type A of the Figure 81- H Horizontal Design Model R Constant Support Hanger is designed for attaching to its supporting member by screwing two rods into tapped holes in the top of the hanger from a distance equal to the “P” dimension plus $\frac{3}{8}$ ”. Sizes 1 to 9 are furnished with swivel eye and turnbuckle instead of yoke and coupling.

Notes: Also available for single rod suspension as indicated above. When ordering specify “ for single rod suspension”. See load travel tables, page 164 through 167 for “B” dimension. For weights see page 182. Location of travel indicator and contour of side plate may vary from that shown.

FIG. 81-H TYPE A: DIMENSIONS (IN)

Hanger Sizes	D	E	F	G	M	N	P	Total Travel TT	L	C	Factors	J-Rod		
												Min Thread Length	Rod Dia.	
													Min	Max
1-9	8 $\frac{1}{4}$	1	7 $\frac{7}{8}$	2	6 $\frac{5}{8}$	4 $\frac{7}{8}$	1 $\frac{3}{16}$	4 or less	16 $\frac{1}{4}$	6	12 $\frac{3}{4}$	1 $\frac{3}{4}$ + TT	1/2	1/2
								4 $\frac{1}{2}$ or more	20 $\frac{1}{4}$	10	15 $\frac{5}{16}$			
10-18	8 $\frac{7}{16}$	1	1/2	2 $\frac{9}{16}$	8 $\frac{5}{16}$	6 $\frac{7}{16}$	1 $\frac{1}{16}$	5 or less	18 $\frac{7}{16}$	8	10 $\frac{7}{8}$	1 $\frac{3}{4}$ + TT	1/2	3/4
								5 $\frac{1}{2}$ or more	21 $\frac{7}{16}$	11	13 $\frac{1}{4}$			
19-34	14 $\frac{7}{16}$	1 $\frac{1}{4}$	5/8	3 $\frac{3}{8}$	12 $\frac{7}{16}$	8 $\frac{9}{16}$	1 $\frac{1}{8}$	5 or less	26 $\frac{15}{16}$	10	16 $\frac{3}{4}$	2 $\frac{3}{8}$ + TT	1/2	1 $\frac{1}{4}$
								5 $\frac{1}{2}$ or more	31 $\frac{1}{16}$	14 $\frac{1}{8}$	18 $\frac{3}{8}$			
35-49	17 $\frac{7}{16}$	1 $\frac{3}{4}$	1 $\frac{1}{16}$	4 $\frac{3}{4}$	13 $\frac{3}{4}$	9 $\frac{13}{16}$	1 $\frac{3}{8}$	6 or less	31 $\frac{9}{16}$	11	21 $\frac{1}{8}$	3 $\frac{1}{4}$ + TT	1/2	1 $\frac{3}{4}$
								6 $\frac{1}{2}$ or more	39 $\frac{9}{16}$	19	25 $\frac{3}{4}$			
50-63	26 $\frac{3}{16}$	1 $\frac{11}{16}$	1 $\frac{5}{16}$	7 $\frac{11}{16}$	17 $\frac{11}{16}$	11 $\frac{1}{4}$	1 $\frac{3}{4}$	8 or less	45 $\frac{9}{16}$	16	24 $\frac{15}{16}$	4 $\frac{1}{4}$ + TT	3/4	2 $\frac{1}{4}$
								8 $\frac{1}{2}$ to 11	53 $\frac{9}{16}$	24	24 $\frac{15}{16}$			
								11 $\frac{1}{2}$ or more	53 $\frac{9}{16}$	24	30 $\frac{1}{4}$			
64-74	35 $\frac{3}{4}$	3	3 $\frac{3}{4}$	5 $\frac{1}{4}$	22 $\frac{3}{16}$	11	3 $\frac{7}{16}$	10 $\frac{1}{2}$ or less	57 $\frac{1}{2}$	15 $\frac{3}{4}$	34 $\frac{7}{16}$	5 $\frac{3}{4}$ + TT	1 $\frac{1}{4}$	2 $\frac{3}{4}$
								11 or more	63	21 $\frac{1}{4}$	34 $\frac{9}{16}$			
75-83	35 $\frac{3}{4}$	3 $\frac{3}{4}$	3 $\frac{5}{8}$	5	27 $\frac{3}{16}$	11	4 $\frac{1}{4}$	10 $\frac{1}{2}$ or less	57 $\frac{1}{2}$	15 $\frac{1}{4}$	36 $\frac{1}{2}$	5 $\frac{3}{4}$ + TT	1 $\frac{1}{2}$	3 $\frac{1}{4}$
								11 or more	63	20 $\frac{3}{4}$	36 $\frac{5}{8}$			
84-110	See page 181													

*Rod take-out = (factor)-(TT / 2) for lever in high position.

J-ROD SELECTION CHART

Load (lbs)	0 800	801 1,500	1,501 2,540	2,541 4,000	4,001 6,100	6,101 9,400	9,401 13,400	13,401 18,300	18,301 24,700	24,701 31,000	31,001 39,000	39,001 48,000	48,001 58,000
Rod Size	1/2	5/8	3/4	1	1 $\frac{1}{4}$	1 $\frac{1}{2}$	1 $\frac{3}{4}$	2	2 $\frac{1}{4}$	2 $\frac{1}{2}$	2 $\frac{3}{4}$	3	3 $\frac{1}{4}$ *

* 3 $\frac{1}{4}$ " is furnished with 4 UNC series thread.

CONSTANT SUPPORTS

Fig. 81-H Type B

Model R

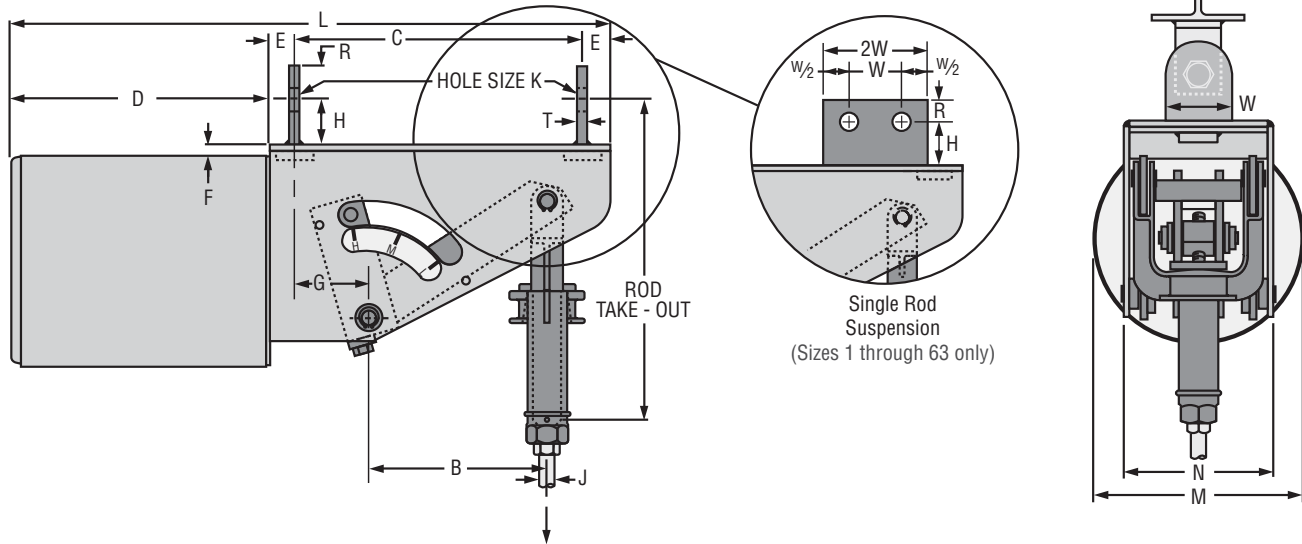

Type B is furnished with two lugs – one at each end of the hanger frame. These lugs permit use of Fig. 66 welded beam attachments, clevises or angle clips for attachment where headroom is limited. Sizes 1 to 9 are furnished with swivel eye and turnbuckle instead of yoke and coupling.

Notes: Also available for single rod suspension as indicated above. When ordering specify “for single rod suspension.” See load travel tables, page 164 through 167 for “B” dimension. For weights see page 182. Location of travel indicator and contour of side plate may vary from that shown.

FIG. 81-H TYPE B: DIMENSIONS (IN)

Hanger Sizes	D	E	F	G	H	M	N	Total Travel TT	L	C	Factors	J-Rod		
												Min Thd Length	Rod Dia.	
												Min	Max	
1 - 9	8¼	1¼	7⁄8	1¾	1½	6⅞	4⅞	4 or less	16¼	5½	14⅝	1¾ + TT	½	½
								4½ or more	20¼	9½	17¾			
10 - 18	8⅞	1¼	½	2⅝	1½	8⅝	6⅞	5 or less	18⅞	7½	13⅞	1¾ + TT	½	¾
								5½ or more	21¼	10½	15⅞			
19 - 34	14⅞	1⅜	5⁄8	3¾	2	12⅞	8⅞	5 or less	26⅝	9¾	19⅞	2⅝ + TT	½	1¼
								5½ or more	31⅞	13⅞	22			
35 - 49	16⅞	2	1⅞	4½	3	13¾	9⅞	6 or less	31⅞	10½	25⅝	3¼ + TT	½	1¾
								6½ or more	39⅞	18½	30⅞			
50 - 63	26⅞	3	1⅞	6⅞	4	17⅞	11¼	8 or less	45⅞	13⅞	30⅞	4¼ + TT	¾	2¼
								8½ to 11	53⅞	21⅞	30⅞			
64 - 74	35¾	¾	¾	5	4½	22⅞	11	11½ or more	53⅞	21⅞	36	5¼ + TT	1¼	2¾
								10½ or less	57½	15¼	42⅞			
75 - 83	35¾	¾	3⅝	4¾	5	27⅞	11	10½ or less	57½	14¾	45¾	5¼ + TT	1½	3¼**
								11 or more	63	20¼	45⅞			
84 - 110	See page 181													

* Rod take-out = (factor) - (TT / 2), for lever in high position.

J-ROD AND K-HOLE SELECTION CHART

Load (lbs)	0 800	801 1,500	1,501 2,540	2,541 4,000	4,001 6,100	6,101 9,400	9,401 13,400	13,401 18,300	18,301 24,700	24,701 31,000	31,001 39,000	39,001 48,000	48,001 58,000
J-rod	½	5⁄8	¾	1	1¼	1½	1¾	2	2¼	2½	2¾	3	3¼**
K-Hole Size	1⅞	1⅞	1⅞	1¼	1½	1¾	2	2⅞	2⅞	2⅞	3⅞	3⅞	3⅞
R	1¼	1¼	1¼	1½	2	2½	2½	3	3	4	4	4	4½
T	¼*	¼*	3⁄8	½	5⁄8	¾	¾	¾	¾	1	1	1	1
W	2½	2½	2½	3	4	5	5	6	6	8	8	8	9

* ¾" for single rod suspension ** 3¼" is furnished with 4 UNC series thread.

Fig. 81-H Type C

Model R

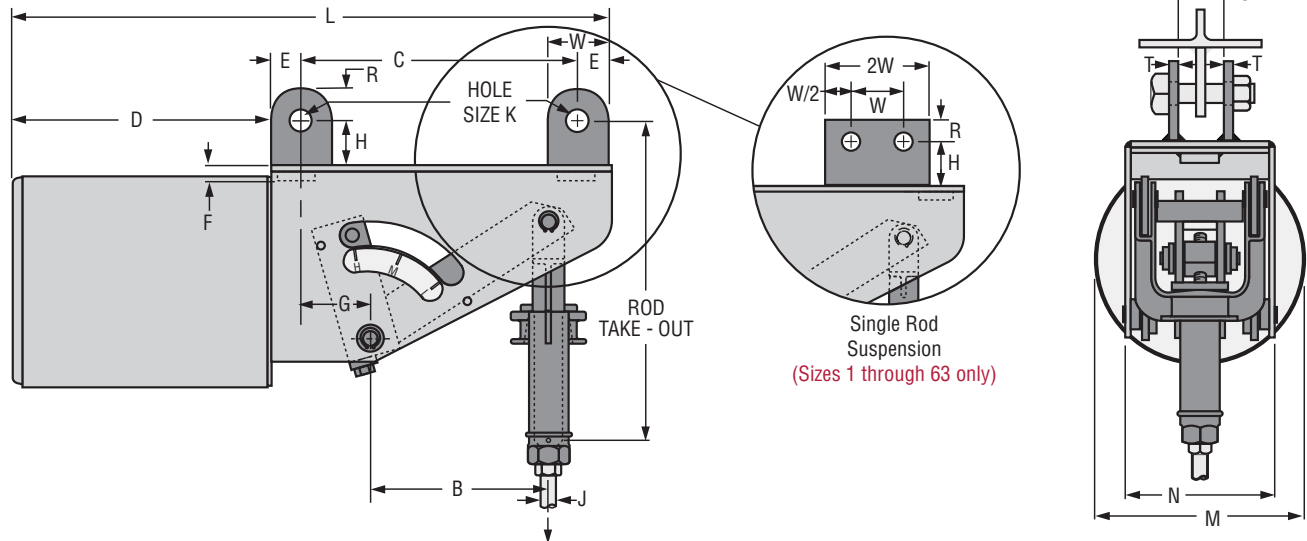

Type C is furnished with two pair of lugs, one pair of lugs at each of the hanger frame. These lugs permit the use of two eye rods or two single plates for attachment where headroom is limited. Sizes 1 to 9 are furnished with swivel eye and turnbuckle instead of yoke and coupling.

Notes: Also available for single rod suspension as indicated above. When ordering specify "for single rod suspension." See load travel tables, page 164 through 167 for "B" dimension. For weights see page 182. Location of travel indicator and contour of side plate may vary from that shown.

FIG. 81-H TYPE C: DIMENSIONS (INCHES)

Hanger Sizes	D	E	F	G	H	M	N	Total Travel TT	L	C	Factors	J-Rod		
												Min Thd Length	Rod Dia.	
												Min	Max	
1 - 9	8¼	1¼	7/8	1¼	1½	6⅞	4⅞	4 or less	16¼	5½	14⅞	1¼ + TT	½	½
								4½ or more	20¼	9½	17⅞			
10 - 18	8⅞	1¼	½	2⅞	1½	8⅞	6⅞	5 or less	18⅞	7½	13⅞	1¼ + TT	½	¾
								5½ or more	21⅞	10½	15⅞			
19 - 34	14⅞	2	5/8	3⅞	2	12⅞	8⅞	5 or less	26⅞	8½	19⅞	2⅞ + TT	½	1¼
								5½ or more	31⅞	12⅞	22			
35 - 49	17⅞	2½	1⅞	4	3	13¾	9⅞	6 or less	31⅞	9½	25⅞	3¼ + TT	½	1¾
								6½ or more	39⅞	17½	30⅞			
50 - 63	26⅞	3	1⅞	6⅞	4	17⅞	11¼	8 or less	45⅞	13⅞	30⅞	4¼ + TT	¾	2¼
								8½ to 11	53⅞	21⅞	36			
64 - 74	35¾	4	3¼	4¼	4½	22⅞	11	10½ or less	57½	13¾	42⅞	5¾ + TT	1¼	2¾
								11 or more	63	19¼	42½			
75 - 83	35¾	4½	3⅞	3¾	5	27⅞	11	10½ or less	57½	12¾	45¾	5¾ + TT	1½	3¼
								11 or more	63	18¼	45¾			

84 - 110 See page 181

* Rod take-out = (factor) - (TT / 2), for lever in high position.

J-ROD AND K-HOLE SELECTION CHART

Load (lbs)	0 800	801 1,500	1,501 2,540	2,541 4,000	4,001 6,100	6,101 9,400	9,401 13,400	13,401 18,300	18,301 24,700	24,701 31,000	31,001 39,000	39,001 48,000	48,001 58,000
J-Rod	½	5/8	¾	1	1¼	1½	1¾	2	2¼	2½	2¾	3	3¼**
K-Hole Size	1⅞	1⅞	1⅞	1¼	1½	1¾	2	2⅞	2⅞	2⅞	3⅞	3⅞	3⅞
R	1¼	1¼	1¼	1½	2	2½	2½	3	3	4	4	4	4½
S	7/8	1⅞	1¼	1⅞	2	2⅞	2⅞	2⅞	3⅞	3⅞	3⅞	3⅞	4⅞
T	¼*	¼*	3/8	½	5/8	¾	¾	¾	¾	1	1	1	1
W	2½	2½	2½	3	4	5	5	6	6	8	8	8	9

* ¾" for single rod suspension ** 3¼" is furnished with 4 UNC series thread.



CONSTANT SUPPORTS

Fig. 81-H Type D

Model R

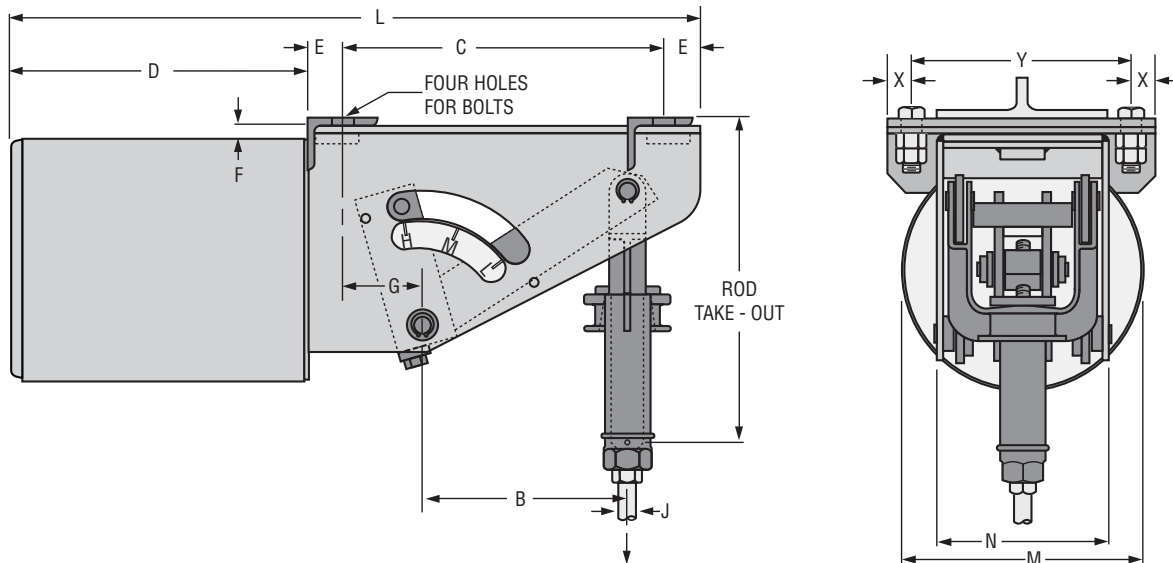

Type D may be bolted directly under steel. Sizes 1 to 9 are furnished with swivel eye and turnbuckle instead of yoke and coupling.

Notes: See load travel tables, page 164 through 167 for "B" dimension. For weights see page 182. Location of travel indicator and contour of side plate may vary from that shown.

FIG. 81-H TYPE D: DIMENSIONS (INCHES)

Hanger Sizes	D	E	F	G	M	N	X	Y	Angle Size	Bracket Hole Dia.	Total Travel TT	L	C	Factors	J-Rod		
															Min Thd Length	Rod Dia.	
															Min	Max	
1 - 9	8 ³ / ₄	1	7 ⁷ / ₈	2	6 ⁵ / ₈	4 ¹ / ₂	3 ³ / ₄	5 ⁵ / ₈	2 x 2 x 1 ¹ / ₄	9 ¹ / ₁₆	4 or less	16 ¹ / ₄	6	13 ³ / ₈	1 ³ / ₄ + TT	1/2	1/2
											4 ¹ / ₂ or more	20 ¹ / ₄	10	15 ¹⁵ / ₁₆			
10 - 18	8 ⁷ / ₁₆	3 ¹ / ₄	1/2	2 ⁹ / ₁₆	8 ⁵ / ₁₆	6 ⁷ / ₁₆	7 ⁷ / ₈	8 ¹ / ₁₆	1 ¹ / ₂ x 1 ¹ / ₂ x 1 ¹ / ₄	3 ³ / ₄	5 or less	18 ⁷ / ₁₆	3 ¹ / ₂	11 ¹³ / ₁₆	1 ³ / ₄ + TT	1/2	3/4
											5 ¹ / ₂ or more	21 ⁷ / ₁₆	6	14 ³ / ₁₆			
19 - 34	14 ⁷ / ₁₆	1 ¹ / ₂	5 ⁵ / ₈	3 ⁵ / ₈	12 ⁷ / ₁₆	8 ⁹ / ₁₆	1 ¹ / ₈	11 ⁵ / ₁₆	3 x 3 ¹ / ₂ x 1 ¹ / ₄	3 ³ / ₄	5 or less	26 ¹⁵ / ₁₆	9 ¹ / ₂	17 ³ / ₄	2 ³ / ₈ + TT	1/2	1 ¹ / ₄
											5 ¹ / ₂ or more	31 ¹ / ₁₆	13 ⁵ / ₈	19 ⁷ / ₈			
35 - 49	17 ¹ / ₁₆	2	1 ¹ / ₁₆	4 ¹ / ₂	13 ³ / ₄	9 ⁹ / ₁₆	1 ³ / ₈	13	3 x 4 x 3 ³ / ₈	7 ⁷ / ₈	6 or less	31 ¹ / ₁₆	10 ¹ / ₂	20 ¹³ / ₁₆	3 ¹ / ₄ + TT	1/2	1 ³ / ₄
											6 ¹ / ₂ or more	39 ⁹ / ₁₆	18 ¹ / ₂	25 ⁷ / ₁₆			
50 - 63	26 ³ / ₁₆	2	1 ⁵ / ₁₆	7 ⁷ / ₈	17 ¹ / ₁₆	11 ¹ / ₄	1 ⁵ / ₈	14 ⁵ / ₈	4 x 4 x 3 ³ / ₈	1 ³ / ₈	8 or less	45 ⁵ / ₁₆	15 ³ / ₈	27 ⁷ / ₁₆	4 ¹ / ₄ + TT	3/4	2 ¹ / ₄
											8 ¹ / ₂ to 11	53 ³ / ₁₆	23 ³ / ₈	27 ⁷ / ₁₆			
											11 or more	53 ³ / ₁₆	23 ³ / ₈	32 ³ / ₈			
64 - 74	35 ³ / ₄	3	3 ³ / ₄	5 ¹ / ₄	22 ³ / ₁₆	11	2	15	4 x 6 x 1 ¹ / ₂	1 ⁵ / ₈	10 ¹ / ₂ or less	57 ¹ / ₂	15 ³ / ₄	38 ³ / ₈	5 ³ / ₄ + TT	1 ¹ / ₄	2 ¹ / ₄
											11 or more	63	21 ¹ / ₄	38 ¹ / ₂			
75 - 83	35 ³ / ₄	3	3 ⁵ / ₈	4 ³ / ₄	27 ³ / ₁₆	11	2	15	4 x 6 x 1 ¹ / ₂	1 ⁵ / ₈	10 ¹ / ₂ or less	57 ¹ / ₂	15 ³ / ₄	41 ¹ / ₄	5 ³ / ₄ + TT	1 ¹ / ₂	3 ¹ / ₄
											11 or more	63	21 ¹ / ₄	41 ³ / ₈			
84 - 110	Not available																

* Rod take-out = factor - (TT / 2), for lever in high position.

J-ROD SELECTION CHART

Load (lbs)	0 800	801 1,500	1,501 2,540	2,541 4,000	4,001 6,100	6,101 9,400	9,401 13,400	13,401 18,300	18,301 24,700	24,701 31,000	31,001 39,000	39,001 48,000	48,001 58,000
J Rod Size	1/2	5/8	3/4	1	1 ¹ / ₄	1 ¹ / ₂	1 ³ / ₄	2	2 ¹ / ₄	2 ¹ / ₂	2 ³ / ₄	3	3 ¹ / ₄ *

*3¹/₄" is furnished with 4 UNC series thread.

Fig. 81-H Type E

Model R

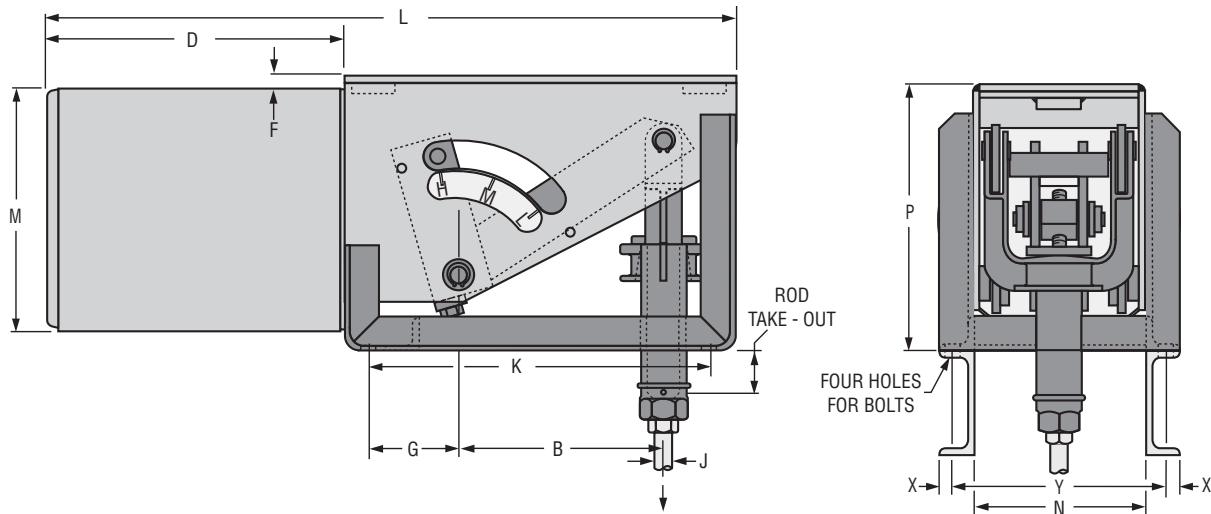

Type E incorporates two brackets as part of its frame, permitting the bolting of the constant support to the top of structural steel. Sizes 1 to 9 are furnished with swivel eye and turnbuckle instead of yoke and coupling. If rod take-out does not exceed the depth of the supporting steel and rod coupling is required to extend below the steel,

specify the depth of the supporting steel. Increase rod take-out by the depth of the steel.

Notes: See load travel tables, page 164 through 167 for "B" dimension. For weights see page 182. Location of travel indicator and contour of side plate may vary from that shown.

FIG. 81-H TYPE E: DIMENSIONS (IN)

Hanger Sizes	D	F	G	M	N	P	X	Y	Angle Size	Bkt. Hole Dia.	Total Travel TT	L	K	Factors	J-Rod		
															Min Thd Length	Rod Dia.	
																Min	Max
1 - 9	8 ¹ / ₄	1 ¹ / ₄	2	6 ¹ / ₈	4 ¹ / ₈	8 ¹ / ₂	5 ⁵ / ₈	5 ¹⁵ / ₁₆	1 ¹ / ₂ x 1 ¹ / ₂ x 1 ¹ / ₄	9 ¹ / ₁₆	4 or less	16 ¹ / ₄	6	5 ⁵ / ₈	1 ³ / ₄ + TT	1 ¹ / ₂	1 ¹ / ₂
											4 ¹ / ₂ or more	20 ¹ / ₄	10	7 ¹ / ₁₆			
10 - 18	8 ⁷ / ₁₆	1	2 ¹ / ₁₆	8 ⁵ / ₁₆	6 ⁷ / ₁₆	11 ⁷ / ₁₆	5 ⁵ / ₈	8 ¹⁵ / ₁₆	1 ¹ / ₂ x 2 x 1 ¹ / ₄	3 ³ / ₄	5 or less	18 ⁷ / ₁₆	7 ¹ / ₂	1 ³ / ₄	1 ³ / ₄ + TT	1 ¹ / ₂	3 ³ / ₄
											5 ¹ / ₂ or more	21 ⁷ / ₁₆	7 ¹ / ₂	4 ¹ / ₁₆			
19 - 34	14 ⁷ / ₁₆	5 ⁵ / ₈	3 ⁵ / ₈	12 ⁷ / ₁₆	8 ⁹ / ₁₆	15 ⁵ / ₈	5 ⁵ / ₈	11 ³ / ₁₆	1 ¹ / ₂ x 2 ¹ / ₂ x 1 ¹ / ₄	3 ³ / ₄	5 or less	26 ¹⁵ / ₁₆	10	3 ³ / ₈	2 ³ / ₈ + TT	1 ¹ / ₂	1 ¹ / ₄
											5 ¹ / ₂ or more	31 ¹ / ₁₆	10	5 ¹ / ₂			
35 - 49	17 ¹ / ₁₆	1 ¹ / ₁₆	4 ¹ / ₂	13 ³ / ₄	9 ¹³ / ₁₆	19 ⁵ / ₈	1 ¹³ / ₁₆	13 ⁵ / ₁₆	3 x 2 x 3 ³ / ₈	7 ⁷ / ₈	6 or less	31 ¹ / ₁₆	11 ⁵ / ₈	4 ⁷ / ₈	3 ³ / ₄ + TT	1 ¹ / ₂	1 ¹ / ₄
											6 ¹ / ₂ or more	39 ⁹ / ₁₆	11 ⁵ / ₈	9 ¹ / ₂			
50 - 63	26 ³ / ₁₆	1 ⁵ / ₁₆	7 ⁷ / ₈	17 ¹¹ / ₁₆	11 ¹ / ₄	19 ³ / ₄	1 ⁵ / ₁₆	14 ¹¹ / ₁₆	3 x 3 x 3 ³ / ₈	1 ³ / ₈	8 or less	45 ⁹ / ₁₆	15 ⁵ / ₈	6 ⁷ / ₈	4 ¹ / ₄ + TT	3 ³ / ₄	2 ¹ / ₄
											8 ¹ / ₂ to 11	53 ⁹ / ₁₆	23 ³ / ₈	6 ⁷ / ₈			
											11 ¹ / ₂ or more	53 ⁹ / ₁₆	23 ³ / ₈	12 ¹ / ₄			
64 - 74	35 ³ / ₄	3 ³ / ₄	5 ¹ / ₄	22 ³ / ₁₆	11	26 ⁷ / ₈	1 ⁹ / ₁₆	14 ¹⁵ / ₁₆	3 ¹ / ₂ x 3 ¹ / ₂ x 1 ¹ / ₂	1 ⁵ / ₈	10 ¹ / ₂ or less	57 ¹ / ₂	17 ¹ / ₂	11 ⁵ / ₈	5 ³ / ₄ + TT	1 ¹ / ₄	2 ¹ / ₄
											11 or more	63	23	11 ¹ / ₄			
75 - 83	35 ³ / ₄	3 ⁵ / ₈	4 ³ / ₄	27 ³ / ₁₆	11	31 ⁷ / ₈	1 ⁹ / ₁₆	14 ¹⁵ / ₁₆	3 ¹ / ₂ x 3 ¹ / ₂ x 1 ¹ / ₂	1 ⁵ / ₈	10 ¹ / ₂ or less	57 ¹ / ₂	17 ¹ / ₂	9	5 ³ / ₄ + TT	1 ¹ / ₂	3 ¹ / ₄
											11 or more	63	23	9 ⁵ / ₈			
84 - 110	Refer to page 181																

* Rod take-out = (factor) - (TT / 2), for lever in high position.

J-ROD SELECTION CHART

Load (lbs)	0 800	801 1,500	1,501 2,540	2,541 4,000	4,001 6,100	6,101 9,400	9,401 13,400	13,401 18,300	18,301 24,700	24,701 31,000	31,001 39,000	39,001 48,000	48,001 58,000
J Rod Size	1/2	5/8	3/4	1	1 1/4	1 1/2	1 3/4	2	2 1/4	2 1/2	2 3/4	3	3 1/4*

*3 1/4" is furnished with 4 UNC series thread.

CONSTANT SUPPORTS

Fig. 81-H Type F Upthrust

Model R

The Upthrust is for support of piping or equipment from below. It has a base flange for fastening to the floor or beams. The load is supported during hydrostatic testing by means of (4) positioning studs. After testing the nuts are moved to either end of the stud to prevent interference during operation. The Upthrust constant support is available for loads up to 24,463 (lbs).

Corrosion resistant units are available either galvanized or carbon-zinc painted or painted with CZ11.

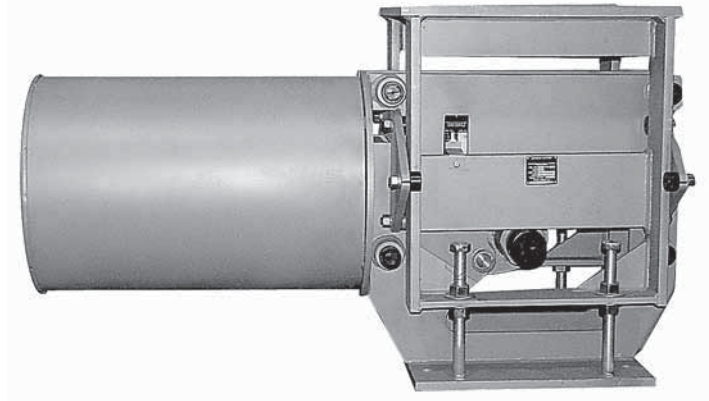

TAKE-OUT FACTOR* "A"				
T.T.	Sizes			
	10 - 18	19 - 34	35 - 49	50 - 63
2.0	16 7/8	23 3/8	-	-
2.5			-	
3.0			-	
3.5			-	
4.0	19 7/8	25 3/4	28 1/2	-
4.5				-
5.0				-
5.5				-
6.0	27 1/2	31 5/8	34	-
6.5				-
7.0				-
7.5				-
8.0	-	-	-	-
8.5	-	-	-	-
9.0	-	-	-	-
9.5	-	-	-	-
10.0	-	-	-	-

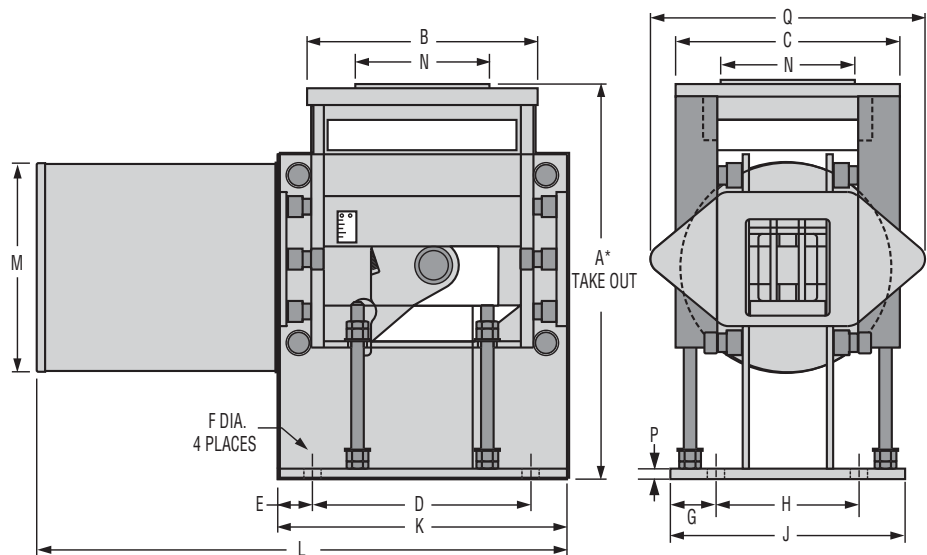

* Note: Shorter "A" Dimensions are available upon request.

* For down travel: Take-Out = "A" + (1/2) Actual Travel
 For up travel: Take-Out = "A" - (1/2) Actual Travel

FIG. 81-H TYPE F: DIMENSIONS (IN)																
Size	Total Travel TT	A	B	C	D	E	F	G	H	J	K	L	M	N	P	Q
10 - 18	2 - 6	See Take Out	10 7/8	11 7/8	9	2 1/2	3/4	2	8	12	14	22 7/16	8 1/4	5	1/2	13 7/8
19 - 34	2 - 8		13 3/4	13 3/4	13	2 1/8			10	14	17 1/4	31 5/8	12 1/2	8	5/8	16 3/8
35 - 49	2 1/2 - 10		17 7/8	16 1/4	17	2	7/8		13	17	21	38 1/4	13 3/8		3/4	19 3/4
50 - 63	3 - 10		21 5/8	19 1/4	16 1/2	6 7/8			3 5/8	11 3/4	19	22 7/16	52	17 7/8		10

Fig. 81-H, Types A, B, C and E

Model R, Sizes 84 to 110

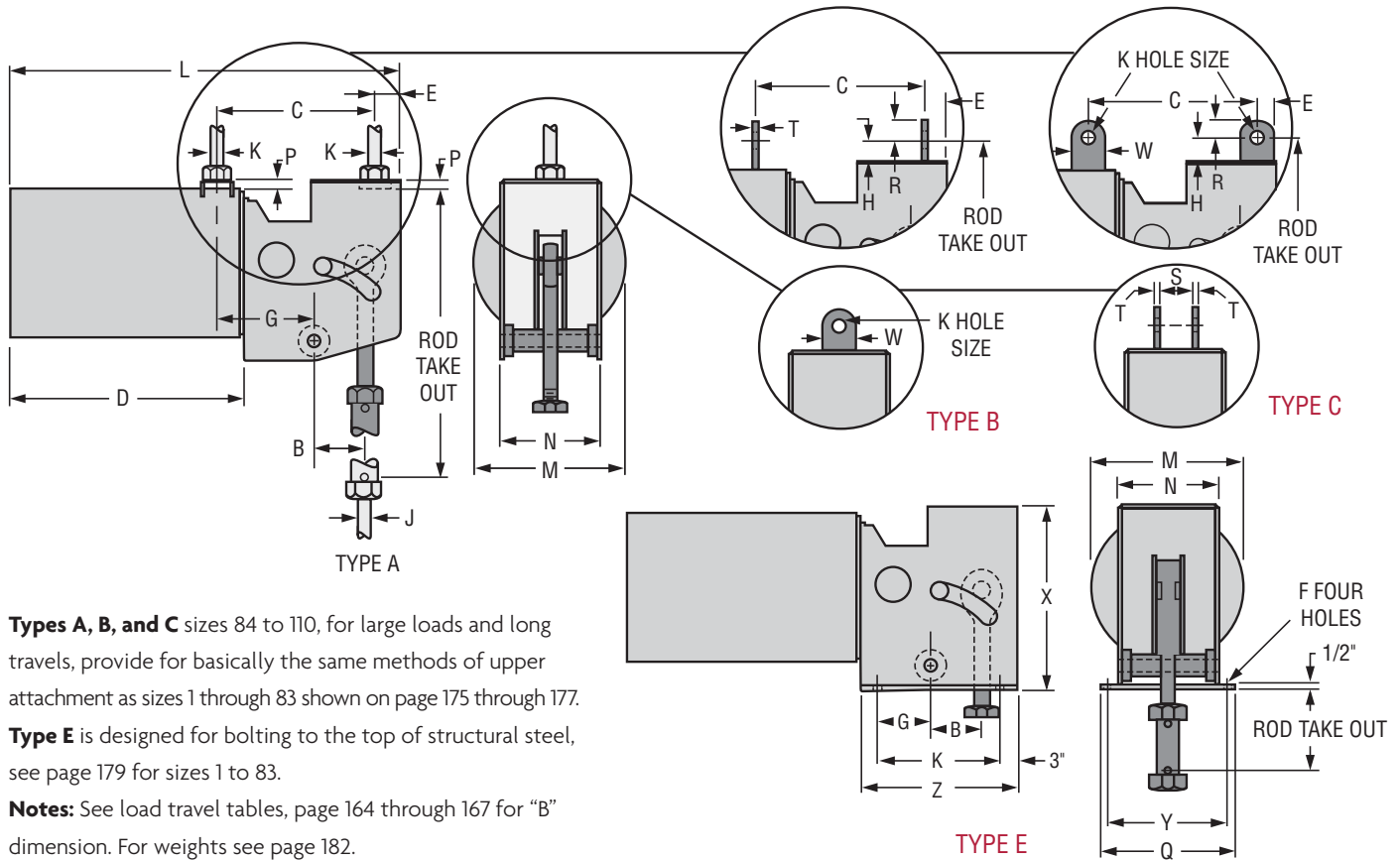

Types A, B, and C sizes 84 to 110, for large loads and long travels, provide for basically the same methods of upper attachment as sizes 1 through 83 shown on page 175 through 177.

Type E is designed for bolting to the top of structural steel, see page 179 for sizes 1 to 83.

Notes: See load travel tables, page 164 through 167 for "B" dimension. For weights see page 182.

FIG. 81-H, TYPES A, B, C AND E: DIMENSIONS (IN)

Hanger Size	L	C		D	E		F	G		H	K	M	N	P	Q	X	Y	Z	Total Travel TT	Factors			J-Rod		
		Type A&B	Type C		Type A&B	Type C		Type A&B & C	Type E											Type A	Type B&C	Type E	Min Thd Lgth	Min	Max
84-94	76 ³ / ₄	28	27 ¹ / ₂	49 ³ / ₄	4	4 ¹ / ₂	1 ¹ / ₈	14	6	6	21	24	10 ¹ / ₂	3	16	34	13	27	9 ¹ / ₂ or less	45 ³ / ₄	54 ³ / ₄	21 ⁵ / ₈	10	2	3 ³ / ₄
																				55 ¹ / ₂	64 ¹ / ₂	31 ³ / ₈	13		
95-110	100	49	48 ¹ / ₂	64	4	4 ¹ / ₂	1 ³ / ₈	28 ³ / ₄	8 ³ / ₄	6	30	24	11 ¹ / ₂	3 ¹ / ₂	17	37	14 ¹ / ₂	36	14 or less	56 ¹ / ₂	66	17 ⁵ / ₈	12		
																			14 ¹ / ₂ or more	65 ³ / ₄	74 ³ / ₄	26 ⁵ / ₈	15	2 ¹ / ₂	3 ³ / ₄

* Rod take-out = (factor) - (0.75 x TT), for lever in high position.

Load (lbs)	14,376 18,300	18,301 24,700	24,701 31,000	31,001 39,000	39,001 48,000	48,001 58,000	58,001 69,000	69,001 87,500
J & K-Rods	2	2 ¹ / ₄	2 ¹ / ₂	2 ³ / ₄	3	3 ¹ / ₄ *	3 ¹ / ₂ *	3 ³ / ₄ *
K-Hole	2 ³ / ₈	2 ⁵ / ₈	2 ⁷ / ₈	3 ¹ / ₈	3 ³ / ₈	3 ⁵ / ₈	3 ⁷ / ₈	4 ¹ / ₈
R	3	3	4	4	4	4 ¹ / ₂	4 ¹ / ₂	4 ¹ / ₂
S	2 ⁷ / ₈	3 ¹ / ₈	3 ³ / ₈	3 ⁵ / ₈	3 ⁷ / ₈	4 ¹ / ₈	4 ³ / ₈	4 ⁵ / ₈
T (Type B)			1	1	1	1	1 ¹ / ₂	1 ³ / ₄
T (Type C)							1 ¹ / ₄	1 ¹ / ₄
W	6	6	8	8	8	9	9	9

*3³/₄ and larger is furnished with 4 UNC series thread.

Straps
 Pipe Supports
 Trapeze
 Pipe Shields & Saddles
 Pipe Roll
 Pipe Guides & Slides
 Spring Hangers
Constant Supports
 Vibration Control & Sway Brace
 Sway Strut Assembly
 Snubbers
 Special Design Products
 Application Examples
 Master Format 3 Part Specs.
 Technical Data
 Index

CONSTANT SUPPORTS

Fig. 80-V and 81-H

Weight Chart (approx) lbs, each

Hanger Sizes	Fig 80-V			Fig 81-H			
	Types A, B, C, D & E		Type G ■	Types A, B, C, D & E		Type F	
	Net	Shipping	Net	Net	Shipping	Net	Shipping
1 to 3	–	–	–	18	20	–	–
4 to 6	–	–	–	21	23	–	–
7 to 9	–	–	–	23	25	–	–
10 to 12	62	67	160	52	57	174	179
13 to 15	65	70	166	55	60	177	182
16 to 18	70	75	176	60	65	182	187
19 to 20	163	171	371	150	158	415	423
21 to 23	165	173	375	152	160	417	425
24 to 26	172	180	389	159	167	424	432
27 to 29	180	188	405	167	175	432	440
30 to 32	187	195	419	174	182	439	447
33 to 34	195	203	435	182	190	447	455
35 to 37	300	312	676	280	292	640	652
38 to 40	315	327	706	295	307	655	667
41 to 43	332	344	740	312	324	672	684
44 to 46	343	355	762	323	335	683	695
47 to 49	360	372	796	340	352	700	712
50 to 51	601	661	1,278	511	571	1,181	1,241
52 to 54	626	686	1,328	536	596	1,206	1,266
55 to 57	665	725	1,406	575	635	1,245	1,305
58 to 60	706	766	1,488	616	676	1,286	1,346
61 to 63	745	805	1,566	655	715	1,325	1,385
64 to 65	1,468	1,568	–	1,225	1,325	–	–
66 to 68	1,568	1,668	–	1,325	1,425	–	–
69 to 71	1,653	1,753	–	1,410	1,510	–	–
72 to 74	1,753	1,853	–	1,520	1,620	–	–
75 to 77	2,360	2,460	–	1,970	2,070	–	–
78 to 80	2,430	2,530	–	2,020	2,120	–	–
81 to 83	2,570	2,670	–	2,180	2,280	–	–
84 to 85	2,725	2,845	–	2,310	2,430	–	–
86 to 88	2,870	2,990	–	2,455	2,575	–	–
89 to 90	3,070	3,190	–	2,655	2,775	–	–
91 to 92	3,155	3,275	–	2,740	2,860	–	–
93 to 94	3,255	3,375	–	2,840	2,960	–	–
95 to 98	4,350	4,500	–	3,925	4,075	–	–
99 to 102	4,675	4,825	–	4,250	4,400	–	–
103 to 106	5,300	5,450	–	4,875	5,025	–	–
107 to 110	5,800	5,950	–	5,350	5,500	–	–

■ Based on 3'-0" C - C rod dimension and 8" total travel

Constant Support

Check List for Requesting a Quote or Ordering

Page ___ of ___



Anvil International
Precision Park
160 Frenchtown Rd.
North Kingstown, RI 02852

For technical information regarding
Constant Supports Call or Fax:
Fax Number: (401) 886-3056
Phone Number: (401) 886-3025

Finish: Standard Primer: _____ Galvanized: _____ Special Coating: _____

Quantity: _____

Figure No.: Options are: 80-V, 81-H
or: C-80-V, C-81-H

Size: Options are: #1 through #110 (*Size #1 through #9 available in 81-H only*) _____

Type: Options are: A through G* (*Type F Upthrust available in 81-H only, Type G available in 80-V only*) _____

Actual Travel (AT): _____ (inches)

Total Travel (TT):** _____ (inches)

Direction of Travel: _____ + (up) or - (down)

Load: _____ (lbs)

“J” Dimension (rod diameter): _____ (inches) (Not required for Type F)

Mark Number: _____ (If required)

Travel Stops: Are always Included

Lifting Lugs: Yes: _____ No: _____
Available on sizes 10 and larger.

Notes:

* *Type G Constants must also include the C-to-C dimension & the load per spring.*

** *Total Travel = Actual travel + 1” or 20% whichever is greater rounded up to the next one half inch increment.*



HORIZONTAL TRAVELER

Fig. 170

Horizontal Traveler

Size Range: Available in four sizes to take loads to 20,700 (lbs). All sizes provide for 12" of horizontal travel.

Approvals: Complies with ANSI/MSS SP-69 and MSS SP-58 (Type 58).

Features:

- Highly economical
- Minimum friction
- Virtually dust proof
- Compact – designed for minimum head room
- Versatile

Installation: Shipped ready for installation. Attach to the supporting steel by welding around the frame.

Ordering: Specify size number, figure number, name and "H" dimension, if required. Horizontal travelers will be designed for special loads, travels or dual directional travel upon request.

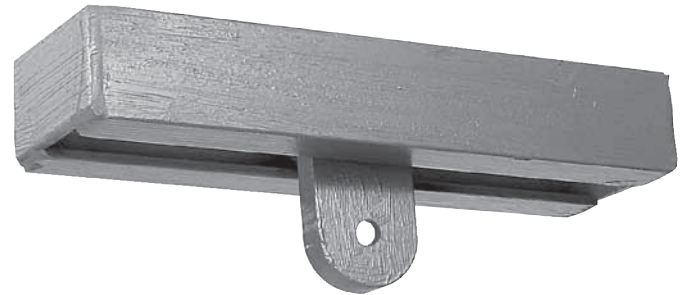

The Anvil Fig. 170 horizontal traveler facilitates the supporting of piping systems subject to linear horizontal movements where head room is limited. Designed for use with Anvil Variable Spring Hangers or Constant Supports it can also be used in conjunction with a rigid type hanger assembly. Refer to Fig. 71SD and 72SD for additional horizontal traveler designs.

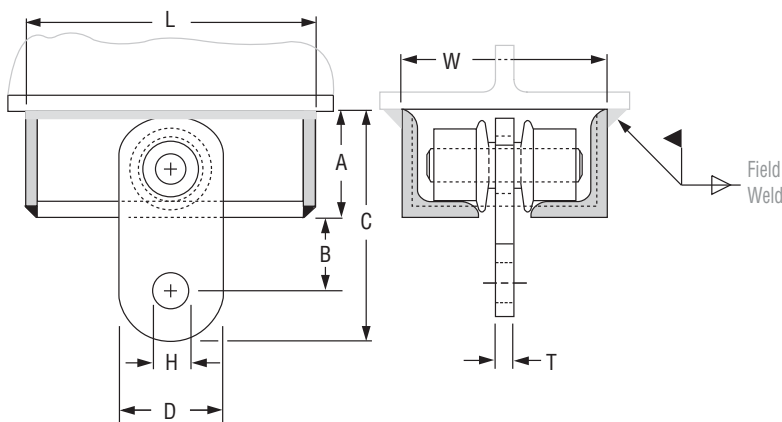

FIG. 170: LOADS (LBS) • WEIGHTS (LBS) • DIMENSIONS (IN)

Size	Maximum Load	Weight	A	B	C	D	H Max	L	T	W
1	3,770	15	2½	1⅝	5⅜	2½	1⅝	15⅝	¾	4⅝
2	6,230	37	3½	2⅝	7⅞	3½	1⅝	16⅝		6⅞
3	11,630	69	5	3	10½	5	1¾	17⅞	1	8⅞
4	20,700	102	6	3½	12½	6	2⅝	19⅞	1½	9⅞

Fig. 296

Fig. 301: with Adjustable Preload

Fig. C-296, Fig. C-301: Corrosion Resistant

Size Range: Preloads from 50 to 1,800 pounds and maximum forces from 200 to 7,200 pounds.

Finish: Standard finish: painted with semi gloss primer. Corrosion resistant: galvanized with coated coil.

Service: Recommended for controlling vibration; absorbing shock loading; guiding or restraining the movement of pipe resulting from thermal expansion; bracing a pipe line against sway.

Approvals: Complies with Federal Specification A-A-1192A (Type 55) WW-H-171E (Type 55), ANSI/MSS SP-69 and MSS SP-58 (Type 50).

Installation: Shipped ready for installation (see line cuts of Fig. 297, Fig. 298, Fig. 302 and Fig. 303 on page 187 for typical installed hanger assemblies).

Adjustment: The sway brace should be in the neutral position when the system is hot and operating, at which time both spring plates should be in contact with the end plates. If they are not, the sway brace should be adjusted to the neutral position by use of the load coupling.

Features:

- Vibration is dampened with an instantaneous opposing force bringing the pipe back to normal position.
- A single pre-loaded spring provides two way movement.
- One spring saves space and simplifies design.
- Spring has 3-inch travel in either direction.
- Accurate neutral adjustment assured.
- A tight fitting connection at rear bracket and clamp.

Additional Features – Fig. 301:

The Fig. 301 sway brace is adjustable from the initial preload to the maximum capacity of the unit selected. It is equipped with a load-deflection scale to facilitate preload adjustment. Preload adjustment reduces spring travel accordingly.

Ordering: Specify figure, name and sway brace size. The Anvil Fig. 296 and Fig. 301 consist of the sway brace only. Available corrosion resistant as Fig. C-296 and Fig. C-301.

Preload adjustment – Fig. 301: Turn the preload adjustment nut until desired preload is indicated. Turn thrust nut until it is in contact with the spring plate. Lock in position. Indicated deflection must be greater than thermal movement.

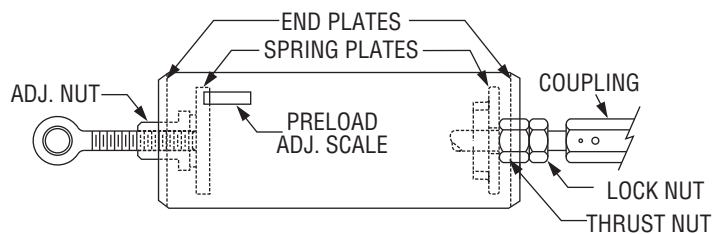

- Straps
- Pipe Supports
- Trapeze
- Pipe Shields & Saddles
- Pipe Roll
- Pipe Guides & Slides
- Spring Hangers
- Constant Supports
- Vibration Control & Sway Brace**
- Sway Strut Assembly
- Snubbers
- Special Design Products
- Application Examples
- Master Format 3 Part Specs.
- Technical Data
- Index

Fig. 296, Fig. 301: with Adjustable Preload

Sway Brace (cont.)

Fig. C-296, Fig. C-301: Corrosion Resistant

Size selection: The Anvil Vibration Control and Sway Brace gives full deflection forces from 200 to 7,200 pounds and has initial precompressed spring forces from 50 to 1,800 pounds to control vibrations and pipe sway. The amount of force needed to control piping should be in proportion to the mass, amplitude of movement, and nature of disturbing forces acting on the pipe. When it is possible to calculate the exact restraining force required, the size of the Vibration Control and Sway Brace capable of providing this force should be selected. As a general reference, the following sizes have been historically used for the pipe sizes shown:

- #1 - 3 1/2" and smaller
- #2 - 4" to 8"
- #3 - 10" to 16"
- #4 - 18" to 24"
- #5 and #6 - above 24"

Installation: 1) attach rear bracket to structure and pipe attachment to piping or equipment. 2) connect coupling to pipe attachment and turn coupling so that spring is compressed in direction opposite to and by approximate amount of piping thermal movement.

Important: Final adjustment should be made with the pipe in its hot or operating position. Turn the coupling until both spring plates are in contact with the end plates of the Sway Brace. When correct tension adjustments are completed, the brace exerts no force on the pipe in its operating position. Under shutdown conditions, the brace allows the pipe to assume its cold position. It exerts a nominal cold strain force equal to the preload force plus the amount of travel from the hot to cold position, times the spring scale of the particular size of the Vibration Control and Sway Brace.

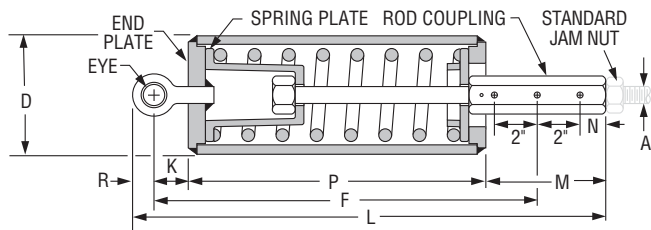

Fig. 296

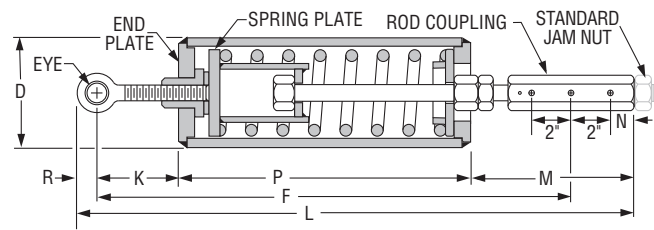

Fig. 301

FIG. 296: LOADS • WEIGHTS (LBS) • DIMENSIONS (IN)

Sway Brace Size	Pipe Size	Preload and Spring Scale (lb/in)	Max Force (lbs)	Weight	Rod Size Fig. 297 A	Eye		D	Length F	K	L	M	N	P	R
						Dia. Hole	Thickness								
1	1 1/2 to 24	50	200	22	3/4	1	1	4 1/2	13 5/8	1 5/8	17 7/8	6 1/8	1	8 7/8	1 1/4
2		150	600	25	1				14 3/8		18 3/8			9 5/8	
3		450	1,800	36	1				17 3/4		22			13	
4		900	3,600	64	1 1/4				17		22 5/16			11 1/2	
5	6 to 30	1,350	5,400	79	1 1/2	1 1/2	6 5/8	18 1/2	2 1/4	23 13/16	6 3/4	1 1/2	13	1 13/16	
6		1,800	7,200	95				1 1/2					20 1/2		25 13/16

FIG. 301: LOADS • WEIGHTS (LBS) • DIMENSIONS (IN)

Sway Brace Size	Pipe Size	Preload and Spring Scale (lb/in)	Max Force (lbs)	Weight	Rod Size Fig. 302 A	Eye		D	Length F	K	L	M	N	P	R
						Dia. Hole	Thickness								
1	1 1/2 to 24	50	200	23	3/4	1	3/4	4 1/2	20	5 15/16	24 1/4	7 7/8	1	9 3/16	1 1/4
2		150	600	26	1				20 3/4		25			9 9/16	
3		450	1,800	38	1				24 1/8		28 3/8			13 5/16	
4		900	3,600	67	1 1/4				24 5/16		29 5/8			12	
5	6 to 30	1,350	5,400	82	1 1/2	1 1/2	6 5/8	25 13/16	6 9/16	31 1/8	9 1/4	1 1/2	13 1/2	1 13/16	
6		1,800	7,200	98				1 1/2					27 13/16		33 1/8

Fig. 297 and Fig. 298 Fig. 302 and Fig. 303: with Adjustable Preload Fig. C-297, Fig. C-298, Fig. C-302 and Fig. C-303: Corrosion Resistant

Sway Brace Assembly

The Fig. 297 and Fig. 302 consist of a structural attachment, two studs, the Sway Brace, extension piece up to 2' 0" in length as required, and a modified Fig. 295 pipe clamp.

The Fig. 298 and Fig. 303 consist of a structural attachment, two studs, the Sway Brace, adjustable extension piece 2' 1" in length or over as required, an adapter and a tolerated pipe clamp.

Note: In specifying Sway Brace assemblies where the "W" dimension exceeds 2' 0" in length, the Fig. 298 or Fig. 303 assembly is required. Verify that calculated "W" is within the min/max shown in table.

Ordering assemblies: Specify figure number, name, Sway Brace size, pipe size, "W" dimension. Available corrosion resistant as Fig. C-297, C-298, C-302 and C-303.

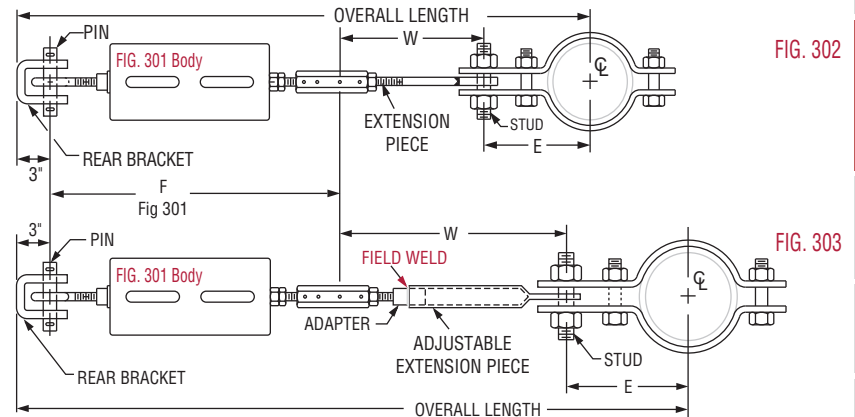
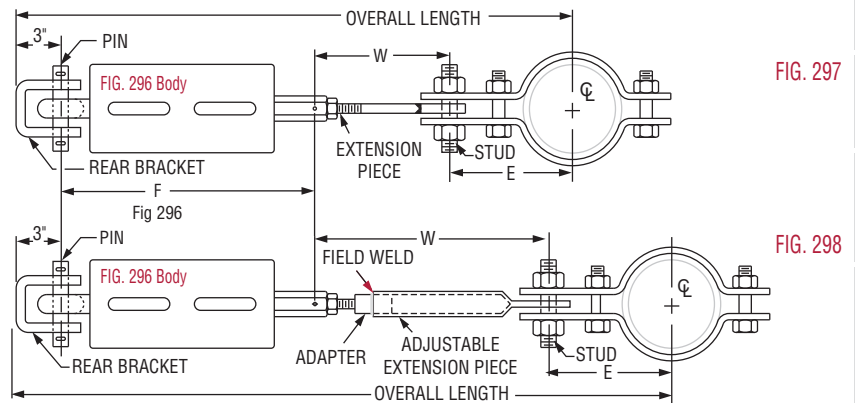

FIG. 297, 298, 302, 303, C-297, C-298, C-302 AND C-303: DIMENSIONS (IN)

Pipe Size	E		
	Size 1 - 4 Carbon	Size 5 & 6 Carbon	Size 5 & 6 Alloy
1½	4⅞	—	—
2	5⅞	—	—
2½	5¾	—	—
3	5 ¹⁵ / ₁₆	—	—
3½	6 ³ / ₁₆	—	—
4	6½	—	—
5	7	—	—
6	8 ⁸ / ₁₆	11 ⁷ / ₁₆	12 ¹ / ₁₆
8	9 ⁹ / ₁₆	12 ⁷ / ₁₆	13 ³ / ₁₆
10	10 ⁵ / ₈	13½	14 ³ / ₈
12	11 ⁵ / ₈	14¾	15 ³ / ₈
14	12 ¹¹ / ₁₆	15¾	16
16	13 ¹¹ / ₁₆	16¾	17
18	14 ¹¹ / ₁₆	17¾	18
20	15 ⁵ / ₈	19	19½
24	17 ⁵ / ₈	21 ⁵ / ₈	22 ¹ / ₈
30	—	25 ¹ / ₈	25 ⁵ / ₈
	—		

FIG. 297, 298, 302, 303, C-297, C-298, C-302 AND C-303: DIMENSIONS (IN)

Sway Brace Size	W			
	Fig. 297, 302		Fig. 298, 303	
	Min	Max	Min	Max
1	7 ¹⁵ / ₁₆	24	24	90 ³ / ₁₆
2	8 ⁹ / ₁₆	24	24	86 ¹¹ / ₁₆
3	8 ⁹ / ₁₆	24	24	79 ⁹ / ₁₆
4	9 ¹¹ / ₁₆	24	24	74 ¹³ / ₁₆
5	9 ¹³ / ₁₆	24	24 ⁷ / ₈	61 ¹³ / ₁₆
6				46 ¹³ / ₁₆

SWAY STRUT ASSEMBLY

Fig. 211, Fig. C-211

Fig. 640, Fig. C-640: Field Welded Strut

Sway Strut Assembly

Finish: Painted (Fig. 211 & Fig. 640)
or Galvanized (Fig. C-211 & C-640)

Service: Used to restrain movement of piping while allowing for movement in the other two directions.

How to size:

- (1) Select size consistent with max. load to be restrained.
- (2) C to C is obtained by subtracting E and A from the distance from structural steel to center of pipe. Verify that the calculated C to C is within the min/max limits.
- (3) Determine W dimension by: $W=(C \text{ to } C)-2F$.

Installation: Shipped assembled. Securely fasten bracket to structure, make necessary adjustment in overall length, and fasten clamp to pipe.

Features:

- Effective under either tensile or compressive force.
- Provides 3 1/2" (Fig. 211) or 2" (Fig. 640) of field adjustment in either direction.
- Self-aligning bushings permits $\pm 5^\circ$ misalignment or angular motion. Bushings are coated with a dry lubricant.

Ordering: Specify figure number, assembly size, name, option number, normal pipe size or special O.D., and "W" dimension. Alloy pipe clamps are available as a special order. For restraint parallel to the pipe axis using two sway strut assemblies, a riser clamp is available. If a riser clamp is required, consult the nearest Anvil representative for information about this clamp.

Note: The rear bracket assembly can be ordered separately.

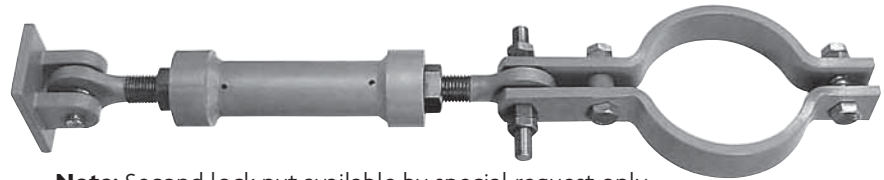

Note: Second lock nut available by special request only.

E-TAKE OUT: DIMENSIONS (IN)										
Pipe Size	Size A	Size B & C	Size 1 & 2	Size 3	Size 4	Size 5	Size 6	Size 7	Size 8	
3/4	2 ⁷ / ₁₆	—	—	—	—	—	—	—	—	
1	2 ⁹ / ₁₆	—	—	—	—	—	—	—	—	
1 1/4	2 ¹¹ / ₁₆	—	—	—	—	—	—	—	—	
1 1/2	4 ¹ / ₈	—	—	—	—	—	—	—	—	
2	5 ¹ / ₈	6 ³ / ₈	6 ³ / ₈	—	—	—	—	—	—	
2 1/2	5 ³ / ₈	7	7	8 ¹ / ₈	—	—	—	—	—	
3	5 ¹⁵ / ₁₆				—	—	—	—	—	—
3 1/2	6 ³ / ₁₆				—	—	—	—	—	—
4	6 ¹ / ₂	7 ¹ / ₄	7 ¹ / ₄	8 ³ / ₈	—	10	—	—	—	
5	7 ³ / ₄	7 ³ / ₄	7 ³ / ₄	9 ¹ / ₈	9 ¹ / ₈		—	—	—	—
6	8 ³ / ₈	8 ³ / ₈	8 ³ / ₈	10	10		—	11 ¹ / ₈	—	—
8	9 ³ / ₈	9 ³ / ₈	9 ³ / ₈	11 ¹ / ₄	11 ¹ / ₄	11 ¹ / ₄	12 ⁵ / ₈	—	—	
10	10 ¹ / ₂	10 ¹ / ₂	10 ¹ / ₂	12 ³ / ₄	12 ³ / ₄	12 ³ / ₄	14 ¹ / ₄	14 ¹ / ₄	16 ¹ / ₄	
12	—	11 ¹ / ₈	11 ¹ / ₈	13 ³ / ₈	13 ³ / ₈	13 ³ / ₈	15 ³ / ₈	15 ³ / ₈	17 ¹ / ₄	
14	—	12 ³ / ₈	12 ³ / ₈	14 ¹ / ₂	14 ¹ / ₂	14 ¹ / ₂	16	16 ¹ / ₄	18	
16	—	13 ³ / ₈	13 ³ / ₈	15 ¹ / ₄	15 ¹ / ₄	15 ¹ / ₄	17 ¹ / ₈	17 ¹ / ₂	19	
18	—	14 ³ / ₈	14 ³ / ₈	16 ³ / ₈	16 ³ / ₈	16 ³ / ₈	18 ¹ / ₄	18 ¹ / ₂	20 ¹ / ₄	
20	—	15 ³ / ₄	15 ³ / ₄	17 ³ / ₄	17 ³ / ₄	17 ³ / ₄	19 ¹ / ₄	19 ³ / ₄	21 ¹ / ₂	
24	—	18 ¹ / ₈	18 ¹ / ₈	19 ⁷ / ₈	19 ⁷ / ₈	19 ⁷ / ₈	21 ³ / ₄	21 ³ / ₄	24	
30	—	21 ¹ / ₄	21 ¹ / ₄	23	23	23	25	25	28	
36	—	24	24	26 ¹ / ₂	26 ¹ / ₂	26 ¹ / ₂	28 ¹ / ₈	28 ¹ / ₈	31 ¹ / ₄	

Note: "E" Dimensions are for carbon steel clamps only, with maximum insulation of 4" and temperature of 650°.

Fig. 211, Fig. C-211
Fig. 640, Fig. C-640: Field Welded Strut

Sway Strut Assembly

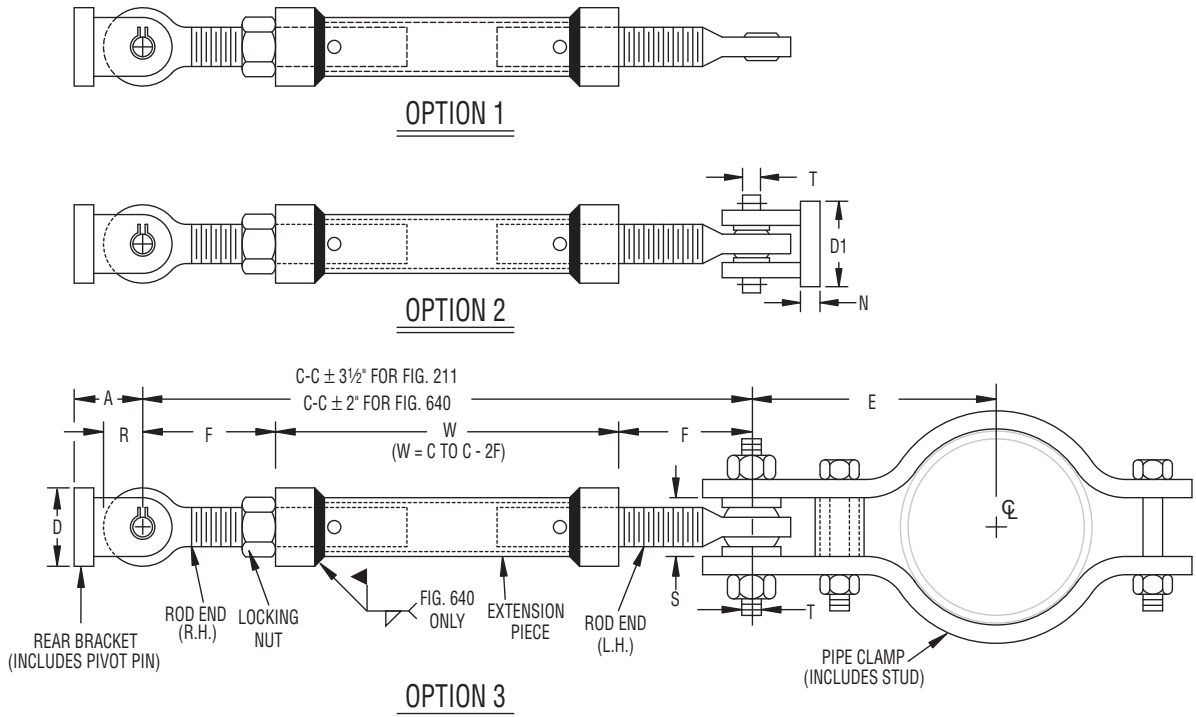

FIG. 211, C-211, FIG. 640 & FIG. C-640: LOAD (LBS) • DIMENSIONS (IN)

Size	Fig. 211 & Fig. 640										Fig. 211					Fig. 640			
	Load ■	Rod End	Ext. Piece	A	D	D1	N	R	S	T	C-C		W		F	Weld Z	C-C		F
											Max	Min	Max	Min			Max	Min	
A	650	3/4	1	1	2	1 1/4	1/4	5/8	5/8	0.374 0.372	60	16 1/2	53 3/8	9 3/8	3 7/16	3/16	60	12 1/8	2 11/16
B	1,500	1	1 1/2	2 1/2		2 3/8	5/8	1 3/8	1 3/8	0.749 0.747	108	19	99 3/8	10 3/8	4 7/16		96	14 7/16	3 11/16
C	4,500	1	2		3	2 7/8	3/4	1 1/2		0.749 0.747	120	21	110 3/8	110	11 3/8	4 7/8		5/16	16 1/2
1	8,000	1 1/4	2 1/2	3		3	3 3/16	3/4	2	1 11/16		0.999 0.997	21 3/8		110	11 3/8	5		3/8
2	11,630	1 1/2			3						3	3 3/16	3/4	2	1 11/16	1.249 1.247	22 7/8	108 1/2	
3	15,700	1 3/4	3	3		3 3/16	3/4	2	1 11/16	1.249 1.247						25	108	108	6
4	20,700	2			3					3	3 3/16	3/4	2	1 11/16	1.499 1.497	26 1/2	106 1/2		
5	27,200	2 1/4	3	3		3 3/16	3/4	2	1 11/16						1.749 1.747	28 1/4	104 3/4	108	7 5/8
6	33,500	2 1/2			3					3	3 3/16	3/4	2	1 11/16	1.999 1.997	32 1/2	102 1/2		
7	68,200	3	3	3		3 3/16	3/4	2	1 11/16						2.499 2.497	39 1/4	98	108	17 1/4
8	120,000	4			3					3	3 3/16	3/4	2	1 11/16	2.499 2.497	39 1/4	98		

■ Loads must not be applied outside a 10° included angle cone of action to the pipe clamp axis without special authorization.
 Fig. 640 shipped at maximum length C-C, field cut to "W" to suit, unless otherwise specified.

Fig. 222, C-222

Mini-Sway Strut Assembly

Finish: Painted or Galvanized

Service: Used to restrain movement of piping in one direction while allowing movement in the other two directions.

How to size:

- (1) Select size consistent with max. load to be restrained.
- (2) C to C is obtained by subtracting E and A from the distance from structural steel to center of pipe. Verify that the calculated C to C is within the min/max limits.

Installation: Shipped assembled. Securely fasten bracket to structure, make necessary adjustment in overall length, and fasten clamp to pipe.

Features:

- Assembly provides a shorter C to C dimension.
- Effective under either tensile or compressive force.
- Self-aligning bushings permit ± 5 misalignment or angular motion. Bushings are coated with a dry lubricant.

Ordering: Specify assembly size, figure number, name, finish, pipe O.D. or option number, if other than standard, and load. Ex: Size A-1, Fig. 222 mini sway strut 10 ³/₄ O.D. pipe, 650#. Alloy pipe clamps are available as a special order. For restraint parallel to the pipe axis using two sway strut assemblies, a riser clamp is available. Contact your Anvil representative for information about this clamp.

Note: The rear bracket assembly can be ordered separately

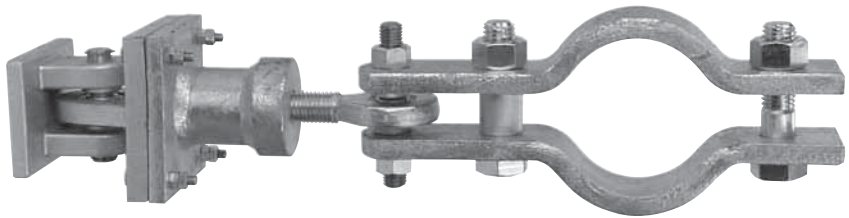

E-TAKE OUT: DIMENSIONS (IN)			
Pipe Size	Size A	Size B & C	Size 1
3/4	2 ⁷ / ₁₆	—	—
1	2 ⁹ / ₁₆	—	—
1 1/4	2 ¹¹ / ₁₆	—	—
1 1/2	4 ¹ / ₈	—	—
2	5 ¹ / ₈	6 ³ / ₈	6 ³ / ₈
2 1/2	5 ³ / ₈	7	7
3	5 ¹⁵ / ₁₆		
3 1/2	6 ³ / ₁₆		
4	6 ¹ / ₂	7 ¹ / ₄	7 ¹ / ₄
5	7 ³ / ₄	7 ³ / ₄	7 ³ / ₄
6	8 ³ / ₈	8 ³ / ₈	8 ³ / ₈
8	9 ³ / ₈	9 ³ / ₈	9 ³ / ₈
10	10 ¹ / ₂	10 ¹ / ₂	10 ¹ / ₂
12	—	11 ⁷ / ₈	11 ⁷ / ₈
14	—	12 ⁵ / ₈	12 ⁵ / ₈
16	—	13 ⁵ / ₈	13 ⁵ / ₈
18	—	14 ⁵ / ₈	14 ⁵ / ₈
20	—	15 ³ / ₄	15 ³ / ₄
24	—	18 ¹ / ₈	18 ¹ / ₈
30	—	21 ¹ / ₄	21 ¹ / ₄
36	—	24	24

Note: "E" Dimensions are for carbon steel clamps only, with maximum insulation of 4" and temperature of 650°.

Fig. 222, C-222

Mini-Sway Strut Assembly (cont.)

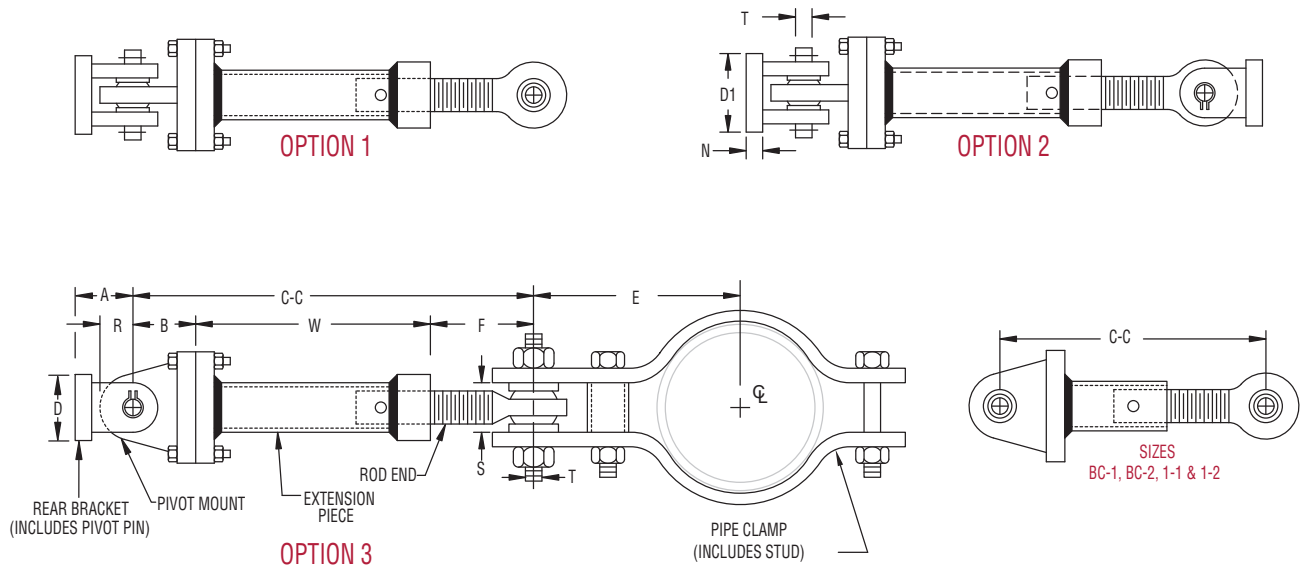

FIG. 222, C-222: LOADS (LBS) • DIMENSIONS (IN)

Assembly Size	Load	C-C		F		W	Rod End	A	D	D1	N	R	S	T Nom.	B		
		Max	Min	Max	Min												
A	A-1	650	6 ⁵ / ₁₆	5 ⁵ / ₁₆	2 ¹³ / ₁₆	1 ¹ / ₁₆	2 ⁵ / ₈	3/4	1	2	1 ¹ / ₄	1/4	5/8	5/8	3/8	1 ³ / ₁₆	
	A-2		8 ¹ / ₂	6 ¹ / ₂	4 ¹ / ₄	2 ¹ / ₄											3 ¹ / ₁₆
	A-3		13 ³ / ₄	8 ¹ / ₂	6 ¹ / ₄	1 ¹ / ₂											5 ¹³ / ₁₆
B & C	BC-1	4,500	6 ¹ / ₂	6	2 ⁷ / ₈	2 ³ / ₈	1 ¹ / ₂	1	2 ¹ / ₂	2	2 ³ / ₈	5/8	1 ³ / ₈	1 ¹ / ₈	3/4	2 ¹ / ₈	
	BC-2		7 ³ / ₄	6 ⁵ / ₈	3 ¹ / ₂	2 ³ / ₈											2 ¹ / ₈
	BC-3		8 ¹¹ / ₁₆	7 ⁹ / ₁₆	3 ¹³ / ₁₆	2 ¹¹ / ₁₆											2 ³ / ₄
	BC-4		10 ¹⁵ / ₁₆	8 ¹ / ₁₆	4 ¹⁵ / ₁₆	2 ¹¹ / ₁₆											3 ⁷ / ₈
	BC-5		15 ⁷ / ₁₆	10 ¹⁵ / ₁₆	7 ³ / ₁₆	2 ¹¹ / ₁₆											6 ¹ / ₈
	BC-6		19 ⁹ / ₁₆	15 ⁷ / ₁₆	9 ¹ / ₄	5 ¹ / ₈											8 ³ / ₁₆
1	1-1	8,000	8 ⁷ / ₈	8	3 ¹ / ₁₆	2 ¹³ / ₁₆	2 ¹⁵ / ₁₆	1 ¹ / ₄	2 ¹ / ₂	2	2 ⁷ / ₈	3/4	1 ¹ / ₁₆	1 ³ / ₈	1	2 ¹ / ₄	
	1-2		10 ⁵ / ₈	8 ⁷ / ₈	4 ⁹ / ₁₆	2 ¹³ / ₁₆											3 ¹³ / ₁₆
	1-3		11 ⁷ / ₈	10 ¹ / ₄	4 ¹³ / ₁₆	3 ³ / ₁₆											4 ¹³ / ₁₆
	1-4		15 ¹ / ₈	11 ⁷ / ₈	6 ⁷ / ₁₆	3 ³ / ₁₆											6 ⁷ / ₁₆
	1-5		21 ⁵ / ₈	15 ¹ / ₈	9 ¹ / ₁₆	3 ³ / ₁₆											9 ¹ / ₁₆

■ Loads must not be applied outside a 10° included angle cone of action to the pipe clamp axis without special authorization.

Fig. 3306

Fig. 3307: with Extension Piece

Hydraulic Snubber

Size Range: Seven standard sizes with load ratings from 350 to 120,000 pounds.

Finish: Basic unit is corrosion resistant salt bath nitrided. Attachments are painted with semi gloss primer, carbon zinc or other.

Service: For use on piping systems or equipment when unrestrained thermal movement must be allowed, but which must be restrained during impulsive or cyclic disturbance. The unit is not effective against low amplitude, high frequency movement. Use with standard settings to prevent destructive response to earthquakes, flow transients or wind load. Special settings are available to absorb the continuous thrust resulting from safety valve blow-off or pipe rupture.

Standard Settings: The standard settings are:

Locking (activation) velocity 8 ± 2 in./min. Bleed rate (post activation) at normal rated load 4 ± 1 in./min. (Special settings are available). The valves are calibrated at the factory within the tolerances indicated at room temperature. Locking velocity and bleed rate will vary with temperature. Testing has indicated that there is little effect of these changes on dynamic operation.

Features:

- Temperature compensating valves minimize the effects of temperature on lockup and bleed.
- Pressurized reservoirs
- Continuous operation at 150° F with brief transients to 350° F
- Factory calibrated valves
- Rapid, positive valve closure
- Special design minimizes the “lost motion” which results from the shifting and seating of piston seals
- Unlocked resisting force is less than 17 1/2 pounds for sizes 1/4 and 1/2 and less than 2% of rated load for larger sizes
- Stable non-flammable, long life hydraulic fluid
- Self-aligning bushings permit $\pm 5^\circ$ misalignment or angular motion. Bushings are coated with a dry lubricant.
- Choice of coating (paint, primer, carbo zinc, epoxy, plating or other) for attachments.

Applications:

- Direct replacement for Fig. 306/307 Pacific Scientific (PSA) mechanical snubbers: Exact load ratings, exact pin sizes, exact stroke lengths and exact pin-to-pin dimensions. The cross sectional dimensions of the Fig. 3306 are based on those of PSA to facilitate non-interference one-to-one replacement. Pins, clamps, pivot mounts, extension pieces, and rear brackets used with PSA snubbers are compatible with the Fig. 3306 and can be utilized.
- New installations: For new installations, the Fig. 3306 is available with a complete line of pipe clamps and rear brackets.



Fig. 3306



Fig. 3307 with Extension Piece

LOADS (LBS)		
Size	Stroke (in)	Max Load *
1/4	4	350
1/2	2 1/2	650
1	4, 8	1,500
3	5, 10	6,000
10	6, 12	15,000
35	6	50,000
100	6	120,000

* Loads must not be applied outside a 10° included angle cone of action to the pipe clamp axis without special authorization.

Fig. 3306 Fig. 3307: with Extension Piece

Hydraulic Snubber

How to size:

- Size:** Use table on the previous page to select size large enough to restrain expected load.
- Stroke:** Define expected movement of the pivot joining the snubber with the equipment to be protected (cold to hot plus any abnormal movements). Determine maximum and minimum distances between this curve and the fixed pivot pin of the snubber. The minimum recommended stroke is 20% greater than the difference between these lengths. Make sure that all normal movement of equipment will be accommodated without the snubber entering the last $\frac{1}{4}$ " (preferably $\frac{1}{2}$ ") of the stroke at either end.
Note: If erected position at the snubber's location on the equipment is outside of the range of normal cold-to-hot movement (e.g cold pull of pipe), the snubber should not be installed until after the equipment is in its cold position. This eliminates the need of providing for the extra travel in the snubber's stroke.
- Piston position:** To aid in measuring the piston position, we have shown a dimension, "Z". This dimension represents the distance between the cylinder head and the end of the rod when the rod is fully retracted. Whenever specifying the position at which the piston rod is to be set, the total dimension from the cylinder head to the end of the rod should be given. Thus, *piston setting = piston position + Z*.
- Assembly length:** Determine the installed "C" dimension by adding the installed piston position (not setting) to C minimum. Lay in takeout dimensions E and/or B, and find required pin-to-pin snubber length. If a pin-to-pin length adjustment is desired, use Fig. 3307. Calculate the required "W" dimension by subtracting (C installed + F) from the required pin-to-pin length. If this is less than W minimum, only a Fig. 3306 can be used, and one of the attachments will have to be moved or shimmed to suit. If a Fig. 3306 is to be used, make sure that the required pin-to-pin length is at least as great as (C installed + B). If neither a Fig. 3306 nor a Fig. 3307 can be accommodated, and the installation cannot be modified, consult your Anvil representative about designing a special or modified unit.
- Installed piston setting:** As indicated previously, the snubber should be installed at its cold piston position if possible. From the installed position, take extension (outward movement) of the piston rod as positive (+) and retraction as negative (-).
Installed piston position =

$$\left(\frac{\text{Stroke} - (\text{Algebraic Sum of Movements})}{2} \right)$$

Ordering: Specify

- Fig. No.
- Size
- Stroke
- Load
- Cold and hot piston settings
- W dimension when specifying Fig. 3307
- Pipe clamp size when specifying option 3
- Attachment surface coating
- Option

FIG. 3306 & 3307 OPTIONS

Option	Consists of...
0	Fig 3306: Basic unit (snubber) with pivot mount and one rear bracket. Fig. 3307: Basic unit with extension piece and one rear bracket.
1	Option 0 plus cylinder eye.
2	Option 0 plus cylinder eye and additional rear bracket.
3	Option 0 plus cylinder eye and pipe clamp.



Fig. 3306

Hydraulic Shock and Sway Suppressor (cont.)

Fig. 3307: with Extension Piece

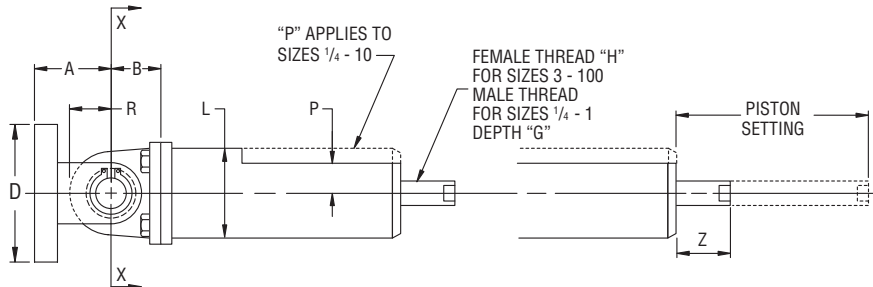

FIG. 3306 (OPTION 0)

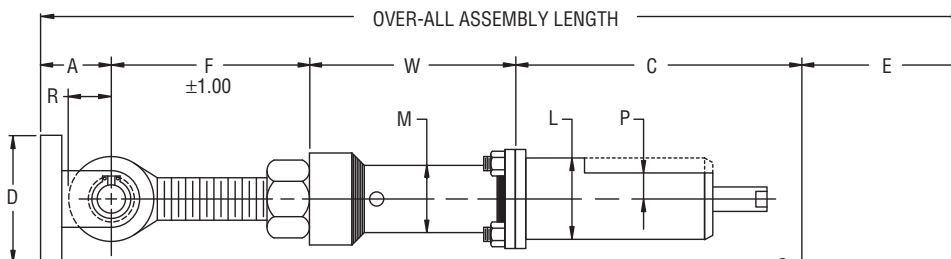
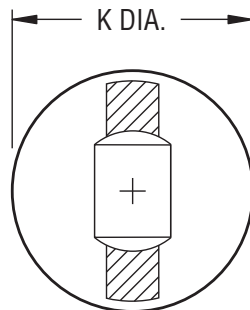
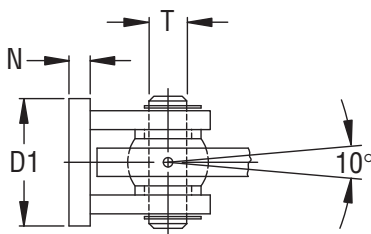

FIG. 3307 (OPTION 0)



BOLT PLATE (SIZES 1/4 - 10)
SECTION X-X

NOTE: CYLINDER EYE MAY BE ROTATED TO ANY POSITION

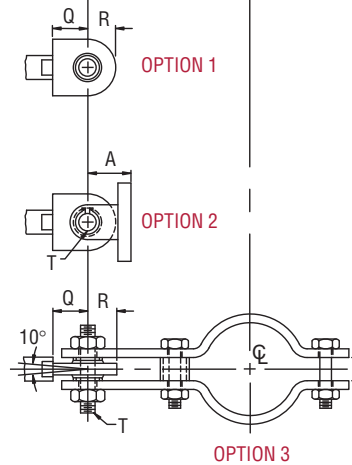

Fig. 3306

Hydraulic Snubber (cont.)

Fig. 3307: with Extension Piece

FIG 3306, 3307 DIMENSIONS (IN)																								
Snubber Size	Stroke	A	B	C *			D	D1	F	G	H	K Dia	L Dia	M Dia	N	P	Q Ref	R Max	S	T Dia	W		Max Pin to Pin	Z
				Min	Mid	Max															Min	Max		
¼	4.00	1.00	1.19	9.0	11.00	13.0	2.00	1.25	2.94	0.38	¾-16-2A	2.25	2.25	1.31	0.25	0.62	1.19	0.63	0.63	0.374 0.372	3.50	45.56	61.50	0.19
½	2.50			7.5	8.75	10.0															3.50	48.56		
1	4.00	1.62	1.56	11.0	13.00	15.0	4.00	1.75	3.00	0.38	¾-16-2A	3.25	2.38	1.31	0.38	0.69	2.00	1.00	1.00	0.499 0.497	3.87	43.50	61.50	0.19
	8.00			15.5	19.50	23.5															N/A	N/A		
3	5.00	2.12	2.62	14.0	16.50	19.0	5.00	3.62	4.50	0.75	¾-18-2B	4.62	4.62	2.38	0.50	1.44	2.12	1.38	1.38	0.749 0.747	4.44	37.50	61.00	1.25
	10.00			20.0	25.00	30.0															N/A	N/A		
10	6.00	3.00	4.06	16.1	19.10	22.1	7.00	4.00	5.12	1.00	7/8-14-2B	5.75	5.75	2.88	1.00	1.62	2.00	1.62	1.38	0.999 0.997	5.19	44.50	71.72	2.10
	12.00			23.1	29.10	35.1															N/A	N/A		
35	6.00	4.62	3.00	24.0	27.00	30.0	9.75	6.50	7.75	1.88	1 1/8-12-2B	-	6.00	4.50	1.25	-	3.00	2.79	2.00	1.499 1.497	5.25	79.75	117.50	1.48
100	6.00	7.25	3.80	29.0	32.00	35.0	14.0	8.75	8.31	3.00	3-12-2B	-	10.00	5.56	2.00	-	3.80	3.44	-	-	6.50	74.18	117.50	3.38

* Adapters are available to match existing pin-to-pins.

FIG 3306, 3307 DIMENSIONS (IN)										
*Pipe Size	E-Take Out					Clamp Stock Size				
	Snubber Size					Snubber Size				
	¼ & ½	1	3	10	35	¼ & ½	1	3	10	35
¾	2 7/16	-	-	-	-	¾ x 1	-	-	-	-
1	2 9/16	-	-	-	-	¾ x 1	-	-	-	-
1 ¼	2 11/16	-	-	-	-	¾ x 1	-	-	-	-
1 ½	4 1/8	-	-	-	-	¼ x 1 ¼	-	-	-	-
2	5 1/8	-	-	-	-	¼ x 1 ¼	-	-	-	-
2 ½	5 3/8	7	7	7	-	¼ x 1 ¼	¾ x 1 ¾	½ x 2 ½	5/8 x 2 ½	-
3	5 15/16	7	7	8 1/8	-	¼ x 1 ¼	¾ x 1 ¾	½ x 2 ½	5/8 x 2 ½	-
3 ½	6 3/16	7	7	8 1/8	-	¼ x 1 ¼	¾ x 1 ¾	½ x 2 ½	5/8 x 2 ½	-
4	6 ½	7 ¼	7 ¼	8 3/8	-	5/16 x 2	½ x 1 ½	5/8 x 2 ½	5/8 x 2 ½	-
5	7 ¼	7 ¾	7 ¾	9 1/8	-	5/16 x 2	½ x 1 ½	5/8 x 2 ½	¾ x 3	-
6	8 3/8	8 3/8	8 3/8	10	-	5/16 x 2	½ x 2	5/8 x 3	¾ x 4	-
8	9 3/8	9 3/8	9 3/8	11 ¼	12 5/8	5/16 x 2	½ x 2 ½	¾ x 3	¾ x 5	1 x 7
10	10 ½	10 ½	10 ½	12 ¾	14 ¼	5/16 x 2	5/8 x 2 ½	¾ x 4	¾ x 6	1 ¼ x 6
12	-	11 7/8	11 7/8	13 3/8	15 3/8	-	5/8 x 2 ½	¾ x 5	1 x 5	1 ¼ x 6
14	-	12 5/8	12 5/8	14 ½	16	-	5/8 x 2 ½	¾ x 5	1 x 5	1 ¼ x 7
16	-	13 5/8	13 5/8	15 ¼	17 1/8	-	5/8 x 3	¾ x 5	1 x 5	1 ¼ x 8
18	-	14 5/8	14 5/8	16 3/8	18 ¼	-	¾ x 3	¾ x 5	1 x 6	1 ¼ x 9
20	-	15 ¼	15 ¼	17 ¾	19 ¼	-	¾ x 3	¾ x 5	1 x 7	1 ½ x 8
24	-	18 1/8	18 1/8	19 7/8	21 ¾	-	¾ x 4	¾ x 5	1 x 7	1 ½ x 9
30	-	21 ¼	21 ¼	23	25	-	¾ x 4	¾ x 6	1 x 7	1 ½ x 10
36	-	24	24	26 ½	28 1/8	-	¾ x 5	¾ x 7	1 x 7	1 ½ x 10

* Intermediate sizes between 20 and 36 are available and will have the take out and stock of the next larger size.

Note: "E" Dimensions are for carbon steel clamps only, with maximum insulation of 4" and temperature of 650°.

Fig. 200, Fig. C-200 Fig. 201, Fig. C-201: with Extension Piece

Hydraulic Snubber

Size Range: Seven standard sizes with cylinder bores of 1½" to 8" and with normal load ratings from 3,000 pounds to 128,000 pounds. All are available with 5", 10", 15", or 20" strokes except the 1½" size which is offered with 5" and 10" strokes only. Snubbers are available with integral or remote reservoirs.

Finish: Fig. 200/201 painted with semi gloss primer. Fig. C-200/C-201 corrosion resistant; painted with carbo zinc.

Service: For use on piping systems or equipment when unrestrained thermal movement must be allowed, but which must be restrained during impulsive or cyclic disturbance. The unit is not effective against low amplitude, high frequency movement. Use with standard settings to prevent destructive response to earthquakes, flow transients or wind load. Special settings are available to absorb the continuous thrust resulting from safety valve blow-off or pipe rupture.

Standard settings: The standard settings are: Locking (activation) velocity 8 ±2 in/min. Bleed rate (post activation) at normal rated load 4 ±1 in/min. (Special settings are available). The valves are calibrated at the factory within the tolerances indicated at room temperature. Locking velocity and bleed rate will vary with temperature. Testing has indicated that there is little effect of these changes on dynamic operation.

Features:

- Choice of valve type
 - Adjustable – permits field adjustments
 - Temperature compensating – minimizes the effects of temperature on lockup and bleed
- Choice of reservoir type
 - Transparent – continuous operation at 200° F with brief transients to 250° F
 - Metal or pressurized metal – allows brief transients to 340° F
 - Pressurized – eliminates the concern of reservoir orientation relative to valve and cylinder – minimizes internal contamination
 - Remote
- Factory calibrated valves
- Rapid, positive valve closure
- Special design minimizes the “lost motion” which results from the shifting and seating of piston seals
- Unlocked resisting force is less than 1% of rated load
- Stable, non-flammable, long life hydraulic fluid made highly visible for ease of inspection
- Self-aligning bushings permit ± 5° misalignment or angular motion. Bushings are coated with a dry lubricant.
- Choice of coating (paint, primer, carbo zinc, epoxy, plating or other)

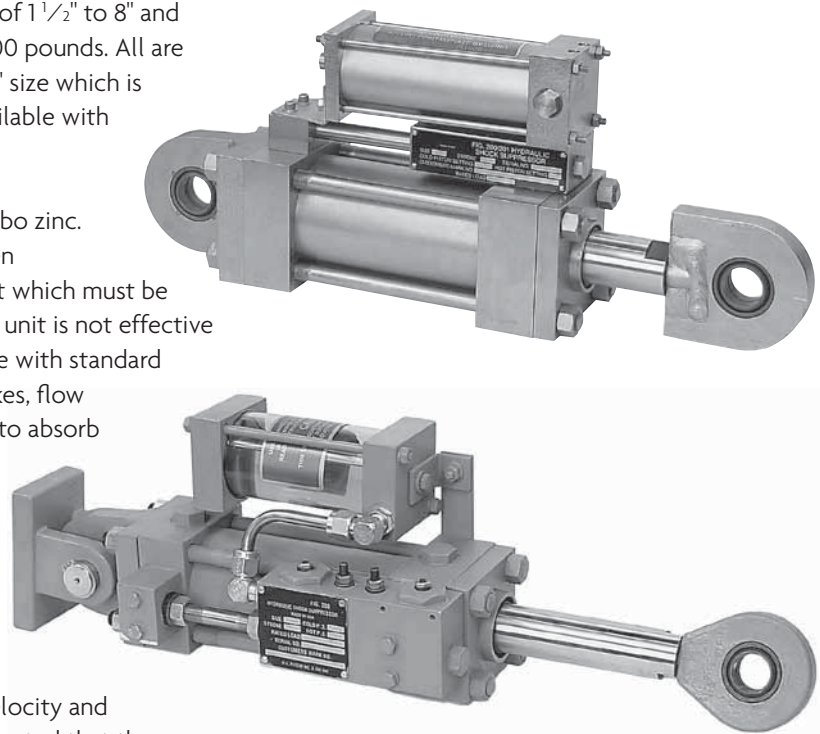

LOADS (LBS)	
Cylinder Size (in)	Max Load *
1½ (5" stroke)	3,000
1½ (10" stroke)	1,250
2½ (5", 10", 15" stroke)	12,500
2½ (20" stroke)	10,500
3¼	21,000
4	32,000
5	50,000
6	72,000
8	128,000

* Loads must not be applied outside a 10° included angle cone of action to the pipe clamp axis without special authorization.

Fig. 200, Fig. 201 Hydraulic

Snubber (cont.)

Upgrade Kits: Kits are available to upgrade existing snubbers with temperature compensating valves and/or pressurized reservoir.

How to size:

- Cylinder size:** Use table on page 199 to select cylinder bore size large enough to restrain expected load.
- Stroke:** Define expected movement of the pivot joining the suppressor with the equipment to be protected (cold to hot plus any abnormal movements). Determine maximum and minimum distances between this curve and the fixed pivot pin of the snubber. The minimum recommended stroke is 20% greater than the difference between these lengths.
Note: If erected position at the snubber's location on the equipment is outside of the range of normal cold-to-hot movement (e.g. cold pull of pipe), the snubber should not be installed until after the equipment is in its cold position. This eliminates the need of providing for the extra travel in the snubber's stroke. For 2 1/2" through 8" snubbers, standard strokes are 5", 10", 15", and 20". For the 1 1/2" snubber, 5" and 10" are the only standard strokes.
- Installed piston setting:** As indicated previously, the snubber should be installed at its cold piston position if possible. From the installed position, take extension (outward movement) of the piston rod as positive (+) and retraction as negative (-).
- Installed piston position =**

$$\left(\frac{\text{Stroke} - (\text{Algebraic Sum of Movements})}{2} \right)$$

To aid in measuring the piston position, we have shown a dimension, "Z". This dimension represents the distance between the cylinder head and the end of the rod when the rod is fully retracted. Whenever specifying the position at which the piston rod is to be set, the total dimension from the cylinder head to the end of the rod should be given. Thus, Piston Setting = Piston Position + Z.

- Assembly length:** Determine the installed "C" dimension by adding the installed piston position (not setting) to C minimum. Lay in take out dimensions E and/or B, and find required pin-to-pin snubber length. If a pin-to-pin length adjustment is desired, use Fig. 201. Calculate the required "W" dimension by subtracting (C installed + F) from the required pin-to-pin length. If this is less than W minimum, only a Fig. 200 can be used, and one of the attachments will have to be moved or shimmed to suit. If a Fig. 200 is to be used, make sure that the required pin-to-pin length is at least as great as (C installed + B). If neither a Fig. 200 nor a Fig. 201 can be accommodated, and the installation cannot be modified, consult your Anvil representative about designing a special or modified unit.

Ordering:

Ordering: Specify part number as follows:						
XXX	X	XX	X	X	X	X
Reservoir Orientation O=Does not apply for pressurized or remote U=Rod up D=Rod down or horizontal						
Reservoir Type L=Transparent (Polycarbonate) M=Metal (limited applications) P=Pressurized R=Remote						
Valve Type A=Adjustable T=Temperature Compensating						
Option (0,1,2, or 3), See Option Table Below						
Stroke (5, 10, 15, 20)						
Cylinder Size: 1 (1 1/2 Cyl.) 2 (2 1/2 Cyl.) 3 (3 1/4 Cyl.) 4 (4Cyl.) 5 (5Cyl.) 6 (6Cyl.) 8 (8 Cyl.)						
Figure No. (200 or 201), Also Specify: W Dimension when Specifying Fig 201 Pipe Clamp Size when Specifying Option 3 Surface Coating Cold and Hot Piston Settings.						

FIG. 200 & FIG. 201 OPTIONS	
Option	Consists of...
0	Fig 200: Basic unit (snubber) with pivot mount and one rear bracket.
	Fig. 201: Basic unit with extension piece and one rear bracket.
1	Option 0 plus cylinder eye.
2	Option 0 plus cylinder eye and additional rear bracket.
3	Option 0 plus cylinder eye and pipe clamp.

Straps
Pipe Supports
Trapeze
Pipe Shields & Saddles
Pipe Roll
Pipe Guides & Slides
Spring Hangers
Constant Supports
Vibration Control & Sway Brace
Sway Strut Assembly
Snubbers
Special Design Products
Application Examples
Master Format 3 Part Specs.
Technical Data
Index

Fig. 200, Fig. 201

Hydraulic Snubber (cont.)

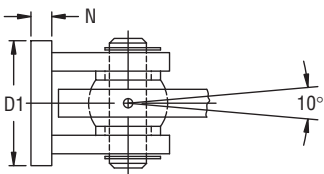
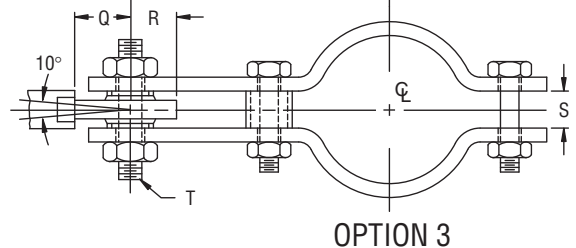
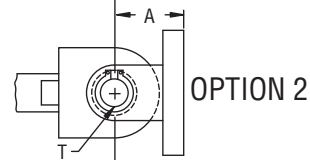
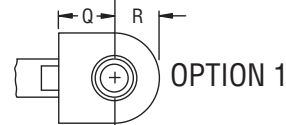
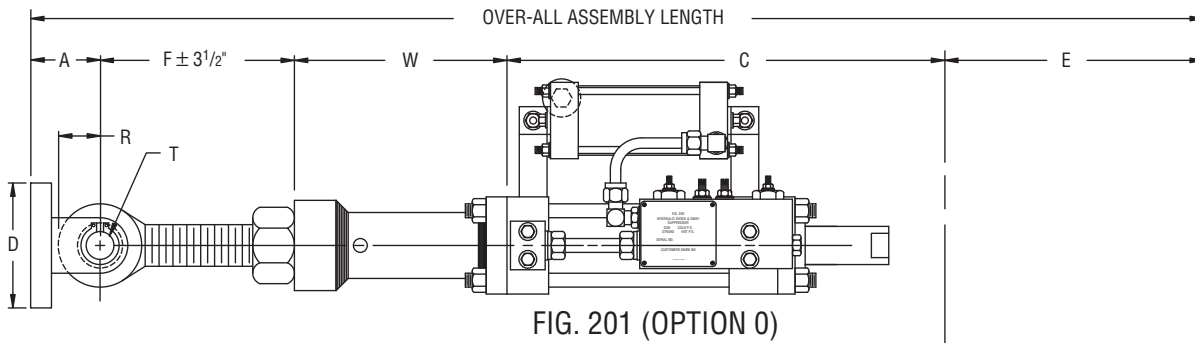
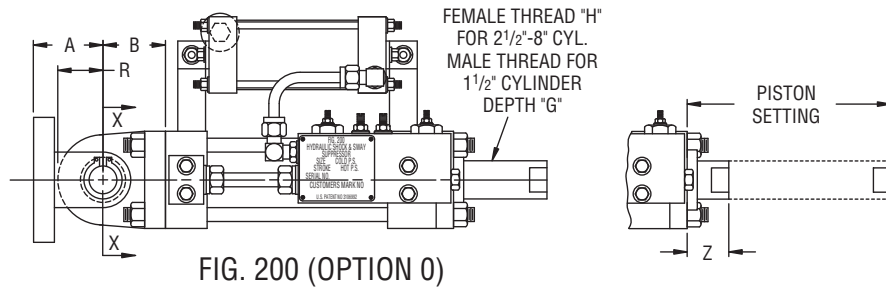
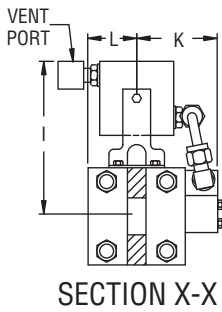

NOTE:
CYLINDER EYE
MAY BE ROTATED
TO ANY POSITION

Fig. 200, Fig. 201

Hydraulic Snubber (cont.)

FIG 200, 201: WEIGHT (LBS) • DIMENSIONS (IN)																									
Cylinder Bore	Stroke	Fig. 200 Wt.	A	B	C			D	D ₁	F	G	H	I			K	L	N	Q	R	S	T	W		Z
					Min	Mid	Max						Metal Res.	Trans. Res.	Press Res.								Min	Max	
1½	5	45	2½	1½	13⅞	15⅝	18⅞	2	2⅝	6	¾	⅝-18	5⅞	4⅜	4¾	2¾	2¼	⅝	2⅞	1⅞	1	¾	9½	75⅝	⅝
	10	49			18⅞	23⅞	28⅞																	65⅝	
2½	5	75	2½	2¼	13⅜	15⅞	18⅜	2	2⅞	7⅜	⅞	⅞-14	6¼	5⅞	5¾	3¼	1¾	¾	2	1⅝	1⅜	1	10⅜	94⅞	1
	10	81			18⅜	23⅜	28⅜																	84⅞	
	15	87			23⅜	30⅞	38⅜																	74⅞	
	20	93			28⅜	38⅜	48⅜																	64⅞	
3¼	5	121	3	3	14⅞	17⅞	19⅞	3	3⅜	7⅞	1⅞	1⅞-12	6⅞	5¾	6¾	3¾	2¼	¾	2½	2⅞	1⅞	1¼	10½	92	1⅞
	10	132			19⅞	24⅞	29⅞																	82	
	15	146			24⅞	32⅞	39⅞																	72	
	20	156			29⅞	39⅞	49⅞																	62	
4	5	177	4	3¾	16⅞	18⅝	21⅞	6⅞	4¼	9⅝	1½	1½-12	7⅞	6	7⅜	4	2½	1¼	3⅞	2½	2	1½	11½	89⅞	1⅞
	10	189			21⅞	26⅞	31⅞																	79⅞	
	15	206			26⅞	33⅝	41⅞																	69⅞	
	20	223			31⅞	41⅞	51⅞																	59⅞	
5	5	235	5	4½	18	20½	23	7⅞	5⅝	10⅞	1⅞	1⅞-12	8½	7	9⅞	4¾	3¼	1¾	4	3⅞	2⅝	1¾	12	86⅞	1⅞
	10	256			23	28	33																	76⅞	
	15	277			28	35½	43																	66⅞	
	20	298			33	43	53																	56⅞	
6	5	292	5¾	5½	19¾	22¼	24¾	9⅞	6¼	11⅝	2¼	2¼-12	9⅞	7⅝	10⅞	5¼	3⅞	2	4⅝	3½	2¾	2	13⅜	83⅞	1¾
	10	320			24¾	29¾	34¾																	73⅞	
	15	348			29¾	37¼	44¾																	63⅞	
	20	375			34¾	44¾	54¾																	53⅞	
8	5	515	7¼	6	23½	26	28½	14	8¾	14½	4	3-12	12½	N/A	13⅞	8½	4⅞	2¼	6¾	4¾	-	2½	14½	75½	2¼
	10	575			28½	33½	38½																	65½	
	15	640			33½	41	48½																	55½	
	20	705			38½	48½	58½																	45½	

FIG 200, 201: DIMENSIONS (IN)												
Pipe Size	E-Take Out						Clamp Stock Size					
	Cylinder Bore						Cylinder Bore					
	1½	2½	3¼	4	5	6	1½	2½	3¼	4	5	6
2	6	6⅞	-	-	-	-	⅜ x 1¾	½ x 2½	-	-	-	-
2½	7	7	-	-	-	-	⅜ x 1¾	½ x 2½	-	-	-	-
3	7	7	-	-	-	-	⅜ x 1¾	½ x 2½	-	-	-	-
3½	7	7	-	-	-	-	⅜ x 1¾	½ x 2½	-	-	-	-
4	7¼	7¼	-	-	-	-	½ x 1½	⅝ x 2½	-	-	-	-
5	7¾	7¾	9⅞	10	-	-	½ x 1½	⅝ x 2½	¾ x 3	¾ x 5	-	-
6	8⅞	8⅞	10	10	11⅞	-	½ x 2	⅝ x 3	¾ x 4	¾ x 5	1 x 5	-
8	9⅞	9⅞	11¼	11¼	12⅞	-	½ x 2½	¾ x 3	¾ x 5	1 x 5	1 x 6	-
10	10½	10½	12¾	12¾	14¼	-	⅝ x 2½	¾ x 4	¾ x 6	1 x 5	1 x 7	-
12	11⅞	11⅞	13⅞	13⅞	15⅞	-	⅝ x 2½	¾ x 5	1 x 5	1 x 6	1 x 7	-
14	12⅞	12⅞	14½	14½	16	-	⅝ x 2½	¾ x 5	1 x 5	1 x 7	1¼ x 6	-
16	13⅞	13⅞	15¼	15¼	17⅞	-	⅝ x 3	¾ x 6	1 x 5	1 x 7	1¼ x 6	-
18	14⅝	14⅝	16⅞	16⅞	18¼	-	¾ x 3	1 x 5	1 x 6	1 x 7	1¼ x 7	-
20	15¾	15¾	17¾	17¾	19¼	19¼	¾ x 3	1 x 5	1 x 7	1¼ x 6	1¼ x 8	1½ x 8
24	18⅞	18⅞	19⅞	19⅞	21¾	21¾	¾ x 4	1 x 5	1 x 7	1¼ x 6	1¼ x 9	1½ x 9
30	21¼	21¼	23	23	25	25	¾ x 4	1 x 6	1¼ x 6	1¼ x 8	1½ x 8	1¾ x 10
36	24	24	26½	26½	28⅞	28⅞	¾ x 5	1 x 7	1¼ x 6	1¼ x 9	1½ x 10	1¾ x 10

Note: "E" Dimensions are for carbon steel clamps only, with maximum insulation of 4" and temperature of 650°.

Fig. 312

Tapered Pin

Size Range: $\frac{3}{8}$ " through $2\frac{1}{2}$ "

Service: Used as a replacement to standard rear bracket load pin to facilitate easy removal at time of rebuild or testing. May be supplied with new orders, when specified.

How to size: Select size consistent with load pin diameter for Fig. 200/201 or Fig. 3306/3307.

Features:

- Designed to sharply reduce the time necessary to remove a badly corroded conventional pin and may also eliminate damage to the bushing and bracket assembly, particularly if the pin and bracket are corroded.
- Minimizes "free play" between pin to pin.

Ordering: Specify figure number, nominal pin size and name.

Installation: Shipped assembled. Remove nuts and washer. Loosen sleeve on pin and install sleeve/pin. Re-install washer and one nut. Tighten hex nut to snug. Install second nut.

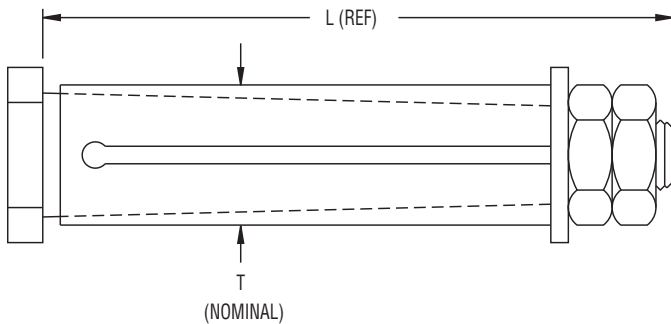

FIG 312: LOADS (LBS) • DIMENSIONS (IN)

Nominal Dia. T	Max Load	L	Compatible With	
			Fig. 200/201	Fig. 3306/3307
$\frac{3}{8}$	650	$1\frac{61}{64}$	–	$\frac{1}{4}$ & $\frac{1}{2}$
$\frac{1}{2}$	1,500	$2\frac{3}{8}$	–	1
$\frac{3}{4}$	6,000	$3\frac{3}{8}$	$1\frac{1}{2}$	3
1	15,000	$4\frac{3}{8}$	$2\frac{1}{2}$	10
$1\frac{1}{4}$	21,000	$4\frac{1}{2}$	$3\frac{1}{4}$	–
$1\frac{1}{2}$	50,000	$7\frac{1}{8}$	4	35
$1\frac{3}{4}$	50,000	$6\frac{3}{4}$	5	–
2	72,000	$7\frac{3}{4}$	6	–
$2\frac{1}{2}$	128,000	$9\frac{3}{8}$	8	100

The load must be applied by a spherical bearing.

Fig. 38 SD

Half Clamp

This product is a special design per customer requirements. Contact Anvil Intl. for further information and how to order.

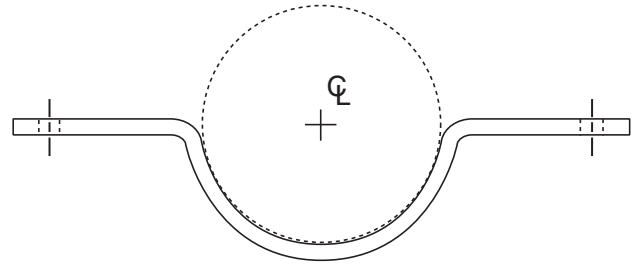

Fig. 53 SD

Welding Lug for L.R. Elbow

This product is a special design per customer requirements. Contact Anvil Intl. for further information and how to order sizes not shown. Local pipe wall stress should be evaluated.

FIG. 53SD: DIMENSIONS (IN)						
Pipe Size	Rod Size A	C Rod Take Out	T	D	R	H Max. Dia.
2½	¾	7 ⁵ / ₁₆	½	3½	1½	1 ⁵ / ₁₆
3		7 ⁷ / ₁₆				1 ¹ / ₁₆
3½	7/8	7½				1 ³ / ₈
4		7 ⁹ / ₁₆				1½
6		7 ⁷ / ₁₆				1 ³ / ₈
8	1	7 ⁷ / ₁₆				5/8
10	1¼	7 ⁵ / ₁₆	¾	7	3	1¾
12	1½	7 ⁷ / ₈				

* Based on maximum 4" insulation.

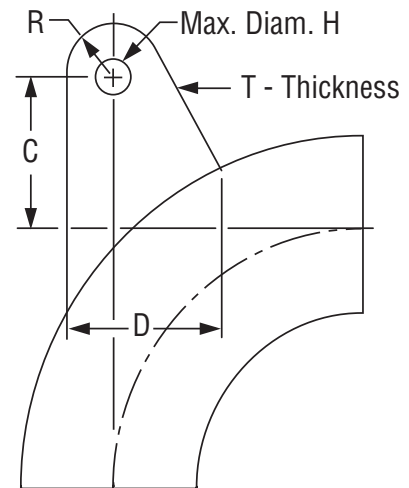

Fig. 71 SD

Double Roll Horizontal Traveler

This product is a special design per customer requirements. Contact Anvil Intl. for further information and how to order.

The Anvil Fig. 71SD horizontal traveler facilitates the supporting of piping systems subject to linear horizontal movements where head room is limited. Designed for use with Anvil Variable Spring Hangers or Constant Supports it can also be used in conjunction with a rigid type hanger assembly.

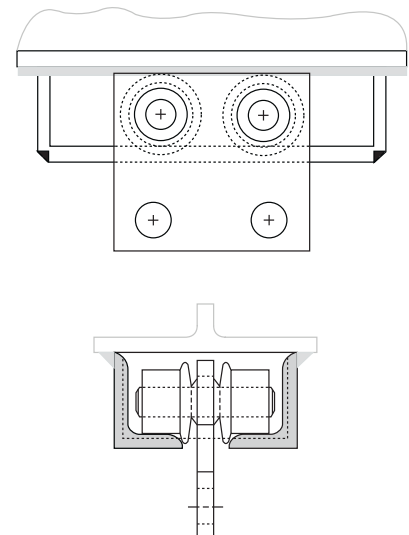

Fig. 72 SD

Dual Direction Horizontal Traveler

This product is a special design per customer requirements. Contact Anvil International for further information and how to order.

The Anvil Fig. 72SD Horizontal Traveler facilitates the supporting of piping systems subject to dual directional horizontal movements where head room is limited. Designed for use with Anvil Variable Spring Hangers or Constant Supports, it can also be used in conjunction with a rigid type hanger assembly.

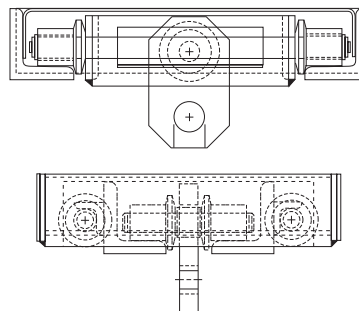

Fig. 75 SD

Flat Roller With Saddle

This product is a special design per customer requirements. Contact Anvil Intl. for further information and how to order. Pipe sizes 4" through 42"

Note: Type B Saddle - If attached to alloy pipe, furnish material specification applicable to the pipe. (Alloy Bars furnished for attachment to alloy pipe only.)

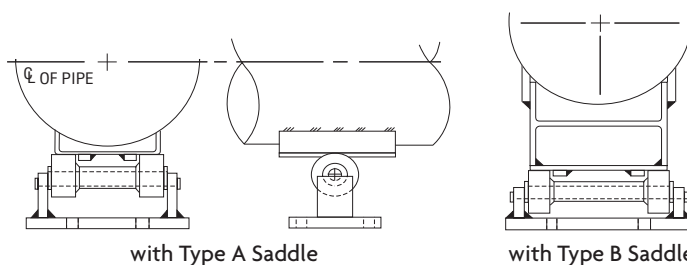

Fig. 76 SD

Fabricated Roller for Large Diameter Pipe

This product is a special design per customer requirements. Contact Anvil International for further information and how to order.

Installation: The two piece fabricated roller is designed for one of the two rollers on each side of the assembly to be in contact with the pipe.

FIG. 76SD: LOADS (LBS) • DIMENSIONS (IN)						
Steel Pipe Size	Max Load	A	B	C	D	E
30	60,000	23 ¹ / ₈	13 ⁵ / ₈	8 ³ / ₁₆	8 ¹⁵ / ₁₆	0
36		26			9 ⁹ / ₁₆	1
42		28 ⁷ / ₈			10 ¹⁵ / ₁₆	2
46		30 ³ / ₄			11 ¹¹ / ₁₆	2 ³ / ₄
46	60,000	31 ³ / ₁₆	16 ¹ / ₄	10 ¹³ / ₁₆	12 ¹³ / ₁₆	1 ¹ / ₄
48		32 ¹ / ₁₆			13 ³ / ₄	1 ¹¹ / ₁₆
54		34 ¹⁵ / ₁₆			14 ⁵ / ₁₆	2 ³ / ₄
60		37 ¹¹ / ₁₆			15 ¹ / ₂	3 ¹⁵ / ₁₆
66		40 ⁹ / ₁₆			16 ³ / ₁₆	5
72		43 ³ / ₈			17 ⁵ / ₈	6 ¹ / ₁₆

FIG. 76SD: LOADS (LBS) • DIMENSIONS (IN)						
C.I./D.I. Pipe Size	Max Load	A	B	C	D	E
30	60,000	24 ³ / ₁₆	13 ⁵ / ₈	8 ³ / ₁₆	9 ¹ / ₁₆	1 ¹ / ₄
36		27 ³ / ₁₆			10 ³ / ₁₆	1 ³ / ₈
42		30 ¹ / ₈			11 ⁵ / ₁₆	2 ³ / ₈
48		33 ¹ / ₂			13 ⁹ / ₁₆	2

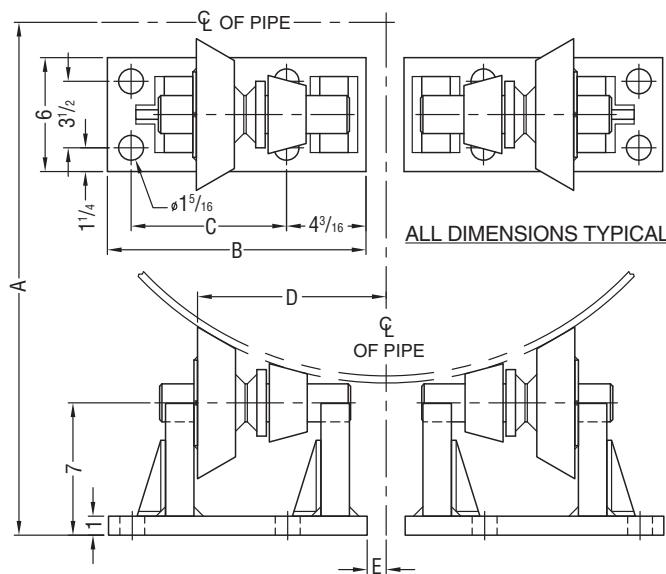

Fig. 40 SD

Riser Clamp

Material: Carbon steel chrome molybdenum or stainless steel.

Finish: Plain or Galvanized

Maximum Temperature: As required.

Ordering: Specify figure number 40SD, riser clamp special design, material, exact pipe size, load, operating temperature, insulation thickness, C-C dimension, rod diameter, finish and if connected to a spring or rigid connection.

Service: Riser clamps are used for the support of vertical piping. Load is carried by shear lugs which are welded to the pipe. Shear lugs not provided.

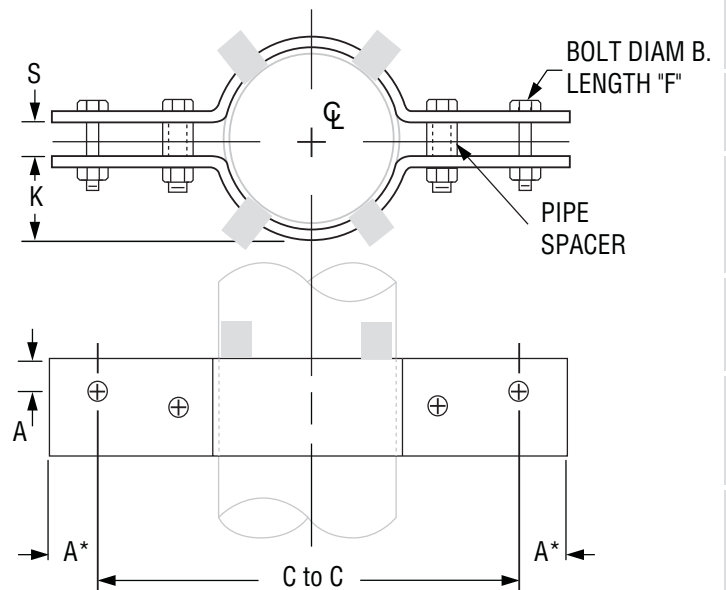

Fig. 41 SD

Non-Standard Three Bolt Pipe Clamp

Ordering:

Specify Fig. 41SD double bolt pipe clamp, material specification, pipe size, load, operating temperature, insulation thickness and finish.

Alloy clamps, unless otherwise specified, will be furnished with alloy studs made from ASTM A 193-B7 stud stock and ASTM A 194-Gr. 2H hex nuts.

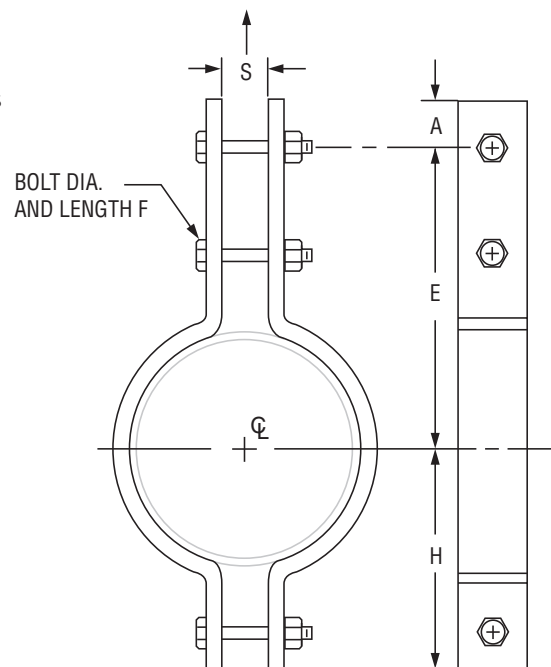

Fig. 42 SD

Non-Standard Two Bolt Pipe Clamp

Ordering:

Specify Fig. 42SD pipe clamp, material specification, pipe size, load, temperature and finish.

Alloy clamps, unless otherwise specified, will be furnished with alloy studs made from ASTM A 193-B7 stud stock and ASTM A 194-Gr. 2H hex nuts.

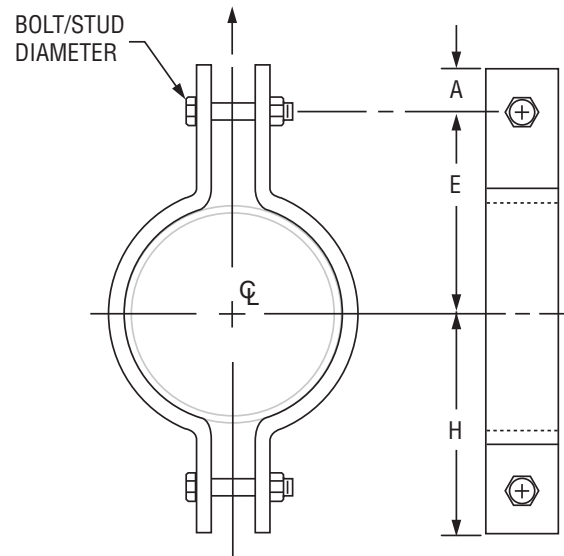

Constant Hanger Assemblies

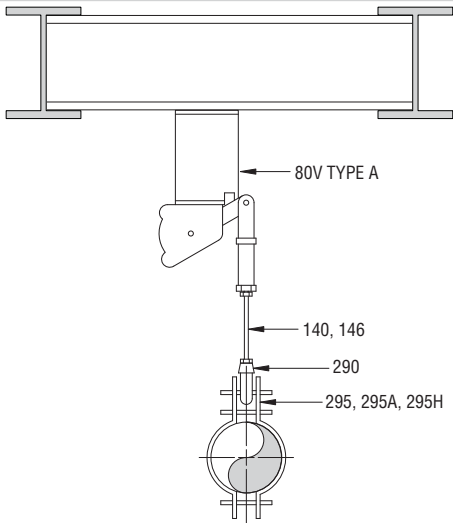

Fig_80V_Type_A .DWG, .DXF, or .EPS

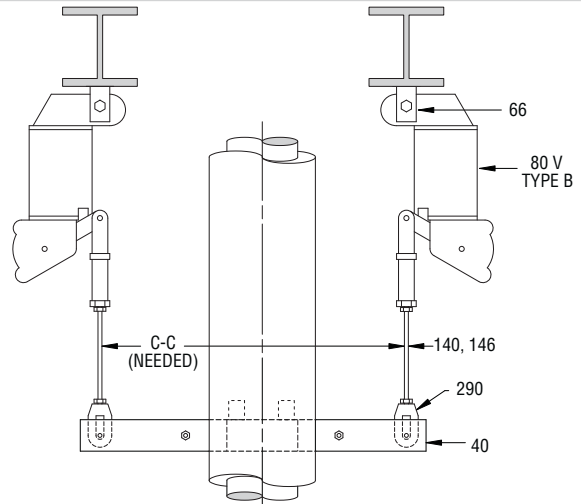

Fig_80V_Type_B .DWG, .DXF, or .EPS

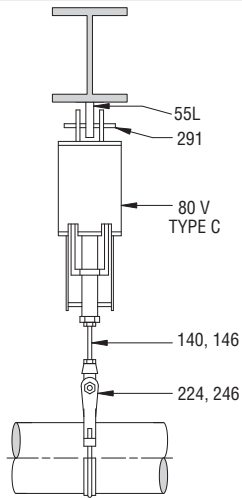

Fig_80V_Type_C .DWG, .DXF, or .EPS

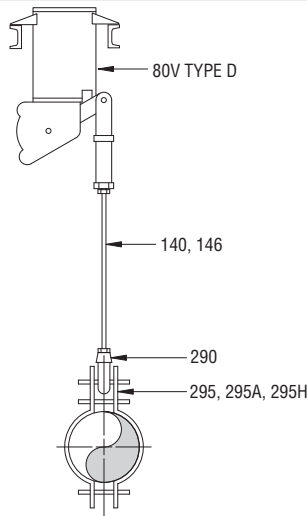

Fig_80V_Type_D .DWG, .DXF, or .EPS

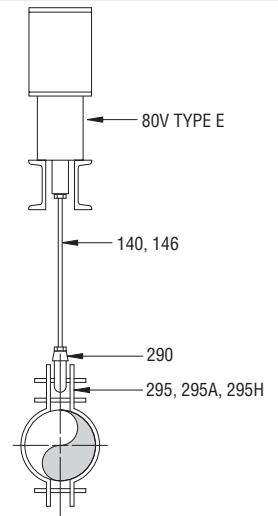

Fig_80V_Type_E .DWG, .DXF, or .EPS

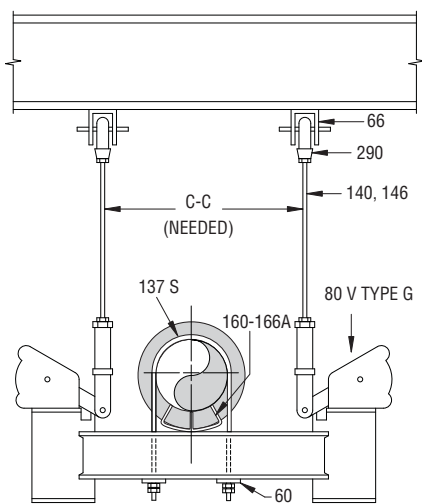

Fig_80V_Type_G .DWG, .DXF, or .EPS

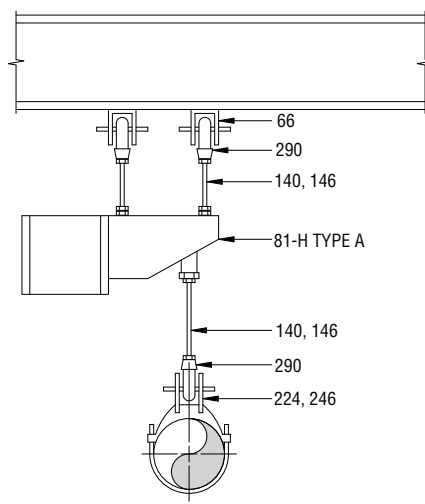

Fig_81H_Type_A_224 .DWG, .DXF, or .EPS

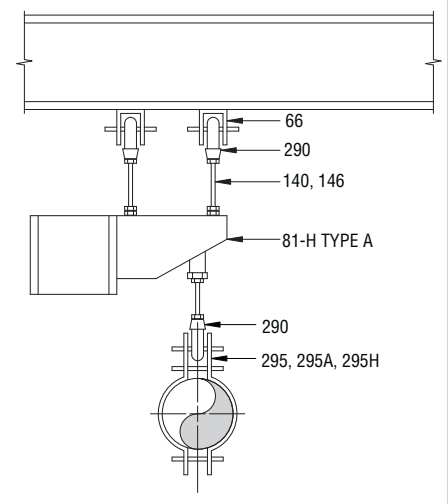
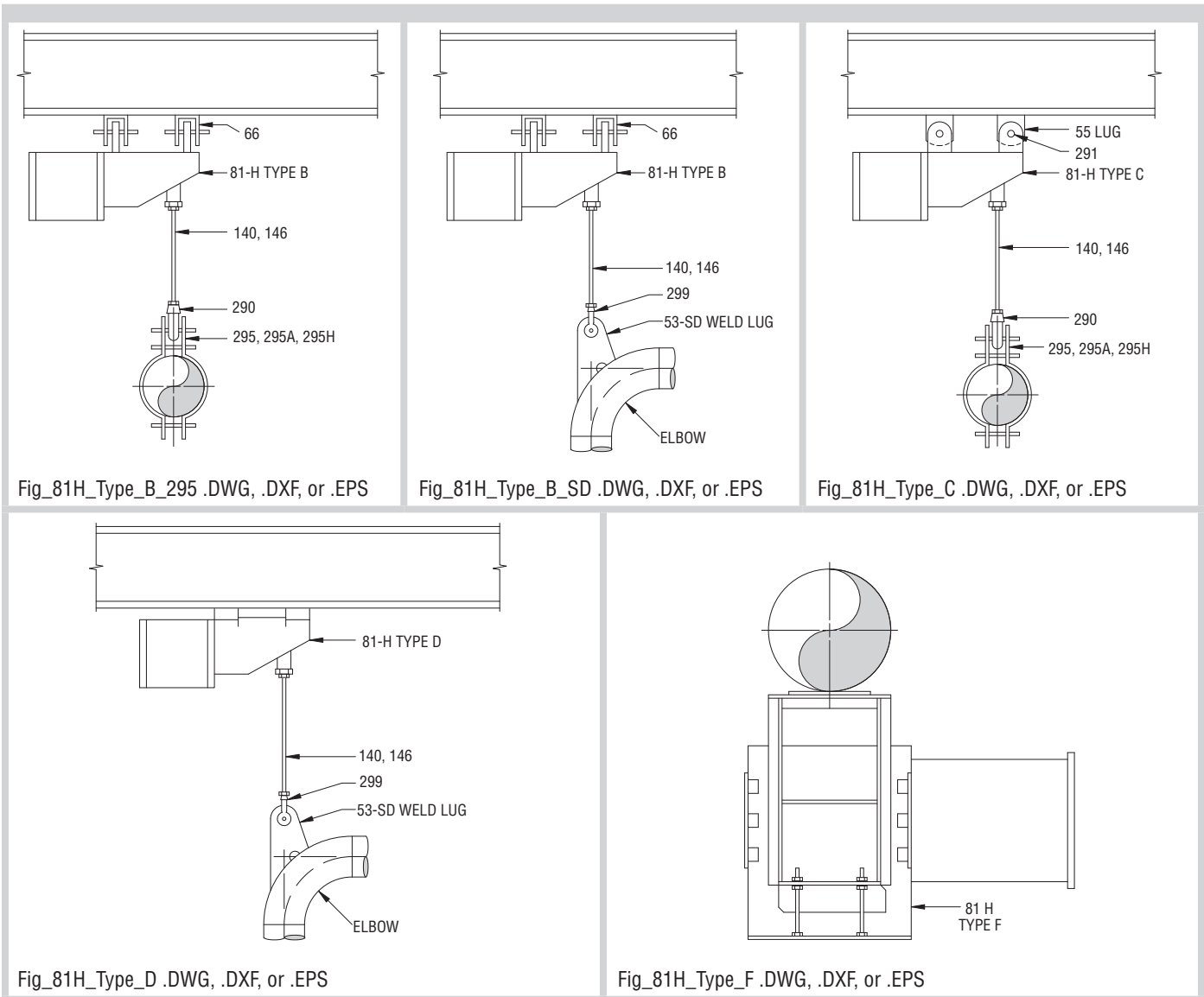

Fig_81H_Type_A_295 .DWG, .DXF, or .EPS

Each of these drawings are available on the Anvil web site in CAD format. The file name at the bottom of each box refers to that CAD file.

APPLICATION ASSEMBLY EXAMPLES

Constant Hanger Assemblies (continued)



Each of these drawings are available on the Anvil web site in CAD format. The file name at the bottom of each box refers to that CAD file.

Spring Hanger Assemblies

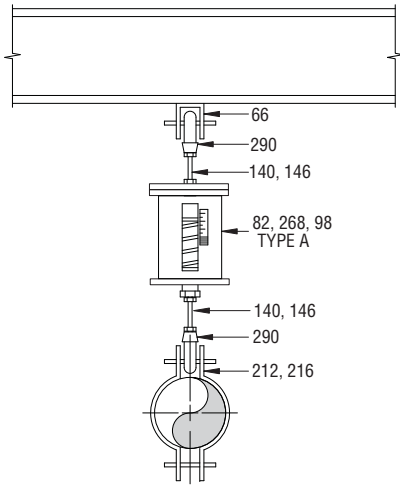

SH_Type_A_212 .DWG, .DXF, or .EPS

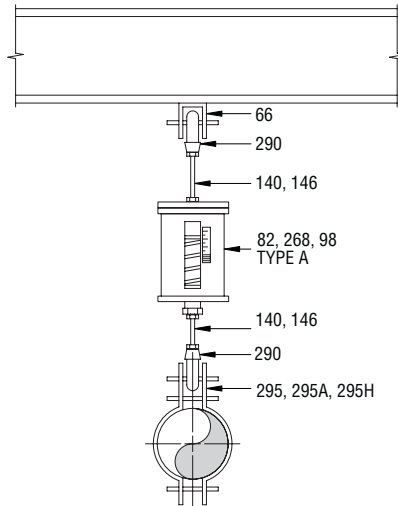

SH_Type_A_295 .DWG, .DXF, or .EPS

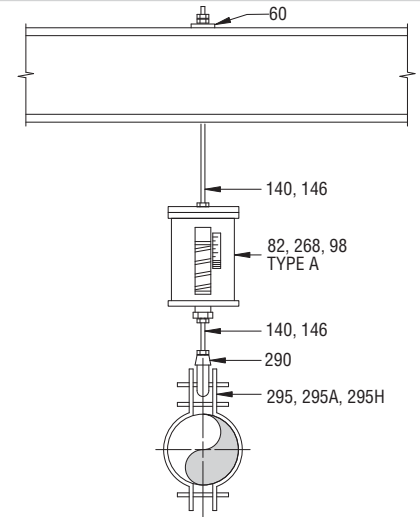

SH_Type_A_60 .DWG, .DXF, or .EPS

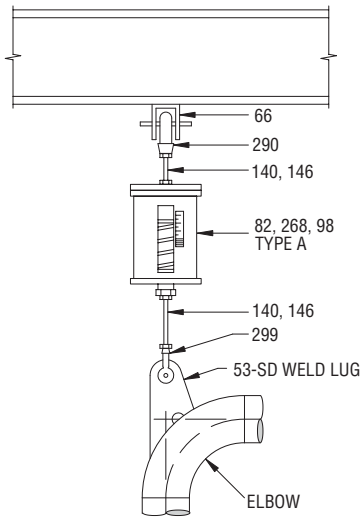

SH_Type_A_53SD .DWG, .DXF, or .EPS

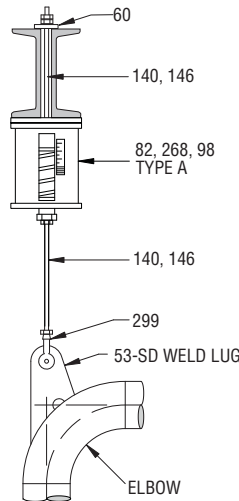

SH_Type_A_53SD_60 .DWG, .DXF, or .EPS

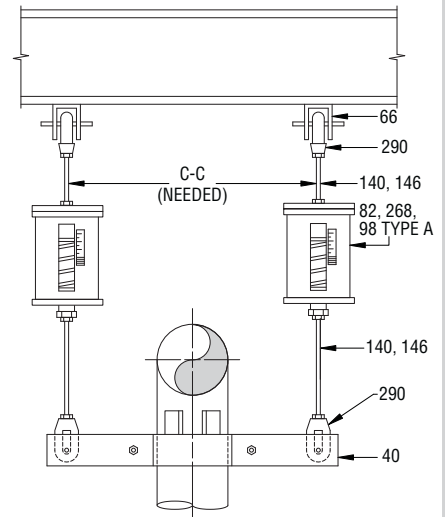

SH_Type_A_Riser .DWG, .DXF, or .EPS

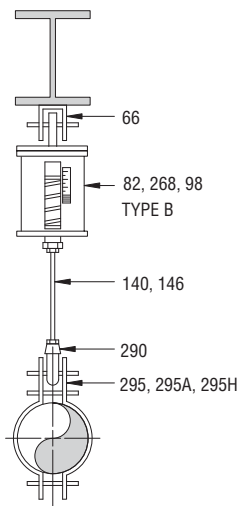

SH_Type_B_295 .DWG, .DXF, or .EPS

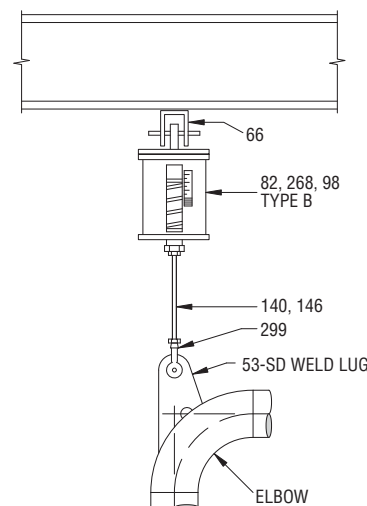

SH_Type_B_53SD .DWG, .DXF, or .EPS

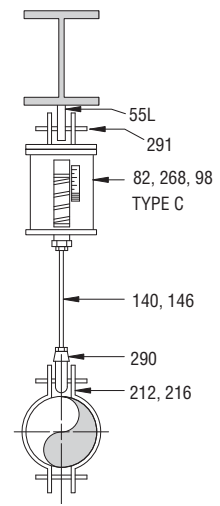

SH_Type_C_212 .DWG, .DXF, or .EPS

Each of these drawings are available on the Anvil web site in CAD format. The file name at the bottom of each box refers to that CAD file.

APPLICATION ASSEMBLY EXAMPLES

Spring Hanger Assemblies (continued)

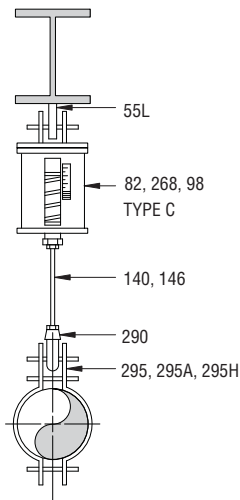

SH_Type_C_295 .DWG, .DXF, or .EPS

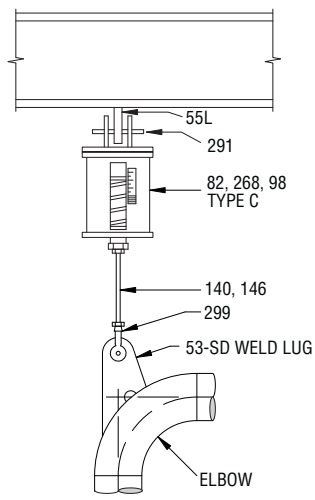

SH_Type_C_53SD .DWG, .DXF, or .EPS

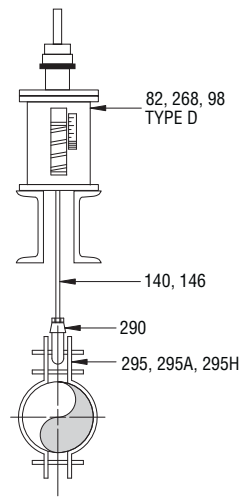

SH_Type_D_295 .DWG, .DXF, or .EPS

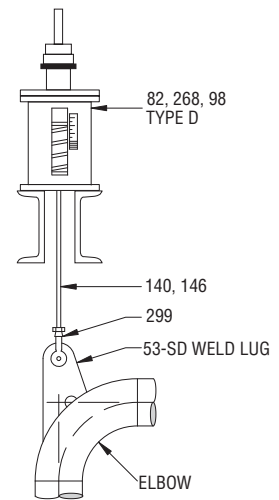

SH_Type_D_53SD .DWG, .DXF, or .EPS

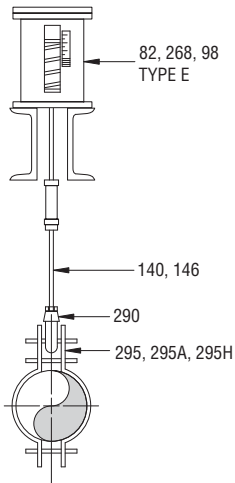

SH_Type_E .DWG, .DXF, or .EPS

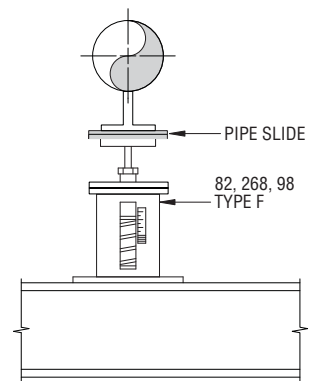

SH_Type_F_PipeSlide .DWG, .DXF, or .EPS

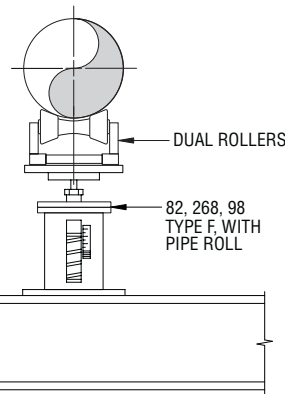

SH_Type_F_PipeRoller .DWG, .DXF, or .EPS

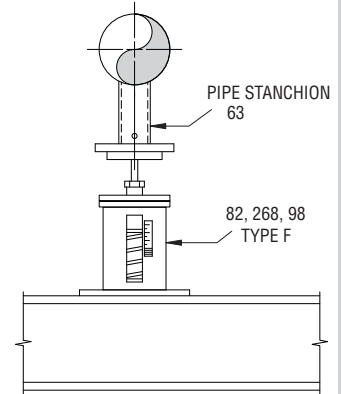

SH_Type_F_63 .DWG, .DXF, or .EPS

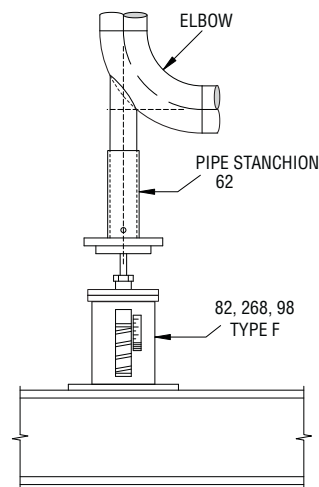

SH_Type_F_62 .DWG, .DXF, or .EPS

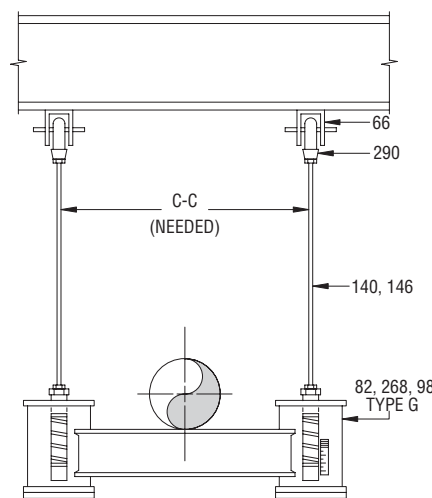

SH_Type_G .DWG, .DXF, or .EPS

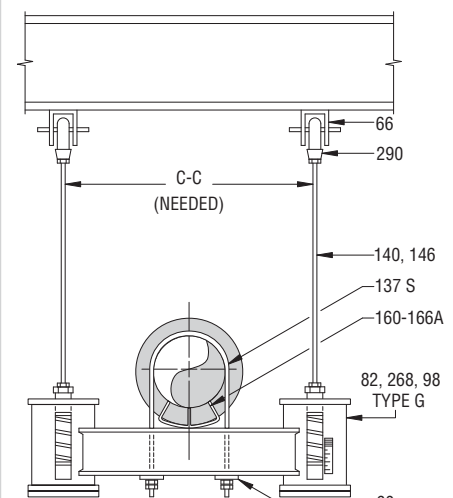

SH_Type_G_160-137S .DWG, .DXF, or .EPS

Each of these drawings are available on the Anvil web site in CAD format. The file name at the bottom of each box refers to that CAD file.

Rigid Hanger Assemblies

<p>RH_40_290_230_Riser .DWG, .DXF, or .EPS</p>	<p>RH_212_290_140_66 .DWG, .DXF, or .EPS</p>	<p>RH_295_290_230 .DWG, .DXF, or .EPS</p>	<p>RH_53SD_299_290 .DWG, .DXF, or .EPS</p>
<p>RH_260_140_60 .DWG, .DXF, or .EPS</p>	<p>RH_212_290 .DWG, .DXF, or .EPS</p>	<p>RH_212_290_299_55 .DWG, .DXF, or .EPS</p>	<p>RH_295_290_299_55 .DWG, .DXF, or .EPS</p>
<p>RH_45_137S_66_Trapeze .DWG, .DXF, or .EPS</p>		<p>RH_45_137S_60_Trapeze .DWG, .DXF, or .EPS</p>	

Each of these drawings are available on the Anvil web site in CAD format. The file name at the bottom of each box refers to that CAD file.

APPLICATION ASSEMBLY EXAMPLES

Rigid Hanger Assemblies (continued)

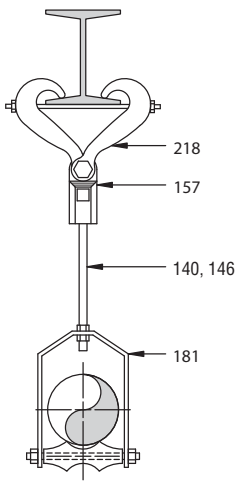
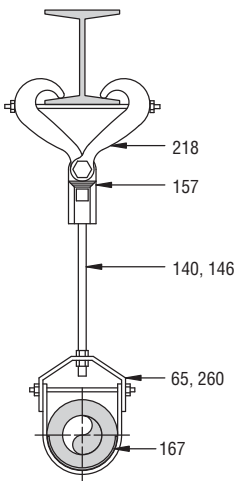
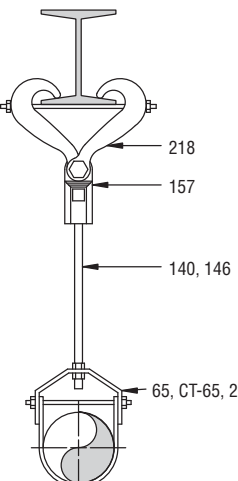
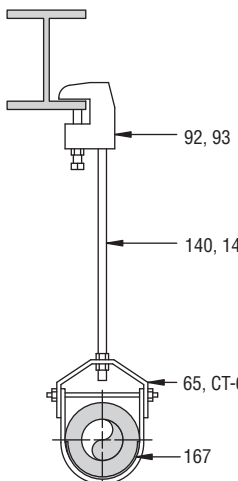
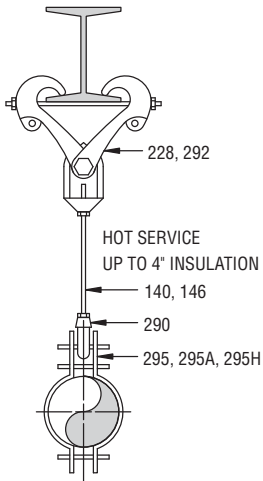
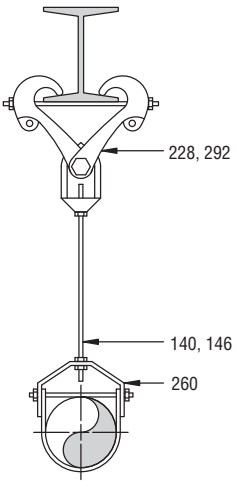
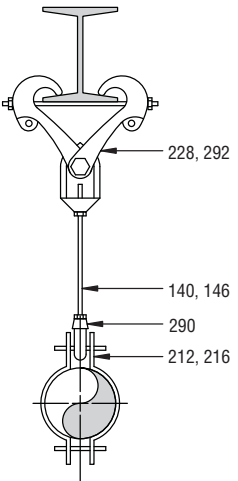
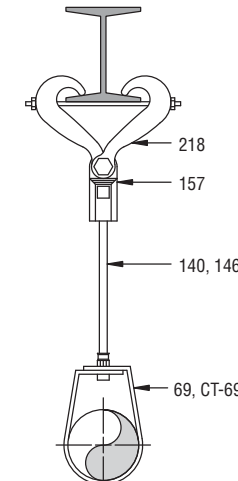
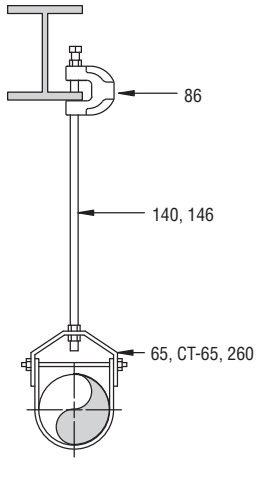
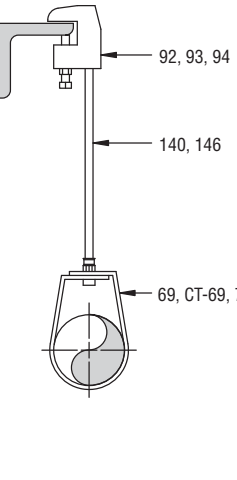
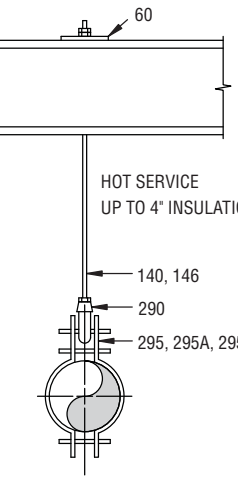
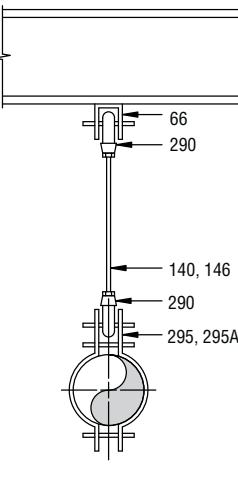
 <p>RH_181_157_218 .DWG, .DXF, or .EPS</p>	 <p>RH_167_65_157_218 .DWG, .DXF, or .EPS</p>	 <p>RH_65_157_218 .DWG, .DXF, or .EPS</p>	 <p>RH_167_65_92 .DWG, .DXF, or .EPS</p>
 <p>RH_295_290_228 .DWG, .DXF, or .EPS</p>	 <p>RH_260_228 .DWG, .DXF, or .EPS</p>	 <p>RH_212_290_228 .DWG, .DXF, or .EPS</p>	 <p>RH_69_157_218 .DWG, .DXF, or .EPS</p>
 <p>RH_65_86 .DWG, .DXF, or .EPS</p>	 <p>RH_69_92 .DWG, .DXF, or .EPS</p>	 <p>RH_295_290_60 .DWG, .DXF, or .EPS</p>	 <p>RH_295_290_66 .DWG, .DXF, or .EPS</p>

Each of these drawings are available on the Anvil web site in CAD format. The file name at the bottom of each box refers to that CAD file.

Rigid Hanger Assemblies (continued)

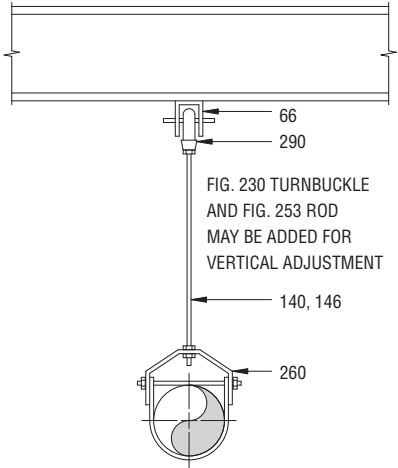
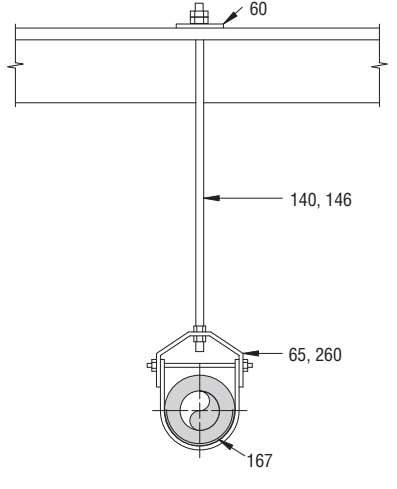
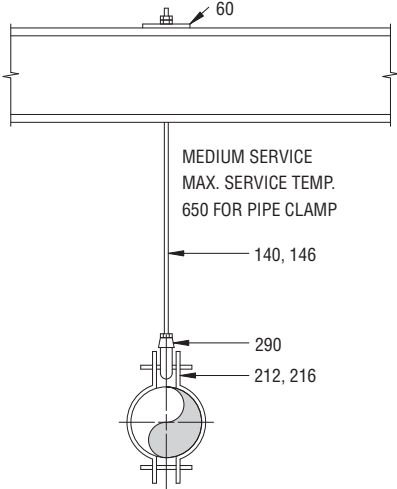
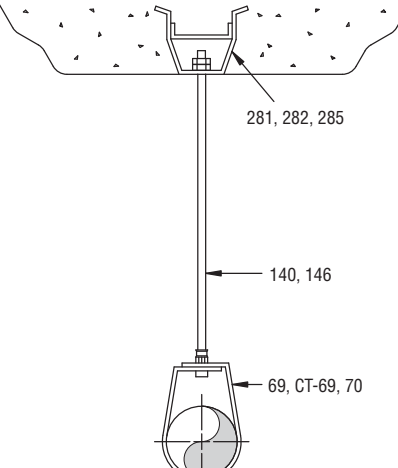
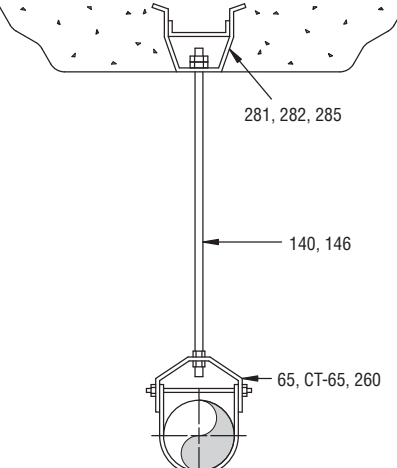
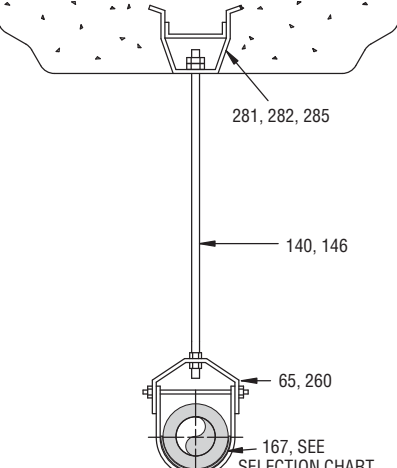
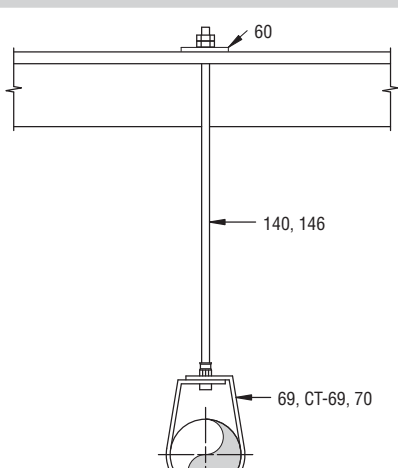
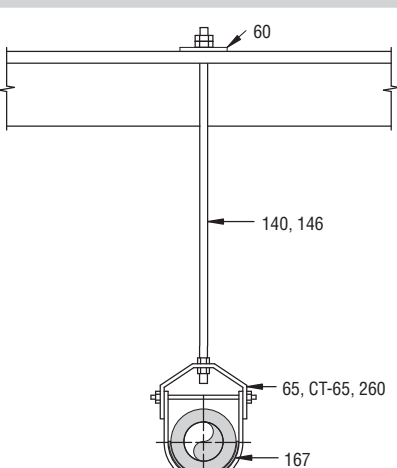
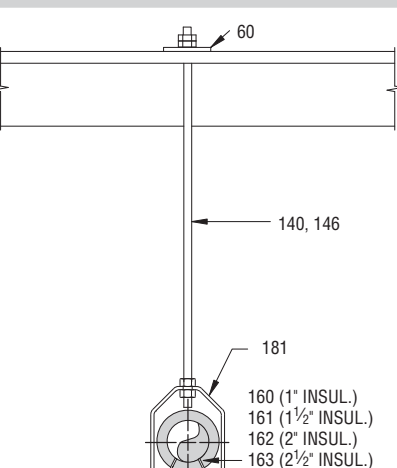
 <p>FIG. 230 TURNBUCKLE AND FIG. 253 ROD MAY BE ADDED FOR VERTICAL ADJUSTMENT</p> <p>66 290 140, 146 260</p>	 <p>60 140, 146 65, 260 167</p>	 <p>60 140, 146 290 212, 216</p> <p>MEDIUM SERVICE MAX. SERVICE TEMP. 650 FOR PIPE CLAMP</p>
 <p>281, 282, 285 140, 146 69, CT-69, 70</p>	 <p>281, 282, 285 140, 146 65, CT-65, 260</p>	 <p>281, 282, 285 140, 146 65, 260 167, SEE SELECTION CHART</p>
 <p>60 140, 146 69, CT-69, 70</p>	 <p>60 140, 146 65, CT-65, 260 167</p>	 <p>60 140, 146 181 160 (1" INSUL.) 161 (1 1/2" INSUL.) 162 (2" INSUL.) 163 (2 1/2" INSUL.) 164 (3" INSUL.) 165 (4" INSUL.)</p>
<p>RH_260_290_66 .DWG, .DXF, or .EPS</p>	<p>RH_167_65_60 .DWG, .DXF, or .EPS</p>	<p>RH_212_290_60 .DWG, .DXF, or .EPS</p>
<p>RH_69_281_CI .DWG, .DXF, or .EPS</p>	<p>RH_65_281_CI .DWG, .DXF, or .EPS</p>	<p>RH_167_65_281_CI .DWG, .DXF, or .EPS</p>
<p>RH_69_60 .DWG, .DXF, or .EPS</p>	<p>RH_160_181_60 .DWG, .DXF, or .EPS</p>	<p>RH_167_260_60 .DWG, .DXF, or .EPS</p>

Each of these drawings are available on the Anvil web site in CAD format. The file name at the bottom of each box refers to that CAD file.

APPLICATION ASSEMBLY EXAMPLES

Rigid Hanger Assemblies (continued)

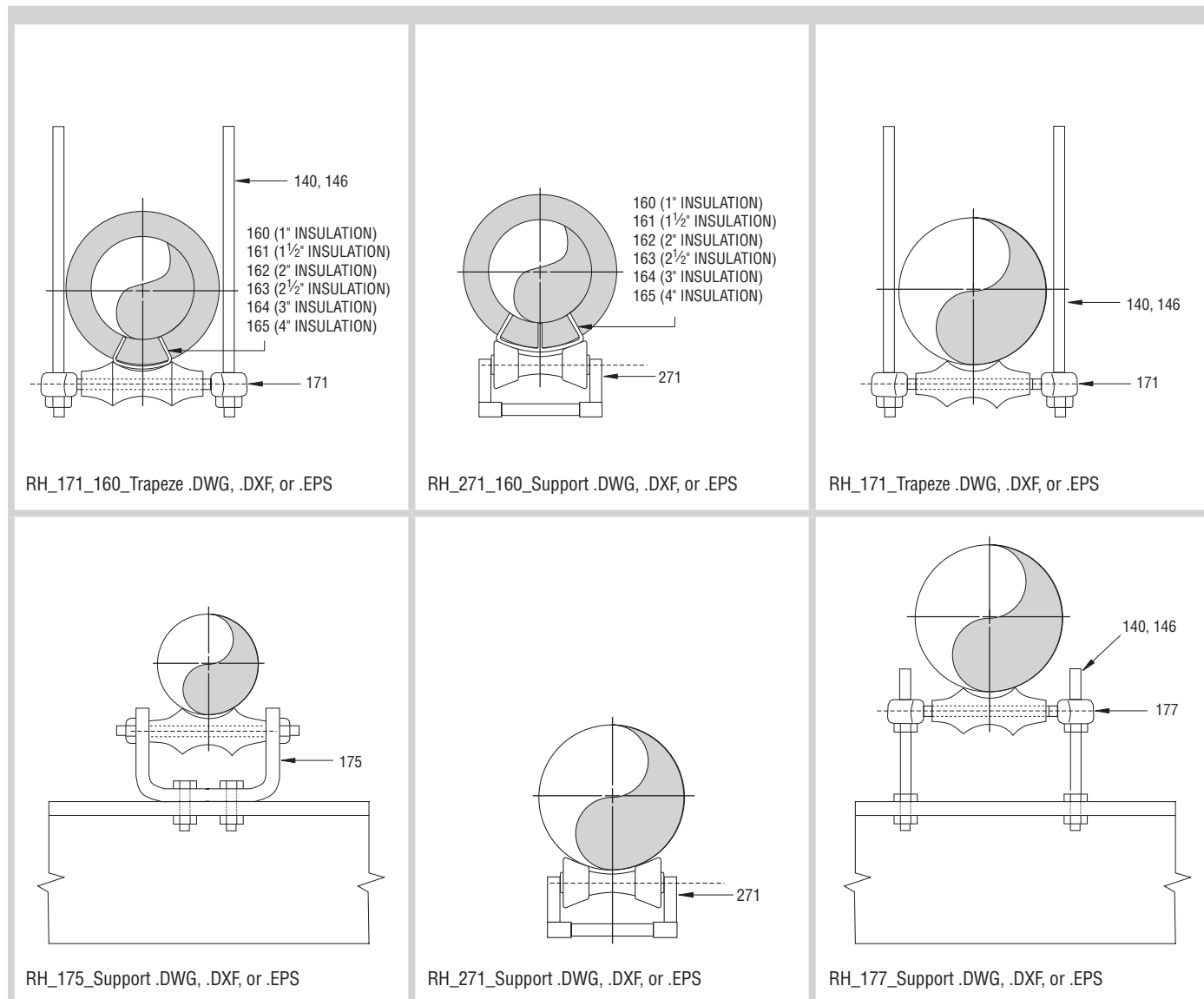

Each of these drawings are available on the Anvil web site in CAD format. The file name at the bottom of each box refers to that CAD file.

PIPE HANGER SPECIFICATIONS

1. SCOPE

This specification shall apply for the design and fabrication of all hangers, supports, anchors, and guides. Where piping design is such that exceptions to this specification are necessary, the particular system will be identified, and the exceptions clearly listed through an addendum which will be made a part of the specification.

2. DESIGN

- (a) All supports and parts shall conform to the latest requirements of the ASME Code for Pressure Piping B31.1 and MSS Standard Practice SP-58, SP-69, SP-89 and SP-90 except as supplemented or modified by the requirements of this specification.
- (b) Designs generally accepted as exemplifying good engineering practice, using stock or production parts, shall be utilized wherever possible.
- (c) Accurate weight balance calculations shall be made to determine the required supporting force at each hanger location and the pipe weight load at each equipment connection.
- (d) Pipe hangers shall be capable of supporting the pipe in all conditions of operation. They shall allow free expansion and contraction of the piping, and prevent excessive stress resulting from transferred weight being introduced into the pipe or connected equipment.
- (e) Wherever possible, pipe attachments for horizontal piping shall be pipe clamps.
- (f) For critical high-temperature piping, at hanger locations where the vertical movement of the piping is $\frac{1}{2}$ " or more, or where it is necessary to avoid the transfer of load to adjacent hangers or connected equipment, pipe hangers shall be an approved constant support design, as Anvil Fig. 80-V and Fig. 81-H Constant Support Hangers, or equal.

Where transfer of load to adjacent hangers or equipment is not critical, and where the vertical movement of the piping is less than $\frac{1}{2}$ ", Variable Spring Hangers may be used, provided the variation in supporting effect does not exceed 25% of the calculated piping load through its total vertical travel.

- (g) The total travel for Constant Support Hangers will be equal to actual travel plus 20%. In no case will the difference between actual and total travel be less than 1". The Constant Support Hanger will have travel scales on both sides of the support frame to accommodate inspections.

- (h) Constant Support Hanger should be individually calibrated before shipment to support the exact load specified. The calibration record of constant support shall be maintained for a period of 20 years to assist the customer in any redesign of the piping system. Witness marks shall be stamped on the Load Adjustment Scale to establish factory calibration reference point.
- (i) In addition to the requirements of ASTM A125 all alloy springs shall be shot peened and examined by magnetic particle. The spring rate tolerance shall be $\pm 5\%$. All three critical parameters (free height, spring rate and loaded height) of spring coils must be tested for. Each spring coiled must be purchased with a C.M.T.R. and be of domestic manufacture.
- (j) Constant Supports should have a wide range of load adjustability. No less than 10% of this adjustability should be provided either side of the calibrated load for plus or minus field adjustment. Load adjustment scale shall be provided to aid the field in accurate adjustment of loads. Additionally, the constant support should be designed so that load adjustments can be made with-out use of special tools and not have an impact on the travel capabilities of the supports.
- (k) Constant Supports shall be furnished with travel stops which shall prevent upward and downward movement of the hanger. The travel stops will be factory installed so that the hanger level is at the "cold" position. The travel stops will be of such design as to permit future re-engagement, even in the event the lever is at a position other than "cold", without having to make hanger adjustments.
- (l) For non-critical, low temperature systems, where vertical movements up to 2" are anticipated, an approved precompressed Variable Spring design similar to Anvil Fig. B- 268 may be used. Where movements are of a small magnitude, spring hangers similar to Anvil Fig. 82 may be used.
- (m) Each Variable Spring shall be individually calibrated at the factory and furnished with travel stops. Spring coils must be square to within 1" to insure proper alignment. Each spring coil must be purchased with a C.M.T.R. and be of domestic manufacture.
- (n) All rigid rod hangers shall provide a means of vertical adjustment after erection.
- (o) Where the piping system is subject to shock loads, such as seismic disturbances or thrusts imposed by the actuation of safety valves, hanger design shall include provisions for rigid restraints or shock absorbing devices of approved design, such as Anvil Fig. 200 shock and sway suppressor, or equal.

Straps
Pipe Supports
Trapeze
Pipe Shields & Saddles
Pipe Roll
Pipe Guides & Slides
Spring Hangers
Constant Supports
Vibration Control & Sway Brace
Sway Strut Assembly
Snubbers
Special Design Products
Application Examples
Master Format 3 Part Specs.
Technical Data
Index

PIPE HANGER SPECIFICATIONS

- (p) Selection of vibration control devices shall not be part of the standard hanger contract. If vibration is encountered after the piping system is in operation, appropriate vibration control equipment shall be installed.
- (q) Hanger rods shall be subject to tensile loading only (see page 233). At hanger locations where lateral or axial movement is anticipated, suitable linkage shall be provided to permit swing.
- (r) Where horizontal piping movements are greater than $\frac{1}{2}$ " and where the hanger rod angularly from the vertical is less than or equal to 4 degrees from the cold to hot position of the pipe, the hanger pipe and structural attachments shall be offset in such manner that the rod is vertical in the hot position. When the hanger rod angularity is greater than 4 degrees from vertical, then structural attachment will be offset so that at no point with the rod angularity exceed 4 degrees from vertical.
- (t) Hangers shall be spaced in accordance with Table 1 and Table 2 on page 225.
- (u) Where practical, riser piping shall be supported independently of the connected horizontal piping. Pipe support attachments to the riser piping shall be riser clamp lugs. Welded attachments shall be of material comparable to that of the pipe, and designed in accordance with governing codes.
- (v) Supports, guides, and anchors shall be so designed that excessive heat will not be transmitted to the building steel. The temperature of supporting parts shall be based on a temperature gradient of 100F° per inch distance from the outside surface of the pipe.
- (w) Hanger components shall not be used for purposes other than for which they were designed. They shall not be used for rigging and erection purposes.
- (x) Hydraulic Snubbers - The hydraulic units shall have a temperature stable control valve. The valve shall provide a locking and bleed rate velocity that provides for tamper proof settings. The fluid level indicator for exact reading of reservoir fluid level in any snubber orientation.

The valve device shall offer a minimum amount of resistance to thermal movement. Any shock force shall cause the suppressor valve to close. With the suppressor valve closed the fluid flow shall essentially stop, thereby causing the unit to resist and absorb the disturbing forces. After the disturbing forces subside, the suppressor valve shall open again to allow free thermal movement of the

piping. The suppressor shall have a means of regulating the amount of movement under shock conditions up to the design load for faulted conditions without release of fluid. The suppressor design shall include a fluid bleed system to assure continued free thermal movement after the shock force subsides. The suppressor shall have a hard surfaced, corrosion resistant piston rod supported by a rod bushings and shall be designed so that it is capable of exerting the required force in tension and compression, utilizing the distance.

- (y) Paint - Variable Spring and Constant Support units will be furnished painted with Stewart Bros. Green Semi-Gloss Primer (#12979B). All other material will receive one shop coat of a red chromate primer meeting the requirements of Federal Specification TT-P-636.

For corrosive conditions hangers will be galvanized or painted with carbo-zinc #11.

- (z) All threads are UNC unless otherwise specified.

Hanger Design Service

Hanger for piping $2\frac{1}{2}$ " and larger, and all spring support for assemblies, shall be completely engineered.

- (a) Engineered hanger assemblies shall be detailed on $8\frac{1}{2}$ " x 11" sheets.

Each sketch will include a location plan showing the location of the hanger in relation to columns of equipment.

Each sketch will include an exact bill of material for the component parts making up each assembly.

- (b) Each engineered hanger assembly will be individually bundled and tagged as far as practical, ready for installation.

Hanger material for piping 2" and smaller shall be shipped as loose material, identified by piping system only. A piping drawing marked with approximate hanger locations and types, and hanger sketches showing typical support arrangements will be furnished.

- (c) Hanger inspections shall be performed in accordance with MSS-SP-89 (Section 7.7), ASME B31.1 (Appendix V), and ASME Section III Subsection NF (NF-5000).

Section 15060

Hangers and Supports

PART 1 GENERAL

- 1.1 SECTION INCLUDES
 - A. Hangers and supports for mechanical piping, ducting and equipment.
- 1.2 RELATED SECTIONS
 - A. Division 3 Section: Cast-in-Place Concrete.
 - B. Division 5 Section: Structural Steel.
 - C. Division 5 Section: Metal Fabrications.
- 1.3 REFERENCES
 - A. American Society of Mechanical Engineers (ASME):
 1. B31.1 - Power Piping (SI Edition).
 2. B31.3 - Chemical Plant and Petroleum Refinery Piping.
 3. B31.9 - Building Services Piping.
 - B. ASTM International (ASTM):
 1. A36 - Standard Specification for Carbon Structural Steel.
 2. A47 - Standard Specification for Ferritic Malleable Iron Castings.
 3. A48 - Standard Specification for Gray Iron Castings.
 4. A53 - Standard Specification for Pipe, Steel, Black and Hot-Dipped, Zinc-Coated, Welded and Seamless.
 5. A123 - Standard Specification for Zinc (Hot-Dip Galvanized) Coatings on Iron and Steel Products.
 6. A240 - Standard Specification for Chromium and Chromium-Nickel Stainless Steel Plate, Sheet, and Strip for Pressure Vessels and for General Applications.
 7. A387 - Standard Specification for Pressure Vessel Plates, Alloy Steel, Chromium-Molybdenum.
 8. A515 - Standard Specification for Pressure Vessel Plates, Carbon Steel, for Intermediate-and Higher-Temperature Service.
 9. A536 - Standard Specification for Ductile Iron Castings.
 10. A575 - Standard Specification for Steel Bars, Carbon, Merchant Quality, M-Grades.
 11. A668 - Standard Specification for Steel Forgings, Carbon and Alloy, for General Industrial Use.
 12. A1011 - Standard Specification for Steel, Sheet and Strip, Hot-Rolled, Carbon, Structural, High-Strength Low-Alloy and High-Strength Low-Alloy with Improved Formability.
 13. B633 - Standard Specification for Electrodeposited Coatings of Zinc on Iron and Steel.
 - C. Manufacturers Standardization Society of The Valve and Fittings Industry (MSS) Standard Practices:
 1. SP-58 Pipe Hangers and Supports - Materials, Design and Manufacture.
 2. SP-69 Pipe Hangers and Supports - Selection and Application.
 3. SP-77 Guidelines for Pipe Support Contractual Relationships.
 4. SP-89 Pipe Hangers and Supports - Fabrication and Installation Practices.
 5. SP-90 Guidelines on Terminology for Pipe Hangers and Supports.
 6. SP-127 Bracing for Piping Systems Seismic-Wind-Dynamic Design, Selection, Application.
- 1.4 SYSTEM DESCRIPTION
 - A. Contractor General Requirements:
 1. Incorporate in construction pipe hangers and supports to manufacturer's recommendations utilizing manufacturer's regular production components, parts and assemblies.
 2. Comply with maximum load ratings with consideration for allowable stresses prescribed by ASME B31.1 or MSS SP-58.
 3. Provide supports, guides and anchors that do not transmit unacceptable heat and vibration to building structure.
 4. The selection of pipe hangers and supports shall be based upon the overall design concept of the piping systems and any special requirements, which may be called for in the specifications. The support systems shall provide for, and control, the free or intended movement of the piping including its movement in relation to that of connected equipment. (Extracted from ANSI/MSS-SP69, 2003, Page 1, Section 4.2, with permission of the publisher, the Manufacturers Standardization Society.)
 5. Provide for vertical adjustments after installation of supported material and during commissioning, where feasible, to ensure pipe is at design elevation and slope.
 - B. Selection of Hangers and Supports for Pipe Movement:
 1. Select hangers and supports to perform under all conditions of operation, allowing free expansion and contraction, and to prevent excessive stresses being introduced into piping system and connected equipment.
 2. Angularity of rod hanger resulting from horizontal movement of the piping system from cold to hot positions shall not to exceed 4 degrees from vertical.
 3. Where horizontal pipe movement is greater than 1/2 inch (12.7 mm), offset pipe hanger and support so that rod hanger is vertical in hot position.
 4. Where significant vertical movement of the pipe occurs at the hanger location, a resilient support must be used. Selection of

Straps

Pipe Supports

Trapeze

Pipe Shields & Saddles

Pipe Roll

Pipe Guides & Slides

Spring Hangers

Constant Supports

Vibration Control & Sway Brace

Sway Strut Assembly

Snubbers

Special Design Products

Application Examples

Master Format 3 Part Specs.

Technical Data

Index

Section 15060

Hangers and Supports

resilient supports shall be based on permissible load variation and effects on adjacent equipment. Support selection for typical load variations are shown in Table 2 of MSS-SP-69. Load and movement calculations shall be made for the proper selection of spring hangers. Vertical movement and load transfer from riser expansion to horizontal runs shall be given consideration when applying spring hangers. Spring Cushion Hangers may be used where vertical movement does not exceed 1/4 inch (6 mm), and where formal load and movement calculations are not required. Variable Spring Hangers shall be used for all other resilient support requirements. Constant Support Hangers shall be used on piping systems where the deviation in supporting force must be limited to 6 percent and which cannot be accommodated by a Variable Spring Hanger. (Extracted from ANSI/MSS-SP69, 2003, Page 7, Section 7.4 and 7.4.1 to 7.4.3, inclusive, with permission of the publisher, the Manufacturers Standardization Society.)

- C. Hanger Spacing: (Extracted from ANSI/MSS-SP69, 2003, Page 8, Table 3, with permission of the publisher, the Manufacturers Standardization Society.)

TABLE 3 – Maximum Horizontal Pipe Hanger and Support Spacing

Nominal Pipe or Tube Size	1				2				3				4				5		6		7		8		9		10	
	Std Wt Steel Pipe								Copper Tube								Fire Protection	Ductile Iron Pipe	Cast Iron Soil	Glass	Plastic	Fiberglass Reinforced						
	Water Service				Vapor Service				Water Service				Vapor Service															
in. mm	ft.	m	ft.	m	ft.	m	ft.	m	ft.	m	ft.	m	ft.	m														
1/4 (6)	–	–	–	–	5	1.5	5	1.5	Follow requirements of the National Fire Protection Association See Section 14.	20 ft. (6.1 m) max spacing; min of one (1) hanger per pipe section close to the joint behind the bell and at change of direction and branch connections. For pipe sizes six (6) inches (150 mm) and under, installed on ASME B31 projects, that are subjected to loadings other than weight of pipe and contents, the span should be limited to the maximum spacing for water service steel pipe.	10 ft. (3.0 m) max spacing; min of one (1) hanger per pipe section close to joint on the barrel also at change of direction and branch connections	8 ft. (2.4 m) max spacing; follow pipe manufacturer's recommendations See Section 17.	Follow pipe manufacturer's recommendations for material and service condition. See Section 18.	Follow pipe manufacturer's recommendations for material and service condition. See Section 19.														
3/8 (10)	7	2.1	8	2.4	5	1.5	6	1.8																				
1/2 (15)	7	2.1	8	2.4	5	1.5	6	1.8																				
3/4 (20)	7	2.1	9	2.7	5	1.5	7	2.1																				
1 (25)	7	2.1	9	2.7	6	1.8	8	2.4																				
1 1/4 (32)	7	2.1	9	2.7	7	2.1	9	2.7																				
1 1/2 (40)	9	2.7	12	3.7	8	2.4	10	3.0																				
2 (50)	10	3.0	13	4.0	8	2.4	11	3.4																				
2 1/2 (65)	11	3.4	14	4.3	9	2.7	13	4.0																				
3 (80)	12	3.7	15	4.6	10	3.0	14	4.3																				
3 1/2 (90)	13	4.0	16	4.9	11	3.4	15	4.6																				
4 (100)	14	4.3	17	5.2	12	3.7	16	4.9																				
5 (125)	16	4.9	19	5.8	13	4.0	18	5.5																				
6 (150)	17	5.2	21	6.4	14	4.3	20	6.1																				
8 (200)	19	5.8	24	7.3	16	4.9	23	7.0																				
10 (250)	22	6.7	26	7.9	18	5.5	25	7.6																				
12 (300)	23	7.0	30	9.1	19	5.8	28	8.5																				
14 (350)	25	7.6	32	9.8	–	–	–	–																				
16 (400)	27	8.2	35	10.7	–	–	–	–																				
18 (450)	28	8.5	37	11.3	–	–	–	–																				
20 (500)	30	9.1	39	11.9	–	–	–	–																				
24 (600)	32	9.8	42	12.8	–	–	–	–																				
30 (750)	33	10.1	44	13.4	–	–	–	–																				

- Notes: (1) For spacing supports incorporating type 40 shields, see table 5.
 (2) Does not apply where span calculations are made or where there are concentrated loads between supports such as flanges, valves, specialties, etc. or changes in direction requiring additional supports.
 (3) Unbalanced forces of hydrostatic or hydrodynamic origin (thrust forces) unless restrained externally can result in pipe movement and separation of joints if the joints of the system are not of a restrained joint design. See Section 13.3.

D. Pipe Attachments for Insulated Lines:

- The connections to pipe attachments shall be outside the insulation so that movement of the line shall not cause damage to the insulation. Insulation protection shields shall be provided to protect the vapor barrier of the insulation on cold lines. Under no circumstances shall hangers, supports or guides be applied directly to horizontal pipe or tubing on vapor barrier lines. For cryogenic piping systems, shields incorporating rigid, high-density polyurethane foam inserts or other load bearing insulation should be used. The support should include means for maintaining vapor barrier integrity. Because of the temperature/compressive strength relationship of polyurethane foam, the recommended shield designs must be selected to accommodate loading conditions at both the installation and operating temperature. (Extracted from ANSI/MSS-SP69, 2003, Page 10, Section 10 and 10.1 to 10.3, inclusive, with permission of the publisher, the Manufacturers Standardization Society.)
- Deviation to the above is permissible when the Anvil Fig 260 ISS (Insulation Saddle System) is used when proper insulating techniques are employed including the use of mastic and caulk on all insulation edges, and final taping.

Section 15060

Hangers and Supports

- E. Recommended Minimum Rod Diameters for Single Rigid Rod Hangers: (Extracted from ANSI/MSS-SP69, 2003, Page 9, Table 4, with permission of the publisher, the Manufacturers Standardization Society.)

TABLE 4 – Recommended Min. Rod Diameter for Single Rigid Rod Hangers⁽¹⁾⁽²⁾

Nominal Pipe or Tubing Size		Columns ⁽³⁾ 1, 2, 6, 7		Columns ⁽³⁾ 3, 4, 8, 9, 10	
		Nominal Rod Diameter		Nominal Rod Diameter	
<i>in.</i>	<i>mm</i>	<i>ft.</i>	<i>m</i>	<i>ft.</i>	<i>m</i>
¼	(6)	–	–	¾	M10
⅜	(10)	¾	M10	¾	M10
½	(15)	¾	M10	¾	M10
¾	(20)	¾	M10	¾	M10
1	(25)	¾	M10	¾	M10
1¼	(32)	¾	M10	¾	M10
1½	(40)	¾	M10	¾	M10
2	(50)	¾	M10	¾	M10
2½	(65)	½	M12	½	M12
3	(80)	½	M12	½	M12
3½	(90)	½	M12	½	M12
4	(100)	⅝	M16	½	M12
5	(125)	⅝	M16	½	M12
6	(150)	¾	M20	⅝	M16
8	(200)	¾	M20	¾	M20
10	(250)	⅞	M20	¾	M20
12	(300)	⅞	M20	¾	M20
14	(350)	1	M24	–	–
16	(400)	1	M24	–	–
18	(450)	1	M24	–	–
20	(500)	1¼	M30	–	–
24	(600)	1¼	M30	–	–
30	(750)	1¼	M30	–	–

1. (1) For calculated loads, rod diameters may be sized in accordance with MSS SP-58, Table 3 provided Table 1 and Section 73 of MSS SP-58 are satisfied.
 2. (2) Rods may be reduced one size for double rod hangers. Minimum rod diameter shall be 3/8 inch (9.5 mm) (M10).
 3. (3) Columns noted refer to Table 3.
- F. Anchors Guides and Restraints:
1. Anchors, guides and restraints shall be located by the Engineer responsible for piping design. Should the need or the desirability of relocating, eliminating or adding anchors, guides or restraints arise; such changes shall be brought to the attention of the Engineer for consideration and approval.
 2. Anchors, guides and restraints shall be designed for imposed loadings as determined by the Engineer. For guided systems, in the absence of specified lateral loads, the guide shall be designed for 20 percent of the dead weight load based on the spans listed in Table 3, with a design load of 50 lb (0.22 kN) as a minimum.
 3. For pressure piping with joints not having a restraining design, other positive restraining means such as clamps, rods and/or thrust blocking shall be used to maintain the integrity of the joints.
 4. The necessity for, and the location of, shock suppressors and seismic control devices shall be as determined by the Engineer responsible for piping design.
 5. The location, type and number of corrective devices which may be necessary to control any unforeseen vibrations, as determined after the piping is in service, are not a part of this standard.
 6. Refer to MSS SP-127 for the design, selection, and application of the bracing piping systems subject to seismic - wind - dynamic loading.
 7. (Extracted from ANSI/MSS-SP69, 2003, Page 11, Section 13 and 13.1 to 10.6, inclusive, with permission of the publisher, the Manufacturers Standardization Society.)
- 1.5 SUBMITTALS
- A. Submit under provisions of Section 01 30 00.
 - B. Product Data: Manufacturer's data sheets on each product to be used, including:
 1. Preparation instructions and recommendations.

Section 15060

Hangers and Supports

2. Load capacity and sizing schedules specific to Project.
3. Installation methods.
- C. Certifications:
 1. Product certificates signed by manufacturer certifying materials comply with specified performance characteristics and criteria and physical requirements. Certificates shall be furnished only as required by specific codes, upon request.
- D. Shop Drawings:
 1. Bases, hangers and supports.
 2. Connections to equipment and structure.
 3. Structural assemblies.
- E. Selection Samples: For each finish product specified, two complete sets of color chips representing manufacturer's full range of available colors and patterns.
- F. Verification Samples: For each finish product specified, two samples, minimum size 6 inches (150 mm) square, representing actual product, color, and patterns.
- G. Closeout Submittals:
 1. Warranty: Warranty documents.
 2. Operation and Maintenance Data: Operation and maintenance data for installed products in accordance with Division 1 Closeout Submittals (Maintenance Data and Operation Data) Section. Include methods for maintaining installed products, and precautions against cleaning materials and methods detrimental to finishes and performance.
- 1.6 QUALITY ASSURANCE
 - A. Manufacturer Qualifications:
 1. Manufacturing facilities shall be registered to ISO 9001.2000 and assessed to ISO 9000.2000 standard. A copy of the current certificate shall be available upon request.
 - B. Installer Qualifications:
 1. Utilize an installer experienced in performing work of this section who is experienced in installation of work similar to that required for this project and per the minimum requirements of MSS SP-89.
 - C. Conduct pre-installation meeting to verify project requirements, coordinate with other trades, and establish condition and completeness of substrate. Review manufacturer's installation instructions and manufacturer's warranty requirements.
- 1.7 DELIVERY, STORAGE, AND HANDLING
 - A. Store products in manufacturer's unopened packaging until ready for installation.
 - B. Store and dispose of solvent-based materials, and materials used with solvent-based materials, in accordance with requirements of local authorities having jurisdiction.
- 1.8 PROJECT CONDITIONS
 - A. Maintain environmental conditions (temperature, humidity, and ventilation) within limits recommended by manufacturer for optimum results. Do not install products under environmental conditions outside manufacturer's absolute limits.
- 1.9 WARRANTY
 - A. Manufacturer's Warranty: Submit, for Owner's acceptance, manufacturer's standard warranty document executed by authorized company official. Manufacturer's warranty is in addition to, and not a limitation of, other rights, Owner may have under Contract Documents.

PART 2 PRODUCTS

- 2.1 MANUFACTURERS
 - A. Acceptable Manufacturer: Anvil Intl., Inc.; 110 Corporate Dr. Suite 10, Portsmouth, NH 03802. ASD. Tel: (603) 422-8000. Fax: (603) 422-8033. Web: <http://www.anvilintl.com>.
 - B. Substitutions: Not permitted.
 - C. Requests for substitutions will be considered in accordance with provisions of Section 01 60 00.
- 2.2 MANUFACTURED UNITS - APPLICATION REQUIREMENTS
 - A. Fabricate hangers, supports and sway braces to comply with building codes.
 - B. Do not use installed hangers for rigging or erection purposes.
 - C. Materials available by product type. Provide materials to comply with location and application requirements unless noted otherwise on drawings and schedules.
 1. Pipe rings - Malleable iron, carbon steel.

Section 15060

Hangers and Supports

2. Clevis - Carbon steel.
 3. Steel pipe clamps - Carbon steel, alloy, stainless steel.
 4. Socket clamps - Carbon steel.
 5. Beam clamps - Malleable/ductile iron, hardened steel, carbon steel, forged steel.
 6. Structural attachments - Carbon steel, malleable iron.
 7. Ceiling plates/ceiling flanges - Plastic, cast iron, malleable iron.
 8. Concrete inserts and attachments – Malleable iron, carbon steel; stainless steel body, fiberglass bars, polypropylene disc (iron cross design).
 9. Rod attachments - Carbon steel, malleable iron, forged steel.
 10. Pipe supports - Carbon steel, cast iron.
 11. Pipe shields and saddles - Carbon steel, alloy steel, stainless steel.
 12. Pipe rolls - Cast iron, carbon steel.
 13. Guides - Carbon steel; slides, carbon steel with PTFE slide plates.
 14. Engineered hangers - Carbon steel, stainless steel, chrome molybdenum steel.
- D. Finishes: Provide finishes to comply with location and application requirements unless noted otherwise on drawings and schedules.
1. Electro-plating galvanizing process per ASTM B633.
 2. Hot Dipped galvanizing process per ASTM A153.
 3. Epoxy paint.
 4. Zinc-rich paint.
 5. Standard primer shall meet Fed Spec TT-P-636.
- E. Application Requirements: Use components for intended service conditions only. Comply with service requirements below unless noted otherwise on drawings and schedules.
1. Steel hangers in contact with copper piping shall be copper plated, copper painted or epoxy coated.
 2. Exterior utility and mechanical yard areas shall use piping that is hot dip galvanized.
 3. Interior piping to be black iron.
 4. Hydronics and plumbing piping hangers shall be manufactured from carbon steel, cast malleable iron or cast iron.
 5. Steam piping hangers shall be manufactured from Chrome Molybdenum steel.
 6. Submerged piping hangers shall be manufactured from 316 stainless steel.
- 2.3 MANUFACTURED UNITS - MSS-SP-69 TYPES NOTED FOR PRODUCTS THAT ARE IN COMPLIANCE
- A. Copper Tubing Hangers: Fig. Numbers.
1. CT65 Light Weight Adjustable Clevis.
 2. CT69 Adjustable Swivel Ring, MSS-SP-69 (Type 10).
 3. CT109 Split Tubing Ring (Ring Only), MSS-SP-69 (Type 11).
 4. CT121 Copper Tubing Riser Clamp, MSS-SP-69 (Type 8).
 5. CT121C Copper Tubing Riser Clamp.
 6. CT128R Rod Threaded Ceiling Flange.
 7. CT138R Extension Split Tubing Clamp (Rod Threaded), MSS-SP-69 (Type 12).
 8. CT255 Copper Tubing Alignment Guide.
- B. Pipe Rings: Fig. Numbers.
1. 67 Pipe or Conduit Hanger, MSS-SP-69 (Type 5).
 2. 69 Adjustable Swivel Ring, Tapped per NFPA Standards, MSS-SP-69 (Type 10).
 3. 104 Adjustable Swivel Ring, Split Ring Type, MSS-SP-69 (Type 6).
 4. 108 Split Pipe Ring, MSS-SP-69 (Type 11).
 5. 138R Extension Split Pipe Clamp (Rod Threaded), MSS-SP-69 (Type 12).
- C. Clevis: Fig. Numbers.
1. 65 Light Duty Adjustable Clevis.
 2. 67 Pipe or Conduit Hanger, MSS-SP-69 (Type 5).
 3. 260 ISS (Insulation Saddle System) for support of insulated pipe operating between -40 degrees F to 200 degrees F. See section 2.3.P11 for additional information.
 4. 260 Adjustable Clevis Hanger, MSS-SP-69 (Type 1).
 5. 300 Adjustable Clevis for Insulated Lines, MSS-SP-69 (Type 1).
 6. 590 Adjustable Clevis for Ductile or Cast Iron Pipe, MSS-SP-69 (Type 1).
- D. Steel Pipe Clamps: Fig. Numbers.
1. 40 Riser Clamp - Standard, MSS-SP-69 (Type 42).
 2. 100 Extended Pipe Clamp.
 3. 103 Offset Pipe Clamp.

Section 15060

Hangers and Supports

4. 212 Medium Pipe Clamp, MSS-SP-69 (Type 4).
 5. 212FP Earthquake Bracing Clamp, MSS-SP-69 (Type 4).
 6. 216 Heavy Pipe Clamp, MSS-SP-69 (Type 4).
 7. 224 Alloy Steel Pipe Clamp, MSS-SP-69 (Type 2).
 8. 246 Heavy Duty Alloy Steel Pipe Clamp, MSS-SP-69 (Type 2).
 9. 261 Extension Pipe or Riser Clamp, MSS-SP-69 (Type 8).
 10. 295 Double Bolt Pipe Clamp, MSS-SP-69 (Type 3).
 11. 295A Alloy Double Bolt Pipe Clamp, MSS-SP-69 (Type 3).
 12. 295H Heavy Duty Double Bolt Pipe Clamp, MSS-SP-69 (Type 3).
- E. Steel Riser Clamps: Fig. Numbers.
1. 40 Riser Clamp - Standard, MSS-SP-69 (Type 42).
 2. 261 Extension Pipe or Riser Clamp, MSS-SP-69 (Type 8).
- F. Socket Clamps (AWWA/Ductile/Cast Iron Pipe Sizes Only): Fig. Numbers.
1. 594 Socket Clamp Washer.
 2. 595 Socket Clamp for Ductile Iron or Cast Iron Pipe, MSS-SP-69 (Type 8).
 3. 599 Socket Clamp Washer.
 4. 600 Socket Clamp for Ductile Iron or Cast Iron Pipe, MSS-SP-69 (Type 8).
- G. Beam Clamps: Fig. Numbers.
1. 14 Adjustable Side Beam Clamp, MSS-SP-69 (Type 27).
 2. 86 C-Clamp with Set Screw & Lock Nut, MSS-SP-69 (Type 23).
 3. 87 C-Clamp with Set Screw & Fig. 89 Retaining Clip, MSS-SP-69 (Type 23).
 4. 88 C-Clamp with Set Screw Only, MSS-SP-69 (Type 23).
 5. 89 Retaining Clip.
 6. 89X Retaining Clip.
 7. 92 Universal C-type Clamp (Standard Throat), MSS-SP-69 (Type 19 and 23).
 8. 93 Universal C-type Clamp (Wide Throat), MSS-SP-69 (Type 19 and 23).
 9. 94 Wide Throat Top Beam C-Clamp, MSS-SP-69 (Type 19).
 10. 95 C-Clamp with Locknut, MSS-SP-69 (Type 23).
 11. 133 Standard Duty Beam Clamp, MSS-SP-69 (Type 21).
 12. 134 Heavy Duty Beam Clamp, MSS-SP-69 (Type 21).
 13. 217 Adjustable Side Beam Clamp, MSS-SP-69 (Type 25).
 14. 218 Malleable Beam Clamp without Extension Piece, MSS-SP-69 (Type 30).
 15. 227 Top Beam Clamp, MSS-SP-69 (Type 25).
 16. 228 Universal Forged Steel (UFS) Beam Clamp, MSS-SP-69 (Type 28 and 29).
 17. 292 Beam Clamp Right Hand Thread with Weld less Eye Nut, MSS-SP-69 (Type 28 and 29).
 18. 292L Beam Clamp Left Hand Thread with Weld less Eye Nut, MSS-SP-69 (Type 28 and 29).
- H. Structural Attachments: Fig. Numbers.
1. 54 Two Hole Welding Beam Lug.
 2. 55 Structural Welding Lug (Short), MSS-SP-69 (Type 57).
 3. 55L Structural Welding Lug (Long), MSS-SP-69 (Type 57).
 4. 60 Steel Washer Plate.
 5. 66 Welded Beam Attachment, MSS-SP-69 (Type 22).
 6. 112 Brace Fitting Complete.
 7. 113 Brace Fitting (Pipe End Only).
- I. Ceiling Plates and Ceiling Flanges: Fig. Numbers.
1. 127 Plastic Ceiling Plate.
 2. 128 Pipe Threaded, Ceiling Flange.
 3. 128R Rod Threaded, Ceiling Flange.
 4. 153 Pipe Hanger Flange.
 5. 395 Cast Iron Ceiling Plate.
- J. Brackets: Fig. Numbers.
1. 194 Light Welded Steel Bracket, MSS-SP-69 (Type 31).
 2. 195 Medium Welded Steel Bracket, MSS-SP-69 (Type 32).
 3. 199 Heavy Welded Steel Bracket, MSS-SP-69 (Type 33).
 4. 202 Iron Side Beam Bracket, MSS-SP-69 (Type 34).
 5. 206 Steel Side Beam Bracket, MSS-SP-69 (Type 34).

Section 15060

Hangers and Supports

6. 207 Threaded Steel Side Beam Bracket, MSS-SP-69 (Type 34).
- K. Concrete Inserts and Attachments: Fig. Numbers.
 1. 47 Concrete Single Lug Plate.
 2. 49 Concrete Clevis Plate.
 3. 52 Concrete Rod Attachment Plate.
 4. 152 Screw Concrete Insert.
 5. 281 Wedge Type Concrete Insert, MSS-SP-69 (Type 18).
 6. 282 Universal Concrete Insert, MSS-SP-69 (Type 18).
 7. 285 Light Weight Concrete Insert, MSS-SP-69 (Type 19).
 8. 286 Iron Cross Design, MSS-SP-69 (Type 18).
- L. Hanger Rod and Rod Attachments: Fig. Numbers.
 1. 110R Socket, Rod Threaded, MSS-SP-69 (Type 16).
 2. 114 Turnbuckle Adjuster, MSS-SP-69 (Type 15).
 3. 135 Straight Rod Coupling (With Sight-Hole).
 4. 135E Straight Rod Coupling (Less Sight-Hole).
 5. 135R Straight Rod Coupling (Reducing).
 6. 136 Straight Rod Coupling, MSS-SP-69 (Type 40).
 7. 136R Straight Rod Coupling (Reducing).
 8. 140 Machine Threaded Rod. Threaded both ends with right-hand threads.
 9. 142 Machine Threaded Coach Screw Rod. Plain finish.
 10. 146 Continuous Machine Threaded Rods.
 11. 148 Machine Threaded Rod with Eye End.
 12. 157 Extension piece.
 13. 230 Turnbuckle, MSS-SP-69 (Type 13).
 14. 233 Turnbuckle, MSS-SP-69 (Type 13).
 15. 248 Machine Threaded Rod with Eye End. Right-hand threads with un-welded eye.
 16. 248L Machine Threaded Rod with Eye End. Left-hand threads with un-welded eye.
 17. 248X Machine Threaded Rod with Linked Eye Ends. Un-welded eye.
 18. 253 Machine Threaded Rod. Threaded both ends with right-hand and left-hand threads.
 19. 278 Machine Threaded Rod with Eye End. Right-hand threads with welded eye.
 20. 278L Machine Threaded Rod with Eye End. Left-hand threads with welded eye.
 21. 278X Machine Threaded Rod with Linked Eye Ends. Welded eye.
 22. 290 Thread Weld less Eye Nut (Right Hand Threads), MSS-SP-69 (Type 17).
 23. 290L Thread Weld less Eye Nut (Left Hand Threads), MSS-SP-69 (Type 17).
 24. 299 Forged Steel Clevis, MSS-SP-69 (Type 14).
- M. U-Bolts and Straps: Fig. Numbers.
 1. 120 Light Weight U-Bolt.
 2. 126 One-Hole Clamp.
 3. 137 Standard U-Bolts, MSS-SP-69 (Type 24).
 4. 137C Plastic Coated U-Bolts, MSS-SP-69 (Type 24).
 5. 137S Special U-Bolts (Non-Standard).
 6. 243 Pipe Strap.
 7. 244 Pipe Strap.
 8. 262 Strap Short, MSS-SP-69 (Type 26).
 9. 291 Clevis Pin with Cotters.
- N. Pipe Supports: Fig. Numbers.
 1. 62 Pipe Stanchion, Type A, B and C.
 2. 63 Pipe Stanchion, Type A, B and C.
 3. 191 Pipe Stanchion Saddle With U-Bolt, MSS-SP-69 (Type 37).
 4. 192 Adjustable Pipe Saddle Support, MSS-SP-69 (Type 38).
 5. 258 Pipe Saddle Support, MSS-SP-69 (Type 36).
 6. 259 Pipe Stanchion Saddle Support, MSS-SP-69 (Type 37).
 7. 264 Adjustable Pipe Saddle Support, MSS-SP-69 (Type 38).
 8. 265 Adjustable Pipe Saddle Support with U-Bolt, MSS-SP-69 (Type 38).
- O. Trapeze and Channel Support: Fig. Numbers.
 1. 45 Channel Assembly.

Straps
Pipe Supports
Trapeze
Pipe Shields & Saddles
Pipe Roll
Pipe Guides & Slides
Spring Hangers
Constant Supports
Vibration Control & Sway Brace
Sway Strut Assembly
Snubbers
Special Design Products
Application Examples
Master Format 3 Part Specs.
Technical Data
Index

Section 15060

Hangers and Supports

2. 46 Universal Trapeze Assembly.
 3. 50 Equal Leg Angle for Trapeze Assembly.
- P. Pipe Shields and Saddles: Fig. Numbers.
1. 160 Pipe Covering Protection Saddle, MSS-SP-69 (Type 39A and 39B).
 2. 161 Pipe Covering Protection Saddle, MSS-SP-69 (Type 39A and 39B).
 3. 162 Pipe Covering Protection Saddle, MSS-SP-69 (Type 39A and 39B).
 4. 163 Pipe Covering Protection Saddle, MSS-SP-69 (Type 39A and 39B).
 5. 164 Pipe Covering Protection Saddle, MSS-SP-69 (Type 39A and 39B).
 6. 165 Pipe Covering Protection Saddle, MSS-SP-69 (Type 39A and 39B).
 7. 165A Pipe Covering Protection Saddle (Alloy), MSS-SP-69 (Type 39A and 39B).
 8. 166A Pipe Covering Protection Saddle (Alloy), MSS-SP-69 (Type 39A and 39B).
 9. 167 Insulation Protection Shield, MSS-SP-69 (Type 40).
 10. 168 Rib-Lok Shield, MSS-SP-69 (Type 40).
 11. 260 (ISS) Insulation Saddle System, Clevis with High Impact Glass Reinforced Poly-Propylene Saddle.
- Q. Pipe Rolls: Fig. Numbers.
1. 171 Single Pipe Roll, MSS-SP-69 (Type 41).
 2. 175 Roller Chair, MSS-SP-69 (Type 44).
 3. 177 Adjustable Pipe Roll Support, MSS-SP-69 (Type 41).
 4. 178 Spring Cushion Hanger, MSS-SP-69 (Type 49).
 5. 181 Adjustable Steel Yoke Pipe Roll, MSS-SP-69 (Type 43).
 6. 271 Complete Pipe Roll Stand, MSS-SP-69 (Type 44).
 7. 274 Adjustable Pipe Roll Stand With Base Plate, MSS-SP-69 (Type 46).
 8. 274P Adjustable Pipe Roll Stand, Base Plate Only.
 9. 275 Adjustable Pipe Roll Stand Without Base Plate.
 10. 277 Pipe Roll and Base Plate with Cast Iron Base Plate, MSS-SP-69 (Type 45).
 11. 277S Pipe Roll and Base Plate with Steel Base Plate.
- R. Guides and Slides: Fig. Numbers.
1. 212 Medium Pipe Clamp, use with slide assemblies.
 2. 255 Pipe Alignment Guide, Single Clamp (MVT 4-8 in.)
 3. 256 Pipe Alignment Guide, Double Clamp (MVT 6-10 in.)
 4. 257 Pipe Slides Assembly, Structural Tee Slide Assembly, MSS-SP-69 (Type 35).
 5. 257A Pipe Slides Assembly, Structural Tee.
 6. 432 Special Clamp, use with slide assemblies.
 7. 436 Pipe Slides Assembly, Fabricated Tee Slide Assembly, MSS-SP-69 (Type 35).
 8. 436A Pipe Slides Assembly, Fabricated Tee.
 9. 439 Structural "H" Slide Assembly, Complete, MSS-SP-69 (Type 35).
 10. 439A "H" Section Only.
- 2.4 METAL FRAMING
- A. Provide metal framing channel, fittings and hardware components as indicated or required for the structural support of piping systems and equipment.
1. Metal framing shall be Anvil Strut as manufactured by Anvil International.
 2. Accessories: As indicated or required by application and location.
 - a. Strut mounted pipe support, Klo-Shure insulated couplings with strut clamp, size range of 3/8 inch (9.5 mm) through 4 inch (102 mm) copper tube with 3/8 inch (9.5 mm) through 1 inch (25 mm) thick insulation.
 - b. Strut mounted pipe clamps.
 - c. Strut mounted pipe rollers.
 - d. Strut mounted Cushion Clamps (steel pipe and copper tube).
- B. Materials Available: Provide materials and finishes to comply with locations and applications requirements as noted on drawings or schedules.
1. Channels shall be produced from prime structural metals complying with the following specification as applicable:
 - a. Pre-Galvanized Steel - ASTM A653.
 - b. Plain Steel - ASTM A570.
 - 1) Finish: Hot-dip galvanized.
 - 2) Finish: Supr-Green powder coating.
 - 3) Finish: PVC coated.
 - c. Aluminum (Type 6063-T6) - ASTM B221.
 - d. Stainless Steel (Type 304 and 316) - ASTM A240.

Section 15060

Hangers and Supports

- 2.5 EQUIPMENT SUPPORTS
 - A. Fabricate equipment supports not provided by equipment manufacturer from structural grade steel meeting requirements of Section 05 12 16 - Fabricated Fireproofed Steel Columns.
- 2.6 EQUIPMENT ANCHOR BOLTS AND TEMPLATES
 - A. Provide templates to ensure accurate location of anchor bolts.

PART 3 EXECUTION

- 3.1 EXAMINATION
 - A. Do not begin installation until substrates have been properly prepared.
 - B. If substrate preparation is the responsibility of another installer, notify Architect of unsatisfactory preparation before proceeding.
- 3.2 PREPARATION
 - A. Clean surfaces thoroughly prior to installation.
 - B. Prepare surfaces using the methods recommended by the manufacturer for achieving the best result for the substrate under the project conditions.
- 3.3 HANGER SPACING
 - A. Plumbing Piping: Most stringent requirements of Plumbing Code, or authority having jurisdiction.
 - B. Fire Protection: Comply with applicable fire code.
 - C. Gas and Fuel Oil Piping: Comply with pipe manufacturer's recommendations and applicable codes.
 - D. Copper Piping: Comply with pipe manufacturer's recommendations and applicable codes.
 - E. Flexible System Grooved Pipe: Minimum of one hanger required per the minimum recommended pipe length. Comply with groove manufacturer's recommended average hangers per pipe length.
 - F. When practical located immediately adjacent to any change of direction of pipe. Total length of pipe between supports less than three-fourths the full hanger span.
 - G. In case of concentrated loads (such as valves) the supports shall be placed as close as possible.
- 3.4 HANGER INSTALLATION
 - A. Install in accordance with manufacturer's instructions.
 - B. Clamps on Riser Piping:
 - 1. Support independent of connected horizontal pipework using riser clamps and riser clamp lugs welded to riser.
 - 2. Bolt tightening torques shall be to industry standards.
 - 3. Cast Iron Pipes: Install clamp below joint.
 - 4. Steel Pipes: Clamp is fitted preferably below coupling or welded pipe lug.
 - C. Use approved constant support type hangers where:
 - 1. For critical high temperature where vertical movement of pipe work is 1/2 inch (12.7 mm) or more.
 - 2. Transfer of load to adjacent hangers or connected equipment is not permitted.
 - D. Use variable support spring hangers where:
 - 1. Transfer of load to adjacent piping or to connected equipment is not critical.
 - 2. Variation in supporting effect does not exceed 25 percent of total load.
 - E. Adjust hangers to equalize load.
 - F. Support from Structural Members: Where structural bearing does not exist or inserts are not in suitable locations, provide supplementary structural steel members.
 - G. Field welding of supports should be done by qualified welders using qualified welding procedures.
 - H. Proper care and ventilation should be given when welding galvanized components.
- 3.5 HORIZONTAL MOVEMENT
 - A. Angularity of rod hanger resulting from horizontal movement of pipework from cold to hot position not to exceed 4 degrees from vertical.
 - B. Where horizontal pipe movement is greater than 1/2 inch (12.7 mm), offset pipe hanger and support so that rod hanger is vertical in hot position.
- 3.6 FINAL ADJUSTMENT
 - A. Adjust Hangers and Supports:
 - 1. Ensure that rod is vertical under operating conditions.

Straps
Pipe Supports
Trapeze
Pipe Shields & Saddles
Pipe Roll
Pipe Guides & Slides
Spring Hangers
Constant Supports
Vibration Control & Sway Brace
Sway Strut Assembly
Snubbers
Special Design Products
Application Examples
Master Format 3 Part Specs.
Technical Data
Index

Section 15060

Hangers and Supports

- 2. Equalize loads.
- B. Adjustable Clevis:
 - 1. Tighten hanger load nut securely to ensure proper hanger performance.
 - 2. Tighten upper nut after adjustment.
- C. C-Clamps:
 - 1. Follow manufacturer's recommended written instructions and torque values when tightening C-clamps to bottom flange of beam.
- D. Beam Clamps:
 - 1. Tighten all set screws and lock nuts.
 - 2. Hammer jaw firmly against underside of beam for Figure 127 only.
- 3.7 PROTECTION
 - A. Protect installed products until completion of project.
 - B. Touch-up, repair or replace damaged products before Substantial Completion.

END OF SECTION

Pipe Support Spacing

TABLE 1: MAXIMUM HORIZONTAL SPACING BETWEEN PIPE SUPPORTS FOR STANDARD WEIGHT STEEL PIPE*

	Nominal Pipe Size (in)																					
	1/2	3/4	1	1 1/2	2	2 1/2	3	3 1/2	4	5	6	8	10	12	14	16	18	20	24	30		
Max. Span (Ft) Water Service	7	7	7	9	10	11	12	13	14	16	17	19	22	23	25	27	28	30	32	33		
Max. Span (Ft) Vapor Service	8	9	9	12	13	14	15	16	17	19	21	24	26	30	32	35	37	39	42	34		
Recommended Hanger Rod Sizes	3/8				1/2				5/8		3/4		7/8		1		1	1 1/4	1 1/2	1 1/2	or trapeze	

The above spacing and capacities are based on pipe filled with water. Additional valves and fittings increase the load and therefore closer hanger spacing is required.

*Many codes and specifications state "pipe hangers must be spaced every 10ft. regardless of size." This local specification must be followed.

TABLE 2: MAXIMUM HORIZONTAL SPACING BETWEEN COPPER TUBING SUPPORTS

	Nominal Tubing Size (in)									
	1/2	3/4	1	1 1/4	1 1/2	2	2 1/2	3	3 1/2	4
Max. Span (Ft) Water Service	5	5	6	7	8	8	9	10	11	12
Max. Span (Ft) Vapor Service	6	7	8	9	10	11	13	14	15	16

Note: Spans shown in Tables 1 and 2 do not apply where there are concentrated loads between supports or where temperatures exceed 750°F.

TABLE 3: CPVC PIPE SUPPORT SPACING

Pipe Size (In.)	Schedule 40 Temperature (°F)						Schedule 80 Temperature (°F)					
	73°	100°	120°	140°	160°	180°	73°	100°	120°	140°	160°	180°
1/2	5	4 1/2	4 1/2	4	2 1/2	2 1/2	5 1/2	5	4 1/2	4 1/2	3	2 1/2
3/4	5	5	4 1/2	4	2 1/2	2 1/2	5 1/2	5 1/2	5	4 1/2	3	2 1/2
1	5 1/2	5 1/2	5	4 1/2	3	2 1/2	6	6	5 1/2	5	3 1/2	3
1 1/4	5 1/2	5 1/2	5 1/2	5	3	3	6 1/2	6	6	5 1/2	3 1/2	3
1 1/2	6	6	5 1/2	5	3 1/2	3	7	6 1/2	6	5 1/2	3 1/2	3 1/2
2	6	6	5 1/2	5	3 1/2	3	7	7	6 1/2	6	4	3 1/2
2 1/2	7	7	6 1/2	6	4	3 1/2	8	7 1/2	7 1/2	6 1/2	4 1/2	4
3	7	7	7	6	4	3 1/2	8	8	7 1/2	7	4 1/2	4
3 1/2	7 1/2	7 1/2	7	6 1/2	4	4	8 1/2	8 1/2	8	7 1/2	5	4 1/2
4	7 1/2	7 1/2	7	6 1/2	4 1/2	4	8 1/2	9	8 1/2	7 1/2	5	4 1/2
6	8 1/2	8	7 1/2	7	5	4 1/2	10	9 1/2	9	8	5 1/2	5
8	9 1/2	9	8 1/2	7 1/2	5 1/2	5	11	10 1/2	10	9	6	5 1/2
10	10 1/2	10	9 1/2	8	6	5 1/2	11 1/2	11	10 1/2	9 1/2	6 1/2	6
12	11 1/2	10 1/2	10	8 1/2	6 1/2	6	12 1/2	12	11 1/2	10 1/2	7 1/2	6 1/2
14	12	11	10	9	8	6	15	13 1/2	12 1/2	11	9 1/2	8
16	13	12	11	9 1/2	8 1/2	7	16	15	13 1/2	12	10	8 1/2

Note: Although support spacing is shown at 140°F, consideration should be given to the use of CPVC or continuous support above 120°F.

The possibility of temperature overrides beyond regular working temperatures and cost may either make either of the alternatives more desirable. This chart based on continuous spans and for un-insulated line carrying fluids of specific gravity up to 1.00.

The above table is meant as a general guideline, it is recommended that the pipe manufacturer be consulted for specific spacing recommendations relating to their pipe, load conditions, operating temperature and service conditions.

Local codes and specifications may also vary from the above recommended spacing and should be consulted for the applicable spacing requirements prior to installation.

TECHNICAL DATA

Pipe Support Spacing – PVC

Pipe Size (In.)	Schedule 40 Temperature (°F)					Schedule 80 Temperature (°F)					Schedule 120 Temperature (°F)				
	60	80	100	120	140	60	80	100	120	140	60	80	100	120	140
¼	4	3½	3½	2	2	4	4	3½	2½	2	–	–	–	–	–
⅜	4	4	3½	2½	2	4½	4½	4	2½	2½	–	–	–	–	–
½	4½	4½	4	2½	2½	5	4½	4½	3	2½	5	5	4½	3	2½
¾	5	4½	4	2½	2½	5½	5	4½	3	2½	5½	5	4½	3	3
1	5½	5	4½	3	2½	6	5½	5	3½	3	6	5½	5	3½	3
1¼	5½	5½	5	3	3	6	6	5½	3½	3	6½	6	5½	3½	3½
1½	6	5½	5	3½	3	6½	6	5½	3½	3½	6½	6½	6	4	3½
2	6	5½	5	3½	3	7	6½	6	4	3½	7½	7	6½	4	3½
2½	7	6½	6	4	3½	7½	7½	6½	4½	4	8	7½	7	4½	4
3	7	7	6	4	3½	8	7½	7	4½	4	8½	8	7½	5	4½
3½	7½	7	6½	4	4	8½	8	7½	5	4½	9	8½	7½	5	4½
4	7½	7	6½	4½	4	9	8½	7½	5	4½	9½	9	8½	5½	5
5	8	7½	7	4½	4	9½	9	8	5½	5	10½	10	9	6	5½
6	8½	8	7½	5	4½	10	9½	9	6	5	11½	10½	9½	6½	6
8	9	8½	8	5	4½	11	10½	9½	6½	5½	–	–	–	–	–
10	10	9	8½	5½	5	12	11	10	7	6	–	–	–	–	–
12	11½	10½	9½	6½	5½	13	12	10½	7½	6½	–	–	–	–	–
14	12	11	10	7	6	13½	13	11	8	7	–	–	–	–	–
16	12½	11½	10½	7½	6½	14	13½	11½	8½	7½	–	–	–	–	–
18	13	12	11	8	7	14½	14	12	11	9	–	–	–	–	–
20	14	12½	11½	10	8½	15½	14½	12½	11½	9½	–	–	–	–	–
24	15	13	12½	11	9½	17	15	14	12½	10½	–	–	–	–	–
	SDR 41					SDR 26					–				
18	13	12	11	8	7	14½	14	12	9	8	–	–	–	–	–
20	13½	12½	11½	8½	7½	15	14½	12½	9½	8½	–	–	–	–	–
24	14	13	12	9	8	15½	15	13	10	9	–	–	–	–	–

Note: Although support spacing is shown at 140°F, consideration should be given to the use of CPVC or continuous support above 120°F.

The possibility of temperature overrides beyond regular working temperatures and cost may either make either of the alternatives more desirable. This chart based on continuous spans and for un-insulated line carrying fluids of specific gravity up to 1.00.

The above table is meant as a general guideline, it is recommended that the pipe manufacturer be consulted for specific spacing recommendations relating to their pipe, load conditions, operating temperature and service conditions.

Local codes and specifications may also vary from the above recommended spacing and should be consulted for the applicable spacing requirements prior to installation.

Pipe Data – Steel

Schedule No. 40 & 80

Pipe Size	O.D.	Schedule No.	Wall Thickness	Weight per Foot (lbs)	Weight of Water per Foot (lbs)
3/8	0.675	40	0.091	0.568	0.083
		80	0.126	0.739	0.061
1/2	0.840	40	0.109	0.851	0.132
		80	0.147	1.088	0.101
3/4	1.050	40	0.113	1.131	0.230
		80	0.154	1.474	0.188
1	1.315	40	0.133	1.679	0.374
		80	0.179	2.172	0.311
1 1/4	1.660	40	0.140	2.273	0.648
		80	0.191	2.997	0.555
1 1/2	1.900	40	0.145	2.718	0.882
		80	0.200	3.631	0.765
2	2.375	40	0.154	3.653	1.455
		80	0.218	5.022	1.280
2 1/2	2.875	40	0.203	5.793	2.076
		80	0.276	7.661	1.837
3	3.500	40	0.216	7.580	3.20
		80	0.300	10.25	2.864
3 1/2	4.000	40	0.226	9.11	4.280
		80	0.318	12.51	3.850
4	4.500	40	0.237	10.79	5.510
		80	0.337	14.98	4.980
5	5.563	40	0.258	14.62	8.660
		80	0.375	20.78	7.870
6	6.625	40	0.280	18.97	12.51
		80	0.432	28.57	11.29
8	8.625	40	0.322	28.55	21.69
		80	0.500	43.39	19.800
10	10.75	40	0.365	40.48	34.10
		80	0.593	64.33	31.10
12	12.75	40	0.406	53.53	48.50
		80	0.687	88.51	44.00
14	14.000	40	0.437	63.37	58.70
		80	0.750	106.13	53.20
16	16.000	40	0.500	82.77	76.50
		80	0.843	136.46	69.70
18	18.000	40	0.562	104.75	97.00
		80	0.937	170.75	88.50
20	20.000	40	0.593	122.91	120.4
		80	1.031	208.87	109.4
24	24.000	40	0.687	171.17	174.3
		80	1.218	296.36	158.3
30	30.000	20	0.500	158.00	286.2
36	36.000	20	0.500	190.00	417.1

Straps
 Pipe Supports
 Trapeze
 Pipe Shields & Saddles
 Pipe Roll
 Pipe Guides & Slides
 Spring Hangers
 Constant Supports
 Vibration Control & Sway Brace
 Sway Strut Assembly
 Snubbers
 Special Design Products
 Application Examples
 Master Format 3 Part Specs.
Technical Data
 Index

TECHNICAL DATA

Pipe Data – Steel

Schedule No. 10

Pipe Size	O.D.	Wall Thickness	Weight per Foot (lbs)	Weight of Water per Foot (lbs)
1	1.315	0.109	1.404	0.409
1¼	1.660	0.109	1.81	0.71
1½	1.900	0.109	2.09	0.96
2	2.375	0.109	2.64	1.58
2½	2.875	0.120	3.53	2.36
3	3.500	0.120	4.33	3.61
3½	4.000	0.120	4.97	4.81
4	4.500	0.120	5.61	6.17
5	5.563	0.134	7.77	9.53
6	6.625	0.134	9.29	13.74
8	8.625	0.148	13.40	23.59
10	10.75	0.165	18.70	36.9
12	12.75	0.180	24.20	52.20
14	14.000	0.250	36.71	62.06
16	16.000	0.250	42.10	81.8
18	18.000	0.250	47.40	104.3
20	20.000	0.250	52.70	129.5
24	24.000	0.250	63.40	188.0

Copper Tube Data

Type L & K

TYPE L				
Tube Size	Tubing O.D.	Wall Thickness	Weight per Foot (lbs)	Weight of Water per Foot (lbs)
¼	0.375	.030	.126	.034
⅜	0.500	.035	.198	.062
½	0.625	.040	.285	.100
⅝	0.750	.042	.362	.151
¾	0.875	.045	.455	.209
1	1.125	.050	.655	.357
1¼	1.375	.055	.884	.546
1½	1.625	.060	1.140	.767
2	2.125	.070	1.750	1.341
2½	2.625	.080	2.480	2.064
3	3.125	.090	3.330	2.949
3½	3.625	.100	4.290	3.989
4	4.125	.110	5.380	5.188
5	5.125	.125	7.610	8.081
6	6.125	.140	10.200	11.616
8	8.125	.200	19.260	20.289
10	10.125	.250	30.100	31.590
12	12.125	.280	40.400	45.426

TYPE K				
Tube Size	Tubing O.D.	Wall Thickness	Weight per Foot (lbs)	Weight of Water per Foot (lbs)
¼	0.375	.035	.145	.032
⅜	0.500	.049	.269	.055
½	0.625	.049	.344	.094
⅝	0.750	.049	.418	.144
¾	0.875	.065	.641	.188
1	1.125	.065	.839	.337
1¼	1.375	.065	1.040	.527
1½	1.625	.072	1.360	.743
2	2.125	.083	2.060	1.310
2½	2.625	.095	2.920	2.000
3	3.125	.109	4.000	2.960
3½	3.625	.120	5.120	3.900
4	4.125	.134	6.510	5.060
5	5.125	.160	9.670	8.000
6	6.125	.192	13.870	11.200
8	8.125	.271	25.900	19.500
10	10.125	.338	40.300	30.423
12	12.125	.405	57.800	43.675

Soil Pipe Data

SERVICE WEIGHT CAST IRON (BELL & SPIGOT TYPE)				
Nom. Pipe Size	O.D. of Cast Iron Pipe	Wall Thickness	Weight per Foot (lbs)	Weight of Water per Foot (lbs)
2	2.25	.17	4.00	1.50
3	3.25	.17	6.00	3.40
4	4.25	.18	8.00	6.20
5	5.25	.18	10.40	12.30
6	6.25	.18	13.00	13.90
8	8.38	.23	20.00	25.70
10	10.50	.28	29.00	40.60
12	12.50	.28	38.00	58.20
15	15.62	.31	51.00	96.60

EXTRA WEIGHT CAST IRON (BELL & SPIGOT TYPE)				
Nom. Pipe Size	O.D. of Cast Iron Pipe	Wall Thickness	Weight per Foot (lbs)	Weight of Water per Foot (lbs)
2	2.38	.190	5.00	1.60
3	3.50	.250	9.00	3.70
4	4.50	.250	12.00	6.50
5	5.50	.250	15.00	10.20
6	6.50	.250	19.00	14.70
8	8.62	.310	30.00	26.10
10	10.75	.375	43.00	40.80
12	12.75	.375	54.00	58.80
15	15.88	.440	75.00	91.80

NO-HUB CAST IRON				
Nom. Pipe Size	O.D. of Cast Iron Pipe	Wall Thickness	Weight per Foot (lbs)	Weight of Water per Foot (lbs)
1½	1.90	.16	2.70	3.50
2	2.35	.16	3.60	5.00
3	3.35	.16	5.20	8.30
4	4.38	.19	7.40	12.80
5	5.30	.19	9.60	17.90
6	6.30	.19	11.00	23.00
8	8.38	.23	18.00	39.50
10	10.50	.28	26.20	43.34
12	12.50	.28	35.50	62.51

AWWA Ductile Iron Pipe Data

Nom. Pipe Size	Class	O.D. D.I. Pipe	Wall Thickness	Weight per Foot (lbs)	Weight of Water per Foot (lbs)
3	53	3.96	.31	11.20	3.80
4	53	4.80	.32	14.20	5.90
6	53	6.90	.34	22.00	13.10
8	53	9.05	.36	31.00	23.00
10	53	11.10	.38	40.40	36.40
12	53	13.20	.40	50.70	52.30
14	53	15.30	.42	62.40	71.10
16	53	17.40	.43	72.80	93.10
18	53	19.50	.44	83.60	117.90
20	53	21.60	.45	95.20	145.80
24	53	25.80	.47	119.20	210.20
30	53	32.00	.51	161.30	326.50
36	53	38.30	.58	219.50	469.30
42	53	44.50	.65	285.20	634.90
48	53	50.80	.72	360.30	828.90

Straps
Pipe Supports
Trapeze
Pipe Shields & Saddles
Pipe Roll
Pipe Guides & Slides
Spring Hangers
Constant Supports
Vibration Control & Sway Brace
Sway Strut Assembly
Snubbers
Special Design Products
Application Examples
Master Format 3 Part Specs.
Technical Data
Index

TECHNICAL DATA

PVC Plastic Pipe Data

Schedule No. 40 & 80

Pipe Size	O.D.	Schedule No.	Wall Thickness	Weight per Foot (lbs)	Weight of Water per Foot (lbs)
1/8	0.405	40	0.068	0.043	0.025
		80	0.095	0.055	0.016
1/4	0.540	40	0.088	0.074	0.045
		80	0.119	0.094	0.031
3/8	0.675	40	0.091	0.100	0.083
		80	0.126	0.129	0.061
1/2	0.840	40	0.109	0.150	0.132
		80	0.147	0.150	0.101
3/4	1.050	40	0.113	0.199	0.230
		80	0.154	0.259	0.186
1	1.315	40	0.133	0.295	0.374
		80	0.179	0.382	0.311
1 1/4	1.660	40	0.140	0.400	0.647
		80	0.191	0.527	0.555
1 1/2	1.900	40	0.145	0.478	0.882
		80	0.200	0.639	0.765
2	2.375	40	0.154	0.643	1.452
		80	0.218	0.884	1.279
2 1/2	2.875	40	0.203	1.020	2.072
		80	0.276	1.350	1.834
3	3.500	40	0.216	1.333	3.200
		80	0.300	1.804	2.860
3 1/2	4.000	40	0.226	1.598	4.280
		80	0.318	2.195	3.850
4	4.500	40	0.237	1.899	5.510
		80	0.337	2.636	4.980
5	5.563	40	0.258	2.770	8.660
		80	0.375	4.126	7.870
6	6.625	40	0.280	3.339	12.150
		80	0.432	5.028	11.290
8	8.625	40	0.322	5.280	21.600
		80	0.500	8.023	19.800
10	10.750	40	0.366	7.505	34.100
		80	0.593	11.894	31.100
12	12.750	40	0.406	10.023	48.500
		80	0.687	16.365	44.000

Thermal Expansion of Pipe Material

THERMAL EXPANSION OF PIPE MATERIAL – (IN/FT)										
Temp °F	Carbon Steel - Low Chrome Steel (thru 3% Cr)									
	0	10	20	30	40	50	60	70	80	90
-200	-0.0180	-0.0187	-0.0192	-0.0198	-0.0203	-0.0209	-0.0215	-0.0220	-0.0225	-0.0230
-100	-0.0121	-0.0127	-0.0133	-0.0140	-0.0146	-0.0152	-0.0158	-0.0163	-0.0169	-0.0174
0	-0.0051	-0.0058	-0.0065	-0.0073	-0.0080	-0.0087	-0.0096	-0.0103	-0.0109	-0.0116
0	-0.0051	-0.0044	-0.0037	-0.0029	-0.0022	-0.0015	-0.0007	0	0.0008	0.0015
100	0.0023	0.0030	0.0038	0.0046	0.0053	0.0061	0.0068	0.0076	0.0084	0.0091
200	0.0099	0.0107	0.0116	0.0124	0.0132	0.0141	0.0149	0.0157	0.0165	0.0174
300	0.0182	0.0191	0.0200	0.0208	0.0217	0.0226	0.0235	0.0244	0.0252	0.0261
400	0.0270	0.0279	0.0288	0.0298	0.0307	0.0316	0.0325	0.0334	0.0344	0.0353
500	0.0362	0.0372	0.0382	0.0391	0.0401	0.0411	0.0421	0.0431	0.0440	0.0450
600	0.0460	0.0470	0.0481	0.0491	0.0501	0.0512	0.0522	0.0532	0.0542	0.0553
700	0.0563	0.0574	0.0584	0.0595	0.0606	0.0617	0.0627	0.0638	0.0649	0.0659
800	0.0670	0.0681	0.0692	0.0703	0.0714	0.0726	0.0737	0.0748	0.0759	0.0770
900	0.0781	0.0792	0.0803	0.0813	0.0824	0.0835	0.0846	0.0857	0.0867	0.0878
1,000	0.0889	0.0901	0.0912	0.0924	0.0935	0.0946	0.0958	0.0970	0.0981	0.0993
1,100	0.1004	0.1015	0.1025	0.1036	0.1046	0.1057	0.1068	0.1078	0.1089	0.1099
1,200	0.1110	0.1121	0.1132	0.1144	0.1155	0.1166	0.1177	0.1188	0.1200	0.1211
1,300	0.1222	0.1233	0.1244	0.1256	0.1267	0.1278	0.1299	0.1320	0.1342	0.1363
1,400	0.1334	-	-	-	-	-	-	-	-	-

THERMAL EXPANSION OF PIPE MATERIAL – (IN/FT)										
Temp °F	Austenitic Stainless Steels (304, 316, 347)									
	0	10	20	30	40	50	60	70	80	90
-200	-0.0281	-0.0295	-0.0305	-0.0314	-0.0324	-0.0334	-0.0343	-0.0353	-0.0362	-0.0372
-100	-0.0187	-0.0197	-0.0207	-0.0216	-0.0226	-0.0236	-0.0245	-0.0254	-0.0263	-0.0272
0	-0.0078	-0.0089	-0.0100	-0.0112	-0.0123	-0.0134	-0.0145	-0.0155	-0.0166	-0.0176
0	-0.0078	-0.0067	-0.0056	-0.0044	-0.0033	-0.0022	-0.0011	0	0.0012	0.0023
100	0.0034	0.0045	0.0056	0.0068	0.0079	0.0090	0.0101	0.0112	0.0124	0.0135
200	0.0146	0.0158	0.0169	0.0181	0.0192	0.0203	0.0215	0.0227	0.0238	0.0250
300	0.0261	0.0273	0.0285	0.0297	0.0309	0.0321	0.0332	0.0344	0.0356	0.0368
400	0.0380	0.0392	0.0404	0.0416	0.0428	0.0440	0.0453	0.0465	0.0477	0.0489
500	0.0501	0.0513	0.0526	0.0538	0.0550	0.0562	0.0575	0.0587	0.0599	0.0612
600	0.0624	0.0637	0.0649	0.0662	0.0674	0.0687	0.0700	0.0712	0.0725	0.0737
700	0.0750	0.0763	0.0776	0.0789	0.0802	0.0815	0.0828	0.0841	0.0854	0.0867
800	0.0880	0.0893	0.0906	0.0920	0.0933	0.0946	0.0959	0.0972	0.0986	0.0999
900	0.1012	0.1260	0.1039	0.1053	0.1066	0.1080	0.1094	0.1107	0.1121	0.1134
1,000	0.1148	0.1162	0.1175	0.1189	0.1202	0.1216	0.1229	0.1243	0.1257	0.1270
1,100	0.1284	0.1298	0.1311	0.1325	0.1338	0.1352	0.1366	0.1379	0.1393	0.1406
1,200	0.1420	0.1434	0.1447	0.1461	0.1474	0.1488	0.1502	0.1515	0.1529	0.1542
1,300	0.1556	0.1570	0.1583	0.1597	0.1610	0.1624	0.1638	0.1651	0.1665	0.1678
1,400	0.1692	0.1704	0.1717	0.1731	0.1744	0.1757	0.1771	0.1784	0.1796	0.1811

Note: Intersect "10" Degree increments across the top of each table with the "100" degree increments down the left side to determine the coefficient of thermal expansion for the desired temperature.

Thermal Expansion of Pipe Material

THERMAL EXPANSION OF PIPE MATERIAL – (IN/FT)				
Temp °F	Intermediate Alloy Steels (5% thru 9% Cr Mo)	Copper	Brass	Aluminum
-200	–	-0.0275	-0.2870	-0.0373
-150	–	-0.0231	-0.0241	-0.0310
-100	–	-0.1830	-0.1900	-0.0244
-50	–	-0.1320	-0.0137	-0.0176
0	–	-0.0790	-0.0081	-0.0104
50	–	-0.0022	-0.0023	-0.0030
70	0.0000	0.0000	0.0000	0.0000
100	0.0022	0.0034	0.0035	0.0046
150	0.0058	0.0091	0.0093	0.0123
200	0.0094	0.0151	0.0152	0.0200
250	0.0132	0.0208	0.0214	0.0283
300	0.0171	0.0267	0.0276	0.0366
350	0.0210	0.0327	0.0340	0.0452
400	0.0250	0.0388	0.0405	0.0539
450	0.0292	0.0449	0.0472	0.0628
500	0.0335	0.0512	0.0540	0.0717
550	0.0379	0.0574	0.0610	0.0810
600	0.0424	0.0639	0.0680	0.0903
650	0.0469	0.0703	0.0753	–
700	0.0514	0.0768	0.0826	–
750	0.0562	0.0834	0.0902	–
800	0.0610	0.0900	0.0978	–
850	0.0658	0.0967	0.1056	–
900	0.0707	0.1037	0.1135	–
950	0.0756	0.1105	0.1216	–
1,000	0.0806	0.1175	0.1298	–
1,050	0.0855	–	–	–
1,100	0.0905	–	–	–
1,150	0.0952	–	–	–
1,200	0.1000	–	–	–
1,250	0.1053	–	–	–
1,300	0.1106	–	–	–
1,350	0.1155	–	–	–
1,400	0.1205	–	–	–

Threaded Rod Data

LOAD CARRYING CAPACITIES OF THREADED HANGER RODS. MATERIALS CARBON STEEL WITH MINIMUM ACTUAL TENSILE STRENGTH OF 50 KSI.				
Rod Diameter (in)	Threads per Inch	Root Area of Coarse Thread (in ²)	Maximum Safe Load (lbs) Rod Temperature, 650° F	Maximum Safe Load (lbs) Rod Temperature, 750° F
3/8	16 UNC	0.0678	730	572
1/2	13 UNC	0.126	1,350	1,057
5/8	11 UNC	0.202	2,160	1,692
3/4	10 UNC	0.302	3,230	2,530
7/8	9 UNC	0.419	4,480	3,508
1	8 UNC	0.551	5,900	4,620
1 1/4	7 UNC	0.890	9,500	7,440
1 1/2	6 UNC	1.29	13,800	10,807
1 3/4	5 UNC	1.74	18,600	14,566
2	4 1/2 UNC	2.30	24,600	19,265
2 1/4	4 1/2 UNC	3.02	32,300	25,295
2 1/2	4 UNC	3.72	39,800	31,169
2 3/4	4 UNC	4.62	49,400	38,687
3	4 UNC	5.62	60,100	47,066
3 1/4	4 UNC	6.72	71,900	56,307
3 1/2	4 UNC	7.92	84,700	66,331
3 3/4	4 UNC	9.21	98,500	77,139
4	4 UNC	10.6	114,000	88,807
4 1/4	4 UN	12.1	129,000	101,337
4 1/2	4 UN	13.7	146,000	114,807
4 3/4	4 UN	15.4	165,000	128,982
5	4 UN	17.2	184,000	144,096

Standard UNC thread thru 4" diameter and 4-UN-2A thread series for 4 1/4" diameter and larger

Maximum Recommended Applied Torques

FOR FIG. 261 & CT-121 RISER CLAMPS	
Bolt Size	Torque Value (ft.- lbs)
1/4	6
5/16	11
3/8	21
7/16	32
1/2	46
5/8	100
3/4	150
7/8	190
1	280

Bolts per ASTM A307
Nuts per ASTM A563

FOR SET SCREWS IN MSS TYPE 19 & 23 C-CLAMP	
Thread Size	Torque Value (in.- lbs)
1/4	40
3/8	60
1/2	125
5/8	250
3/4	400
7/8	665

Extracted from MSS-SP-69

TECHNICAL DATA

Beam Dimensions

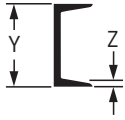

AMERICAN STANDARD CHANNELS			
Depth of Section Y	Weight per Ft., lb.	Flange Width	Mean Thick of Flange Z
3	4.1	1 ³ / ₈	0.250
	5.0	1 ¹ / ₂	
	6.0	1 ⁵ / ₈	
4	5.4	1 ³ / ₈	0.313
	7.25	1 ³ / ₄	
5	6.7	1 ³ / ₄	0.313
	9.0	1 ⁷ / ₈	
6	8.2	1 ⁷ / ₈	0.375
	10.5	2	
	13.0	2 ¹ / ₈	
7	9.8	2 ¹ / ₈	0.375
	12.25	2 ¹ / ₄	
	14.75	2 ¹ / ₄	
8	11.5	2 ¹ / ₄	0.375
	13.75	2 ³ / ₈	
	18.75	2 ¹ / ₂	
9	13.4	2 ³ / ₈	0.438
	15.0	2 ¹ / ₂	
10	20.0	2 ⁵ / ₈	0.438
	15.3	2 ⁵ / ₈	
	20.0	2 ³ / ₄	
10	25.0	2 ⁷ / ₈	0.438
	30.0	3	
	20.7	3	
12	25.0	3	0.500
	30.0	3 ¹ / ₈	
	33.9	3 ³ / ₈	
15	40.0	3 ¹ / ₂	0.625
	50.0	3 ³ / ₄	
	42.7	4	
18	45.8	4	0.625
	51.9	4 ¹ / ₈	
	58.0	4 ¹ / ₄	

S SHAPES			
Depth of Section Y	Weight per Ft., lb.	Flange Width	Mean Thick of Flange Z
3	5.7	2 ³ / ₈	0.250
	7.5	2 ¹ / ₂	
4	7.7	2 ⁵ / ₈	0.313
	9.5	2 ³ / ₄	
5	10.0	3	0.313
	14.75	3 ¹ / ₄	
6	12.5	3 ³ / ₈	0.375
	17.25	3 ⁵ / ₈	
7	15.3	3 ⁵ / ₈	0.375
	20.0	3 ⁷ / ₈	
8	18.4	4	0.438
	23.0	4 ¹ / ₈	
10	25.4	4 ⁵ / ₈	0.500
	35.0	5	
12	31.8	5	0.563
	35.0	5 ¹ / ₈	
	40.8	5 ¹ / ₄	
15	50.0	5 ¹ / ₂	0.625
	42.9	5 ¹ / ₂	
	50.0	5 ⁵ / ₈	
18	54.7	6	0.688
	70.0	6 ¹ / ₄	
	66.0	6 ¹ / ₄	
20	75.0	6 ³ / ₈	0.813
	66.0	6 ¹ / ₄	
20.3	86.0	7	0.938
	96.0	7 ¹ / ₄	
	80.0	7	
24	90.0	7 ¹ / ₈	0.875
	100.0	7 ¹ / ₄	
	80.0	7	

W SHAPES			
Depth of Section Y	Weight per Ft., lb.	Flange Width	Mean Thick of Flange Z
5	19	5	0.430
6	25	6 ¹ / ₈	0.455
	18	5 ¹ / ₄	0.330
8	21	5 ¹ / ₄	0.400
	24	6 ¹ / ₂	0.400
	28	6 ¹ / ₂	0.465
	31	8	0.435
	35	8	0.495
	40	8 ¹ / ₈	0.560
	48	8 ¹ / ₈	0.685
	58	8 ¹ / ₄	0.810
	67	8 ¹ / ₄	0.935
	10	22	5 ³ / ₄
26		5 ³ / ₄	0.440
30		5 ³ / ₄	0.510
33		8	0.435
39		8	0.530
45		8	0.620
49		10	0.560
54		10	0.615
60		10 ¹ / ₈	0.680
68		10 ¹ / ₈	0.770
12	77	10 ¹ / ₄	0.870
	88	10 ¹ / ₄	0.990
	26	6 ¹ / ₂	0.380
	30	6 ¹ / ₂	0.440
	35	6 ¹ / ₂	0.520
	40	8	0.515
	45	8	0.575
	50	8 ¹ / ₈	0.640
	53	10	0.575
	58	10	0.640
14	65	12	0.605
	72	12	0.670
	79	12 ¹ / ₈	0.735
	87	12 ¹ / ₈	0.810
	96	12 ¹ / ₈	0.900
	106	12 ¹ / ₄	0.990
	30	6 ³ / ₄	0.385
	34	6 ³ / ₄	0.455
	38	6 ³ / ₄	0.515
	43	8	0.530
14	48	8	0.595
	53	8	0.660
	61	10	0.645
	68	10	0.720
	74	10 ¹ / ₈	0.785
	82	10 ¹ / ₈	0.855
	90	14 ¹ / ₂	0.710

W SHAPES			
Depth of Section Y	Weight per Ft., lb.	Flange Width	Mean Thick of Flange Z
14	99	14 ⁵ / ₈	0.780
	109	14 ⁵ / ₈	0.860
	120	14 ⁵ / ₈	0.940
	132	14 ³ / ₄	1.030
16	36	7	0.430
	40	7	0.505
	45	7	0.565
	50	7 ¹ / ₈	0.63
	57	7 ¹ / ₈	0.715
	67	10 ¹ / ₄	0.665
	77	10 ¹ / ₄	0.760
	89	10 ³ / ₈	0.875
18	100	10 ³ / ₈	0.985
	50	7 ¹ / ₂	0.570
	55	7 ¹ / ₂	0.630
	60	7 ¹ / ₂	0.695
	65	7 ⁵ / ₈	0.750
	71	7 ⁵ / ₈	0.810
	76	11	0.680
	86	11 ¹ / ₈	0.770
	97	11 ¹ / ₈	0.870
	106	11 ¹ / ₄	0.940
21	62	8 ¹ / ₄	0.615
	68	8 ¹ / ₄	0.685
	73	8 ¹ / ₄	0.740
	83	8 ³ / ₈	0.835
	93	8 ³ / ₈	0.930
	101	12 ¹ / ₄	0.800
	111	12 ³ / ₈	0.875
	122	12 ³ / ₈	0.960
	76	9	0.680
	84	9	0.770
24	94	9 ¹ / ₈	0.875
	104	12 ³ / ₄	0.750
	117	12 ³ / ₄	0.850
	131	12 ⁷ / ₈	0.960
27	94	10	0.745
	102	10	0.830
	114	10 ¹ / ₈	0.930
	146	14	0.975
30	108	10 ¹ / ₂	0.760
	116	10 ¹ / ₂	0.850
	124	10 ¹ / ₂	0.930
	132	10 ¹ / ₂	1.000
33	118	11 ¹ / ₂	0.740
	130	11 ¹ / ₂	0.855
	141	11 ¹ / ₂	0.960
36	135	12	0.790
	150	12	0.940
	160	12	1.020

ANVIL COMPLIANCES, LISTINGS AND APPROVALS

Agency Listings and MSS-SP Types

Anvil Figure Number	Product Types			Application Sizes					
	MSS SP-58 & ANSI/MSS SP-69	Federal Specifications		FM* Rod Size	FM* Pipe Size	UL ■ Rod Size	UL ■ Pipe Size	ULC ▲ Rod Size	ULC ▲ Pipe Size
		WW-H-171-E	A-A-1192A						
14	27	54	27	-	-	-	-	-	-
40	42	-	42	-	-	-	-	-	-
45	-	-	-	-	-	-	-	-	-
46	-	-	-	-	-	-	-	-	-
47	-	-	-	-	-	-	-	-	-
49	-	-	-	-	-	-	-	-	-
50	-	-	-	-	-	-	-	-	-
52	-	-	-	-	-	-	-	-	-
54	-	-	-	-	-	-	-	-	-
55	57	57	57	-	-	-	-	-	-
55L	57	57	57	-	-	-	-	-	-
60	-	-	-	-	-	-	-	-	-
62	-	-	-	-	-	-	-	-	-
63	-	-	-	-	-	-	-	-	-
65	-	1	-	-	-	-	-	-	-
66	22	22	22	-	-	-	-	-	-
67	5	-	5	-	-	-	-	-	-
69	10	10	10	3/8	3/4 - 4	3/8	3/4 - 4	-	-
				1/2	5 - 8	1/2	5 - 8	-	-
86	23	23	23	3/8	3/4 - 4	3/8	3/4 - 4	3/8	3/4 - 4
				-	-	1/2	5 - 8	1/2	5 - 8
				-	-	3/4	12	3/4	12
				3/8	3/4 - 4	3/8	3/4 - 4	3/8	3/4 - 4
88	23	23	23	-	-	-	-	-	-
				-	-	3/4	12	3/4	12
				-	-	3/4	12	3/4	12
89	-	-	-	-	-	-	-	-	
89X	-	-	-	-	-	-	up to 8	-	up to 8
92	19 & 23	23	19 & 23	3/8	3/4 - 4	3/8	3/4 - 4	3/8	2 1/2 - 4
				1/2	5 - 8	1/2	5 - 8	1/2	5 - 8
93	19 & 23	23	19 & 23	3/8	3/4 - 4	3/8	3/4 - 4	3/8	2 1/2 - 4
				1/2	5 - 8	1/2	5 - 8	1/2	5 - 8
94	19	19	19	-	-	5/8	10, 12	-	-
				-	-	3/4	12	-	-
95	23	23	23	3/8, 1/2	-	3/8	-	-	-
100	-	-	-	-	-	-	-	-	-
103	-	-	-	-	-	-	-	-	-
104	6	6	6	-	-	-	-	-	-
108	11	11	11	-	-	-	-	-	-
110R	16	16	16	3/8	3/4 - 4	3/8	3/4 - 4	-	-
				1/2	5 - 8	1/2	5 - 8	-	-
				-	-	5/8	10, 12	-	-
				-	-	3/4	12	-	-
112	-	-	-	-	-	-	-	-	
113	-	-	-	-	-	-	-	-	
114	15	15	15	-	-	-	-	-	-
120	-	-	-	-	-	-	-	-	-
126	-	-	-	-	-	-	-	-	-
127	-	-	-	-	-	-	-	-	-
128R	-	-	-	-	-	-	-	-	-
133	21	21	21	-	-	3/8	3/4 - 4	-	-
				-	-	1/2	5 - 8	-	-

* = FM Approved ■ = UL Listed ▲ = ULC Listed



Straps
Pipe Supports
Trapeze
Pipe Shields & Saddles
Pipe Roll
Pipe Guides & Slides
Spring Hangers
Constant Supports
Vibration Control & Sway Brace
Sway Strut Assembly
Snubbers
Special Design Products
Application Examples
Master Format 3 Part Specs.
Technical Data
Index

ANVIL COMPLIANCES, LISTINGS AND APPROVALS

Agency Listings and MSS-SP Types

(cont.)

Anvil Figure Number	Product Types			Application Sizes					
	MSS SP-58 & ANSI/MSS SP-69	Federal Specifications		FM* Rod Size	FM* Pipe Size	UL ■ Rod Size	UL ■ Pipe Size	ULC ▲ Rod Size	ULC ▲ Pipe Size
		WW-H-171-E	A-A-1192A						
134	21	21	21	1/2	5 - 8	1/2	5 - 8	-	-
				5/8	10 - 12	5/8	10 - 12	-	-
135	-	-	-	-	-	-	-	-	-
135E	-	-	-	-	-	-	-	-	-
135R	-	-	-	-	-	-	-	-	-
136	-	-	-	3/8	3/4 - 4	3/8	3/4 - 4	3/8	3/4 - 4
	-	-	-	1/2	5 - 8	1/2	5 - 8	1/2	5 - 8
	-	-	-	-	-	5/8	10, 12	5/8	10, 12
	-	-	-	-	-	3/4	12	3/4	12
136R	-	-	-	-	-	7/8	12	7/8	12
	-	-	-	-	-	3/8	3/4 - 4	-	-
137	24	24	24	-	-	-	-	-	-
137C	24	24	24	-	-	-	-	-	-
137S	-	-	-	-	-	-	-	-	-
138R	12	25	12	-	-	-	-	-	-
140	-	-	-	-	-	-	-	-	-
142	-	-	-	-	-	-	-	-	-
146	-	-	-	-	-	-	-	-	-
148	-	-	-	-	-	-	-	-	-
152	-	-	-	3/8	3/4 - 2	3/8	3/4 - 4	3/8	3/4 - 4
	-	-	-	1/2	2 1/2 - 3 1/2	1/2	5 - 8	1/2	5 - 8
	-	-	-	5/8	4, 5	5/8	10, 12	5/8	10, 12
	-	-	-	3/4	6	3/4	12	3/4	12
	-	-	-	7/8	8	7/8	12	7/8	12
153	-	-	-	3/8	3/4 - 4	3/8	3/4 - 4	3/8	3/4 - 4
	-	-	-	1/2	5 - 8	1/2	5 - 8	1/2	5 - 8
	-	-	-	-	-	5/8	10, 12	5/8	10, 12
	-	-	-	-	-	3/4	12	3/4	12
157	-	-	-	-	-	-	12	-	12
	-	-	-	3/8	3/4 - 4	3/8	3/4 - 4	-	-
	-	-	-	1/2	5 - 8	1/2	5 - 8	-	-
	-	-	-	-	-	5/8	10, 12	-	-
	-	-	-	-	-	3/4	12	-	-
160	39A & 39B	40A & 40B	39A & 39B	-	-	-	-	-	-
161	39A & 39B	40A & 40B	39A & 39B	-	-	-	-	-	-
162	39A & 39B	40A & 40B	39A & 39B	-	-	-	-	-	-
163	39A & 39B	40A & 40B	39A & 39B	-	-	-	-	-	-
164	39A & 39B	40A & 40B	39A & 39B	-	-	-	-	-	-
165	39A & 39B	40A & 40B	39A & 39B	-	-	-	-	-	-
165A	39A & 39B	40A & 40B	39A & 39B	-	-	-	-	-	-
166A	39A & 39B	40A & 40B	39A & 39B	-	-	-	-	-	-
167	40	41	40	-	-	-	-	-	-
168	40	41	40	-	-	-	-	-	-
171	41	42	41	-	-	-	-	-	-
175	44	45	44	-	-	-	-	-	-
177	41	42	41	-	-	-	-	-	-
178	49	50	49	-	-	-	-	-	-
181	43	44	43	-	-	-	-	-	-
185	-	-	-	-	-	-	3/4 - 2	-	3/4 - 2
186	-	-	-	-	-	-	3/4 - 2	-	3/4 - 2
187	-	-	-	-	-	-	3/4 - 2	-	3/4 - 2
188	-	-	-	-	-	-	3/4 - 2	-	3/4 - 2
189	-	-	-	3/8	3/4 - 4	3/8	3/4 - 4	3/8	3/4 - 4

*= FM Approved ■ = UL Listed ▲ = ULC Listed

ANVIL COMPLIANCES, LISTINGS AND APPROVALS

Agency Listings and MSS-SP Types

(cont.)

Anvil Figure Number	Product Types			Application Sizes					
	MSS SP-58 & ANSI/MSS SP-69	Federal Specifications		FM* Rod Size	FM* Pipe Size	UL ■ Rod Size	UL ■ Pipe Size	ULC ▲ Rod Size	ULC ▲ Pipe Size
		WW-H-171-E	A-A-1192A						
190	–	–	–	3/8	3/4 - 4	3/8	3/4 - 4	3/8	3/4 - 4
191	37	38	37	–	–	–	–	–	–
192	38	39	38	–	–	–	–	–	–
194	31	32	31	3/8	3/4 - 4	–	–	–	–
				1/2	5 - 8	–	–	–	–
				–	–	–	–	–	–
				–	–	–	–	–	–
195	32	33	32	–	–	–	–	–	
199	33	34	33	–	–	–	–	–	
202	34	35	34	3/8	3/4 - 4	3/8	1 - 4	3/8	1 - 4
				1/2 (Steel beam)	5 - 8	1/2	5 - 8	1/2	5 - 8
				–	–	5/8	10, 12	5/8	10, 12
206	34	35	34	3/8 (Steel)	3/4 - 4	3/8	3/4 - 4	–	–
				1/2 (Steel)	5 - 8	1/2	5 - 8	–	–
				–	–	3/8	10, 12	–	–
207	34	35	34	3/8 (Steel)	3/4 - 4	3/8	3/4 - 4	–	–
				–	–	1/2	5 - 8	–	–
212	4	4	4	3/8	3/4 - 2	3/8	3/4 - 4	3/8	3/4 - 4
				1/2	2 1/2 - 3 1/2	1/2	5 - 8	1/2	5 - 8
				5/8	4, 5	–	–	–	–
				3/4	6	–	–	–	–
				7/8	8	–	–	–	–
212FP	4	4	4	–	–	–	–	–	
216	4	4	4	–	–	–	–	–	
217	25	–	25	–	–	–	–	–	
218	30	30	30	3/8	3/4 - 4	3/8	3/4 - 4	3/8	3/4 - 4
				–	–	1/2	5 - 8	1/2	5 - 8
				–	–	5/8	10, 12	5/8	10, 12
				–	–	3/4	12	3/4	12
				–	–	7/8	12	7/8	12
224	2	2	2	–	–	–	–	–	
227	25	–	25	3/8	3/4 - 4	3/8	3/4 - 4	–	–
		–		–	1/2	5 - 8	–	–	
228	28 & 29	30 & 31	28 & 29	–	–	–	–	–	
228L	28 & 29	30 & 31	28 & 29	–	–	–	–	–	
230	13	13	13	–	–	–	–	–	
233	13	13	13	–	–	–	–	–	
243	–	–	–	–	–	–	–	–	
244	–	–	–	–	–	–	–	–	
246	2	2	2	–	–	–	–	–	
248	–	–	–	–	–	–	–	–	
248L	–	–	–	–	–	–	–	–	
248X	–	–	–	–	–	–	–	–	
253	–	–	–	–	–	–	–	–	
255	–	–	–	–	–	–	–	–	
256	–	–	–	–	–	–	–	–	
257	35	–	35	–	–	–	–	–	
257A	–	–	–	–	–	–	–	–	
258	36	36 & 37	36	–	–	–	–	–	
259	37	–	37	–	–	–	–	–	

* = FM Approved ■ = UL Listed ▲ = ULC Listed



Straps
Pipe Supports
Trapeze
Pipe Shields & Saddles
Pipe Roll
Pipe Guides & Slides
Pipe Hangers
Spring Hangers
Constant Supports
Vibration Control & Sway Brace
Sway Strut Assembly
Snubbers
Special Design Products
Application Examples
Master Format 3 Part Specs.
Technical Data
Index

ANVIL COMPLIANCES, LISTINGS AND APPROVALS

Agency Listings and MSS-SP Types

(cont.)

Anvil Figure Number	Product Types		Application Sizes						
	MSS SP-58 & ANSI/MSS SP-69	Federal Specifications		FM* Rod Size	FM* Pipe Size	UL ■ Rod Size	UL ■ Pipe Size	ULC ▲ Rod Size	ULC ▲ Pipe Size
		WW-H-171-E	A-A-1192A						
260	1	1	1	3/8	3/4 - 2	3/8	3/4 - 4	3/8	3/4 - 4
				1/2	2 1/2 - 3	1/2	5 - 8	-	-
				5/8	4, 5	-	-	-	-
				3/4	6	-	-	-	-
				7/8	8	-	-	-	-
261	8	8	8	-	-	-	1 1/2 - 8	-	1 1/2 - 8
262	26	26	26	-	-	-	-	-	-
264	38	39	38	-	-	-	-	-	-
265	38	39	38	-	-	-	-	-	-
271	44	45	44	-	-	-	-	-	-
274	46	47	46	-	-	-	-	-	-
274P	-	-	-	-	-	-	-	-	-
275	-	-	-	-	-	-	-	-	-
277	45	46	45	-	-	-	-	-	-
278	-	-	-	-	-	-	-	-	-
278L	-	-	-	-	-	-	-	-	-
278X	-	-	-	-	-	-	-	-	-
281	18	19	18	3/8	3/4 - 4	3/8	3/4 - 4	3/8	3/4 - 4
				1/2	5 - 8	1/2	5 - 8	1/2	5 - 8
				5/8	8 MAX.	5/8	10, 12	5/8	10, 12
				3/4	8 MAX.	3/4	12	3/4	12
282	18	18	18	3/8	3/4 - 4	3/8	3/4 - 4	3/8	3/4 - 4
				1/2	5 - 8	1/2	5 - 8	1/2	5 - 8
				5/8	8 MAX.	5/8	10, 12	5/8	10, 12
				3/4	8 MAX.	3/4	12	3/4	12
				7/8	8 MAX.	7/8	12	7/8	12
284	-	-	-	-	-	-	-	-	-
285	19	18	18	3/8	3/4 - 4	3/8	3/4 - 4	3/8	3/4 - 4
				1/2	5	1/2	5 - 8	1/2	5 - 8
				-	-	5/8	10, 12	5/8	10, 12
286	18	18	18	-	-	-	-	-	-
290	17	17	17	-	-	-	-	-	-
290L	17	17	17	-	-	-	-	-	-
291	-	-	-	-	-	-	-	-	-
292	28 & 29	28 & 29	28 & 29	-	-	-	-	-	-
292L	28 & 29	28 & 29	28 & 29	-	-	-	-	-	-
295	3	3	3	-	-	-	-	-	-
295A	3	3	3	-	-	-	-	-	-
295H	3	3	3	-	-	-	-	-	-
299	14	14	14	-	-	-	-	-	-
300	1	1	1	-	-	-	-	-	-
395	-	-	-	-	-	-	-	-	-
432	-	-	-	-	-	-	-	-	-
436	35	-	35	-	-	-	-	-	-
436A	-	-	-	-	-	-	-	-	-
439	35	-	35	-	-	-	-	-	-
590	1	1	1	-	-	-	-	-	-
594	-	-	-	-	-	-	-	-	-
595	8	-	8	-	-	-	-	-	-
599	-	-	-	-	-	-	-	-	-
600	8	-	8	-	-	-	-	-	-

*= FM Approved ■ = UL Listed ▲ = ULC Listed

ANVIL COMPLIANCES, LISTINGS AND APPROVALS

Agency Listings and MSS-SP Types

(cont.)

Anvil Figure Number	Product Types		Application Sizes						
	MSS SP-58 & ANSI/MSS SP-69	Federal Specifications		FM* Rod Size	FM* Pipe Size	UL ■ Rod Size	UL ■ Pipe Size	ULC ▲ Rod Size	ULC ▲ Pipe Size
		WW-H-171-E	A-A-1192A						
CT-65	–	1	–	–	–	–	–	–	–
CT-69	10	10	10	–	–	–	–	–	–
CT-121	8	8	8	–	–	–	–	–	–
CT-128C	–	–	–	–	–	–	–	–	–
CT-138R	12	25	12	–	–	–	–	–	–
CT-255	–	–	–	–	–	–	–	–	–

A type is dependent upon its appropriate installation and use. Note: Figure 218 Must be used with Figure 157.

*= FM Approved ■ = UL Listed ▲ = ULC Listed

ENGINEERED HANGERS - COMPLIANCES, LISTINGS AND APPROVALS

Anvil Figure Number	Product Types		
	MSS-SP-58 & MSS-SP-69	Federal Specifications	
		WW-H-171-E	A-A-1192A
170 - Horizontal Traveler	58	-	-
200, C-200, 201 and C-201 - Hydraulic Snubbers	47	-	-
211, C-211, 640, C-640 - Sway Strut Assembly	-	-	-
222 and C-222 - Mini-Sway Strut Assembly	-	-	-
247 - Light Duty Spring	48	49	49
296, C-296, 297, C-297, 298, C-298, 301, C-301 & 302 - Sway Brace	50	55	55
312 - Tapered Pin	-	-	-
3306 & 3307 - Hydraulic Snubbers	47	-	-
Variable Spring Hangers			
82, B-268, 98, Triple, Quadruple Type A-E	51	51	51
C-82, C-268, C-98, Triple-CR, Quadruple-CR Type A-E	51	51	51
82, B-268, 98, Triple, Quadruple Type F	52	56	56
C-82, C-268, C-98, Triple-CR, Quadruple-CR Type F	52	56	56
82, B-268, 98, Triple, Quadruple Type G	53	57	57
C-82, C-268, C-98, Triple-CR, Quadruple-CR Type G	53	57	57
Constant Support Hangers			
80-V and C-80-V Type A-E	55	58	58
80-V and C-80-V Type G	56	59	59
81-H and C-81-H Type A-E	54	52	52



Straps
Pipe Supports
Trapeze
Pipe Shields & Saddles
Pipe Roll
Pipe Guides & Slides
Spring Hangers
Constant Supports
Vibration Control & Sway Brace
Sway Strut Assembly
Snubbers
Special Design Products
Application Examples
Master Format 3 Part Specs.
Technical Data
Index

ANVIL COMPLIANCES, LISTINGS AND APPROVALS

Manufacturers Standardization Society – Hanger Type Index

Type	Anvil Figure Number
MSS SP-58 & ANSI/MSS SP-69	
1	260 300 590
2	224 246
3	295 295A 295H
4	212 212FP 216
5	67
6	104
8	261 595 600 CT-121
10	69 CT-69
11	108
12	138R CT-138R
13	230 233
14	299
15	114
16	110R
17	290 290L
18	281 282 286
19	92 93 94 285
21	133 134
22	66
23	86 88 92 93 95
24	137 137C
25	217 227

Type	Anvil Figure Number
MSS SP-58 & ANSI/MSS SP-69	
26	262
27	14
28	228 228L 292 292L
30	218
29	228 228L 292 292L
31	194
32	195
33	199
34	202 206 207
35	257 436 439
36	258
37	191 259
38	192 264 265
39A & 39B	160 161 162 163 164 165 165A 166A
40	167 168
41	171 177
42	40
43	181
44	175 271
45	277
46	274
47	200, C-200 201, C-201 3306 3307

Type	Anvil Figure Number
MSS SP-58 & ANSI/MSS SP-69	
48	247
49	178
50	296, C-296 297, C-297 298, C-298 301, C-301 302
51	Type A-E 82, C-82 98, C-98 B-268, C-268 Triple Spring Hanger Triple-CR Spring Hanger Quadruple Spring Hanger Quadruple-CR Spring Hanger
52	Type F 82, C-82 98, C-98 B-268, C-268 Triple Spring Hanger Triple-CR Spring Hanger Quadruple Spring Hanger Quadruple-CR Spring Hanger
53	Type G 82, C-82 98, C-98 B-268, C-268 Triple Spring Hanger Triple-CR Spring Hanger Quadruple Spring Hanger Quadruple-CR Spring Hanger
54	81-H Type A-E C-81-H Type A-E
55	80-V Type A-E C-80-V Type A-E
56	80-V Type G C-80-V Type G
57	55 55L
58	170

Pipe Hanger & Support

- Hardware Hangers Complete Product Line of:
 - Carbon Steel, Stainless Steel
 - Cast Iron, Malleable Iron
 - Copper & PVC Coated
 - Plain, Galvanized & Painted
- Engineered Hangers
 - Variable Springs
 - Constant Supports
 - Hydraulic Snubbers
 - Vibration Sway Braces
 - Sway Struts
 - Limit Stops
- Special Structural Steel, Fabrication/Miscellaneous
- Special Design Products per Customer Specifications
- Domestic Manufactured Product Line

Anvil Markets

- Fire Protection
- Mechanical HVAC/Plumbing
- Industrial
- Petro Chemical
- Refinery
- Pulp & Paper
- Waste Water, Water Treatment
- Marine
- Co-generation
- Fossil Power
- Nuclear Power
- Seismic

Technical Services

- Design services, either on or off site, help you maximize the efficiency of your pipe support systems. These services include:
 - Pipe Hanger design and engineering
 - Drafting Services
 - System Analysis
 - Pipe Stress Analysis
 - Product Qualification Testing
 - Supervision of client design personnel
- HYDRAULIC SNUBBERS:
 - The Pipe Support Division has the technical expertise, manufacturing facilities and testing equipment to provide extensive design, installation, maintenance and repair or rebuild services for hydraulic shock suppressors.
- On site service available by certified technicians for fossil and nuclear plants.

Pipe Hanger Specifications

- Federal Spec WW-H-171E and A-A-1192A
- Underwriters Laboratory
- Factory Mutual (FM)
- Manufacturers Standardization Society (MSS) SP-58, SP-69, SP-77, SP-89 and SP-90
- National Fire Protection Association (NFPA)
- ASME Boiler and Pressure Vessel Code
 - Section III (Nuclear)
 - B31.1 Power Piping
 - B31.3 Chemical Plant and Petroleum Refinery Piping
 - B31.9 Building Services Piping
- MIL Spec P-15877 Marine Hangers
- FIELD SERVICES:
 - Support walk downs and verification
 - QA/QC services for on site or off site work
 - Support adjustments and materials
 - QA inspection and verification
 - Integrity Analysis
 - Non-destructive Examination
 - Training Programs
- Nuclear services geared to nuclear power market include:
 - Section XI Services
 - Compliance with NRC directives involving piping systems and components
 - Accredited by and granted an "NPT" Certificate of Authorization and "NS" Certificate of Accreditation
 - Quality activities audited by NUPIIC and various individual utilities
 - Commercial grade dedication program.

Electronic Pipe Support Catalog

- Available on-line on our web site
- Export CAD drawings to most CAD programs (EPS, DXF and DWG).
- Quick Retrieval of Product Data
- A Faster Way to Build Product Submittals

Web Site Address

<http://www.anvilintl.com>

Straps

Pipe Supports

Trapeze

Pipe Shields & Saddles

Pipe Roll

Pipe Guides & Slides

Spring Hangers

Constant Supports

Vibration Control & Sway Brace

Sway Strut Assembly

Snubbers

Special Design Products

Application Examples

Master Format 3 Part Specs.

Technical Data

Index

ANVIL TERMS OF SALE AND CONDITIONS

1. CONTROLLING PROVISIONS: These terms and conditions shall control with respect to any purchase order or sale of Seller's products. No waiver, alteration or modification of these terms and conditions whether on Buyer's purchase order or otherwise shall be valid unless the waiver, alteration or modification is specifically accepted in writing and signed by an authorized representative of Seller.

2. DELIVERY: Seller will make every effort to complete delivery of products as indicated on Seller's acceptance of an order, but Seller assumes no responsibility or liability, and will accept no back charge, for loss or damage due to delay or inability to deliver caused by acts of God, war, labor difficulties, accident, delays of carriers, by contractors or suppliers, inability to obtain materials, shortages of fuel and energy, or any other causes of any kind whatever beyond the control of Seller. Seller may terminate any contract of sale of its products without liability of any nature, by written notice to Buyer, in the event that the delay in delivery or performance resulting from any of the aforesaid causes shall continue for a period of sixty (60) days. Under no circumstances shall Seller be liable for any special or consequential damages or for loss, damage, or expense (whether or not based on negligence) directly or indirectly arising from delays or failure to give notice of delay.

3. WARRANTY: Seller warrants for one year from the date of shipment Seller's manufactured products to the extent that Seller will replace those having defects in material or workmanship when used for the purpose and in the manner which Seller recommends. If Seller examination shall disclose to its satisfaction that the products are defective, and an adjustment is required, the amount of such adjustment shall not exceed the net sales price of the defective products and no allowance will be made for labor or expense of repairing or replacing defective products or workmanship of damage resulting from the same. Seller warrants the products which it sells of other manufacturers to the extent of the warranties of their respective makers. Where engineering design or fabrication work is supplied, Buyer's acceptance of Seller's design or of delivery of work shall relieve Seller of all further obligation, other than expressed in Seller's product warranty. THIS IS SELLER'S SOLE WARRANTY. SELLER MAKES NO OTHER WARRANTY OF ANY KIND, EXPRESSED OR IMPLIED AND ALL IMPLIED WARRANTIES OF MERCHANTABILITY AND FOR A PARTICULAR PURPOSE WHICH EXCEED SELLER'S AFORESTATED OBLIGATION ARE HEREBY DISCLAIMED BY SELLER AND EXCLUDED FROM THIS WARRANTY. Seller neither assumes, nor authorizes any person to assume for it, any other obligation in connection with the sale of its engineering designs or products. This warranty shall not apply to any products or parts of products which (a) have been repaired or altered outside of Seller's factory, in any manner; (b) have been subjected to misuse, negligence or accidents; (c) have been used in a manner contrary to Seller's instructions or recommendations. Seller shall not be responsible for design errors due to inaccurate or incomplete information supplied by Buyer or its representatives.

4. SELLER'S LIABILITY: Seller will not be liable for any loss, damage, cost of repairs, incidental or consequential damages of any kind, whether based upon warranty (except for the obligation accepted by Seller under "Warranty" above), contract or negligence, arising in connection with the design, manufacture, sale, use or repair of the products or of the engineering designs supplied to Buyer.

5. RETURNS: Seller cannot accept return of any products unless its written permission has been first obtained, in which case same will be credited subject to the following: (a) all material returned must, on its arrival at Seller's Plant, be found to be in first-class condition; if not, cost of putting in saleable condition will be deducted from credit

memoranda; (b) a handling charge deduction of twenty percent (20%) will be made from all credit memoranda issued for material returned; and (c) transportation charges, if not prepaid will be deducted from credit memoranda.

6. SHIPMENTS: All products sent out will be carefully examined, counted and packed. The cost of any special packing or special handling caused by Buyer's requirements or requests shall be added to the amount of the order. No claim for shortages will be allowed unless made in writing within ten (10) days of receipt of a shipment. Claims for products damaged or lost in transit should be made on the carrier, as Seller's responsibility ceases, and title passes, on delivery to the carrier.

7. SPECIAL PRODUCTS: Orders covering special or nonstandard products are not subject to cancellation except on such terms as Seller may specify on application.

8. PRICES AND DESIGNS: Prices and designs are subject to change without notice. All prices are F.O.B. Point of shipment, unless otherwise stated.

9. TAXES: The amount of any sales, excise or other taxes, if any, applicable to the products covered by this order, shall be paid by Buyer unless Buyer provides Seller with an exemption certificate acceptable to the taxing authorities.

10. NUCLEAR PLANTS: Where the products, engineering design or fabrication are utilized in nuclear plant applications, Buyer agrees: (a) to take all necessary steps to add Seller as an insured under the property insurance policies and nuclear liability insurance policies covering the nuclear power plant facility at which the products, engineering design or fabrication are utilized; (b) to obtain a waiver of any claims against Seller by the nuclear power plant owner and a waiver of subrogation against Seller from such owners' property insurer with respect to any loss or damage to property at the nuclear power plant site arising from the products, engineering design or fabrication; (c) to indemnify and hold Seller harmless against all claims, costs, expenses (including attorneys fees), loss, damage, or other liability that Seller would not have incurred but for Buyer's failure to comply with subsections (a) and (b) of this Section 10; and (d) to indemnify and hold Seller harmless with respect to any personal injury (or death), property damage or other loss resulting from a nuclear incident which is caused directly or indirectly by defective design, material or workmanship furnished by Seller.

11. MINIMUM INVOICE: \$100.00 plus transportation.

12. TERMS: Cash, net 30 days unless otherwise specified.

NOTE: All orders are accepted on the basis of prices in effect at the time of shipment.

NOTICE: The prices and terms quoted, there will be added any manufacturers or sales tax payable on the transaction under any effective statute.

FREIGHT ALLOWANCE: All prices are F.O.B. point of shipment. On (non-engineered product) shipments of 2,500 pounds or more, rail freight or motor freight at the lowest published rates is allowed to all continental U.S. rail points or all U.S. highway points listed in published tariffs (Alaska and Hawaii excluded). In no case will more than actual freight be allowed.

EXCEPTIONS: All Constant Supports, Spring Hangers, Sway Braces and all Engineered, Bundled and Tagged Hanger Assemblies are F.O.B. Plants, with No Freight Allowed.

Subject Index

Table of Contents	4 - 5
Photo Index	6 - 14
General Notes	15 - 17
Copper Tubing Hangers	18 - 25
CPVC Pipe Hangers	26 - 29
Pipe Rings	30 - 33
Clevis	34 - 41
Steel Pipe Clamps	42 - 52
Socket Clamps	53 - 54
Beam Clamps	55 - 66
Structural Attachments	67 - 71
Brackets	72 - 78
Ceiling Plates & Flanges	79 - 81
Concrete Inserts & Attachments	82 - 90
Hanger Rods	91 - 94
Rod Attachments	95 - 99
Bolts, Nuts, Pins & U-Bolts	100 - 103
Straps	104 - 105
Pipe Supports	106 - 112
Trapeze	113 - 115
Pipe Shields & Saddles	116 - 121
Pipe Rolls	122 - 129
Pipe Guide & Slides	130 - 141
Spring Hangers	142 - 159
Constant Supports	160 - 184
Vibration Control & Sway Brace	185 - 187
Sway Strut Assembly	188 - 191
Hydraulic Snubbers & Tapered Load Pin	192 - 200
Special Design Products	201 - 204
Application Assembly Examples	205 - 212
Pipe Hanger Specifications	213 - 214
Master Format 3 Part Specification	215 - 224

Technical Data Index (Note #1)

Pipe Support Spacing	225 - 226
Pipe Data	227 - 230
Thermal Expansion of Pipe Material	231 - 232
Threaded Rod Data	233
Torques: Riser Clamps & C-Clamps	233
Beam Dimensions	234
Anvil Compliances, Listings & Approvals	235 - 240
Anvil Pipe Hangers and Support Services	241
Anvil Terms of Sale and Conditions	242

Note #1: Charts and Tables

Charts and tables in this section are compiled from information published by nationally recognized organizations and are intended for use as a guide only. Anvil International ("Anvil") recommends that users of this information determine the validity of such information as applied to their own applications.

Straps

Pipe Supports

Trapeze

Pipe Shields & Saddles

Pipe Roll

Pipe Guides & Slides

Spring Hangers

Constant Supports

Vibration Control & Sway Brace

Sway Strut Assembly

Snubbers

Special Design Products

Application Examples

Master Format 3 Part Specs.

Technical Data

Index

Fig. 14 through Fig. 211

● = Columbia, PA ■ = North Kingstown, RI ▲ = Henderson, TN
 † = Regional Service Centers * = rod dia. over 1½" (North Kingstown, RI)
 For contact information for the locations listed above, please refer to the back cover.

Figure Number	Provided From	Page
Fig. 14	▲	62
Fig. 38SD	■▲	201
Fig. 40	■▲	43
Fig. 40SD	■▲	203
Fig. 41SD	■▲	203
Fig. 42SD	■▲	204
Fig. 45	■▲	114
Fig. 46	■▲	113
Fig. 47	▲*	88
Fig. 49	▲*	89
Fig. 50	■▲	115
Fig. 52	▲*	90
Fig. 53SD	■▲	201
Fig. 54	■	68
Fig. 55 & Fig. 55L	▲*	67
Fig. 60	▲*	70
Fig. 62 Type A, B & C	■▲	106
Fig. 63 Type A, B, C, P & T	■▲	107
Fig. 65	N/A	35
Fig. 66	▲	69
Fig. 67	▲	34
Fig. 67F	▲	22
Fig. 69	▲	33
Fig. 69F	▲	21
Fig. 71SD	■	201
Fig. 72SD	■	202
Fig. 75SD	■▲	202
Fig. 76SD	■▲	202
Fig. 80-V Type A	■	168
Fig. 80-V Type B	■	169
Fig. 80-V Type C	■	170
Fig. 80-V Type D	■	171
Fig. 80-V Type E	■	172
Fig. 80-V Type G	■	173
Fig. 80-V Type A, B & C	■	174
Fig. 81-H Type A	■	175
Fig. 81-H Type B	■	176
Fig. 81-H Type C	■	177
Fig. 81-H Type D	■	178
Fig. 81-H Type E	■	179
Fig. 81-H Type F Upthrust	■	180
Fig. 81-H Type A, B, C & E	■	181
Fig. 82	■	142 - 143, 152 - 153
Fig. 86 & Fig. 88	●	55
Fig. 89	▲	57
Fig. 89X	▲	57
Fig. 92	●	58
Fig. 93	●	59
Fig. 94	●	60
Fig. 95	▲	56
Fig. 98, Fig. C-98 Series	■	142 - 143, 154 - 155

Figure Number	Provided From	Page
Fig. 100	▲	44
Fig. 103	▲	44
Fig. 104	●	32
Fig. 108	●	30
Fig. 110R	●	96
Fig. 112	●	71
Fig. 113	●	71
Fig. 114	●	96
Fig. 120	▲	103
Fig. 126	●	104
Fig. 127	▲	79
Fig. 128R	●	80
Fig. 133	▲	63
Fig. 134	▲	63
Fig. 135, Fig. 135E & Fig. 135R	▲	95
Fig. 136 & Fig. 136R	●	95
Fig. 137, Fig. 137S & Fig. 137C	▲	102 - 103
Fig. 138R	N/A	31
Fig. 140	■▲	92
Fig. 142	▲	91
Fig. 146	†	91
Fig. 148	■	94
Fig. 152	●	82
Fig. 153	●	81
Fig. 157	●	97
Fig. 160 thru Fig. 166A	■▲	118 - 121
Fig. 167	▲	116
Fig. 168	▲	117
Fig. 170	■	184
Fig. 171	▲	123
Fig. 175	▲	126
Fig. 177	▲	122
Fig. 178	▲	124
Fig. 181	▲	125
Fig. 185	▲	26
Fig. 186	▲	27
Fig. 187	▲	28
Fig. 188	▲	29
Fig. 189	▲	74
Fig. 190	▲	75
Fig. 191	▲	108
Fig. 192	▲	108
Fig. 194	▲	76
Fig. 195	▲	77
Fig. 199	▲	78
Fig. 200, C-200	■	196 - 199
Fig. 201, C-201	■	196 - 199
Fig. 202	●	72
Fig. 206	▲	73
Fig. 207	▲	73
Fig. 211, C-211	■	188 - 189

Fig. 212 through Fig. CT-255

● = Columbia, PA ■ = North Kingstown, RI ▲ = Henderson, TN
 † = Regional Service Centers * = rod dia. over 1½" (North Kingstown, RI)
 For contact information for the locations listed above, please refer to the back cover.

Figure Number	Provided From	Page
Fig. 212	▲	45, 141
Fig. 212FP	▲	46
Fig. 216	▲	47
Fig. 217	▲	62
Fig. 218	●	64
Fig. 222, C-222	■	190 - 191
Fig. 224	■	51
Fig. 227	▲	61
Fig. 228	▲	65
Fig. 230	▲*	99
Fig. 233	■	99
Fig. 243	■▲	105
Fig. 244	■▲	105
Fig. 246	■	52
Fig. 248 & Fig. 248L	▲	92
Fig. 248X	▲	93
Fig. 253	▲*	92
Fig. 255	▲	130 - 131
Fig. 256	▲	132 - 133
Fig. 257	▲	134 - 137
Fig. 257A	▲	134 - 137
Fig. 258	▲	109
Fig. 259	▲	112
Fig. 260	▲	36
Fig. 260 ISS	▲	37 - 39
Fig. 261	▲	42
Fig. 262	▲	104
Fig. 264	▲	110
Fig. 265	▲	111
Fig. B-268, C-268 Type A	■	147
Fig. B-268, C-268 Type B & C	■	148
Fig. B-268, C-268 Type D & E	■	149
Fig. B-268, C-268 Type F	■	150
Fig. B-268, C-268 Type G	■	151
Fig. 271	▲	128
Fig. 274 & Fig. 274P	▲	129
Fig. 275	▲	129
Fig. 277	▲	127
Fig. 278 & Fig. 278L	▲*	93
Fig. 278X	▲*	93
Fig. 281	▲	84
Fig. 282	●	83
Fig. 284	▲	87
Fig. 285	▲	85
Fig. 286	†	86
Fig. 290 & Fig. 290L	▲*	97
Fig. 291	■▲	100
Fig. 292 & Fig. 292 L	▲	66
Fig. 295	▲	48
Fig. 295A	▲	49
Fig. 295H	■▲	50

Figure Number	Provided From	Page
Fig. 296, 301, C-296, C-301	■	185 - 186
Fig. 297, 298, 302, 303	■	187
Fig. 299	▲*	98
Fig. 300	▲	40
Fig. 312	■	200
Fig. 395	●	79
Fig. 432	▲	140
Fig. 436 & Fig. 436A	▲	134 - 137
Fig. 439 & Fig. 439A	▲	138 - 139
Fig. 590	▲	41
Fig. 595 & Fig. 594	▲	53
Fig. 600 & Fig. 599	▲	54
Fig. 640, C-640	■	188 - 189
Fig. 3306, 3307	■	192 - 195
Fig. CT-65	N/A	19
Fig. CT-69	▲	18
Fig. CT-121	▲	23
Fig. CT-128R	●	20
Fig. CT-138R	N/A	20
Fig. CT-255	▲	24 - 25

Anvil Compliances, Listings and Approvals	235 - 240
Anvil Pipe Hangers and Support Services	241
Anvil Terms of Sale and Conditions	242
Beam Dimensions	234
Constant Support, Check List	183
Constant Support, Total Travel & Selection Chart	164 - 167
Copper Tube Data	228
CPVC Pipe Support Spacing	225
Hexagon Nuts & Machine Bolts	101
Manufacturers Standardization Society - Hanger Type Index	240
Master Format 3 Part Specification	215 - 224
Maximum Recommended Applied Torques	233
Model R 80-V, 81-H Mathematically Perfect Pipe Support	160 - 163
Quadruple Spring, Quadruple Spring-CR Series	158 - 159
Spring Hanger Check List	146
Spring Hanger Size & Series Selection	144 - 145
Standard Galvanizing Practice	16 - 17
Standard Materials	15
Steel Pipe Data	227 - 228
Thermal Expansion of Pipe Material	231 - 232
Triple Spring, Triple Spring-CR Series	156 - 157
Typical Pipe Hanger Specification	213 - 214
Weight Chart - Fig. 80-V & Fig.81-H	182

Straps
 Pipe Supports
 Trapeze
 Pipe Shields & Saddles
 Pipe Roll
 Pipe Guides & Slides
 Spring Hangers
 Constant Supports
 Vibration Control & Sway Brace
 Sway Strut Assembly
 Snubbers
 Special Design Products
 Application Examples
 Master Format 3 Part Specs.
 Technical Data
Index





ANVIL[®]
INTERNATIONAL

Building Connections That Last

www.anvilintl.com

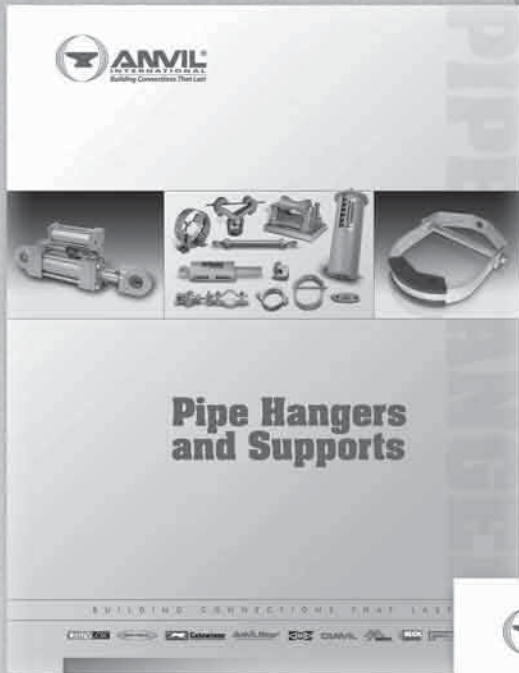

PIPE HANGERS & SUPPORT CATALOG
ORDER DOCUMENT #165

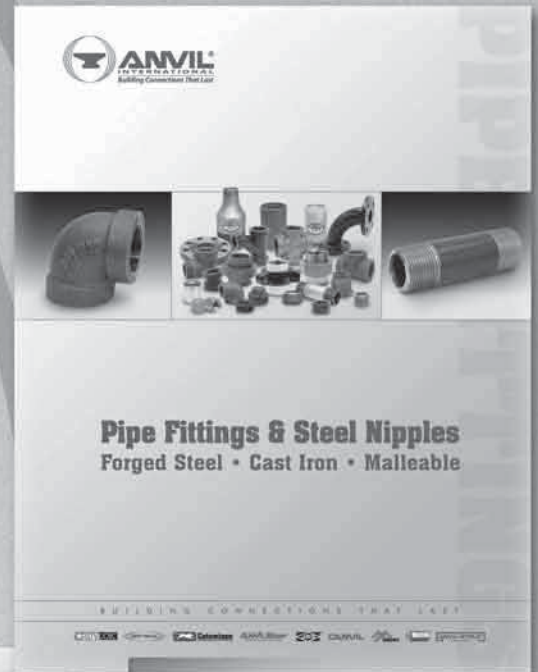

PIPE FITTINGS CATALOG
ORDER DOCUMENT #010



**ANVIL-STRUT METAL FRAMING
PRODUCT & ENGINEERING CATALOG**
ORDER DOCUMENT #125

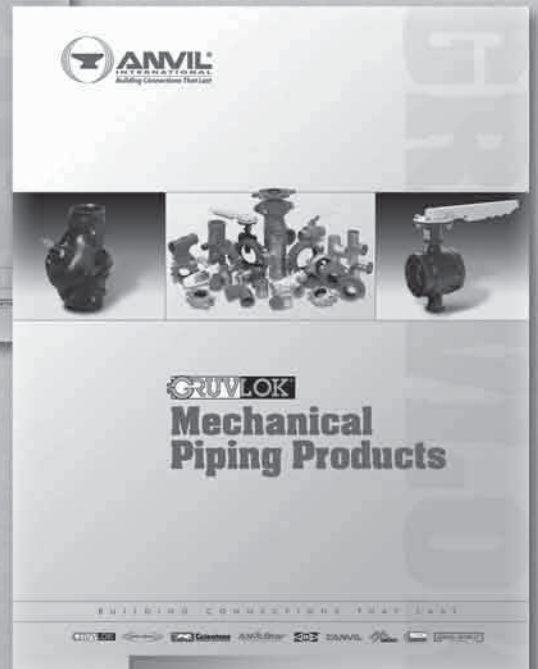

**GRUVLOK MECHANICAL
PIPING PRODUCTS CATALOG**
ORDER DOCUMENT #040



PIPE FITTERS HANDBOOK
ORDER DOCUMENT #030

Today Anvil® International is the largest and most complete fitting and hanger manufacturer in the world.

2004 Anvil® International acquires Star Pipe Products, Building and Construction Divisions (SPF) and forms AnvilStar™ Fire Products Division.

2001 Anvil® International acquires Merit® Manufacturing and Beck Manufacturing.

2000 The industry's trusted manufacturer of pipe fittings, hangers and grooved fittings is renamed Anvil® International, Inc.

1999 Tyco sells the distribution and manufacturing operations known up to this point as "Grinnell Supply Sales", but keeps the Grinnell® trademark.

1994 J.B. Smith™ and Catawissa™ join the Grinnell Supply Sales and Manufacturing division.

1969 Grinnell Co. acquired by International Telephone and Telegraph. Two years later, ITT divests the Fire Protection Division, but keeps the manufacturing and sales divisions that will become known as Anvil® International.

1960 Gruvlok® line of grooved fittings is introduced.

1919 General Fire Extinguisher Co. becomes Grinnell Co.

1909 Frederick Grinnell opens a foundry in Cranston, RI. Companies express interest in buying its piping products, laying the groundwork for what would become the Grinnell Supply Sales Division. It would be these manufacturing and sales operations that eventually become Anvil® International.

1850 Providence Steam & Gas Pipe Co. is formed, and Frederick Grinnell purchases a controlling interest.

Grinnell® is a registered trademark of Grinnell Corporation, a Tyco International Ltd. company.

TRUSTED FOR 150 YEARS

We built our reputation from the ground up.

Anvil's history stretches back to the mid 1800s, when a company named Grinnell® began providing its customers with the finest quality pipe products. Since 2000, those quality products and services—and the people who provide them—have been known as Anvil® International. Anvil® customers receive the quality and integrity that have been building strong connections in both products and business relationships for over 150 years.

Focused Product Line:

Anvil® Malleable and Cast Iron Fittings

Anvil® Hangers, Supports and Struts

Beck Welded Pipe Nipples

Anvil® Seamless Pipe Nipples

Anvil® Steel Pipe Couplings and Small Steel Fittings

Merit® Tee-Lets and Drop Nipples

Gruvlok® Couplings, Fittings and Valves

SPF™ Malleable and Cast and Ductile Iron Fittings

SPF™ Grooved Fittings and O'Lets

J.B. Smith Swage Nipples and Bull Plugs

Catawissa® Wing Unions and Check Valves



BUILDING CONNECTIONS THAT LAST



ANVIL BRANDS:



BRANDS OF ANVIL INTERNATIONAL



Anvil® product lines include malleable and cast iron fittings, unions and flanges; seamless steel pipe nipples; steel pipe couplings; universal anvilets; forged steel fittings and unions; pipe hangers and supports; threaded rod; and engineered hangers.



The Gruvlok® product line consists of couplings for grooved and plain-end fittings, butterfly valves and check valves; flanges; pump protection components; pipe grooving tools; as well as copper and stainless steel system components.



Anvil-Strut™ products include a complete line of channel in stock lengths of 10 and 20 feet, with custom lengths available upon request. A variety of fittings and accessories are also offered. All products can be ordered in an assortment of finishes and material choices including SupR-Green™, Zinc Trivalent Chromium, pre-galvanized, hot-dipped galvanized, electro-galvanized, aluminum, plain, and stainless steel.



JB Smith™ is the leading manufacturer of oil country tubular fittings, swages and bull plugs – all meeting API specifications. Offering tubing nipples, casing nipples as well as a full line of traditional line pipe and oil country threads in every schedule, JB Smith is the resource for all your oilfield needs.



Catawissa™ NACE and API approved wing unions for Standard Service are offered in non-pressure seal ends as well as threaded and butt weld, and are interchangeable with most leading union manufacturers. Fully traceable and available with complete mill certifications, Catawissa's oilfield wing union product line includes the standard ball-and-cone design plus our unique Figure 300 Flat Face design, where space and pipe line separation are a consideration.



The SPF/Anvil™ product line includes a variety of internationally sourced products such as grooved couplings, fittings and flanges, cast iron, malleable iron and ductile iron threaded fittings, steel pipe nipples, as well as o'lets.



The Merit® product line includes a variety of tee-lets, drop nipples, and steel welding flanges for fire protection applications. Most Merit products are UL/ULC Listed, FM Approved, and rated from 175 to 300 psi.



Steel pipe nipples and steel pipe couplings are manufactured in accordance with the ASTM A733 Standard Specification for Welded and Seamless Carbon Steel and Stainless Steel Pipe Nipples. Steel pipe couplings are manufactured in accordance with the ASTM A865 Standard Specification for Threaded Couplings, Steel, Black or Zinc-Coated (Galvanized) Welded or Seamless, for Use in Steel Pipe Joints. API couplings are manufactured in accordance with the API Specification for line pipe.



Canvil® manufactures low pressure hexagon reducer bushings, as well as plugs and hex caps up to 1" in diameter in various finishes including Oil Treat, Phosphate and Electro Galvanized. In addition, Canvil manufactures A105 hex or round material in class 3000 and 6000 pound, forged steel couplings and bar stock products offered as either as normalized (A105N) or non-normalized (A105) that are fully traceable for mechanicals and chemistry through our MTR program.



Anvil EPS-Engineered Pipe Supports are products used to support piping systems under thermal, seismic, and other dynamic loading conditions. The product line encompasses variable spring hangers, constant supports, sway struts and snubbers as well as standard and special design clamps. Anvil EPS brings the highest quality products and innovative engineering solutions to common and uncommon piping system problems.



Corporate Offices

110 Corporate Drive, Suite 10
P.O. Box 3180
Portsmouth, NH 03801-3180
Tel: 603-422-8000
Fax: 603-422-8033
E-mail: webmaster@anvilintl.com

U.S. REGIONAL SERVICE CENTERS

Northern Region

Regional Distribution & Customer Service Center

750 Central Avenue
University Park, IL 60484
Tel: 708-885-3000
Fax: 708-534-5441
Toll Free: 1-800-301-2701

Southern Region

Regional Distribution & Customer Service Center

1401 Valley View Lane, Suite 150
Irving, TX 75061
Tel: 972-871-1206
Fax: 972-641-8946
Toll Free: 1-800-451-4414

Anvil EPS

Engineered Pipe Supports
Customer Service Center

160 Frenchtown Road
North Kingstown, RI 02852
Tel: 401-886-3000
Fax: 401-886-3010
Toll Free: 1-877-406-3108

CANADA SERVICE CENTER

Anvil International Canada

Customer Service Center

390 Second Avenue
P.O. Box 40
Simcoe, Ontario N3Y 4K9
Tel: 519-426-4551
Fax: 519-426-5509

INTERNATIONAL SALES

Europe and Middle East Region

Rick van Meesen
rivanmeesen@anvilintl.com
Tel: +31-53-5725570
Fax: +31-53-5725579

Mexico, Puerto Rico and Latin America

International Customer Service
Tel: +1-708-885-3000
Fax: +1-708-534-5441

BUILDING CONNECTIONS THAT LAST

