



38-100 SERIES

ATMOSPHERIC TYPE VACUUM BREAKER

Job Name:	Contractor:
Job Location:	P.O. Number:
Engineer:	Representative:
Tag:	Wholesale Distributor:

DESCRIPTION

The Apollo® 38-100 Series Atmospheric Type Vacuum Breaker is designed to prevent contamination of potable water due to back-siphonage. This 38-100 Series valve is not designed for backpressure conditions or continuous pressure applications of more than 12 hours in a 24 hours period. This Apollo® 38-100 Series valve is recommended for low flow installations that use small amounts of water.



FEATURES

- Corrosion resistant bronze body
- Compact and easy to maintain
- Heat resistant silicone seat disc
- Suitable for hot or cold water service
- MADE IN THE USA



MATERIAL SPECIFICATIONS

Part Name	Material
Body	Cast Bronze
Seat Disc	Silicone
Float Gasket	Polypropylene
Guide	Brass
Seat	Cast Bronze
Canopy	Chrome-plated Steel
Float	Polypropylene

DIMENSIONS (in.)

Size	A	B	C	Wt. (lb.)
1/4"	7/8	2 3/8	1	.51
3/8"	7/8	2 3/8	1	.48
1/2"	1 1/8	2 1/2	1 1/4	.55
3/4"	1 3/8	3 1/8	1 1/2	.80
1"	1 3/4	4 1/8	1 7/8	1.74
1 1/4"	2	4 3/8	2	3.16
1 1/2"	2	4 3/8	2	2.89
2"	2 1/8	4 1/2	2 1/4	3.69

ORDERING INFORMATION

3 8 - 1 0 X - 0 X

SIZE: 3, 8
FINISH: X, 0

SIZE

- | | | |
|-------------------------------------|-----------------------------------|-------------------------------------|
| <input type="checkbox"/> 1 - 1/4" | <input type="checkbox"/> 2 - 3/8" | <input type="checkbox"/> 3 - 1/2" |
| <input type="checkbox"/> 4 - 3/4" | <input type="checkbox"/> 5 - 1" | <input type="checkbox"/> 6 - 1 1/4" |
| <input type="checkbox"/> 7 - 1 1/2" | <input type="checkbox"/> 8 - 2" | |

FINISH

- | |
|--|
| <input type="checkbox"/> 1 - Rough Brass |
| <input type="checkbox"/> 3 - Rough Chrome |
| <input type="checkbox"/> 4 - Polished Brass |
| <input type="checkbox"/> 6 - Polished Chrome |

*Note: 1 1/4" - 2" Rough brass only and nitrile o-ring in place of gasket

APPROVALS

ASSE® 1001, ANSI® A112.1.1, CSA® B64.1.1 and IAPMO®

PERFORMANCE RATING

Maximum Operating Pressure 125 psi
 Temperature Range: 33 °F - 212 °F for 1/4" thru 1"
 Temperature Range: 33 °F - 180 °F for 1 1/4" thru 2"

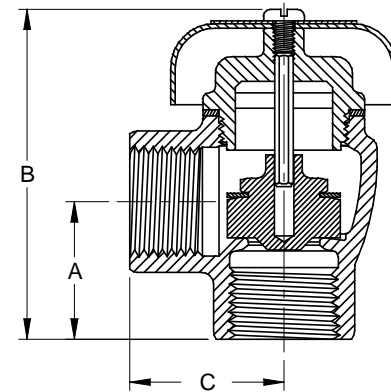

FLOW CURVES

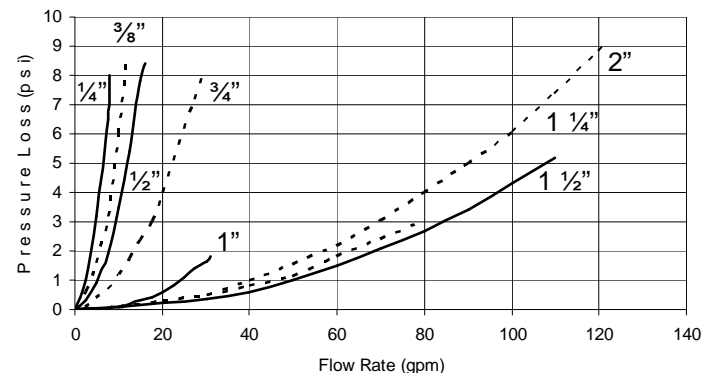

Conbraco Industries, Inc. 701 Matthews Mint Hill Rd. Matthews NC 28105 USA; www.conbraco.com; 704-841-6000

This specification is provided for reference only. Conbraco reserves the right to change any portion of this specification without notice and without incurring obligation to make such changes to Conbraco products previously or subsequently sold.