

SECTION D CONTENTS

ANSI FLANGED BALL VALVES

DESCRIPTION	PAGE(S)
Features and Benefits	D-A
Variations Available	D-B
87A-100 Series, ANSI Class 150 Flanged Stainless Steel	D-1, 2, 3, 4
87A-200 Series, ANSI Class 150 Flanged Full Port Stainless Steel	D-5, 6, 7, 8
87A-700 Series, ANSI Class 300 Flanged Stainless Steel	D-9, 10, 11, 12
87A-900 Series, ANSI Class 300 Flanged Full Port Stainless Steel	D-13, 14, 15, 16
87B-100 Series, ANSI Class 150 Flanged Uni-Body Stainless Steel	D-17, 18
88A-100 Series, ANSI Class 150 Flanged Carbon Steel	D-19, 20, 21, 22
88A-200 Series, ANSI Class 150 Flanged Full Port Carbon Steel	D-23, 24, 25, 26
88A-700 Series, ANSI Class 300 Flanged Carbon Steel	D-27, 28, 29, 30
88A-900 Series, ANSI Class 300 Flanged Full Port Carbon Steel	D-31, 32, 33, 34
88B-100 Series, ANSI Class 150 Flanged Uni-Body Carbon Steel	D-35, 36
87-100 Series, ANSI Class 150 Flanged Stainless Steel	D-37
88-100 Series, ANSI Class 150 Flanged Carbon Steel	D-38
87A-500 Series, ANSI Class 150 Flanged Full Port Alloy 20	D-39
87A-400 Series, ANSI Class 150 Flanged Alloy 20	D-40, 41, 42



ANSI Flanged Ball Valves

87A, 87B, 88A and 88B Series

Features and Benefits

STANDARDS COMPLIANCE

Except where specifically noted all valves within this family of products complies with the requirements of this listed standard.

ASME B16.5 - "Pipe Flanges and Flanged Fittings"

ASME B16.10 - "Face to Face Dimensions of Valves"

ASME B16.34 - "Valves - Flanged, Threaded, and Welding End"

ASME B16.33 - "Manual Operated Metallic Gas Valves for Use in Gas Piping Systems up to 125 psig"

ASME B16.38 - "Large Metallic Valves for Gas Distribution (Manually Operated NPS 2-1/2" to 12", 125 psig)"

ASME B31.1 - "Power Piping"

ASME B31.3 - "Chemical Plant and Petroleum Refinery Piping"

ASME B31.8 - "Gas Transmission and Distribution Piping Systems"

API 607 - "Fire Test - Soft Seated Quarter Turn Valves" (-24 Option Required)

API 608 - "Ball Valves - Flanged, Threaded, and Welding End"

MSS SP-25 - "Standard Marking System for Valves"

MSS SP-61 - "Pressure Testing of Steel Valves"

MSS SP-72 - "Ball Valves with Flanged or Buttweld Ends"

UL 125 - "Valves for Anhydrous Ammonia and LP-Gas (Other than Safety Relief)"

STANDARD FEATURES

Except where specifically noted all valves within this family of products include all listed features as standard.

Two Position Locking Device (Valves 6" FP, 8" SP and smaller)

CHV Style Adjustable Stem Seals

Four Point ISO 5211 Mounting Pad Bolt Pattern

Slot Vented Ball for Thermal Expansion

Rated 150 psig Saturated Steam

Anti-static Grounded Ball and Stem

Blow-out Proof Stem Design

Cast Boss for Bleed / Drain Port

Vacuum Service to 29 inches of Hg

NACE MR0175-2000 Compliance on all 87A/87B

PRODUCT APPROVALS

AAR Approval No. E989052 (87A-108-24, 88A-108-24 & 88A-148-24)

Approval No. E989053 (87A-100-24, 88A-100-24 & 88A-140-24)

CSA (Reference: ASME B16.33 & B16.38)

UL (Reference: Control Number 195H)

UL (YSdT) LP-Gas Shut-Off Valves

UL (MHKZ) Manual Valves

UL (YRBX) Flammable Liquid Shut-Off Valves

UL (YRPV) Gas Shut-Off Valves

UL (YQNZ) Compressed Gas Shut-Off Valves

UL (YQAR) Anhydrous Ammonia Shut-Off Valves



ANSI Flanged Ball Valves

VARIATIONS AVAILABLE:

Reference Data:				Alloy Series Flanged Ball Valves				
Size	Port	ANSI Class	Dimensional Data Page	Stainless Steel	Alloy 20	Hastelloy	Nickel	Cu-Ni
1-1/2" & 2"	Standard	150	D-1	87A-10X	87A-40X	87H-1HX	87N-1NX	87M-13X
2-1/2" & 3"	Standard	150	D-2	87A-10X	87A-40X	87H-1HX	87N-1NX	87M-13X
4", 6" & 8"	Standard	150	D-3	87A-10X	87A-40X	87H-1HX	87N-1NX	87M-13X
10"	Standard	150	D-4	87A-10X	87A-40X	87H-1HX	87N-1NX	87M-13X
1/2", 3/4" & 1"	Full	150	D-5	87A-20X	87A-50X	87H-2HX	87N-2NX	87M-23X
1-1/2", 2" & 2-1/2"	Full	150	D-6	87A-20X	87A-50X	87H-2HX	87N-2NX	87M-23X
3", 4", & 6"	Full	150	D-7	87A-20X	87A-50X	87H-2HX	87N-2NX	87M-23X
8", 10" & 12"	Full	150	D-8	87A-20X	87A-50X	87H-2HX	87N-2NX	87M-23X
1-1/2" & 2"	Standard	300	D-9	87A-70X	87A-80X	87H-7HX	87N-7NX	87M-73X
2-1/2" & 3"	Standard	300	D-10	87A-70X	87A-80X	87H-7HX	87N-7NX	87M-73X
4", 6" & 8"	Standard	300	D-11	87A-70X	87A-80X	87H-7HX	87N-7NX	87M-73X
10"	Standard	300	D-12	87A-70X	87A-80X	87H-7HX	87N-7NX	87M-73X
1/2", 3/4" & 1"	Full	300	D-13	87A-90X	87A-60X	87H-9HX	87N-9NX	87M-93X
1-1/2", 2" & 2-1/2"	Full	300	D-14	87A-90X	87A-60X	87H-9HX	87N-9NX	87M-93X
3", 4", & 6"	Full	300	D-15	87A-90X	87A-60X	87H-9HX	87N-9NX	87M-93X
8", 10" & 12"	Full	300	D-16	87A-90X	87A-60X	87H-9HX	87N-9NX	87M-93X

Alloy Material of Construction for Pressure Containing / Retaining Components					
Alloy	Stainless Steel	Alloy 20	Hastelloy	Nickel	Ni-Cu Alloy
Valves Series	87A-100/200, 87A-700/900	87A-400/500, 87A-600/800	87H-1H0/2H0, 87H-7H0/9H0	87N-1N0/2N0, 87N-7N0/9N0	87M-130/230, 87M-730/930
Body	A351-CF8M	A351-CN7M	A494-CW12MW	A494-CZ100	A494-M35-1
Retainer	A351-CF8M or A276-316	A351-CN7M or B473-N08020	A494-CW12MW or B574-C276	A494-CZ100 or B160-200	A494-M35-1 or B164-K400
Ball	A351-CF8M or A276-316	A351-CN7M or B473-N08020	A494-CW12MW or B574-C276	A494-CZ100 or B160-200	A494-M35-1 or B164-K400
Stem	A276-316	B473-N08020	B574-C276	B160-200	B164-K400
Fasteners	A193-B8M, A194-Gr8	A193-B8M, A194-Gr8	A193-B8M, A194-Gr8	A193-B8M, A194-Gr8	A193-B8M, A194-Gr8



87A-100 Series

Stainless Steel ANSI Class 150 Flanged Std. Port Ball Valve - 1-1/2" through 2"

STANDARDS COMPLIANCE

Refer to page D-A

STANDARD FEATURES

Refer to page D-A

MATERIALS OF CONSTRUCTION

Description	Material
1. Body	ASTM A351 CF8M
2. Retainer	ASTM A276 Type 316
3. Ball	ASTM A276 Type 316
4. Stem	ASTM A276 Type 316
5. Packing Gland	ASTM A276 Type 316
6. Stem Seals	PTFE
7. Seats	RPTFE
8. Gland Screws	ASTM A193 B8 Class 1
9. Gland Plate	302 or 304 SS
10. Stem Nut	316 SS
11. Lever	302 or 304 SS with Vinyl Grip
12. Stem Bearing	RPTFE
13. Stop	ASTM A276 Type 316
14. Stop Screw	18-8 SS
15. Lock Plate	302 or 304 SS
16. Body Seal	RPTFE
17. Lockwasher	302 or 304 SS
18. Grounding Spring	SS

OPTIONS AVAILABLE:

(SUFFIX)	OPTION
-01-	Standard
-14-	Side Vented Ball (Uni-Directional)
-15-	Wheel Handle, Steel
-21-	UHMWPE Seats
-24-	Fire Safe (Graphite Packing and Seal)
-35-	PTFE Seats and Seals
-38-	PEEK Seats and Graphite Packing
-49-	Assembled Dry
-57-	Oxygen Cleaned
-60-	Grounded Ball and Stem
-65-	MPTFE Seats and Graphite Packing
-67-	Cleaned For Industrial Gases
-69-	Drilled and Tapped Purge Port with Plug
-70-	4" Extended Bonnet
-73-	316 SS Spiral Wound Gaskets w/PTFE Filler
-74-	316 SS Spiral Wound Gaskets w/Graphite Filler
-76-	Live Loaded 87A/88A Series (Lever)
-80-	Multi-Seal (Super TFE) 87A/88A Series

For Pressure/Temperature Ratings, Refer to Page M-7, Graph No. 2

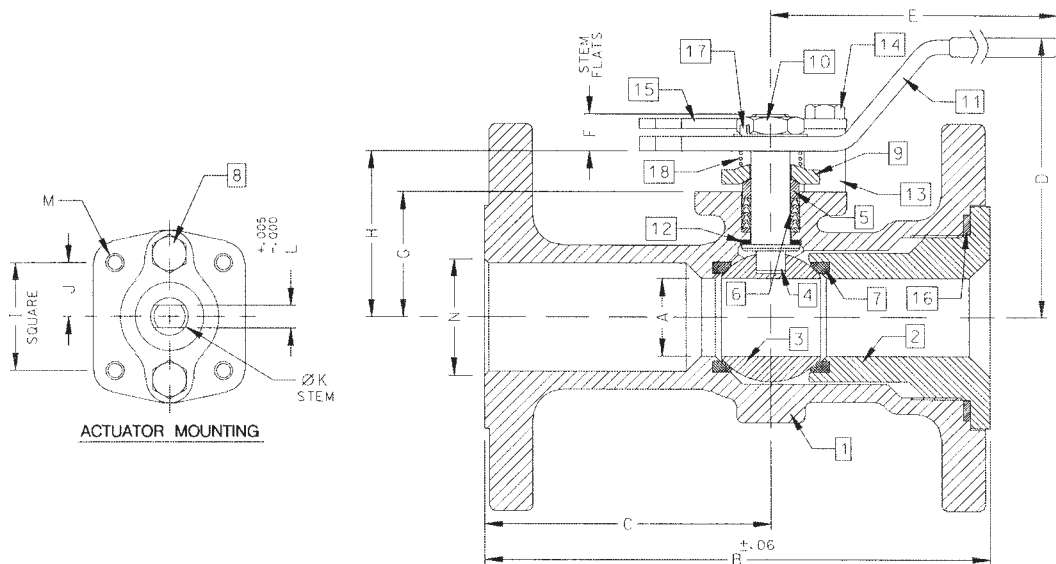

NUMBER	SIZE	A	B	C	D	E	F	G	H	I	J	K	L	M	N	WT.
87A-107-01	1-1/2"	1.25	6.50	3.50	4.85	6.53	0.47	1.85	2.38	1.392	0.696	0.500	0.287	1/4-20	1.50	9.0
87A-108-01	2"	1.50	7.00	3.69	4.62	6.65	0.72	2.41	3.09	1.949	0.974	0.625	0.412	5/16-18	2.00	18.0



87A-100 Series

Stainless Steel ANSI Class 150 Flanged Std. Port Ball Valve - 2-1/2" through 3"

STANDARDS COMPLIANCE

Refer to page D-A

STANDARD FEATURES

Refer to page D-A

MATERIALS OF CONSTRUCTION

Description	Material
1. Body	ASTM A351 CF8M
2. Retainer	ASTM A351 CF8M
3. Ball	ASTM A276 Type 316 or A351 CF8M
4. Stem	ASTM A276 Type 316
5. Packing Gland	ASTM A276 Type 316
6. Stem Seals	PTFE
7. Seats	RPTFE
8. Gland Screws	ASTM A193 B8 Class 1
9. Gland Plate	316 SS
10. Stem Nut	18-8 SS
11. Lever	316 SS
12. Stem Bearing	RPTFE
13. Stop	ASTM A276 Type 316
14. Stop Screw	316 SS
15. Lock Plate	302 or 304 SS
16. Body Seal	RPTFE
17. Grounding Spring	SS
18. Body Joint Stud	ASTM A194 Grade B8M
19. Body Joint Nut	ASTM A194 Grade 8
20. Lockwasher	302 or 304 SS

OPTIONS AVAILABLE:

(SUFFIX)	OPTION
-01-	Standard
-14-	Side Vented Ball (Uni-Directional)
-21-	UHMWPE Seats
-24-	Fire Safe (Graphite Packing and Seal)
-35-	PTFE Seats and Seals
-38-	PEEK Seats and Graphite Packing
-49-	Assembled Dry
-57-	Oxygen Cleaned
-60-	Grounded Ball and Stem
-65-	MPTFE Seats and Graphite Packing
-67-	Cleaned For Industrial Gases
-69-	Drilled and Tapped Purge Port with Plugs
-70-	4" Extended Bonnet
-73-	316 SS Spiral Wound Gaskets w/PTFE Filler
-74-	316 SS Spiral Wound Gaskets w/Graphite Filler
-76-	Live Loaded 87A/88A Series (Lever)
-80-	Multi-Seal (Super TFE) 87A/88A Series
-MG-	Gear Operator with Standard Handwheel
-MH-	Gear Operator with Standard Handwheel & Locking Device
-MJ-	Gear Operator with Oversize Handwheel
-MK-	Gear Operator with Oversize Handwheel & Locking Device

**For Pressure/Temperature Ratings,
Refer to Page M-7, Graph No. 2**

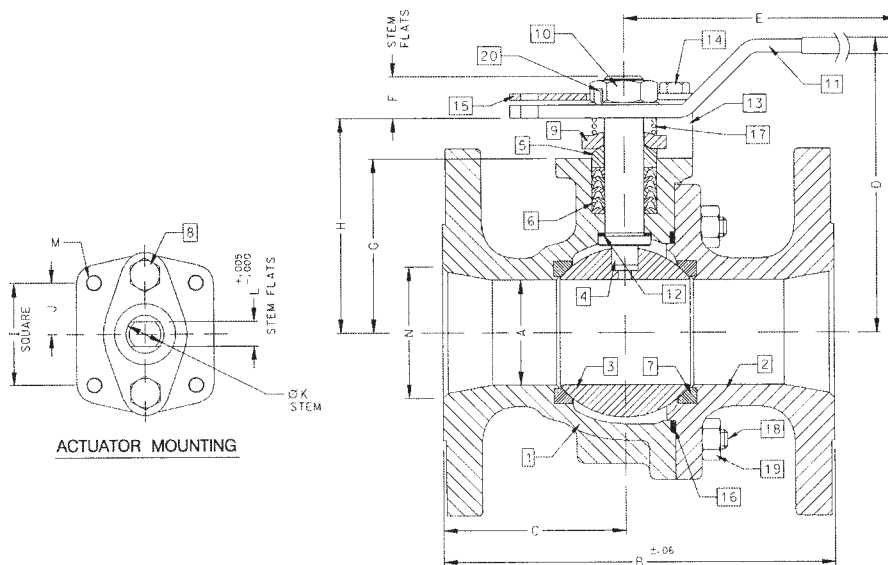

NUMBER	SIZE	A	B	C	D	E	F	G	H	I	J	K	L	M	N	WT.
87A-109-01	2-1/2"	2.00	7.50	3.50	5.61	8.41	0.80	3.31	4.08	1.949	0.974	0.750	0.477	5/16-18	2.50	27.0
87A-100-01	3"	2.50	8.00	3.51	6.24	8.41	0.80	3.94	4.71	1.949	0.974	0.750	0.477	5/16-18	3.00	34.0



87A-100 Series

Stainless Steel ANSI Class 150 Flanged Std. Port Ball Valve - 4" through 8"

STANDARDS COMPLIANCE

Refer to page D-A

STANDARD FEATURES

Refer to page D-A

MATERIALS OF CONSTRUCTION

Description	Material
1. Body	ASTM A351 CF8M
2. Retainer	ASTM A351 CF8M
3. Ball	ASTM A276 Type 316 or A351 CF8M
4. Stem	ASTM A276 Type 316
5. Packing Gland	ASTM A276 Type 316
6. Stem Seals	PTFE
7. Seats	RPTFE
8. Gland Screws	ASTM A193 B8 Class 1
9. Gland Plate	316 SS
10. Adapter Screw	18-8 SS
11. Handle Adapter	316 SS
12. Stem Bearing	RPTFE
13. Stop	ASTM A276 Type 316
14. Stop Screw	316 SS
15. Lock Plate	302 or 304 SS
16. Body Seal	RPTFE
17. Grounding Spring	SS
18. Body Joint Stud	ASTM A194 Grade B8M
19. Body Joint Nut	ASTM A194 Grade 8
20. Lockwasher	302 or 304 SS
21. Pipe Handle	Galvanized Steel (not Shown)

OPTIONS AVAILABLE:

(SUFFIX)	OPTION
-01-	Standard
-14-	Side Vented Ball (Uni-Directional)
-21-	UHMWPE Seats
-24-	Fire Safe (Graphite Packing and Seal)
-35-	PTFE Seats and Seals
-49-	Assembled Dry
-57-	Oxygen Cleaned
-60-	Grounded Ball and Stem
-65-	MPTFE Seats and Graphite Packing
-67-	Cleaned For Industrial Gases
-69-	Drilled and Tapped Purge Ports with Plugs
-70-	Extended Bonnet
-73-	316 SS Spiral Wound Gaskets w/PTFE Filler
-74-	316 SS Spiral Wound Gaskets w/Graphite Filler
-76-	Live Loaded 87A/88A Series (Lever)
-80-	Multi-Seal (Super TFE) 87A/88A Series
-MG-	Gear Operator with Standard Handwheel
-MH-	Gear Operator with Standard Handwheel & Locking Device
-MJ-	Gear Operator with Oversize Handwheel
-MK-	Gear Operator with Oversize Handwheel & Locking Device

For Pressure/Temperature Ratings, Refer to Page M-7, Graph No. 2

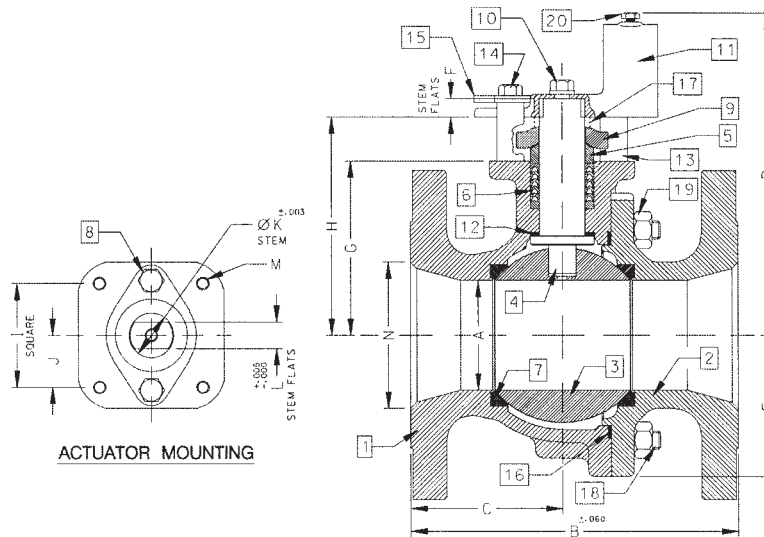

NUMBER	SIZE	A	B	C	D	E	F	G	H	I	J	K	L	M	N	WT.
87A-10A-01	4"	3.00	9.00	4.18	8.80	3.88	0.50	4.75	5.95	2.840	1.420	1.250	0.725	3/8-16	4.00	73.0
87A-10C-01	6"	4.00	10.50	4.69	9.99	5.13	0.50	5.94	7.13	2.840	1.420	1.250	0.725	3/8-16	6.00	117.0
87A-10E-01	8"	6.00	18.00	9.00	13.73	7.00	1.00	7.75	9.48	4.596	2.298	2.000	1.375	3/4-10	8.00	310.0



87A-100 Series

Stainless Steel ANSI Class 150 Flanged Std. Port Ball Valve - 10"

STANDARDS COMPLIANCE

Refer to page D-A

STANDARD FEATURES

Refer to page D-A

MATERIALS OF CONSTRUCTION

Description	Material
1. Body	ASTM A351 CF8M
2. Retainer	ASTM A351 CF8M
3. Ball	ASTM A276 Type 316 or A351 CF8M
4. Stem	ASTM A276 Type 316
5. Packing Gland	ASTM A276 Type 316
6. Stem Seals	PTFE
7. Seats	RPTFE
8. Gland Screws	ASTM A193 B8 Class 1
9. Gland Plate	316 SS
10. Stem Bearing	RPTFE
11. Body Seal	RPTFE
12. Body Joint Stud	ASTM A193 Grade B8M
13. Body Joint Nut	ASTM A194 Grade 8

OPTIONS AVAILABLE:

(SUFFIX)	OPTION
-01-	Standard
-14-	Side Vented Ball (Uni-Directional)
-21-	UHMWPE Seats
-24-	Fire Safe (Graphite Packing and Seal)
-35-	PTFE Seats and Seals
-49-	Assembled Dry
-57-	Oxygen Cleaned
-60-	Grounded Ball and Stem
-65-	MPTFE Seats and Graphite Packing
-69-	Drilled and Tapped Purge Port with Plugs
-70-	Extended Bonnet
-76-	Live Loaded 87A/88A Series (Lever)
-80-	Multi-Seal (Super TFE) 87A/88A Series
-MG-	Gear Operator with Standard Handwheel
-MH-	Gear Operator with Standard Handwheel & Locking Device
-MJ-	Gear Operator with Oversize Handwheel
-MK-	Gear Operator with Oversize Handwheel & Locking Device

**For Pressure/Temperature Ratings,
Refer to Page M-7, Graph No. 2**

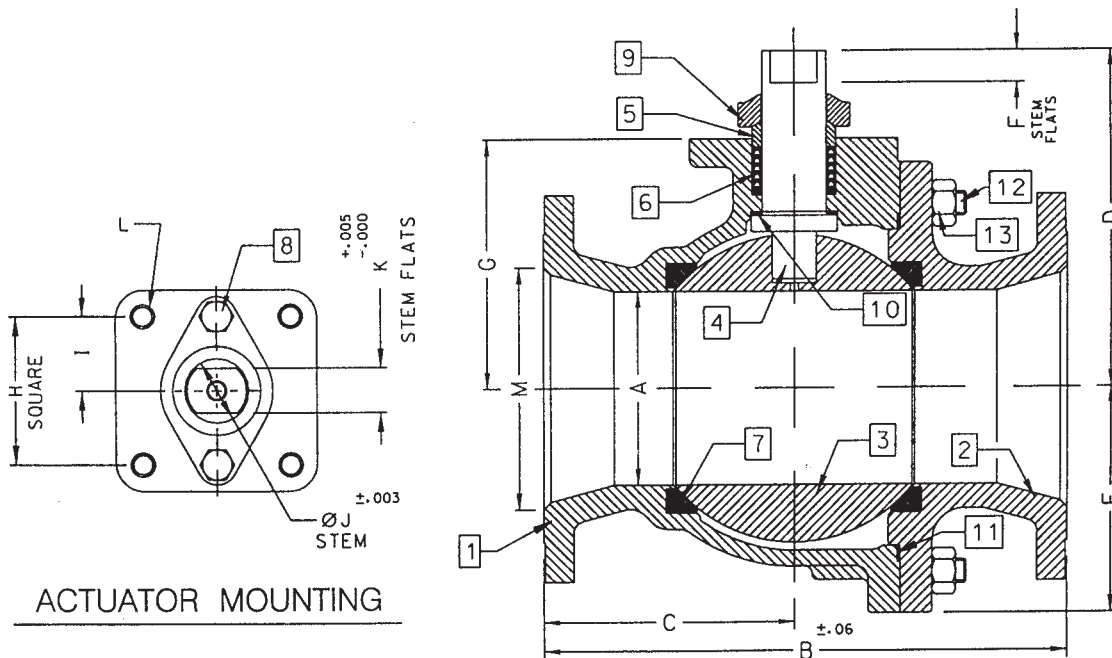

NUMBER	SIZE	A	B	C	D	E	F	G	H	I	J	K	L	M
87A-10G-01	10"	8.00	21.00	10.37	12.83	9.18	1.00	10.22	4.596	2.298	2.000	1.375	3/4-10	10.00



87A-200 Series

Stainless Steel ANSI Class 150 Flanged Full Port Ball Valve - 1/2" through 1"

STANDARDS COMPLIANCE

Refer to page D-A

STANDARD FEATURES

Refer to page D-A

MATERIALS OF CONSTRUCTION

Description (1/2" & 3/4" Valves)	Material
1. Body	ASTM A351 CF8M
2. Retainer	ASTM A276 Type 316
3. Ball	ASTM A276 Type 316
4. Stem	ASTM A276 Type 316
5. Packing Gland	ASTM A276 Type 316
6. Stem Seals	PTFE
7. Seats	RPTFE
8. Stem Nut	300 Series Stainless Steel
9. Lever	300 Series Stainless Steel w/ Vinyl Grip
10. Stem Bearing	RPTFE
11. Stop	300 Series Stainless Steel
12. Body Seal	RPTFE
13. Lockwasher	300 Series Stainless Steel
14. Grounding Spring	ASTM A313 Stainless Steel
15. Grounding Spring	ASTM A313 Stainless Steel

Description (1" Valves)	Material
1. Body	ASTM A351 CF8M
2. Retainer	ASTM A276 Type 316
3. Ball	ASTM A276 Type 316
4. Stem	ASTM A276 Type 316
5. Packing Gland	ASTM A276 Type 316
6. Stem Seals	PTFE
7. Seats	RPTFE
8. Gland Screws	ASTM A193 B8 Class 1
9. Gland Plate	302 or 304 SS
10. Stem Nut	316 SS
11. Lever	302 or 304 with Vinyl Grip
12. Stem Bearing	RPTFE
13. Stop	ASTM A276 Type 316
14. Stop Screw	18-8 SS
15. Lock Plate	302 or 304 SS
16. Body Seal	RPTFE
17. Lockwasher	302 or 304 SS
18. Grounding Spring	SS

OPTIONS AVAILABLE:

(SUFFIX)	OPTION
-01-	Standard
-14-	Side Vented Ball (Uni-Directional)
-15-	Wheel Handle, Steel
-21-	UHMWPE Seats
-24-	Fire Safe (Graphite Packing and Seal)
-35-	PTFE Seats and Seals
-38-	PEEK Seats and Graphite Packing
-49-	Assembled Dry
-57-	Oxygen Cleaned
-60-	Grounded Ball and Stem
-65-	MPTFE Seats and Graphite Packing
-67-	Cleaned For Industrial Gases
-69-	Drilled and Tapped Purge Port with Plugs
-70-	4" Extended Bonnet - N/A in 1/2" and 3/4"
-73-	316 SS Spiral Wound Gaskets w/PTFE Filler
-74-	316 SS Spiral Wound Gaskets w/Graphite Filler
-80-	Multi-Seal (Super TFE) 87A/88A Series

For Pressure/Temperature Ratings, Refer to Page M-7, Graph No. 2

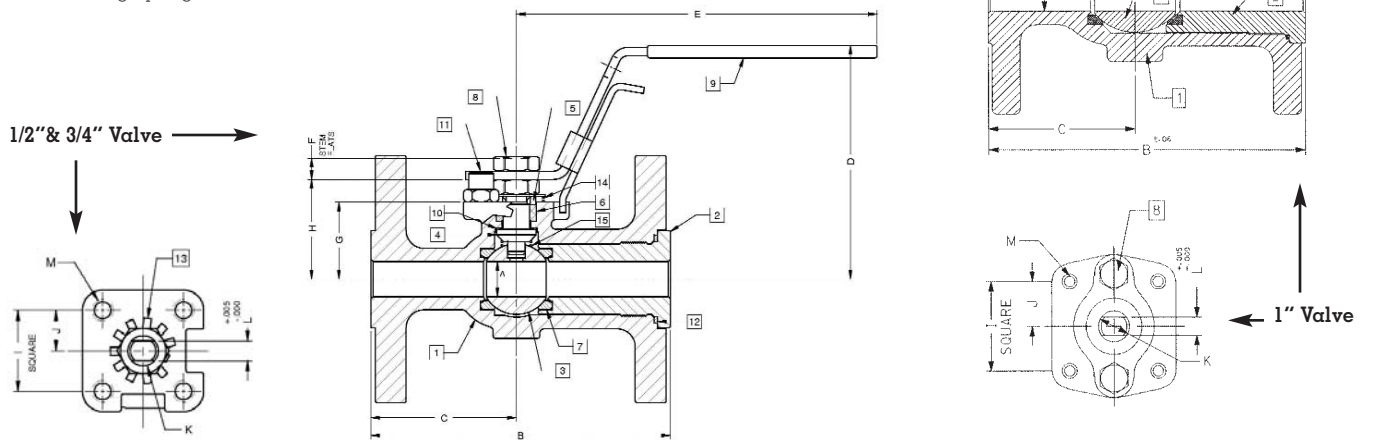

NUMBER	SIZE	A	B	C	D	E	F	G	H	I	J	K	L	M	WT.
87A-203-01	1/2"	0.50	4.25	2.06	3.31	5.11	.30	1.09	1.41	1.00	.500	.375	.245	10-24	5.0
87A-204-01	3/4"	0.75	4.62	2.18	3.89	5.53	.36	1.65	1.99	1.392	.696	.500	.287	1/4-20	6.0
87A-205-01	1"	1.00	5.00	2.32	4.62	6.53	0.47	1.62	2.15	1.392	0.696	0.500	0.287	1/4-20	7.0



87A-200 Series

Stainless Steel ANSI Class 150 Flanged Full Port Ball Valve - 1-1/2" through 2-1/2"

STANDARDS COMPLIANCE

Refer to page D-A

STANDARD FEATURES

Refer to page D-A

MATERIALS OF CONSTRUCTION

Description	Material
1. Body	ASTM A351 CF8M
2. Retainer	ASTM A351 CF8M
3. Ball	ASTM A276 Type 316 or A351 CF8M
4. Stem	ASTM A276 Type 316
5. Packing Gland	ASTM A276 Type 316
6. Stem Seals	PTFE
7. Seats	RPTFE
8. Gland Screws	ASTM A193 B8 Class 1
9. Gland Plate	316 SS
10. Adapter Screw	18-8 SS
11. Lever	316 SS
12. Stem Bearing	RPTFE
13. Stop	ASTM A276 Type 316
14. Stop Screw	316 SS
15. Lock Plate	302 or 304 SS
16. Body Seal	RPTFE
17. Grounding Spring	SS
18. Body Joint Stud	ASTM A193 Grade B8M
19. Body Joint Nut	ASTM A194 Grade 8
20. Lockwasher	302 or 304 SS

OPTIONS AVAILABLE:

(SUFFIX)	OPTION
-01-	Standard
-14-	Side Vented Ball (Uni-Directional)
-21-	UHMWPE Seats
-24-	Fire Safe (Graphite Packing and Seal)
-35-	PTFE Seats and Seals
-38-	PEEK Seats and Graphite Packing (3" Only)
-49-	Assembled Dry
-57-	Oxygen Cleaned
-60-	Grounded Ball and Stem
-65-	MPTFE Seats and Graphite Packing
-67-	Cleaned For Industrial Gases
-69-	Drilled and Tapped Purge Ports with Plugs
-70-	4" Extended Bonnet
-73-	316 SS Spiral Wound Gaskets w/PTFE Filler
-74-	316 SS Spiral Wound Gaskets w/Graphite Filler
-80-	Multi-Seal (Super TFE) 87A/88A Series
-MG-	Gear Operator with Standard Handwheel
-MH-	Gear Operator with Standard Handwheel & Locking Device
-MJ-	Gear Operator with Oversize Handwheel
-MK-	Gear Operator with Oversize Handwheel & Locking Device

For Pressure/Temperature Ratings, Refer to Page M-7, Graph No. 2

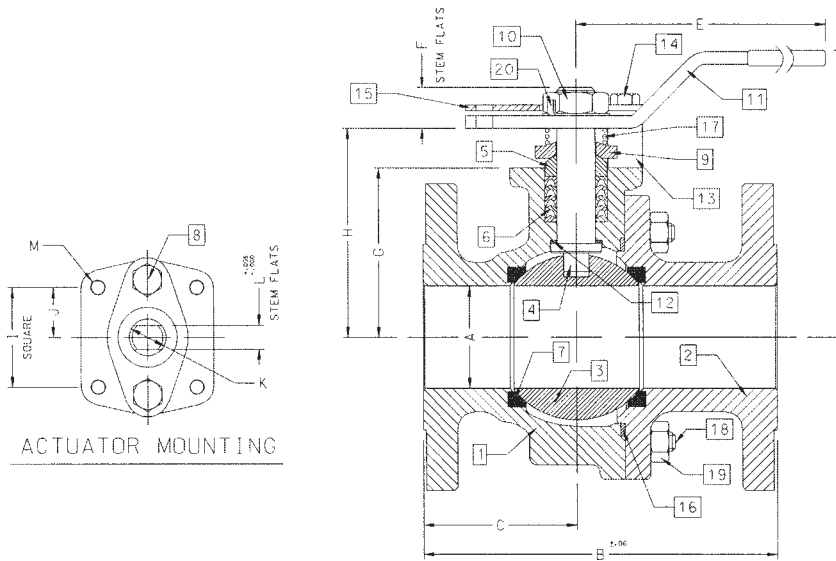

NUMBER	SIZE	A	B	C	D	E	F	G	H	I	J	K	L	M	WT.
87A-207-01	1-1/2"	1.50	6.50	3.00	4.62	6.65	0.72	2.41	3.09	1.949	0.974	0.625	0.412	5/16-18	14.0
87A-208-01	2"	2.00	7.00	3.04	5.61	8.41	0.80	3.31	4.08	1.949	0.974	0.750	0.477	5/16-18	25.0
87A-209-01	2-1/2"	2.50	7.50	3.34	6.24	8.41	0.80	3.94	4.71	1.949	0.974	0.750	0.477	5/16-18	30.0



87A-200 Series

Stainless Steel ANSI Class 150 Flanged Full Port Ball Valve - 3" through 6"

STANDARDS COMPLIANCE

Refer to page D-A

STANDARD FEATURES

Refer to page D-A

MATERIALS OF CONSTRUCTION

Description	Material
1. Body	ASTM A351 CF8M
2. Retainer	ASTM A351 CF8M
3. Ball	ASTM A276 Type 316 or A351 CF8M
4. Stem	ASTM A276 Type 316
5. Packing Gland	ASTM A276 Type 316
6. Stem Seals	PTFE
7. Seats	RPTFE
8. Gland Screws	ASTM A193 B8 Class 1
9. Gland Plate	316 SS
10. Adapter Screw	18-8 SS
11. Handle Adapter	316 with Vinyl Grip
12. Stem Bearing	RPTFE
13. Stop	ASTM A276 Type 316
14. Stop Screw	316 SS
15. Lock Plate	302 or 304 SS
16. Body Seal	RPTFE
17. Grounding Spring	SS
18. Body Joint Stud	ASTM A193 Grade B8M
19. Body Joint Nut	ASTM A194 Grade 8
20. Pipe Handle	Galvanized Steel (not shown)

OPTIONS AVAILABLE:

(SUFFIX)	OPTION
-01-	Standard
-14-	Side Vented Ball (Uni-Directional)
-21-	UHMWPE Seats
-24-	Fire Safe (Graphite Packing and Seal)
-35-	PTFE Seats and Seals
-38-	PEEK Seats and Graphite Packing (3" Only)
-49-	Assembled Dry
-57-	Oxygen Cleaned
-60-	Grounded Ball and Stem
-65-	MPTFE Seats and Graphite Packing
-67-	Cleaned For Industrial Gases
-69-	Drilled and Tapped Purge Ports with Plugs
-70-	Extended Bonnet
-73-	316 SS Spiral Wound Gaskets w/PTFE Filler
-74-	316 SS Spiral Wound Gaskets w/Graphite Filler
-76-	Live Loaded 87A/88A Series (Lever)
-80-	Multi-Seal (Super TFE) 87A/88A Series
-MG-	Gear Operator with Standard Handwheel
-MH-	Gear Operator with Standard Handwheel & Locking Device
-MJ-	Gear Operator with Oversize Handwheel
-MK-	Gear Operator with Oversize Handwheel & Locking Device

For Pressure/Temperature Ratings, Refer to Page M-7, Graph No. 2

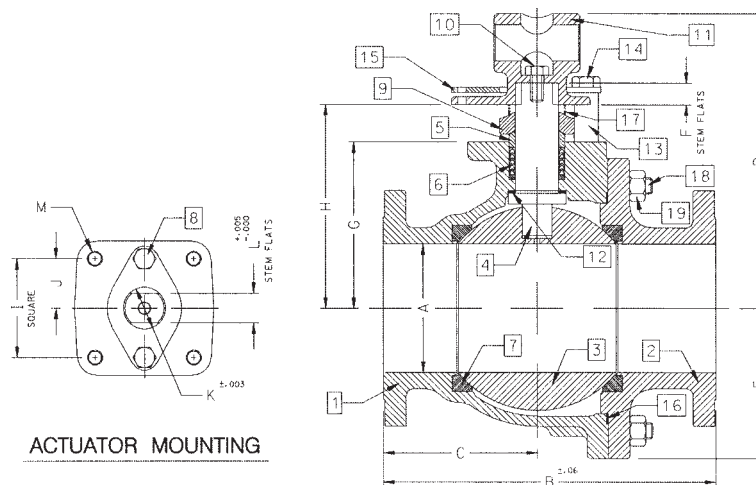

NUMBER	SIZE	A	B	C	D	E	F	G	H	I	J	K	L	M	WT.
87A-200-01	3"	3.00	8.00	3.68	8.80	3.88	0.50	4.75	5.95	2.840	1.420	1.250	0.725	3/8-16	60.0
87A-20A-01	4"	4.00	9.00	3.94	9.99	5.13	0.50	5.94	7.13	2.840	1.420	1.250	0.725	3/8-16	91.0
87A-20C-01	6"	6.00	15.50	7.19	13.73	7.00	1.00	7.75	9.48	4.596	2.298	2.000	1.375	3/4-10	248.0



87A-200 Series

Stainless Steel ANSI Class 150 Flanged Full Port Ball Valve - 8" through 12"

STANDARDS COMPLIANCE

Refer to page D-A

STANDARD FEATURES

Refer to page D-A

MATERIALS OF CONSTRUCTION

Description	Material
1. Body	ASTM A351 CF8M
2. Retainer	ASTM A351 CF8M
3. Ball	ASTM A276 Type 316 or A351 CF8M
4. Stem	ASTM A276 Type 316
5. Packing Gland	ASTM A276 Type 316
6. Stem Seals	PTFE
7. Seats	RPTFE
8. Gland Screws	ASTM A193 B8 Class 1
9. Gland Plate	316 SS
10. Stem Bearing	RPTFE
11. Body Seal	RPTFE
12. Body Joint Stud	ASTM A193 Grade B8M
13. Body Joint Nut	ASTM A194 Grade 8

OPTIONS AVAILABLE:

(SUFFIX)	OPTION
-01-	Standard
-14-	Side Vented Ball (Uni-Directional)
-21-	UHMWPE Seats
-24-	Fire Safe (Graphite Packing and Seal)
-35-	PTFE Seats and Seals
-49-	Assembled Dry
-57-	Oxygen Cleaned
-60-	Grounded Ball and Stem
-65-	MPTFE Seats and Graphite Packing
-69-	Drilled and Tapped Purge Ports with Plugs
-70-	Extended Bonnet (8" Only)
-76-	Live Loaded 87A/88A Series (Lever)
-80-	Multi-Seal (Super TFE) 87A/88A Series
-MG-	Gear Operator with Standard Handwheel
-MH-	Gear Operator with Standard Handwheel & Locking Device
-MJ-	Gear Operator with Oversize Handwheel
-MK-	Gear Operator with Oversize Handwheel & Locking Device

For Pressure/Temperature Ratings, Refer to Page M-7, Graph No. 2

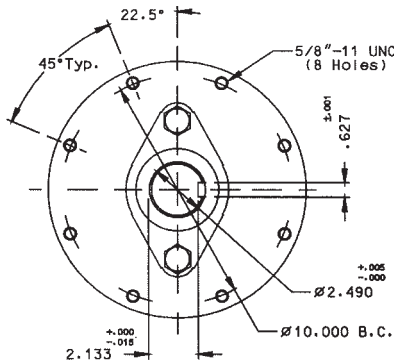

ACTUATOR MOUNTING: 10" & 12"

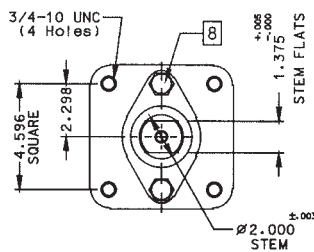

ACTUATOR MOUNTING: 8"

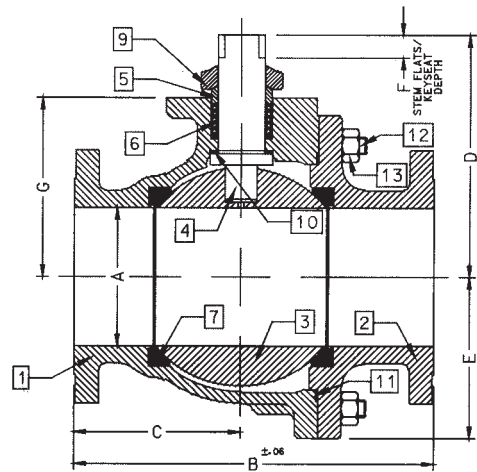

NUMBER	SIZE	A	B	C	D	E	F	G
87A-20E-01	8"	8.00	18.00	8.88	12.83	9.18	1.00	10.22
87A-20G-01	10"	10.00	21.00	10.26	18.57	11.33	2.31	12.80
87A-20H-01	12"	12.00	24.00	12.09	20.31	13.40	2.31	14.92



87A-700 Series

Stainless Steel ANSI Class 300 Flanged Std. Port Ball Valve - 1-1/2" through 2"

STANDARDS COMPLIANCE

Refer to page D-A

STANDARD FEATURES

Refer to page D-A

MATERIALS OF CONSTRUCTION

Description	Material
1. Body	ASTM A351 CF8M
2. Retainer	ASTM A276 Type 316
3. Ball	ASTM A276 Type 316
4. Stem	ASTM A276 Type 316
5. Packing Gland	ASTM A276 Type 316
6. Stem Seals	PTFE
7. Seats	RPTFE
8. Gland Screws	ASTM A193 B8 Class 1
9. Gland Plate	302 & 304 SS
10. Stem Nut	316 SS
11. Lever	302 & 304 SS with Vinyl Grip
12. Stem Bearing	RPTFE
13. Stop	ASTM A276 Type 316
14. Stop Screw	18-8 SS
15. Lock Plate	302 or 304 SS
16. Body Seal	RPTFE
17. Lockwasher	302 or 304 SS
18. Grounding Spring	SS

OPTIONS AVAILABLE:

(SUFFIX)	OPTION
-01-	Standard
-14 -	Side Vented Ball (See Page J-2)
-15-	Wheel Handle, Steel
-21 -	UHMWPE Seats
-24 -	Fire Safe (Graphite Packing and Seal)
-35 -	PTFE Seats and Seals
-38-	PEEK Seats and Graphite Packing
-49-	Assembled Dry
-57-	Oxygen Cleaned
-60-	Grounded Ball and Stem
-65-	MPTFE Seats and Graphite Packing
-67-	Cleaned For Industrial Gases
-69-	Drilled and Tapped Purge Ports with Plugs
-70-	4" Extended Bonnet
-73-	316 SS Spiral Wound Gaskets w/PTFE Filler
-74-	316 SS Spiral Wound Gaskets w/Graphite Filler
-76-	Live Loaded 87A/88A Series (Lever)
-80-	Multi-Seal (Super TFE) 87A/88A Series

**For Pressure/Temperature Ratings,
Refer to Page M-9, Graph No. 6**

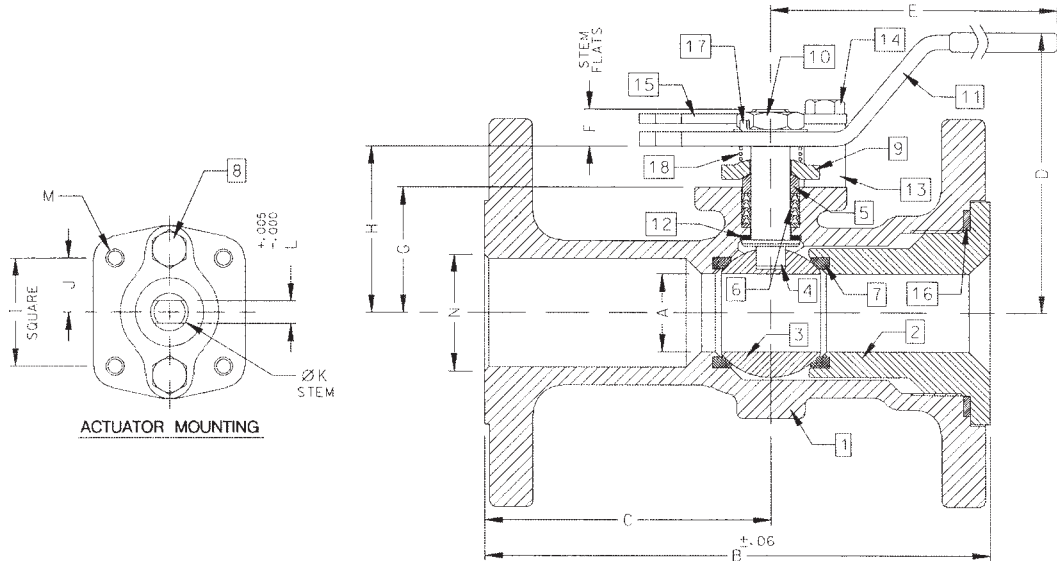

NUMBER	SIZE	A	B	C	D	E	F	G	H	I	J	K	L	M	N	WT.
87A-707-01A	1-1/2"	1.25	7.50	4.50	4.85	6.53	0.47	1.85	2.38	1.392	0.696	0.500	0.287	1/4-20	1.50	15.7
87A-708-01	2"	1.50	8.50	5.19	4.62	6.65	0.72	2.41	3.09	1.949	0.974	0.625	0.412	5/16-18	2.00	24.0



87A-700 Series

Stainless Steel ANSI Class 300 Flanged Std. Port Ball Valve - 2-1/2" through 3"

STANDARDS COMPLIANCE

Refer to page D-A

STANDARD FEATURES

Refer to page D-A

MATERIALS OF CONSTRUCTION

Description	Material
1. Body	ASTM A351 CF8M
2. Retainer	ASTM A351 CF8M
3. Ball	ASTM A276 Type 316 or A351 CF8M
4. Stem	ASTM A276 Type 316
5. Packing Gland	ASTM A276 Type 316
6. Stem Seals	PTFE
7. Seats	RPTFE
8. Gland Screws	ASTM A193 B8 Class 1
9. Gland Plate	316 SS
10. Stem Nut	18-8 SS
11. Lever	316 with Vinyl Grip
12. Stem Bearing	RPTFE
13. Stop	ASTM A276 Type 316
14. Stop Screw	316 SS
15. Lock Plate	302 or 304 SS
16. Body Seal	RPTFE
17. Grounding Spring	SS
18. Body Joint Stud	ASTM A193 Grade B8M
19. Body Joint Nut	ASTM A194 Grade 8
20. Lockwasher	302 or 304 SS

OPTIONS AVAILABLE:

(SUFFIX)	OPTION
-01-	Standard
-14-	Side Vented Ball (Uni-Directional)
-21-	UHMWPE Seats
-24-	Fire Safe (Graphite Packing and Seal)
-35-	PTFE Seats and Seals
-38-	PEEK Seats and Graphite Packing
-49-	Assembled Dry
-57-	Oxygen Cleaned
-60-	Grounded Ball and Stem
-65-	MPTFE Seats and Graphite Packing
-67-	Cleaned For Industrial Gases
-69-	Drilled and Tapped Purge Ports with Plugs
-70-	4" Extended Bonnet
-73-	316 SS Spiral Wound Gaskets w/PTFE Filler
-74-	316 SS Spiral Wound Gaskets w/Graphite Filler
-76-	Live Loaded 87A/88A Series (Lever)
-80-	Multi-Seal (Super TFE) 87A/88A Series
-MG-	Gear Operator with Standard Handwheel
-MH-	Gear Operator with Standard Handwheel & Locking Device
-MJ-	Gear Operator with Oversize Handwheel
-MK-	Gear Operator with Oversize Handwheel & Locking Device

For Pressure/Temperature Ratings, Refer to Page M-9, Graph No. 6

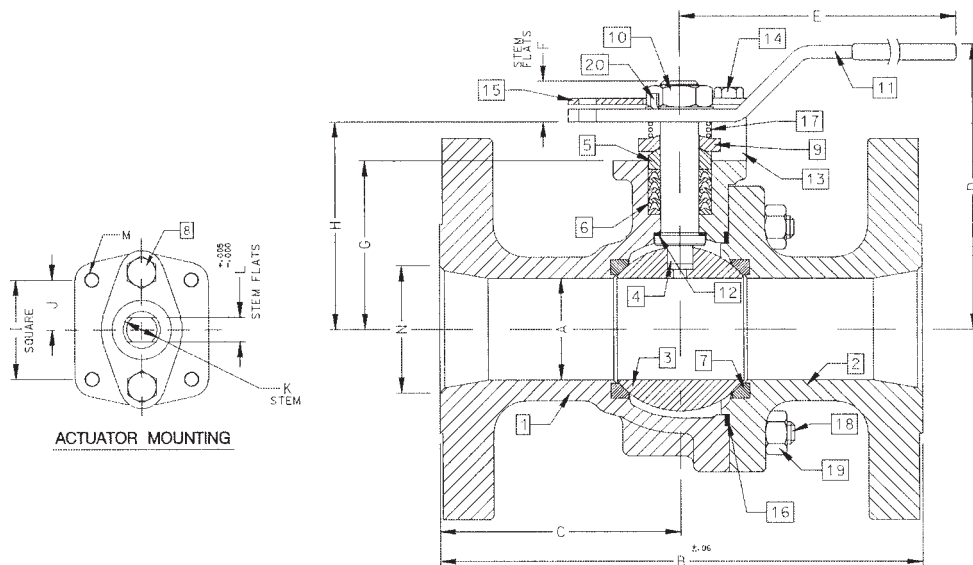

NUMBER	SIZE	A	B	C	D	E	F	G	H	I	J	K	L	M	N	WT.
87A-709-01	2-1/2"	2.00	9.50	4.75	5.61	8.41	0.80	3.31	4.08	1.949	0.974	0.750	0.477	5/16-18	2.50	39.0
87A-700-01	3"	2.50	11.12	5.56	6.24	8.41	0.80	3.94	4.71	1.949	0.974	0.750	0.477	5/16-18	3.00	55.0



87A-700 Series

Stainless Steel ANSI Class 300 Flanged Std. Port Ball Valve - 4" through 8"

STANDARDS COMPLIANCE

Refer to page D-A

STANDARD FEATURES

Refer to page D-A

MATERIALS OF CONSTRUCTION

Description	Material
1. Body	ASTM A351 CF8M
2. Retainer	ASTM A276 Type 316
3. Ball	ASTM A276 Type 316 or A351 CF8M
4. Stem	ASTM A276 Type 316
5. Packing Gland	ASTM A276 Type 316
6. Stem Seals	PTFE
7. Seats	RPTFE
8. Gland Screws	ASTM A193 B8 Class 1
9. Gland Plate	316 SS
10. Adapter Screw	18-8 SS
11. Handle Adapter	316 SS
12. Stem Bearing	RPTFE
13. Stop	ASTM A276 Type 316
14. Stop Screw	316 SS
15. Lock Plate	302 or 304 SS
16. Body Seal	RPTFE
17. Grounding Spring	SS
18. Body Joint Stud	ASTM A193 Grade B8M
19. Body Joint Nut	ASTM A194 Grade 8
20. Adapter Screw	18-8 SS
21. Pipe Handle	Galvanized Steel (not shown)

OPTIONS AVAILABLE:

(SUFFIX)	OPTION
-01-	Standard
-14-	Side Vented Ball (Uni-Directional)
-21-	UHMWPE Seats
-24-	Fire Safe (Graphite Packing and Seal)
-35-	PTFE Seats and Seals
-49-	Assembled Dry
-57-	Oxygen Cleaned
-60-	Grounded Ball and Stem
-65-	MPTFE Seats and Graphite Packing
-67-	Cleaned For Industrial Gases
-69-	Drilled and Tapped Purge Ports with Plugs
-70-	Extended Bonnet
-73-	316 SS Spiral Wound Gaskets w/PTFE Filler
-74-	316 SS Spiral Wound Gaskets w/Graphite Filler
-76-	Live Loaded 87A/88A Series (Lever)
-80-	Multi-Seal (Super TFE) 87A/88A Series
-MG-	Gear Operator with Standard Handwheel
-MH-	Gear Operator with Standard Handwheel & Locking Device
-MJ-	Gear Operator with Oversize Handwheel
-MK-	Gear Operator with Oversize Handwheel & Locking Device

For Pressure/Temperature Ratings, Refer to Page M-9, Graph No. 6

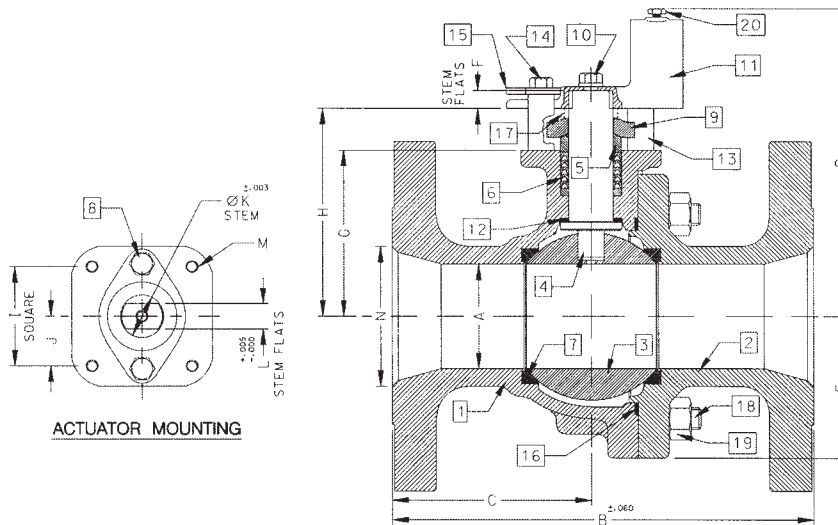

NUMBER	SIZE	A	B	C	D	E	F	G	H	I	J	K	L	M	N	WT.
87A-70A-01	4"	3.00	12.00	5.68	8.80	4.06	0.50	4.75	5.95	2.840	1.420	1.250	0.725	3/8-16	4.00	95.0
87A-70C-01	6"	4.00	15.88	7.38	9.99	5.25	0.50	5.94	7.13	2.840	1.420	1.250	0.725	3/8-16	6.00	187.0
87A-70E-01	8"	6.00	19.75	9.00	13.73	7.30	1.00	7.75	9.48	4.596	2.298	2.000	1.375	3/4-10	8.00	400.0



87A-700 Series

Stainless Steel ANSI Class 300 Flanged Standard Port Ball Valve - 10"

STANDARDS COMPLIANCE

Refer to page D-A

STANDARD FEATURES

Refer to page D-A

MATERIALS OF CONSTRUCTION

Description	Material
1. Body	ASTM A351 CF8M
2. Retainer	ASTM A351 CF8M
3. Ball	ASTM A276 Type 316 or A351 CF8M
4. Stem	ASTM A276 Type 316
5. Packing Gland	ASTM A276 Type 316
6. Stem Seals	PTFE
7. Seats	RPTFE
8. Gland Screws	ASTM A193 B8 Class 1
9. Gland Plate	316 SS
10. Stem Bearing	RPTFE
11. Body Seal	RPTFE
12. Body Joint Stud	ASTM A193 Grade B8M
13. Body Joint Nut	ASTM A194 Grade 8

OPTIONS AVAILABLE:

(SUFFIX)	OPTION
-01-	Standard (Less Gear Operator)
-14-	Side Vented Ball (See Page J2)
-21-	UHMWPE Seats
-24-	Fire Safe (Graphite Packing and Seal)
-35-	PTFE Seats and Seals
-49-	Assembled Dry
-57-	Oxygen Cleaned (Stainless Steel Valves Only)
-60-	Grounded Ball and Stem
-65-	MPTFE Seats and Graphite Packing
-69-	Drilled and Tapped Purge Ports with Plugs
-70-	Extended Bonnet
-76-	Live Loaded 87A/88A Series (Lever)
-77-	Live Loaded 87A/88A Series (Gear & Actuated)
-80-	Multi-Seal (Super TFE) 87A/88A Series
-MG-	Gear Operator with Standard Handwheel
-MH-	Gear Operator with Standard Handwheel & Locking Device
-MJ-	Gear Operator with Oversize Handwheel
-MK-	Gear Operator with Oversize Handwheel & Locking Device

**For Pressure/Temperature Ratings,
Refer to Page M-9, Graph No. 6**

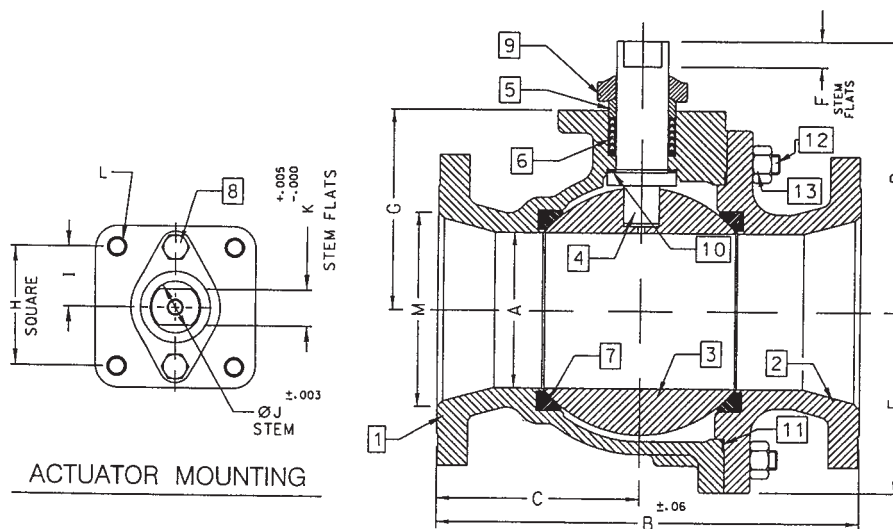

NUMBER	SIZE	A	B	C	D	E	F	G	H	I	J	K	L	M
87A-70G-01	10"	8.00	22.38	10.69	12.83	9.56	1.00	10.22	4.596	2.298	2.000	1.375	3/4-10	10.00



87A-900 Series

Stainless Steel ANSI Class 300 Flanged Full Port Ball Valve - 1/2" through 1"

STANDARDS COMPLIANCE

Refer to page D-A

STANDARD FEATURES

Refer to page D-A

MATERIALS OF CONSTRUCTION

Description (1/2" & 3/4" Valves)	Material
1. Body	ASTM A351 CF8M
2. Retainer	ASTM A276 Type 316
3. Ball	ASTM A276 Type 316
4. Stem	ASTM A276 Type 316
5. Packing Gland	ASTM A276 Type 316
6. Stem Seals	PTFE
7. Seats	RPTFE
8. Stem Nut	300 Series Stainless Steel
9. Lever	300 Series Stainless Steel
10. Stem Bearing	RPTFE
11. Stop	300 Series Stainless Steel
12. Body Seal	RPTFE
13. Lockwasher	300 Series Stainless Steel
14. Grounding Spring	ASTM A313 Stainless Steel
15. Grounding Spring	ASTM A313 Stainless Steel

Description (1" Valves)	Material
1. Body	ASTM A351 CF8M
2. Retainer	ASTM A276 Type 316
3. Ball	ASTM A276 Type 316
4. Stem	ASTM A276 Type 316
5. Packing Gland	ASTM A276 Type 316
6. Stem Seals	PTFE
7. Seats	RPTFE
8. Gland Screws	ASTM A193 B8 Class 1
9. Gland Plate	302 or 304 SS
10. Stem Nut	316 SS
11. Lever	302 or 304 with Vinyl Grip
12. Stem Bearing	RPTFE
13. Stop	ASTM A276 Type 316
14. Stop Screw	18-8 SS
15. Lock Plate	302 or 304 SS
16. Body Seal	RPTFE
17. Lockwasher	302 or 304 SS
18. Grounding Spring	SS

OPTIONS AVAILABLE:

(SUFFIX)	OPTION
-01-	Standard
-14-	Side Vented Ball (Uni-Directional)
-15-	Wheel Handle, Steel
-21-	UHMWPE Seats
-24-	Fire Safe (Graphite Packing and Seal)
-35-	PTFE Seats and Seals
-38-	PEEK Seats and Graphite Packing
-49-	Assembled Dry
-57-	Oxygen Cleaned
-60-	Grounded Ball and Stem
-65-	MPTFE Seats and Graphite Packing
-67-	Cleaned For Industrial Gases
-69-	Drilled and Tapped Purge Port with Plugs
-70-	4" Extended Bonnet
-73-	316 SS Spiral Wound Gaskets w/PTFE Filler
-74-	316 SS Spiral Wound Gaskets w/Graphite Filler
-76-	Live Loaded 87A/88A Series (Lever)
-80-	Multi-Seal (Super TFE) 87A/88A Series

For Pressure/Temperature Ratings, Refer to Page M-9, Graph No. 6

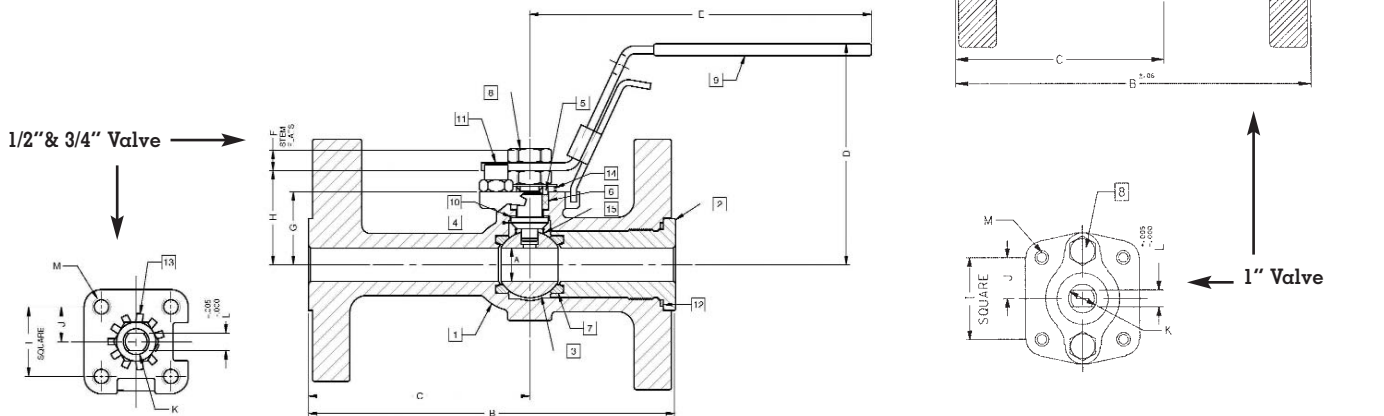

NUMBER	SIZE	A	B	C	D	E	F	G	H	I	J	K	L	M	WT.
87A-903-01	1/2"	0.50	5.50	3.31	3.31	5.11	0.30	1.09	1.38	1.000	0.500	0.375	0.245	10-24	6.0
87A-904-01	3/4"	0.75	6.00	3.56	3.89	5.53	0.36	1.65	1.99	1.392	0.696	0.500	0.287	1/4-20	9.0
87A-905-01	1"	1.00	6.50	3.82	4.62	6.53	0.47	1.62	2.15	1.392	0.696	0.500	0.287	1/4-20	11.0



87A-900 Series

Stainless Steel ANSI Class 300 Flanged Full Port Ball Valve - 1-1/2" through 2-1/2"

STANDARDS COMPLIANCE

Refer to page D-A

STANDARD FEATURES

Refer to page D-A

MATERIALS OF CONSTRUCTION

Description	Material
1. Body	ASTM A351 CF8M
2. Retainer	ASTM A351 CF8M
3. Ball	ASTM A276 Type 316 or A351 CF8M
4. Stem	ASTM A276 Type 316
5. Packing Gland	ASTM A276 Type 316
6. Stem Seals	PTFE
7. Seats	RPTFE
8. Gland Screws	ASTM A193 B8 Class 1
9. Gland Plate	316 SS
10. Stem Nut	18-8 SS
11. Lever	316 SS
12. Stem Bearing	RPTFE
13. Stop	ASTM A276 Type 316
14. Stop Screw	316 SS
15. Lock Plate	302 or 304 SS
16. Body Seal	RPTFE
17. Grounding Spring	SS
18. Body Joint Stud	ASTM A193 Grade B8M
19. Body Joint Nut	ASTM A194 Grade 8
20. Lockwasher	302 or 304 SS

OPTIONS AVAILABLE:

(SUFFIX)	OPTION
-01-	Standard
-14-	Side Vented Ball (Uni-Directional)
-21-	UHMWPE Seats
-24-	Fire Safe (Graphite Packing and Seal)
-35-	PTFE Seats and Seals
-38-	PEEK Seats and Graphite Packing (3" Only)
-49-	Assembled Dry
-57-	Oxygen Cleaned
-60-	Grounded Ball and Stem
-65-	MPTFE Seats and Graphite Packing
-67-	Cleaned For Industrial Gases
-69-	Drilled and Tapped Purge Ports with Plugs
-70-	4" Extended Bonnet
-73-	316 SS Spiral Wound Gaskets w/PTFE Filler
-74-	316 SS Spiral Wound Gaskets w/Graphite Filler
-76-	Live Loaded 87A/88A Series (Lever)
-80-	Multi-Seal (Super TFE) 87A/88A Series
-MG-	Gear Operator with Standard Handwheel
-MH-	Gear Operator with Standard Handwheel & Locking Device
-MJ-	Gear Operator with Oversize Handwheel
-MK-	Gear Operator with Oversize Handwheel & Locking Device

**For Pressure/Temperature Ratings,
Refer to Page M-9, Graph No. 6**

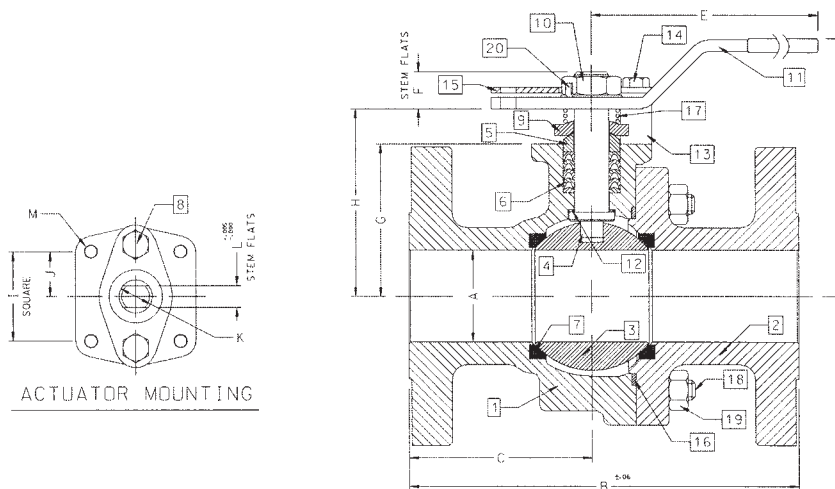

NUMBER	SIZE	A	B	C	D	E	F	G	H	I	J	K	L	M	WT.
87A-907-01	1-1/2"	1.50	7.50	3.50	4.62	6.65	0.72	2.41	3.09	1.949	0.974	0.625	0.412	5/16-18	21.0
87A-908-01	2"	2.00	8.50	4.00	5.61	8.41	0.80	3.31	4.08	1.949	0.974	0.750	0.477	5/16-18	37.0
87A-909-01	2-1/2"	2.50	9.50	4.44	6.24	8.41	0.80	3.94	4.71	1.949	0.974	0.750	0.477	5/16-18	57.0



87A-900 Series

Stainless Steel ANSI Class 300 Flanged Full Port Ball Valve - 3" through 6"

STANDARDS COMPLIANCE

Refer to page D-A

STANDARD FEATURES

Refer to page D-A

MATERIALS OF CONSTRUCTION

Description	Material
1. Body	ASTM A351 CF8M
2. Retainer	ASTM A351 CF8M
3. Ball	ASTM A276 Type 316 or A351 CF8M
4. Stem	ASTM A276 Type 316
5. Packing Gland	ASTM A276 Type 316
6. Stem Seals	PTFE
7. Seats	RPTFE
8. Gland Screws	ASTM A193 B8 Class 1
9. Gland Plate	316 SS
10. Adapter Screw	18-8 SS
11. Handle Adapter	316 SS
12. Stem Bearing	RPTFE
13. Stop	ASTM A276 Type 316
14. Stop Screw	316 SS
15. Lock Plate	302 or 304 SS
16. Body Seal	RPTFE
17. Grounding Spring	SS
18. Body Joint Stud	ASTM A193 Grade B8M
19. Body Joint Nut	ASTM A194 Grade 8
20. Pipe Handle	Galvanized Steel (not shown)

OPTIONS AVAILABLE:

(SUFFIX)	OPTION
-01-	Standard
-14-	Side Vented Ball (Uni-Directional)
-21-	UHMWPE Seats
-24-	Fire Safe (Graphite Packing and Seal)
-35-	PTFE Seats and Seals
-38-	PEEK Seats and Graphite Packing (3" Only)
-49-	Assembled Dry
-57-	Oxygen Cleaned (SS Valves Only)
-60-	Grounded Ball and Stem
-65-	MPTFE Seats and Graphite Packing
-67-	Cleaned For Industrial Gases
-69-	Drilled and Tapped Purge Port with Plugs
-70-	Extended Bonnet
-73-	316 SS Spiral Wound Gaskets w/PTFE Filler
-74-	316 SS Spiral Wound Gaskets w/Graphite Filler
-76-	Live Loaded 87A/88A Series (Lever)
-80-	Multi-Seal (Super TFE) 87A/88A Series
-MG-	Gear Operator with Standard Handwheel
-MH-	Gear Operator with Standard Handwheel & Locking Device
-MJ-	Gear Operator with Oversize Handwheel
-MK-	Gear Operator with Oversize Handwheel & Locking Device

For Pressure/Temperature Ratings, Refer to Page M-9, Graph No. 6

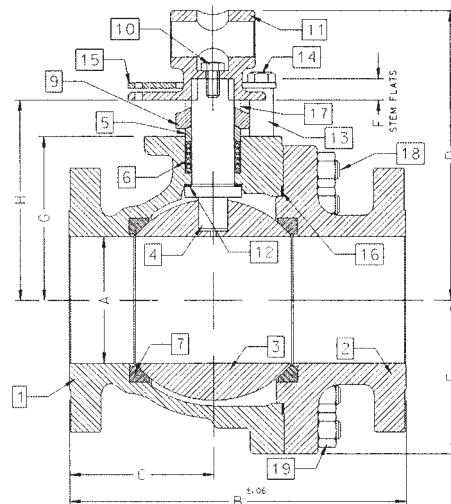
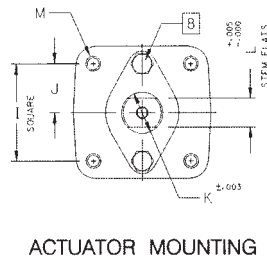

NUMBER	SIZE	A	B	C	D	E	F	G	H	I	J	K	L	M	WT.
87A-900-01	3"	3.00	11.12	5.24	8.80	4.06	0.50	4.75	5.95	2.840	1.420	1.250	0.725	3/8-16	78.0
87A-90A-01	4"	4.00	12.00	5.44	9.99	5.25	0.50	5.94	7.13	2.840	1.420	1.250	0.725	3/8-16	133.0
87A-90C-01	6"	6.00	15.88	6.82	13.73	7.30	1.00	7.75	9.48	4.596	2.298	2.000	1.375	3/4-10	329.0



87A-900 Series

Stainless Steel ANSI Class 300 Flanged Full Port Ball Valve - 8" through 12"

STANDARDS COMPLIANCE

Refer to page D-A

STANDARD FEATURES

Refer to page D-A

MATERIALS OF CONSTRUCTION

Description	Material
1. Body	ASTM A351 CF8M
2. Retainer	ASTM A351 CF8M
3. Ball	ASTM A276 Type 316 or A351 CF8M
4. Stem	ASTM A276 Type 316
5. Packing Gland	ASTM A276 Type 316
6. Stem Seals	PTFE
7. Seats	RPTFE
8. Gland Screws	ASTM A193 B8 Class 1
9. Gland Plate	316 SS
10. Stem Bearing	RPTFE
11. Body Seal	RPTFE
12. Body Joint Stud	ASTM A193 Grade B8M
13. Body Joint Nut	ASTM A194 Grade 8

OPTIONS AVAILABLE:

(SUFFIX)	OPTION
-01-	Standard
-14-	Side Vented Ball (Uni-Directional)
-21-	UHMWPE Seats
-24-	Fire Safe (Graphite Packing and Seal)
-35-	PTFE Seats and Seals
-49-	Assembled Dry
-57-	Oxygen Cleaned
-60-	Grounded Ball and Stem
-65-	MPTFE Seats and Graphite Packing
-69-	Drilled and Tapped Purge Ports with Plugs
-70-	Extended Bonnet (8" Only)
-76-	Live Loaded 87A/88A Series (Lever)
-80-	Multi-Seal (Super TFE) 87A/88A Series
-MG-	Gear Operator with Standard Handwheel
-MH-	Gear Operator with Standard Handwheel & Locking Device
-MJ-	Gear Operator with Oversize Handwheel
-MK-	Gear Operator with Oversize Handwheel & Locking Device

For Pressure/Temperature Ratings, Refer to Page M-9, Graph No. 6

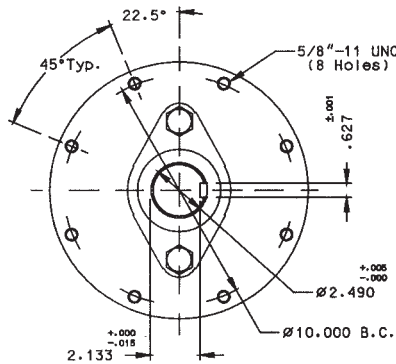

ACTUATOR MOUNTING: 10" & 12"

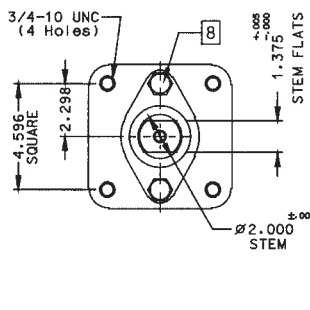

ACTUATOR MOUNTING: 8"

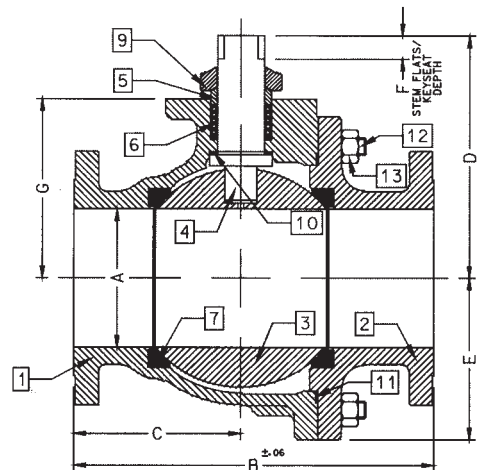

NUMBER	SIZE	A	B	C	D	E	F	G
87A-90E-01	8"	8.00	19.75	9.38	12.83	9.56	1.00	10.22
87A-90G-01	10"	10.00	22.38	10.95	18.57	11.33	2.31	12.80
87A-90H-01	12"	12.00	25.50	12.84	20.31	13.40	2.31	14.92



87B-100 Series

Stainless Steel ANSI Class 150 Flanged Std. Port Ball Valve - 3"

STANDARDS COMPLIANCE

Refer to page D-A

STANDARD FEATURES

Refer to page D-A

MATERIALS OF CONSTRUCTION

Description	Material
1. Body	ASTM A351 CF8M
2. Retainer	ASTM A276 Type 316
3. Ball	ASTM A276 Type 316 or A351 CF8M
4. Stem	ASTM A276 Type 316
5. Packing Gland	ASTM A276 Type 316
6. Stem Seals	PTFE
7. Seats	RPTFE
8. Gland Screws	ASTM A193 B8 Class 1
9. Gland Plate	316 SS
10. Stem Nut	18-8 SS
11. Lever	316 SS with Vinyl Grip
12. Stem Bearing	RPTFE
13. Stop	ASTM A276 Type 316
14. Stop Screw	316 SS
15. Lock Plate	302 or 304 SS
16. Body Seal	RPTFE
17. Grounding Spring	SS
18. Lockwasher	302 or 304 SS

OPTIONS AVAILABLE:

(SUFFIX)	OPTION
-14-	Side Vented Ball (Uni-Directional)
-21-	UHMWPE Seats
-24-	Fire Safe (Graphite Packing and Seal)
-35-	PTFE Seats and Seals
-38-	PEEK Seats and Graphite Packing (3" Only)
-49-	Assembled Dry
-57-	Oxygen Cleaned
-60-	Grounded Ball and Stem
-65-	MPTFE Seats and Graphite Packing
-69-	Drilled and Tapped Purge Ports with Plugs
-70-	4" Extended Bonnet
-76-	Live Loaded 87A/88A Series (Lever)
-80-	Multi-Seal (Super TFE) 87A/88A Series
-MG-	Gear Operator with Standard Handwheel
-MH-	Gear Operator with Standard Handwheel & Locking Device
-MJ-	Gear Operator with Oversize Handwheel
-MK-	Gear Operator with Oversize Handwheel & Locking Device

For Pressure/Temperature Ratings, Refer to Page M-7, Graph No. 2

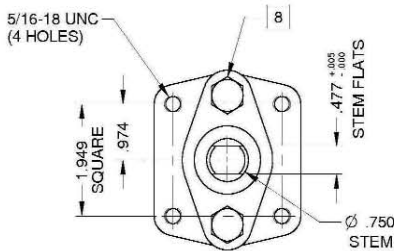

ACTUATOR MOUNTING

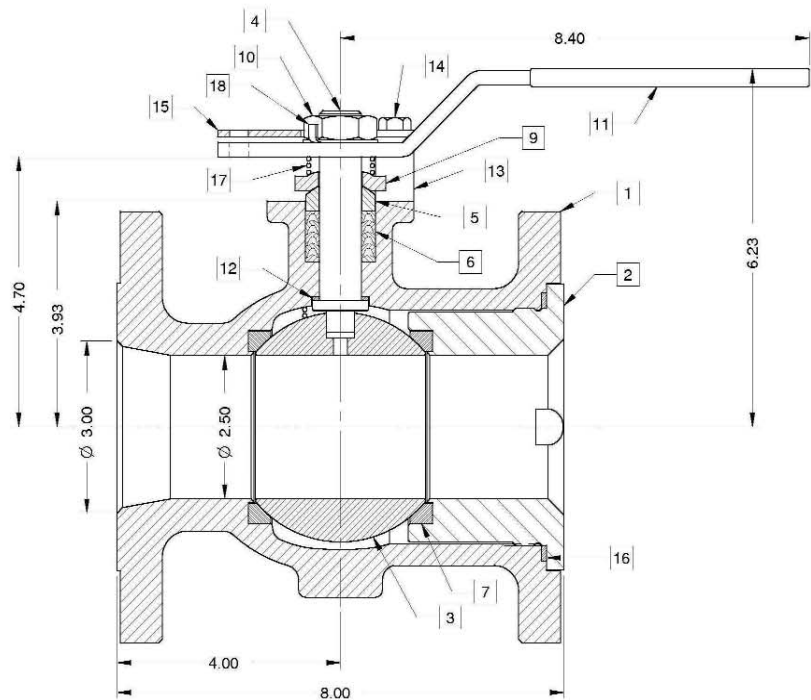



87B-100 Series

Stainless Steel ANSI Class 150 Flanged Std. Port Ball Valve -
4" - 10" Short Pattern

STANDARDS COMPLIANCE

Refer to page D-A

STANDARD FEATURES

Refer to page D-A

MATERIALS OF CONSTRUCTION

Description	Material
1. Body	ASTM A351 CF8M
2. Retainer	ASTM A276 Type 316
3. Ball	ASTM A276 Type 316 or A351 CF8M
4. Stem	ASTM A276 Type 316
5. Packing Gland	ASTM A276 Type 316
6. Stem Seals	PTFE
7. Seats	RPTFE
8. Gland Screws	ASTM A193 B8 Class 1
9. Gland Plate	316 SS
10. Adapter Screw	18-8 SS
11. Handle Adapter	316 SS
12. Stem Bearing	RPTFE
13. Stop	ASTM A276 Type 316
14. Stop Screw	316 SS
15. Lock Plate	302 or 304 SS
16. Body Seal	RPTFE
17. Lockwasher	302 or 304 SS
18. Grounding Spring	SS
19. Adapter Screw	18-8 SS

OPTIONS AVAILABLE:

(SUFFIX)	OPTION
-14-	Side Vented Ball (Uni-Directional)
-21-	UHMWPE Seats
-24-	Fire Safe (Graphite Packing and Seal)
-35-	PTFE Seats and Seals
-38-	PEEK Seats and Graphite Packing (3" Only)
-49-	Assembled Dry
-57-	Oxygen Cleaned
-60-	Grounded Ball and Stem
-65-	MPTFE Seats and Graphite Packing
-69-	Drilled and Tapped Purge Ports with Plugs
-70-	4" Extended Bonnet
-76-	Live Loaded 87A/88A Series (Lever)
-77-	Live Loaded 87A/88A Series (Gear & Actuated)
-80-	Multi-Seal (Super TFE) 87A/88A Series
-MG-	Gear Operator with Standard Handwheel
-MH-	Gear Operator with Standard Handwheel & Locking Device
-MJ-	Gear Operator with Oversize Handwheel
-MK-	Gear Operator with Oversize Handwheel & Locking Device

**For Pressure/Temperature Ratings,
Refer to Page M-7, Graph No. 2**

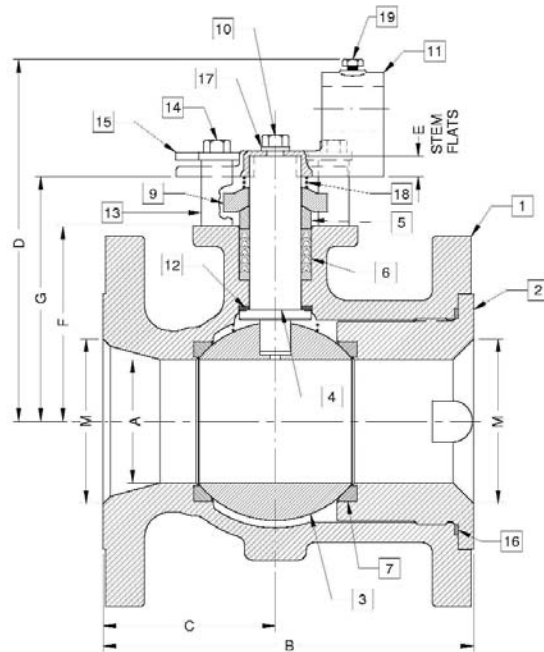
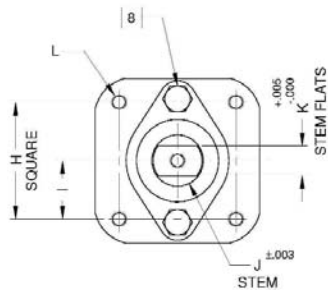

NUMBER	SIZE	A	B	C	D	E	F	G	H	I	J	K	L	M	WT.
87B-10A-01	4"	3.00	9.00	4.18	8.80	0.50	4.75	5.95	2.840	1.420	1.250	0.725	3/8-16	4.00	72
87B-10C-01	6"	4.00	10.50	5.25	9.99	0.50	5.94	7.13	2.840	1.420	1.250	0.725	3/8-16	6.00	110
87B-10E-01	8"	6.00	11.50	5.75	13.61	1.00	7.63	9.36	4.596	2.298	2.000	1.375	3/4-10	8.00	210
87B-10G-01	10"	8.00	13.00	6.50	N/A	1.00	9.50	11.23	4.596	2.298	2.000	1.375	3/4-10	10.0	350



88A-100 Series

Carbon Steel ANSI Class 150 Flanged Std. Port Ball Valve - 1-1/2" through 2"

STANDARDS COMPLIANCE

Refer to page D-A

STANDARD FEATURES

Refer to page D-A

MATERIALS OF CONSTRUCTION

Description	Material
1. Body	ASTM A216 WCB
2. Retainer	ASTM A108 Type 1215
3. Ball	ASTM A108 Type 1215 Chrome Plated
4. Stem	ASTM A108 Type 1215
5. Packing Gland	ASTM A108 Type 1215
6. Stem Seals	PTFE
7. Seats	RPTFE
8. Gland Screws	ASTM A193 B7
9. Gland Plate	302 or 304 SS
10. Stem Nut	316 SS
11. Lever	ASTM A366 Steel with Vinyl Grip
12. Stem Bearing	RPTFE
13. Stop	ASTM A108 Type 1215
14. Stop Screw	SAE J429 Grade 2
15. Lock Plate	ASTM A366 Steel
16. Body Seal	RPTFE
17. Lockwasher	302 or 304 SS
18. Grounding Spring	SS

VARIATIONS AVAILABLE:

88A-140 Series (316 SS Ball & Stem)

88A-130 Series (Ni-Cu Ball & Stem)

OPTIONS AVAILABLE:

(SUFFIX)	OPTION
-01-	Standard
-10-	SS Lever and Nut
-14-	Side Vented Ball (Uni-Directional)
-15-	Wheel Handle, Steel
-21-	UHMWPE Seats
-24-	Fire Safe (Graphite Packing and Seal)
-35-	PTFE Seats and Seals
-38-	PEEK Seats and Graphite Packing
-49-	Assembled Dry
-60-	Grounded Ball and Stem
-65-	MPTFE Seats and Graphite Packing
-67-	Cleaned For Industrial Gases
-69-	Drilled and Tapped Purge Port with Plug
-70-	4" Extended Bonnet
-73-	316 SS Spiral Wound Gaskets w/PTFE Filler
-74-	316 SS Spiral Wound Gaskets w/Graphite Filler
-76-	Live Loaded 87A/88A Series (Lever)
-80-	Multi-Seal (Super TFE) 87A/88A Series

**For Pressure/Temperature Ratings,
Refer to Page M-7, Graph No. 1**

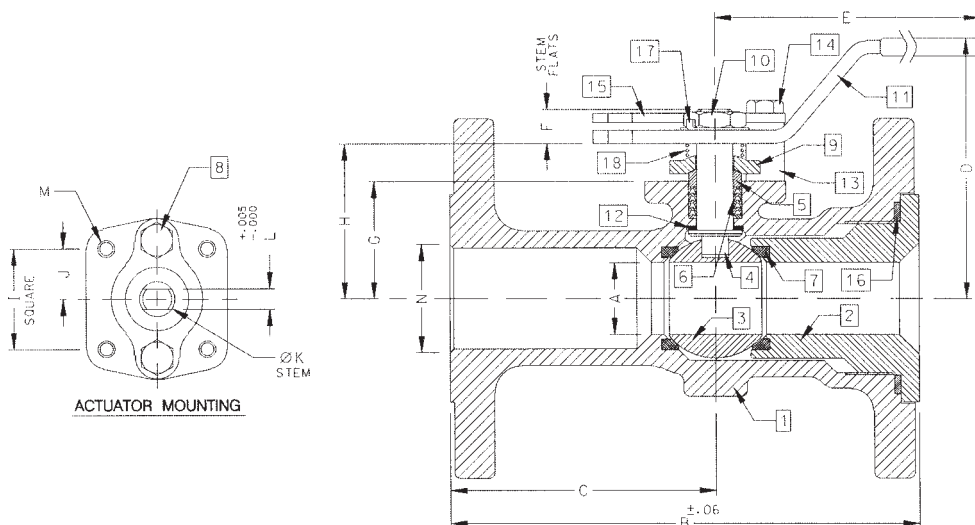

NUMBER	SIZE	A	B	C	D	E	F	G	H	I	J	K	L	M	N	WT.
88A-107-01A	1-1/2"	1.25	6.50	3.50	4.85	6.53	0.47	1.85	2.38	1.392	0.696	0.500	0.287	1/4-20	1.50	9.0
88A-108-01	2"	1.50	7.00	3.69	4.62	6.65	0.72	2.41	3.09	1.949	0.974	0.625	0.412	5/16-18	2.00	18.0



88A-100 Series

Carbon Steel ANSI Class 150 Flanged Std. Port Ball Valve - 2-1/2" through 3"

STANDARDS COMPLIANCE

Refer to page D-A

STANDARD FEATURES

Refer to page D-A

MATERIALS OF CONSTRUCTION

Description	Material
1. Body	ASTM A216 WCB
2. Retainer	ASTM A216 WCB
3. Ball	ASTM A216 WCB or A216 WCB Chrome Plated
4. Stem	ASTM A108 Type 1215
5. Packing Gland	ASTM A108 Type 1215
6. Stem Seals	PTFE
7. Seats	RPTFE
8. Gland Screws	ASTM A193 B7
9. Gland Plate	302 or 304 SS
10. Stem Nut	ASTM A194 Grade 8
11. Lever	ASTM A366 Steel with Vinyl Grip
12. Stem Bearing	RPTFE
13. Stop	ASTM A108 Type 1215
14. Stop Screw	SAE J429 Grade 2
15. Lock Plate	ASTM A366 Steel
16. Body Seal	RPTFE
17. Grounding Spring	SS
18. Body Joint Stud	ASTM A193 Grade B7
19. Body Joint Nut	ASTM A194 Grade 2H
20. Lockwasher	302 or 304 SS

VARIATIONS AVAILABLE:

88A-140 Series (316 SS Ball & Stem)

88A-130 Series (Ni-Cu Ball & Stem)

OPTIONS AVAILABLE:

(SUFFIX)	OPTION
-01-	Standard
-10-	SS Lever and Nut
-14-	Side Vented Ball (Uni-Directional)
-21-	UHMWPE Seats
-24-	Fire Safe (Graphite Packing and Seal)
-35-	PTFE Seats and Seals
-38-	PEEK Seats and Graphite Packing
-49-	Assembled Dry
-59-	SS External Trim
-60-	Grounded Ball and Stem
-65-	MPTFE Seats and Graphite Packing
-67-	Cleaned For Industrial Gases
-69-	Drilled and Tapped Purge Port with Plugs
-70-	4" Extended Bonnet
-73-	316 SS Spiral Wound Gaskets w/PTFE Filler
-74-	316 SS Spiral Wound Gaskets w/Graphite Filler
-76-	Live Loaded 87A/88A Series (Lever)
-80-	Multi-Seal (Super TFE) 87A/88A Series
-MG-	Gear Operator with Standard Handwheel
-MH-	Gear Operator with Standard Handwheel & Locking Device
-MJ-	Gear Operator with Oversize Handwheel
-MK-	Gear Operator with Oversize Handwheel & Locking Device

**For Pressure/Temperature Ratings,
Refer to Page M-7, Graph No. 1**

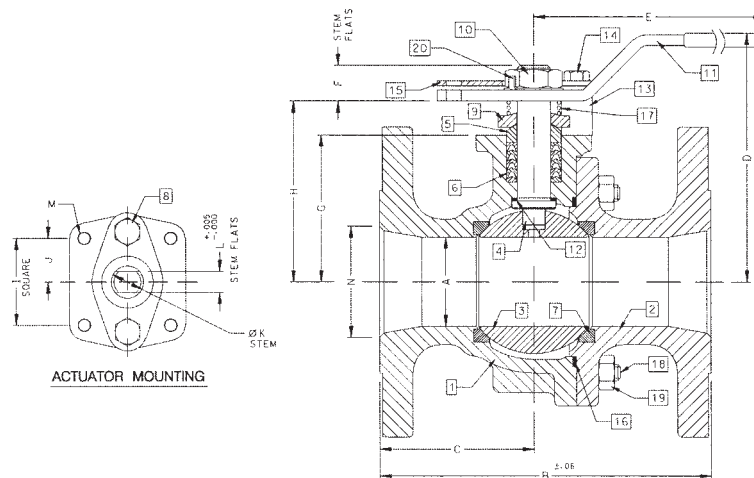

NUMBER	SIZE	A	B	C	D	E	F	G	H	I	J	K	L	M	N	WT.
88A-109-01	2-1/2"	2.00	7.50	3.50	5.61	8.41	0.80	3.31	4.08	1.949	0.974	0.750	0.477	5/16-18	2.50	27.0
88A-100-01	3"	2.50	8.00	3.51	6.24	8.41	0.80	3.94	4.71	1.949	0.974	0.750	0.477	5/16-18	3.00	34.0



88A-100 Series

Carbon Steel ANSI Class 150 Flanged Std. Port Ball Valve - 4" through 8"

STANDARDS COMPLIANCE

Refer to page D-A

STANDARD FEATURES

Refer to page D-A

MATERIALS OF CONSTRUCTION

Description	Material
1. Body	ASTM A216 WCB
2. Retainer	ASTM A216 WCB
3. Ball	ASTM A216 WCB or A216 WCB Chrome Plated
4. Stem	ASTM A108 Type 1215
5. Packing Gland	ASTM A108 Type 1215
6. Stem Seals	PTFE
7. Seats	RPTFE
8. Gland Screws	ASTM A193 B7
9. Gland Plate	316 SS
10. Adaptor Screw	316 SS
11. Handle Adapter	ASTM A366 Steel with Vinyl Grip
12. Stem Bearing	RPTFE
13. Stop	ASTM A108 Type 1215
14. Stop Screw	SAE J429 Grade 2
15. Lock Plate	ASTM A366 Steel
16. Body Seal	RPTFE
17. Grounding Spring	SS
18. Body Joint Stud	ASTM A193 Grade B7
19. Body Joint Nut	ASTM A194 Grade 2H
20. Adapter Screw	18-8 SS
21. Pipe Handle	Galvanized Steel (not shown)

VARIATIONS AVAILABLE:

88A-140 Series (316 SS Ball & Stem)

88A-130 Series (Ni-Cu Ball & Stem)

OPTIONS AVAILABLE:

(SUFFIX)	OPTION
-01-	Standard
-14-	Side Vented Ball (Uni-Directional)
-21-	UHMWPE Seats
-24-	Fire Safe (Graphite Packing and Seal)
-35-	PTFE Seats and Seals
-49-	Assembled Dry
-57-	Oxygen Cleaned (SS Valves Only)
-59-	SS External Trim
-60-	Grounded Ball and Stem
-65-	MPTFE Seats and Graphite Packing
-67-	Cleaned For Industrial Gases
-69-	Drilled and Tapped Purge Ports with Plugs
-70-	Extended Bonnet
-73-	316 SS Spiral Wound Gaskets w/PTFE Filler
-74-	316 SS Spiral Wound Gaskets w/Graphite Filler
-76-	Live Loaded 87A/88A Series (Lever)
-80-	Multi-Seal (Super TFE) 87A/88A Series
-MG-	Gear Operator with Standard Handwheel
-MH-	Gear Operator with Standard Handwheel & Locking Device
-MJ-	Gear Operator with Oversize Handwheel
-MK-	Gear Operator with Oversize Handwheel & Locking Device

**For Pressure/Temperature Ratings,
Refer to Page M-7, Graph No. 1**

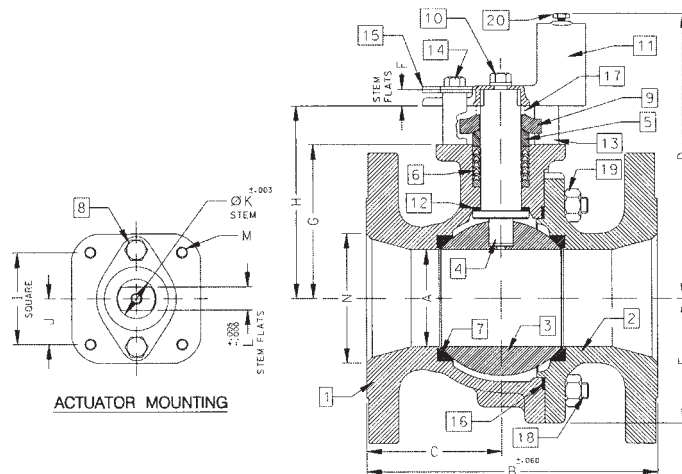

NUMBER	SIZE	A	B	C	D	E	F	G	H	I	J	K	L	M	N	WT.
88A-10A-01	4"	3.00	9.00	4.18	8.80	3.88	0.50	4.75	5.95	2.840	1.420	1.250	0.725	3/8-16	4.00	73.0
88A-10C-01	6"	4.00	10.50	4.69	9.99	5.13	0.50	5.94	7.13	2.840	1.420	1.250	0.725	3/8-16	6.00	117.0
88A-10E-01	8"	6.00	18.00	9.00	13.73	7.00	1.00	7.75	9.48	4.596	2.298	2.000	1.375	3/4-10	8.00	310.0



88A-100 Series

Carbon Steel ANSI Class 150 Flanged Std. Port Ball Valve - 10"

STANDARDS COMPLIANCE

Refer to page D-A

STANDARD FEATURES

Refer to page D-A

MATERIALS OF CONSTRUCTION

Description	Material
1. Body	ASTM A216 WCB
2. Retainer	ASTM A216 WCB
3. Ball	ASTM A108 Type 1215 or A216 WCB Chrome Plated
4. Stem	ASTM A108 Type 1215
5. Packing Gland	ASTM A108 Type 1215
6. Stem Seals	PTFE
7. Seats	RPTFE
8. Gland Screws	ASTM A193 B7
9. Gland Plate	316 SS
10. Stem Bearing	RPTFE
11. Body Seal	RPTFE
12. Body Joint Stud	ASTM A193 Grade B7
13. Body Joint Nut	ASTM A194 Grade 2H

VARIATIONS AVAILABLE:

- 88A-130 Series (Ni-Cu Ball & Stem)
- 88A-140 Series (316 SS Ball & Stem)

OPTIONS AVAILABLE:

(SUFFIX)	OPTION
-01-	Standard
-14-	Side Vented Ball (Uni-Directional)
-21-	UHMWPE Seats
-24-	Fire Safe (Graphite Packing and Seal)
-35-	PTFE Seats and Seals
-49-	Assembled Dry
-57-	Oxygen Cleaned
-60-	Grounded Ball and Stem
-65-	MPTFE Seats and Graphite Packing
-67-	Cleaned For Industrial Gases
-69-	Drilled and Tapped Purge Port with Plugs
-70-	Extended Bonnet
-76-	Live Loaded 87A/88A Series (Lever)
-80-	Multi-Seal (Super TFE) 87A/88A Series
-MG-	Gear Operator with Standard Handwheel
-MH-	Gear Operator with Standard Handwheel & Locking Device
-MJ-	Gear Operator with Oversize Handwheel
-MK-	Gear Operator with Oversize Handwheel & Locking Device

**For Pressure/Temperature Ratings,
Refer to Page M-7, Graph No. 1**

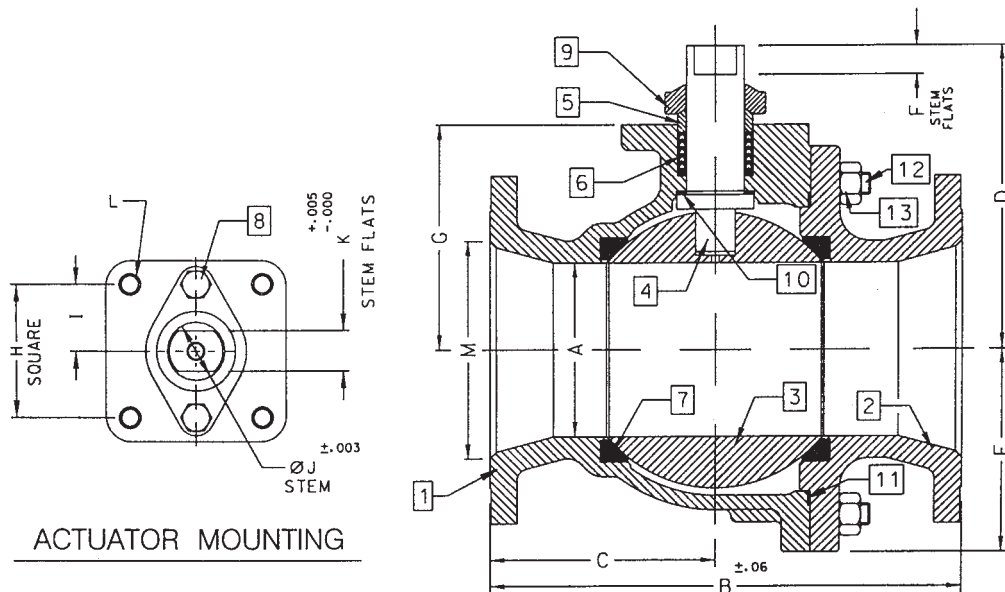

NUMBER	SIZE	A	B	C	D	E	F	G	H	I	J	K	L	M
88A-10G-01	10"	8.00	21.00	10.37	12.83	9.18	1.00	10.22	4.596	2.298	2.000	1.375	3/4-10	10.00



88A-200 Series

Carbon Steel ANSI Class 150 Flanged Full Port Ball Valve - 1/2" through 1"

STANDARDS COMPLIANCE

Refer to page D-A

MATERIALS OF CONSTRUCTION

Description (1/2" & 3/4" Valves)	Material
1. Body	ASTM A216 WCB
2. Retainer	ASTM A108 Type 1215
3. Ball	ASTM A108 Type 1215
4. Stem	ASTM A108 Type 1215
5. Packing Gland	ASTM A108 Type 1215
6. Stem Seals	PTFE
7. Seats	RPTFE
8. Stem Nut	300 Series Stainless Steel
9. Lever	300 Series Stainless Steel w/Vinyl Grip
10. Stem Bearing	RPTFE
11. Stop	300 Series Stainless Steel
12. Body Seal	RPTFE
13. Lock Washer	300 Series Stainless Steel
14. Grounding Spring	ASTM A313 Stainless Steel
15. Grounding Spring	ASTM A313 Stainless Steel

Description (1" Valves)	Material
1. Body	ASTM A216 WCB
2. Retainer	ASTM A108 Type 1215
3. Ball	ASTM A108 Type 1215 Chrome Plated
4. Stem	ASTM A108 Type 1215
5. Packing Gland	ASTM A108 Type 1215
6. Stem Seals	PTFE
7. Seats	RPTFE
8. Gland Screws	ASTM A193 B7
9. Gland Plate	302 or 304 SS
10. Stem Nut	316 SS
11. Lever	ASTM A366 Steel with Vinyl Grip
12. Stem Bearing	RPTFE
13. Stop	ASTM A108 Type 1215
14. Stop Screw	SAE J429 Grade 2
15. Lock Plate	ASTM A366 Steel
16. Body Seal	RPTFE
17. Lockwasher	302 or 304 SS
18. Grounding Spring	SS

STANDARD FEATURES

Refer to page D-A

VARIATIONS AVAILABLE:

88A-240 Series (316 SS Ball & Stem)

88A-230 Series (Ni-Cu Ball & Stem)

OPTIONS AVAILABLE:

(SUFFIX)	OPTION
-01-	Standard
-10-	SS Lever and Nut
-14-	Side Vented Ball (Uni-Directional)
-15-	Wheel Handle, Steel
-21-	UHMWPE Seats
-24-	Fire Safe (Graphite Packing and Seal)
-35-	PTFE Seats and Seals
-38-	PEEK Seats and Graphite Packing
-49-	Assembled Dry
-60-	Grounded Ball and Stem
-65-	MPTFE Seats and Graphite Packing
-67-	Cleaned For Industrial Gases
-69-	Drilled and Tapped Purge Port with Plug
-70-	4" Extended Bonnet
-73-	316 SS Spiral Wound Gaskets w/PTFE Filler
-74-	316 SS Spiral Wound Gaskets w/Graphite Filler
-76-	Live Loaded 87A/88A Series (Lever)
-80-	Multi-Seal (Super TFE) 87A/88A Series

For Pressure/Temperature Ratings, Refer to Page M-7, Graph No. 1

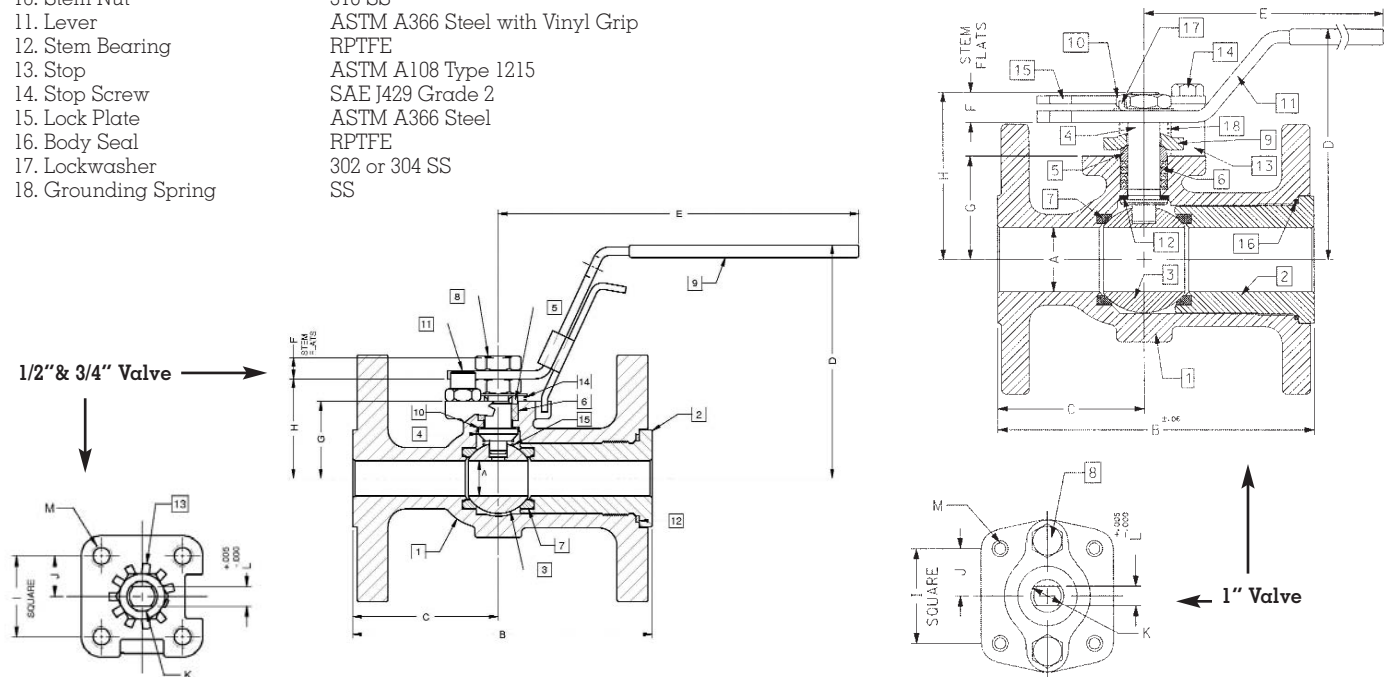

NUMBER	SIZE	A	B	C	D	E	F	G	H	I	J	K	L	M	WT.
88A-203-01	1/2"	0.50	4.25	2.06	3.31	5.11	.30	1.09	1.41	1.002	.501	.375	.245	10-24	5.0
88A-204-01	3/4"	0.75	4.62	2.18	3.89	5.53	.36	1.65	1.99	1.392	.696	.500	.287	1/4-20	6.0
88A-205-01	1"	1.00	5.00	2.32	4.62	6.53	0.47	1.62	2.15	1.392	0.696	0.500	0.287	1/4-20	7.0



88A-200 Series

Carbon Steel ANSI Class 150 Flanged Full Port Ball Valve - 1-1/2" through 2-1/2"

STANDARDS COMPLIANCE

Refer to page D-A

STANDARD FEATURES

Refer to page D-A

MATERIALS OF CONSTRUCTION

Description	Material
1. Body	ASTM A216 WCB
2. Retainer	ASTM A216 WCB
3. Ball	ASTM A216 WCB or A216 WCB Chrome Plated
4. Stem	ASTM A108 Type 1215
5. Packing Gland	ASTM A108 Type 1215
6. Stem Seals	PTFE
7. Seats	RPTFE
8. Gland Screws	ASTM A193 B7
9. Gland Plate	302 & 304 SS
10. Stem Nut	ASTM A194 Grade 8l
11. Lever	ASTM A366 Steel with Vinyl Grip
12. Stem Bearing	RPTFE
13. Stop	ASTM A108 Type 1215
14. Stop Screw	SAE J429 Grade 2
15. Lock Plate	ASTM A366 Steel
16. Body Seal	RPTFE
17. Grounding Spring	SS
18. Body Joint Stud	ASTM A193 Grade B7
19. Body Joint Nut	ASTM A194 Grade 2H
20. Lockwasher	302 or 304 SS

VARIATIONS AVAILABLE:

88A-240 Series (316 SS Ball & Stem)

88A-230 Series (Ni-Cu Ball & Stem)

OPTIONS AVAILABLE:

(SUFFIX)	OPTION
-01-	Standard
-10-	SS Lever and Nut
-14-	Side Vented Ball (Uni-Directional)
-15-	Wheel Handle, Steel
-21-	UHMWPE Seats
-24-	Fire Safe (Graphite Packing and Seal)
-35-	PTFE Seats and Seals
-38-	PEEK Seats and Graphite Packing
-49-	Assembled Dry
-59-	SS External Trim
-60-	Grounded Ball and Stem
-65-	MPTEF Seats and Graphite Packing
-67-	Cleaned For Industrial Gases
-69-	Drilled and Tapped Purge Ports with Plugs
-70-	4" Extended Bonnet
-73-	316 SS Spiral Wound Gaskets w/PTFE Filler
-74-	316 SS Spiral Wound Gaskets w/Graphite Filler
-76-	Live Loaded 87A/88A Series (Lever)
-80-	Multi-Seal (Super TFE) 87A/88A Series
-MG-	Gear Operator with Standard Handwheel
-MH-	Gear Operator with Standard Handwheel & Locking Device
-MJ-	Gear Operator with Oversize Handwheel
-MK-	Gear Operator with Oversize Handwheel & Locking Device

**For Pressure/Temperature Ratings,
Refer to Page M-7, Graph No. 1**

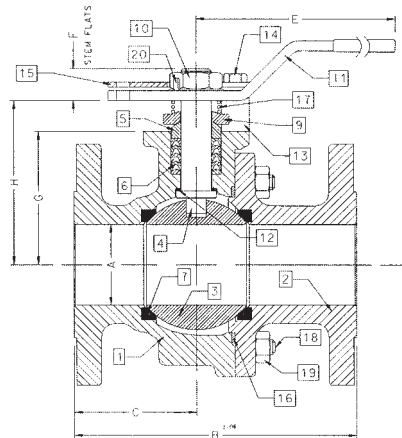
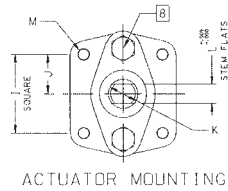

NUMBER	SIZE	A	B	C	D	E	F	G	H	I	J	K	L	M	WT.
88A-207-01	1-1/2"	1.50	6.50	3.00	4.62	6.65	0.72	2.41	3.09	1.949	0.974	0.625	0.412	5/16-18	14.0
88A-208-01	2"	2.00	7.00	3.04	5.61	8.41	0.80	3.31	4.08	1.949	0.974	0.750	0.477	5/16-18	25.0
88A-209-01	2-1/2"	2.50	7.50	3.34	6.24	8.41	0.80	3.94	4.71	1.949	0.974	0.750	0.477	5/16-18	30.0



88A-200 Series

Carbon Steel ANSI Class 150 Flanged Full Port Ball Valve - 3" through 6"

STANDARDS COMPLIANCE

Refer to page D-A

STANDARD FEATURES

Refer to page D-A

MATERIALS OF CONSTRUCTION

Description	Material
1. Body	ASTM A216 WCB
2. Retainer	ASTM A216 WCB
3. Ball	ASTM A108 Type 1215 or A216 WCB Chrome Plated
4. Stem	ASTM A108 Type 1215
5. Packing Gland	ASTM A108 Type 1215
6. Stem Seals	PTFE
7. Seats	RPTFE
8. Gland Screws	ASTM A193 B7
9. Gland Plate	316 SS
10. Adapter Screw	316 SS
11. Handle Adapter	ASTM A366 Steel with Vinyl Grip
12. Stem Bearing	RPTFE
13. Stop	ASTM A108 Type 1215
14. Stop Screw	SAE J429 Grade 2
15. Lock Plate	ASTM A366 Steel
16. Body Seal	RPTFE
17. Grounding Spring	SS
18. Body Joint Stud	ASTM A193 Grade B7
19. Body Joint Nut	ASTM A194 Grade 2H
20. Pipe Handle	Galvanized Steel (not shown)

VARIATIONS AVAILABLE:

- 88A-240 Series (316 SS Ball & Stem)
- 88A-230 Series (Ni-Cu Ball & Stem)

OPTIONS AVAILABLE:

(SUFFIX)	OPTION
-01-	Standard
-14-	Side Vented Ball (Uni-Directional)
-21-	UHMWPE Seats
-24-	Fire Safe (Graphite Packing and Seal)
-35-	PTFE Seats and Seals
-38-	PEEK Seats and Graphite Packing
-49-	Assembled Dry
-59-	SS External Trim
-60-	Grounded Ball and Stem
-65-	MPTFE Seats and Graphite Packing
-67-	Cleaned For Industrial Gases
-69-	Drilled and Tapped Purge Port with Plug
-70-	4" Extended Bonnet
-73-	316 SS Spiral Wound Gaskets w/PTFE Filler
-74-	316 SS Spiral Wound Gaskets w/Graphite Filler
-76-	Live Loaded 87A/88A Series (Lever)
-80-	Multi-Seal (Super TFE) 87A/88A Series
-MG-	Gear Operator with Standard Handwheel
-MH-	Gear Operator with Standard Handwheel & Locking Device
-MJ-	Gear Operator with Oversize Handwheel
-MK-	Gear Operator with Oversize Handwheel & Locking Device

**For Pressure/Temperature Ratings,
Refer to Page M-7, Graph No. 1**

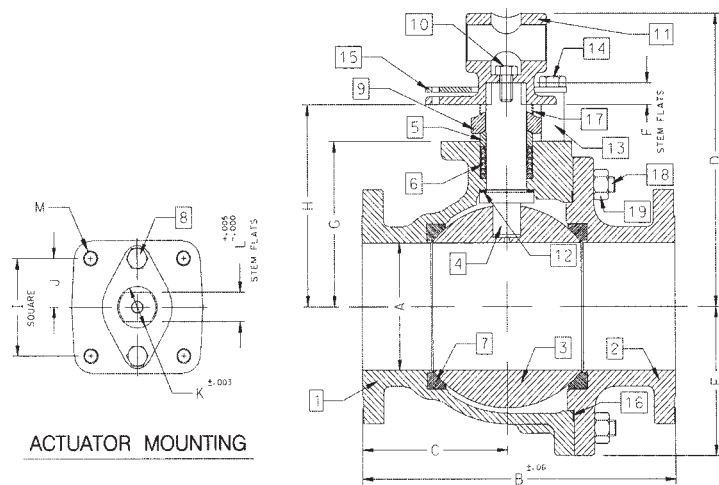

NUMBER	SIZE	A	B	C	D	E	F	G	H	I	J	K	L	M	WT.
88A-200-01	3"	3.00	8.00	3.68	8.80	3.88	0.50	4.75	5.95	2.840	1.420	1.250	0.725	3/8-16	60.0
88A-20A-01	4"	4.00	9.00	3.94	9.99	5.13	0.50	5.94	7.13	2.840	1.420	1.250	0.725	3/8-16	91.0
88A-20C-01	6"	6.00	15.50	7.19	13.73	7.00	1.00	7.75	9.48	4.596	2.298	2.000	1.375	3/4-10	248.0



88A-200 Series

Carbon Steel ANSI Class 150 Flanged Full Port Ball Valve - 8" through 12"

STANDARDS COMPLIANCE

Refer to page D-A

STANDARD FEATURES

Refer to page D-A

MATERIALS OF CONSTRUCTION

Description	Material
1. Body	ASTM C216 WCB
2. Retainer	ASTM C216 WCB
3. Ball	ASTM A108 Type 1215 or A216 WCB Chrome Plated
4. Stem	ASTM A108 Type 1215
5. Packing Gland	ASTM A108 Type 1215
6. Stem Seals	PTFE
7. Seats	RPTFE
8. Gland Screws	ASTM A193 B7
9. Gland Plate	316 SS
10. Stem Bearing	RPTFE
11. Body Seal	RPTFE
12. Body Joint Stud	ASTM A193 Grade B7
13. Body Joint Nut	ASTM A194 Grade 2H

VARIATIONS AVAILABLE:

88A-230 Series (Ni-Cu Ball & Stem)

88A-240 Series (316 SS Ball & Stem)

OPTIONS AVAILABLE:

(SUFFIX)	OPTION
-01-	Standard
-14-	Side Vented Ball (Uni-Directional)
-21-	UHMWPE Seats
-24-	Fire Safe (Graphite Packing and Seal)
-35-	PTFE Seats and Seals
-49-	Assembled Dry
-65-	MPTFE Seats and Graphite Packing
-67-	Cleaned for Industrial Gas - CS Valves
-69-	Drilled and Tapped Purge Ports with Plugs
-70-	Extended Bonnet (8" Only)
-76-	Live Loaded 87A/88A Series (Lever)
-80-	Multi-Seal (Super TFE) 87A/88A Series
-MG-	Gear Operator with Standard Handwheel
-MH-	Gear Operator with Standard Handwheel & Locking Device
-MJ-	Gear Operator with Oversize Handwheel
-MK-	Gear Operator with Oversize Handwheel & Locking Device

**For Pressure/Temperature Ratings,
Refer to Page M-7, Graph No. 1**

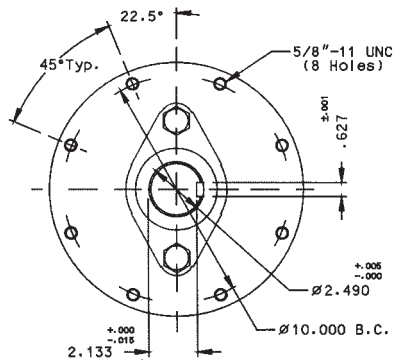

ACTUATOR MOUNTING: 10" & 12"

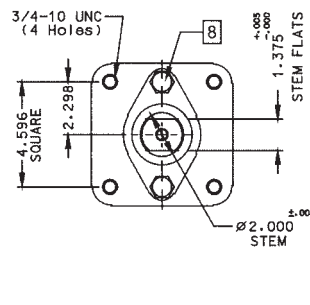

ACTUATOR MOUNTING: 8"

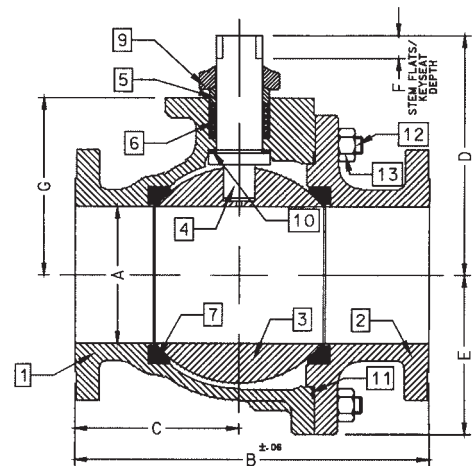

NUMBER	SIZE	A	B	C	D	E	F	G
88A-20E-01	8"	8.00	18.00	8.88	12.83	9.18	1.00	10.22
88A-20G-01	10"	10.00	21.00	10.26	18.57	11.33	2.31	12.80
88A-20H-01	12"	12.00	24.00	12.09	20.31	13.40	2.31	14.92



88A-700 Series

Carbon Steel ANSI Class 300 Flanged Std. Port Ball Valve - 1-1/2" through 2"

STANDARDS COMPLIANCE

Refer to page D-A

STANDARD FEATURES

Refer to page D-A

MATERIALS OF CONSTRUCTION

Description	Material
1. Body	ASTM A216 WCB
2. Retainer	ASTM A108 Type 1215
3. Ball	ASTM A108 Type 1215 Chrome Plated
4. Stem	ASTM A108 Type 1215
5. Packing Gland	ASTM A108 Type 1215
6. Stem Seals	PTFE
7. Seats	RPTFE
8. Gland Screws	ASTM A193 B7
9. Gland Plate	302 & 304 SS
10. Stem Nut	316 SS
11. Lever	ASTM A366 Steel with Vinyl Grip
12. Stem Bearing	RPTFE
13. Stop	ASTM A108 Type 1215
14. Stop Screw	SAE J429 Grade 2
15. Lock Plate	ASTM A366 Steel
16. Body Seal	RPTFE
17. Lockwasher	302 or 304 SS
18. Grounding Spring	SS

VARIATIONS AVAILABLE:

- 88A-740 Series (316 SS Ball & Stem)
- 88A-730 Series (Ni-Cu Ball & Stem)

OPTIONS AVAILABLE:

(SUFFIX)	OPTION
-01-	Standard
-10-	SS Lever and Nut
-14-	Side Vented Ball (Uni-Directional)
-15-	Wheel Handle, Steel
-21-	UHMWPE Seats
-24-	Fire Safe (Graphite Packing and Seal)
-35-	PTFE Seats and Seals
-38-	PEEK Seats and Graphite Packing
-49-	Assembled Dry
-60-	Grounded Ball and Stem
-65-	MPTFE Seats and Graphite Packing
-67-	Cleaned For Industrial Gases
-69-	Drilled and Tapped Purge Ports with Plugs
-70-	4" Extended Bonnet
-73-	316 SS Spiral Wound Gaskets w/PTFE Filler
-74-	316 SS Spiral Wound Gaskets w/Graphite Filler
-76-	Live Loaded 87A/88A Series (Lever)
-80-	Multi-Seal (Super TFE) 87A/88A Series

**For Pressure/Temperature Ratings,
Refer to Page M-9, Graph No. 5**

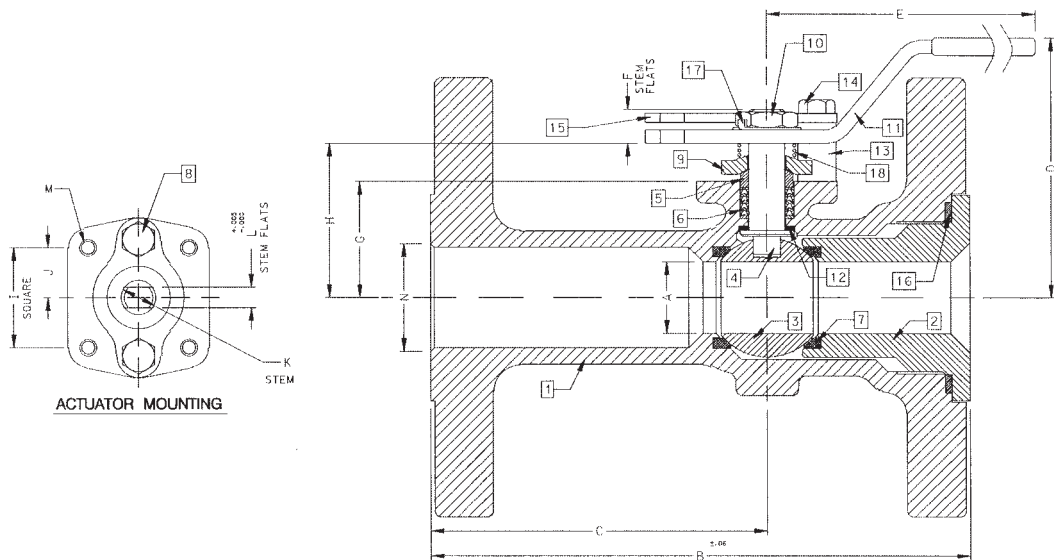

NUMBER	SIZE	A	B	C	D	E	F	G	H	I	J	K	L	M	N	WT.
88A-707-01	1-1/2"	1.25	7.50	4.50	4.85	6.53	0.47	1.85	2.38	1.392	0.696	0.500	0.287	1/4-20	1.50	16.0
88A-708-01	2"	1.50	8.50	5.19	4.62	6.65	0.72	2.41	3.09	1.949	0.974	0.625	0.412	5/16-18	2.00	24.0



88A-700 Series

Carbon Steel ANSI Class 300 Flanged Std. Port Ball Valve - 2-1/2" through 3"

STANDARDS COMPLIANCE

Refer to page D-A

STANDARD FEATURES

Refer to page D-A

MATERIALS OF CONSTRUCTION

Description	Material
1. Body	ASTM A216 WCB
2. Retainer	ASTM A216 WCB
3. Ball	ASTM A108 Type 1215 or A216 WCB Chrome Plated
4. Stem	ASTM A108 Type 1215
5. Packing Gland	ASTM A108 Type 1215
6. Stem Seals	PTFE
7. Seats	RPTFE
8. Gland Screws	ASTM A193 B7
9. Gland Plate	302 or 304 SS
10. Stem Nut	ASTM A194 Grade 8
11. Lever	ASTM A366 Steel with Vinyl Grip
12. Stem Bearing	RPTFE
13. Stop	ASTM A108 Type 1215
14. Stop Screw	SAE J429 Grade 2
15. Lock Plate	ASTM A366 Steel
16. Body Seal	RPTFE
17. Grounding Spring	SS
18. Body Joint Stud	ASTM A193 Grade B7
19. Body Joint Nut	ASTM A194 Grade 2H
20. Lockwasher	302 or 304 SS

VARIATIONS AVAILABLE:

88A-740 Series (316 SS Ball & Stem)

88A-730 Series (Ni-Cu Ball & Stem)

OPTIONS AVAILABLE:

(SUFFIX)	OPTION
-01-	Standard
-10-	SS Lever and Nut
-14-	Side Vented Ball (Uni-Directional)
-15-	Wheel Handle, Steel
-21-	UHMWPE Seats
-24-	Fire Safe (Graphite Packing and Seal)
-35-	PTFE Seats and Seals
-38-	PEEK Seats and Graphite Packing
-49-	Assembled Dry
-59-	SS External Trim
-60-	Grounded Ball and Stem
-65-	MPTFE Seats and Graphite Packing
-67-	Cleaned For Industrial Gases
-69-	Drilled and Tapped Purge Port with Plug
-70-	4" Extended Bonnet
-73-	316 SS Spiral Wound Gaskets w/PTFE Filler
-74-	316 SS Spiral Wound Gaskets w/Graphite Filler
-76-	Live Loaded 87A/88A Series (Lever)
-80-	Multi-Seal (Super TFE) 87A/88A Series
-MG-	Gear Operator with Standard Handwheel
-MH-	Gear Operator with Standard Handwheel & Locking Device
-MJ-	Gear Operator with Oversize Handwheel
-MK-	Gear Operator with Oversize Handwheel & Locking Device

**For Pressure/Temperature Ratings,
Refer to Page M-9, Graph No. 5**

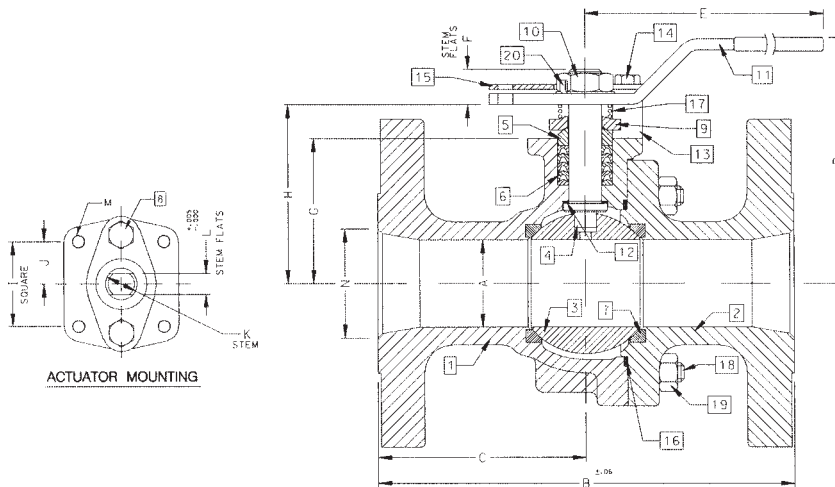

NUMBER	SIZE	A	B	C	D	E	F	G	H	I	J	K	L	M	N	WT.
88A-709-01	2-1/2"	2.00	9.50	4.75	5.61	8.41	0.80	3.31	4.08	1.949	0.974	0.750	0.477	5/16-18	2.50	39.0
88A-700-01	3"	2.50	11.12	5.56	6.24	8.41	0.80	3.94	4.71	1.949	0.974	0.750	0.477	5/16-18	3.00	55.0



88A-700 Series

Carbon Steel ANSI Class 300 Flanged Std. Port Ball Valve - 4" through 8"

STANDARDS COMPLIANCE

Refer to page D-A

STANDARD FEATURES

Refer to page D-A

MATERIALS OF CONSTRUCTION

Description	Material
1. Body	ASTM A216 WCB
2. Retainer	ASTM A216 WCB
3. Ball	ASTM A108 Type 1215 or A216 WCB Chrome Plated
4. Stem	ASTM A108 Type 1215
5. Packing Gland	ASTM A108 Type 1215
6. Stem Seals	PTFE
7. Seats	RPTFE
8. Gland Screws	ASTM A193 B7
9. Gland Plate	316 SS
10. Adapter Screw	316 SS
11. Handle Adapter	ASTM A366 Steel with Vinyl Grip
12. Stem Bearing	RPTFE
13. Stop	ASTM A108 Type 1215
14. Stop Screw	SAE J429 Grade 2
15. Lock Plate	ASTM A366 Steel
16. Body Seal	RPTFE
17. Grounding Spring	SS
18. Body Joint Stud	ASTM A193 Grade B7
19. Body Joint Nut	ASTM A194 Grade 2H
20. Pipe Handle	Galvanized Steel (not shown)

VARIATIONS AVAILABLE:

88A-740 Series (316 SS Ball & Stem)

88A-730 Series (Ni-Cu Ball & Stem)

OPTIONS AVAILABLE:

(SUFFIX)	OPTION
-01	Standard
-14	Side Vented Ball (Uni-Directional)
-21	UHMWPE Seats
-24	Fire Safe (Graphite Packing and Seal)
-35	PTFE Seats and Seals
-49	Assembled Dry
-59	SS External Trim
-60	Grounded Ball and Stem
-65	MPTFE Seats and Graphite Packing
-67	Cleaned For Industrial Gases
-69	Drilled and Tapped Purge Ports with Plugs
-70	Extended Bonnet
-73	316 SS Spiral Wound Gaskets w/PTFE Filler
-74	316 SS Spiral Wound Gaskets w/Graphite Filler
-76	Live Loaded 87A/88A Series (Lever)
-80	Multi-Seal (Super TFE) 87A/88A Series
-MG-	Gear Operator with Standard Handwheel
-MH-	Gear Operator with Standard Handwheel & Locking Device
-MJ-	Gear Operator with Oversize Handwheel
-MK-	Gear Operator with Oversize Handwheel & Locking Device

**For Pressure/Temperature Ratings,
Refer to Page M-9, Graph No. 5**

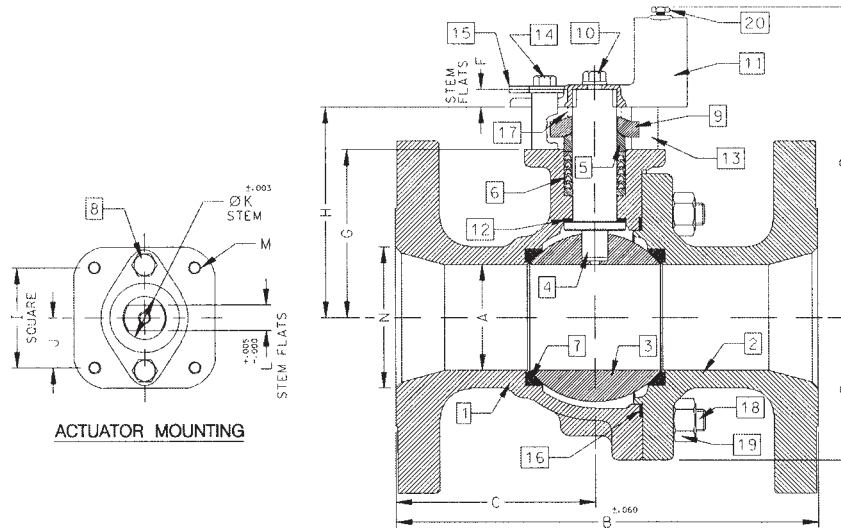

NUMBER	SIZE	A	B	C	D	E	F	G	H	I	J	K	L	M	N	WT.
88A-70A-01	4"	3.00	12.00	5.68	8.80	4.06	0.50	4.75	5.95	2.840	1.420	1.250	0.725	3/8-16	4.00	95.0
88A-70C-01	6"	4.00	15.88	7.38	9.99	5.25	0.50	5.94	7.13	2.840	1.420	1.250	0.725	3/8-16	6.00	187.0
88A-70E-01	8"	6.00	19.75	9.00	13.73	7.30	1.00	7.75	9.48	4.596	2.298	2.000	1.375	3/4-10	8.00	400.0



88A-700 Series

Carbon Steel ANSI Class 300 Flanged Std. Port Ball Valve - 10"

STANDARDS COMPLIANCE

Refer to page D-A

STANDARD FEATURES

Refer to page D-A

MATERIALS OF CONSTRUCTION

Description	Material
1. Body	ASTM A216 WCB
2. Retainer	ASTM A216 WCB
3. Ball	ASTM A108 Type 1215 or A216 WCB Chrome Plated
4. Stem	ASTM A108 Type 1215
5. Packing Gland	ASTM A108 Type 1215
6. Stem Seals	PTFE
7. Seats	RPTFE
8. Gland Screws	ASTM A193 B7
9. Gland Plate	316 SS
10. Stem Bearing	RPTFE
11. Body Seal	RPTFE
12. Body Joint Stud	ASTM A193 Grade B7
13. Body Joint Nut	ASTM A194 Grade 2H

VARIATIONS AVAILABLE:

88A-730 Series (Ni-Cu Ball & Stem)

88A-740 Series (316 SS Ball & Stem)

OPTIONS AVAILABLE:

(SUFFIX)	OPTION
-01-	Standard
-14-	Side Vented Ball (Uni-Directional)
-21-	UHMWPE Seats
-24-	Fire Safe (Graphite Packing and Seal)
-35-	PTFE Seats and Seals
-49-	Assembled Dry
-57-	Oxygen Cleaned
-60-	Grounded Ball and Stem
-65-	MPTFE Seats and Graphite Packing
-67-	Cleaned For Industrial Gases
-69-	Drilled and Tapped Purge Port with Plugs
-70-	Extended Bonnet
-76-	Live Loaded 87A/88A Series (Lever)
-80-	Multi-Seal (Super TFE) 87A/88A Series
-MG-	Gear Operator with Standard Handwheel
-MH-	Gear Operator with Standard Handwheel & Locking Device
-MJ-	Gear Operator with Oversize Handwheel
-MK-	Gear Operator with Oversize Handwheel & Locking Device

**For Pressure/Temperature Ratings,
Refer to Page M-9, Graph No. 5**

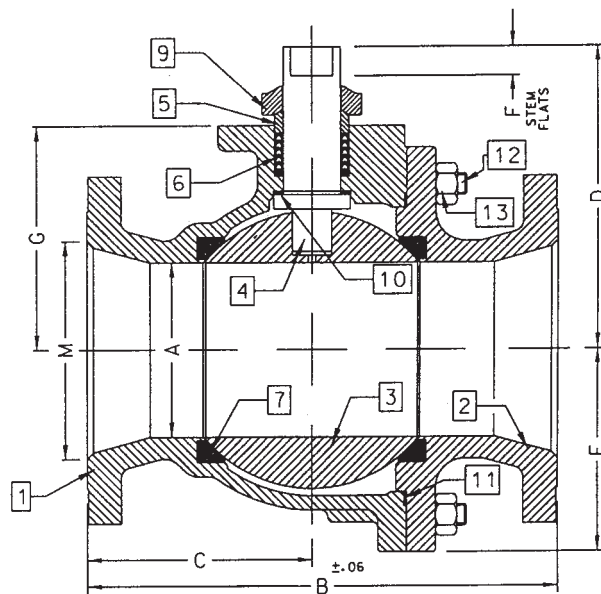
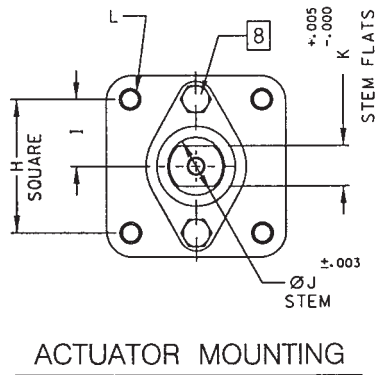

NUMBER	SIZE	A	B	C	D	E	F	G	H	I	J	K	L	M
88A-70G-01	10"	8.00	22.38	10.69	12.83	9.56	1.00	10.22	4.596	2.298	2.000	1.375	3/4-10	10.00



88A-900 Series

Carbon Steel ANSI Class 300 Flanged Full Port Ball Valve - 1/2" through 1"

STANDARDS COMPLIANCE

Refer to page D-A

MATERIALS OF CONSTRUCTION

Description (1/2" & 3/4" Valves)	Material
1. Body	ASTM A216 WCB
2. Retainer	ASTM A108 Type 1215
3. Ball	ASTM A108 Type 1215
4. Stem	ASTM A108 Type 1215
5. Packing Gland	ASTM A108 Type 1215
6. Stem Seals	PTFE
7. Seats	RPTFE
8. Stem Nut	300 Series Stainless Steel
9. Lever	300 Series Stainless Steel w/Vinyl Grip
10. Stem Bearing	RPTFE
11. Stop	300 Series Stainless Steel
12. Body Seal	RPTFE
13. Lock Washer	300 Series Stainless Steel
14. Grounding Spring	ASTM A313 Stainless Steel
15. Grounding Spring	ASTM A313 Stainless Steel

Description (1" Valves)	Material
1. Body	ASTM A216 WCB
2. Retainer	ASTM A108 Type 1215
3. Ball	ASTM A108 Type 1215 Chrome Plated
4. Stem	ASTM A108 Type 1215
5. Packing Gland	ASTM A108 Type 1215
6. Stem Seals	PTFE
7. Seats	RPTFE
8. Gland Screws	ASTM A193 B7
9. Gland Plate	302 or 304 SS
10. Stem Nut	316 SS
11. Lever	ASTM A366 Steel with Vinyl Grip
12. Stem Bearing	RPTFE
13. Stop	ASTM A108 Type 1215
14. Stop Screw	SAE J429 Grade 2
15. Lock Plate	ASTM A366 Steel
16. Body Seal	RPTFE
17. Lockwasher	302 or 304 SS
18. Grounding Spring	SS

STANDARD FEATURES

Refer to page D-A

VARIATIONS AVAILABLE:

88A-940 Series (316 SS Ball & Stem)

88A-930 Series (Ni-Cu Ball & Stem)

OPTIONS AVAILABLE:

(SUFFIX)	OPTION
-01-	Standard
-10-	SS Lever and Nut
-14-	Side Vented Ball (Uni-Directional)
-15-	Wheel Handle, Steel
-21-	UHMWPE Seats
-24-	Fire Safe (Graphite Packing and Seal)
-35-	PTFE Seats and Seals
-38-	PEEK Seats and Graphite Packing
-49-	Assembled Dry
-60-	Grounded Ball and Stem
-65-	MPTFE Seats and Graphite Packing
-67-	Cleaned For Industrial Gases
-69-	Drilled and Tapped Purge Port with Plug
-70-	4" Extended Bonnet
-73-	316 SS Spiral Wound Gaskets w/PTFE Filler
-74-	316 SS Spiral Wound Gaskets w/Graphite Filler
-76-	Live Loaded 87A/88A Series (Lever)
-80-	Multi-Seal (Super TFE) 87A/88A Series

For Pressure/Temperature Ratings, Refer to Page M-9, Graph No. 5

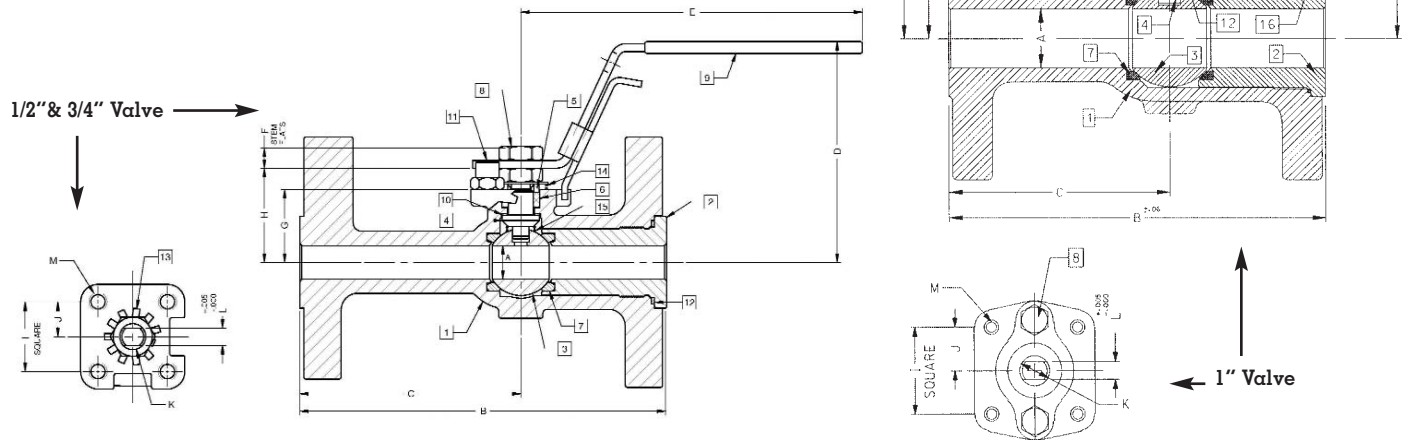

NUMBER	SIZE	A	B	C	D	E	F	G	H	I	J	K	L	M	WT.
88A-903-01	1/2"	0.50	5.50	3.31	3.31	5.11	0.30	1.09	1.38	1.000	0.500	0.375	0.245	10-24	7.0
88A-904-01	3/4"	0.75	6.00	3.56	3.89	5.53	0.36	1.65	1.99	1.392	0.696	0.500	0.287	1/4-20	9.0
88A-905-01	1"	1.00	6.50	3.82	4.62	6.53	0.47	1.62	2.15	1.392	0.696	0.500	0.287	1/4-20	10.5



88A-900 Series

Carbon Steel ANSI Class 300 Flanged Full Port Ball Valve - 1-1/2" through 2-1/2"

STANDARDS COMPLIANCE

Refer to page D-A

STANDARD FEATURES

Refer to page D-A

MATERIALS OF CONSTRUCTION

Description	Material
1. Body	ASTM A216 WCB
2. Retainer	ASTM A216 WCB
3. Ball	ASTM A216 WCB or A216 WCB Chrome Plated
4. Stem	ASTM A108 Type 1215
5. Packing Gland	ASTM A108 Type 1215
6. Stem Seals	PTFE
7. Seats	RPTFE
8. Gland Screws	ASTM A193 B7
9. Gland Plate	302 & 304 SS
10. Stem Nut	ASTM A194 Grade 8I
11. Lever	ASTM A366 Steel with Vinyl Grip
12. Stem Bearing	RPTFE
13. Stop	ASTM A108 Type 1215
14. Stop Screw	SAE J429 Grade 2
15. Lock Plate	ASTM A366 Steel
16. Body Seal	RPTFE
17. Grounding Spring	SS
18. Body Joint Stud	ASTM A193 Grade B7
19. Body Joint Nut	ASTM A194 Grade 2H
20. Lockwasher	302 or 304 SS

VARIATIONS AVAILABLE:

88A-940 Series (316 SS Ball & Stem)

88A-930 Series (Ni-Cu Ball & Stem)

OPTIONS AVAILABLE:

(SUFFIX)	OPTION
-01-	Standard
-14-	Side Vented Ball (Uni-Directional)
-15-	Wheel Handle, Steel
-21-	UHMWPE Seats
-24-	Fire Safe (Graphite Packing and Seal)
-35-	PTFE Seats and Seals
-38-	PEEK Seats and Graphite Packing
-49-	Assembled Dry
-59-	SS External Trim
-60-	Grounded Ball and Stem
-65-	MPTFE Seats and Graphite Packing
-67-	Cleaned For Industrial Gases
-69-	Drilled and Tapped Purge Ports with Plugs
-70-	4" Extended Bonnet
-73-	316 SS Spiral Wound Gaskets w/PTFE Filler
-74-	316 SS Spiral Wound Gaskets w/Graphite Filler
-76-	Live Loaded 87A/88A Series (Lever)
-80-	Multi-Seal (Super TFE) 87A/88A Series
-MG-	Gear Operator with Standard Handwheel
-MH-	Gear Operator with Standard Handwheel & Locking Device
-MJ-	Gear Operator with Oversize Handwheel
-MK-	Gear Operator with Oversize Handwheel & Locking Device

For Pressure/Temperature Ratings, Refer to Page M-9, Graph No. 5

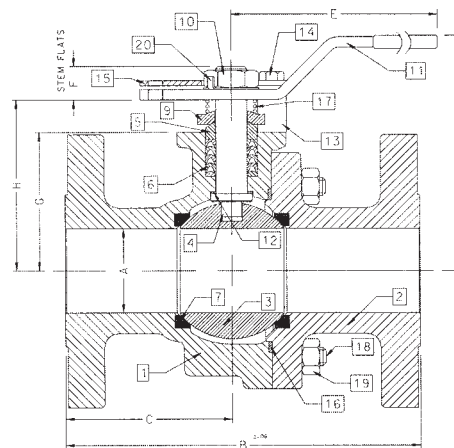
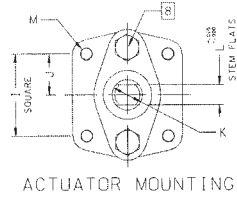

NUMBER	SIZE	A	B	C	D	E	F	G	H	I	J	K	L	M	WT.
88A-907-01	1-1/2"	1.50	7.50	3.50	4.62	6.65	0.72	2.41	3.09	1.949	0.974	0.625	0.412	5/16-18	21.0
88A-908-01	2"	2.00	8.50	4.00	5.61	8.41	0.80	3.31	4.08	1.949	0.974	0.750	0.477	5/16-18	37.0
88A-909-01	2-1/2"	2.50	9.50	4.44	6.24	8.41	0.80	3.94	4.71	1.949	0.974	0.750	0.477	5/16-18	57.0



88A-900 Series

Carbon Steel ANSI Class 300 Flanged Full Port Ball Valve - 3" through 6"

STANDARDS COMPLIANCE

Refer to page D-A

STANDARD FEATURES

Refer to page D-A

MATERIALS OF CONSTRUCTION

Description	Material
1. Body	ASTM A216 WCB
2. Retainer	ASTM A216 WCB
3. Ball	ASTM A216 WCB or A216 WCB Chrome Plated
4. Stem	ASTM A108 Type 1215
5. Packing Gland	ASTM A108 Type 1215
6. Stem Seals	PTFE
7. Seats	RPTFE
8. Gland Screws	ASTM A193 B7
9. Gland Plate	316 SS
10. Adapter Screw	316 SS
11. Handle Adapter	ASTM A366 Steel with Vinyl Grip
12. Stem Bearing	RPTFE
13. Stop	ASTM A108 Type 1215
14. Stop Screw	SAE J429 Grade 2
15. Lock Plate	ASTM A366 Steel
16. Body Seal	RPTFE
17. Grounding Spring	SS
18. Body Joint Stud	ASTM A193 Grade B7
19. Body Joint Nut	ASTM A194 Grade 2H
20. Pipe Handle	Galvanized Steel (not shown)

VARIATIONS AVAILABLE:

88A-940 Series (316 SS Ball & Stem)

88A-930 Series (Ni-Cu Ball & Stem)

OPTIONS AVAILABLE:

(SUFFIX)	OPTION
-01-	Standard
-14-	Side Vented Ball (Uni-Directional)
-21-	UHMWPE Seats
-24-	Fire Safe (Graphite Packing and Seal)
-35-	PTFE Seats and Seals
-38-	PEEK Seats and Graphite Packing
-49-	Assembled Dry
-59-	SS External Trim
-60-	Grounded Ball and Stem
-65-	MPTFE Seats and Graphite Packing
-67-	Cleaned For Industrial Gases
-69-	Drilled and Tapped Purge Ports with Plugs
-70-	4" Extended Bonnet
-73-	316 SS Spiral Wound Gaskets w/PTFE Filler
-74-	316 SS Spiral Wound Gaskets w/Graphite Filler
-76-	Live Loaded 87A/88A Series (Lever)
-80-	Multi-Seal (Super TFE) 87A/88A Series
-MG-	Gear Operator with Standard Handwheel
-MH-	Gear Operator with Standard Handwheel & Locking Device
-MJ-	Gear Operator with Oversize Handwheel
-MK-	Gear Operator with Oversize Handwheel & Locking Device

**For Pressure/Temperature Ratings,
Refer to Page M-9, Graph No. 5**

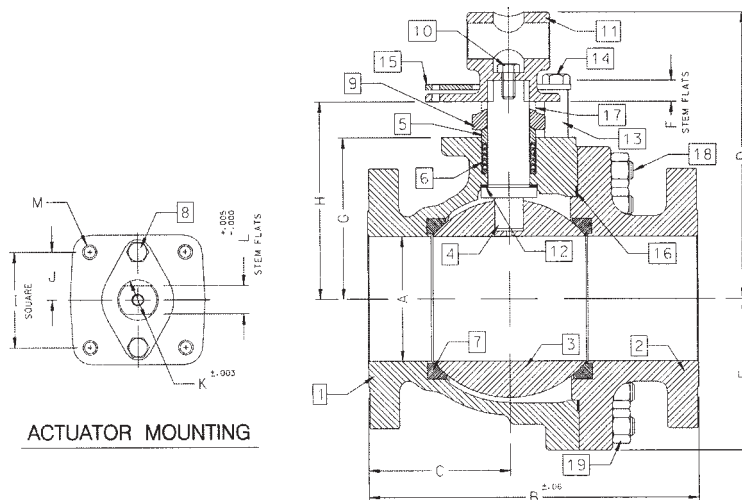

NUMBER	SIZE	A	B	C	D	E	F	G	H	I	J	K	L	M	WT.
88A-900-01	3"	3.00	11.12	5.24	8.80	4.06	0.50	4.75	5.95	2.840	1.420	1.250	0.725	3/8-16	78.0
88A-90A-01	4"	4.00	12.00	5.44	9.99	5.25	0.50	5.94	7.13	2.840	1.420	1.250	0.725	3/8-16	133.0
88A-90C-01	6"	6.00	15.88	6.82	13.73	7.30	1.00	7.75	9.48	4.596	2.296	2.000	1.375	3/4-10	329.0



88A-900 Series

Carbon Steel ANSI Class 300 Flanged Full Port Ball Valve - 8" through 12"

STANDARDS COMPLIANCE

Refer to page D-A

STANDARD FEATURES

Refer to page D-A

MATERIALS OF CONSTRUCTION

Description	Material
1. Body	ASTM A216 WCB
2. Retainer	ASTM A216 WCB
3. Ball	ASTM A108 Type 1215 or A216 WCB
4. Stem	ASTM A108 Type 1215
5. Packing Gland	ASTM A108 Type 1215
6. Stem Seals	PTFE
7. Seats	RPTFE
8. Gland Screws	ASTM A193 B7
9. Gland Plate	316 SS
10. Stem Bearing	RPTFE
11. Body Seal	RPTFE
12. Body Joint Stud	ASTM A193 Grade B7
13. Body Joint Nut	ASTM A194 Grade 2H

VARIATIONS AVAILABLE:

- 88A-930 Series (Ni-Cu Ball & Stem)
- 88A-940 Series (316 SS Ball & Stem)

OPTIONS AVAILABLE:

(SUFFIX)	OPTION
-01-	Standard
-14-	Side Vented Ball (Uni-Directional)
-21-	UHMWPE Seats
-24-	Fire Safe (Graphite Packing and Seal)
-35-	PTFE Seats and Seals
-49-	Assembled Dry
-60-	Grounded Ball and Stem
-65-	MPTFE Seats and Graphite Packing
-67-	Cleaned for Industrial Gas - CS Valves
-69-	Drilled and Tapped Purge Ports with Plugs
-70-	Extended Bonnet (8" Only)
-76-	Live Loaded 87A/88A Series (Lever)
-80-	Multi-Seal (Super TFE) 87A/88A Series
-MG-	Gear Operator with Standard Handwheel
-MH-	Gear Operator with Standard Handwheel & Locking Device
-MJ-	Gear Operator with Oversize Handwheel
-MK-	Gear Operator with Oversize Handwheel & Locking Device

For Pressure/Temperature Ratings, Refer to Page M-9, Graph No. 5

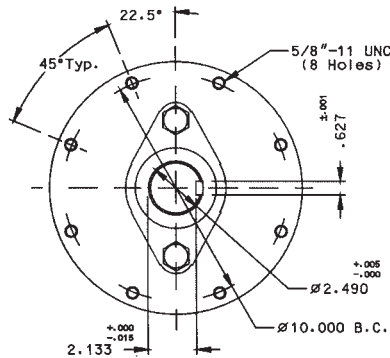

ACTUATOR MOUNTING: 10" & 12"

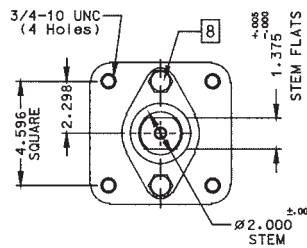

ACTUATOR MOUNTING: 8"

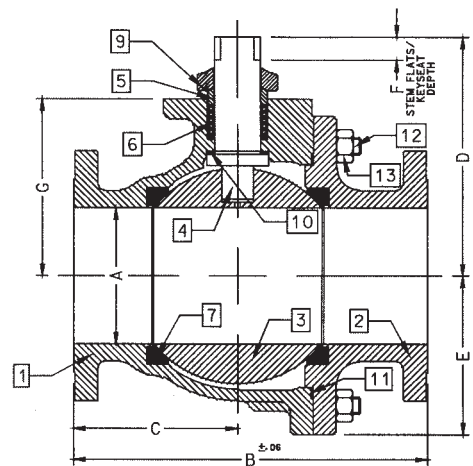

NUMBER	SIZE	A	B	C	D	E	F	G
88A-90E-01	8"	8.00	19.75	9.38	12.83	9.56	1.00	10.22
88A-90G-01	10"	10.00	22.38	10.95	18.57	11.33	2.31	12.80
88A-90H-01	12"	12.00	25.50	12.84	20.31	13.40	2.31	14.92



88B-100 Series

Carbon Steel ANSI Class 150 Flanged Std. Port Ball Valve - 3"

STANDARDS COMPLIANCE

Refer to page D-A

STANDARD FEATURES

Refer to page D-A

MATERIALS OF CONSTRUCTION

Description	Material
1. Body	ASTM A216-WCB
2. Retainer	ASTM A108 Type 1215
3. Ball	ASTM A108 Type 1215 Chrome Plated
4. Stem	ASTM A108 Type 1215 Chrome Plated
5. Packing Gland	ASTM A108 Type 1215
6. Stem Seals	PTFE
7. Seats	RPTFE
8. Gland Screws	ASTM A193 B7
9. Gland Plate	316 SS
10. Stem Nut	18-8 SS
11. Lever	316 SS with Vinyl Grip
12. Stem Bearing	RPTFE
13. Stop	ASTM A108 Type 1215
14. Stop Screw	SAE J429 Grade 2
15. Lock Plate	ASTM A366 Steel
16. Body Seal	RPTFE
17. Grounding Spring	SS
18. Lockwasher	302 or 304 SS

VARIATIONS AVAILABLE:

88B-130 Series (Ni-Cu Ball & Stem)

88B-140 Series (316 SS Ball & Stem)

OPTIONS AVAILABLE:

(SUFFIX)	OPTION
-14-	Side Vented Ball (Uni-Directional)
-21-	UHMWPE Seats
-24-	Fire Safe (Graphite Packing and Seal)
-35-	PTFE Seats and Seals
-38-	PEEK Seats and Graphite Packing (3" Only)
-49-	Assembled Dry
-57-	Oxygen Cleaned
-60-	Grounded Ball and Stem
-65-	MPTFE Seats and Graphite Packing
-69-	Drilled and Tapped Purge Ports with Plugs
-70-	Extended Bonnet
-76-	Live Loaded 87A/88A Series (Lever)
-80-	Multi-Seal (Super TFE) 87A/88A Series
-MG-	Gear Operator with Standard Handwheel
-MH-	Gear Operator with Standard Handwheel & Locking Device
-MJ-	Gear Operator with Oversize Handwheel
-MK-	Gear Operator with Oversize Handwheel & Locking Device

**For Pressure/Temperature Ratings,
Refer to Page M-7, Graph No. 1**

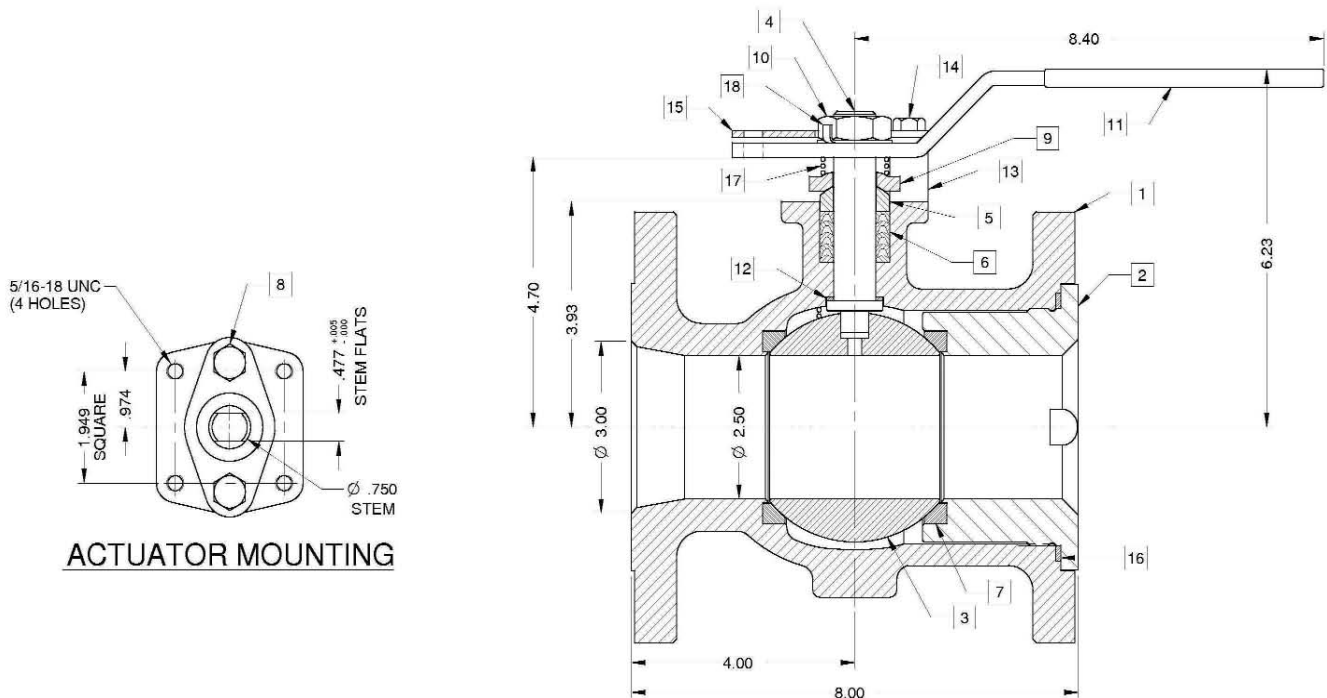



88B-100 Series

Carbon Steel ANSI Class 150 Flanged Std. Port Ball Valve 4"-10" Short Pattern

STANDARDS COMPLIANCE

Refer to page D-A

STANDARD FEATURES

Refer to page D-A

MATERIALS OF CONSTRUCTION

Description	Material
1. Body	ASTM A216-WCB
2. Retainer	ASTM A108 Type 1215
3. Ball	ASTM A108 Type 1215 (Chrome Plate)
4. Stem	ASTM A108 Type 1215 (Chrome Plate)
5. Packing Gland	ASTM A108 Type 1215
6. Stem Seals	PTFE
7. Seats	RPTFE
8. Gland Screws	ASTM A193 B7
9. Gland Plate	316 SS
10. Adapter Screw	18-8 SS
11. Handle Adapter	316 SS
12. Stem Bearing	RPTFE
13. Stop	ASTM A108 Type 1215
14. Stop Screw	SAE J429 Grade 2
15. Lock Plate	ASTM A366 Stainless Steel
16. Body Seal	RPTFE
17. Lockwasher	302 or 304 SS
18. Grounding Spring	SS
19. Adapter Screw	18-8 SS

OPTIONS AVAILABLE:

(SUFFIX)	OPTION
-14-	Side Vented Ball (Uni-Directional)
-21-	UHMWPE Seats
-24-	Fire Safe (Graphite Packing and Seal)
-35-	PTFE Seats and Seals
-38-	PEEK Seats and Graphite Packing
-49-	Assembled Dry
-57-	Oxygen Cleaned (Stainless Steel Valves Only)
-60-	Grounded Ball and Stem
-65-	MPTFE Seats and Graphite Packing
-69-	Drilled and Tapped Purge Ports with Plugs
-70-	Extended Bonnet
-80-	Multi-Seal (Super TFE)
-MG-	Gear Operator with Standard Handwheel
-MH-	Gear Operator with Standard Handwheel & Locking Device
-MJ-	Gear Operator with Oversize Handwheel
-MK-	Gear Operator with Oversize Handwheel & Locking Device

VARIATIONS AVAILABLE:

- 88B-130 Series (Ni-Cu Ball & Stem)
- 88B-140 Series (316 SS Ball & Stem)

**For Pressure/Temperature Ratings,
Refer to Page M-7, Graph No. 1**

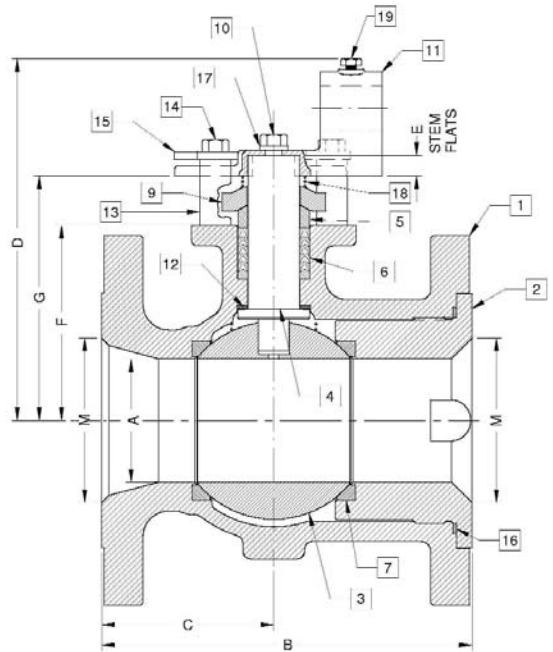
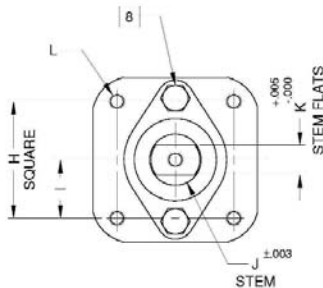

NUMBER	SIZE	A	B	C	D	E	F	G	H	I	J	K	L	M	WT.
88B-10A-01	4"	3.00	9.00	4.18	8.80	0.50	4.75	5.95	2.840	1.420	1.250	0.725	3/8-16	4.00	72
88B-10C-01	6"	4.00	10.50	5.25	9.99	0.50	5.94	7.13	2.840	1.420	1.250	0.725	3/8-16	6.00	110
88B-10E-01	8"	6.00	11.50	5.75	13.61	1.00	7.63	9.36	4.596	2.298	2.000	1.375	3/4-10	8.00	210
88B-10G-01	10"	8.00	13.00	6.50	N/A	1.00	9.50	11.23	4.596	2.298	2.000	1.375	3/4-10	10.0	350



87-100 Series

Stainless Steel ANSI Class 150 Flanged Ball Valve

ANSI Class 150 Flanged Ends, 275 psig WOG, Cold Non-Shock. 150 psig Saturated Steam.
 Vacuum Service to 29 inches Hg.
 Federal Specification: WW-V-35C, Type: II, Composition: SS, Style: 3.

FEATURES (1/2" to 1")

- Investment cast body
- Adjustable packing gland
- RPTFE seats and seals
- Actuator mounting provisions
- (-24) Certified to API standard 607, 4th Edition
- Meets NACE MR-01-75
- Unibody construction
- Corrosion resistant
- Blow-out-proof stem design
- Field repairable
- Positive shut-off

STANDARD MATERIAL LIST

1. Lever and grip	304 SS w/vinyl	7. Packing gland	A276-316
2. Stem packing	RPTFE (1/2" to 1")	8. Stem	A276-316
3. Stem bearing	RPTFE	9. Lever nut	304 SS
4. Ball	A276-316	10. Body	A351-CF8M
5. Seat (2)	RPTFE	11. Body seal	PTFE
6. Retainer	A276-316 or A351-CF8M		

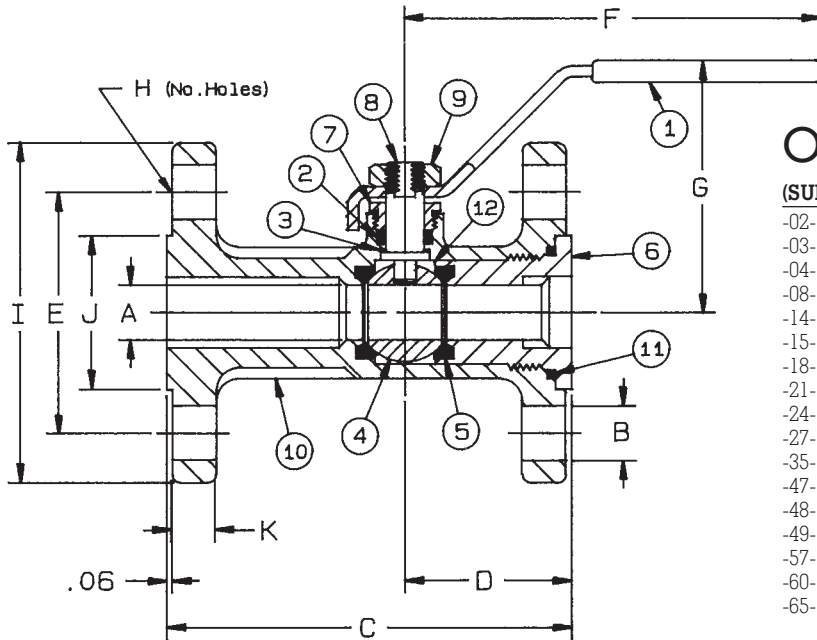

OPTIONS AVAILABLE:

(SUFFIX)	OPTION	SIZES
-02-	Static Grounded	1/2" to 1"
-03-	1-1/4" CS Stem Extension	1/2" to 1"
-04-	2-1/4" CS Stem Extension	1/2" to 1"
-08-	90° Reversed Stem	1/2" to 1"
-14-	Vented Ball (see page J-2)	1/2" to 1"
-15-	Round Handle	1/2" to 1"
-18-	Plain Yellow Grip	1/2" to 1"
-21-	UHMWPE Seats (Non-PTFE)	1/2" to 1"
-24-	Graphite Stem Packing	1/2" to 1"
-27-	Latch Lock Lever	1/2" to 1"
-35-	PTFE Trim	1/2" to 1"
-47-	SS Oval Latch-Lock Handle	1/2" to 1"
-48-	SS Oval Handle	1/2" to 1"
-49-	Assembled Dry	1/2" to 1"
-57-	Cleaned For Gaseous Oxygen	1/2" to 1"
-60-	Static Grounded Ball & Stem	1/2" to 1"
-65-	Multifill Seats & Graphite Packing	1/2" to 1"

Contact factory for actuator mounting dimensions.

For Pressure/Temperature Ratings, Refer to Page M-7, Graph No. 2

SS ANSI CLASS 150 FLANGED BALL VALVE (1/2" to 1")

NUMBER	SIZE	A	B	C	D	E	F	G	H	I	J	K	Wt.
87-103-01	1/2"	.50	.62	4.25	1.87	2.37	4.41	2.56	4	3.50	1.38	.43	3.2
87-104-01	3/4"	.62	.62	4.62	1.91	2.75	4.75	2.91	4	3.88	1.69	.50	4.6
87-105-01	1"	.87	.62	5.00	1.94	3.12	4.75	3.10	4	4.25	2.00	.50	6.1



88-100 Series

Carbon Steel ANSI Class 150 Flanged Ball Valve

ANSI Class 150 Flanged Ends, 285 psig WOG, Cold Non-Shock. 150 psig Saturated Steam.

Vacuum Service to 29 inches Hg.

Federal Specification: WW-V-35C, Type: II, Composition: CS, Style: 3.

FEATURES (1/2" to 1")

- Investment cast body
- Adjustable packing gland
- RPTFE seats and seals
- (-24) Certified to API standard 607, 4th Edition
- Positive shut-off
- Unibody construction
- Corrosion resistant
- Blow-out-proof stem design
- Field repairable
- Nitride corrosion protection
- Actuator mounting provisions

STANDARD MATERIAL LIST

1. Lever and grip	Steel, zinc plated w/vinyl	7. Packing gland	A108-CS
2. Stem packing	RPTFE	8. Stem	A108-CS
3. Stem bearing	RPTFE	9. Lever nut	Steel, zinc plated
4. Ball	A108-CS chrome plated	10. Body	A216-WCB
5. Seat (2)	RPTFE	11. Body seal	PTFE
6. Retainer	A108-CS		

VARIATIONS AVAILABLE:

88-140 Series (316 SS Ball & Stem)

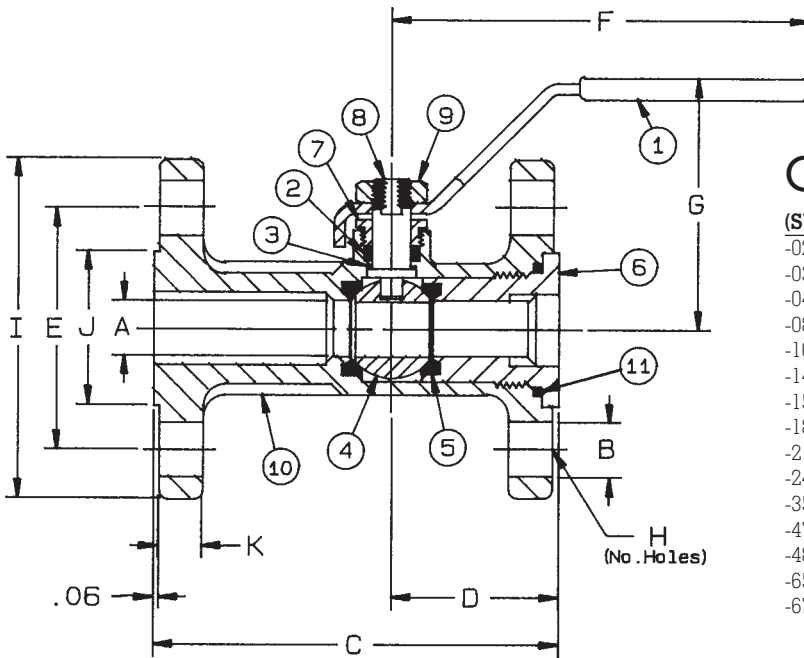

OPTIONS AVAILABLE:

(SUFFIX)	OPTION	SIZES
-02-	Stem Grounded	1/2" to 1"
-03-	1-1/4" CS Stem Extension	1/2" to 1"
-04-	2-1/4" CS Stem Extension	1/2" to 1"
-08-	90° Reversed Stem	1/2" to 1"
-10-	SS Lever & Nut	1/2" to 1"
-14-	Side Vented Ball (Uni-Directional)	1/2" to 1"
-15-	Wheel Handle, Steel	1/2" to 1"
-18-	Plain Yellow Grip	1/2" to 1"
-21-	UHMWPE Trim (Non-PTFE)	1/2" to 1"
-24-	Graphite Packing	1/2" to 1"
-35-	VTFE Trim	1/2" to 1"
-47-	SS Oval Latch-Lock Handle & Nut	1/2" to 1"
-48-	SS Oval Handle (No Latch) & Nut	1/2" to 1"
-65-	Multifill Seats & Graphite Packing	1/2" to 1"
-67-	Cleaned For Industrial Gas - CS Valves	1/2" to 1"

Contact factory for actuator mounting dimensions.

**For Pressure/Temperature Ratings,
Refer to Page M-7, Graph No. 1**

CARBON STEEL ANSI CLASS 150 FLANGED BALL VALVE (1/2" to 1")

NUMBER	SIZE	A	B	C	D	E	F	G	H	I	J	K	Wt.
88-103-01	1/2"	.50	.62	4.25	1.87	2.37	4.37	2.56	4	3.50	1.38	.43	3.2
88-104-01	3/4"	.62	.62	4.62	1.91	2.75	4.87	2.93	4	3.88	1.69	.50	4.5
88-105-01	1"	.87	.62	5.00	1.94	3.12	4.87	3.12	4	4.25	2.00	.50	6.1



87A-500 Series

Alloy 20 ANSI Class 150 Flanged Full Port Ball Valve - 1/2" through 1"

STANDARDS COMPLIANCE

Refer to page D-A

STANDARD FEATURES

Refer to page D-A

MATERIALS OF CONSTRUCTION

Description	Material
1. Body	ASTM A351 CN7M
2. Retainer	ASTM B473 (UNS N08020)
3. Ball	ASTM B473 (UNS N08020)
4. Stem	ASTM B473 (UNS N08020)
5. Packing Gland	ASTM A276 Type 316
6. Stem Seals	PTFE
7. Seats	RPTFE
8. Gland Screws	ASTM A193 B8 Class 1
9. Gland Plate	302 or 304 SS
10. Stem Nut	316 SS
11. Lever	302 or 304 SS with Vinyl Grip
12. Stem Bearing	RPTFE
13. Stop	ASTM A276 Type 316
14. Stop Screw	18-8 SS
15. Lock Plate	302 or 304 SS
16. Body Seal	RPTFE
17. Lockwasher	302 or 304 SS
18. Grounding Spring	SS

OPTIONS AVAILABLE:

(SUFFIX)	OPTION
-01-	Standard (Locking and Grounded)
-14-	Side Vented Ball (Uni-Directional)
-15-	Wheel Handle, Steel
-21-	UHMWPE Seats
-24-	Fire Safe (Graphite Packing and Seal)
-35-	PTFE Seats and Seals
-38-	PEEK Seats and Graphite Packing
-49-	Assembled Dry
-57-	Oxygen Cleaned
-65-	MPTFE Seats and Graphite Packing
-69-	Drilled and Tapped Purge Port with Plug
-70-	4" Extended Bonnet
-80-	Multi-Seal (Super TFE) 87A/88A Series

For Pressure/Temperature Ratings, Refer to Page M-14, Graph No. 18

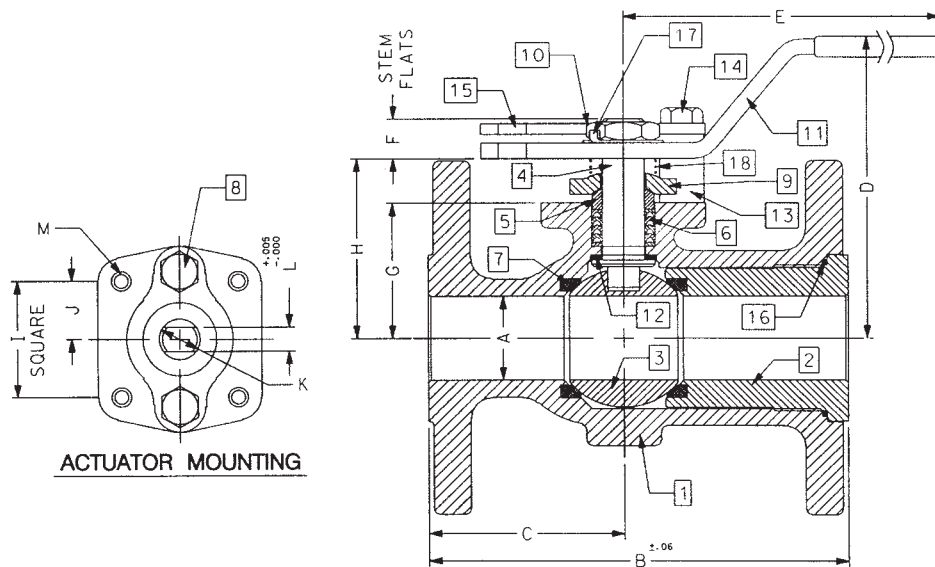

NUMBER	SIZE	A	B	C	D	E	F	G	H	I	J	K	L	M	WT.
87A-503-01	1/2"	0.500	4.25	2.06	3.31	5.11	0.30	1.09	1.41	1.000	0.500	0.375	0.245	10-24	5.0
87A-504-01	3/4"	0.750	4.62	2.18	3.89	5.53	0.36	1.65	1.99	1.392	0.696	0.500	0.287	1/4-20	6.0
87A-505-01	1"	1.00	5.00	2.32	4.62	6.53	0.47	1.62	2.15	1.392	0.696	0.500	0.287	1/4-20	7.0



87A-400 Series

Alloy 20 ANSI Class 150 Flanged Standard Port Ball Valve - 1-1/2" through 2"

STANDARDS COMPLIANCE

Refer to page D-A

STANDARD FEATURES

Refer to page D-A

MATERIALS OF CONSTRUCTION

Description	Material
1. Body	ASTM A351 CN7M
2. Retainer	ASTM B473 (UNS N08020)
3. Ball	ASTM B473 (UNS N08020)
4. Stem	ASTM B473 (UNS N08020)
5. Packing Gland	ASTM A276 Type 316
6. Stem Seals	PTFE
7. Seats	RPTFE
8. Gland Screws	ASTM A193 B8 Class 1
9. Gland Plate	302 or 304 SS
10. Stem Nut	316 SS
11. Lever	302 or 304 SS with Vinyl Grip
12. Stem Bearing	RPTFE
13. Stop	ASTM A276 Type 316
14. Stop Screw	18-8 SS
15. Lock Plate	302 or 304 SS
16. Body Seal	RPTFE
17. Lockwasher	302 or 304 SS
18. Grounding Spring	SS

OPTIONS AVAILABLE:

(SUFFIX)	OPTION
-01-	Standard
-14-	Side Vented Ball (Uni-Directional)
-15-	Wheel Handle, Steel
-21-	UHMWPE Seats
-24-	Fire Safe (Graphite Packing and Seal)
-35-	PTFE Seats and Seals
-38-	PEEK Seats and Graphite Packing
-49-	Assembled Dry
-57-	Oxygen Cleaned
-60-	Grounded Ball and Stem
-65-	MPTFE Seats and Graphite Packing
-69-	Drilled and Tapped Purge Port with Plug
-80-	Multi-Seal (Super TFE) 87A/88A Series

For Pressure/Temperature Ratings, Refer to Page M-14, Graph No. 18

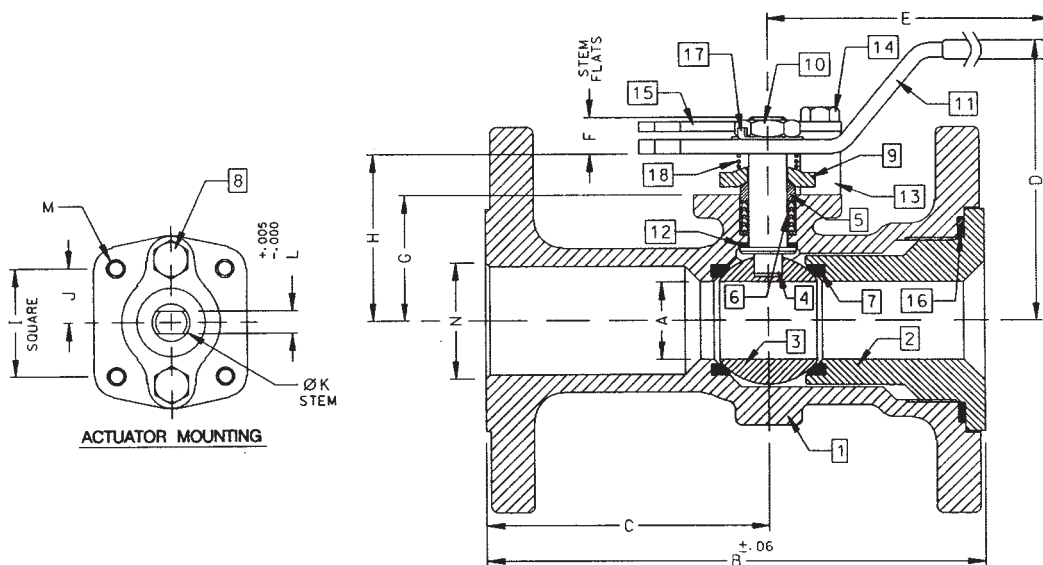

NUMBER	SIZE	A	B	C	D	E	F	G	H	I	J	K	L	M	N	WT.
87A-407-01A	1-1/2"	1.00	6.50	3.50	4.85	6.53	0.47	1.85	2.38	1.392	0.696	0.500	0.287	1/4-20	1.50	9.0
87A-408-01	2"	1.50	7.00	3.69	4.62	6.65	0.72	2.41	3.09	1.949	0.974	0.625	0.412	5/16-18	2.00	18.0



87A-400 Series

Alloy 20 ANSI Class 150 Flanged Standard Port Ball Valve - 3"

STANDARDS COMPLIANCE

Refer to page D-A

STANDARD FEATURES

Refer to page D-A

MATERIALS OF CONSTRUCTION

Description	Material
1. Body	ASTM A351 CN7M
2. Retainer	ASTM A351 CN7M
3. Ball	ASTM B473 (UNS N08020) or CN7M
4. Stem	ASTM B473 (UNS N08020)
5. Packing Gland	ASTM A276 Type 316
6. Stem Seals	PTFE
7. Seats	RPTFE
8. Gland Screws	ASTM A193 B8 Class 1
9. Gland Plate	316 SS
10. Stem Nut	18-8 SS
11. Lever	316 SS with Vinyl Grip
12. Stem Bearing	RPTFE
13. Stop	ASTM A276 Type 316
14. Stop Screw	316 SS
15. Lock Plate	302 or 304 SS
16. Body Seal	RPTFE
17. Grounding Spring	SS
18. Body Joint Stud	ASTM A193 Grade B8M
19. Body Joint Nut	ASTM A194 Grade 8
20. Lockwasher	302 or 304 SS

OPTIONS AVAILABLE:

(SUFFIX)	OPTION
-01-	Standard
-14-	Side Vented Ball (Uni-Directional)
-21-	UHMWPE Seats
-24-	Fire Safe (Graphite Packing and Seal)
-35-	PTFE Seats and Seals
-38-	PEEK Seats and Graphite Packing
-49-	Assembled Dry
-57-	Oxygen Cleaned
-60-	Grounded Ball and Stem
-65-	MPTFE Seats and Graphite Packing
-69-	Drilled and Tapped Purge Ports with Plugs
-70-	4" Extended Bonnet
-80-	Multi-Seal (Super TFE) 87A/88A Series
-MG-	Gear Operator with Standard Handwheel
-MH-	Gear Operator with Standard Handwheel & Locking Device
-MJ-	Gear Operator with Oversize Handwheel
-MK-	Gear Operator with Oversize Handwheel & Locking Device

For Pressure/Temperature Ratings, Refer to Page M-14, Graph No. 18

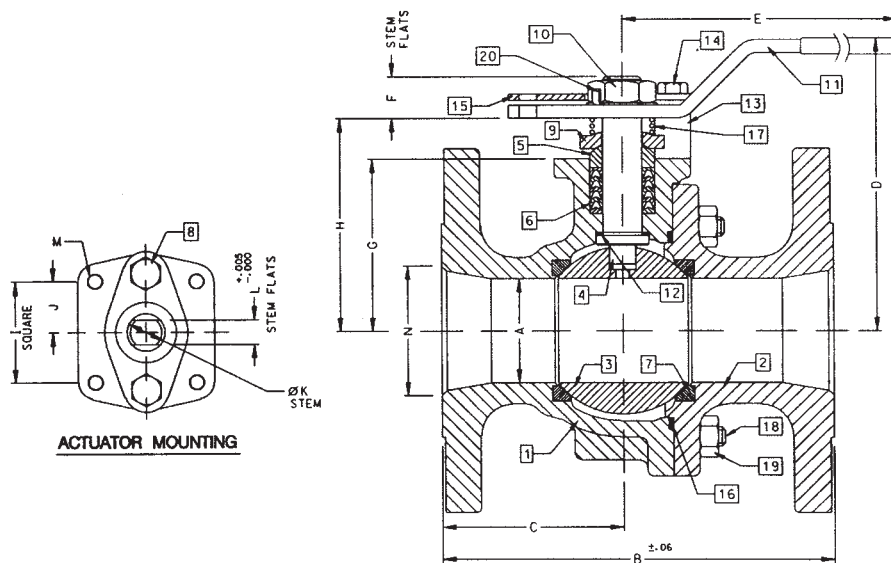

NUMBER	SIZE	A	B	C	D	E	F	G	H	I	J	K	L	M	N	WT.
87A-400-01	3"	2.50	8.00	3.51	6.24	8.41	0.80	3.94	4.71	1.949	0.974	0.750	0.477	5/16-18	3.00	34.3



87A-400 Series

Alloy 20 ANSI Class 150 Flanged Standard Port Ball Valve - 4"

STANDARDS COMPLIANCE

Refer to page D-A

STANDARD FEATURES

Refer to page D-A

MATERIALS OF CONSTRUCTION

Description	Material
1. Body	ASTM A351 CN7M
2. Retainer	ASTM A351 CN7M
3. Ball	ASTM B473 (UNS N08020) or CN7M
4. Stem	ASTM B473 (UNS N08020)
5. Packing Gland	ASTM A276 Type 316
6. Stem Seals	PTFE
7. Seats	RPTFE
8. Gland Screws	ASTM A193 B8 Class 1
9. Gland Plate	316 SS
10. Adapter Screw	18-8 SS
11. Handle Adapter	316 SS with Vinyl Grip
12. Stem Bearing	RPTFE
13. Stop	ASTM A276 Type 316
14. Stop Screw	316 SS
15. Lock Plate	302 or 304 SS
16. Body Seal	RPTFE
17. Grounding Spring	SS
18. Body Joint Stud	ASTM A193 Grade B8M
19. Body Joint Nut	ASTM A194 Grade 8
20. Adapter Screw	18-8 SS
21. Pipe Handle	Galvanized Steel (not shown)

OPTIONS AVAILABLE:

(SUFFIX)	OPTION
-01-	Standard
-14-	Side Vented Ball (Uni-Directional)
-21-	UHMWPE Seats
-24-	Fire Safe (Graphite Packing and Seal)
-35-	PTFE Seats and Seals
-49-	Assembled Dry
-57-	Oxygen Cleaned
-60-	Grounded Ball and Stem
-65-	MPTFE Seats and Graphite Packing
-69-	Drilled and Tapped Purge Ports with Plugs
-70-	4" Extended Bonnet
-80-	Multi-Seal (Super TFE) 87A/88A Series
-MG-	Gear Operator with Standard Handwheel
-MH-	Gear Operator with Standard Handwheel & Locking Device
-MJ-	Gear Operator with Oversize Handwheel
-MK-	Gear Operator with Oversize Handwheel & Locking Device

For Pressure/Temperature Ratings, Refer to Page M-14, Graph No. 18

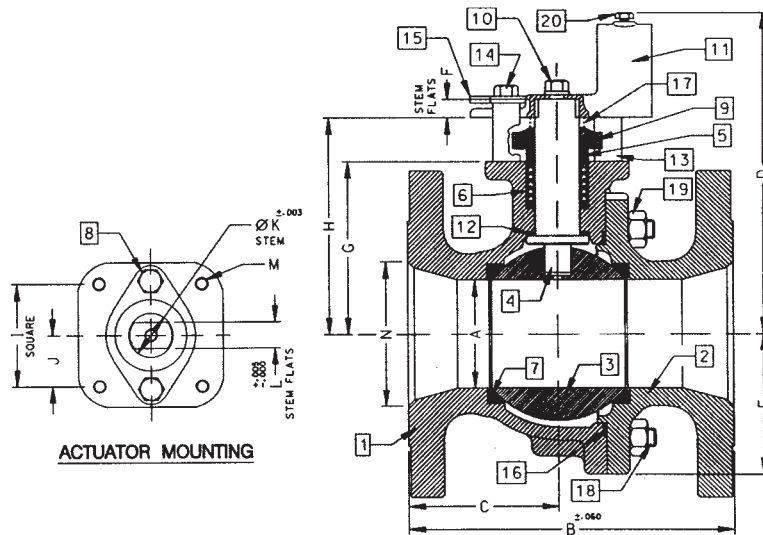

NUMBER	SIZE	A	B	C	D	E	F	G	H	I	J	K	L	M	N	WT.
87A-40A-01	4"	3.00	9.00	4.18	8.80	3.88	0.50	4.75	5.95	2.840	1.420	1.250	0.725	3/8-16	4.00	73.0