

SECTION B CONTENTS

THREE PIECE BALL VALVES

DESCRIPTION	PAGE
82-100 Series, Threaded Full Port Bronze	B-1
82-200 Series, Solder Full Port Bronze	B-2
83R-100 Series, Actuator Ready Threaded Full Port Carbon Steel	B-3, B-4
83R-200 Series, Actuator Ready Socket Weld Full Port Carbon Steel	B-5, B-6
83R-700 Series, Actuator Ready Butt-Weld Full Port Carbon Steel	B-7
85R-100 Series, Actuator Ready Threaded Stainless Steel	B-8
85R-200 Series, Actuator Ready Socket Weld Stainless Steel	B-9
86R-100 Series, Actuator Ready Threaded Full Port Stainless Steel	B-10, B-11
86R-200 Series, Actuator Ready Socket Weld Full Port Stainless Steel	B-12, B-13
86R-700 Series, Actuator Ready Butt-Weld Full Port Stainless Steel	B-14
401R-100 Series, Actuator Ready Threaded Full Port Alloy 20	B-15
401R-200 Series, Actuator Ready Socket Weld Full Port Alloy 20	B-16
83-300 Series, Threaded High Pressure Carbon Steel	B-17
83-400 Series, Socket Weld High Pressure Carbon Steel	B-18
83-500 Series, Threaded Full Port High Pressure Carbon Steel	B-19
83-600 Series, Socket Weld Full Port High Pressure Carbon Steel	B-20
85-100 Series, Threaded Stainless Steel	B-21
85-200 Series, Socket Weld Stainless Steel	B-22
86-500 Series, Threaded Full Port High Pressure Stainless Steel	B-23
86-600 Series, Socket Weld Full Port High Pressure Stainless Steel	B-24
86-900 Series, Butt-Weld Full Port High Pressure Stainless Steel	B-25
83A-140 Series, 3-Piece Full Port Carbon Steel	B-26
83A-240 Series, 3-Piece Full Port Carbon Steel Socket-Weld	B-27
83A-540 Series, 3-Piece Full Port Carbon Steel Butt-Weld	B-28
83B-140 Series, 3-Piece Full Port Carbon Steel	B-29
83B-240 Series 3-Piece Full Port Carbon Steel Socket-Weld	B-30
83B-540 Series, 3-Piece Full Port Carbon Steel Butt-Weld	B-31
86A-100 Series, 3-Piece Full Port Stainless Steel	B-32
86A-500 Series, 3-Piece Full Port Stainless Steel Butt-Weld	B-33
86A-200 Series 3-Piece Full Port Stainless Steel Socket-Weld	B-34
86A-500 Series 3-Piece Full Port Stainless Steel Butt-Weld	B-35
86B-100 Series 3-Piece Full Port Stainless Steel	B-36
86B-200 Series 3-Piece Full Port Stainless Steel Socket-Weld	B-37



82-100 Series

Bronze 3-Piece Full Port Ball Valve

Threaded, 600 psig WOG, Cold Non-Shock. 150 psig Saturated Steam.

Vacuum Service to 29 inches Hg.

Federal Specification: WW-V-35C, Type: II, Composition: BZ, Style: 1.

MSS SP-110; Ball Valve Threaded, Socket-Welding, Solder Joint, Grooved and Flared Ends.

FEATURES

- Full port configuration
- RPTFE seats and seals
- In-line repairable
- Blow-out-proof stem design
- Adjustable packing gland

STANDARD MATERIAL LIST

1. Lever and grip	Steel, zinc plated w/vinyl	10. Body bolt	Steel, zinc plated
2. Stem packing	RPTFE	11. Hex nut	Steel, zinc plated
3. Stem bearing	RPTFE	12. Body	B584-C84400
4. Ball	B16, chrome plated (except 3" & 4")		
5. Seat (2)	RPTFE		
6. End cap (2)	B16 (1/4" to 3/8")		
	B584-C84400 (1/2" to 4")		
7. Gland nut	B16		
8. Stem	B16 (except 3" & 4")		
9. Lever nut	Steel, zinc plated		

VARIATIONS AVAILABLE:

82-140 Series (316 SS Ball & Stem)

82-150 Series (Original Balancing Stop)

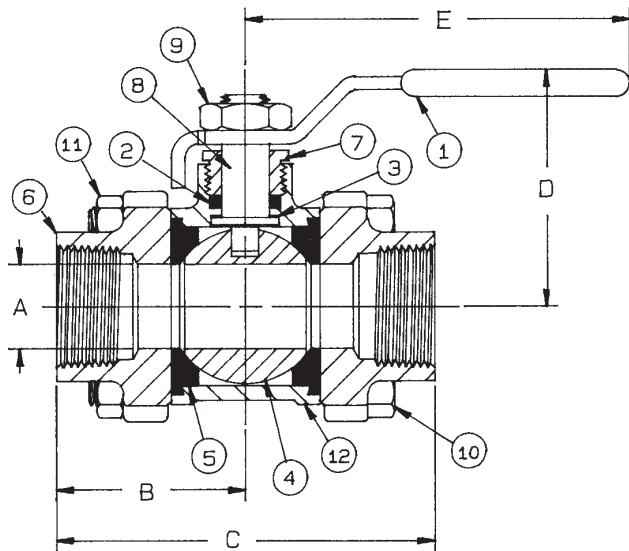

BRONZE 3-PIECE FULL PORT BALL VALVE

NUMBER	SIZE	A	B	C	D	E	Wt.
82-101-01	1/4"	.43	1.28	2.56	1.81	3.87	1.02
82-102-01	3/8"	.50	1.28	2.56	1.81	3.87	1.04
82-103-01	1/2"	.62	1.40	2.81	1.93	4.87	1.55
82-104-01	3/4"	.81	1.71	3.43	2.18	4.87	2.27
82-105-01	1"	1.00	1.93	3.87	2.62	5.50	3.28
82-106-01	1-1/4"	1.25	2.37	4.75	2.87	5.50	5.62
82-107-01	1-1/2"	1.50	2.62	5.25	3.37	8.00	8.07
82-108-01	2"	2.00	3.01	6.03	3.68	8.00	14.42
82-109-01	2-1/2"	2.50	3.62	7.25	5.14	9.75	26.61
82-140-01	3"	3.00	4.00	8.00	6.77	18.00	42.24
82-14A-01	4"	4.00	5.50	11.00	8.26	18.00	88.40

OPTIONS AVAILABLE:

(SUFFIX)	OPTION	SIZES
-02-	Static Grounded	1/4" to 4"
-03-	1-1/4" Stem Extension	1/4" to 2"
-04-	2-1/4" Stem Extension	1/4" to 2"
-05-	Plain Ball	1/4" to 4"
-07-	Tee Handle	1/4" to 2"
-08-	90° Reversed Stem	1/4" to 4"
-10-	SS Lever & Nut	1/4" to 4"
-14-	Vented Ball (see page J-2)	1/4" to 4"
-15-	Round Handle	1/4" to 2"
-16-	Vertical Chain Lever	1/2" to 2"
-18-	Plain Yellow Grip	1/4" to 2"
-19-	Lock Plate	1/4" to 4"
-20-	Slot Vented Ball	1/4" to 4"
-21-	UHMWPE Seats	1/4" to 4"
-23-	Tank Flange	2" ONLY
-24-	Graphite Stem Packing	1/4" to 4"
-27-	Latch Lock Lever	1/2" to 2"
-30-	CamLock Handle	1/4" to 1-1/4"
-32-	SS Tee Handle & Nut	1/4" to 2"
-35-	PTFE Trim	1/4" to 4"
-39-	SS Hi-Rise Locking Wheel Handle, SS Nut	1/4" to 1-1/4"
-40-	Cyl-Loc & Grounded	1/4" to 1/2"
-45-	Less Lever & Nut	1/4" to 4"
-46-	Latch-Lock Lever - Lock in Closed Position Only	1/2" to 2"
-47-	SS Oval Latch-Lock Handle & Nut	1/4" to 3/4"
-48-	SS Oval Handle (No Latch) & Nut	1/4" to 2"
-49-	Assembled Dry	1/4" to 4"
-50-	2-1/4" CS Locking Stem Extension	1/4" to 2"
-56-	Multifill Seats & Graphite Packing	1/4" - 4"
-57-	Oxygen Cleaned	1/4" to 4"
-58-	Chain Lever - Horizontal	1/2" to 2"
-59-	SS External Trim - 3-pc. Valves	1/4" to 4"
-60-	Grounded Ball & Stem	1/4" to 4"
-63-	NPT x Solder/Socket Weld	3/8" to 4"
-P01-	BSPP (Parallel) Thread Connection	1/4" to 4"
-T01-	BSPT (Tapered) Thread Connection	1/4" to 4"

**For Pressure/Temperature Ratings,
Refer to Page M-8, Graph No. 4**



82-200 Series

Bronze 3-Piece Full Port Solder End Ball Valve

Solder End, 600 psig WOG, Cold Non-Shock. 150 psig Saturated Steam.

Vacuum Service to 29 inches Hg.

Federal Specification: WW-V-35B, Type: II, Composition: BZ, Style: 1.

Designed For Soft Solder or Brazed Installation.

MSS SP-110; Ball Valve Threaded, Socket-Welding, Solder Joint, Grooved and Flared Ends.

FEATURES

- Full port configuration
- RPTFE seats and seals
- In-line repairable
- Blow-out-proof stem design
- Adjustable packing gland

STANDARD MATERIAL LIST

1. Lever and grip	Steel, zinc plated w/vinyl	10. Body bolt	Steel, zinc plated
2. Stem packing	RPTFE	11. Hex nut	Steel, zinc plated
3. Stem bearing	RPTFE	12. Body	B584-C84400
4. Ball	B16, chrome plated (except 3" & 4")		
5. Seat (2)	RPTFE		
6. End cap (2)	B16 (3/8")		
	B584-C84400 (1/2" to 4")		
7. Gland nut	B16		
8. Stem	B16 (except 3" & 4")		
9. Lever nut	Steel, zinc plated		

OPTIONS AVAILABLE:

(SUFFIX)	OPTION	SIZES
-02-	Static Grounded	3/8" to 4"
-03-	1-1/4" Stem Extension	3/8" to 2"
-04-	2-1/4" Stem Extension	3/8" to 2"
-05-	Plain Ball	3/8" to 4"
-07-	Tee Handle	3/8" to 2"
-08-	90° Reversed Stem	3/8" to 4"
-10-	SS Lever & Nut	3/8" to 4"
-14-	Vented Ball (see page J-2)	3/8" to 4"
-15-	Round Handle	3/8" to 2"
-16-	Vertical Chain Lever	1/2" to 2"
-18-	Plain Yellow Grip	3/8" to 2"
-19-	Lock Plate	3/8" to 4"
-20-	Slot Vented Ball	3/8" to 4"
-21-	UHMWPE Seats	3/8" to 4"
-23-	Tank Flange	2" ONLY
-24-	Graphite Stem Packing	3/8" to 4"
-27-	Latch Lock Lever	1/2" to 2"
-30-	CamLock Handle	3/8" to 1-1/4"
-32-	SS Tee Handle & Nut	3/8" to 2"
-35-	VTFE Trim	3/8" to 4"
-39-	SS Hi-Rise Locking Wheel Handle, SS Nut	3/8" to 1-1/4"
-40-	Cyl-Loc & Grounded	3/8" to 1/2"
-45-	Less Lever & Nut	3/8" to 4"
-46-	Latch-Lock Lever - Lock in Closed Position Only	1/2" to 2"
-47-	SS Oval Latch-Lock Handle & Nut	3/8" to 3/4"
-48-	SS Oval Handle (No Latch) & Nut	1/4" to 2"
-49-	Assembled Dry	3/8" to 4"
-50-	2-1/4" CS Locking Stem Extension	3/8" to 2"
-56-	Multifill Seats & Graphite Packing	3/8" to 4"
-57-	Oxygen Cleaned	3/8" to 4"
-58-	Chain Lever - Horizontal	1/2" to 2"
-59-	SS External Trim - 3-pc. Valves	3/8" to 4"
-60-	Grounded Ball & Stem	3/8" to 4"

VARIATIONS AVAILABLE:

82-240 Series (316 SS Ball & Stem)

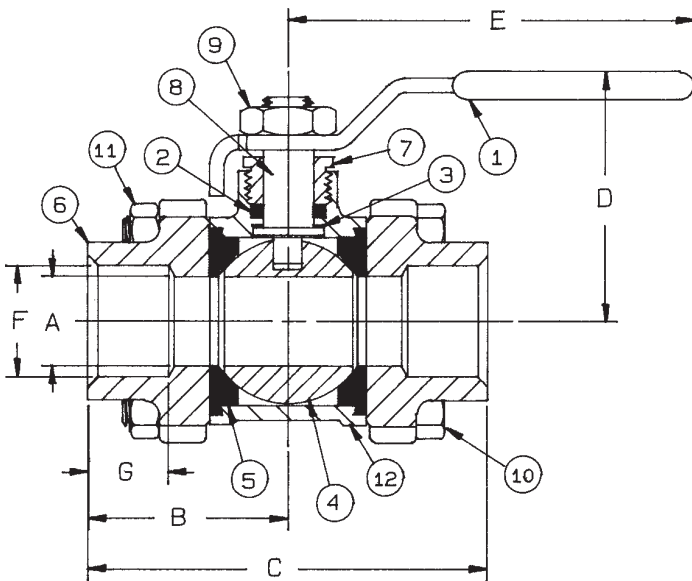

BRONZE 3-PIECE FULL PORT BALL VALVE

NUMBER	SIZE	A	B	C	D	E	F	G	Wt.
82-202-01	3/8"	.50	1.28	2.56	1.81	3.87	.505	.37	.99
82-203-01	1/2"	.62	1.40	2.81	1.93	4.87	.630	.50	1.46
82-204-01	3/4"	.81	1.71	3.43	2.18	4.87	.880	.75	2.07
82-205-01	1"	1.00	1.93	3.87	2.62	5.50	1.130	.90	3.03
82-206-01	1-1/4"	1.25	2.37	4.75	2.87	5.50	1.380	.96	5.02
82-207-01	1-1/2"	1.50	2.60	5.25	3.37	8.00	1.630	1.09	7.91
82-208-01	2"	2.00	3.01	6.03	3.68	8.00	2.130	1.34	13.50
82-209-01	2-1/2"	2.50	3.62	7.25	5.14	9.38	2.630	1.47	26.61
82-240-01	3"	3.00	4.00	8.00	6.77	18.00	3.130	1.66	42.24
82-24A-01	4"	4.00	5.50	11.00	8.26	18.00	4.130	2.16	88.40

**For Pressure/Temperature Ratings,
Refer to Page M-8, Graph No. 4**



83R-100 Series

Carbon Steel 3-Piece Full Port Ball Valve With Actuator Ready ISO Mounting Pad 1/4" through 2"

Full Port Threaded, 1/4" to 1" 1000 psig CWP, 1-1/4" to 2" 800 psig CWP, Cold Non-Shock. 150 psig Saturated Steam. Vacuum Service to 29 inches Hg.

Federal Specification: WW-V-35C, Type: II, Composition: CS, Style: 1.

MSS SP-110; Ball Valve Threaded, Socket-Welding, Solder Joint, Grooved and Flared Ends.

FEATURES

- Multi-piece packing set
- ISO 5211 mounting pad
- Blow-out-proof stem design
- In-line repairable
- Adjustable packing gland
- Investment cast components
- RPTFE seats and seals
- Full port configuration

STANDARD MATERIAL LIST

1. Stem	A108-CS	7. Hex nut (4)	Stl-gr. 8-zinc plt
2. Jam nut	Steel, zinc plate	8. Seat (2)	RPTFE
3. Low profile nut	316 SS	9. Ball	A108-CS chrome plate
4. Gland	A276-316	10. Body bolt (4)	Stl-gr. 8-zinc plt
5. Stem bearing	RPTFE	11. Stem packing	MPTFE
6. End cap (2)	A108-CS (1/4" to 1") A216-WCB (1-1/4" to 2")	12. Body	ASTM A216-WCB
		13. Lock tab washer	304 SS
		14. Lever and grip	Stl-zinc plt-w/vinyl

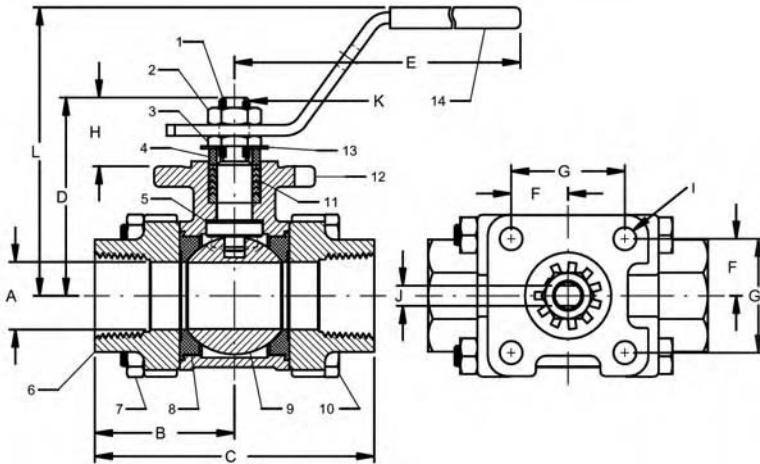

**For Pressure/Temperature Ratings,
Refer to Page M-10, Graph No. 7**

CARBON STEEL 3-PIECE FULL PORT
BALL VALVE WITH ISO MOUNTING PAD

VARIATIONS AVAILABLE:

- 83R-140 Series (316 SS Ball & Stem)
- Meets NACE MR-01-75 (1-1/4" to 2")

OPTIONS AVAILABLE:

(SUFFIX)	OPTION	SIZES
-02-	Static Grounded	1/4" to 2"
-03-	1-1/4" Stem Extension	1/4" to 2"
-04-	2-1/4" Stem Extension	1/4" to 2"
-08-	90° Reversed Stem	1/4" to 2"
-10-	SS Lever & Nut	1/4" to 3"
-14-	Vented Ball	1/4" to 2"
-18-	Plain Yellow Grip	1/4" to 2"
-21-	UHMWPE Seats (Non-PTFE)	1/4" to 2"
-24-	Graphite Stem Packing	1/4" to 2"
-27-	Latch Lock Lever	1/2" to 2"
-35-	VTFE Trim	1/4" to 2"
-36-	SS Round Handle	1/4" to 2"
-39-	SS Hi-Rise Locking Wheel Handle, SS Nut	1/4" to 2"
-56-	Multifill Seats & Graphite Packing	1/4" to 2"
-59-	SS External Trim - 3-pc. Valves	1/4" to 2"
-60-	Grounded Ball & Stem	1/4" to 2"
-63-	NPT x Socket Weld	1/4" to 2"
-66-	NPT x Butt weld	1/4" to 2"
-P01-	BSPP (Parallel) Thread Connection	1/4" to 2"
-T01-	BSPT (Tapered) Thread Connection	1/4" to 2"
-AR-	Less Handle & Stop-Add Belleville Washers	1/4" to 2"
-WB-	With Lever & Belleville Washers	1/4" to 2"

NUMBER	SIZE	A	B	C	D	E	F	G	H	I	J (FLATS)	K (THRDS.) UNF	L
83R-101-01	1/4"	.43	1.40	2.81	2.05	4.18	.59	1.17	.61	.28	.247/.249	3/8-24	3.28
83R-102-01	3/8"	.50	1.40	2.81	2.05	4.18	.59	1.17	.61	.28	.247/.249	3/8-24	3.28
83R-103-01	1/2"	.62	1.40	2.81	2.05	4.18	.59	1.17	.61	.28	.247/.249	3/8-24	3.28
83R-104-01	3/4"	.81	1.71	3.42	2.42	4.93	.70	1.39	.84	.28	.247/.249	3/8-24	3.52
83R-105-01	1"	1.00	1.92	3.85	2.54	4.93	.70	1.39	.84	.28	.247/.249	3/8-24	3.64
83R-106-01	1-1/4"	1.25	2.35	4.70	3.16	8.06	.98	1.95	1.16	.34	.370/.372	5/8-18	4.06
83R-107-01	1-1/2"	1.50	2.59	5.18	3.49	8.06	.98	1.95	1.16	.34	.370/.372	5/8-18	4.38
83R-108-01	2"	2.00	3.01	6.03	3.95	8.06	.98	1.95	1.16	.34	.370/.372	5/8-18	4.85



83R-100 Series

Carbon Steel 3-Piece Full Port Ball Valve With Actuator Ready ISO Mounting Pad 3"

Full Port Threaded, 800 psig CWP, Cold Non-Shock. 150 psig Saturated Steam.

Vacuum Service to 29 inches Hg.

Federal Specification: WW-V-35C, Type: II, Composition: CS, Style: 1.

MSS SP-110; Ball Valve Threaded, Socket-Welding, Solder Joint, Grooved and Flared Ends.

FEATURES

- Multi-piece packing set
- ISO 5211 mounting pad
- Blow-out-proof stem design
- In-line repairable
- Adjustable packing gland
- Investment cast components
- RPTFE seats and seals
- Full port configuration

STANDARD MATERIAL LIST

1. Body	ASTM A216-WCB	12. Stem Bearing	RPTFE
2. End Caps	ASTM A216-WCB	13. Stops (2)	SS
3. Ball	A108-CS, Chrome Plated	14. Stop Screws (2)	SS
4. Stem	A108-CS	15. Lock Plate	SS
5. Packing Gland	CS	16. Grounding Spring	SS
6. Stem Seal	MPTFE	17. Body Bolts (6)	SS
7. Seats (2)	RPTFE	18. Heavy Hex Nuts (6)	SS
8. Gland Screws (2)	SS	19. Body Seals (2)	RPTFE
9. Gland Plate	SS	20. Seat Holders (2)	CS
10. Adapter Screw	SS	21. Pipe Handle	(not shown)
11. Handle Adapter	SS		

VARIATIONS AVAILABLE:

- 83R-140 Series (316 SS Ball & Stem)
- Meets NACE MR-01-75

OPTIONS AVAILABLE:

(SUFFIX)	OPTION
-02-	Static Grounded
-14-	Vented Ball
-24-	Graphite Stem Packing
-35-	VTFE Trim
-49-	Assembled Dry
-57-	Cleaned For Gaseous Oxygen
-60-	Grounded Ball & Stem
-63-	NPT x Socket Weld

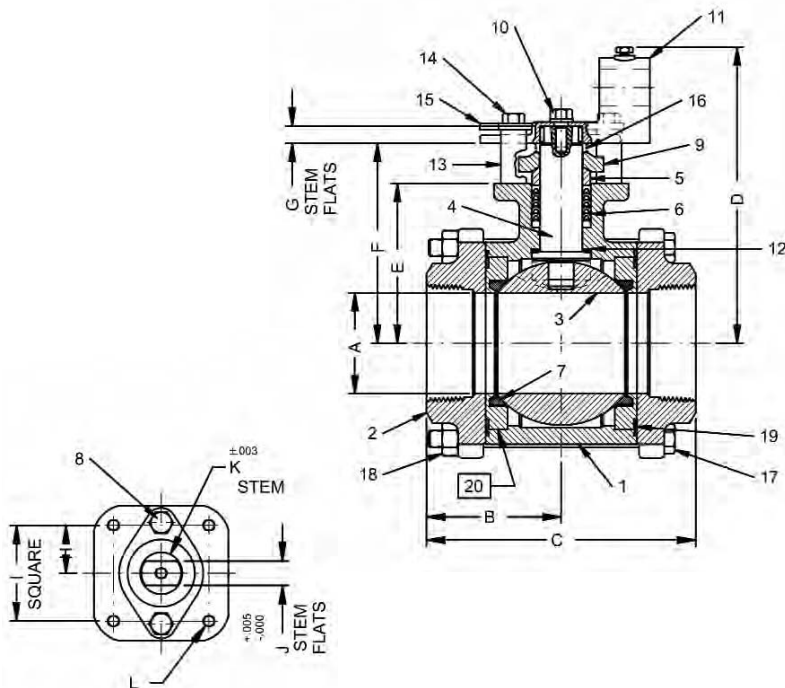

**For Pressure/Temperature Ratings,
Refer to Page M-10, Graph No. 7**

CARBON STEEL 3-PIECE FULL PORT
BALL VALVE WITH ISO MOUNTING PAD

NUMBER	SIZE	A	B	C	D	E	F	G	H	I	J (FLATS)	K	L (THRDS.) UNF
83R-101-01	3"	3.00	4.00	8.00	8.80	4.75	5.94	.50	1.420	2.480	.725	1.250	3.28



83R-200 Series

Carbon Steel 3-Piece Full Port Socket Weld Ball Valve With Actuator Ready ISO Mounting Pad 1/2" through 2"

Socket Weld, 1/2" to 1" 1000 psig CWP, 1-1/4" to 2" 800 psig CWP, Cold Non-Shock. 150 psig Saturated Steam. Vacuum Service to 29 inches Hg.

Federal Specification: WW-V-35C, Type: II, Composition: CS, Style: 1.

MSS SP-110; Ball Valve Threaded, Socket-Welding, Solder Joint, Grooved and Flared Ends.

FEATURES

- Multi-piece packing set
- ISO 5211 mounting pad
- Blow-out-proof stem design
- In-line repairable
- Adjustable packing gland
- Investment cast components
- RPTFE seats and seals
- Full port configuration

STANDARD MATERIAL LIST

1. Stem	A108-CS	7. Hex nut (4)	Stl-gr. 8-zinc plt
2. Jam nut	Steel, zinc plate	8. Seat (2)	RPTFE
3. Low profile nut	316 SS	9. Ball	A108-CS chrome plate
4. Gland	A276-316	10. Body bolt (4)	Stl-gr. 8-zinc plt
5. Stem bearing	RPTFE	11. Stem packing	MPTFE
6. End cap (2)	A108-CS (1/2" to 1") A216-WCB (1-1/4" to 2")	12. Body	ASTM A216-WCB
		13. Lock tab washer	304 SS
		14. Lever and grip	Stl-zinc plt-w/vinyl

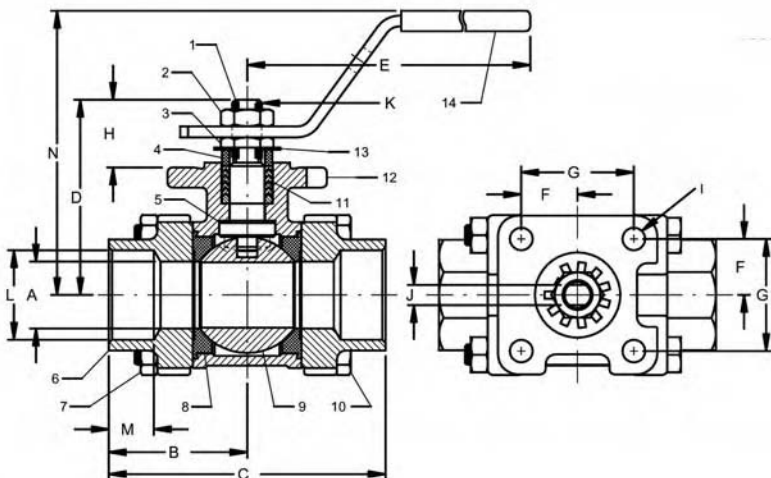

**For Pressure/Temperature Ratings,
Refer to Page M-10, Graph No. 7**

VARIATIONS AVAILABLE:

- 83R-240 Series (316 SS Ball & Stem)
- Meets NACE MR-01-75 (1-1/4" to 2")

OPTIONS AVAILABLE:

(SUFFIX)	OPTION	SIZES
-02-	Static Grounded	1/2" to 2"
-03-	1-1/4" Stem Extension	1/2" to 2"
-04-	2-1/4" Stem Extension	1/2" to 2"
-08-	90° Reversed Stem	1/2" to 2"
-10-	SS Lever & Nut	1/2" to 2"
-14-	Vented Ball	1/2" to 2"
-18-	Plain Yellow Grip	1/2" to 2"
-21-	UHMWPE Seats (Non-PTFE)	1/2" to 2"
-24-	Graphite Stem Packing	1/2" to 2"
-27-	Latch Lock Lever	1/2" to 2"
-35-	VTFE Trim	1/2" to 2"
-36-	SS Round Handle	1/2" to 2"
-39-	SS Hi-Rise Locking Wheel Handle, SS Nut	1/2" to 2"
-59-	SS External Trim - 3-pc. Valves	1/2" to 2"
-60-	Grounded Ball & Stem	1/2" to 2"
-AR-	Less Handle & Stop-Add Belleville Washers	1/2" to 2"
-WB-	With Lever & Belleville Washers	1/2" to 2"

CARBON STEEL 3-PIECE FULL PORT SOCKET WELD BALL VALVE WITH ISO MOUNTING PAD

NUMBER	SIZE	A	B	C	D	E	F	G	H	I	J (FLATS)	K (THRDS.) UNF	L	M	N
83R-203-01	1/2"	.62	1.40	2.81	2.05	4.18	.59	1.17	.61	.28	.247/.249	3/8-24	.855	.43	3.28
83R-204-01	3/4"	.81	1.71	3.42	2.42	4.93	.70	1.39	.84	.28	.247/.249	3/8-24	1.065	.56	3.52
83R-205-01	1"	1.00	1.92	3.85	2.54	4.93	.70	1.39	.84	.28	.247/.249	3/8-24	1.330	.68	3.64
83R-206-01	1-1/4"	1.25	2.35	4.70	3.16	8.06	.98	1.95	1.16	.34	.370/.372	5/8-18	1.675	.81	4.06
83R-207-01	1-1/2"	1.50	2.59	5.18	3.49	8.06	.98	1.95	1.16	.34	.370/.372	5/8-18	1.915	.87	4.38
83R-208-01	2"	2.00	3.01	6.03	3.95	8.06	.98	1.95	1.16	.34	.370/.372	5/8-18	2.405	1.05	4.85



83R-200 Series

Carbon Steel 3-Piece Full Port Socket Weld Ball Valve With Actuator Ready ISO Mounting Pad 3"

Socket Weld, 800 psig CWP, Cold Non-Shock. 150 psig Saturated Steam.

Vacuum Service to 29 inches Hg.

Federal Specification: WW-V-35C, Type: II, Composition: CS, Style: 1.

MSS SP-110; Ball Valve Threaded, Socket-Welding, Solder Joint, Grooved and Flared Ends.

FEATURES

- Multi-piece packing set
- ISO 5211 mounting pad
- Blow-out-proof stem design
- In-line repairable
- Adjustable packing gland
- Investment cast components
- RPTFE seats and seals
- Full port configuration

STANDARD MATERIAL LIST

1. Body	ASTM A216-WCB	12. Stem Bearing	RPTFE
2. End Caps	ASTM A216-WCB	13. Stops (2)	SS
3. Ball	A108-CS, Chrome Plated	14. Stop Screws (2)	SS
4. Stem	A108-CS	15. Lock Plate	SS
5. Packing Gland	CS	16. Grounding Spring	SS
6. Stem Seal	MPTFE	17. Body Bolts (6)	SS
7. Seats (2)	RPTFE	18. Heavy Hex Nuts (6)	SS
8. Gland Screws (2)	SS	19. Body Seals (2)	RPTFE
9. Gland Plate	SS	20. Seat Holders (2)	CS
10. Adapter Screw	SS	21. Pipe Handle	(not shown)
11. Handle Adapter	SS		

VARIATIONS AVAILABLE:

- 83R-240 Series (316 SS Ball & Stem)
- Meets NACE MR-01-75

OPTIONS AVAILABLE:

(SUFFIX)	OPTION
-02-	Static Grounded
-14-	Vented Ball
-24-	Graphite Stem Packing
-35-	VTFE Trim
-49-	Assembled Dry
-57-	Cleaned For Gaseous Oxygen
-60-	Grounded Ball & Stem

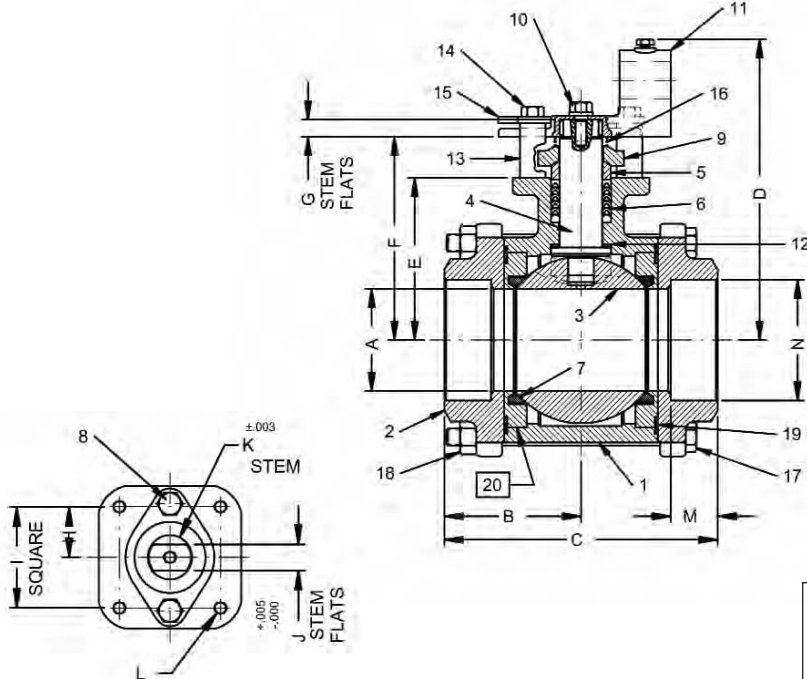

**For Pressure/Temperature Ratings,
Refer to Page M-10, Graph No. 7**

CARBON STEEL 3-PIECE FULL PORT SOCKET WELD BALL VALVE WITH ISO MOUNTING PAD

NUMBER	SIZE	A	B	C	D	E	F	G	H	I	J (FLATS)	K	L (THRDS.) UNF	M	N
83R-200-01	3"	3.00	4.00	8.00	8.80	4.75	5.94	.50	1.420	2.480	.725	1.250	3/8-16	1.37	3.54



83R-700 Series

Carbon Steel 3-Piece Full Port Butt-Weld Ball Valve With Actuator Ready ISO Mounting Pad

Schedule 40 Butt-Weld Ends, 1/2" to 1" 1000 psig WOG, 1-1/2" & 2" 800 psig WOG, Cold Non-Shock. 150 psig Saturated Steam.

Vacuum Service to 29 inches Hg.

Federal Specification: WW-V-35C, Type: II, Composition: CS, Style: 1.

MSS SP-72; Ball Valves with Flanged or Butt-Weld Ends for General Service.

FEATURES

- Multi-piece packing set
- ISO 5211 mounting pad
- Blow-out-proof stem design
- In-line repairable
- Adjustable packing gland
- Investment cast components
- RPTFE seats and seals
- Full port configuration

STANDARD MATERIAL LIST

1. Stem	A108-CS	7. Hex nut (4)	Stl-gr. 8-zinc plt
2. Jam nut	Steel, zinc plate	8. Seat (2)	RPTFE
3. Low profile nut	316 SS	9. Ball	A108-CS chrome plate
4. Gland	A276-316	10. Body bolt (4)	Stl-gr. 8-zinc plt
5. Stem bearing	RPTFE	11. Stem packing	MPTFE
6. End cap (2)	A108-CS (1/2" to 1")	12. Body	ASTM A216-WCB
	A216-WCB (1-1/4" to 2")	13. Lock tab washer	304 SS
		14. Lever and grip	Stl-zinc plt-w/vinyl

VARIATIONS AVAILABLE:

- 83R-740 Series (316 SS Ball & Stem)
- Meets NACE MR-01-75 (1-1/4" to 2")

OPTIONS AVAILABLE:

(SUFFIX)	OPTION	SIZES
-02-	Static Grounded	1/2" to 2"
-03-	1-1/4" Stem Extension	1/2" to 2"
-04-	2-1/4" Stem Extension	1/2" to 2"
-08-	90° Reversed Stem	1/2" to 2"
-10-	SS Lever & Nut	1/2" to 2"
-14-	Vented Ball	1/2" to 2"
-18-	Plain Yellow Grip	1/2" to 2"
-21-	UHMWPE Seats (Non-PTFE)	1/2" to 2"
-24-	Graphite Stem Packing	1/2" to 2"
-27-	Latch Lock Lever	1/2" to 2"
-35-	VTFE Trim	1/2" to 2"
-36-	SS Round Handle	1/2" to 2"
-39-	SS Hi-Rise Locking Wheel Handle, SS Nut	1/2" to 2"
-59-	SS External Trim - 3-pc. Valves	1/2" to 2"
-60-	Grounded Ball & Stem	1/2" to 2"
-AR-	Less Handle & Stop-Add Belleville Washers	1/2" to 2"
-WB-	With Lever & Belleville Washers	1/2" to 2"

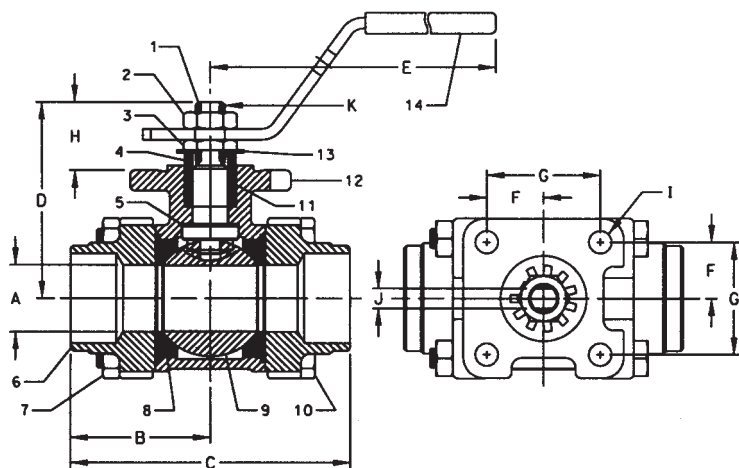

**For Pressure/Temperature Ratings,
Refer to Page M-10, Graph No. 7**

CARBON STEEL 3-PIECE FULL PORT BUTT-WELD BALL VALVE WITH ISO MOUNTING PAD

NUMBER	SIZE	A	B	C	D	E	F	G	H	I	J (FLATS)	K (THRDS.) UNF
83R-703-01	1/2"	.62	1.40	2.81	2.05	4.18	.59	1.17	.61	.28	.247/.249	3/8-24
83R-704-01	3/4"	.81	1.71	3.42	2.42	4.93	.70	1.39	.84	.28	.247/.249	3/8-24
83R-705-01	1"	1.00	1.98	3.97	2.54	4.93	.70	1.39	.84	.28	.247/.249	3/8-24
83R-707-01	1-1/2"	1.50	2.59	5.18	3.49	8.06	.98	1.95	1.16	.34	.370/.372	5/8-18
83R-708-01	2"	2.00	3.01	6.03	3.95	8.06	.98	1.95	1.16	.34	.370/.372	5/8-18



85R-100 Series

Stainless Steel 3-Piece Ball Valve With Actuator Ready ISO Mounting Pad

Std. Port Threaded, 3/4" to 1-1/4" 1000 psig WOG, 1-1/2" & 2" 800 psig WOG, Cold Non-Shock. 150 psig Saturated Steam. Vacuum Service to 29 inches Hg.

Federal Specification: WW-V-35C, Type: II, Composition: SS, Style: 1.

MSS SP-110; Ball Valve Threaded, Socket-Welding, Solder Joint, Grooved and Flared Ends.

FEATURES

- Multi-piece packing set
- ISO 5211 mounting pad
- Blow-out-proof stem design
- In-line repairable
- Adjustable packing gland
- Investment cast components
- RPTFE seats and seals
- Full port configuration
- Meets NACE MR01-75

STANDARD MATERIAL LIST

1. Stem	A276-316	8. Seat (2)	RPTFE
2. Jam nut	SS	9. Ball	316 SS
3. Low profile nut	316 SS	10. Body bolt (4)	18-8 SS
4. Gland	A276-316	11. Stem packing	MPTFE
5. Stem bearing	RPTFE	12. Body	ASTM A351-CF8M
6. End cap (2)	ASTM A351-CF3M	13. Lock tab washer	304 SS
7. Hex nut (4)	18-8 SS	14. Lever and grip	304 SS w/vinyl

OPTIONS AVAILABLE:

(SUFFIX)	OPTION	SIZES
-02-	Static Grounded	3/4" to 2"
-03-	1-1/4" Stem Extension	3/4" to 2"
-04-	2-1/4" Stem Extension	3/4" to 2"
-08-	90° Reversed Stem	3/4" to 2"
-14-	Vented Ball	3/4" to 2"
-18-	Plain Yellow Grip	3/4" to 2"
-21-	UHMWPE Seats (Non-PTFE)	3/4" to 2"
-24-	Graphite Stem Packing	3/4" to 2"
-27-	Latch Lock Lever	3/4" to 2"
-35-	VTFE Trim	3/4" to 2"
-36-	SS Round Handle	3/4" to 2"
-39-	SS Hi-Rise Locking Wheel Handle, SS Nut	3/4" to 2"
-49-	Assembled Dry	3/4" to 2"
-57-	Oxygen Cleaned	3/4" to 2"
-60-	Grounded Ball & Stem	3/4" to 2"
-63-	Threaded x Socket Weld	3/4" to 2"
-P01-	BSPP (Parallel) Thread Connection	3/4" to 2"
-T01-	BSPT (Tapered) Thread Connection	3/4" to 2"
-AR-	Less Handle & Stop-Add Belleville Washers	3/4" to 2"
-WB-	With Lever & Belleville Washers	3/4" to 2"

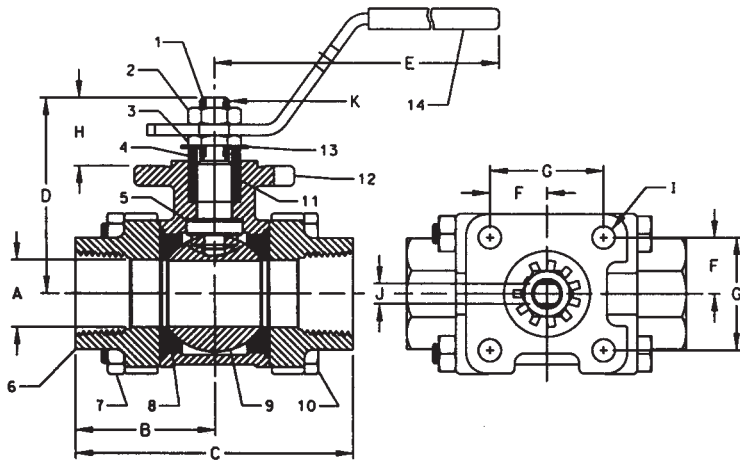

**For Pressure/Temperature Ratings,
Refer to Page M-10, Graph No. 8**

STAINLESS STEEL 3-PIECE STANDARD PORT BALL VALVE WITH ISO MOUNTING PAD

NUMBER	SIZE	A	B	C	D	E	F	G	H	I	J (FLATS)	K (THRDS.) UNF
85R-104-01	3/4"	.62	1.40	2.81	2.05	4.18	.59	1.17	.61	.28	.247/.249	3/8-24
85R-105-01	1"	.81	1.71	3.42	2.42	4.93	.70	1.39	.84	.28	.247/.249	3/8-24
85R-106-01	1-1/4"	1.00	1.92	3.85	2.54	4.93	.70	1.39	.84	.28	.247/.249	3/8-24
85R-107-01	1-1/2"	1.25	2.35	4.70	3.16	8.06	.98	1.95	1.16	.34	.370/.372	5/8-18
85R-108-01	2"	1.50	2.59	5.18	3.49	8.06	.98	1.95	1.16	.34	.370/.372	5/8-18



85R-200 Series

Stainless Steel 3-Piece Standard Port Socket Weld Ball Valve With Actuator Ready ISO Mounting Pad

Socket Weld, 3/4" to 1-1/4" 1000 psig WOG, 1-1/2" & 2" 800 psig WOG, Cold Non-Shock. 150 psig Saturated Steam. Vacuum Service to 29 inches Hg.

Federal Specification: WW-V-35C, Type: II, Composition: SS, Style: 1.

MSS SP-110; Ball Valve Threaded, Socket-Welding, Solder Joint, Grooved and Flared Ends.

FEATURES

- Multi-piece packing set
- ISO 5211 mounting pad
- Blow-out-proof stem design
- In-line repairable
- Adjustable packing gland
- Investment cast components
- RPTFE seats and seals
- Standard port configuration
- Meets NACE MR01-75

STANDARD MATERIAL LIST

1. Stem	A276-316	8. Seat (2)	RPTFE
2. Jam nut	SS	9. Ball	316 SS
3. Low profile nut	316 SS	10. Body bolt (4)	18-8 SS
4. Gland	A276-316	11. Stem packing	MPTFE
5. Stem bearing	RPTFE	12. Body	ASTM A351-CF8M
6. End cap (2)	ASTM A351-CF3M	13. Lock tab washer	304 SS
7. Hex nut (4)	18-8 SS	14. Lever and grip	304 SS w/vinyl

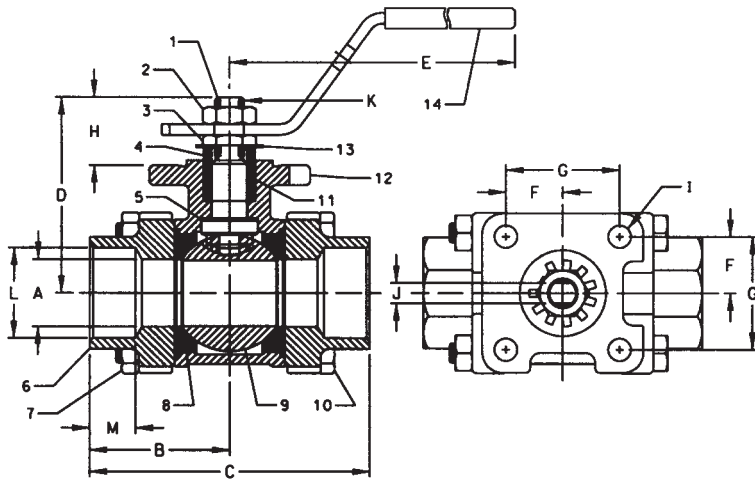

OPTIONS AVAILABLE:

(SUFFIX)	OPTION	SIZES
-02-	Static Grounded	3/4" to 2"
-03-	1-1/4" Stem Extension	3/4" to 2"
-04-	2-1/4" Stem Extension	3/4" to 2"
-08-	90° Reversed Stem	3/4" to 2"
-14-	Vented Ball	3/4" to 2"
-18-	Plain Yellow Grip	3/4" to 2"
-21-	UHMWPE Seats (Non-PTFE)	3/4" to 2"
-24-	Graphite Stem Packing	3/4" to 2"
-27-	Latch Lock Lever	3/4" to 2"
-35-	VTFE Trim	3/4" to 2"
-36-	SS Round Handle	3/4" to 2"
-39-	SS Hi-Rise Locking Wheel Handle, SS Nut	3/4" to 2"
-49-	Assembled Dry	3/4" to 2"
-57-	Oxygen Cleaned	3/4" to 2"
-60-	Grounded Ball & Stem	3/4" to 2"
-AR-	Less Handle & Stop-Add Belleville Washers	3/4" to 2"
-WB-	With Lever & Belleville Washers	3/4" to 2"

**For Pressure/Temperature Ratings,
Refer to Page M-10, Graph No. 8**

STAINLESS STEEL 3-PIECE STANDARD PORT SOCKET WELD BALL VALVE WITH ISO MOUNTING PAD

NUMBER	SIZE	A	B	C	D	E	F	G	H	I	J (FLATS)	K (THRDS.) UNF	L	M
85R-204-01	3/4"	.62	1.40	2.81	2.05	4.18	.59	1.17	.61	.28	.247/.249	3/8-24	1.065	.56
85R-205-01	1"	.81	1.71	3.42	2.42	4.93	.70	1.39	.84	.28	.247/.249	3/8-24	1.330	.68
85R-206-01	1-1/4"	1.00	1.92	3.85	2.54	4.93	.70	1.39	.84	.28	.247/.249	3/8-24	1.675	.81
85R-207-01	1-1/2"	1.25	2.35	4.70	3.16	8.06	.98	1.95	1.16	.34	.370/.372	5/8-18	1.915	.87
85R-208-01	2"	1.50	2.59	5.18	3.49	8.06	.98	1.95	1.16	.34	.370/.372	5/8-18	2.406	1.06



86R-100 Series

Stainless Steel 3-Piece Full Port Ball Valve With Actuator Ready ISO Mounting Pad 1/4" through 2"

Full Port Threaded, 1/4" to 1" 1000 psig CWP, 1-1/4" to 2" 800 psig CWP, Cold Non-Shock. 150 psig Saturated Steam. Vacuum Service to 29 inches Hg.
Federal Specification: WW-V-35C, Type: II, Composition: SS, Style: 1.
MSS SP-110; Ball Valve Threaded, Socket-Welding, Solder Joint, Grooved and Flared Ends.

FEATURES

- Multi-piece packing set
- ISO 5211 mounting pad
- Blow-out-proof stem design
- In-line repairable
- Adjustable packing gland
- Investment cast components
- RPTFE seats and seals
- Full port configuration
- Meets NACE MR01-75

STANDARD MATERIAL LIST

1. Stem	A276-316	8. Seat (2)	RPTFE
2. Jam nut	SS	9. Ball	316 SS
3. Low profile nut	316 SS	10. Body bolt (4)	18-8 SS
4. Gland	A276-316	11. Stem packing	MPTFE
5. Stem bearing	RPTFE	12. Body	ASTM A351-CF8M
6. End cap (2)	ASTM A351-CF3M	13. Lock tab washer	304 SS
7. Hex nut (4)	18-8 SS	14. Lever and grip	304 SS w/vinyl

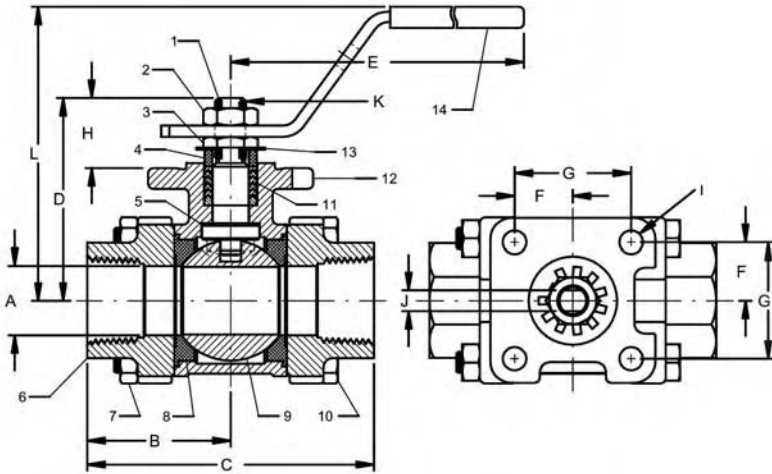

OPTIONS AVAILABLE:

(SUFFIX)	OPTION	SIZES
-02-	Static Grounded	1/4" to 2"
-03-	1-1/4" Stem Extension	1/4" to 2"
-04-	2-1/4" Stem Extension	1/4" to 2"
-08-	90° Reversed Stem	1/4" to 2"
-14-	Vented Ball	1/4" to 2"
-18-	Plain Yellow Grip	1/4" to 2"
-21-	UHMWPE Seats (Non-PTFE)	1/4" to 2"
-24-	Graphite Stem Packing	1/4" to 2"
-27-	Latch Lock Lever	1/4" to 2"
-35-	VTFE Trim	1/4" to 2"
-36-	SS Round Handle	1/4" to 2"
-39-	SS Hi-Rise Locking Wheel Handle, SS Nut	1/4" to 2"
-49-	Assembled Dry	1/4" to 2"
-57-	Oxygen Cleaned	1/4" to 2"
-60-	Grounded Ball & Stem	1/4" to 2"
-63-	Threaded x Socket Weld	1/4" to 2"
-P01-	BSPP (Parallel) Thread Connection	1/4" to 2"
-T01-	BSPT (Tapered) Thread Connection	1/4" to 2"
-AR-	Less Handle & Stop-Add Belleville Washers	1/4" to 2"
-WB-	With Lever & Belleville Washers	1/4" to 2"

**For Pressure/Temperature Ratings,
Refer to Page M-10, Graph No. 8**

STAINLESS STEEL 3-PIECE FULL PORT BALL VALVE WITH ISO MOUNTING PAD

NUMBER	SIZE	A	B	C	D	E	F	G	H	I	J (FLATS)	K (THRDS.) UNF	L
86R-101-01	1/4"	.43	1.40	2.81	2.05	4.18	.59	1.17	.61	.28	.247/.249	3/8-24	3.28
86R-102-01	3/8"	.50	1.40	2.81	2.05	4.18	.59	1.17	.61	.28	.247/.249	3/8-24	3.28
86R-103-01	1/2"	.62	1.40	2.81	2.05	4.18	.59	1.17	.61	.28	.247/.249	3/8-24	3.28
86R-104-01	3/4"	.81	1.71	3.42	2.42	4.93	.70	1.39	.84	.28	.247/.249	3/8-24	3.52
86R-105-01	1"	1.00	1.92	3.85	2.54	4.93	.70	1.39	.84	.28	.247/.249	3/8-24	3.64
86R-106-01	1-1/4"	1.25	2.35	4.70	3.16	8.06	.98	1.95	1.16	.34	.370/.372	5/8-18	4.06
86R-107-01	1-1/2"	1.50	2.59	5.18	3.49	8.06	.98	1.95	1.16	.34	.370/.372	5/8-18	4.38
86R-108-01	2"	2.00	3.01	6.03	3.95	8.06	.98	1.95	1.16	.34	.370/.372	5/8-18	4.85



86R-100 Series

Stainless Steel 3-Piece Full Port Ball Valve With Actuator Ready ISO Mounting Pad 3"

Full Port Threaded, 800 psig CWP, Cold Non-Shock. 150 psig Saturated Steam.
Vacuum Service to 29 inches Hg.

Federal Specification: WW-V-35C, Type: II, Composition: SS, Style: 1.

MSS SP-110; Ball Valve Threaded, Socket-Welding, Solder Joint, Grooved and Flared Ends.

FEATURES

- Multi-piece packing set
- ISO 5211 mounting pad
- Blow-out-proof stem design
- In-line repairable
- Adjustable packing gland
- Investment cast components
- RPTFE seats and seals
- Full port configuration
- Meets NACE MR01-75

STANDARD MATERIAL LIST

1. Body	ASTM A351-CF8M	12. Stem Bearing	RPTFE
2. End Caps (2)	ASTM A351-CF8M	13. Stops (2)	SS
3. Ball	316 SS	14. Stop Screws (2)	SS
4. Stem	A276-316	15. Lock Plate	SS
5. Packing Gland	316 SS	16. Grounding Spring	SS
6. Stem Seal	MPTFE	17. Body Bolts (6)	SS
7. Seats (2)	RPTFE	18. Heavy Hex Nuts (6)	SS
8. Gland Screws (2)	SS	19. Body Seals (2)	RPTFE
9. Gland Plate	SS	20. Seat Holders (2)	SS
10. Adapter Screw	SS	21. Pipe Handle	(not shown)
11. Handle Adapter	SS		

OPTIONS AVAILABLE:

(SUFFIX)	OPTION
-02-	Static Grounded
-14-	Vented Ball
-24-	Graphite Stem Packing
-35-	VTFE Trim
-49-	Assembled Dry
-57-	Oxygen Cleaned
-60-	Grounded Ball & Stem
-63-	Threaded x Socket Weld

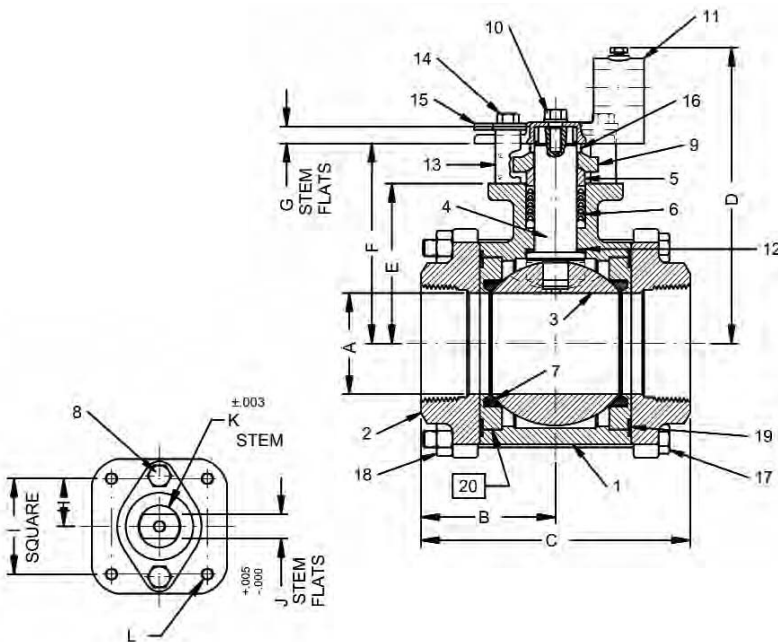

**For Pressure/Temperature Ratings,
Refer to Page M-10, Graph No. 8**

STAINLESS STEEL 3-PIECE FULL PORT
BALL VALVE WITH ISO MOUNTING PAD

NUMBER	SIZE	A	B	C	D	E	F	G	H	I	J (FLATS)	K	L (THRDS.) UNF
86R-100-01	3"	3.00	4.00	8.00	8.80	4.75	5.94	.50	1.420	2.480	.725	1.250	3/8-16



86R-200 Series

Stainless Steel 3-Piece Full Port Socket Weld Valve Ball Valve With Actuator Ready ISO Mounting Pad 1/4" through 2"

Socket Weld, 1/4" to 1" 1000 psig CWP, 1-1/4" & 2" 800 psig CWP, Cold Non-Shock. 150 psig Saturated Steam. Vacuum Service to 29 inches Hg.
Federal Specification: WW-V-35C, Type: II, Composition: SS, Style: 1.
MSS SP-110; Ball Valve Threaded, Socket-Welding, Solder Joint, Grooved and Flared Ends.

FEATURES

- Multi-piece packing set
- ISO 5211 mounting pad
- Blow-out-proof stem design
- In-line repairable
- Adjustable packing gland
- Investment cast components
- RPTFE seats and seals
- Full port configuration
- Meets NACE MR01-75

STANDARD MATERIAL LIST

1. Stem	A276-316	8. Seat (2)	RPTFE
2. Jam nut	SS	9. Ball	316 SS
3. Low profile nut	316 SS	10. Body bolt (4)	18-8 SS
4. Gland	A276-316	11. Stem packing	MPTFE
5. Stem bearing	RPTFE	12. Body	ASTM A351-CF8M
6. End cap (2)	ASTM A351-CF3M	13. Lock tab washer	304 SS
7. Hex nut (4)	18-8 SS	14. Lever and grip	304 SS w/vinyl

OPTIONS AVAILABLE:

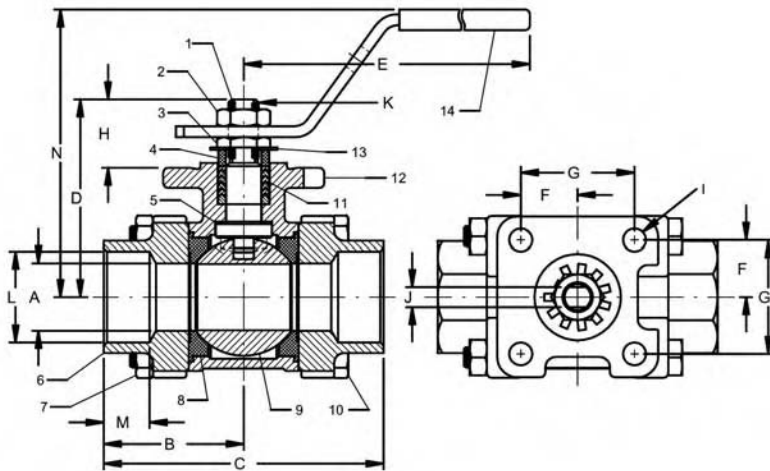

(SUFFIX)	OPTION	SIZES
-02	Static Grounded	1/4" to 2"
-03	1-1/4" Stem Extension	1/4" to 2"
-04	2-1/4" Stem Extension	1/4" to 2"
-08	90° Reversed Stem	1/4" to 2"
-14	Vented Ball	1/4" to 2"
-18	Plain Yellow Grip	1/4" to 2"
-21	UHMWPE Seats (Non-PTFE)	1/4" to 2"
-24	Graphite Stem Packing	1/4" to 2"
-27	Latch Lock Lever	1/4" to 2"
-35	VTFE Trim	1/4" to 2"
-36	SS Round Handle	3/4" to 2"
-39	SS Hi-Rise Locking Wheel Handle, SS Nut	1/4" to 2"
-49	Assembled Dry	1/4" to 2"
-56	Multi-fill Seats	1/4" to 2"
-57	Oxygen Cleaned	1/4" to 2"
-60	Grounded Ball & Stem	1/4" to 2"
-AR	Less Handle & Stop-Add Belleville Washers	1/4" to 2"
-WB	With Lever & Belleville Washers	1/4" to 2"

**For Pressure/Temperature Ratings,
Refer to Page M-10, Graph No. 8**

STAINLESS STEEL 3-PIECE FULL PORT SOCKET WELD BALL VALVE WITH ISO MOUNTING PAD

NUMBER	SIZE	A	B	C	D	E	F	G	H	I	J (FLATS)	K (THRDS.) UNF	L	M	N
86R-201-01	1/4"	.43	1.40	2.81	2.05	4.18	.59	1.17	.61	.28	.247/.249	3/8-24	.565	.50	3.28
86R-202-01	3/8"	.50	1.40	2.81	2.05	4.18	.59	1.17	.61	.28	.247/.249	3/8-24	.700	.56	3.28
86R-203-01	1/2"	.62	1.40	2.81	2.05	4.18	.59	1.17	.61	.28	.247/.249	3/8-24	.855	.43	3.28
86R-204-01	3/4"	.81	1.71	3.42	2.42	4.93	.70	1.39	.84	.28	.247/.249	3/8-24	1.065	.56	3.52
86R-205-01	1"	1.00	1.92	3.85	2.54	4.93	.70	1.39	.84	.28	.247/.249	3/8-24	1.330	.68	3.64
86R-206-01	1-1/4"	1.25	2.35	4.70	3.16	8.06	.98	1.95	1.16	.34	.370/.372	5/8-18	1.675	.81	4.06
86R-207-01	1-1/2"	1.50	2.59	5.18	3.49	8.06	.98	1.95	1.16	.34	.370/.372	5/8-18	1.915	.87	4.38
86R-208-01	2"	2.00	3.01	6.03	3.95	8.06	.98	1.95	1.16	.34	.370/.372	5/8-18	2.405	1.05	4.85



86R-200 Series

Stainless Steel 3-Piece Full Port Socket Weld Valve Ball Valve With Actuator Ready ISO Mounting Pad 3"

Socket Weld, 800 psig CWP, Cold Non-Shock. 150 psig Saturated Steam.
Vacuum Service to 29 inches Hg.

Federal Specification: WW-V-35C, Type: II, Composition: SS, Style: 1.

MSS SP-110; Ball Valve Threaded, Socket-Welding, Solder Joint, Grooved and Flared Ends.

FEATURES

- Multi-piece packing set
- ISO 5211 mounting pad
- Blow-out-proof stem design
- In-line repairable
- Adjustable packing gland
- Investment cast components
- RPTFE seats and seals
- Full port configuration
- Meets NACE MR01-75

STANDARD MATERIAL LIST

1. Body	ASTM A351-CF8M	12. Stem Bearing	RPTFE
2. End Caps (2)	ASTM A351-CF8M	13. Stops (2)	SS
3. Ball	316 SS	14. Stop Screws (2)	SS
4. Stem	A276-316	15. Lock Plate	SS
5. Packing Gland	316 SS	16. Grounding Spring	SS
6. Stem Seal	MPTFE	17. Body Bolts (6)	SS
7. Seats (2)	RPTFE	18. Heavy Hex Nuts (6)	SS
8. Gland Screws (2)	SS	19. Body Seals (2)	RPTFE
9. Gland Plate	SS	20. Seat Holders (2)	SS
10. Adapter Screw	SS	21. Pipe Handle	(not shown)
11. Handle Adapter	SS		

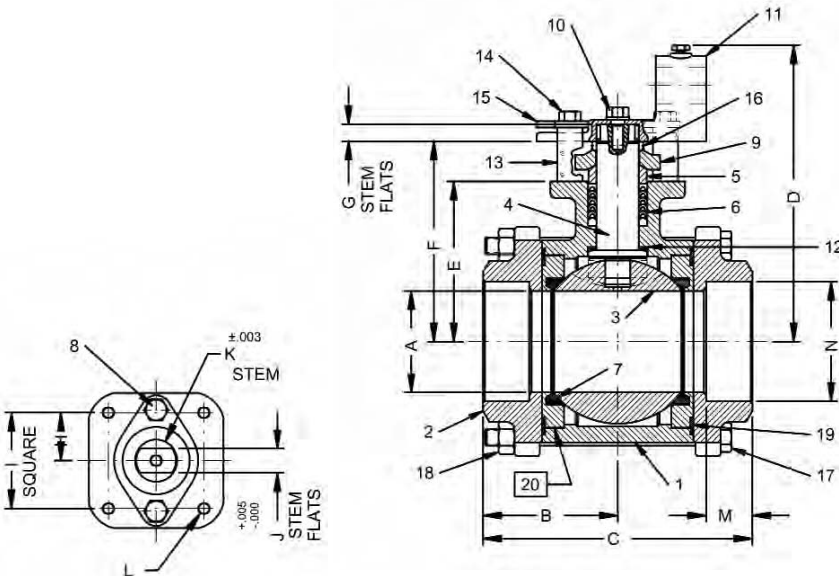

OPTIONS AVAILABLE:

(SUFFIX)	OPTION
-02-	Static Grounded
-14-	Vented Ball
-24-	Graphite Stem Packing
-35-	VTFE Trim
-49-	Assembled Dry
-57-	Oxygen Cleaned
-60-	Grounded Ball & Stem

**For Pressure/Temperature Ratings,
Refer to Page M-10, Graph No. 8**

STAINLESS STEEL 3-PIECE FULL PORT SOCKET WELD BALL VALVE WITH ISO MOUNTING PAD

NUMBER	SIZE	A	B	C	D	E	F	G	H	I	J (FLATS)	K	L (THRDS.) UNF	M	N
86R-200-01	3"	3.00	4.00	8.00	8.80	4.75	5.94	.50	1.420	2.480	.725	1.250	3/8-16	1.37	3.54



86R-700 Series

Stainless Steel 3-Piece Full Port Butt-Weld Ball Valve With Actuator Ready ISO Mounting Pad

Schedule 10 Butt-Weld Ends, 1/2" to 1" 1000 psig WOG, 1-1/2" & 2" 800 psig WOG, Cold Non-Shock. 150 psig Saturated Steam.

Vacuum Service to 29 inches Hg.

Federal Specification: WW-V-35C, Type: II, Composition: SS, Style: 1.

MSS SP-72; Ball Valves with Flanged or Butt-Weld Ends for General Service.

FEATURES

- Multi-piece packing set
- ISO 5211 mounting pad
- Blow-out-proof stem design
- In-line repairable
- Adjustable packing gland
- Investment cast components
- RPTFE seats and seals
- Full port configuration
- Meets NACE MR01-75

STANDARD MATERIAL LIST

1. Stem	A276-316	8. Seat (2)	RPTFE
2. Jam nut	SS	9. Ball	316 SS
3. Low profile nut	316 SS	10. Body bolt (4)	18-8 SS
4. Gland	A276-316	11. Stem packing	MPTFE
5. Stem bearing	RPTFE	12. Body	ASTM A351-CF8M
6. End cap (2)	ASTM A351-CF3M	13. Lock tab washer	304 SS
7. Hex nut (4)	18-8 SS	14. Lever and grip	304 SS w/vinyl

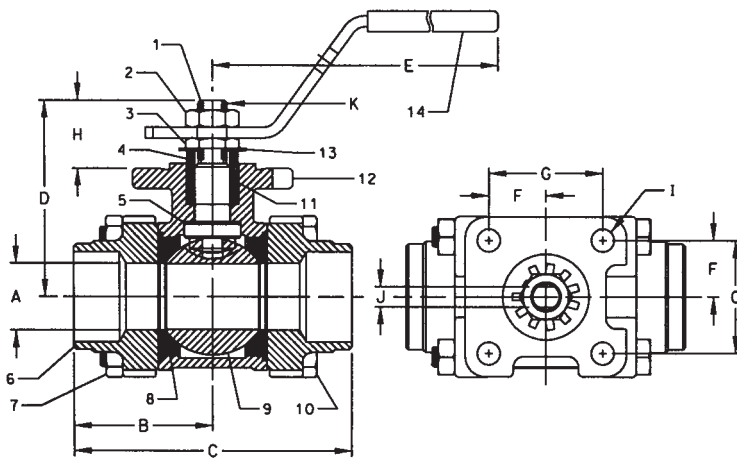

OPTIONS AVAILABLE:

(SUFFIX)	OPTION	SIZES
-02-	Static Grounded	1/2" to 2"
-03-	1-1/4" Stem Extension	1/2" to 2"
-04-	2-1/4" Stem Extension	1/2" to 2"
-08-	90° Reversed Stem	1/2" to 2"
-14-	Vented Ball	1/2" to 2"
-18-	Plain Yellow Grip	1/2" to 2"
-21-	UHMWPE Seats (Non-PTFE)	1/2" to 2"
-24-	Graphite Stem Packing	1/2" to 2"
-27-	Latch Lock Lever	1/2" to 2"
-35-	VTFE Trim	1/2" to 2"
-36-	SS Round Handle	1/4" to 2"
-39-	SS Hi-Rise Locking Wheel Handle, SS Nut	1/2" to 2"
-49-	Assembled Dry	1/2" to 2"
-57-	Oxygen Cleaned	1/2" to 2"
-60-	Grounded Ball & Stem	1/2" to 2"
-AR-	Less Handle & Stop-Add Belleville Washers	1/2" to 2"
-WB-	With Lever & Belleville Washers	1/2" to 2"

**For Pressure/Temperature Ratings,
Refer to Page M-10, Graph No. 8**

STAINLESS STEEL 3-PIECE FULL PORT BUTT WELD BALL VALVE WITH ISO MOUNTING PAD

NUMBER	SIZE	A	B	C	D	E	F	G	H	I	J (FLATS)	K (THRDS.) UNF
86R-703-01	1/2"	.62	1.40	2.81	2.05	4.18	.59	1.17	.61	.28	.247/.249	3/8-24
86R-704-01	3/4"	.81	1.71	3.42	2.42	4.93	.70	1.39	.84	.28	.247/.249	3/8-24
86R-705-01	1"	1.00	1.98	3.97	2.54	4.93	.70	1.39	.84	.28	.247/.249	3/8-24
86R-707-01	1-1/2"	1.50	2.59	5.18	3.49	8.06	.98	1.95	1.16	.34	.370/.372	5/8-18
86R-708-01	2"	2.00	3.01	6.03	3.95	8.06	.98	1.95	1.16	.34	.370/.372	5/8-18



401R-100 Series

Alloy 20 3-Piece Full Port Ball Valve With Actuator Ready ISO Mounting Pad

Full Port Threaded, 1/2" to 1" 1000 psig CWP, 1-1/2" to 3" 800 psig CWP, Cold Non-Shock. 150 psig Saturated Steam Vacuum Service to 29 inches Hg.

Federal Specification: WW-V-35C, Type: II, Composition: SS, Style: 1.

MSS SP-110; Ball Valves, Threaded, Socket-Welding, Solder Joint, Grooved and Flared Ends.

FEATURES

- Multi-piece packing set
- ISO 5211 mounting pad
- Blow-out-proof stem design
- In-line repairable
- Meets NACE MR01-75
- Adjustable packing gland
- Investment cast components
- RPTFE seats and seals
- Full port configuration

STANDARD MATERIAL LIST

1. Stem	B473-N08020	8. Seat (2)	RPTFE
2. Jam nut	SS	9. Ball	B473-N08020
3. Low profile nut	316 SS	10. Body bolt (4)	18-8 SS
4. Gland	A276-316	11. Stem packing	MPTFE
5. Stem bearing	RPTFE	12. Body	ASTM A351-CN7M
6. End cap (2)	ASTM A351-CN7M	13. Lock tab washer	304 SS
7. Hex nut (4)	18-8 SS	14. Lever and grip	304 SS w/vinyl

OPTIONS AVAILABLE:

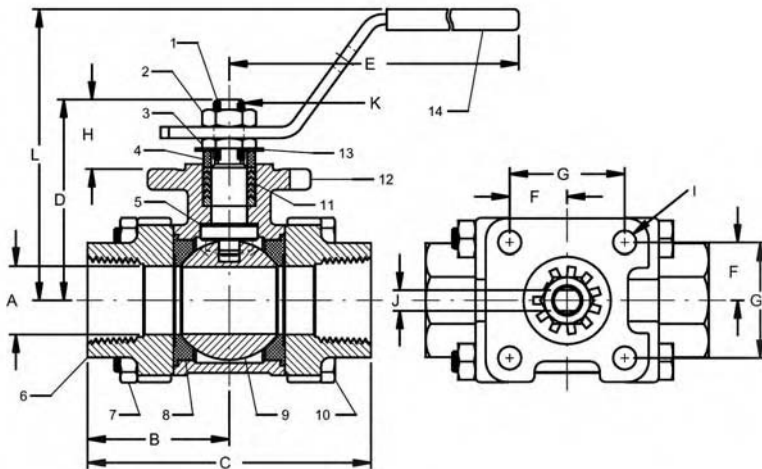

(SUFFIX)	OPTION	SIZES
-02-	Static Grounded	1/2" to 2"
-03-	1-1/4" Stem Extension	1/2" to 2"
-04-	2-1/4" Stem Extension	1/2" to 2"
-08-	90° Reversed Stem	1/2" to 2"
-14-	Vented Ball	1/2" to 2"
-18-	Plain Yellow Grip	1/2" to 2"
-21-	UHMWPE Seats (Non-PTFE)	1/2" to 2"
-24-	Graphite Stem Packing	1/2" to 2"
-27-	Latch Lock Lever	1/2" to 2"
-35-	VTFE Trim	1/2" to 2"
-36-	SS Hi-Rise Round Handle & Nut	1/2" to 2"
-39-	SS Hi-Rise Locking Wheel Handle, SS Nut	1/2" to 2"
-49-	Assembled Dry	1/2" to 2"
-57-	Oxygen Cleaned	1/2" to 2"
-60-	Grounded Ball & Stem	1/2" to 2"
-63-	NPT x Socket weld	1/2" to 2"
-P01-	BSPP (Parallel) Thread Connection	1/2" to 2"
-T01-	BSPT (Tapered) Thread Connection	1/2" to 2"
-AR-	Less Handle & Stop-Add Belleville Washers	1/2" to 2"
-WB-	With Lever & Belleville Washers	1/2" to 2"

**For Pressure/Temperature Ratings,
Refer to Page M-10, Graph No. 8**

ALLOY 20 3-PC. FULL PORT BV WITH ISO MOUNTING PAD

PART #	SIZE	A	B	C	D	E	F	G	H	I	J (Flats)	K (Thrds.) UNF	L
401R10301	1/2"	.62	1.40	2.81	2.05	4.18	.59	1.17	.61	.28	.247/.249	3/8-24	3.28
401R10401	3/4"	.81	1.71	3.42	2.42	4.93	.70	1.39	.84	.28	.247/.249	3/8-24	3.52
401R10501	1"	1.00	1.92	3.85	2.54	4.93	.70	1.39	.84	.28	.247/.249	3/8-24	3.64
401R10601	1-1/4"	1.25	2.35	4.70	3.16	8.06	.98	1.95	1.16	.34	.370/.372	5/8-18	4.05
401R10701	1-1/2"	1.50	2.59	5.18	3.49	8.06	.98	1.95	1.16	.34	.370/.372	5/8-18	4.38
401R10801	2"	2.00	3.01	6.03	3.95	8.06	.98	1.95	1.16	.34	.370/.372	5/8-18	4.85



401R-200 Series

Alloy 20 3-Piece Full Port Socket Weld Ball Valve With Actuator Ready ISO Mounting Pad

Socket Weld, 1/2" to 1" 1000 psig CWP, 1-1/2" & 2" 800 psig CWP, Cold Non-Shock. 150 psig Saturated Steam. Vacuum Service to 29 inches Hg.

Federal Specification: WW-V-35C, Type: II, Composition: SS, Style: 1.

MSS SP-110; Ball Valves, Threaded, Socket-Welding, Solder Joint, Grooved and Flared Ends.

FEATURES

- Multi-piece packing set
- ISO 5211 mounting pad
- Blow-out-proof stem design
- In-line repairable
- Meets NACE MR01-75
- Adjustable packing gland
- Investment cast components
- RPTFE seats and seals
- Full port configuration

STANDARD MATERIAL LIST

1. Stem	B473-N08020	8. Seat (2)	RPTFE
2. Jam nut	SS	9. Ball	B473-N08020
3. Low profile nut	316 SS	10. Body bolt (4)	18-8 SS
4. Gland	A276-316	11. Stem packing	MPTFE
5. Stem bearing	RPTFE	12. Body	ASTM A351-CN7M
6. End cap (2)	ASTM A351-CN7M	13. Lock tab washer	304 SS
7. Hex nut (4)	18-8 SS	14. Lever and grip	304 SS w/vinyl

OPTIONS AVAILABLE:

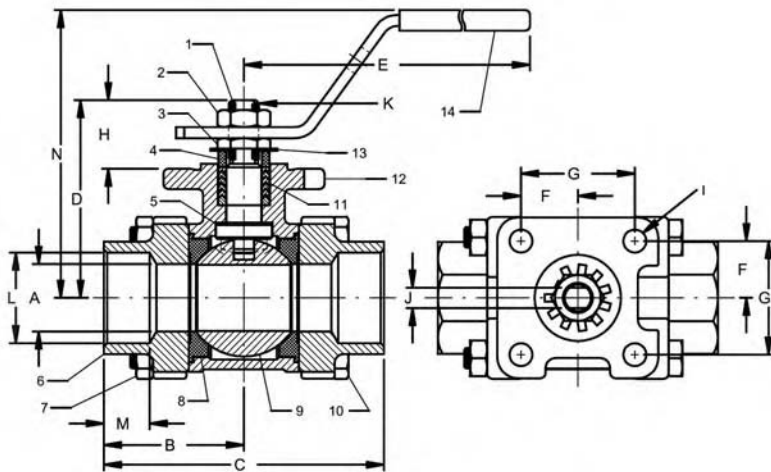

(SUFFIX)	OPTION	SIZES
-02-	Static Grounded	1/2" to 2"
-03-	1-1/4" Stem Extension	1/2" to 2"
-04-	2-1/4" Stem Extension	1/2" to 2"
-08-	90° Reversed Stem	1/2" to 2"
-14-	Vented Ball	1/2" to 2"
-18-	Plain Yellow Grip	1/2" to 2"
-21-	UHMWPE Seats (Non-PTFE)	1/2" to 2"
-24-	Graphite Stem Packing	1/2" to 2"
-27-	Latch Lock Lever	1/2" to 2"
-35-	VTFE Trim	1/2" to 2"
-36-	SS Hi-Rise Round Handle & Nut	1/2" to 2"
-39-	SS Hi-Rise Locking Wheel Handle, SS Nut	1/2" to 2"
-49-	Assembled Dry	1/2" to 2"
-57-	Oxygen Cleaned	1/2" to 2"
-60-	Grounded Ball & Stem	1/2" to 2"
-P01-	BSPP (Parallel) Thread Connection	1/2" to 2"
-T01-	BSPT (Tapered) Thread Connection	1/2" to 2"
-AR-	Less Handle & Stop-Add Belleville Washers	1/2" to 2"
-WB-	With Lever & Belleville Washers	1/2" to 2"

For Pressure/Temperature Ratings, Refer to Page M-10, Graph No. 8

ALLOY 20 3-PC. FULL PORT BV WITH ISO MOUNTING PAD

SIZE	PART #	A	B	C	D	E	F	G	H	I	J (Flats)	K (Thrds.) UNF	L	M	N
1/2"	401R20301	.62	1.40	2.81	2.05	4.18	.59	1.17	.61	.28	.247/.249	3/8-24	.855	.43	3.28
3/4"	401R20401	.81	1.71	3.42	2.42	4.93	.70	1.39	.84	.28	.247/.249	3/8-24	1.065	.56	3.52
1"	401R20501	1.00	1.92	3.85	2.54	4.93	.70	1.39	.84	.28	.247/.249	3/8-24	1.330	.68	3.64
1-1/4"	401R20601	1.25	2.35	4.70	3.16	8.06	.98	1.95	1.16	.34	.370/.372	5/8-18	1.675	.81	4.05
1-1/2"	401R20701	1.50	2.59	5.18	3.49	8.06	.98	1.95	1.16	.34	.370/.372	5/8-18	1.915	.87	4.38
2"	401R20801	2.00	3.01	6.03	3.95	8.06	.98	1.95	1.16	.34	.370/.372	5/8-18	2.405	1.05	4.85



83-300 Series

Carbon Steel 3-Piece High Pressure Ball Valve

Standard Port, Threaded, 1/2" to 1-1/4" 1500 psig WOG, 1-1/2" & 2" 1250 psig WOG, Cold Non-Shock. 150 psig Saturated Steam. Vacuum Service to 29 inches Hg.

Federal Specification: WW-V-35C, Type: II, Composition: CS, Style: 1.

MSS SP-110; Ball Valves Threaded, Socket-Welding, Solder Joint, Grooved and Flared Ends.

FEATURES

- Nitride corrosion protection
- Adjustable packing gland
- In-line repairable
- Blow-out-proof stem design
- (-29) certified to API 607 4TH ed. Class 600 burn
- Meets NACE MR-01-75 with SS trim
- Investment Cast Components
- Actuator mounting pad (1" to 2")
- RPTFE seats and seals

STANDARD MATERIAL LIST

1. Lever and grip	CS, zinc plated w/vinyl	8. Gland nut	A108-CS
2. Body bolt (4)	Steel, SAE grade 8 zinc plated	9. Stem	A108-CS
3. Hex nut (4)	Steel, SAE grade 8 zinc plated	10. Lever nut	Steel, zinc plated
4. Ball	A108-CS chrome plated	11. Stem packing	RPTFE
5. Seat (2)	RPTFE	12. Stem bearing	RPTFE
6. End cap (2)	A216-WCB	13. Body	A216-WCB
7. Seat holder (2)	A108-CS	14. Body seal (2)	RPTFE

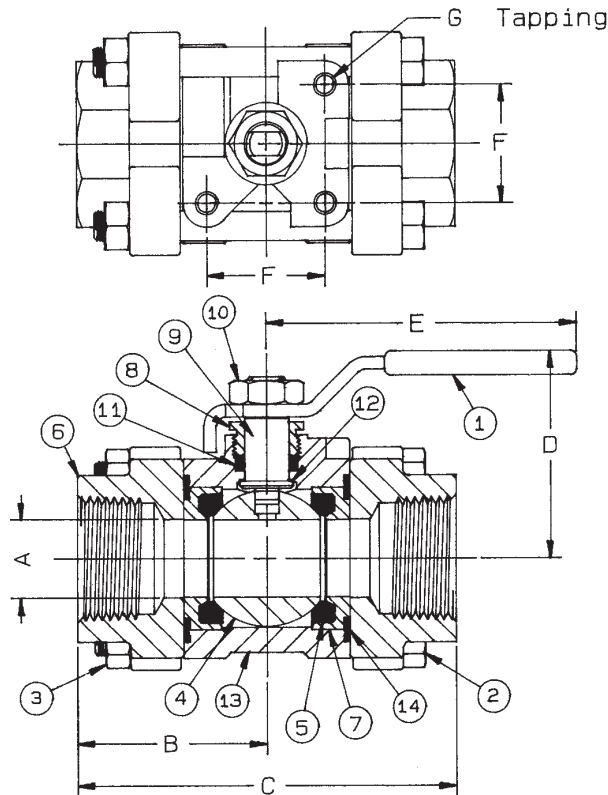

CARBON STEEL 3-PIECE
HIGH PRESSURE BALL VALVE

NUMBER	SIZE	A	B	C	D	E	F	G	Wt.
83-303-01	1/2"	.50	1.50	3.00	1.84	3.87	N/A	N/A	1.28
83-304-01	3/4"	.62	1.87	3.74	2.00	4.87	N/A	N/A	2.00
83-305-01A	1"	.81	1.99	3.99	2.18	4.87	1.25	1/4-20	2.69
83-306-01A	1-1/4"	1.00	2.31	4.62	2.60	5.50	1.62	5/16-18	3.97
83-307-01A	1-1/2"	1.25	2.62	5.25	2.82	5.50	1.62	5/16-18	5.50
83-308-01A	2"	1.50	2.74	5.48	3.37	8.00	1.62	5/16-18	8.05

VARIATIONS AVAILABLE:

83-340 Series (316 SS Ball & Stem)

OPTIONS AVAILABLE:

(SUFFIX)	OPTION	SIZES
-02-	Static Grounded	1/2" to 2"
-03-	1-1/4" Stem Extension	1/2" to 2"
-04-	2-1/4" Stem Extension	1/2" to 2"
-07-	Tee Handle	1/2" to 2"
-08-	90° Reversed Stem	1/2" to 2"
-10-	SS Lever & Nut	1/2" to 2"
-14-	Vented Ball (see page J-2)	1/2" to 2"
-15-	Round Handle	1/2" to 2"
-16-	Vertical Chain Lever	3/4" to 2"
-18-	Plain Yellow Grip	1/2" to 2"
-27-	Latch Lock Lever	3/4" to 2"
-29-	Firesafe	1/2" to 2"
-32-	SS Tee Handle & Nut	1/2" to 2"
-45-	Less Lever & Nut	1/2" to 2"
-48-	SS Oval Handle (No Latch) & Nut	1/2" to 2"
-56-	Multifill Seats	1/2" to 2"
-58-	Chain Lever - Horizontal	3/4" to 2"
-59-	SS External Trim - 3-pc. Valves	1/2" to 2"
-60-	Grounded Ball & Stem	1/2" to 2"
-63-	NPT x Solder/Socket Weld	1/2" to 2"
-64-	250# Steam Trim	1/2" to 2"
-P01-	BSPP (Parallel) Thread Connection	1/2" to 2"
-T01-	BSPT (Tapered) Thread Connection	1/2" to 2"

**For Pressure/Temperature Ratings,
Refer to Page M-11, Graph No. 11**



83-400 Series

Carbon Steel 3-Piece High Pressure Socket Weld Ball Valve

Standard Port, Socket Weld, 1/2" to 1-1/4" 1500 psig WOG, 1-1/2" & 2" 1250 psig WOG, Cold Non-Shock. 150 psig Saturated Steam. Vacuum Service to 29 inches Hg.

Federal Specification: WW-V-35C, Type: II, Composition: CS, Style: 1.

MSS SP-110; Ball Valves Threaded, Socket-Welding, Solder Joint, Grooved and Flared Ends.

FEATURES

- Nitride corrosion protection
- Adjustable packing gland
- In-line repairable
- Blow-out-proof stem design
- (-29) certified to API 607 4TH ed. Class 600 burn
- Meets NACE MR-01-75 with SS trim
- Investment Cast Components
- Actuator mounting pad (1" to 2")
- RPTFE seats and seals

STANDARD MATERIAL LIST

1. Lever and grip	CS, zinc plated w/vinyl	8. Gland nut	A108-CS
2. Body bolt (4)	Steel, SAE grade 8 zinc plated	9. Stem	A108-CS
3. Hex nut (4)	Steel, SAE grade 8 zinc plated	10. Lever nut	Steel, zinc plated
4. Ball	A108-CS chrome plated	11. Stem packing	RPTFE
5. Seat (2)	RPTFE	12. Stem bearing	RPTFE
6. End cap (2)	A216-WCB	13. Body	A216-WCB
7. Seat holder (2)	A108-CS	14. Body seal (2)	RPTFE

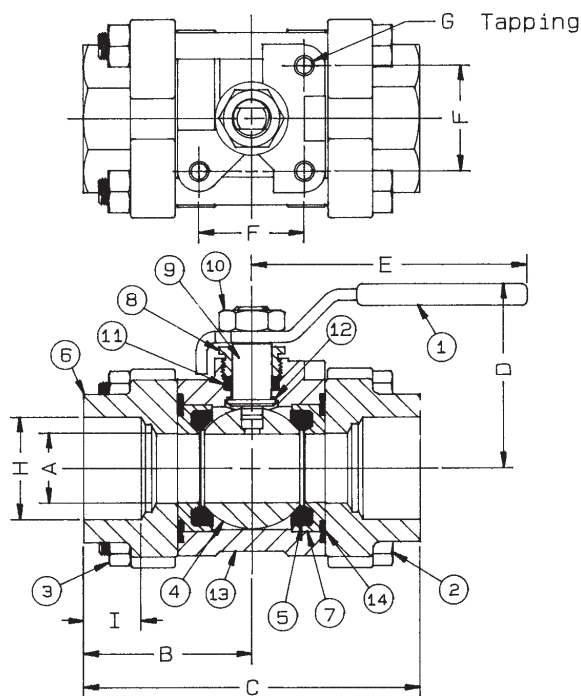

CARBON STEEL 3-PIECE HIGH PRESSURE SOCKET WELD BALL VALVE

VARIATIONS AVAILABLE:

83-440 Series (316 SS Ball & Stem)

OPTIONS AVAILABLE:

(SUFFIX)	OPTION	SIZES
-02-	Static Grounded	1/2" to 2"
-03-	1-1/4" Stem Extension	1/2" to 2"
-04-	2-1/4" Stem Extension	1/2" to 2"
-07-	Tee Handle	1/2" to 2"
-08-	90° Reversed Stem	1/2" to 2"
-10-	SS Lever & Nut	1/2" to 2"
-14-	Vented Ball (see page J-2)	1/2" to 2"
-15-	Round Handle	1/2" to 2"
-16-	Vertical Chain Lever	3/4" to 2"
-18-	Plain Yellow Grip	1/2" to 2"
-27-	Latch Lock Lever	3/4" to 2"
-29-	Firesafe	1/2" to 2"
-32-	SS Tee Handle & Nut	1/2" to 2"
-45-	Less Lever & Nut	1/2" to 2"
-48-	SS Oval Handle (No Latch) & Nut	1/2" to 2"
-56-	Multifill Seats	1/2" to 2"
-58-	Chain Lever - Horizontal	3/4" to 2"
-59-	SS External Trim - 3-pc. Valves	1/2" to 2"
-60-	Grounded Ball & Stem	1/2" to 2"
-64-	250# Steam Trim	1/2" to 2"

For Pressure/Temperature Ratings, Refer to Page M-11, Graph No. 11

NUMBER	SIZE	A	B	C	D	E	F	G	H	I	Wt.
83-403-01	1/2"	.50	1.50	3.00	1.84	3.87	N/A	N/A	.855	.43	1.28
83-404-01	3/4"	.62	1.87	3.74	2.00	4.87	N/A	N/A	1.065	.56	2.00
83-405-01A	1"	.81	1.99	3.99	2.18	4.87	1.25	1/4-20	1.330	.68	2.69
83-406-01A	1-1/4"	1.00	2.31	4.62	2.60	5.50	1.62	5/16-18	1.675	.81	3.97
83-407-01A	1-1/2"	1.25	2.62	5.25	2.82	5.50	1.62	5/16-18	1.915	.87	5.50
83-408-01A	2"	1.50	2.74	5.48	3.37	8.00	1.62	5/16-18	2.406	1.06	8.05



83-500 Series

Carbon Steel 3-Piece High Pressure Full Port Ball Valve

Threaded, 1/4" to 1" 1500 psig WOG, 1-1/4" & 2" 1250 psig WOG, Cold Non-Shock. 150 psig Saturated Steam. Vacuum Service to 29 inches Hg.

Federal Specification: WW-V-35C, Type: II, Composition: CS, Style: 1.

MSS SP-110; Ball Valves Threaded, Socket-Welding, Solder Joint, Grooved and Flared Ends.

FEATURES

- Nitride corrosion protection
- Adjustable packing gland
- In-line repairable
- Blow-out-proof stem design
- (-29) Certified to API standard 607, 4th Edition, Class 600 burn
- Meets NACE MR-01-75 with SS trim
- Investment Cast Components
- Actuator mounting pad (3/4" to 2")
- RPTFE seats and seals

STANDARD MATERIAL LIST

1. Lever and grip	CS, zinc plated w/vinyl	8. Gland nut	A108-CS
2. Body bolt (4)	Steel, SAE grade 8 zinc plated	9. Stem	A108-CS
3. Hex nut (4)	Steel, SAE grade 8 zinc plated	10. Lever nut	Steel, zinc plated
4. Ball	A108-CS chrome plated	11. Stem packing	RPTFE
5. Seat (2)	RPTFE	12. Stem bearing	RPTFE
6. End cap (2)	A216-WCB	13. Body	A216-WCB
7. Seat holder (2)	A108-CS	14. Body seal (2)	RPTFE

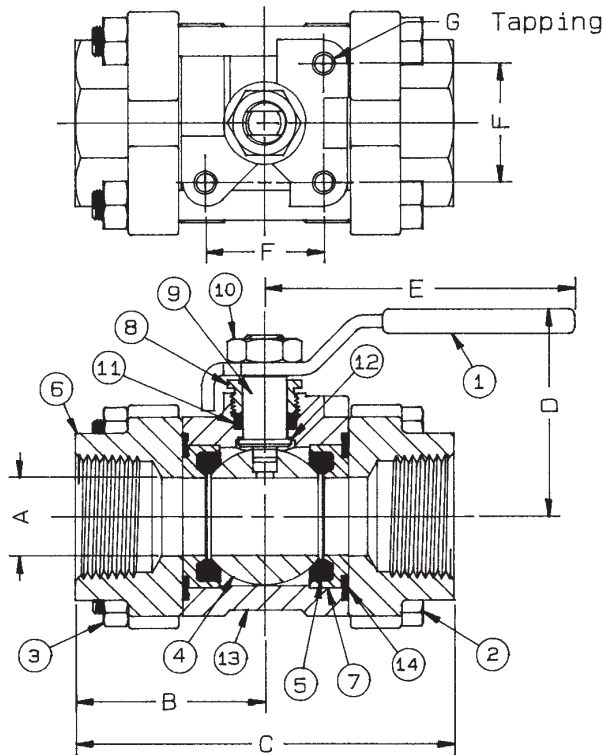

CARBON STEEL 3-PIECE HIGH PRESSURE FULL PORT BALL VALVE

VARIATIONS AVAILABLE:

83-540 Series (316 SS Ball & Stem)

OPTIONS AVAILABLE:

(SUFFIX)	OPTION	SIZES
-02-	Static Grounded	1/4" to 2"
-03-	1-1/4" Stem Extension	1/4" to 2"
-04-	2-1/4" Stem Extension	1/4" to 2"
-07-	Tee Handle	1/4" to 2"
-08-	90° Reversed Stem	1/4" to 2"
-10-	SS Lever & Nut	1/4" to 2"
-14-	Vented Ball (see page J-2)	1/4" to 2"
-16-	Vertical Chain Lever	1/2" to 2"
-18-	Plain Yellow Grip	1/4" to 2"
-27-	Latch Lock Lever	1/4" to 2"
-29-	Firesafe	1/4" to 2"
-32-	SS Tee Handle & Nut	1/4" to 2"
-38-	PEEK Seats & Bearing (Graphite Packing & Seals)	1/4" to 2"
-45-	Less Lever & Nut	1/4" to 2"
-47-	SS Latch-Lock Oval Handle	1/4" to 2"
-48-	SS Oval Handle (No Latch) & Nut	1/4" to 2"
-56-	Multifill Seats	1/4" to 2"
-58-	Chain Lever - Horizontal	1/2" to 2"
-59-	SS External Trim - 3-pc. Valves	1/4" to 2"
-60-	Grounded Ball & Stem	1/4" to 2"
-63-	Female Threaded x Socket Weld	1/4" to 2"
-64-	250# Steam Trim	1/4" to 2"
-P01-	BSPP (Parallel) Thread Connection	1/4" to 2"
-T01-	BSPT (Tapered) Thread Connection	1/4" to 2"

NUMBER	SIZE	A	B	C	D	E	F	G	Wt.
83-501-01	1/4"	.43	1.50	3.00	1.93	3.87	N/A	N/A	1.21
83-502-01	3/8"	.50	1.50	3.00	1.93	3.87	N/A	N/A	1.22
83-503-01	1/2"	.62	1.69	3.38	2.00	4.81	N/A	N/A	1.90
83-504-01A	3/4"	.81	1.93	3.87	2.18	4.81	1.25	1/4-20	2.56
83-505-01A	1"	1.00	2.25	4.50	2.62	5.50	1.62	5/16-18	3.78
83-506-01A	1-1/4"	1.25	2.43	4.87	2.87	5.50	1.62	5/16-18	5.24
83-507-01A	1-1/2"	1.50	2.62	5.25	3.35	8.00	1.62	5/16-18	7.67
83-508-01A	2"	2.00	3.12	6.25	3.75	8.00	1.62	5/16-18	15.60

For Pressure/Temperature Ratings, Refer to Page M-11, Graph No. 11



83-600 Series

Carbon Steel 3-Piece High Pressure Full Port Socket Weld Ball Valve

Socket Weld, 1/2" to 1" 1500 psig WOG, 1-1/4" & 2" 1250 psig WOG, Cold Non-Shock. 150 psig Saturated Steam. Vacuum Service to 29 inches Hg.

Federal Specification: WW-V-35C, Type: II, Composition: CS, Style: 1.

MSS SP-110; Ball Valves Threaded, Socket-Welding, Solder Joint, Grooved and Flared Ends.

FEATURES

- Nitride corrosion protection
- Adjustable packing gland
- In-line repairable
- Blow-out-proof stem design
- (-29) Certified to API standard 607, 4th Edition, Class 600 burn
- Meets NACE MR-01-75 with SS trim
- Investment Cast Components
- Actuator mounting pad (3/4" to 2")
- RPTFE seats and seals

STANDARD MATERIAL LIST

1. Lever and grip	CS, zinc plated w/vinyl	8. Gland nut	A108-CS
2. Body bolt (4)	Steel, SAE grade 8 zinc plated	9. Stem	A108-CS
3. Hex nut (4)	Steel, SAE grade 8 zinc plated	10. Lever nut	Steel, zinc plated
4. Ball	A108-CS chrome plated	11. Stem packing	RPTFE
5. Seat (2)	RPTFE	12. Stem bearing	RPTFE
6. End cap (2)	A216-WCB	13. Body	A216-WCB
7. Seat holder (2)	A108-CS	14. Body seal (2)	RPTFE

VARIATIONS AVAILABLE:

83-640 Series (316 SS Ball & Stem)

OPTIONS AVAILABLE:

(SUFFIX)	OPTION	SIZES
-02-	Static Grounded	1/2" to 2"
-03-	1-1/4" Stem Extension	1/2" to 2"
-04-	2-1/4" Stem Extension	1/2" to 2"
-07-	Tee Handle	1/2" to 2"
-08-	90° Reversed Stem	1/2" to 2"
-10-	SS Lever & Nut	1/2" to 2"
-14-	Vented Ball (see page J-2)	1/2" to 2"
-15-	Round Handle	1/2" to 2"
-16-	Vertical Chain Lever	1/2" to 2"
-18-	Plain Yellow Grip	1/2" to 2"
-27-	Latch Lock Lever	1/2" to 2"
-29-	Firesafe	1/2" to 2"
-32-	SS Tee Handle & Nut	1/2" to 2"
-38-	PEEK Seats & Bearing (Graphite Packing & Seals)	1/2" to 2"
-45-	Less Lever & Nut	1/2" to 2"
-47-	SS Latch-Lock Oval Handle	1/2" to 2"
-48-	SS Oval Handle (No Latch) & Nut	1/4" to 2"
-56-	Multifill Seats	1/2" to 2"
-58-	Chain Lever - Horizontal	1/2" to 2"
-59-	SS External Trim - 3-pc. Valves	1/2" to 2"
-60-	Grounded Ball & Stem	1/2" to 2"
-64-	250# Steam Trim	1/2" to 2"

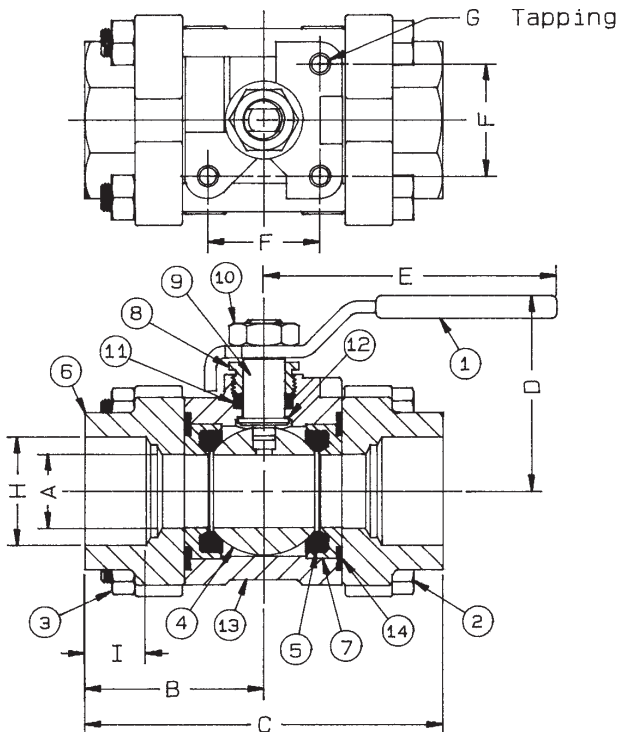

CARBON STEEL 3-PIECE HIGH PRESSURE FULL PORT SOCKET WELD BALL VALVE

For Pressure/Temperature Ratings, Refer to Page M-11, Graph No. 11

NUMBER	SIZE	A	B	C	D	E	F	G	H	I	Wt.
83-603-01	1/2"	.62	1.69	3.38	2.00	4.81	N/A	N/A	.855	.43	1.90
83-604-01A	3/4"	.81	1.93	3.87	2.18	4.81	1.25	1/4-20	1.065	.56	2.56
83-605-01A	1"	1.00	2.25	4.50	2.62	5.50	1.62	5/16-18	1.330	.68	3.78
83-606-01A	1-1/4"	1.25	2.43	4.87	2.87	5.50	1.62	5/16-18	1.675	.81	5.24
83-607-01A	1-1/2"	1.50	2.62	5.25	3.35	8.00	1.62	5/16-18	1.915	.87	7.67
83-608-01A	2"	2.00	3.12	6.25	3.75	8.00	1.62	5/16-18	2.406	1.06	15.60



85-100 Series

Stainless Steel 3-Piece Ball Valve

Standard Port Threaded, 1000 psig WOG, Cold Non-Shock. 150 psig Saturated Steam.

Vacuum Service to 29 inches Hg.

Federal Specification: WW-V-35C, Type: II, Composition: SS, Style: 1.

MSS SP-110; Ball Valves Threaded, Socket-Welding, Solder Joint, Grooved and Flared Ends.

FEATURES

- Meets NACE MR-01-75
- Blow-out-proof stem design
- In-line repairable
- Investment cast components
- RPTFE seats and seals
- Adjustable packing gland

STANDARD MATERIAL LIST

1. Lever and grip	304 SS w/vinyl	7. Gland nut	A276-316
2. Stem packing	RPTFE	8. Stem	A276-316
3. Stem bearing	RPTFE	9. Lever nut	18-8 SS
4. Ball	A276-316	10. Body bolt (4)	18-8 SS
5. Seat (2)	RPTFE	11. Hex nut (4)	18-8 SS
6. End cap (2)	A351-CF3M	12. Body	A351-CF8M

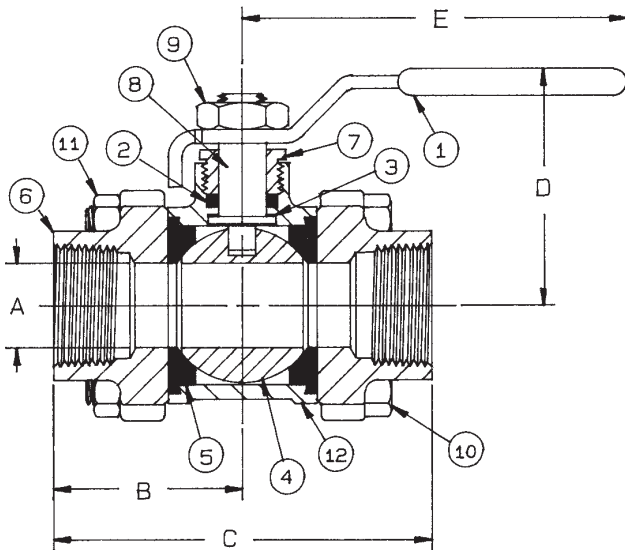

OPTIONS AVAILABLE:

(SUFFIX)	OPTION	SIZES
-02-	Static Grounded	1/2"
-03-	1-1/4" Stem Extension	1/2"
-04-	2-1/4" Stem Extension	1/2"
-07-	Tee Handle	1/2"
-08-	90° Reversed Stem	1/2"
-14-	Vented Ball (see page J-2)	1/2"
-15-	Round Handle	1/2"
-18-	Plain Yellow Grip	1/2"
-24-	Graphite Stem Packing	1/2"
-27-	Latch Lock Lever	1/2"
-32-	SS Tee Handle & Nut	1/2"
-35-	VTFE Trim	1/2"
-45-	Less Lever & Nut	1/2"
-47-	SS Latch-Lock Oval Handle	1/2"
-48-	SS Oval Handle (No Latch) & Nut	1/2"
-49-	Assembled Dry	1/2"
-50-	2-1/4" CS Locking Stem Extension	1/2"
-57-	Oxygen Cleaned	1/2"
-60-	Grounded Ball & Stem	1/2"
-61-	Grounded Ball & Stem and Assembled Dry	1/2"
-63-	Threaded x Socket Weld	1/2"
-P01-	BSPP (Parallel) Thread Connection	1/2"
-T01-	BSPT (Tapered) Thread Connection	1/2"

STAINLESS STEEL 3-PIECE BALL VALVE

NUMBER	SIZE	A	B	C	D	E	F	G	Wt.
85-101-01	1/4"	.43	1.28	2.56	1.81	3.87	N/A	N/A	1.02
85-102-01	3/8"	.50	1.28	2.56	1.81	3.87	N/A	N/A	.98
85-103-01	1/2"	.50	1.28	2.56	1.81	3.87	N/A	N/A	.97

**For Pressure/Temperature Ratings,
Refer to Page M-10, Graph No. 8**



85-200 Series

Stainless Steel 3-Piece Socket Weld Ball Valve

Standard Port Socket Weld, 1000 psig WOG, Cold Non-Shock. 150 psig Saturated Steam.
Vacuum Service to 29 inches Hg.

Federal Specification: WW-V-35C, Type: II, Composition: SS, Style: 1.

MSS SP-110; Ball Valves Threaded, Socket-Welding, Solder Joint, Grooved and Flared Ends.

FEATURES

- Meets NACE MR-01-75
- Blow-out-proof stem design
- In-line repairable
- Investment cast components
- RPTFE seats and seals
- Adjustable packing gland

STANDARD MATERIAL LIST

1. Lever and grip	304 SS w/vinyl	7. Gland nut	A276-316
2. Stem packing	RPTFE	8. Stem	A276-316
3. Stem bearing	RPTFE	9. Lever nut	18-8 SS
4. Ball	A276-316	10. Body bolt (4)	18-8 SS
5. Seat (2)	RPTFE	11. Hex nut (4)	18-8 SS
6. End cap (2)	A351-CF3M	12. Body	A351-CF8M

OPTIONS AVAILABLE:

(SUFFIX)	OPTION	SIZES
-02-	Static Grounded	1/2"
-03-	1-1/4" Stem Extension	1/2"
-04-	2-1/4" Stem Extension	1/2"
-07-	Tee Handle	1/2"
-08-	90° Reversed Stem	1/2"
-14-	Vented Ball (see page J-2)	1/2"
-15-	Round Handle	1/2"
-18-	Plain Yellow Grip	1/2"
-24-	Graphite Stem Packing	1/2"
-27-	Latch Lock Lever	1/2"
-32-	SS Tee Handle & Nut	1/2"
-35-	VTFE Trim	1/2"
-45-	Less Lever & Nut	1/2"
-47-	SS Latch-Lock Oval Handle	1/2"
-48-	SS Oval Handle (No Latch) & Nut	1/2"
-49-	Assembled Dry	1/2"
-57-	Oxygen Cleaned	1/2"
-60-	Grounded Ball & Stem	1/2"

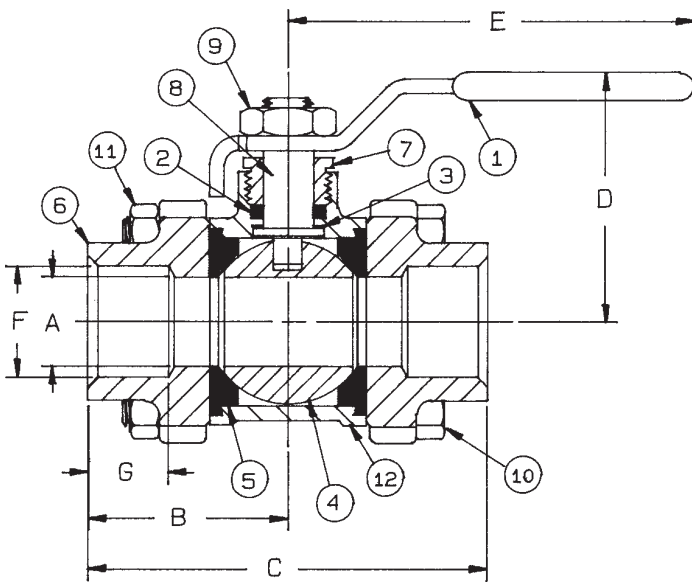

**For Pressure/Temperature Ratings,
Refer to Page M-10, Graph No. 8**

STAINLESS STEEL 3-PIECE SOCKET WELD BALL VALVE

NUMBER	SIZE	A	B	C	D	E	F	G	H	I	Wt.
85-203-01	1/2"	.50	1.28	2.56	1.81	3.87	N/A	N/A	.855	.43	.97



86-500 Series

Stainless Steel 3-Piece High Pressure Full Port Ball Valve

Threaded, 1/4" to 1" 1500 psig WOG, 1-1/4" & 2" 1250 psig WOG, Cold Non-Shock. 150 psig Saturated Steam. Vacuum Service to 29 inches Hg.

Federal Specification: WW-V-35C, Type: II, Composition: SS, Style: 1.

MSS SP-110; Ball Valves Threaded, Socket-Welding, Solder Joint, Grooved and Flared Ends.

FEATURES

- Adjustable packing gland
- In-line repairable
- Blow-out-proof stem design
- (-29) Certified to API standard 607, 4th Edition, Class 600 burn
- Meets NACE MR-01-75
- Investment Cast Components
- Actuator mounting pad (3/4" to 2")
- RPTFE seats and seals

STANDARD MATERIAL LIST

1. Lever and grip	304 SS w/vinyl	8. Gland nut	A276-316
2. Stem packing	RPTFE	9. Stem	A276-316
3. Stem bearing	RPTFE	10. Lever nut	304 SS
4. Ball	A276-316	11. Body bolt (4)	18-8 SS
5. Seat (2)	RPTFE	12. Hex nut (4)	18-8 SS
6. End cap (2)	A351-CF3M	13. Body	A351-CF8M
7. Seat holder (2)	A276-316	14. Body seal (2)	RPTFE

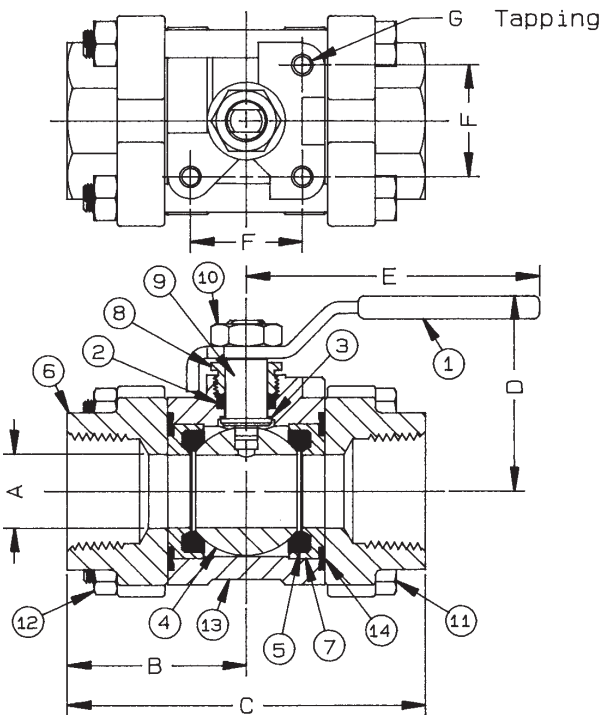

STAINLESS STEEL 3-PIECE HIGH PRESSURE FULL PORT BALL VALVE

NUMBER	SIZE	A	B	C	D	E	F	G	Wt.
86-501-01	1/4"	.43	1.50	3.00	1.93	3.87	N/A	N/A	1.23
86-502-01	3/8"	.50	1.50	3.00	1.93	3.87	N/A	N/A	1.18
86-503-01	1/2"	.62	1.69	3.38	2.00	4.81	N/A	N/A	1.62
86-504-01A	3/4"	.81	1.93	3.87	2.18	4.81	1.25	1/4-20	2.27
86-505-01A	1"	1.00	2.25	4.50	2.62	5.50	1.62	5/16-18	3.54
86-506-01A	1-1/4"	1.25	2.43	4.87	2.87	5.50	1.62	5/16-18	6.00
86-507-01A	1-1/2"	1.50	2.62	5.25	3.35	8.00	1.62	5/16-18	8.84
86-508-01A	2"	2.00	3.12	6.25	3.75	8.00	1.62	5/16-18	15.28

OPTIONS AVAILABLE:

(SUFFIX)	OPTION	SIZES
-02-	Static Grounded	1/4" to 2"
-03-	1-1/4" Stem Extension	1/4" to 2"
-04-	2-1/4" Stem Extension	1/4" to 2"
-07-	Tee Handle	1/4" to 2"
-08-	90° Reversed Stem	1/4" to 2"
-14-	Vented Ball (see page J-2)	1/4" to 2"
-15-	Round Handle	1/4" to 2"
-16-	Vertical Chain Lever	1/2" to 2"
-18-	Plain Yellow Grip	1/4" to 2"
-27-	Latch Lock Lever	1/4" to 2"
-29-	Firesafe	1/4" to 2"
-32-	SS Tee Handle & Nut	1/4" to 2"
-38-	PEEK Seats & Bearing (Graphite Packing & Seals)	1/4" to 2"
-45-	Less Lever & Nut	1/4" to 2"
-47-	SS Latch-Lock Oval Handle	1/4" to 2"
-48-	SS Oval Handle (No Latch) & Nut	1/4" to 2"
-49-	Assembled Dry	1/4" to 2"
-56-	Multifull Seats	1/4" to 2"
-57-	Oxygen Cleaned	1/4" to 2"
-58-	Chain Lever - Horizontal	1/2" to 2"
-60-	Grounded Ball & Stem	1/4" to 2"
-63-	Threaded x Socket Weld	1/2" to 2"
-64-	250# Steam Trim	1/4" to 2"
-66-	FNPT x Butt Weld	1/2" to 2"
-P01-	BSPP (Parallel) Thread Connection	1/4" to 2"
-T01-	BSPT (Tapered) Thread Connection	1/4" to 2"

For Pressure/Temperature Ratings, Refer to Page M-11, Graph No. 12



86-600 Series

Stainless Steel 3-Piece High Pressure Full Port Socket Weld Ball Valve

Socket Weld, 1/2" to 1" 1500 psig WOG, 1-1/4" & 2" 1250 psig WOG, Cold Non-Shock. 150 psig Saturated Steam.

Vacuum Service to 29 inches Hg.

Federal Specification: WW-V-35C, Type: II, Composition: SS, Style: 1.

MSS SP-110; Ball Valves Threaded, Socket-Welding, Solder Joint, Grooved and Flared Ends.

FEATURES

- Adjustable packing gland
- In-line repairable
- Blow-out-proof stem design
- (-29) certified to API 607 4th ed. Class 600 burn
- Meets NACE MR-01-75
- Investment Cast Components
- Actuator mounting pad (3/4" to 2")
- RPTFE seats and seals

STANDARD MATERIAL LIST

1. Lever and grip	304 SS w/vinyl	8. Gland nut	A276-316
2. Stem packing	RPTFE	9. Stem	A276-316
3. Stem bearing	RPTFE	10. Lever nut	18-8 SS
4. Ball	A276-316	11. Body bolt (4)	18-8 SS
5. Seat (2)	RPTFE	12. Hex nut (4)	18-8 SS
6. End cap (2)	A351-CF3M	13. Body	A351-CF8M
7. Seat holder (2)	A276-316	14. Body seal (2)	RPTFE

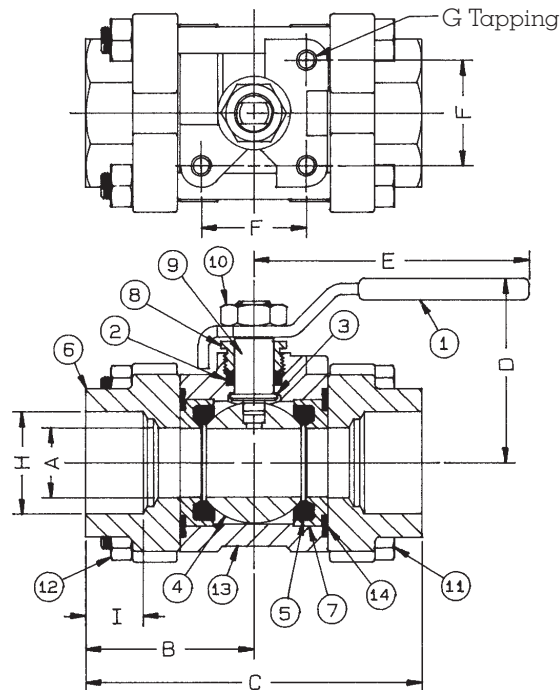

STAINLESS STEEL 3-PIECE HIGH PRESSURE FULL PORT SOCKET WELD BALL VALVE

OPTIONS AVAILABLE:

(SUFFIX)	OPTION	SIZES
-02-	Static Grounded	1/2" to 2"
-03-	1-1/4" Stem Extension	1/2" to 2"
-04-	2-1/4" Stem Extension	1/2" to 2"
-07-	Tee Handle	1/2" to 2"
-08-	90° Reversed Stem	1/2" to 2"
-14-	Vented Ball (see page J-2)	1/2" to 2"
-15-	Round Handle	1/2" to 2"
-16-	Vertical Chain Lever	1/2" to 2"
-18-	Plain Yellow Grip	1/2" to 2"
-27-	Latch Lock Lever	1/2" to 2"
-29-	Firesafe	1/2" to 2"
-32-	SS Tee Handle & Nut	1/2" to 2"
-38-	PEEK Seats & Bearing (Graphite Packing & Seals)	1/2" to 2"
-45-	Less Lever & Nut	1/2" to 2"
-48-	SS Oval Handle (No Latch) & Nut	1/2" to 2"
-49-	Assembled Dry	1/2" to 2"
-56-	Multifill Seats	1/2" to 2"
-57-	Oxygen Cleaned	1/2" to 2"
-58-	Chain Lever - Horizontal	1/2" to 2"
-60-	Grounded Ball & Stem	1/2" to 2"
-64-	250# Steam Trim	1/2" to 2"

**For Pressure/Temperature Ratings,
Refer to Page M-11, Graph No. 12**

NUMBER	SIZE	A	B	C	D	E	F	G	H	I	Wt.
86-603-01	1/2"	.62	1.69	3.38	2.00	4.81	N/A	N/A	.855	.43	1.60
86-604-01A	3/4"	.81	1.93	3.87	2.18	4.81	1.25	1/4-20	1.065	.56	2.24
86-605-01A	1"	1.00	2.25	4.50	2.62	5.50	1.62	5/16-18	1.330	.68	3.32
86-606-01A	1-1/4"	1.25	2.43	4.87	2.87	5.50	1.62	5/16-18	1.675	.81	5.85
86-607-01A	1-1/2"	1.50	2.62	5.25	3.35	8.00	1.62	5/16-18	1.915	.87	8.62
86-608-01A	2"	2.00	3.12	6.25	3.75	8.00	1.62	5/16-18	2.406	1.06	15.60



86-900 Series

Stainless Steel 3-Piece High Pressure Full Port Butt-Weld Ball Valve

Schedule 10 Butt-Weld, 1/2" to 1" 1500 psig WOG, 1-1/2" & 2" 1250 psig WOG, Cold Non-Shock. 150 psig Saturated Steam.

Vacuum Service to 29 inches Hg.

Federal Specification: WW-V-35C, Type: II, Composition: SS, Style: 1.

MSS SP-110; Ball Valves Threaded, Socket-Welding, Solder Joint, Grooved and Flared Ends.

MSS SP-72; Ball Valves with Flanged or Buttweld Ends for General Service

FEATURES

- Adjustable packing gland
- In-line repairable
- Blow-out-proof stem design
- (-29) Certified to API standard 607, 4th Edition, Class 600 burn
- Meets NACE MR-01-75-97
- Investment Cast Components
- Actuator mounting pad (3/4" to 2")
- RPTFE seats and seals

STANDARD MATERIAL LIST

1. Lever and grip	304 SS w/vinyl	8. Gland nut	A276-316
2. Stem packing	RPTFE	9. Stem	A276-316
3. Stem bearing	RPTFE	10. Lever nut	304 SS
4. Ball	A276-316	11. Body bolt (4)	18-8 SS
5. Seat (2)	RPTFE	12. Hex nut (4)	18-8 SS
6. End cap (2)	A351-CF3M	13. Body	A351-CF8M
7. Seat Holder (2)	A276-316	14. Body seal (2)	RPTFE

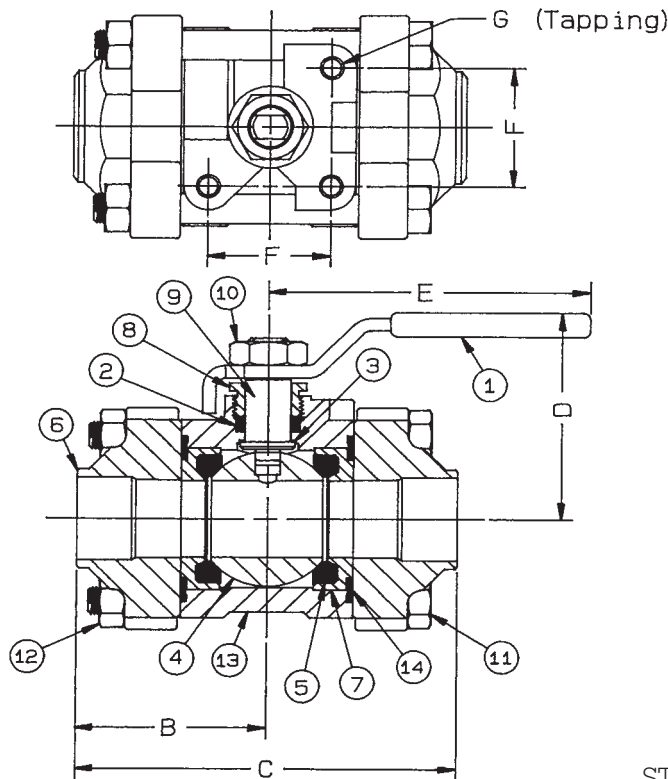

OPTIONS AVAILABLE:

(SUFFIX)	OPTION	SIZES
-02-	Static Grounded	1/2" to 2"
-03-	1-1/4" Stem Extension	1/2" to 2"
-04-	2-1/4" Stem Extension	1/2" to 2"
-07-	Tee Handle	1/2" to 2"
-08-	90° Reversed Stem	1/2" to 2"
-14-	Vented Ball (see page J-2)	1/2" to 2"
-15-	Round Handle	1/2" to 2"
-16-	Vertical Chain Lever	1/2" to 2"
-18-	Plain Yellow Grip	1/2" to 2"
-27-	Latch Lock Lever	1/2" to 2"
-29-	Firesafe	1/2" to 2"
-32-	SS Tee Handle & Nut	1/2" to 2"
-35-	VTFE Trim	1/2" to 2"
-38-	PEEK Seats & Bearing (Graphite Packing & Seals)	1/2" to 2"
-45-	Less Lever & Nut	1/2" to 2"
-47-	SS Latch-Lock Oval Handle	1/2" to 2"
-48-	SS Oval Handle (No Latch) & Nut	1/2" to 2"
-49-	Assembled Dry	1/2" to 2"
-57-	Oxygen Cleaned	1/2" to 2"
-58-	Chain Lever - Horizontal	1/2" to 2"
-60-	Grounded Ball & Stem	1/2" to 2"
-64-	250# Steam Trim	1/2" to 2"

**For Pressure/Temperature Ratings,
Refer to Page M-11, Graph No. 12**

STAINLESS STEEL 3-PIECE HIGH PRESSURE FULL PORT BUTT-WELD BALL VALVE

NUMBER	SIZE	A	B	C	D	E	F	G	Wt.
86-903-01	1/2"	.62	1.69	3.38	2.00	4.81	N/A	N/A	1.60
86-904-01A	3/4"	.81	1.93	3.87	2.18	4.81	1.25	1/4-20	2.24
86-905-01A	1"	1.00	2.25	4.50	2.62	5.50	1.62	5/16-18	3.32
86-907-01A	1-1/2"	1.50	2.62	5.25	3.35	8.00	1.62	5/16-18	8.62
86-908-01A	2"	2.00	3.11	6.22	3.75	8.00	1.62	5/16-18	15.60



83A-140 Series

3-Piece Full Port Carbon Steel 1500 CWP NPT Ball Valve

Standard Compliance - Valve design: MSS SP-110, End Connections: NPT per ASME B1.20.1,
Valve Marking: MSS SP-25, Production Testing: MSS SP-110, NACE MR0175, 2000 edition.

FEATURES

- 3-Piece construction w/ enclosed fasteners
- Full port
- Stainless steel trim & hardware
- Swing-out center section
- Pressure balanced solid ball
- Compression controlled RPTFE gaskets
- Anti-blowout one piece bottom entry stem
- Two-position locking
- Adjustable multi-piece PTFE "V" style packing
- Fully machined ISO 5211 mounting
- Cast bosses on the centersection and end caps for bleed & drain ports
- Vacuum service to 29 in of Hg.

STANDARD MATERIAL LIST

1. Body	ASTM A216-WCB	10. Body Nuts	18-8 Stainless Steel
2. End Caps	ASTM A216-WCB	11. Stop Bolts	18-8 Stainless Steel
3. Ball	ASTM A276-316SS	12. Gland Bolts	18-8 Stainless Steel
4. Stem	ASTM A276-316SS	13. Handle Nut/Screw	300 Series Stainless Steel
5. Seat	Multi-Seal	14. Packing Gland	ASTM A276-316SS
6. Packing	PTFE	15. Gland Plate	300 Series Stainless Steel
7. Stem Bearing	PEEK/PTFE	16. Lever Handle	300 Series Stainless Steel
8. Body Gasket	RPTFE	17. Lock Plate	300 Series Stainless Steel
9. Body Bolts	18-8 Stainless Steel	18. Stops	300 Series Stainless Steel

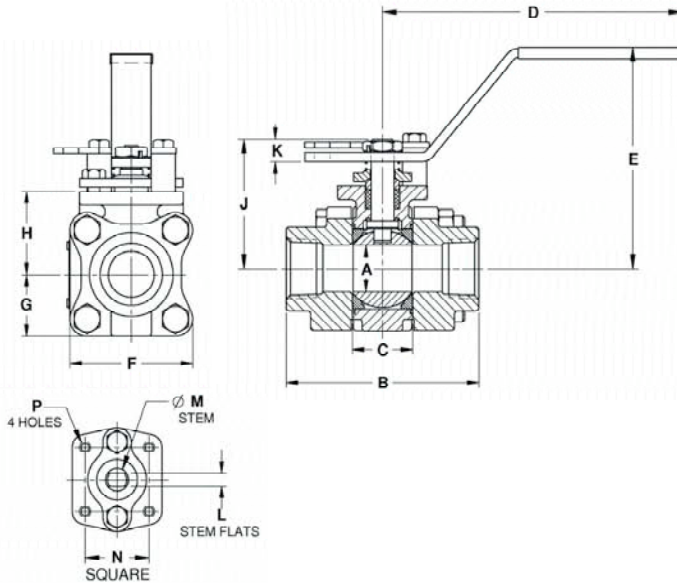

OPTIONS AVAILABLE:

(SUFFIX)	OPTION	SIZES
-04	2-1/4" Stem Extension	3/8" to 2"
-14	Vented Ball (see page J-2)	3/8" to 2"
-15	Round Handle	3/8" to 2"
-49	Assembled Dry	3/8" to 2"
-60	Static Grounding	3/8" to 2"
-63	NPT x Socketweld	3/8" to 2"
-67	Cleaned for Industrial Gases	3/8" to 2"
-69	Drilled & Tapped Purge & Drains	3/8" to 2"
-70	Extended Bonnet	3/8" to 2"
-76	Live Loaded (Lever Operated)	3/8" to 2"
-77	Live Loaded (Actuated)	3/8" to 2"

For Pressure/Temperature Ratings,
Refer to Page M-17, Graph No. 23

CARBON STEEL 3-PIECE FULL PORT BALL VALVE

NUMBER	SIZE	A	B	C	D	E	F	G	H	J	K	L	M	N	P	WT.
83A-142-01	3/8"	.50	2.80	0.89	5.12	3.02	2.02	1.01	1.39	1.97	0.23	0.245	0.375	1.00	10-24	2.3
83A-143-01	1/2"	.50	2.80	0.89	5.12	3.02	2.02	1.01	1.39	1.97	0.23	0.245	0.375	1.00	10-24	2.3
83A-144-01	3/4"	0.75	3.68	1.10	5.53	3.40	2.40	1.20	1.65	2.35	0.24	0.312	0.500	1.392	1/4-20	4.0
83A-145-01	1"	1.00	4.19	1.31	6.53	4.80	2.67	1.34	1.80	2.80	0.48	0.287	0.500	1.392	1/4-20	5.7
83A-146-01	1-1/4"	1.50	4.50	1.97	6.65	4.70	3.84	1.92	2.49	3.89	0.72	0.412	0.625	1.949	5/16-18	14.2
83A-147-01	1-1/2"	1.50	4.98	1.97	6.65	4.70	3.84	1.92	2.49	3.89	0.72	0.412	0.625	1.949	5/16-18	14.4
83A-148-01	2"	2.00	5.86	2.56	8.40	5.47	4.92	2.46	3.17	4.74	0.80	0.477	0.750	1.949	5/16-18	27.6



83A-240 Series

3-Piece Full Port Carbon Steel 1500 CWP Socket-Weld Ball Valve

Standard Compliance - Valve design: MSS SP-110, End Connections: Socket-weld per ASME B16.11, Valve Marking: MSS SP-25, Production Testing: MSS SP-110, NACE MR0175, 2000 edition.

FEATURES

- 3-Piece construction w/ enclosed fasteners
- Full port
- Stainless steel trim & hardware
- Swing-out center section
- Pressure balanced solid ball
- Compression controlled RPTFE gaskets
- Anti-blowout one piece bottom entry stem
- Two-position locking
- Adjustable multi-piece PTFE "V" style packing
- Fully machined ISO 5211 mounting
- Cast bosses on the centersection and end caps for bleed & drain ports
- Vacuum service to 29 in of Hg.

STANDARD MATERIAL LIST

1. Body	ASTM A216-WCB	10. Body Nuts	18-8 Stainless Steel
2. End Caps	ASTM A216-WCB	11. Stop Bolts	18-8 Stainless Steel
3. Ball	ASTM A276-316SS	12. Gland Bolts	18-8 Stainless Steel
4. Stem	ASTM A276-316SS	13. Handle Nut/Screw	300 Series Stainless Steel
5. Seat	Multi-Seal	14. Packing Gland	ASTM A276-316SS
6. Packing	PTFE	15. Gland Plate	300 Series Stainless Steel
7. Stem Bearing	PEEK/PTFE	16. Lever Handle	300 Series Stainless Steel
8. Body Gasket	RPTFE	17. Lock Plate	300 Series Stainless Steel
9. Body Bolts	18-8 Stainless Steel	18. Stops	300 Series Stainless Steel

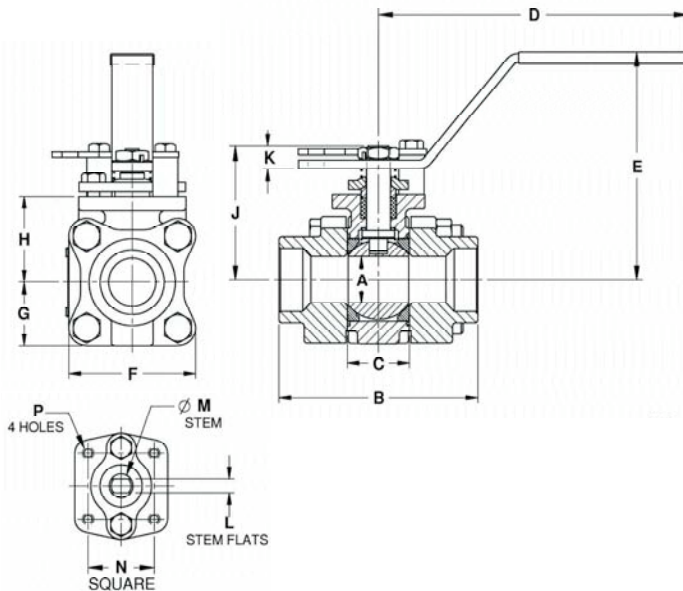

OPTIONS AVAILABLE:

(SUFFIX)	OPTION	SIZES
-04	2-1/4" Stem Extension	3/8" to 2"
-14	Vented Ball (see page J-2)	3/8" to 2"
-15	Round Handle	3/8" to 2"
-49	Assembled Dry	3/8" to 2"
-60	Static Grounding	3/8" to 2"
-67	Cleaned for Industrial Gases	3/8" to 2"
-69	Drilled & Tapped Purge & Drains	3/8" to 2"
-70	Extended Bonnet	3/8" to 2"
-76	Live Loaded (Lever Operated)	3/8" to 2"
-77	Live Loaded (Actuated)	3/8" to 2"

**For Pressure/Temperature Ratings,
Refer to Page M-17, Graph No. 23**

CARBON STEEL 3-PIECE FULL PORT BALL VALVE

NUMBER	SIZE	A	B	C	D	E	F	G	H	J	K	L	M	N	P	WT.
83A-242-01	3/8"	.50	2.80	0.89	5.12	3.02	2.02	1.01	1.39	1.97	0.23	0.245	0.375	1.00	10-24	2.3
83A-243-01	1/2"	.50	2.80	0.89	5.12	3.02	2.02	1.01	1.39	1.97	0.23	0.245	0.375	1.00	10-24	2.3
83A-244-01	3/4"	0.75	3.68	1.10	5.53	3.40	2.40	1.20	1.65	2.35	0.24	0.312	0.500	1.392	1/4-20	4.0
83A-245-01	1"	1.00	4.19	1.31	6.53	4.80	2.67	1.34	1.80	2.80	0.48	0.287	0.500	1.392	1/4-20	5.7
83A-246-01	1-1/4"	1.50	4.50	1.97	6.65	4.70	3.84	1.92	2.49	3.89	0.72	0.412	0.625	1.949	5/16-18	14.2
83A-247-01	1-1/2"	1.50	4.98	1.97	6.65	4.70	3.84	1.92	2.49	3.89	0.72	0.412	0.625	1.949	5/16-18	14.4
83A-248-01	2"	2.00	5.86	2.56	8.40	5.47	4.92	2.46	3.17	4.74	0.80	0.477	0.750	1.949	5/16-18	27.6



83A-540 Series

3-Piece Full Port Carbon Steel 1500 CWP Butt-Weld Ball Valve

Standard Compliance - Valve design: MSS SP-110, End Connections: Butt-weld per ASME B16.25, Valve Marking: MSS SP-25, Production Testing: MSS SP-110, NACE MR0175, 2000 edition.

FEATURES

- 3-Piece construction w/ enclosed fasteners
- Full port
- Stainless steel trim & hardware
- Swing-out center section
- Pressure balanced solid ball
- Compression controlled RPTFE gaskets
- Anti-blowout one piece bottom entry stem
- Two-position locking
- Adjustable multi-piece PTFE "V" style packing
- Fully machined ISO 5211 mounting
- Cast bosses on the centersection and end caps
- Vacuum service to 29 in of Hg.

STANDARD MATERIAL LIST

1. Body	ASTM A216-WCB	10. Body Nuts	18-8 Stainless Steel
2. End Caps	ASTM A216-WCB	11. Stop Bolts	18-8 Stainless Steel
3. Ball	ASTM A276-316SS	12. Gland Bolts	18-8 Stainless Steel
4. Stem	ASTM A276-316SS	13. Handle Nut/Screw	300 Series Stainless Steel
5. Seat	Multi-Seal	14. Packing Gland	ASTM A276-316SS
6. Packing	PTFE	15. Gland Plate	300 Series Stainless Steel
7. Stem Bearing	PEEK/PTFE	16. Lever Handle	300 Series Stainless Steel
8. Body Gasket	RPTFE	17. Lock Plate	300 Series Stainless Steel
9. Body Bolts	18-8 Stainless Steel	18. Stops	300 Series Stainless Steel

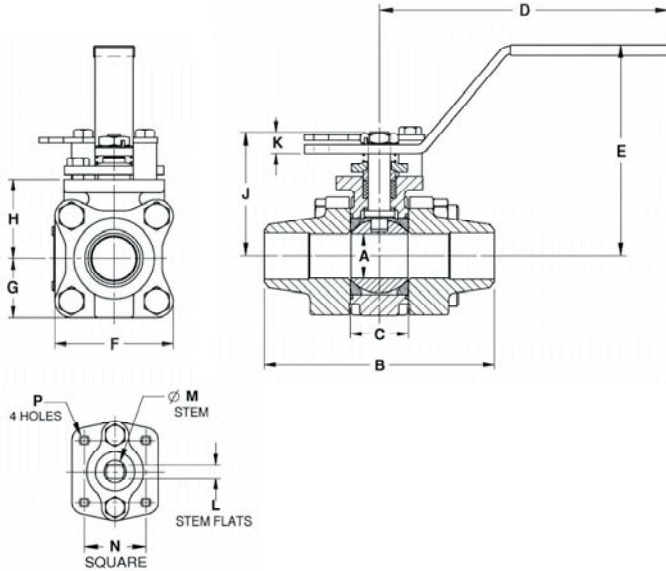

VARIATIONS AVAILABLE:

- 83A-340 - Schedule 5 Butt-weld
- 83A-440 - Schedule 10 Butt-weld
- 83A-640 - Schedule 80 Butt-weld

OPTIONS AVAILABLE:

(SUFFIX)	OPTION	SIZES
-04	2-1/4" Stem Extension	3/8" to 2"
-14	Vented Ball (see page J-2)	3/8" to 2"
-15	Round Handle	3/8" to 2"
-49	Assembled Dry	3/8" to 2"
-60	Static Grounding	3/8" to 2"
-67	Cleaned for Industrial Gases	3/8" to 2"
-69	Drilled & Tapped Purge & Drains	3/8" to 2"
-70	Extended Bonnet	3/8" to 2"
-76	Live Loaded (Lever Operated)	3/8" to 2"
-77	Live Loaded (Actuated)	3/8" to 2"

For Pressure/Temperature Ratings,
Refer to Page M-17, Graph No. 23

CARBON STEEL 3-PIECE FULL PORT BALL VALVE

NUMBER	SIZE	A	B	C	D	E	F	G	H	J	K	L	M	N	P	WT.
83A-542-01	3/8"	.50	3.80	0.89	5.12	3.02	2.02	1.01	1.39	1.97	0.23	0.245	0.375	1.00	10-24	2.3
83A-543-01	1/2"	.50	3.80	0.89	5.12	3.02	2.02	1.01	1.39	1.97	0.23	0.245	0.375	1.00	10-24	2.3
83A-544-01	3/4"	0.75	4.66	1.10	5.53	3.40	2.40	1.20	1.65	2.35	0.24	0.312	0.500	1.392	1/4-20	4.0
83A-545-01	1"	1.00	5.19	1.31	6.53	4.80	2.67	1.34	1.80	2.80	0.48	0.287	0.500	1.392	1/4-20	5.7
83A-546-01	1-1/4"	1.50	5.48	1.97	6.65	4.70	3.84	1.92	2.49	3.89	0.72	0.412	0.625	1.949	5/16-18	14.2
83A-547-01	1-1/2"	1.50	5.96	1.97	6.65	4.70	3.84	1.92	2.49	3.89	0.72	0.412	0.625	1.949	5/16-18	14.4
83A-548-01	2"	2.00	6.84	2.56	8.40	5.47	4.92	2.46	3.17	4.74	0.80	0.477	0.750	1.949	5/16-18	27.6



83B-140 Series

3-Piece Full Port Carbon Steel Class 600 NPT Ball Valve

Standard Compliance - Valve design: ASME B16.34, Class 600, End Connections: NPT per ASME B1.20.1, Valve Marking: ASME B16.34, Production Testing: ASME B16.34, NACE MR0175, 2000 edition.

FEATURES

- 3-Piece construction w/ enclosed fasteners
- Full port
- Stainless steel trim & hardware
- Swing-out center section
- Pressure balanced solid ball
- Compression controlled spiral wound gaskets
- Anti-blowout one piece bottom entry stem
- Statically grounded ball, stem, & body
- Two-position locking
- Adjustable multi-piece PTFE "V" style packing
- Fully machined ISO 5211 mounting
- Cast bosses on the centersection and end caps for bleed & drain ports
- Vacuum service to 29 in of Hg.
- CE mark, 1-1/4" and larger

STANDARD MATERIAL LIST

1. Body	ASTM A216-WCB	10. Body Nuts	ASTM A194-Gr.8
2. End Caps	ASTM A216-WCB	11. Stop Bolts	18-8 Stainless Steel
3. Ball	ASTM A276-316SS	12. Gland Bolts	ASTM A193-Gr.B8
4. Stem	ASTM A276-316SS	13. Handle Nut/Screw	300 Series Stainless Steel
5. Seat	Multi-Seal	14. Packing Gland	ASTM A276-316SS
6. Packing	PTFE	15. Gland Plate	300 Series Stainless Steel
7. Stem Bearing	PEEK/PTFE	16. Lever Handle	300 Series Stainless Steel
8. Body Gasket	PTFE Spiral Wound	17. Lock Plate	300 Series Stainless Steel
9. Body Bolts	ASTM A193-Gr.B8M3	18. Stops	300 Series Stainless Steel
		19. Int. Gmd. Spring	300 Series Stainless Steel
		20. Ext. Gmd. Spring	300 Series Stainless Steel

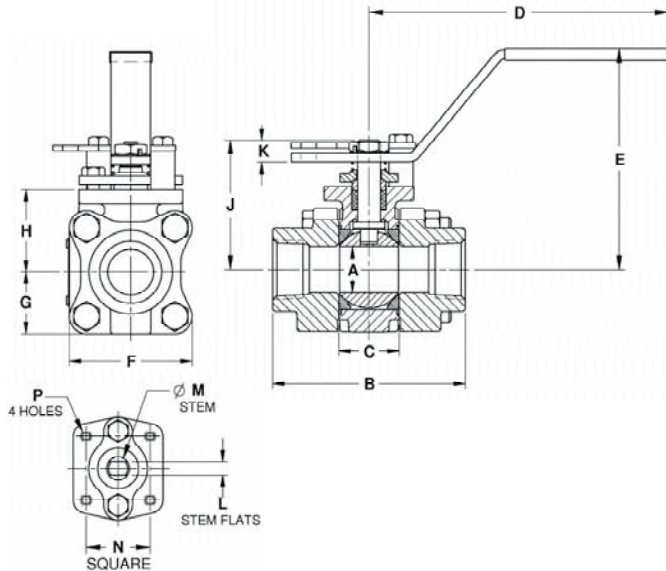

OPTIONS AVAILABLE:

(SUFFIX)	OPTION	SIZES
-04	2-1/4" Stem Extension	3/8" to 2"
-14	Vented Ball (see page J-2)	3/8" to 2"
-15	Round Handle	3/8" to 2"
-21	UHMWPE Seats w/Graphite Seals	3/8" to 2"
-24	Fire Safe - Graphite Packing & Gaskets (API 607, 5th ed., ISO 10497-5)	3/8" to 2"
-49	Assembled Dry	3/8" to 2"
-63	NPT x Socketweld	3/8" to 2"
-67	Cleaned for Industrial Gases	3/8" to 2"
-69	Drilled & Tapped Purge & Drains	3/8" to 2"
-70	Extended Bonnet	3/8" to 2"
-76	Live Loaded (Lever Operated)	3/8" to 2"
-77	Live Loaded (Actuated)	3/8" to 2"

**For Pressure/Temperature Ratings,
Refer to Page M-18, Graph No. 25**

CARBON STEEL 3-PIECE FULL PORT BALL VALVE

NUMBER	SIZE	A	B	C	D	E	F	G	H	J	K	L	M	N	P	WT.
83B-142-01	3/8"	.50	2.80	0.89	5.12	3.02	2.02	1.01	1.39	1.97	0.23	0.245	0.375	1.00	10-24	2.3
83B-143-01	1/2"	.50	2.80	0.89	5.12	3.02	2.02	1.01	1.39	1.97	0.23	0.245	0.375	1.00	10-24	2.3
83B-144-01	3/4"	0.75	3.68	1.10	5.53	3.40	2.40	1.20	1.65	2.35	0.24	0.312	0.500	1.392	1/4-20	4.0
83B-145-01	1"	1.00	4.19	1.31	6.53	4.80	2.67	1.34	1.80	2.80	0.48	0.287	0.500	1.392	1/4-20	5.7
83B-146-01	1-1/4"	1.50	4.50	1.97	6.65	4.70	3.84	1.92	2.49	3.89	0.72	0.412	0.625	1.949	5/16-18	14.2
83B-147-01	1-1/2"	1.50	4.98	1.97	6.65	4.70	3.84	1.92	2.49	3.89	0.72	0.412	0.625	1.949	5/16-18	14.4
83B-148-01	2"	2.00	5.86	2.56	8.40	5.47	4.92	2.46	3.17	4.74	0.80	0.477	0.750	1.949	5/16-18	27.6



83B-240 Series

3-Piece Full Port Carbon Steel Class 600 Socket-Weld Ball Valve

Standard Compliance - Valve design: ASME B16.34, Class 600, End Connections: Socket-weld per ASME B16.11, Valve Marking: ASME B16.34, Production Testing: ASME B16.34, NACE MR0175, 2000 edition.

FEATURES

- 3-Piece construction w/ enclosed fasteners
- Full port
- Stainless steel trim & hardware
- Swing-out center section
- Pressure balanced solid ball
- Compression controlled spiral wound gaskets
- Anti-blowout one piece bottom entry stem
- Statically grounded ball, stem, & body
- Two-position locking
- Adjustable multi-piece PTFE "V" style packing
- Fully machined ISO 5211 mounting
- Cast bosses on the centersection and end caps for bleed & drain ports
- Vacuum service to 29 in of Hg.
- CE mark, 1-1/4" and larger

STANDARD MATERIAL LIST

1. Body	ASTM A216-WCB	10. Body Nuts	ASTM A194-Gr.8
2. End Caps	ASTM A216-WCB	11. Stop Bolts	18-8 Stainless Steel
3. Ball	ASTM A276-316SS	12. Gland Bolts	ASTM A193-Gr.B8
4. Stem	ASTM A276-316SS	13. Handle Nut/Screw	300 Series Stainless Steel
5. Seat	Multi-Seal	14. Packing Gland	ASTM A276-316SS
6. Packing	PTFE	15. Gland Plate	300 Series Stainless Steel
7. Stem Bearing	PEEK/PTFE	16. Lever Handle	300 Series Stainless Steel
8. Body Gasket	PTFE Spiral Wound	17. Lock Plate	300 Series Stainless Steel
9. Body Bolts	ASTM A193-Gr.B8M3	18. Stops	300 Series Stainless Steel
		19. Int. Gmd. Spring	300 Series Stainless Steel
		20. Ext. Gmd. Spring	300 Series Stainless Steel

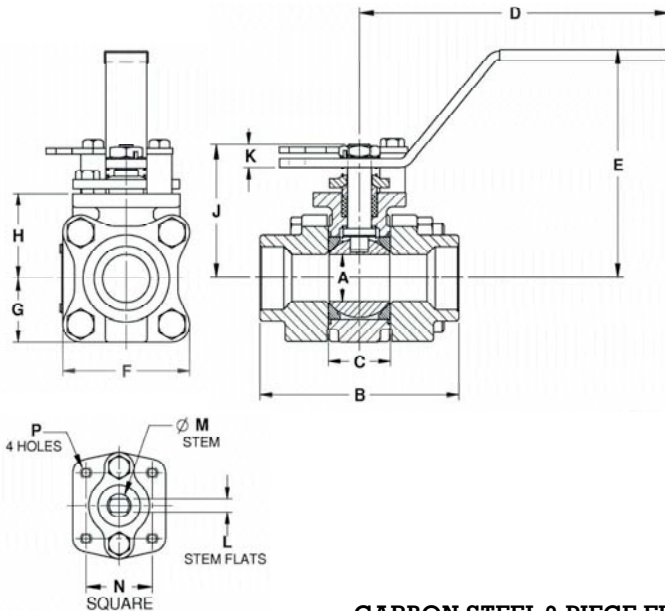

OPTIONS AVAILABLE:

(SUFFIX)	OPTION	SIZES
-04	2-1/4" Stem Extension	3/8" to 2"
-14	Vented Ball (see page J-2)	3/8" to 2"
-15	Round Handle	3/8" to 2"
-21	UHMWPE Seats w/Graphite Seals	3/8" to 2"
-24	Fire Safe - Graphite Packing & Gaskets (API 607, 5th ed., ISO 10497-5)	3/8" to 2"
-49	Assembled Dry	3/8" to 2"
-67	Cleaned for Industrial Gases	3/8" to 2"
-69	Drilled & Tapped Purge & Drains	3/8" to 2"
-70	Extended Bonnet	3/8" to 2"
-76	Live Loaded (Lever Operated)	3/8" to 2"
-77	Live Loaded (Actuated)	3/8" to 2"

**For Pressure/Temperature Ratings,
Refer to Page M-18, Graph No. 25**

CARBON STEEL 3-PIECE FULL PORT BALL VALVE

NUMBER	SIZE	A	B	C	D	E	F	G	H	J	K	L	M	N	P	WT.
83B-242-01	3/8"	.50	2.80	0.89	5.12	3.02	2.02	1.01	1.39	1.97	0.23	0.245	0.375	1.00	10-24	2.3
83B-243-01	1/2"	.50	2.80	0.89	5.12	3.02	2.02	1.01	1.39	1.97	0.23	0.245	0.375	1.00	10-24	2.3
83B-244-01	3/4"	0.75	3.68	1.10	5.53	3.40	2.40	1.20	1.65	2.35	0.24	0.312	0.500	1.392	1/4-20	4.0
83B-245-01	1"	1.00	4.19	1.31	6.53	4.80	2.67	1.34	1.80	2.80	0.48	0.287	0.500	1.392	1/4-20	5.7
83B-246-01	1-1/4"	1.50	4.50	1.97	6.65	4.70	3.84	1.92	2.49	3.89	0.72	0.412	0.625	1.949	5/16-18	14.2
83B-247-01	1-1/2"	1.50	4.98	1.97	6.65	4.70	3.84	1.92	2.49	3.89	0.72	0.412	0.625	1.949	5/16-18	14.4
83B-248-01	2"	2.00	5.86	2.56	8.40	5.47	4.92	2.46	3.17	4.74	0.80	0.477	0.750	1.949	5/16-18	27.6



83B-540 Series

3-Piece Full Port Carbon Steel Class 600 Butt-Weld Ball Valve

Standard Compliance - Valve design: ASME B16.34, Class 600, End Connections: Butt-weld per ASME B16.25, Valve Marking: ASME B16.34, Production Testing: ASME B16.34, NACE MR0175, 2000 edition.

FEATURES

- 3-Piece construction w/ enclosed fasteners
- Full port
- Stainless steel trim & hardware
- Swing-out center section
- Pressure balanced solid ball
- Compression controlled spiral wound gaskets
- Anti-blowout one piece bottom entry stem
- Statically grounded ball, stem, & body
- Two-position locking
- Adjustable multi-piece PTFE "V" style packing
- Fully machined ISO 5211 mounting
- Cast bosses on the centersection and end caps for bleed & drain ports
- Vacuum service to 29 in. of Hg.
- CE mark, 1-1/4" and larger

STANDARD MATERIAL LIST

- | | |
|-----------------|-------------------|
| 1. Body | ASTM A216-WCB |
| 2. End Caps | ASTM A216-WCB |
| 3. Ball | ASTM A276-316SS |
| 4. Stem | ASTM A276-316SS |
| 5. Seat | Multi-Seal |
| 6. Packing | PTFE |
| 7. Stem Bearing | PEEK/PTFE |
| 8. Body Gasket | PTFE Spiral Wound |
| 9. Body Bolts | ASTM A193-Gr.B8M3 |

- | | |
|----------------------|----------------------------|
| 10. Body Nuts | ASTM A194-Gr.8 |
| 11. Stop Bolts | 18-8 Stainless Steel |
| 12. Gland Bolts | ASTM A193-Gr.B8 |
| 13. Handle Nut/Screw | 300 Series Stainless Steel |
| 14. Packing Gland | ASTM A276-316SS |
| 15. Gland Plate | 300 Series Stainless Steel |
| 16. Lever Handle | 300 Series Stainless Steel |
| 17. Lock Plate | 300 Series Stainless Steel |
| 18. Stops | 300 Series Stainless Steel |
| 19. Int. Gmd. Spring | 300 Series Stainless Steel |
| 20. Ext. Gmd. Spring | 300 Series Stainless Steel |

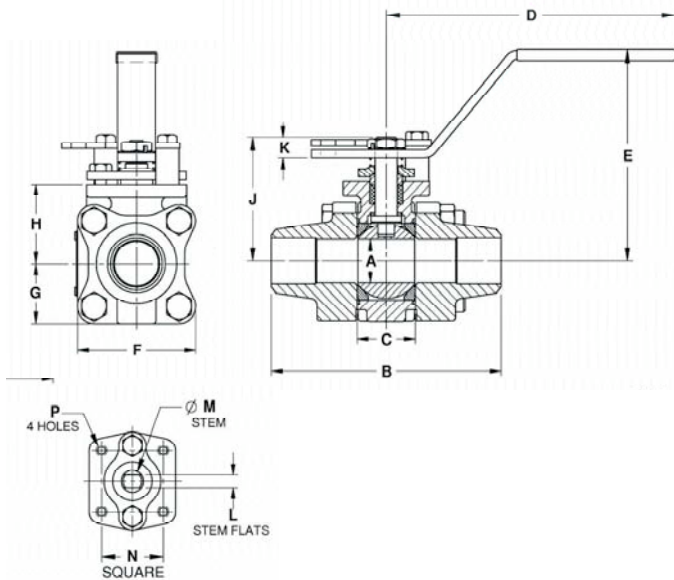

VARIATIONS AVAILABLE:

- 83B-340 - Schedule 5 Butt-weld
- 83B-440 - Schedule 10 Butt-weld
- 83B-640 - Schedule 80 Butt-weld

OPTIONS AVAILABLE:

(SUFFIX)	OPTION	SIZES
-04-	2-1/4" Stem Extension	3/8" to 2"
-14-	Vented Ball (see page J-2)	3/8" to 2"
-15-	Round Handle	3/8" to 2"
-21-	UHMWPE Seats w/Graphite Seals	3/8" to 2"
-24-	Fire Safe - Graphite Packing & Gaskets (API607, 5th ed., ISO 10497-5)	3/8" to 2"
-49-	Assembled Dry	3/8" to 2"
-67-	Cleaned for Industrial Gases	3/8" to 2"
-69-	Drilled & Tapped Purge & Drains	3/8" to 2"
-70-	Extended Bonnet	3/8" to 2"
-76-	Live Loaded (Lever Operated)	3/8" to 2"
-77-	Live Loaded (Actuated)	3/8" to 2"

**For Pressure/Temperature Ratings,
Refer to Page M-18, Graph No. 25**

CARBON STEEL 3-PIECE FULL PORT BALL VALVE

NUMBER	SIZE	A	B	C	D	E	F	G	H	J	K	L	M	N	P	WT.
83B-542-01	3/8"	.50	3.80	0.89	5.12	3.02	2.02	1.01	1.39	1.97	0.23	0.245	0.375	1.00	10-24	2.3
83B-543-01	1/2"	.50	3.80	0.89	5.12	3.02	2.02	1.01	1.39	1.97	0.23	0.245	0.375	1.00	10-24	2.3
83B-544-01	3/4"	0.75	4.66	1.10	5.53	3.40	2.40	1.20	1.65	2.35	0.24	0.312	0.500	1.392	1/4-20	4.0
83B-545-01	1"	1.00	5.19	1.31	6.53	4.80	2.67	1.34	1.80	2.80	0.48	0.287	0.500	1.392	1/4-20	5.7
83B-546-01	1-1/4"	1.50	5.48	1.97	6.65	4.70	3.84	1.92	2.49	3.89	0.72	0.412	0.625	1.949	5/16-18	14.2
83B-547-01	1-1/2"	1.50	5.96	1.97	6.65	4.70	3.84	1.92	2.49	3.89	0.72	0.412	0.625	1.949	5/16-18	14.4
83B-548-01	2"	2.00	6.84	2.56	8.40	5.47	4.92	2.46	3.17	4.74	0.80	0.477	0.750	1.949	5/16-18	27.6



86A-100 Series

3-Piece Full Port Stainless Steel 1500 CWP NPT Ball Valve

**Standard Compliance - Valve design: MSS SP-110, End Connections: NPT per ASME B1.20.1,
Valve Marking: MSS SP-25, Production Testing: MSS SP-110, NACE MR0175, 2000 edition.**

FEATURES

- 3-Piece construction w/ enclosed fasteners
- Full port
- Stainless steel trim & hardware
- Swing-out center section
- Pressure balanced solid ball
- Compression controlled RPTFE gaskets
- Anti-blowout one piece bottom entry stem
- Two-position locking
- Adjustable multi-piece PTFE "V" style packing
- Fully machined ISO 5211 mounting
- Cast bosses on the centersection and end caps for bleed & drain ports
- Vacuum service to 29 in of Hg.

STANDARD MATERIAL LIST

1. Body	ASTM A351-CF8M	10. Body Nuts	18-8 Stainless Steel
2. End Caps	ASTM A351-CF3M	11. Stop Bolts	18-8 Stainless Steel
3. Ball	ASTM A276-316SS	12. Gland Bolts	18-8 Stainless Steel
4. Stem	ASTM A276-316SS	13. Handle Nut/Screw	300 Series Stainless Steel
5. Seat	Multi-Seal	14. Packing Gland	ASTM A276-316SS
6. Packing	PTFE	15. Gland Plate	300 Series Stainless Steel
7. Stem Bearing	PEEK/PTFE	16. Lever Handle	300 Series Stainless Steel
8. Body Gasket	RPTFE	17. Lock Plate	300 Series Stainless Steel
9. Body Bolts	18-8 Stainless Steel	18. Stops	300 Series Stainless Steel

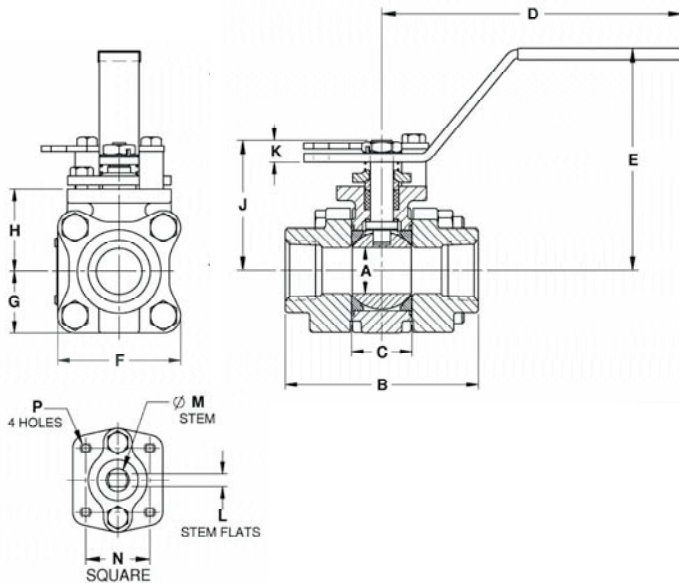

OPTIONS AVAILABLE:

(SUFFIX)	OPTION	SIZES
-04	2-1/4" Stem Extension	3/8" to 2"
-14	Vented Ball (see page J-2)	3/8" to 2"
-15	Round Handle	3/8" to 2"
-49	Assembled Dry	3/8" to 2"
-57	Cleaned for Oxygen Service	3/8" to 2"
-60	Static Grounding	3/8" to 2"
-63	NPT x Socketweld	3/8" to 2"
-69	Drilled & Tapped Purge & Drains	3/8" to 2"
-70	Extended Bonnet	3/8" to 2"
-76	Live Loaded (Lever Operated)	3/8" to 2"
-77	Live Loaded (Actuated)	3/8" to 2"

**For Pressure/Temperature Ratings,
Refer to Page M-17, Graph No. 24**

STAINLESS STEEL 3-PIECE FULL PORT BALL VALVE

NUMBER	SIZE	A	B	C	D	E	F	G	H	J	K	L	M	N	P	WT.
86A-102-01	3/8"	.50	2.80	0.89	5.12	3.02	2.02	1.01	1.39	1.97	0.23	0.245	0.375	1.00	10-24	2.3
86A-103-01	1/2"	.50	2.80	0.89	5.12	3.02	2.02	1.01	1.39	1.97	0.23	0.245	0.375	1.00	10-24	2.3
86A-104-01	3/4"	0.75	3.68	1.10	5.53	3.40	2.40	1.20	1.65	2.35	0.24	0.312	0.500	1.392	1/4-20	4.0
86A-105-01	1"	1.00	4.19	1.31	6.53	4.80	2.67	1.34	1.80	2.80	0.48	0.287	0.500	1.392	1/4-20	5.7
86A-106-01	1-1/4"	1.50	4.50	1.97	6.65	4.70	3.84	1.92	2.49	3.89	0.72	0.412	0.625	1.949	5/16-18	14.2
86A-107-01	1-1/2"	1.50	4.98	1.97	6.65	4.70	3.84	1.92	2.49	3.89	0.72	0.412	0.625	1.949	5/16-18	14.4
86A-108-01	2"	2.00	5.86	2.56	8.40	5.47	4.92	2.46	3.17	4.74	0.80	0.477	0.750	1.949	5/16-18	27.6



86A-200 Series

3-Piece Full Port Stainless Steel 1500 CWP Socket-Weld Ball Valve

Standard Compliance - Valve design: MSS SP-110, **End Connections:** Socket-weld per ASME B16.11, **Valve Marking:** MSS SP-25, **Production Testing:** MSS SP-110, NACE MR0175, 2000 edition.

FEATURES

- 3-Piece construction w/ enclosed fasteners
- Full port
- Stainless steel trim & hardware
- Swing-out center section
- Pressure balanced solid ball
- Compression controlled RPTFE gaskets
- Anti-blowout one piece bottom entry stem
- Two-position locking
- Adjustable multi-piece PTFE "V" style packing
- Fully machined ISO 5211 mounting
- Cast bosses on the centersection and end caps for bleed & drain ports
- Vacuum service to 29 in of Hg.

STANDARD MATERIAL LIST

1. Body	ASTM A351-CF8M	10. Body Nuts	18-8 Stainless Steel
2. End Caps	ASTM A351-CF3M	11. Stop Bolts	18-8 Stainless Steel
3. Ball	ASTM A276-316SS	12. Gland Bolts	18-8 Stainless Steel
4. Stem	ASTM A276-316SS	13. Handle Nut/Screw	300 Series Stainless Steel
5. Seat	Multi-Seal	14. Packing Gland	ASTM A276-316SS
6. Packing	PTFE	15. Gland Plate	300 Series Stainless Steel
7. Stem Bearing	PEEK/PTFE	16. Lever Handle	300 Series Stainless Steel
8. Body Gasket	RPTFE	17. Lock Plate	300 Series Stainless Steel
9. Body Bolts	18-8 Stainless Steel	18. Stops	300 Series Stainless Steel

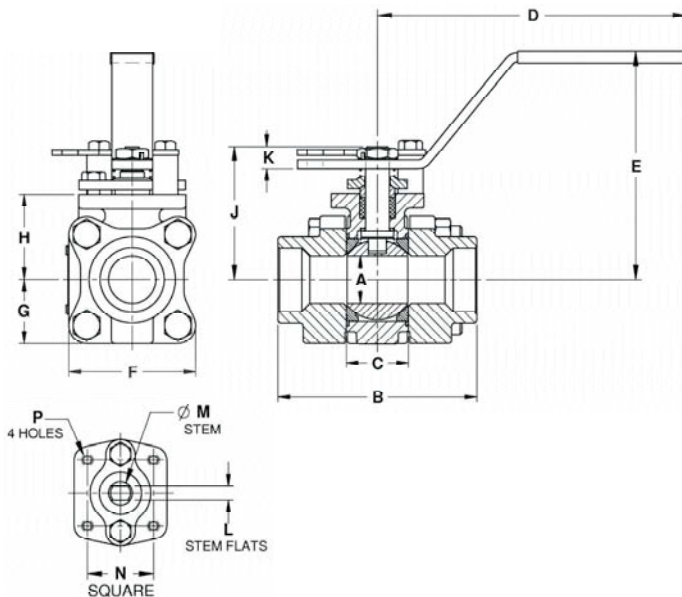

OPTIONS AVAILABLE:

(SUFFIX)	OPTION	SIZES
-04-	2-1/4" Stem Extension	3/8" to 2"
-14-	Vented Ball (see page J-2)	3/8" to 2"
-15-	Round Handle	3/8" to 2"
-49-	Assembled Dry	3/8" to 2"
-57-	Cleaned for Oxygen Service	3/8" to 2"
-60-	Static Grounding	3/8" to 2"
-69-	Drilled & Tapped Purge & Drains	3/8" to 2"
-70-	Extended Bonnet	3/8" to 2"
-76-	Live Loaded (Lever Operated)	3/8" to 2"
-77-	Live Loaded (Actuated)	3/8" to 2"

**For Pressure/Temperature Ratings,
Refer to Page M-17, Graph No. 24**

STAINLESS STEEL 3-PIECE FULL PORT BALL VALVE

NUMBER	SIZE	A	B	C	D	E	F	G	H	J	K	L	M	N	P	WT.
86A-202-01	3/8"	.50	2.80	0.89	5.12	3.02	2.02	1.01	1.39	1.97	0.23	0.245	0.375	1.00	10-24	2.3
86A-203-01	1/2"	.50	2.80	0.89	5.12	3.02	2.02	1.01	1.39	1.97	0.23	0.245	0.375	1.00	10-24	2.3
86A-204-01	3/4"	0.75	3.68	1.10	5.53	3.40	2.40	1.20	1.65	2.35	0.24	0.312	0.500	1.392	1/4-20	4.0
86A-205-01	1"	1.00	4.19	1.31	6.53	4.80	2.67	1.34	1.80	2.80	0.48	0.287	0.500	1.392	1/4-20	5.7
86A-206-01	1-1/4"	1.50	4.50	1.97	6.65	4.70	3.84	1.92	2.49	3.89	0.72	0.412	0.625	1.949	5/16-18	14.2
86A-207-01	1-1/2"	1.50	4.98	1.97	6.65	4.70	3.84	1.92	2.49	3.89	0.72	0.412	0.625	1.949	5/16-18	14.4
86A-208-01	2"	2.00	5.86	2.56	8.40	5.47	4.92	2.46	3.17	4.74	0.80	0.477	0.750	1.949	5/16-18	27.6



86A-500 Series

3-Piece Full Port Stainless Steel 1500 CWP Butt-Weld Ball Valve

Standard Compliance - Valve design: MSS SP-110, End Connections: Butt-weld per ASME B16.25, Valve Marking: MSS SP-25, Production Testing: MSS SP-110, NACE MR0175, 2000 edition.

FEATURES

- 3-Piece construction w/ enclosed fasteners
- Full port
- Stainless steel trim & hardware
- Swing-out center section
- Pressure balanced solid ball
- Compression controlled RPTFE gaskets
- Anti-blowout one piece bottom entry stem
- Two-position locking
- Adjustable multi-piece PTFE "V" style packing
- Fully machined ISO 5211 mounting
- Cast bosses on the centersection and end caps for bleed & drain ports
- Vacuum service to 29 in of Hg.

STANDARD MATERIAL LIST

1. Body	ASTM A351-CF8M	10. Body Nuts	18-8 Stainless Steel
2. End Caps	ASTM A351-CF3M	11. Stop Bolts	18-8 Stainless Steel
3. Ball	ASTM A276-316SS	12. Gland Bolts	18-8 Stainless Steel
4. Stem	ASTM A276-316SS	13. Handle Nut/Screw	300 Series Stainless Steel
5. Seat	Multi-Seal	14. Packing Gland	ASTM A276-316SS
6. Packing	PTFE	15. Gland Plate	300 Series Stainless Steel
7. Stem Bearing	PEEK/PTFE	16. Lever Handle	300 Series Stainless Steel
8. Body Gasket	RPTFE	17. Lock Plate	300 Series Stainless Steel
9. Body Bolts	18-8 Stainless Steel	18. Stops	300 Series Stainless Steel

VARIATIONS AVAILABLE:

- 86A-300 - Schedule 5 Butt-weld
- 86A-400 - Schedule 10 Butt-weld
- 86A-600 - Schedule 80 Butt-weld

OPTIONS AVAILABLE:

(SUFFIX)	OPTION	SIZES
-04	2-1/4" Stem Extension	3/8" to 2"
-14	Vented Ball (see page J-2)	3/8" to 2"
-15	Round Handle	3/8" to 2"
-49	Assembled Dry	3/8" to 2"
-57	Cleaned for Oxygen Service	3/8" to 2"
-60	Static Grounding	3/8" to 2"
-69	Drilled & Tapped Purge & Drains	3/8" to 2"
-70	Extended Bonnet	3/8" to 2"
-76	Live Loaded (Lever Operated)	3/8" to 2"
-77	Live Loaded (Actuated)	3/8" to 2"

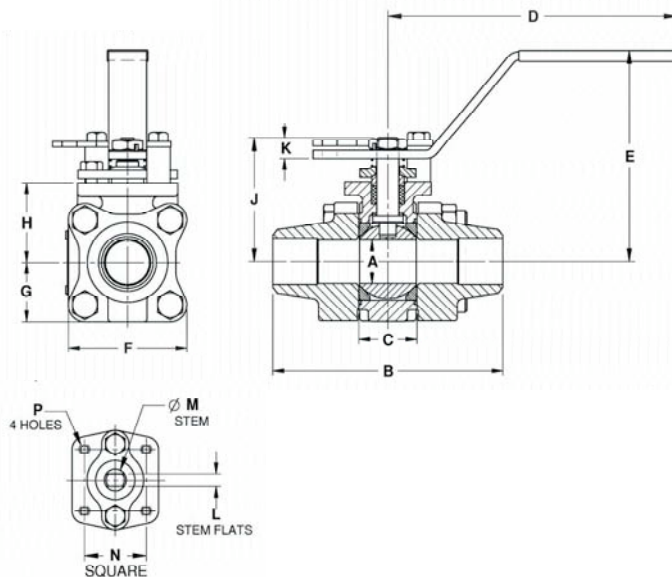

For Pressure/Temperature Ratings,
Refer to Page M-17, Graph No. 24

STAINLESS STEEL 3-PIECE FULL PORT BALL VALVE

NUMBER	SIZE	A	B	C	D	E	F	G	H	J	K	L	M	N	P	WT.
86A-502-01	3/8"	.50	3.80	0.89	5.12	3.02	2.02	1.01	1.39	1.97	0.23	0.245	0.375	1.00	10-24	2.3
86A-503-01	1/2"	.50	3.80	0.89	5.12	3.02	2.02	1.01	1.39	1.97	0.23	0.245	0.375	1.00	10-24	2.3
86A-504-01	3/4"	0.75	4.66	1.10	5.53	3.40	2.40	1.20	1.65	2.35	0.24	0.312	0.500	1.392	1/4-20	4.0
86A-505-01	1"	1.00	5.19	1.31	6.53	4.80	2.67	1.34	1.80	2.80	0.48	0.287	0.500	1.392	1/4-20	5.7
86A-506-01	1-1/4"	1.50	5.48	1.97	6.65	4.70	3.84	1.92	2.49	3.89	0.72	0.412	0.625	1.949	5/16-18	14.2
86A-507-01	1-1/2"	1.50	5.96	1.97	6.65	4.70	3.84	1.92	2.49	3.89	0.72	0.412	0.625	1.949	5/16-18	14.4
86A-508-01	2"	2.00	6.84	2.56	8.40	5.47	4.92	2.46	3.17	4.74	0.80	0.477	0.750	1.949	5/16-18	27.6



86B-100 Series

3-Piece Full Port Stainless Steel Class 600 NPT Ball Valve

Standard Compliance - Valve design: ASME B16.34, Class 600, End Connections: NPT per ASME B1.20.1, Valve Marking: ASME B16.34, Production Testing: ASME B16.34, NACE MR0175, 2000 edition.

FEATURES

- 3-Piece construction w/ enclosed fasteners
- Full port
- Stainless steel trim & hardware
- Swing-out center section
- Pressure balanced solid ball
- Compression controlled spiral wound gaskets
- Anti-blowout one piece bottom entry stem
- Statically grounded ball, stem, & body
- Two-position locking
- Adjustable multi-piece PTFE "V" style packing
- Fully machined ISO 5211 mounting
- Cast bosses on the center section and end caps for bleed & drain ports
- Vacuum service to 29 in of Hg.
- CE mark, 1-1/4" and larger

STANDARD MATERIAL LIST

1. Body	ASTM A351-CF8M	10. Body Nuts	ASTM A194-Gr.8
2. End Caps	ASTM A351-CF3M	11. Stop Bolts	18-8 Stainless Steel
3. Ball	ASTM A276-316SS	12. Gland Bolts	ASTM A193-Gr.B8
4. Stem	ASTM A276-316SS	13. Handle Nut/Screw	300 Series Stainless Steel
5. Seat	Multi-Seal	14. Packing Gland	ASTM A276-316SS
6. Packing	PTFE	15. Gland Plate	300 Series Stainless Steel
7. Stem Bearing	PEEK/PTFE	16. Lever Handle	300 Series Stainless Steel
8. Body Gasket	PTFE Spiral Wound	17. Lock Plate	300 Series Stainless Steel
9. Body Bolts	ASTM A193-Gr.B8M3	18. Stops	300 Series Stainless Steel
		19. Int. Gmd. Spring	300 Series Stainless Steel
		20. Ext. Gmd. Spring	300 Series Stainless Steel

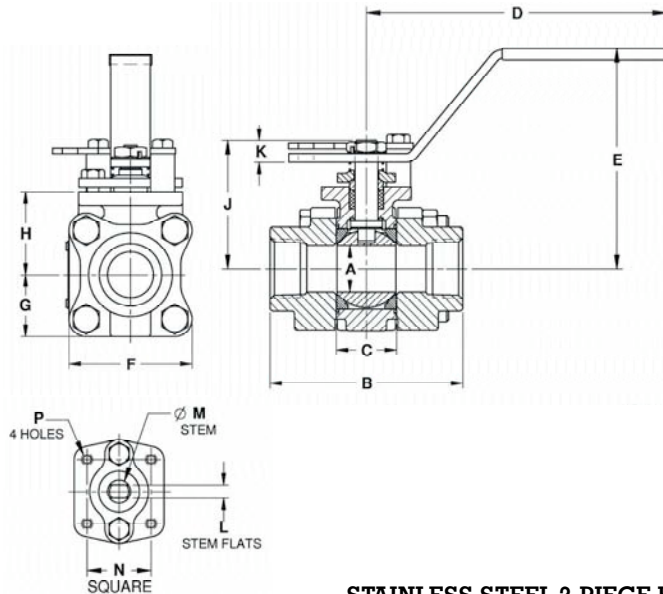

OPTIONS AVAILABLE:

(SUFFIX)	OPTION	SIZES
-04-	2-1/4" Stem Extension	3/8" to 2"
-14-	Vented Ball (see page J-2)	3/8" to 2"
-15-	Round Handle	3/8" to 2"
-21-	UHMWPE Seats w/Graphite Seals	3/8" to 2"
-24-	Fire Safe - Graphite Packing & Gaskets (API 607, 5th ed., ISO 10497-5)	3/8" to 2"
-49-	Assembled Dry	3/8" to 2"
-57-	Cleaned for Oxygen Service	3/8" to 2"
-63-	NPT x Socketweld	3/8" to 2"
-69-	Drilled & Tapped Purge & Drains	3/8" to 2"
-70-	Extended Bonnet	3/8" to 2"
-76-	Live Loaded (Lever Operated)	3/8" to 2"
-77-	Live Loaded (Actuated)	3/8" to 2"

For Pressure/Temperature Ratings,
Refer to Page M-18, Graph No. 26

STAINLESS STEEL 3-PIECE FULL PORT BALL VALVE

NUMBER	SIZE	A	B	C	D	E	F	G	H	J	K	L	M	N	P	WT.
86B-102-01	3/8"	.50	2.80	0.89	5.12	3.02	2.02	1.01	1.39	1.97	0.23	0.245	0.375	1.00	10-24	2.3
86B-103-01	1/2"	.50	2.80	0.89	5.12	3.02	2.02	1.01	1.39	1.97	0.23	0.245	0.375	1.00	10-24	2.3
86B-104-01	3/4"	0.75	3.68	1.10	5.53	3.40	2.40	1.20	1.65	2.35	0.24	0.312	0.500	1.392	1/4-20	4.0
86B-105-01	1"	1.00	4.19	1.31	6.53	4.80	2.67	1.34	1.80	2.80	0.48	0.287	0.500	1.392	1/4-20	5.7
86B-106-01	1-1/4"	1.50	4.50	1.97	6.65	4.70	3.84	1.92	2.49	3.89	0.72	0.412	0.625	1.949	5/16-18	14.2
86B-107-01	1-1/2"	1.50	4.98	1.97	6.65	4.70	3.84	1.92	2.49	3.89	0.72	0.412	0.625	1.949	5/16-18	14.4
86B-108-01	2"	2.00	5.86	2.56	8.40	5.47	4.92	2.46	3.17	4.74	0.80	0.477	0.750	1.949	5/16-18	27.6



86B-200 Series

3-Piece Full Port Stainless Steel Class 600 Socket-Weld Ball Valve

Standard Compliance - Valve design: ASME B16.34, Class 600, End Connections: Socket-weld per ASME B16.11, Valve Marking: ASME B16.34, Production Testing: ASME B16.34, NACE MR0175, 2000 edition.

FEATURES

- 3-Piece construction w/ enclosed fasteners
- Full port
- Stainless steel trim & hardware
- Swing-out center section
- Pressure balanced solid ball
- Compression controlled spiral wound gaskets
- Anti-blowout one piece bottom entry stem
- Statically grounded ball, stem, & body
- Two-position locking
- Adjustable multi-piece PTFE "V" style packing
- Fully machined ISO 5211 mounting
- Cast bosses on the center section and end caps for bleed & drain ports
- Vacuum service to 29 in of Hg.
- CE mark, 1-1/4" and larger

STANDARD MATERIAL LIST

1. Body	ASTM A351-CF8M	10. Body Nuts	ASTM A194-Gr.8
2. End Caps	ASTM A351-CF3M	11. Stop Bolts	18-8 Stainless Steel
3. Ball	ASTM A276-316SS	12. Gland Bolts	ASTM A193-Gr.B8
4. Stem	ASTM A276-316SS	13. Handle Nut/Screw	300 Series Stainless Steel
5. Seat	Multi-Seal	14. Packing Gland	ASTM A276-316SS
6. Packing	PTFE	15. Gland Plate	300 Series Stainless Steel
7. Stem Bearing	PEEK/PTFE	16. Lever Handle	300 Series Stainless Steel
8. Body Gasket	PTFE Spiral Wound	17. Lock Plate	300 Series Stainless Steel
9. Body Bolts	ASTM A193-Gr.B8M3	18. Stops	300 Series Stainless Steel
		19. Int. Gmd. Spring	300 Series Stainless Steel
		20. Ext. Gmd. Spring	300 Series Stainless Steel

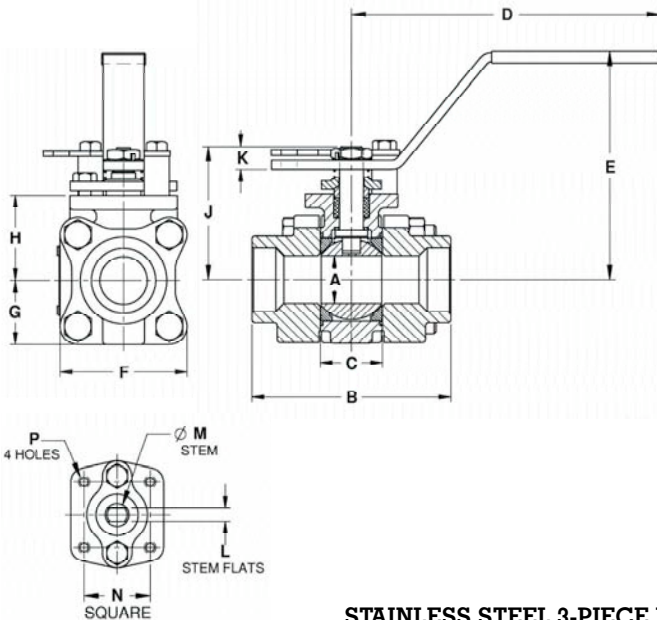

OPTIONS AVAILABLE:

(SUFFIX)	OPTION	SIZES
-04-	2-1/4" Stem Extension	3/8" to 2"
-14-	Vented Ball (see page J-2)	3/8" to 2"
-15-	Round Handle	3/8" to 2"
-21-	UHMWPE Seats w/Graphite Seals	3/8" to 2"
-24-	Fire Safe - Graphite Packing & Gaskets (API 607, 5th ed., ISO 10497-5)	3/8" to 2"
-49-	Assembled Dry	3/8" to 2"
-57-	Cleaned for Oxygen Service	3/8" to 2"
-69-	Drilled & Tapped Purge & Drains	3/8" to 2"
-70-	Extended Bonnet	3/8" to 2"
-76-	Live Loaded (Lever Operated)	3/8" to 2"
-77-	Live Loaded (Actuated)	3/8" to 2"

For Pressure/Temperature Ratings,
Refer to Page M-18, Graph No. 26

STAINLESS STEEL 3-PIECE FULL PORT BALL VALVE

NUMBER	SIZE	A	B	C	D	E	F	G	H	J	K	L	M	N	P	WT.
86B-202-01	3/8"	.50	2.80	0.89	5.12	3.02	2.02	1.01	1.39	1.97	0.23	0.245	0.375	1.00	10-24	2.3
86B-203-01	1/2"	.50	2.80	0.89	5.12	3.02	2.02	1.01	1.39	1.97	0.23	0.245	0.375	1.00	10-24	2.3
86B-204-01	3/4"	0.75	3.68	1.10	5.53	3.40	2.40	1.20	1.65	2.35	0.24	0.312	0.500	1.392	1/4-20	4.0
86B-205-01	1"	1.00	4.19	1.31	6.53	4.80	2.67	1.34	1.80	2.80	0.48	0.287	0.500	1.392	1/4-20	5.7
86B-206-01	1-1/4"	1.50	4.50	1.97	6.65	4.70	3.84	1.92	2.49	3.89	0.72	0.412	0.625	1.949	5/16-18	14.2
86B-207-01	1-1/2"	1.50	4.98	1.97	6.65	4.70	3.84	1.92	2.49	3.89	0.72	0.412	0.625	1.949	5/16-18	14.4
86B-208-01	2"	2.00	5.86	2.56	8.40	5.47	4.92	2.46	3.17	4.74	0.80	0.477	0.750	1.949	5/16-18	27.6



86B-500 Series

3-Piece Full Port Stainless Steel Class 600

Butt-Weld Ball Valve

Standard Compliance - Valve design: ASME B16.34, Class 600, End Connections: Butt-weld per ASME B16.25, Valve Marking: ASME B16.34, Production Testing: ASME B16.34, NACE MR0175, 2000 edition.

FEATURES

- 3-Piece construction w/ enclosed fasteners
- Full port
- Stainless steel trim & hardware
- Swing-out center section
- Pressure balanced solid ball
- Compression controlled spiral wound gaskets
- Anti-blowout one piece bottom entry stem
- Statically grounded ball, stem, & body
- Two-position locking
- Adjustable multi-piece PTFE "V" style packing
- Fully machined ISO 5211 mounting
- Cast bosses on the centersection and end caps for bleed & drain ports
- Vacuum service to 29 in of Hg.
- CE mark, 1-1/4" and larger

STANDARD MATERIAL LIST

1. Body	ASTM A351-CF8M	10. Body Nuts	ASTM A194-Gr.8
2. End Caps	ASTM A351-CF3M	11. Stop Bolts	18-8 Stainless Steel
3. Ball	ASTM A276-316SS	12. Gland Bolts	ASTM A193-Gr.B8
4. Stem	ASTM A276-316SS	13. Handle Nut/Screw	300 Series Stainless Steel
5. Seat	Multi-Seal	14. Packing Gland	ASTM A276-316SS
6. Packing	PTFE	15. Gland Plate	300 Series Stainless Steel
7. Stem Bearing	PEEK/PTFE	16. Lever Handle	300 Series Stainless Steel
8. Body Gasket	PTFE Spiral Wound	17. Lock Plate	300 Series Stainless Steel
9. Body Bolts	ASTM A193-Gr.B8M3	18. Stops	300 Series Stainless Steel
		19. Int. Gmd. Spring	300 Series Stainless Steel
		20. Ext. Gmd. Spring	300 Series Stainless Steel

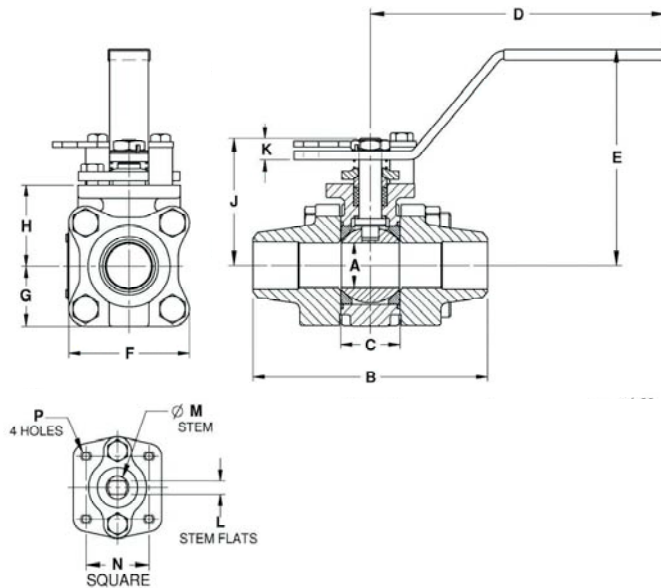

VARIATIONS AVAILABLE:

- 86B-300 - Schedule 5 Butt-weld
- 86B-400 - Schedule 10 Butt-weld
- 86B-600 - Schedule 80 Butt-weld

OPTIONS AVAILABLE:

(SUFFIX)	OPTION	SIZES
-04-	2-1/4" Stem Extension	3/8" to 2"
-14-	Vented Ball (see page J-2)	3/8" to 2"
-15-	Round Handle	3/8" to 2"
-21-	UHMWPE Seats w/Graphite Seals	3/8" to 2"
-24-	Fire Safe - Graphite Packing & Gaskets (API 607, 5th ed., ISO 10497-5)	3/8" to 2"
-49-	Assembled Dry	3/8" to 2"
-57-	Cleaned for Oxygen Service	3/8" to 2"
-69-	Drilled & Tapped Purge & Drains	3/8" to 2"
-70-	Extended Bonnet	3/8" to 2"
-76-	Live Loaded (Lever Operated)	3/8" to 2"
-77-	Live Loaded (Actuated)	3/8" to 2"

For Pressure/Temperature Ratings, Refer to Page M-18, Graph No. 26

STAINLESS STEEL 3-PIECE FULL PORT BALL VALVE

NUMBER	SIZE	A	B	C	D	E	F	G	H	J	K	L	M	N	P	WT.
86B-502-01	3/8"	.50	3.80	0.89	5.12	3.02	2.02	1.01	1.39	1.97	0.23	0.245	0.375	1.00	10-24	2.3
86B-503-01	1/2"	.50	3.80	0.89	5.12	3.02	2.02	1.01	1.39	1.97	0.23	0.245	0.375	1.00	10-24	2.3
86B-504-01	3/4"	0.75	4.66	1.10	5.53	3.40	2.40	1.20	1.65	2.35	0.24	0.312	0.500	1.392	1/4-20	4.0
86B-505-01	1"	1.00	5.19	1.31	6.53	4.80	2.67	1.34	1.80	2.80	0.48	0.287	0.500	1.392	1/4-20	5.7
86B-506-01	1-1/4"	1.50	5.48	1.97	6.65	4.70	3.84	1.92	2.49	3.89	0.72	0.412	0.625	1.949	5/16-18	14.2
86B-507-01	1-1/2"	1.50	5.96	1.97	6.65	4.70	3.84	1.92	2.49	3.89	0.72	0.412	0.625	1.949	5/16-18	14.4
86B-508-01	2"	2.00	6.84	2.56	8.40	5.47	4.92	2.46	3.17	4.74	0.80	0.477	0.750	1.949	5/16-18	27.6