



ARCHON

www.ARCHONind.com



WATER GAUGES AND LIQUID LEVEL GAUGES

COMPLETE INFORMATION FOR SELECTION, ORDERING, INSTALLATION AND USE

Water Gauges and Liquid Level Gauges

Table of Contents

What Is A Water Gauge?	3
How To Select A Water Gauge	3-4
Do's and Don't's	5
Installation	5
Archon Water Gauges And Liquid Level Gauges	6-7
Water Gauges Liquid Level Gauges Dimensions	8-9
Rough Bronze Water Gauges	10
Rough Bronze Water Gauges with Extended Shank	11
Stainless Steel Liquid Level Gauges	11
Rough Bronze Liquid Level Gauges	12
Polished Bronze Water Gauges	12
Gauge Glass Ratings	13
Repair Kits	14
Glossary	15
Warranty	16

sales@ARCHONind.com

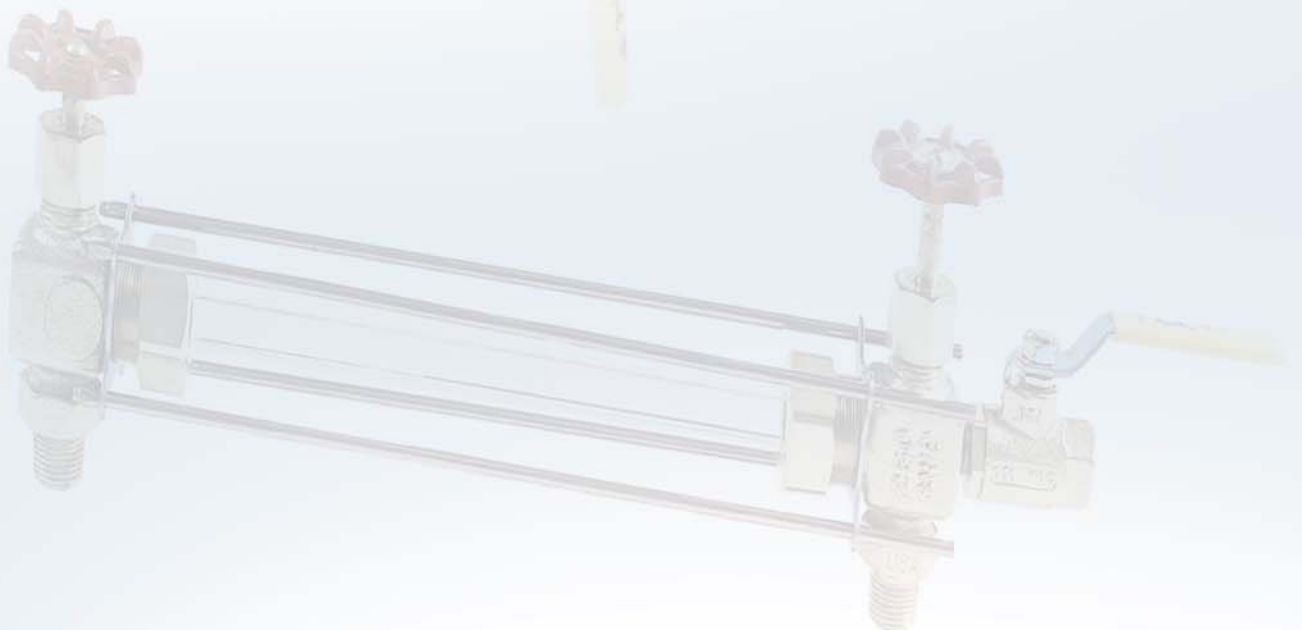

WHAT IS A WATER GAUGE?

A water gauge is a device that allows the liquid level in a vessel to be visually inspected. Water gauges are required by the ASME Boiler and Pressure Code on steam boilers, and are also useful in many other applications, such as monitoring the amount of oil in an oil tank.

THINGS TO REMEMBER

Care must be given to ensure the proper selection of a water gauge. Special attention must be given to temperature/pressure requirements and to the service media (i.e. water, steam, oils, chemical agents, etc.). Some items to keep in mind:

- **PRESSURE RATINGS** may be influenced by limitations of the valve body, gauge glass, and gauge glass gasket. As temperatures increase, pressure ratings decrease. The larger the glass diameter and the longer the glass length, the lower the pressure rating. Refer to the **GAUGE GLASS PRESSURE AND TEMPERATURE TABLE** for detailed information.
- **TEMPERATURE RATINGS** may also be influenced by limitations of the valve body, gauge glass, & gauge glass gasket.
- Use **GUARD RODS** and **TUBULAR GAUGE GLASS PROTECTORS** to help protect glass from accidental breakage. Some applications require glass protectors.
- Use **REDLINE** gauge glass where pressures permit to allow for easy reading of the gauge. Use large diameter (3/4") glass for increased visibility.
- Use **AUTOMATIC BALL CHECKS** to help minimize the risk of property damage or personal injury. Vertically rising automatic ball checks conforming to ASME requirements are available.
- Boilers operating above 400 psig require two water gauges.
- All water gauges on all steam boilers must be 1/2" NPT or larger.



A SPECIAL NOTE ABOUT CORROSION

Most problems with water gauge performance are associated with corrosion. Excessive corrosion may result in leakage, glass breakage, and premature valve failure. There are several things to watch for:

- Be sure all components (valve body, seals and packings, etc.) of the water gauge are constructed with materials compatible with the service medium. Non-standard

packings for special applications may be ordered in our **WATER GAUGE REPAIR KITS**. See the "Compass Corrosion Guide" or equivalent for additional information.

- Elevated temperatures and pressures accelerate corrosion (you may need a stainless steel water gauge instead of bronze, or high pressure glass instead of standard, to achieve an acceptable service life).
- Operation and maintenance - check gauges daily for leaks, corrosion, and gauge glass clarity. Water gauges should be well illuminated and kept clean. Leaks may result in false waterline readings, may damage the gauge, and accelerate corrosion. The appearance of rust in the gauge glass is an indication of improper water treatment. See the ARCHON WATER GAUGE INSTALLATION INSTRUCTIONS (I-5387-00) or the appropriate sections of the ASME Boiler and Pressure Vessel Code for additional information.
- Gauge Glass Corrosion - Gauge glass is attacked and dissolved in service by the fluid media, resulting in thinning of the wall and premature failure or replacement. Two factors determine the rate of attack: alkalinity and temperature. High alkalinity (high pH values) increases the rate of attack (a pH of 11.5 attacks glass at a rate of 30 times greater than a pH of 8.5). High temperatures increase the rate of attack (5000°F water attacks glass 100 times faster than 2650°F water). There is nothing that may be done to reduce the effects of temperature, but the effects of pH may be reduced by maintaining proper pH balance in the boiler water with chemical agents. Glass corrosion may also be decreased by avoiding exposure to water spray and drafts.

HOW TO SELECT A WATER GAUGE

1. Select a valve series based upon the application:

- use 20-400 or 20-410 series for 90° handles or when working in close quarters,
- use 20-600, 24-600, or 25-600 series (chain levers) where the water gauge is located beyond reach from the floor,
- use 20-604/605 (bronze) or 23-650 (stainless steel) series expansion tank gauges when a shut-off is not required in the top valve (**NEVER USE AN EXPANSION TANK GAUGE ON A BOILER!**),
- use 20-800 (bronze) or 23-450 (stainless steel) series expansion tank gauges to mount a pressure gauge or other instrument directly to the water gauge,
- use 20-700 series expansion tank gauge for easier gauge glass replacement,
- use 23-450 series stainless steel for superior corrosion resistance,
- use polished gauges for a more elegant appearance,
- use heavy pattern water gauges (such as 20-200/250, 24-300/350) for higher pressures. **Be sure to verify gauge glass will withstand pressure by consulting the "Gauge Glass Service Rating Table".**
- use longer shank on NPT end when extra shank length is needed to penetrate an outer jacket or insulation (available on 21 series). Otherwise use a standard water gauge.



2. Select Non-Automatic, Automatic, or ASME Automatic:
 - use automatic (horizontally seating) or ASME automatic (vertically rising to seat in lower valve body) ball checks where available to minimize the risk of personal injury and/or property damage in the event of gauge glass breakage. The sudden rush of steam and water seats the balls, thereby shutting off the escape of steam and water. There will however be slight leakage as required by certain codes.
3. Select a handwheel style:
 - use aluminum handwheels for durability.
 - use plastic (composition) handwheels for reduced heat transfer.
 - use chain levers (not available on all models) when the water gauge is located beyond reach from the floor.
4. Select a gauge glass size (diameter):
 - use larger (3/4") diameter gauge glass where available for increased visibility.
5. Select a gauge glass type (based on pressure requirements):
 - use Redline glass for increased fluid level visibility.
 - use high pressure glass for high pressure applications.
 - for economy use standard glass for low pressure applications.
 - replace the two digit suffix in the part number of the water gauge with -10 when selecting Redline or high pressure gauge glass (23 and 24 series have high pressure glass as standard).
6. Select gauge glass length:
 - select a standard gauge glass length when possible.
 - select a non-standard gauge glass length as needed, and replace the two digit suffix in the part number of the water gauge with -10. The longer the gauge glass, the lower the allowable pressure and temperature. Be sure to consult the "Gauge Glass Service Rating Table" for pressure and temperature limits. When selecting non-standard gauge glass lengths, the gauge glass length is determined by the center to center distance and the valve series number according to the tables on pages 8 and 9.
 - for gauge glass longer than 72" it is necessary to use two or more water gauges of shorter length in an overlapped staggered tandem (i.e. for 100" of needed coverage, use two gauges of about 55" and install them parallel and staggered so as to overlap their individual coverage of 55" to get 100" total coverage).
7. Select tubular gauge glass protector:
 - for 5/8" diameter gauge glass, use I-2733-05
 - for 3/4" diameter gauge glass, use I-2734-05
 - maximum protector length is 50"
 - protector not available on 23-300, 23-650, and 24-600 series.
 - Available in brass only
8. Select drain type:
 - Plug drain is standard on 20-400 and 23-600 series. Ball valve drain is standard on 23-400/450 and 24-300/350 series. Needle drain is standard on all others. Ball valve drain or pet cock drain available on most models upon request.
9. Select a gauge glass packing material:
 - use EPDM for most general applications, including steam service, for temperatures -20°F to 350°F. Recommended for water, steam, silicone oils, ketones (MEK, acetone, etc...), alcohol, and brake fluid. Unsuitable for petroleum oils. Comes standard on most models. EPDM is most economical.
 - use Viton® for superior resistance at elevated temperatures -15°F to 400°F (up to 600°F for short periods.) Recommended for petroleum oils, silicone oils, halogenated hydrocarbons (carbon tetrachloride, trichloroethylene), acids. Unsuitable for ketones (MEK, acetone), amines, anhydrous ammonia, hot hydrofluoric or chlorosulfonic acid. Viton® is about ten times more expensive than EPDM.
 - use Hypalon® for superior acid resistance at temperatures -20°F to 450°F. Has a shorter service life than EPDM and Viton® in standard, non-acid applications. More difficult to seal than softer EPDM or Viton®. Comes standard on 23 and 24 series. Hypalon® is equivalent to EPDM in cost.
 - use Teflon® for best chemical resistance, for temperatures up to 450°F. More difficult to seal than Hypalon®, Viton®, or EPDM. Use only when needed for more chemical resistance than Viton® at elevated temperatures. Not recommended for hot fluorine, oxygen difluoride, or chlorine trifluoride. Teflon® is about three times as expensive as EPDM.
 - use Graphite for superior service at elevated temperatures. More difficult to seal than EPDM or Viton® but has more universal application. Graphite is about ten times more expensive than EPDM.
 - Remember, chemical resistance decreases as temperature increases. Consult "Compass Corrosion Guide" or equivalent.
 - To order non-standard gauge glass packing, order the water gauge normally, then also order a "Water Gauge Repair Kit" ("Standard All" for EPDM, Hypalon® and Teflon®, "Viton® Gaskets Only" for Viton®, and "Graphite Gaskets Only" for graphite). Remove the pre-installed packing, and install the desired packing material.

WATER GAUGE DO'S AND DON'T'S

DO NOT's

- DO NOT** use glass if it contains any scratches, chips, or any other visible signs of damage.
- DO NOT** reuse any tubular glass or glass packings.
- DO NOT** subject gauge glass to bending or torsional stresses.
- DO NOT** over tighten glass packing nuts.
- DO NOT** allow glass to touch any metal parts.
- DO NOT** exceed the recommended pressure of the gauge or gauge glass.
- DO NOT** clean the gauge or gauge glass while pressurized or in operation.

DO's

- DO** verify proper gauge has been supplied.
- DO** examine gauge glass and packings carefully for damage before installation.
- DO** install protective guards and utilize automatic ball checks where necessary to help prevent injury in case of glass breakage.
- DO** inspect the gauge glass daily, keep maintenance records, and conduct routine replacements.
- DO** protect glass from sudden changes in temperatures such as drafts, water spray, etc.

MAINTENANCE

Examine the gauge glass regularly for any signs of clouding, scratching, erosion, or corrosion. The glass should be inspected daily until the need for replacement becomes apparent. This will help establish the routine inspection and routine replacement schedules.

CLEANING

Use commercial non-abrasive glass cleaners to keep glass clean. Use diluted acids such as Hydrochloric (muriatic) acid when regular cleaners do not seem to work. Do not use wire brushes or any other abrasive materials which could scratch the glass.

INSPECTION

Examine the surface of the glass for scratches, corrosion, chips, cracks, surface flaws, or nicks. To do this, aim a very bright concentrated light at an angle of about 45 degrees. A defective glass will glisten as the light strikes imperfections. Glass which appears cloudy or roughened, and will not respond to cleaning, should be replaced.

STORING

Keep gauge glass in original packaging until ready to install.

INSTALLATION

Only properly trained personnel should install and maintain water gauge glass and connections. Remember to wear safety gloves and glasses during installation. Before installing, make sure all parts are free of chips and debris.

1. Apply Teflon® tape or pipe dope to pipe threads. Install top gauge fitting (fitting without a drain valve) into the upper most tapping. Wrench tighten the fitting until it is snug and the glass outlet is pointing at five o'clock (about 1/8 turn from its final, downward vertical, position).
2. Install the bottom gauge fitting (the fitting with a drain valve) until it is snug and the glass outlet is pointing directly upward. Verify top and bottom fittings are threaded into the tappings the same number of turns (distance A= distance B).
3. Remove glass packing nut, friction washer (or packing gland **and retaining ring**, depending upon the model), and glass packing from the fittings, and place them, in the same order, on to both ends of the gauge glass. Push both packings about an inch up the gauge glass.
4. Gently insert one end of the glass into the top gauge fitting. Keeping the glass inside the top fitting, gently rotate the top gauge fitting clockwise, using wrench on valve wrench flats, until vertically aligned with the bottom gauge fitting, then insert glass into bottom fitting until glass bottoms out on the shoulder inside the bottom fitting.
5. Carefully raise glass about 1/16" and slide lower glass packing down until the glass packing contacts the lower gauge fitting. **DO NOT** allow the glass to remain in contact with any metal!
6. Carefully slide upper glass packing up as far as possible.
7. Hand tighten both glass packing nuts, then tighten 1/2 turn more by wrench. Tighten only enough to prevent leakage. **DO NOT OVER TIGHTEN!** If any leakage should occur, tighten slightly, a quarter turn at a time, checking for leakage after each turn.

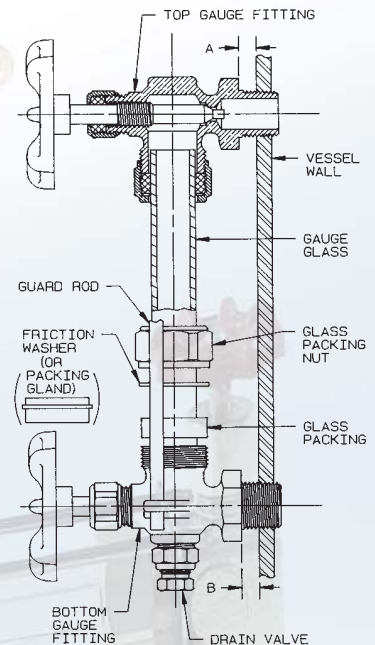

Archon Water Gauges And Liquid Level Gauges



20-100 Series
Standard Pattern



20-150 Standard
Pattern Automatic



20-200 Series
Heavy Pattern



20-250 Heavy
Pattern Automatic



20-300 Series



20-350 Series
Automatic



20-400 Series
Left Hand Illustrated



20-410 Series
Left Hand Only



20-601 & 602
Series



20-604 & 20-605
Series

sales@ARCHONind.com

Archon Water Gauges And Liquid Level Gauges



20-700 Series



20-800 Series



23-450 Series
ASME Automatic



23-600 Series



24-300 Series



24-600 Series



25-200 Series
Heavy Pattern



25-400 Series

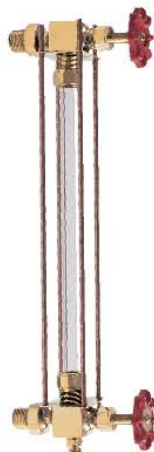

25-500 Series
Automatic



25-600 Series



Water Gauge And Liquid Level Gauge Dimensions

- A = Overall length is found by adding this to dimension "L"
- B = Valve open total depth
- C = Valve closed total depth
- D = Handle diameter
- E = Maximum extension below lower arm centerline
- F = Maximum extension above upper arm centerline
- G = End of arm NPT to centerline of glass
- H = End of arm NPT to hex shoulder
- Glass Length is "L" minus GL code
- Rod Length is glass length plus RL code

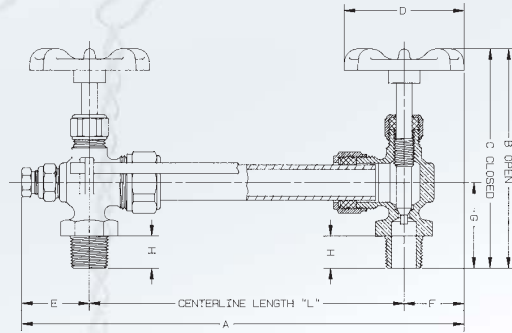

sales@ARCHONind.com

Dimensions												
Valve	Pipe Size	A	B	C	D	E	F	G	H	GL code	RL code	
20-101	3/8	2.315	4.09	3.84	2.13	1.25	1.065	1.5	0.56	1.25	2	
20-102	3/8	2.25	4.31	4.06	2	1.25	1	1.5	0.56	1.25	2	
20-104	1/2	2.315	4.19	3.94	2.13	1.25	1.065	1.63	0.69	1.25	2	
20-105	1/2	2.25	4.43	4.18	2	1.25	1	1.63	0.69	1.25	2	
20-150*	1/2	2.315	4.19	3.94	2.13	1.25	1.065	1.63	0.69	1.25	2	
20-151*	1/2	2.25	4.43	4.18	2	1.25	1	1.63	0.69	1.25	2	
20-201	3/8	2.445	4.44	4.19	2.13	1.38	1.065	1.69	0.56	1.25	2	
20-202	3/8	2.38	4.38	4.13	2	1.38	1	1.69	0.56	1.25	2	
20-204	1/2	2.445	4.56	4.31	2.13	1.38	1.065	1.81	0.69	1.25	2	
20-205	1/2	2.38	4.5	4.25	2	1.38	1	1.81	0.69	1.25	2	
20-207	3/4	2.445	4.88	4.63	2.13	1.38	1.065	2.05	0.75	1.50	2.25	
20-208	3/4	2.38	5.06	4.81	2	1.38	1	2.05	0.75	1.50	2.25	
20-250	1/2	2.445	4.56	4.31	2.13	1.38	1.065	1.81	0.69	1.25	2	
20-251*	1/2	2.38	4.5	4.25	2	1.38	1	1.81	0.69	1.25	2	
20-253*	3/4	2.445	4.88	4.63	2.13	1.38	1.065	2.05	0.75	1.50	2.25	
20-254*	3/4	2.38	5.06	4.81	2	1.38	1	2.05	0.75	1.50	2.25	
20-304	1/2	2.315	5.31	5.06	2.13	1.25	1.065	2.2	0.69	2.00	1.25	
20-305	1/2	2.25	5.5	5.25	2	1.25	1	2.2	0.69	2.00	1.25	
20-307	3/4	2.315	5	5.38	2.13	1.25	1.065	2.06	0.69	2.00	1.25	
20-308	3/4	2.25	5.38	5	2	1.25	1	2.06	0.69	2.00	1.25	
20-350*	1/2	2.315	5.31	5.06	2.13	1.25	1.065	2.2	0.69	2.00	1.25	
20-351*	1/2	2.25	5.5	5.25	2	1.25	1	2.2	0.69	2.00	1.25	
20-353*	3/4	2.315	5	5.38	2.13	1.25	1.065	2.06	0.69	2.00	1.25	
20-354*	3/4	2.25	5.38	5	2	1.25	1	2.06	0.69	2.00	1.25	
20-405	1/2	2	1.88	1.63	1.75	1.14	0.86	1.63	0.69	1.25	NA	
20-406	1/2	2	1.88	1.63	1.75	1.14	0.86	1.63	0.69	1.25	NA	
20-407	1/2	2	1.88	1.63	1.75	1.14	0.86	1.63	0.69	1.25	2	
20-408	1/2	2	1.88	1.63	1.75	1.14	0.86	1.63	0.69	1.25	2	
20-410	1/2	2.28	2.13	1.88	1.75	1.42	0.86	2.09	1.25	1.25	NA	
20-601	1/2	4.19	5.25	4.75	5.88	1.25	2.94	2.09	0.69	2.00	1.25	
20-602	3/4	4.19	5.25	4.75	5.88	1.25	2.94	2.09	0.69	2.00	1.25	
20-604*	1/2	2.07	4.56	4.31	2.13	1.38	0.69	1.81	0.69	1.25	2	
20-605*	1/2	2.07	4.5	4.25	2	1.38	0.69	1.81	0.69	1.25	2	
20-703	3/8	1.78	NA	NA	NA	1.25	0.53	1.5	0.56	1.25	2	
20-704	1/2	1.78	NA	NA	NA	1.25	0.53	1.63	0.69	1.25	2	
20-713	3/8	2.61	NA	NA	NA	1.25	1.36	1.5	0.56	1.25	2	
20-714	1/2	2.61	NA	NA	NA	1.25	1.36	1.63	0.69	1.25	2	

Water Gauge And Liquid Level Gauge Dimensions

Valve	Pipe size	A	B	C	D	E	F	G	H	GL code	RL code
20-804*	1/2	2.13	4.56	4.31	2.13	1.38	0.75	1.81	0.69	1.25	2
20-805*	1/2	2.13	4.5	4.25	2	1.38	0.75	1.81	0.69	1.25	2
21-101	3/8	2.315	5.31	5.06	2.13	1.25	1.065	2.69	1.75	1.25	2
21-102	3/8	2.25	5.5	5.25	2	1.25	1	2.69	1.75	1.25	2
21-104	1/2	2.315	5.31	5.06	2.13	1.25	1.065	2.69	1.75	1.25	2
21-105	1/2	2.25	5.5	5.25	2	1.25	1	2.69	1.75	1.25	2
21-150*	1/2	2.315	5	4.75	2.13	1.25	1.065	2.69	1.75	1.25	2
21-151*	1/2	2.25	5.5	5.25	2	1.25	1	2.69	1.75	1.25	2
21-204	1/2	2.445	5.63	5.38	2.13	1.38	1.065	2.88	1.75	1.25	2
21-205	1/2	2.38	5.56	5.31	2	1.38	1	2.88	1.75	1.25	2
21-250*	1/2	2.445	5.63	5.38	2.13	1.38	1.065	2.88	1.75	1.25	2
21-251*	1/2	2.38	5.63	5.38	2	1.38	1	2.88	1.75	1.25	2
23-401	1/2	4.065	5.56	5.56	2.13	3	1.065	2.13	0.69	2.00	3.25
23-402	1/2	4	5.56	5.56	2	3	1	2.13	0.69	2.00	3.25
23-404	3/4	4.065	5.56	5.06	2.13	3	1.065	2.09	0.75	2.00	3.25
23-405	3/4	4	5.56	5.06	2	3	1	2.09	0.75	2.00	3.25
23-450**	1/2	4.065	5.56	5.06	2.13	3	1.065	2.13	0.69	2.00	3.25
23-451**	1/2	4	5.56	5.06	2	3	1	2.13	0.69	2.00	3.25
23-453**	3/4	4.065	5.56	5.06	2.13	3	1.065	2.09	0.75	2.00	3.25
23-454**	3/4	4	5.56	5.06	2	3	1	2.09	0.75	2.00	3.25
23-651	1/2	1.755	4.63	4.38	2.13	1.065	0.69	2.5	0.69	2.00	1.25
23-654	3/4	1.755	4.63	4.38	2.13	1.065	0.69	2.5	0.75	2.00	1.25
24-301	1/2	4.065	5.75	5.25	2.13	3	1.065	2.09	0.69	2.00	1.25
24-302	1/2	4	5.75	5.25	2	3	1	2.09	0.69	2.00	1.25
24-304	3/4	4.065	5.75	5.25	2.13	3	1.065	2.09	0.69	2.00	1.25
24-305	3/4	4	5.56	5.06	2	3	1	2.09	0.69	2.00	1.25
24-350**	1/2	4.065	5.75	5.25	2.13	3	1.065	2.09	0.69	2.00	1.25
24-351**	1/2	4	5.56	5.06	2	3	1	2.09	0.69	2.00	1.25
24-353**	3/4	4.065	5.75	5.25	2.13	3	1.065	2.09	0.69	2.00	1.25
24-354**	3/4	4	5.56	5.06	2	3	1	2.09	0.69	2.00	1.25
24-601	1/2	5.875	5.25	4.75	5.75	3	2.875	2.09	0.69	2.00	.875
24-602	3/4	5.875	5.25	4.75	5.75	3	2.875	2.09	0.69	2.00	.875
24-651**	1/2	5.875	5.25	4.75	5.75	3	2.875	2.09	0.69	2.00	.875
24-652**	3/4	5.875	5.25	4.75	5.75	3	2.875	2.09	0.69	2.00	.875
25-201	3/8	2.445	4.44	4.19	2.13	1.38	1.065	1.69	0.56	1.25	2
25-202	3/8	2.38	4.38	4.13	2	1.38	1	1.69	0.56	1.25	2
25-204	1/2	2.445	4.56	4.31	2.13	1.38	1.065	1.81	0.69	1.25	2
25-205	1/2	2.38	4.5	4.25	2	1.38	1	1.81	0.69	1.25	2
25-207	3/4	2.445	4.88	4.63	2.13	1.38	1.065	2.05	0.75	1.25	2
25-208	3/4	2.38	5.06	4.81	2	1.38	1	2.05	0.75	1.25	2
25-404	1/2	2.315	5.31	5.06	2.13	1.25	1.065	2.2	0.69	2.00	1.25
25-405	1/2	2.25	5.5	5.25	2	1.25	1	2.2	0.69	2.00	1.25
25-407	3/4	2.315	5.38	5	2.13	1.25	1.065	2.06	0.69	2.00	1.25
25-408	3/4	2.25	5.38	5	2	1.25	1	2.06	0.69	2.00	1.25
25-501*	1/2	2.315	5.31	5.06	2.13	1.25	1.065	2.2	0.69	2.00	1.25
25-502*	1/2	2.25	5.5	5.25	2	1.25	1	2.2	0.69	2.00	1.25
25-504*	3/4	2.315	5.38	5	2.13	1.25	1.065	2.06	0.69	2.00	1.25
25-505*	3/4	2.25	5.38	5	2	1.25	1	2.06	0.69	2.00	1.25
25-601	1/2	5.88	5.25	4.75	5.88	2.94	2.94	2.09	0.69	2.00	1.25
25-602	3/4	5.88	5.25	4.75	5.88	2.94	2.94	2.09	0.69	2.00	1.25

* Automatic

** ASME Automatic

Suffix Key

- 00 Standard set includes top & bottom valves, glass and rods
- 01 Top valve only
- 02 Bottom valve only
- 03 Top & Bottom valves only (no glass or rods)
- 10 For special gauges with non-standard glass, rods, and/or gaskets.

sales@ARCHONind.com



Rough Bronze Water Gauges



Series	Rating (subject to limitation of gauge glass)
20-100	125 psig @ 350°F, 300 psig @ 100°F
20-150	125 psig @ 350°F, 300 psig @ 100°F
20-200	200 psig @ 400°F, 400 psig @ 100°F
20-250	200 psig @ 400°F, 400 psig @ 100°F
20-300	200 psig @ 400°F, 400 psig @ 100°F
20-350	200 psig @ 400°F, 400 psig @ 100°F
20-400	125 psig @ 350°F, 300 psig @ 100°F
20-601, 602	250 psig @ 400°F, 500 psig @ 100°F
20-604, 605	200 psig @ 400°F, 400 psig @ 100°F
20-700	125 psig @ 350°F, 300 psig @ 100°F
20-100	200 psig @ 400°F, 400 psig @ 100°F

sales@ARCHONind.com

Cat. No.	Pipe Size	Standard Glass		Glass Seal	Stem Packing	Standard Glass		Wt./100
		O.D. & length				Type	Handle	
20-101-00	3/8	5/8 x 10		EPDM Rubber	Teflon®	regular	aluminum	145
20-102-00	3/8	5/8 x 10		EPDM Rubber	Teflon®	regular	composite	145
20-104-00	1/2	5/8 x 12		EPDM Rubber	Teflon®	regular	aluminum	160
20-105-00	1/2	5/8 x 12		EPDM Rubber	Teflon®	regular	composite	160
20-150-00*	1/2	5/8 x 12		EPDM Rubber	Teflon®	regular	aluminum	160
20-151-00*	1/2	5/8 x 12		EPDM Rubber	Teflon®	regular	composite	160
20-201-00	3/8	5/8 x 10		EPDM Rubber	Teflon®	regular	aluminum	185
20-202-00	3/8	5/8 x 10		EPDM Rubber	Teflon®	regular	composite	189
20-204-00	1/2	5/8 x 12		EPDM Rubber	Teflon®	regular	aluminum	205
20-205-00	1/2	5/8 x 12		EPDM Rubber	Teflon®	regular	composite	205
20-207-00	3/4	3/4 x 16		EPDM Rubber	Teflon®	regular	aluminum	270
20-208-00	3/4	3/4 x 16		EPDM Rubber	Teflon®	regular	composite	270
20-250-00*	1/2	5/8 x 12		EPDM Rubber	Teflon®	regular	aluminum	195
20-251-00*	1/2	5/8 x 12		EPDM Rubber	Teflon®	regular	composite	200
20-253-00*	3/4	3/4 x 16		EPDM Rubber	Teflon®	regular	aluminum	355
20-254-00*	3/4	3/4 x 16		EPDM Rubber	Teflon®	regular	composite	360
20-304-00	1/2	5/8 x 12		EPDM Rubber	Teflon®	regular	aluminum	260
20-305-00	1/2	5/8 x 12		EPDM Rubber	Teflon®	regular	composite	270
20-307-00	3/4	3/4 x 16		EPDM Rubber	Teflon®	regular	aluminum	345
20-308-00	3/4	3/4 x 16		EPDM Rubber	Teflon®	regular	composite	365
20-350-00*	1/2	5/8 x 12		EPDM Rubber	Teflon®	regular	aluminum	265
20-351-00*	1/2	5/8 x 12		EPDM Rubber	Teflon®	regular	composite	265
20-353-00*	3/4	3/4 x 16		EPDM Rubber	Teflon®	regular	aluminum	360
20-354-00*	3/4	3/4 x 16		EPDM Rubber	Teflon®	regular	composite	365
20-405-00 (RH)	1/2	5/8 x 12		EPDM Rubber	Teflon®	regular	aluminum	165
20-406-00 (LH)	1/2	5/8 x 12		EPDM Rubber	Teflon®	regular	aluminum	165
20-407-00 (RH)	1/2	5/8 x 12		EPDM Rubber	Teflon®	regular	aluminum	170
20-408-00 (LH)	1/2	5/8 x 12		EPDM Rubber	Teflon®	regular	aluminum	170
20-410-00 (LH)	1/2	5/8 x 12		EPDM Rubber	Teflon®	regular	aluminum	180
20-601-00	1/2	5/8 x 12		EPDM Rubber	Teflon®	regular	chain	370
20-602-00	3/4	3/4 x 16		EPDM Rubber	Teflon®	regular	chain	435
20-604-00*	1/2	5/8 x 12		EPDM Rubber	Teflon®	regular	aluminum	155
20-605-00*	1/2	5/8 x 12		EPDM Rubber	Teflon®	regular	composite	175
20-703-00	3/8	5/8 x 10		EPDM Rubber	na	regular	na	120
20-713-00	3/8	5/8 x 12		EPDM Rubber	na	regular	na	120
20-704-00	1/2	5/8 x 12		EPDM Rubber	na	regular	na	135
20-714-00	1/2	5/8 x 12		EPDM Rubber	na	regular	na	135
20-804-00*	1/2	5/8 x 12		EPDM Rubber	Teflon®	regular	aluminum	160
20-805-00*	1/2	5/8 x 12		EPDM Rubber	Teflon®	regular	composite	160

* Automatic Teflon® is a registered trademark of DuPont.

Rough Bronze Water Gauges With Extended Shank



Series	Rating (subject to limitation of gauge glass)
21-100	125 psig @ 350°F, 300 psig @ 100°F
21-150	125 psig @ 350°F, 300 psig @ 100°F
21-200	200 psig @ 400°F, 400 psig @ 100°F
21-250	200 psig @ 400°F, 400 psig @ 100°F

Cat. No.	Pipe Size	Standard Glass O.D. & length	Glass Seal	Stem Packing	Handle	Standard Glass Type	Wt./100	Shank Length
21-104	1/2	5/8 x 12	EPDM Rubber	Teflon®	aluminum	regular	185	1 3/4
21-105	1/2	5/8 x 12	EPDM Rubber	Teflon®	composite	regular	197	1 3/4
21-150*	1/2	5/8 x 12	EPDM Rubber	Teflon®	aluminum	regular	195	1 3/4
21-151*	1/2	5/8 x 12	EPDM Rubber	Teflon®	composite	regular	207	1 3/4
21-204	1/2	5/8 x 12	EPDM Rubber	Teflon®	aluminum	regular	215	1 3/4
21-205	1/2	5/8 x 12	EPDM Rubber	Teflon®	composite	regular	219	1 3/4
21-250*	1/2	5/8 x 12	EPDM Rubber	Teflon®	aluminum	regular	215	1 3/4
21-251*	1/2	5/8 x 12	EPDM Rubber	Teflon®	composite	regular	215	1 3/4

*Automatic

1 Teflon® is a registered trademark of DuPont.

Stainless Steel Liquid Level Gauge

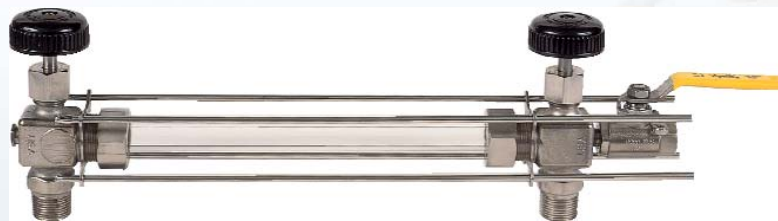

Series	Rating (subject to limitation of gauge glass)
23-401	500 psig @ 450°F
23-450	500 psig @ 450°F
23-650	250 psig @ 406°F

Cat. No.	Pipe Size	Standard Glass O.D. & length	Glass Seal	Stem Packing	Handle	Standard Glass Type	Wt./100
23-401	1/2	5/8 x 12	PTFE w/Hypalon®	Braided PTFE w/Aramid	aluminum	high pressure	385
23-402	1/2	5/8 x 12	PTFE w/Hypalon®	Braided PTFE w/Aramid	composition	high pressure	385
23-404	3/4	3/4 x 16	PTFE w/Hypalon®	Braided PTFE w/Aramid	aluminum	high pressure	450
23-405	3/4	3/4 x 16	PTFE w/Hypalon®	Braided PTFE w/Aramid	composition	high pressure	450
23-450**	1/2	5/8 x 12	PTFE w/Hypalon®	Braided PTFE w/Aramid	aluminum	high pressure	390
23-451**	1/2	5/8 x 12	PTFE w/Hypalon®	Braided PTFE w/Aramid	composition	high pressure	390
23-453**	3/4	3/4 x 16	PTFE w/Hypalon®	Braided PTFE w/Aramid	aluminum	high pressure	455
23-454**	3/4	3/4 x 16	PTFE w/Hypalon®	Braided PTFE w/Aramid	composition	high pressure	455
23-651	1/2	5/8 x 12	PTFE w/Hypalon®	Teflon® ¹	aluminum	high pressure	225
23-654	3/4	5/8 x 12	PTFE w/Hypalon®	Teflon®	composition	high pressure	225

** ASME Automatic

Teflon® and Hypalon® are registered trademarks of DuPont.



Rough Bronze Liquid Level Gauge

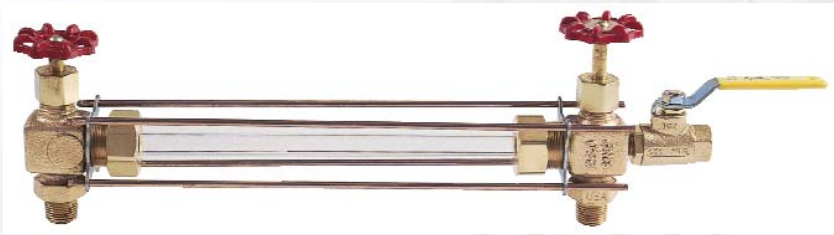

Series	Rating (subject to limitation of gauge glass)
24-300	250 psig @ 400°F, 500 psig @ 100°F
24-350	250 psig @ 400°F, 500 psig @ 100°F
24-600	250 psig @ 400°F, 500 psig @ 100°F
24-650	250 psig @ 400°F, 500 psig @ 100°F
24-750	250 psig @ 400°F, 500 psig @ 100°F
24-850	250 psig @ 400°F, 500 psig @ 100°F

Cat. No.	Pipe Size	Standard Glass			Stem Packing	Handle	Standard Glass	
		O.D. & length	Glass Seal	Type			Wt./100	
24-301	1/2	5/8 x 12	PTFE w/Hypalon®	Braided PTFE w/Aramid	aluminum	high pressure	425	
24-302	1/2	5/8 x 12	PTFE w/Hypalon®	Braided PTFE w/Aramid	composition	high pressure	425	
24-304	3/4	3/4 x 16	PTFE w/Hypalon®	Braided PTFE w/Aramid	aluminum	high pressure	490	
24-305	3/4	3/4 x 16	PTFE w/Hypalon®	Braided PTFE w/Aramid	composition	high pressure	490	
24-350**	1/2	5/8 x 12	PTFE w/Hypalon®	Braided PTFE w/Aramid	aluminum	high pressure	425	
24-351**	1/2	5/8 x 12	PTFE w/Hypalon®	Braided PTFE w/Aramid	composition	high pressure	425	
24-353**	3/4	3/4 x 16	PTFE w/Hypalon®	Braided PTFE w/Aramid	aluminum	high pressure	490	
24-354**	3/4	3/4 x 16	PTFE w/Hypalon®	Braided PTFE w/Aramid	composition	high pressure	490	
24-601	1/2	5/8 x 12	PTFE w/Hypalon®	Braided PTFE w/Aramid	chain	high pressure	515	
24-602	3/4	3/4 x 16	PTFE w/Hypalon®	Braided PTFE w/Aramid	chain	high pressure	580	
24-651**	1/2	5/8 x 12	PTFE w/Hypalon®	Braided PTFE w/Aramid	chain	high pressure	515	
24-652**	3/4	3/4 x 16	PTFE w/Hypalon®	Braided PTFE w/Aramid	chain	high pressure	580	

**ASME Automatic Hypalon® is a registered trademark of DuPont.

Polished Bronze Water Gauge



Series	Rating (subject to limitation of gauge glass)
25-200	200 psig @ 400°F, 400 psig @ 100°F
25-400	125 psig @ 350°F, 300 psig @ 100°F
25-500	200 psig @ 400°F, 400 psig @ 100°F
25-600	250 psig @ 400°F, 500 psig @ 100°F

Cat. No.	Pipe Size	Standard Glass			Stem Packing	Handle	Standard Glass	
		O.D. & length	Glass Seal	Type			Wt./100	
25-201	3/8	5/8 x 10	EPDM rubber	PTFE w/Hypalon®	aluminum	regular	180	
25-202	3/8	5/8 x 10	EPDM rubber	PTFE w/Hypalon®	composition	regular	185	
25-204	1/2	5/8 x 12	EPDM rubber	PTFE w/Hypalon®	aluminum	regular	190	
25-205	1/2	5/8 x 12	EPDM rubber	PTFE w/Hypalon®	composition	regular	190	
25-207	3/4	3/4 x 16	EPDM rubber	PTFE w/Hypalon®	aluminum	regular	290	
25-208	3/4	3/4 x 16	EPDM rubber	PTFE w/Hypalon®	composition	regular	295	
25-404#	1/2	5/8 x 12	EPDM rubber	PTFE w/Hypalon®	aluminum	regular	285	
25-405#	1/2	5/8 x 12	EPDM rubber	PTFE w/Hypalon®	composition	regular	285	
25-407	3/4	3/4 x 16	EPDM rubber	PTFE w/Hypalon®	aluminum	regular	350	
25-408	3/4	3/4 x 16	EPDM rubber	PTFE w/Hypalon®	composition	regular	350	
25-501*	1/2	5/8 x 12	EPDM rubber	PTFE w/Hypalon®	aluminum	regular	290	
25-502*	1/2	5/8 x 12	EPDM rubber	PTFE w/Hypalon®	composition	regular	290	
25-504*	3/4	3/4 x 16	EPDM rubber	PTFE w/Hypalon®	aluminum	regular	355	
25-505*	3/4	3/4 x 16	EPDM rubber	PTFE w/Hypalon®	composition	regular	355	
25-601	1/2	5/8 x 12	EPDM rubber	Graphite w/Aramid	chain	regular	335	
25-602	3/4	3/4 x 16	EPDM rubber	Graphite w/Aramid	chain	regular	350	

#Valve bodies made from brass bar stock

*Automatic Hypalon® is a registered trademark of DuPont.

sales@ARCHONind.com

Gauge Glass Service Rating, Pressure-Temperature Ratings



TUBULAR GAUGE GLASS PROTECTOR

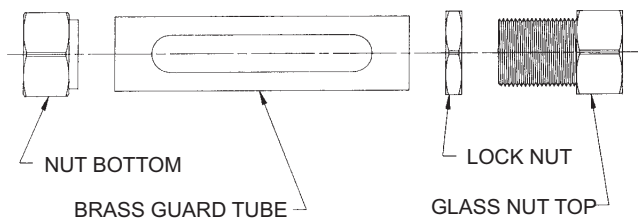

- Reduces the risk of injury and damage from broken exploding glass.
 - Made to fit most water gauges.
 - Priced according to length and application.
 - Maximum protector length of 50".
 - Tubular gauge glass protector not available on the 23-400, 23-650, and 24-600 series.
 - Maximum of 50" length
- Give series number and centerline distance "L" when ordering.

Type	OD Size	tol.	Wall	tol.	Length	Maximum Recommended Working Pressure, psi	
						Temperatures to 150°F, no corrosion	Steam boiler service to 425°F
Standard	5/8	+0, -3/64	5/64	+1/64	8	210	100
Standard	5/8	+0, -3/64	5/64	+1/64	10	210	100
Standard	5/8	+0, -3/64	5/64	+1/64	12	205	100
Standard	5/8	+0, -3/64	5/64	+1/64	14	200	100
Standard	5/8	+0, -3/64	5/64	+1/64	16	195	100
Standard	5/8	+0, -3/64	5/64	+1/64	18	190	100
Standard	5/8	+0, -3/64	5/64	+1/64	24	180	100
Standard	5/8	+0, -3/64	5/64	+1/64	30	175	**
Standard	5/8	+0, -3/64	5/64	+1/64	36	165	**
Standard	5/8	+0, -3/64	5/64	+1/64	48	140	**
Standard	5/8	+0, -3/64	5/64	+1/64	60	120	**
Standard	5/8	+0, -3/64	5/64	+1/64	72	100	**
Standard	3/4	+0, -3/64	3/32	+1/64	8	210	100
Standard	3/4	+0, -3/64	3/32	+1/64	10	210	100
Standard	3/4	+0, -3/64	3/32	+1/64	12	205	100
Standard	3/4	+0, -3/64	3/32	+1/64	14	200	100
Standard	3/4	+0, -3/64	3/32	+1/64	16	195	100
Standard	3/4	+0, -3/64	3/32	+1/64	18	190	100
Standard	3/4	+0, -3/64	3/32	+1/64	24	180	100
Standard	3/4	+0, -3/64	3/32	+1/64	30	175	**
Standard	3/4	+0, -3/64	3/32	+1/64	36	165	**
Standard	3/4	+0, -3/64	3/32	+1/64	48	140	**
Standard	3/4	+0, -3/64	3/32	+1/64	60	120	**
Standard	3/4	+0, -3/64	3/32	+1/64	72	100	**
High Pressure	5/8	+0, -1/32	3/32	+1/64	8	435	320
High Pressure	5/8	+0, -1/32	3/32	+1/64	10	420	315
High Pressure	5/8	+0, -1/32	3/32	+1/64	12	410	305
High Pressure	5/8	+0, -1/32	3/32	+1/64	14	390	295
High Pressure	5/8	+0, -1/32	3/32	+1/64	16	375	285
High Pressure	5/8	+0, -1/32	3/32	+1/64	18	360	280
High Pressure	5/8	+0, -1/32	3/32	+1/64	20	350	270
High Pressure	5/8	+0, -1/32	3/32	+1/64	24	320	255
High Pressure	5/8	+0, -1/32	3/32	+1/64	30	280	**
High Pressure	5/8	+0, -1/32	3/32	+1/64	36	245	**
High Pressure	5/8	+0, -1/32	3/32	+1/64	48	195	**
High Pressure	5/8	+0, -1/32	3/32	+1/64	60	150	**
High Pressure	5/8	+0, -1/32	3/32	+1/64	72	100	**
High Pressure	3/4	+0, -1/32	3/32	+1/64	8	425	315
High Pressure	3/4	+0, -1/32	3/32	+1/64	10	410	310
High Pressure	3/4	+0, -1/32	3/32	+1/64	12	400	300
High Pressure	3/4	+0, -1/32	3/32	+1/64	14	385	290
High Pressure	3/4	+0, -1/32	3/32	+1/64	16	370	280
High Pressure	3/4	+0, -1/32	3/32	+1/64	18	355	275
High Pressure	3/4	+0, -1/32	3/32	+1/64	20	345	265
High Pressure	3/4	+0, -1/32	3/32	+1/64	24	315	250
High Pressure	3/4	+0, -1/32	3/32	+1/64	30	275	**
High Pressure	3/4	+0, -1/32	3/32	+1/64	36	240	**
High Pressure	3/4	+0, -1/32	3/32	+1/64	48	190	**
High Pressure	3/4	+0, -1/32	3/32	+1/64	60	145	**
High Pressure	3/4	+0, -1/32	3/32	+1/64	72	100	**
Redline	5/8	+0, -1/32	3/32	+1/64	8	370	285
Redline	5/8	+0, -1/32	3/32	+1/64	10	345	280
Redline	5/8	+0, -1/32	3/32	+1/64	12	335	280
Redline	5/8	+0, -1/32	3/32	+1/64	14	325	275
Redline	5/8	+0, -1/32	3/32	+1/64	16	315	270
Redline	5/8	+0, -1/32	3/32	+1/64	18	305	265
Redline	5/8	+0, -1/32	3/32	+1/64	20	290	265
Redline	5/8	+0, -1/32	3/32	+1/64	24	265	255
Redline	5/8	+0, -1/32	3/32	+1/64	30	235	**
Redline	5/8	+0, -1/32	3/32	+1/64	36	205	**
Redline	5/8	+0, -1/32	3/32	+1/64	48	165	**
Redline	5/8	+0, -1/32	3/32	+1/64	60	125	**
Redline	5/8	+0, -1/32	3/32	+1/64	72	90	**
Redline	3/4	+0, -1/32	3/32	+1/64	8	360	280
Redline	3/4	+0, -1/32	3/32	+1/64	10	340	275
Redline	3/4	+0, -1/32	3/32	+1/64	12	330	275
Redline	3/4	+0, -1/32	3/32	+1/64	14	320	270
Redline	3/4	+0, -1/32	3/32	+1/64	16	310	265
Redline	3/4	+0, -1/32	3/32	+1/64	18	300	260
Redline	3/4	+0, -1/32	3/32	+1/64	20	285	260
Redline	3/4	+0, -1/32	3/32	+1/64	24	260	250
Redline	3/4	+0, -1/32	3/32	+1/64	30	230	**
Redline	3/4	+0, -1/32	3/32	+1/64	36	200	**
Redline	3/4	+0, -1/32	3/32	+1/64	48	160	**
Redline	3/4	+0, -1/32	3/32	+1/64	60	125	**
Redline	3/4	+0, -1/32	3/32	+1/64	72	90	**

**Maximum recommended length in this service is 24".

Part No.	Size	Length
I-2733-05	5/8" O.D. glass	Up to 12" long
I-2733-05L	5/8" O.D. glass	12" to 24" long
I-2734-05	3/4" O.D. glass	Up to 16" long
I-2734-05L	3/4" O.D. glass	16" to 24" long

Water Gauge Repair Kits

The standard repair kits contain glass packing, stem packing, friction washers, seat washers, and drain washer applicable to the particular valve. Three types of glass packing, EPDM rubber, Hypalon®, and Virgin Teflon®, are included in the standard repair kit. For oil related service, Fluorelastomer (Viton®) glass gasket sets are available. For severe applications, graphite glass gaskets and stem packing sets are available for each model.

Repair Kit Ordering Information

Example: 20-001 - 01

DESIGNATION	KIT TYPE	KIT NUMBER
20-00 = Water gauge repair kit	1 = Standard All	01 08
	2 = Viton gaskets only	02 09
	3 = Graphite Gaskets Only	03 10
		04 11
		05 12
		06 13
		07 14

Repair Kit Applications

Kit	Applications
20-001-01	20-101, 20-102, 20-104, 20-105, 20-150, 20-151,
20-003-01	20-405, 20-406, 20-407, 20-408, 20-410
	21-101, 21-102, 21-104, 21-105, 21-150, 21-151,
20-001-02	20-201, 20-202, 20-204, 20-205, 20-250, 20-251, 20-304, 20-305, 20-350, 20-351
20-003-02	20-604, 20-605, 20-804, 20-805, 21-204, 21-205, 21-250, 21-251, 25-201, 25-202, 25-204, 25-205, 25-404, 25-405, 25-501, 25-502
20-001-03	20-207, 20-208, 20-253, 20-254, 20-307, 20-308, 20-353, 20-354
20-003-03	25-207, 25-208, 25-407, 25-408, 25-504, 25-505
20-001-04	20-601, 25-601
20-003-04	
20-001-05	20-602, 25-602
20-003-05	
20-001-06	20-703, 20-704, 20-713, 20-714
20-003-06	
20-001-07	23-401, 23-402, 23-450, 23-451
20-003-07	
20-001-08	20-405, 20-406, 20-407, 20-408
20-003-08	
20-001-09	23-404, 23-405, 23-453, 23-454
20-003-09	
20-001-10	23-651, 23-654
20-003-10	
20-001-11	24-301, 24-302, 24-350, 24-351, 24-450, 24-451
20-003-11	
20-001-12	24-304, 24-305, 24-353, 24-354, 24-453, 24-454
20-003-12	
20-001-13	24-601, 24-651, 24-751, 24-851
20-003-13	
20-001-14	24-602, 24-652, 24-752, 24-852
20-003-14	
20-002-01	20-101, 20-102, 20-104, 20-105, 20-150, 20-151, 20-201, 20-202, 20-204, 20-205, 20-250, 20-251, 20-304, 20-305, 20-350, 20-351, 20-405, 20-406, 20-407, 20-408, 20-410, 20-601, 20-604, 20-605, 20-703, 20-704, 20-713, 20-714, 20-804, 20-805, 21-101, 21-102, 21-104, 21-105, 21-150, 21-151, 21-204, 21-205, 21-250, 21-251, 23-651, 23-654, 25-201, 25-202, 25-204, 25-205, 25-404, 25-405, 25-501, 25-502, 25-601
20-002-02	20-207, 20-208, 20-253, 20-254, 20-307, 20-308, 20-353, 20-354, 25-207, 25-208, 25-407, 25-408, 25-504, 25-505, 20-602, 25-602
20-002-03	23-401, 23-402, 23-450, 23-451, 24-301, 24-302, 24-350, 24-351, 24-450, 24-451, 24-601, 24-651, 24-751, 24-851
20-002-04	23-404, 23-405, 23-453, 23-454, 24-304, 24-305, 24-353, 24-354, 24-453, 24-454, 24-602, 24-652, 24-752, 24-852

Hypalon®, Teflon® and Viton® are registered trademarks of DuPont.

Repair Kit Selection Instructions

It is helpful to determine the following information when ordering a repair kit.

- Model number (if not available describe gauge, i.e. material, # guard rods, NPT size, etc.)
- Glass O.D. and type
- Handle type
- Service media, temperature, and pressure

If you know the model number just examine the "Repair Kit Applications" chart to select kit number for your valve. To order the standard kit, or Viton®, or graphite gaskets, assemble the ordering matrix for the desired kit number.

If you are unable to determine model number please determine the above information and call customer service for assistance.

For replacement glass please determine the above information in addition to the "L" dimension and call customer service. "L" dimension (center to center height of water gauge inlets).

Water Gauge & Gauge Glass Repair Kit Instructions

Only properly trained personnel should install, maintain and repair water gauge glass and connections. Remember to wear safety gloves and glasses during installation/repair. Before installing, make sure all parts are free of chips and debris.

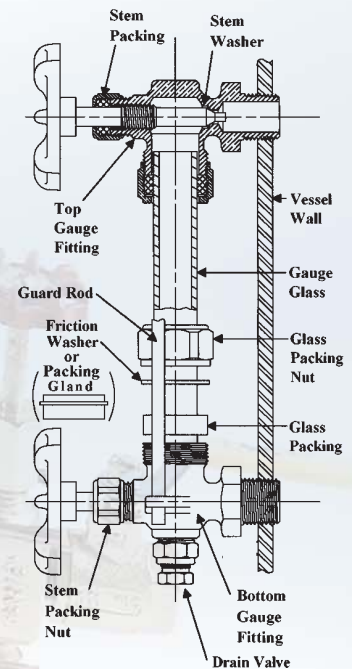

Disassembly/Assembly

1. Close water gauge valves. If necessary drain vessel to eliminate leakage during repair. Drain gauge glass using drain valve or plug.
2. Completely loosen both glass packing nuts.
3. Gently raise gauge glass until bottom of gauge glass clears lower fitting.
4. Using a wrench attached to the hex flats on the upper fitting, lift glass and packing nut then rotate the fitting and glass 1/8 turn counterclockwise.
5. Carefully remove the gauge glass from the upper fitting. Remove all glass packing, packing nuts, washers and packing glands, noting their positions on the glass.
6. Clean and inspect gauge glass and fittings for any wear, erosion, cracks or debris. Any damaged components must be replaced.
7. If it is desired, the stem packing can be replaced by removing the handle(s) then the stem packing nut. Remove old packing and stem packing washer if applicable. Install new packing in stem packing nut and reuse stem packing washer as applicable.
8. To replace seat washers (where applicable) the system must be drained. After removing the stem packing nut reinstall handle and remove stem by opening valve. Cut off old seat washer and install new seat washer using appropriate size tube driver.
9. Install stem until it seats. Remove handle and install stem packing nut with packing inside. Tighten stem packing nut until snug using wrench.
10. Place glass packing nut, friction washer (or packing gland and retaining ring, depending upon the model), and new glass packing, in the same order as found, on to both ends of the gauge glass. Push both packings about an inch up the gauge glass.
11. Gently insert one end of the glass into the top gauge fitting. Keeping the glass inside the top fitting, gently rotate the top gauge fitting clockwise, using wrench on valve hex flats, until vertically aligned with the bottom gauge fitting. Insert glass into bottom fitting until glass bottoms out on the shoulder inside the bottom fitting.
12. Carefully raise glass about 1/16" and slide lower glass packing down until the glass packing bottoms out. DO NOT allow the glass to remain in contact with any metal!
13. Carefully slide upper glass packing up as far as possible.
14. Hand tighten both glass packing nuts, then tighten 1/2 turn more by wrench. Tighten only enough to prevent leakage. DO NOT OVER TIGHTEN! If any leakage should occur, tighten slightly, a quarter turn at a time, checking for leakage after each turn.

GLOSSARY

AUTOMATIC / ASME AUTOMATIC / NON-AUTOMATIC WATER GAUGES: An automatic water gauge is one that is equipped with ball checks in the valve body. In the event of glass breakage, these ball checks move horizontally, automatically seat to close the valves, shut off the flow of fluid, and help reduce the risk of property damage and/or personal injury from released fluid. An ASME automatic water gauge has a ball check in the bottom valve body that rises vertically to seat, and has a ball check in the top valve body that moves horizontally to seat.

BALL VALVE: A bronze or stainless steel on-off valve utilizing a cored chrome-plated brass or stainless steel ball and Teflon seals. Easier to use than plug drains, pet cocks, or needle drains.

CENTER TO CENTER: The distance between the centers of the two N.P.T. tapped holes in the vessel where the water gauge is to be attached.

CHAIN LEVER: A lever handle activated by pulling a chain. Use for high, hard to reach installations.

EPDM: Ethylene propylene rubber gauge glass packing, for temperatures -20°F to 350°F. Recommended for water, steam, silicone oils, ketones (MEK, acetone, etc...), alcohol, and brake fluid. Unsuitable for petroleum oils.

FRICTION WASHER: The thin metal washer used to separate a packing from a metal surface to reduce friction. This in turn reduces the risk of inducing damaging torsional stress in the packing or gauge glass (torsional stress may reduce the useful life of the packing and gauge glass.)

GAUGE GLASS: The transparent part of a water gauge assembly connected directly to a boiler, below and above the waterline, to indicate the level of water in the boiler.

GLASS PACKING: The larger soft rubber-like or plastic ring, when compressed, provides a seal between the gauge glass and the valve body.

GLASS PACKING NUT: The metal nut that the tubular gauge glass passes through. Tighten this nut to effect a seal between the glass packing and the gauge glass.

GRAPHITE: Gaskets formed using graphite yarn. Suitable for temperatures up to 1200°F. Use when necessary for extended service at elevated temperatures.

GUARD RODS: Guard rods are metal rods, mounted to the valve bodies or guard rod flange, that rise vertically to help protect the gauge glass from accidental breakage.

HANDWHEEL: The aluminum or plastic (composition) handle. Also see chain lever.

HYPALON®: TFE (an endless Tetrafluoroethylene Aramid) gauge glass packing ring w/Hypalon as a binder, suitable for temperatures from -20°F to 450°F. More difficult to seal than softer EPDM or Viton™ Rubbers. Use only when needed for superior acid resistance.

NEEDLE DRAIN: A two piece drain (requires a wrench) that allows fluid to flow through an axial outlet.

PACKING GLAND: The shouldered metal ring used in some models to supply extra compression to the gauge glass packing.

PET COCK: A brass or bronze tapered plug, metal seated on-off valve.

PLUG DRAIN: A tapped opening (together with a threaded plug and drain seal) in the bottom of the lower valve body, to allow fluid to drain from the water gauge. This type drain requires a wrench for installation/removal. This type drain is not recommended for hazardous fluids (the fluid may come into contact with the operator).

SEAT WASHER: The small white Teflon™ plastic ring sometimes used to seal the metal valve seat.

STEM PACKING: The smaller soft rubber-like or plastic ring, when compressed, provides a seal between the valve stem and the valve body.

STEM PACKING NUT: The metal nut that the valve stem passes through. Tighten this nut to effect a seal between the stem packing and the stem.

STEM PACKING WASHER: The thin metal washer on the stem that serves as a friction washer and protects against extrusion of the packing.

TEFLON®: Virgin PTFE fluoropolymer gauge glass packing or seat washer, for temperatures up to 450°F. More difficult to seal than Hypalon™. Use only when needed for more chemical resistance than Viton™ at elevated temperatures. Not recommended for hot fluorine, oxygen difluoride, or chlorine trifluoride.

TUBULAR GAUGE GLASS PROTECTOR: A metal or impact-resistant plastic tube that fits over the gauge glass, to protect the glass from accidental breakage, and to help minimize the risk of personal injury and/or property damage. The use of a glass protector, where available, is recommended for all water gauge applications.

VITON®: Fluorocarbon rubber (FKM) gauge glass packing, for temperatures -15°F to 400°F (up to 600°F for short periods.) Use for superior resistance at elevated temperatures. Recommended for petroleum oils, silicone oils, halogenated hydrocarbons (carbon tetrachloride, trichloroethylene), acids. Unsuitable for ketones (MEK, acetone), amines, anhydrous ammonia, hot hydrofluoric or chlorosulfonic acid.

WATER GAUGE: The gauge glass and its fittings for attachment.

Other Archon® Literature for Your Specification Library

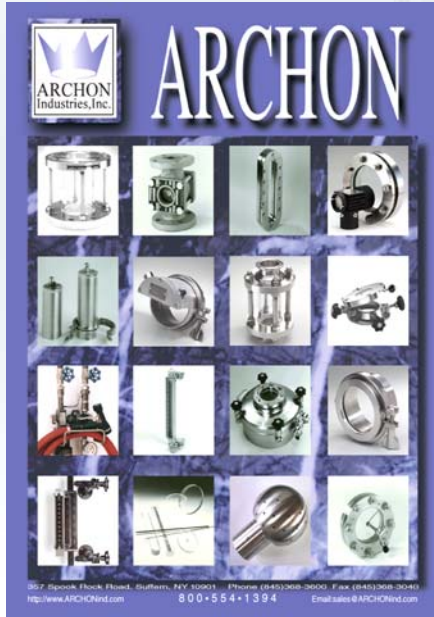

sales@ARCHONind.com

Warranty And Limitations Of Liability

Archon Industries, Inc. warrants, to its initial purchaser only, that its products which are delivered to this initial purchaser will be of the kind described in the order or price list and will be free of defects in workmanship or material for a period of one year from the date of delivery to you, our initial purchaser.

Should any failure to conform to this warranty appear within one year after the date of the initial delivery to our initial purchaser, Archon will, upon written notification thereof and substantiation that the goods have been stored, installed, maintained and operated in accordance with Archon's recommendations and standard industry practice, correct such defects by suitable repair or replacement at Archon's own expense.

THIS WARRANTY IS EXCLUSIVE AND IS IN LIEU OF ANY IMPLIED WARRANTY OF MERCHANTABILITY, FITNESS FOR A PARTICULAR PURPOSE OR OTHER WARRANTY OF QUALITY WHETHER EXPRESSED OR IMPLIED, EXCEPT THE WARRANTY OF TITLE AND

AGAINST PATENT INFRINGEMENT. Correction of non-conformities, in

the manner and for the period of time provided above, shall constitute fulfillment of all liabilities of Archon to our initial purchaser, with respect to the goods, whether based on contract, negligence, strict tort or otherwise. It is the intention of Archon Industries, Inc. that no warranty of any kind, whether express or implied, shall pass through our initial purchaser to any other person or corporation.

LIMITATION OF LIABILITY: Archon Industries, Inc. SHALL NOT UNDER ANY CIRCUMSTANCES BE LIABLE FOR SPECIAL OR CONSEQUENTIAL DAMAGES SUCH AS, BUT NOT LIMITED TO, DAMAGES OR LOSS OF OTHER PROPERTY OR EQUIPMENT, LOSS OF PROFITS OR REVENUE, COST OF CAPITAL, COST OF PURCHASED OR INITIAL PURCHASER, AND ALL OTHERS, SET FORTH HEREIN ARE EXCLUSIVE, AND THE LIABILITY OF ARCHON WITH RESPECT TO SAME SHALL NOT, AS EXPRESSLY PROVIDED HEREIN, EXCEED THE PRICE OF THE GOODS UPON WHICH SUCH LIABILITY IS BASED.