

## ***PL Series Non-metallic UltraSwitch™***

### **Introduction:**

The PL series UltraSwitch™ is U.L. listed and CSA certified to nonincendive standards for Class 1, Division 2 hazardous locations. This position indicator features “quick-set” tool-free adjustment cams for ease of position sensing adjustment. The PL comes standard with a Pharos™ position indicator or a flat top for a lower profile. Many switch options can be installed to meet each applications’ needs. Each integral switch is pre-wired to a multi-point terminal block. A minimum of two spare terminals are provided for external accessories to eliminate costly junction boxes. The enclosure includes two 3/4" N.P.T. conduit connections for easy wiring access.



### **Applications:**

The PL enclosure is manufactured from high-strength, corrosion resistant resin. It will provide accurate and reliable hazardous location position signaling. Many switch options are available to meet your electrical specifications. This watertight position indicator will mount to any Rack and Pinion, Scotch Yoke, Vane, or other rotary actuator type.

The PL may be installed on any actuator conforming to the NAMUR standard for accessory mounting bolt pattern and pinion height without a coupler (see Bulletin PS0037-CV). This reduces deadband and is less expensive. Automax also offers a full line of mounting hardware for non-NAMUR actuators.

Durable construction and corrosion resistant materials provide protection against the toughest applications in all process industries including:

1. Chemical and Petro-Chemical
2. Power
3. Food and Beverage
4. Pharmaceutical
5. Municipal and Wastewater treatment

Flowserve Corporation  
Flow Control Division  
www.flowserve.com

1350 N. Mountain Springs Parkway  
Springville, Utah 84663-3004  
Phone: 801 489 8611

1978 Foreman Dr.  
Cookeville, TN 38501  
Phone: 931 432 4021

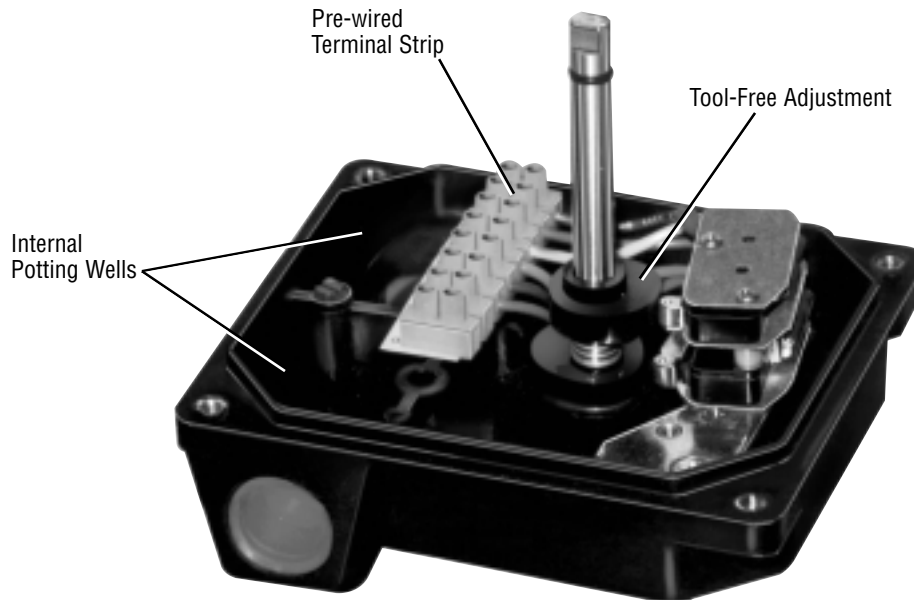
**Features:**

1. **Quick-Set Cams.** Tool free adjustment of switch trip point is accomplished simply by pushing or pulling the cam and rotating it to the new position. Cams are spring-loaded and splined to maintain switch setting in any installed position. They are fully adjustable through 360° in 4° increments.
2. **Corrosion Resistant Materials.** All exposed parts are either stainless steel, nickel-plated brass, or DuPont Zytel® engineered resin to permit use in corrosive environments.
3. **Captive Cover Screws** permit calibration without potential for losing screws.
4. Optional **Pharos™ Visual Position Indicator** provides fully adjustable, high-contrast, full-angle viewing of valve position.
5. Numbered, pre-wired Multi-point **Terminal Strip** for easy hookup. Two spare terminals are provided with every switch to accommodate additional field devices, such as solenoid valves, to eliminate the cost of any additional junction boxes.
6. Each UltraSwitch™ enclosure includes a **Detailed Wiring Diagram** permanently attached inside the cover.
7. **Internal Grounding Screw** for ground wire hookup.
8. **Internal Potting Wells.** Within the housing at the conduit entries are two potting wells available for factory sealed leads. They may be filled with conduit potting compound or RTV silicone sealant to prevent the entrance of corrosive vapors or fluids.

Flowserve Corporation  
Flow Control Division  
www.flowserve.com

1350 N. Mountain Springs Parkway  
Springville, Utah 84663-3004  
Phone: 801 489 8611

1978 Foreman Dr.  
Cookeville, TN 38501  
Phone: 931 432 4021

### Materials of Construction:

Part	Materials
Housing/Cover	DuPont Zytel® GFN33G
Shaft	Stainless Steel
Cams/Splines	Nylon
Pharos Dome and Rotor	Polycarbonate
Terminal Block	Nylon - Buchanan TBS Series
Internal Brackets	Stainless Steel or Plated Steel
All Internal Fasteners	Stainless Steel or Plated Steel
All External Fasteners	Stainless Steel
Threaded Inserts	Nickel-Plated Brass

### Dimensions:

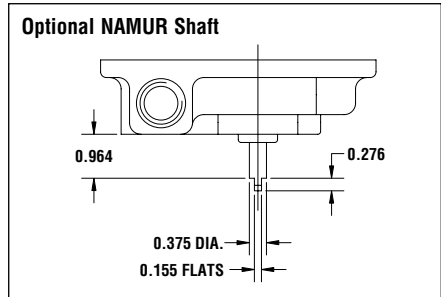
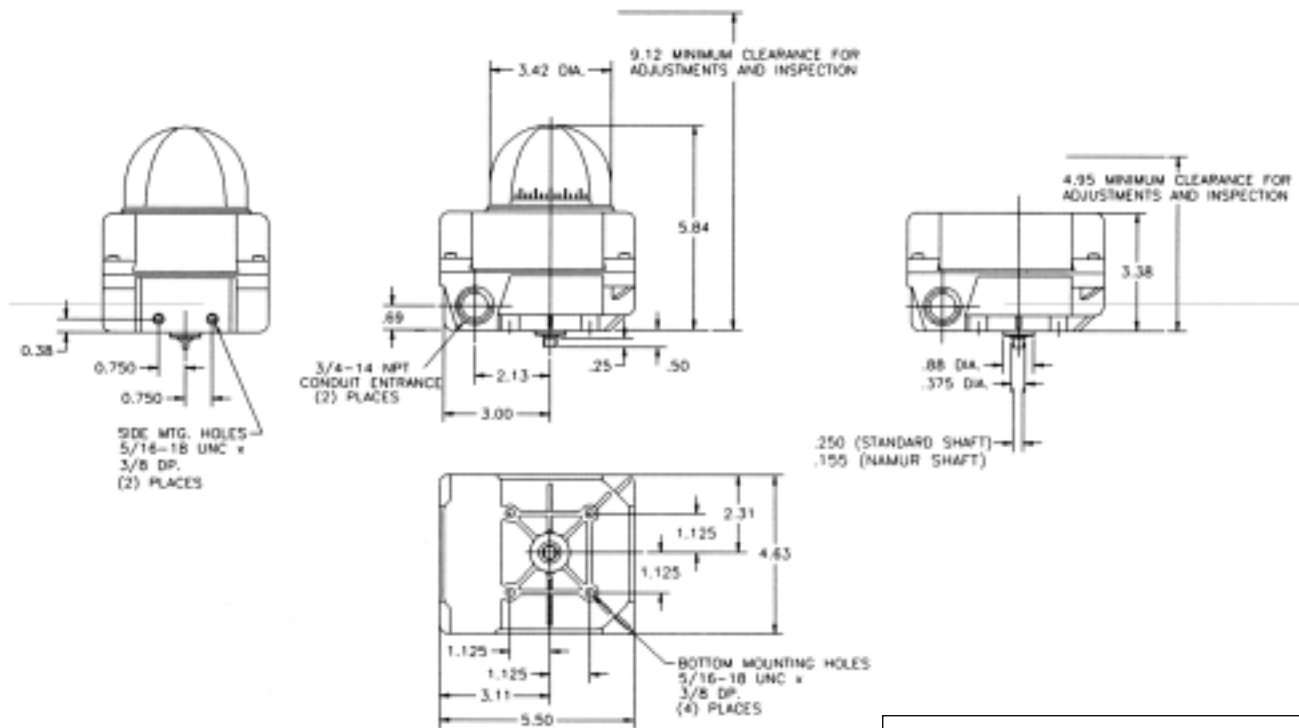

Flowserve Corporation  
Flow Control Division  
www.flowserve.com

1350 N. Mountain Springs Parkway  
Springville, Utah 84663-3004  
Phone: 801 489 8611

1978 Foreman Dr.  
Cookeville, TN 38501  
Phone: 931 432 4021

**Principles of Operation:**

The PL series UltraSwitch™ is designed for use with any industrial rotary actuator in hazardous locations. It indicates open and closed valve positions by completing electrical circuits to remote locations. The PL series may include an analog feedback device (see bulletin PS0050-CV) to indicate continuous position for modulating packages. Local visual indication is accomplished with the Pharos™ Rotary Indicator.

**Hazardous Location Approvals:****Mechanical Switches****Types 1, 2 and 3**

No hazardous location approval

**Proximity Switches****Types 4, 5, 6, all Phazer, R & U**

Class 1, Groups A, B, C & D,  
Division 2 only

***Note:** When using hermetically sealed proximity switches, a conduit seal is not required (Division 2 only).*

**Temperature Range:**

-40 to 180 Deg. F

-40 to 250 Deg F: Consult Factory

**Agency Listings:**

U.L. File No. E122717

C.S.A. File No. LR 83687

**Representative:**