

FLowsERVE[®]

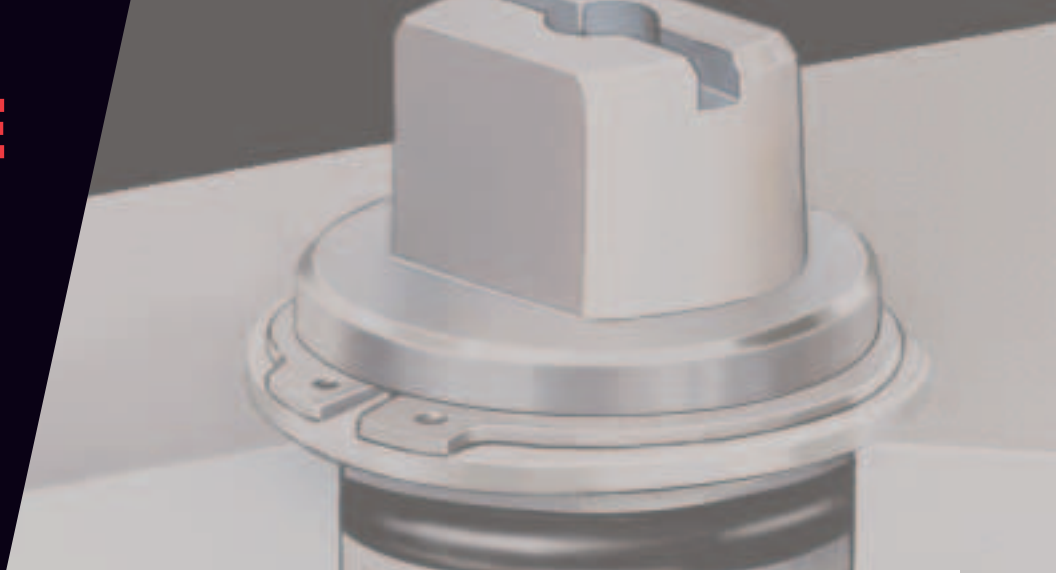

Automax Valve Automation Systems
Pneumatic Actuators And Accessories



Flowserve is the World's Premier Provider of flow management services. Flowserve manufactures Automax Valve Automation Systems to provide full service valve and damper automation to the worldwide oil and gas, pulp and paper, chemical, processing and energy related industries. We provide maximum value to the end user through a broad offering of products, services, application engineering and our systematic approach to automation.

Sales and service facilities are strategically located in industrial centers throughout the world.

Automax Valve Automation Systems
Springville, Utah; Cookeville, Tennessee; and Lynchburg, Virginia

Web Site: <http://www.flowserve.com> **Email:** actuators@flowserve.com



Quality, Dependability, and Productivity.

Recognized as the leader in valve automation systems, Automax’s pneumatic actuators can automate valves with torque values from 25 to 500,000 in-lb. Actuators are available in a wide range of materials suitable for use in the most demanding applications. Flowserve also offers a comprehensive range of NAMUR Controls and accessories such as lockout modules and gear overrides. To complete the package Flowserve can provide engineering design services for AutoBrakit Mounting hardware. We currently have more than 10,000 AutoBrakits designed and documented for traceability and repeatability on a global basis.

**SuperNova
B-Series**



SuperNova B series Rack and Pinion actuators are designed for butterfly, plug or ball valves, and offer one compact design for double acting and spring return. Precision die-cast pistons with large cylinder bearings increase efficiency and cycle life. Available in torque ranges from 25 in-lb to 58,000 in-lb, for optimum actuator sizing.

Page 4-7

**Controls &
Accessories**

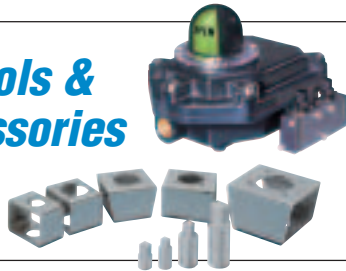

The actuator is the heart of an automation system, but control accessories are important in creating a complete system to meet increasingly sophisticated customer requirements. Solenoid valves and related accessories with NAMUR interfaces provide direct, modular mounting on actuator. Switches, Positioners, Gear Overrides and Lockout Modules can also be integrated into the assembly. AutoBrakits are engineered to assure consistency and proper alignment.

Page 9

**Stainless Steel
SXL-Series**



The SXL® series utilizes a 316 series stainless steel housing and is ideal for use in corrosive environments. It is available in both double acting and spring return and can be supplied with internal components identical to the SNA Series or with optional stainless steel internals. For sanitary applications the housing can be polished. Available in torque ranges from 78 in-lb to 7279 in-lb.

Page 10-11

**EFC
Epoxy-Filled
Composite Series**

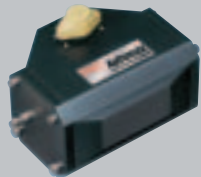

The EFC series actuator is manufactured from a combination of tough corrosion resistant epoxy and composite materials. The simple design of the EFC series ensures the minimum number of moving parts and seals. Double acting and spring return versions utilize a shuttle piston with a full diameter acetal bearing.

Page 12-13

**Heavy Duty
R2, R3, R4
& R5 Series**

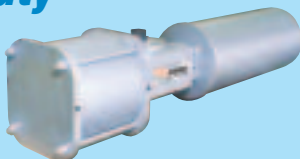

A complete line of Scotch Yoke heavy-duty actuators provides torques from 3,000 to 500,000 in-lb. The combination of Scotch Yoke actuators plus Rack and Pinion actuators offers the opportunity to standardize on one source for your complete quarter-turn automation needs. Scotch Yoke Actuators can also be configured with high pressure hydraulic cylinders. Contact Flowserve for complete details.

Page 14-19

SuperNova B-Series

Double Acting

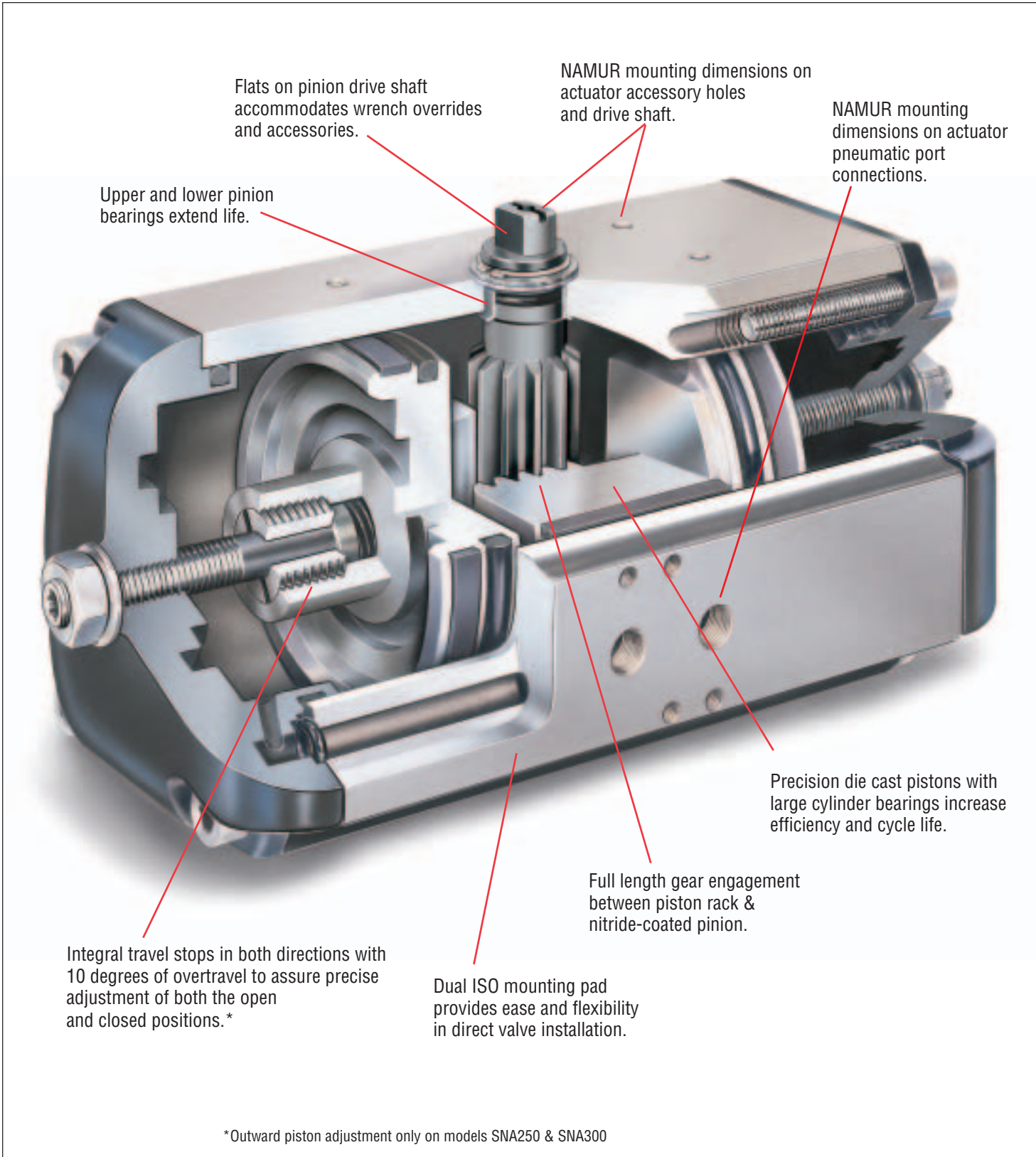

Flats on pinion drive shaft accommodates wrench overrides and accessories.

NAMUR mounting dimensions on actuator accessory holes and drive shaft.

NAMUR mounting dimensions on actuator pneumatic port connections.

Upper and lower pinion bearings extend life.

Precision die cast pistons with large cylinder bearings increase efficiency and cycle life.

Full length gear engagement between piston rack & nitride-coated pinion.

Integral travel stops in both directions with 10 degrees of overtravel to assure precise adjustment of both the open and closed positions.*

Dual ISO mounting pad provides ease and flexibility in direct valve installation.

*Outward piston adjustment only on models SNA250 & SNA300



Spring Return

Broad size range offers optimum actuator sizing for each valve requirement.

One compact design for double acting and spring return is easily field convertible by installing or removing springs.

Field reversible action simply by rotating pistons 180°.

Rack & Pinion Actuators are designed for automating butterfly, plug or ball valves and dampers. The actuators incorporate a precision-extruded hard anodized aluminum body and a one-piece nitride-coated pinion gear, factory lubricated for a long trouble-free life. Actuators are designed for 100-degree travel with clockwise and counterclockwise travel adjustment for open and closed positions.

Automax Aluminum Alloy

Hard anodic oxidation is an electrolytic conversion process which results in the formation of an oxide film. Continuation of the process produces the “hard” anodic coating to two mils. The chemical composition provides the optimum alloy for strength, abrasion resistance, cold working and chemical resistance.

The most useful properties of the oxide coating are:

1. The oxide coating is integral with the base substrate and will not spall off by impacting thermal shock nor to temperatures to aluminum’s melting point. The oxide has negligible effect on the other properties of aluminum.
2. Aluminum oxide is one of the hardest materials known with a hardness of corundum (45 to 65 Rockwell C). Further, abrasion tests show only half as much wear as hardened steel.
3. Aluminum oxide is relatively stable and chemically inert. The oxide is usually stable over a pH range of 4.5 to 8.5, but can be dissolved by strong acids and alkalis, where as it normally resists concentrated nitric acid at pH 1 and ammonium hydroxide at pH 13.

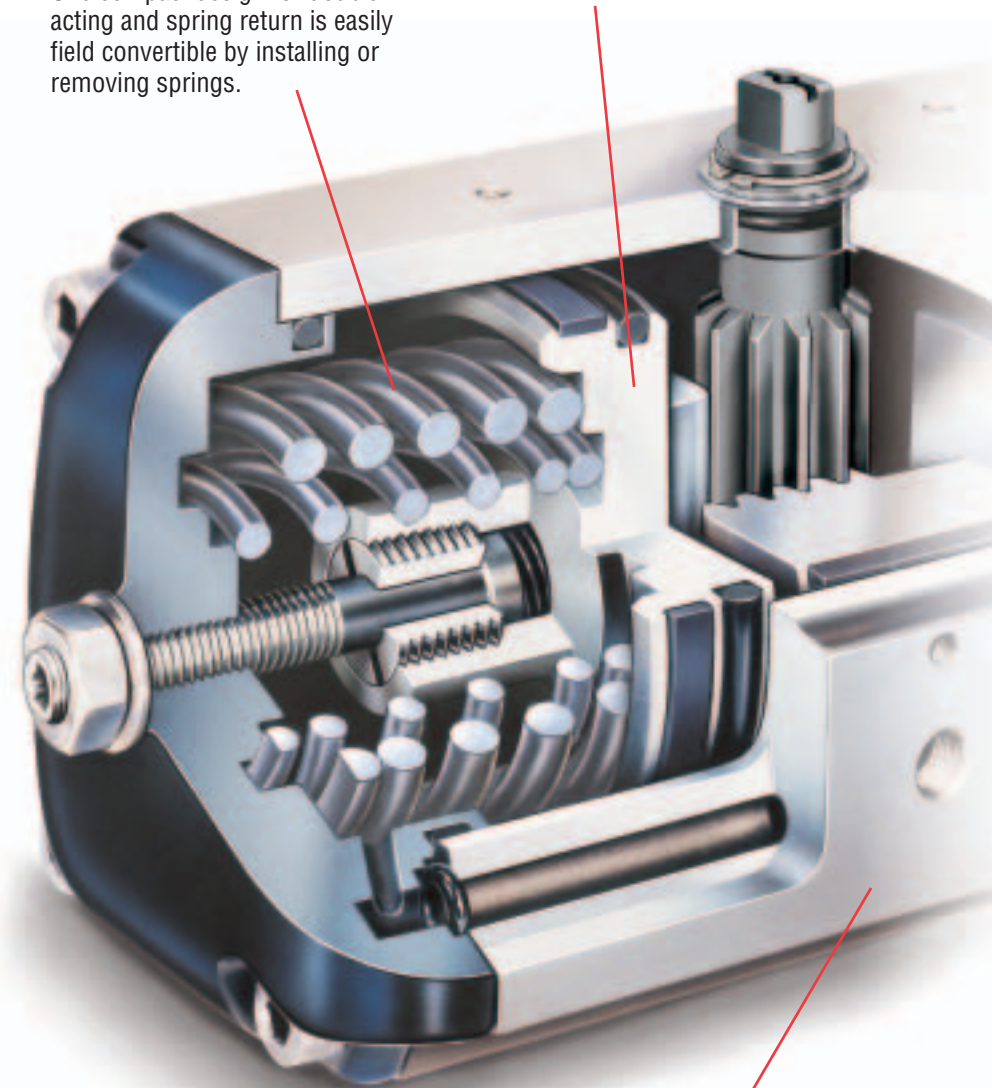

Corrosion resistant hard anodized aluminum housings with stainless steel fasteners.

SuperNova B-Series

Torque Outputs

Model	Spring			Air Supply					
	No	End	Break	60 Psi		80 Psi		100 Psi	
				End	Break	End	Break	End	Break
B050	5	36	55	56	76				
	6	43	64	46	69				
	7	49	73	35	63	74	102		
	8	61	92	15	49	54	88	93	127
	9	73	110			34	74	73	113
B063	6	68	102	103	141				
	7	79	119	85	128				
	8	90	136	66	116				
	9	102	153			119	175		
	10	113	170			100	163		
B085	6	141	211	215	293				
	7	164	246	177	267				
	8	188	282	138	241				
	9	211	317			248	365		
	10	235	352			209	339		
B100	6	260	390	397	541				
	7	303	455	325	493				
	8	347	520	253	445				
	9	390	585			457	673		
	10	433	651			385	625		
B115	6	430	645	656	894				
	7	502	753	537	814				
	8	573	860	418	735				
	9	645	968			756	1112		
	10	717	1075			637	1033		
B125	6	610	915	930	1267				
	7	712	1067	761	1155				
	8	813	1220	593	1042				
	9	915	1372			1071	1577		
	10	1017	1525			903	1464		
B150	11	1118	1677			734	1352	1381	1999
	12	1220	1830					1213	1887

Note: For additional air supply pressures, consult factory or your AutoSize software program.

Actuator	DA Torque				
	Air Pressure (psi)				
	40	60	80	100	150
A32	25	37	50	62	93
B050	78	116	155	194	291
B063	144	216	288	360	539
B085	299	449	598	748	1122
B100	552	828	1104	1380	2071
B115	913	1369	1826	2282	3423
B125	1294	1941	2588	3236	4853
B150	2329	3494	4658	5823	8734
B175	3487	5230	6974	8717	13076
B200	4970	7455	9940	12424	18637
SNA250	10354	15531	20707	25884	38826
SNA300	15529	23293	31057	38822	58232

Model	Spring			Air Supply					
	No	End	Break	60 Psi		80 Psi		100 Psi	
				End	Break	End	Break	End	Break
B150	6	1098	1648	1673	2280				
	7	1281	1922	1369	2078				
	8	1465	2197	1066	1875				
	9	1648	2471			1927	2837		
	10	1831	2746			1624	2635		
B175	6	1606	2527	2438	3457				
	7	1899	2907	2079	3133				
	8	2153	3349	1530	2851				
	9	2427	3759			2820	4292		
	10	2701	4170			2366	3989		
B200	6	2343	3516	3568	4864				
	7	2734	4107	2914	4432				
	8	3125	4691	2269	4000				
	9	3515	5277			4106	6053		
	10	3906	5865			3456	5622		
SNA250	6	2854	6591	7421	12025				
	7	3393	7690	6448	11441				
	8	3945	8788	5428	10857				
	9	4519	9887	4373	10273	9780	15450		
	10	5106	10985	3274	9689	8566	14866		
SNA300	6	4744	11096	9931	17473				
	7	5640	12945	8245	16501				
	8	6558	14795	6482	15530				
	9	7512	16644	4658	14559	12669	22326		
	10	8487	18493	2762	13588	10625	21355		
SNA250-SNA300	11	9500	20343			8581	20384	16348	28150
	12	10543	22192			6537	19412	14304	27179

Spring Chart B050 ②

Spring Group	Spring Combination ①		
	#1 Spring (inner)	#2 Spring (low rate outer)	#3 Spring (high rate outer)
4	1 ③	1 ③	
5		2	
6	2	1	
7	1	2	
8	2	2	
9	2		2

Note: ① #1 Spring has one color code dot
 #2 Spring has two color code dots
 #3 Spring has three color code dots
 ② B050 has maximum of 2 springs per endcap
 ③ Install springs on opposite sides

Spring Chart B063-B200

Spring Group	Spring Combination ①		
	#1 Spring (inner)	#2 Spring (middle)	#3 Spring (outer)
4		2	
5		1 ③	1 ③
6			2
7	1		2
8	2		2
9	1 ③	1 ③	2
10		2	2
11	1	2	2
12	2	2	2

SNA250-SNA300 Spring Combinations

Spring number is total number of springs in endcaps. There should never be a difference in springs per endcap greater than one. Example: SNA250S09 would have four springs in one endcap and five in the other.

Dimensions

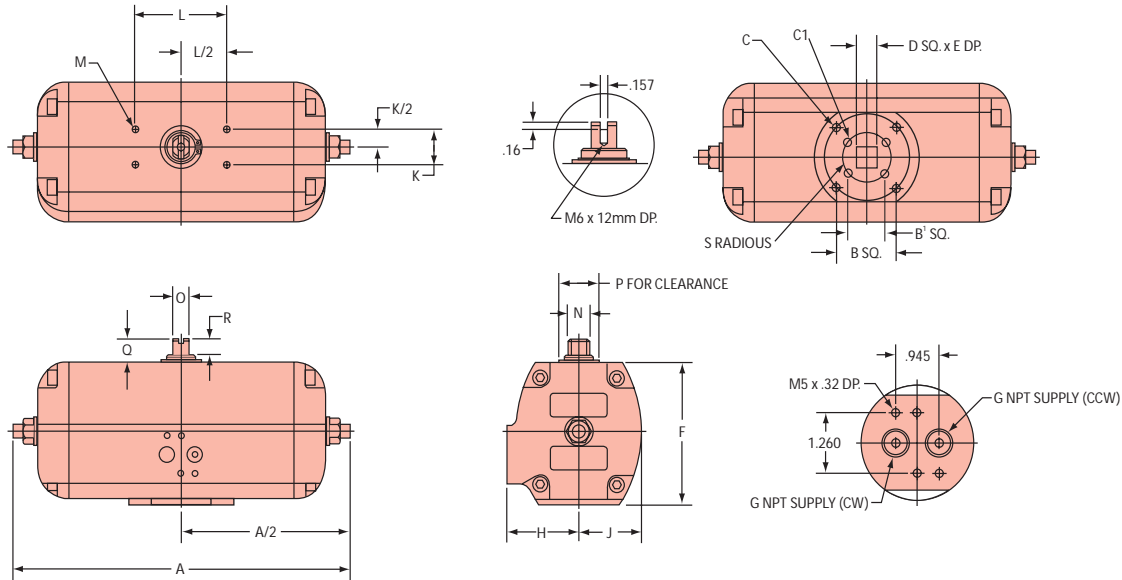

- ① Actuator shown in the full clockwise (CW) position as viewed from top.
 ② Accessory mounting holes not for gear override or stop block.
 ③ Cycle times under no load conditions. Air line size, air capacity, and valve torque characteristics affect these cycle times. Faster or slower cycle times can be accomplished using special control components.

Model	ISO	A		B SQ.	B' SQ.	C	C'	D	E	F	G NPT	H	J	K	L	M②③	N	O	P	Q	R	Weights (lbs)		Volume (in)		Cycle Time		
		DA&SR	180																			DA	SR	CW	CCW	CW	CCW	.5
B050	F04S11E	6.69	8.70	1.169	N/A	#10-24x.31	N/A	.433	.47	2.56	1/8	1.58	1.14	1.181	3.150	#10-24	.47	.394	.75	.79	.39	.39	2.7	3.1	8.2	5.4	.5	.5
B063	F03/F05S14E	7.95	9.92	1.392	1.002	1/4-20x.31	#10-24x.31	.551	.63	3.19	1/8	1.77	1.40	1.181	3.150	#10-24	.47	.394	.88	.79	.39	.39	3.8	4.4	16	10	.5	.5
B085	F05/F07S17E	9.84	12.13	1.949	1.392	5/16-18x.31	1/4-20x.31	.669	.75	4.15	1/8	2.24	1.87	1.181	3.150	#10-24	.77	.551	1.00	.79	.55	.55	7.5	9.3	34	20	.5	.5
B100	F05/F07S17E	11.65	14.80	1.949	1.392	5/16-18x.31	1/4-20x.31	.669	.75	4.80	1/4	2.48	2.17	1.181	3.150	#10-24	.77	.551	1.38	.79	.55	.55	11.5	14.6	56	38	1	.5
B115	F07/F10S22E	13.47	17.60	2.840	1.949	3/8-16x.39	5/16-18x.31	.866	.98	5.30	1/4	2.91	2.46	1.181	5.118	#10-24	1.10	.787	1.63	1.18	.79	.79	17.7	22.5	94	65	1	1
B125	F07/F10S22E	15.83	20.35	2.840	1.949	3/8-16x.39	5/16-18x.31	.866	.98	5.79	1/4	3.07	2.68	1.181	5.118	#10-24	1.10	.787	2.00	1.18	.79	.79	23.8	30.2	128	90	1	1
B150	F10/F12S27E	19.13	25.20	3.480	2.840	1/2-13x.45	3/8-16x.39	1.063	1.18	6.85	1/4	3.47	3.19	1.181	5.118	#10-24	1.87	1.417	2.38	1.18	.89	.89	40.8	51.2	224	159	2.0	1.5
B175	F10/F14S36E	21.34	28.58	3.897	2.840	5/8-11x.63	3/8-16x.39	1.417	1.57	8.21	1/4	4.17	3.74	1.181	5.118	#10-24	1.87	1.417	2.75	1.18	.89	.89	63.7	77.2	351	232	3.0	2.0
B200	F10/F14S36E	24.41	31.69	3.897	2.840	5/8-11x.63	3/8-16x.39	1.417	1.57	9.39	1/4	4.72	4.25	1.181	5.118	#10-24	1.97	1.417	2.94	1.18	.89	.89	91.5	118	507	332	4.5	3.0

Note: Double Acting
 Pressure at port "CW" will result in clockwise rotation. Pressure at port "CCW" will result in counter-clockwise rotation.
 Note: Spring Return
 Pressure at port "CCW" will result in counterclockwise rotation. Springs provide clockwise rotation upon loss of pressure.

How To Order (Select Bold Type Code from each column that applies)

MODEL	TYPE	Springs (Select One)①		Seals	Materials	Options
		050 Thru 300				
B050	D Double Acting	04		Blank - Buna (Std.)	Blank - Std. Hard Anodized	R Extra Long Travel Stop
B063	S Spring Return (FCW)	05		L Low Temp.	Aluminum	C Stainless Steel Pinion/Snap Ring
B085	C Spring Return (FCCW)	06		H Viton (High Temp.)	K K-Mass Coated	
B100	M 180° Double Acting	07			W White Epoxy Coated	
B115		08			G Gray Epoxy Coated	
B125		09			X BlackMax Coating	
B150		10				
B175		11				
B200		12				
SNA250						
SNA300						

①Consult torque charts or AutoSize for applicable spring combinations.
 Example: A model B100 spring return (FCW) spring set 10, would be coded as **B100S10**

SuperNova Models SNA250 & SNA300 90° Units and 180° Actuators

SNA250



Typical 180° Rotary Actuator

180° Rack & Pinion Actuators

Automax 180 Degree Actuators are available in the same models and with the same torque outputs as the standard SuperNova Double Acting actuators. The integral mechanical, end-of-stroke travel adjustment is for one direction only. As options, travel stops can be furnished for less than 180° travel and an additional travel stop for the other direction can be provided in the valve actuator adaption.

Automax has developed economical control circuits and devices to actuate multiport valves both
 2 position (0°, 180°) and
 3 position (0°, 90°, 180°)
 utilizing the UltraSwitch. Consult your Automax Representative for assistance in selecting the best control package.

Dimensions for 50-200 size 180° actuators on previous page.

Dimensions

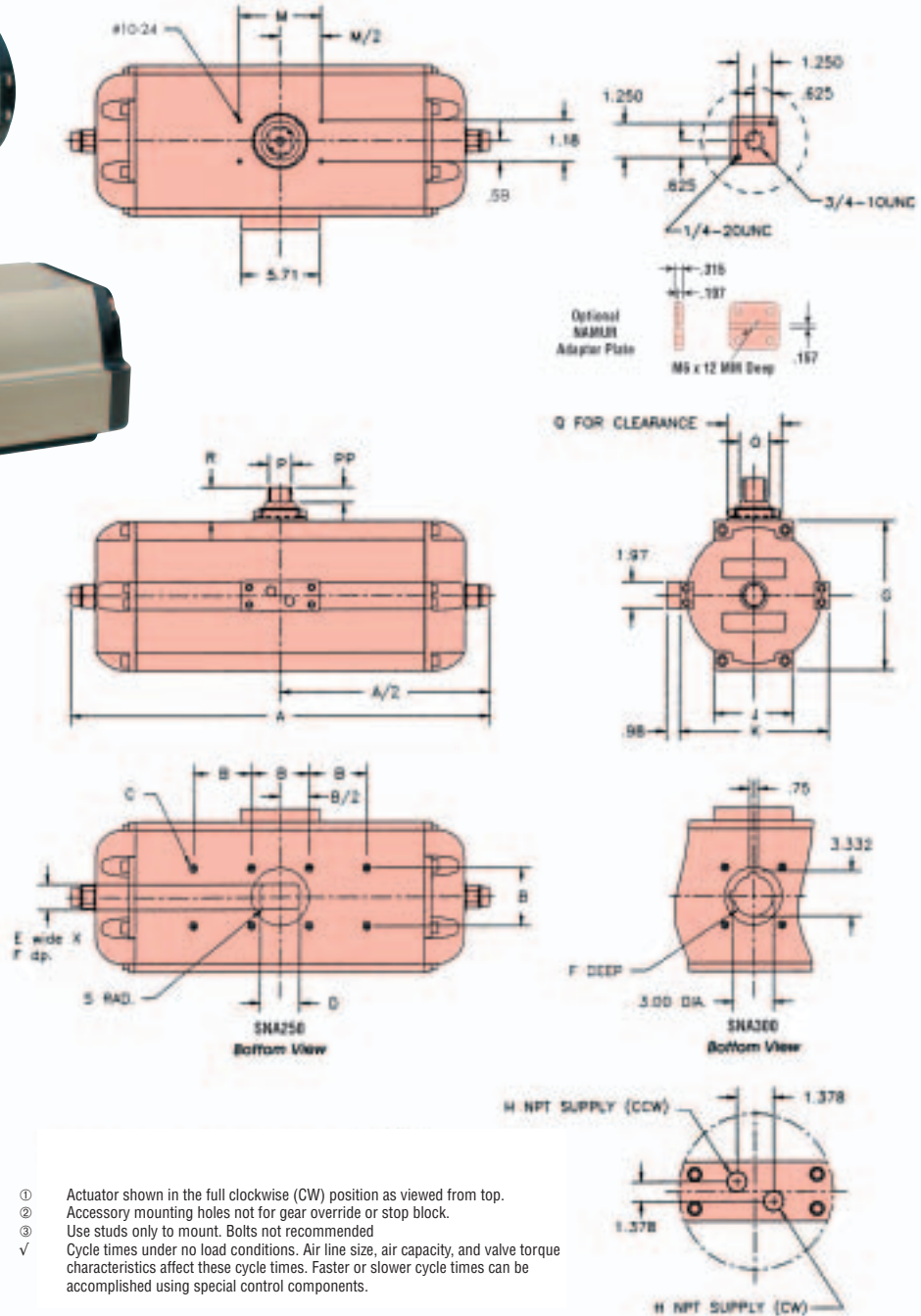

MODEL	A		B	C	D	E	F	G	H	J	K	M	O	P	PP	Q	R	S	WEIGHTS		VOLUME		CYCLE TIME	
	DA&SR	180																	DA	SR	CW	CCW	CW	CCW
SNA250	27.32	39.14	4.250	5/8-11X.63	2.87	1.850	1.81	11.02	1/2	5.91	11.02	5.118	2.20	1.969	0.98	3.75	1.65	.24	137	172	757	720	5-7	5-7
SNA300	32.60	44.00	5.000	5/8-11X.94	N/A	N/A	2.50	13.39	1/2	6.30	13.39	5.118	2.44	1.969	0.98	3.75	1.65	N/A	217	288	1403	1019	6-9	6-9

For "How To Order" see page 7

Controls



A25N Directional Valve*

The Automax Directional Valve mounts directly to SuperNova series actuators which eliminates the cost of tubing and fittings. The valves are available for double acting and spring return actuators with NEMA 4X, 7 & 9, or intrinsically-safe and low power solenoid operators. These valves have been tested and proven reliable for over 1 million cycles.



APS1 Module*

The Automax APS1 module works with the Automax A25N solenoid valve and diverts exhaust air from between the pistons into the spring chamber. This prevents corrosive atmospheres from being pulled into the spring chamber.



APS2 Module*

The Automax APS2 module works with remote/line mounted solenoid valves and diverts exhaust air from between the pistons into the spring chamber. This prevents corrosive atmospheres from being pulled into the spring chamber.



LV1 Lockout & Vent Valve*

The LV1 Lockout and Vent Valve module provides two primary functions. The LV1 may be used with a manual override to shut off supply air and vent actuator ports. The LV1 may also be used as a pneumatic lockout valve which, when properly implemented, will satisfy OSHA Standard 1910.47. The LV1 may be sandwich mounted with other Automax NAMUR accessories or may be used with the NPT1 adaptor.



FC1, FCDA & FCSR*

The 'FC' Series Flow Control modules provide compact flow controls for precise adjustment of SuperNova actuator speeds. The Flow Control Modules may be sandwich mounted with other Automax accessories or may be used with the NPT1 adaptor.

Accessories



"Pharos" NAMUR Indicator*

Provides an economical solution for positive visual indication of the actuator position. Constructed of tough industrial engineered resin, the UltraIndicator can be used on actuators that utilize a NAMUR mounting interface.



UltraSwitch GL/XL/PL Series Rotary Position Indicators*

The UltraSwitch series of position indicators provides a compact and economical package for both visual and remote electrical indication of valve position. Models are available in both die cast aluminum and non-metallic versions. Suitable for non-hazardous, hazardous and intrinsically-safe applications.



Aviator and BUSwitch Rotary Position Indicator with Internal Pilot Solenoid*

The Aviator rotary position indicator enclosure with internal pilot solenoid coil provides a truly integrated package. It can easily be converted to a BUSwitch by simply adding a Fieldbus communication printed circuit board.



APEX Modular Positioner*

Available in both aluminum and non-metallic versions, the Apex positioner combines precise valve positioning with advanced features. A modular manifold base allows 3-15 psi pneumatic control signals, or 4-20mA signals with the addition of the I/P module. Models are available for corrosion resistant applications and hazardous locations as defined by UL, C-UL, CENELEC, and SAA.



Lockouts*

The lockout option permits easy lockout of automated valves. Lockouts are designed to withstand the rated output torque of the actuator, with the intent to meet the requirements of OSHA Standard 1910.47 "The Control of Hazardous Energy" (Lockout/Tagout.)



Gear Overrides*

Declutchable gear overrides are options which allow local manual control of actuated valves and dampers. The gear overrides are sized for easy operation and can be combined with other control accessories.



AutoBrakits*

Automax heavy-duty mounting kits are designed to close tolerances to assure consistency and proper alignment, which are essential to ensure maximum actuator and valve cycle life.

* Consult Individual Catalogs and IOM's For Additional Information

SXL Series Stainless Steel

The SXL Series utilizes a 316 series stainless steel body and is ideal for use in corrosive environments. It is available in both Double Acting and Spring Return versions with a maximum double acting torque output of 7,279 in-lbs. The SXL Series can be supplied with stainless steel or aluminum pistons and springs per customer requirements and is also available with optional polished finishes for sanitary applications.

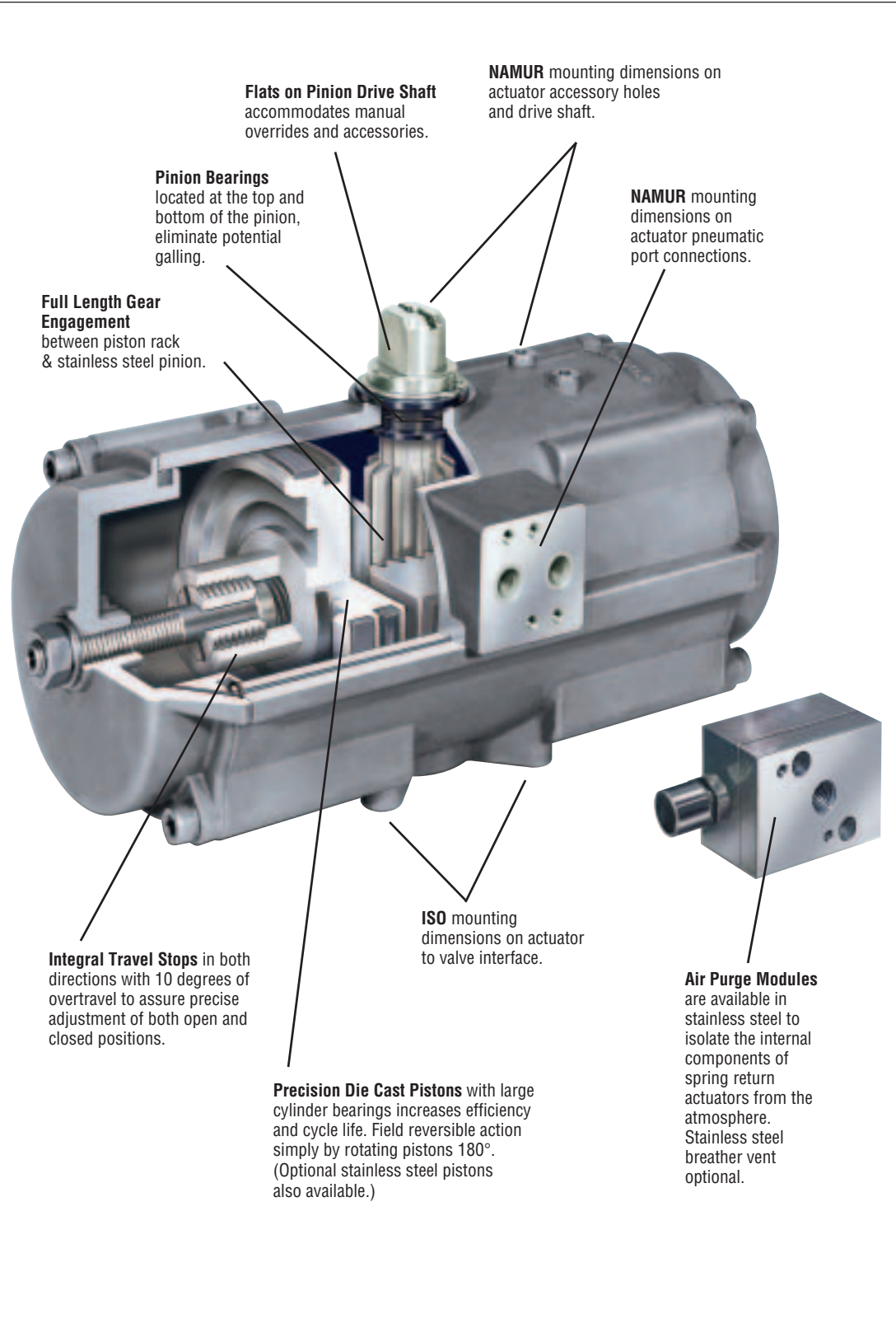

SXL Series Dimensions

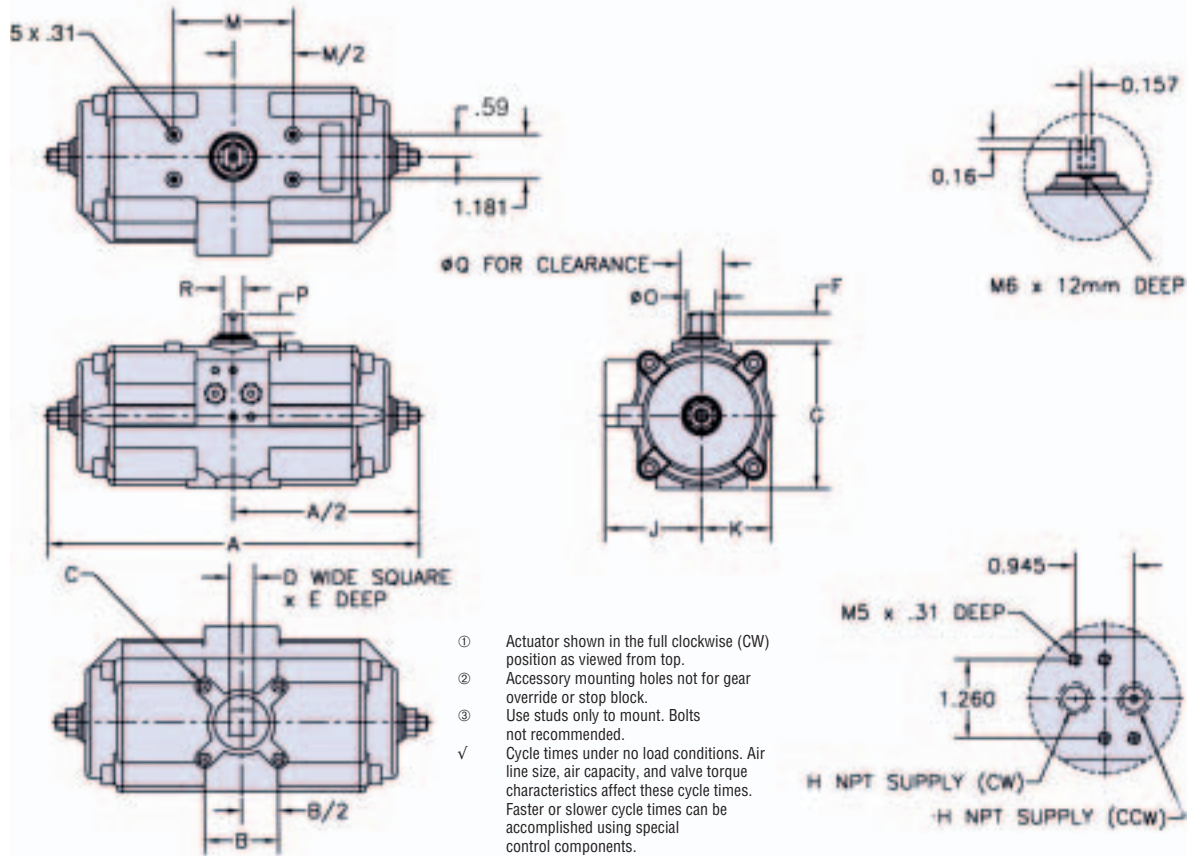

Model	ISO	A	B	C	D	E	F	G	H	J	K	M	O	P	Q	R	WEIGHTS		VOLUME		CYCLE TIME	
																	DA	SR	CW	CCW	CW	CCW
SXL050	FO4S11M	6.69	1.169	M5 x .31	.433	.47	.79	2.56	1/8	1.85	1.18	3.150	.56	.39	.83	.39	4.85	5.15	8.2	5.4	.5	.5
SXL063	FO5S14M	7.95	1.392	M6 x .31	.551	.63	.79	2.56	1/8	2.11	1.44	3.150	.56	.39	.91	.39	7.05	7.80	16	10	.5	.5
SXL085	FO7S17M	9.84	1.949	M8 x .31	.669	.79	.79	3.94	1/8	2.60	1.87	3.150	.77	.55	1.18	.55	11.24	13.18	34	20	.5	.5
SXL100	FO7S17M	11.65	1.949	M8 x .31	.669	.79	.79	4.57	1/4	2.95	2.	3.150	.77	.55	1.46	.55	16.09	19.02	56	38	1	.5
SXL115	F10S22M	13.46	2.840	M10 x .31	.866	.98	1.18	5.16	1/4	3.23	2.46	5.118	1.38	.79	1.77	.79	23.14	27.55	94	65	1	1
SXL125	F10S22M	15.83	2.840	M10 x .31	.866	.98	1.18	6.61	1/4	3.43	2.70	5.118	1.38	.79	2.17	.79	38.14	45.12	128	90	1	1
SXL150	F12S27M	19.13	3.480	M12 x .47	1.063	1.14	1.18	6.61	1/4	3.94	3.19	5.118	1.97	.89	2.64	1.42	51.14	61.50	224	159	2	1.5

How To Order (Select Bold Type Code from each column that applies)

Model	Type	Springs (Select One)	Seals	Materials	Options
SXL050	D Double Acting	04	Blank - Viton (Std.)	Blank	R Extra Long Travel Stop
SXL063	S Spring Return (FCW)	05	L Low Temp.	K K-Mass Coated	M Stainless Steel Springs
SXL085	C Spring Return (FCCW)	06		F Polished	P Stainless Steel Pistons
SXL100		07			
SXL115		08			
SXL125		09			
SXL150		10			
		11			
		12			

Example: A model SXL100 spring return (FCW) spring set 10, would be coded as **SXL100S10**

EFC Series Actuators

The EFC Series Actuator is manufactured from a tough corrosion-resistant epoxy and glass composite (EFC) which does not require surface protection. EFC is a tough material, which is consistent throughout, therefore any surface damage will not affect its resistance to corrosion.

The EFC Series shuttle piston design allows ample space for two low-fatigue spring cartridge packs, located within the full length of the piston. For a double-acting actuator, the spring cartridge packs are removed, thus avoiding a dimensional difference between spring return and double-acting version.

The simple design of the EFC Series Actuator ensures the least number of moving parts and air seals. The shuttle piston has full diameter acetal bearing rings and nitrile 'O' rings located at each end of the piston. Both bearing rings and 'O' rings can be changed simply by removing the end caps. Total disassembly of the actuator is not necessary and, therefore, maintenance costs are reduced.

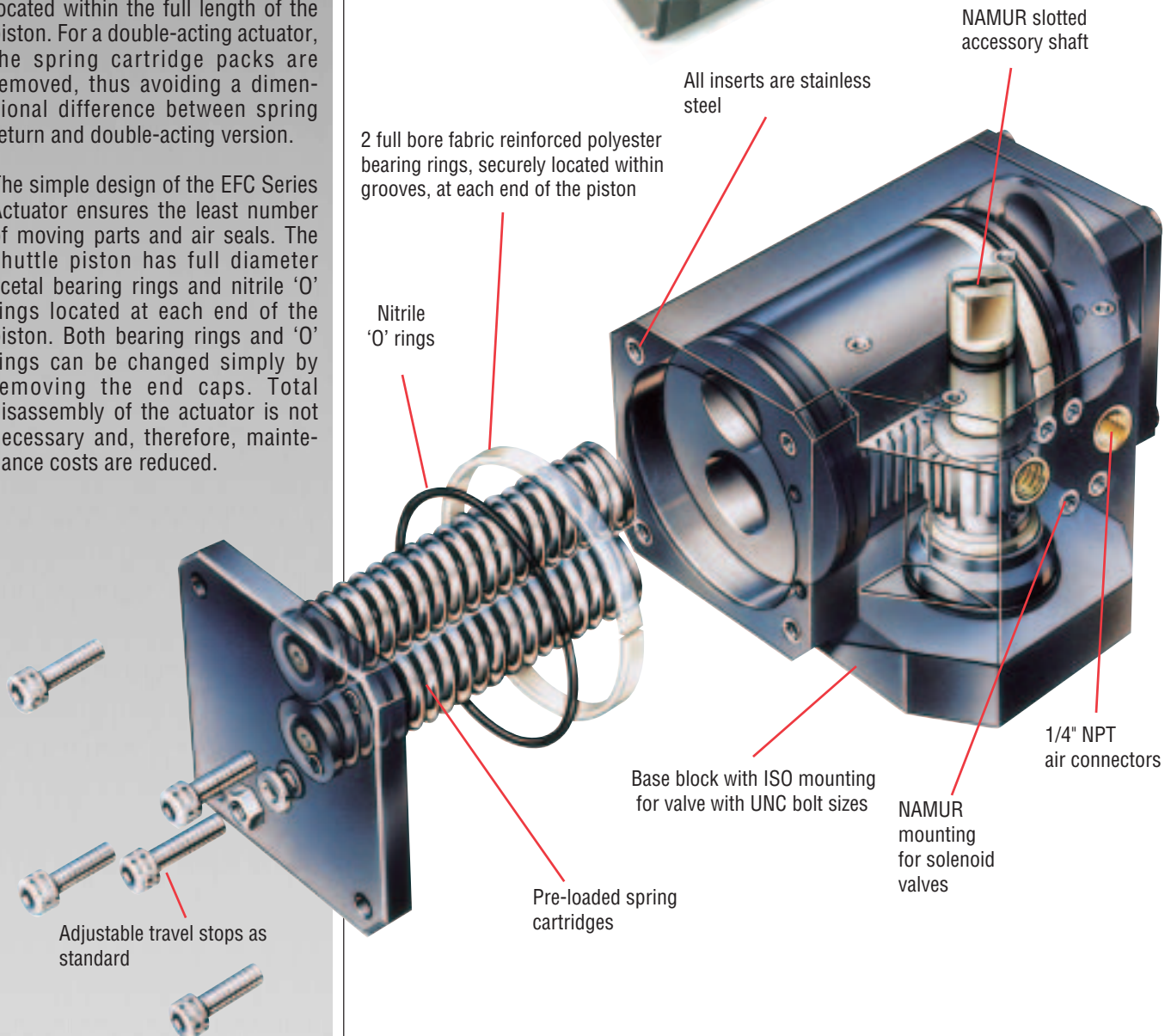
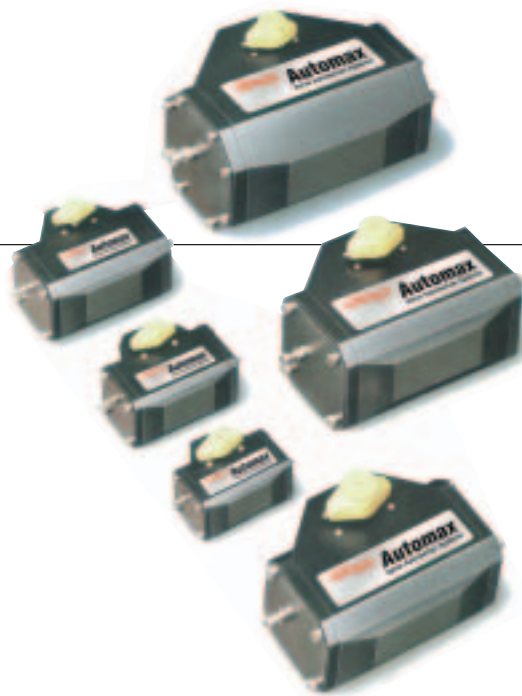

EFC Series Dimensions

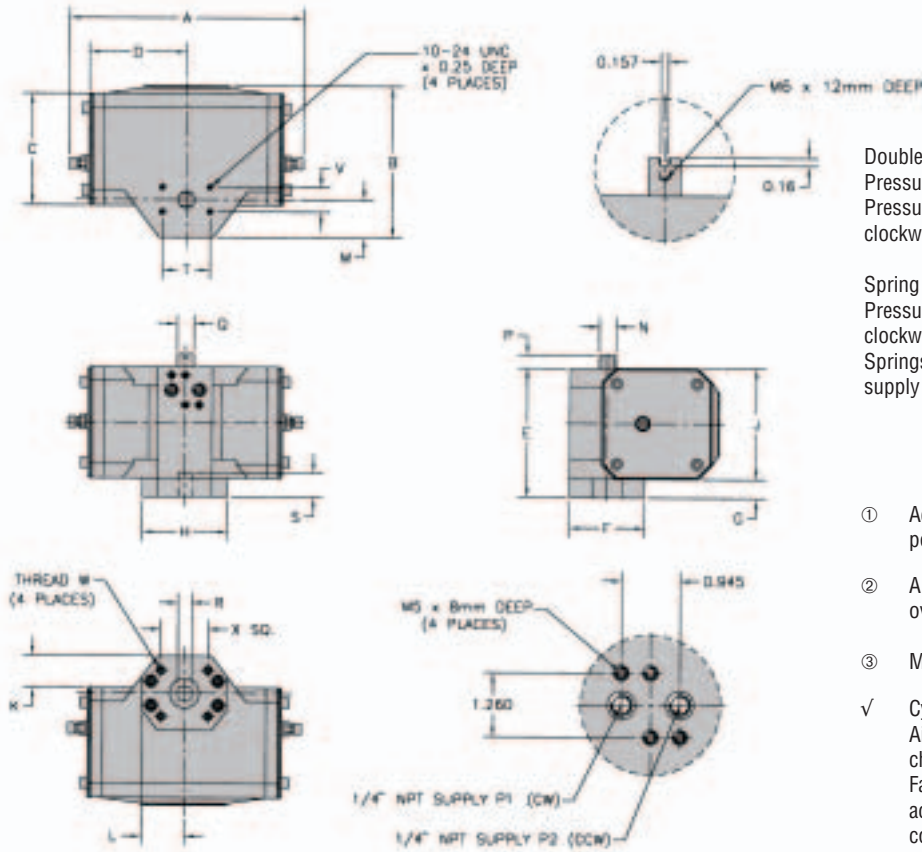

Double Acting (as viewed from top)
Pressure at port "P1" will result in clockwise rotation.
Pressure at port "P2" will result in counter-clockwise rotation.

Spring Return (SR Unit) (as viewed from top)
Pressure at port "P2" will result in counter-clockwise rotation.
Springs provide clockwise rotation upon loss of supply pressure.

- ① Actuator shown in the full clockwise (CW) position as viewed from top.
- ② Accessory mounting holes not for gear override or stop block.
- ③ Mounting is per ISO 5211 with UNC bolt sizes.
- ✓ Cycle times under no load conditions. Air line size, air capacity, and valve torque characteristics affect these cycle time. Faster or slower cycle times can be accomplished using special control components.

Model	ISO ③	A	B	C	D	E	F	G	H	J	K	L	M	N DIA.	P	Q	R	S	T②	V	W	X	DA	SR	WEIGHT (lbs)
A20	F04S11E	6.82	4.41	3.15	2.76	3.70	2.68	0.71	2.99	2.95	1.06	1.50	1.34	0.69	0.79	0.472	0.433	0.47	1.969	1.024	1/4-20X.40	1.169	4.6	5.3	
A40	F04S11E	8.36	5.24	3.70	3.31	4.49	2.99	0.79	3.54	3.74	1.34	1.77	1.50	0.69	0.79	0.472	0.433	0.51	1.969	1.024	1/4-20X.40	1.169	7.9	9.0	
A80	F05S14E	9.76	6.30	4.65	4.02	5.47	3.15	0.79	3.54	4.69	1.42	1.77	1.58	0.69	0.79	0.472	0.551	1.02	1.969	1.024	1/4-20X.40	1.392	13	15	
A160	F07S17E	12.57	7.60	5.63	5.16	6.65	3.78	0.98	4.72	5.67	1.65	2.36	1.89	1.06	1.18	0.709	0.669	0.95	3.150	1.181	5/16-18X.50	1.948	22	26	
A270	F10S22E	14.73	8.98	6.65	5.95	7.80	4.41	1.10	5.51	6.65	1.97	2.76	2.21	1.25	1.18	0.866	0.866	1.14	3.150	1.181	3/8-16X.63	2.839	37	44	
A500	F12S27E	17.76	11.02	8.27	7.52	9.33	5.51	1.10	6.23	8.27	2.44	3.15	2.76	1.50	1.18	1.063	1.063	1.34	3.150	1.181	1/2-13X.78	3.479	62	70	

How To Order (Select Bold Type Code from each column that applies)

Model	CYCLE TIME (seconds per 90°)	
	Air	Spring
A20	0.5	0.6
A40	0.6	0.6
A80	0.9	0.6
A160	1.8	1.2
A270	3.2	2.0
A500	4.9	3.3

Model	Type	Springs (select one)	Seals
A20	DA Double Acting	30	Blank Std Buna
A40	SR Spring Return (FCW)	40	
A80	SO Spring Return (FCCW)	50	
A160		60	
A270		70	
A500		80	

Example: A model A80SR spring return (FCW) spring set 60 would be coded as **A80SR60**

Heavy Duty R2, R3 and R4 Series

Automax has a complete line of scotch yoke, heavy duty rotary actuators, which has a unique bearing design to provide higher efficiencies and longer life.

- Pneumatic, Gas and Hydraulic Models
- Double Acting, Spring Return and "Fail-Safe"
- On-Off, Multi-position and Throttling
- Pressure Ranges from 40 psi to 2500 psi
- Torque Outputs: Standard Design from 1000 to 170,000 in-lbs
- Overrides, Special Controls, Line Break Controls, etc.

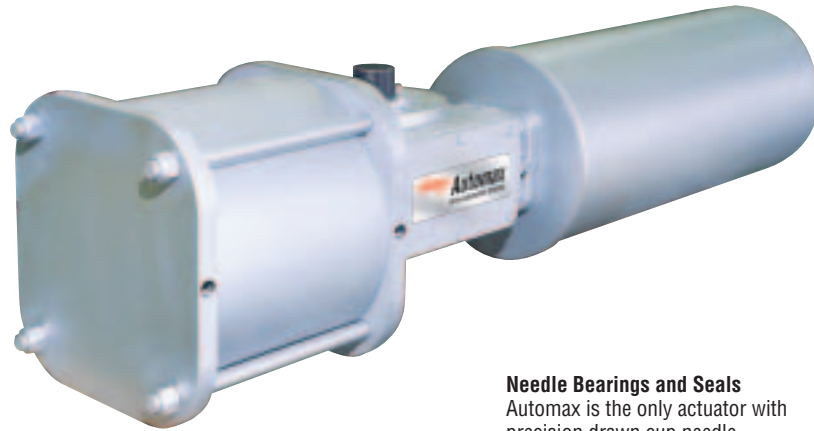

Needle Bearings and Seals
Automax is the only actuator with precision drawn cup needle bearings at the torque shaft journals. The bearings significantly increase torque output and cycle life, while providing near frictionless rotary movement. The seals protect the needle bearings from external dirt and corrosion, while the bearing's rigid design prolongs seal life.

Scotch Yoke
The slot in the scotch yoke mechanism is precision machined. The yoke pin is induction hardened and chrome plated. The yoke pin rollers are hardened steel.

Piston Seals
The pneumatic series actuators utilize a quad seal. This seal has proven dependable in years of trouble-free service.

Spring Module
The spring module is an easily removeable, welded cartridge.

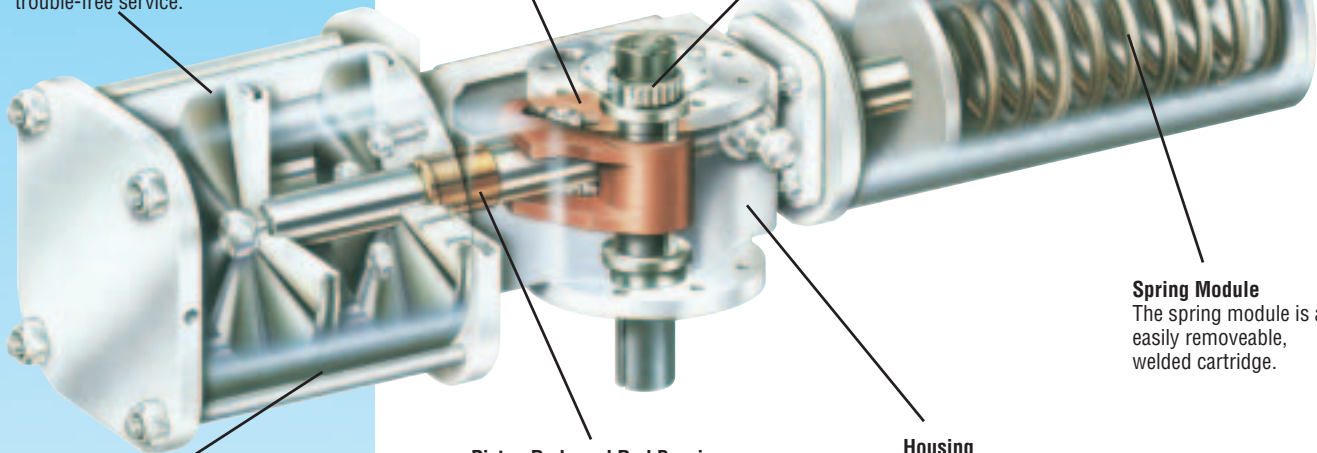

Cylinders
The cylinders are honed to a micro finish with a hard chrome plating.

Piston Rods and Rod Bearings
Large diameter piston rods are guided and supported by extra long bronze bearings. The rods are ground, high strength steel with a hard chrome plating polished to a mirror finish of 4 to 8 microns.

Housing
This unique one-piece housing assures accurate alignment of both the torque shaft and the piston rod.

Heavy Duty R5 Series

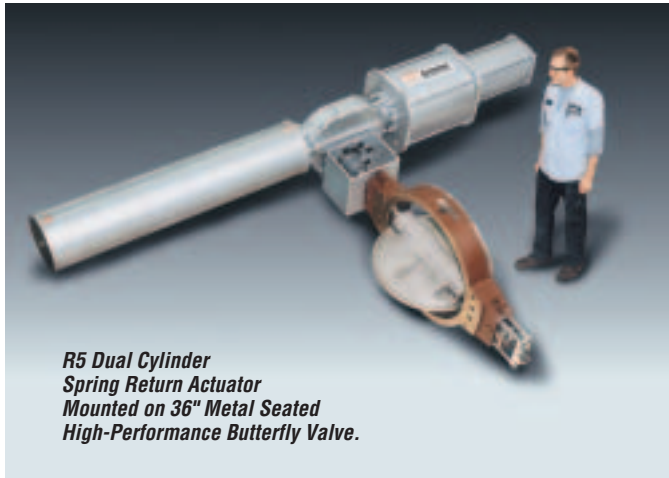

**R5 Dual Cylinder
Spring Return Actuator
Mounted on 36" Metal Seated
High-Performance Butterfly Valve.**

The R5 Series Heavy Duty Scotch Yoke Actuator provides torque output as high as 500,000 in-lb.

- Pneumatic, Gas and Hydraulic Models
- Double Acting, Spring Return and "Fail-Safe"
- On-Off, Multi-position and Throttling
- Pressure Ranges from 40 psi to 2500 psi

The R5 series when combined with Automax's extensive range of automation products offers the opportunity to standardize on a single source for your complete quarter-turn automation needs.

Piston Seal and Wearband

The pneumatic series actuators utilize a quad seal in conjunction with a piston wearband. The quad seal provides a low friction, long lasting seal, proven dependable for years of trouble free service. The wearband provides additional alignment and support for the piston seal.

Scotch Yoke

The slot in the scotch yoke mechanism is precision machined. The yoke pin is induction hardened and chrome plated. It is supported at the top and bottom by a guide slot in the housing and the yoke pin rollers are hardened steel.

Indicator/Output shaft

Top accessory shaft has NAMUR slot, and optional position indicator.

Spring Module

The spring module is an easily removable, welded cartridge.

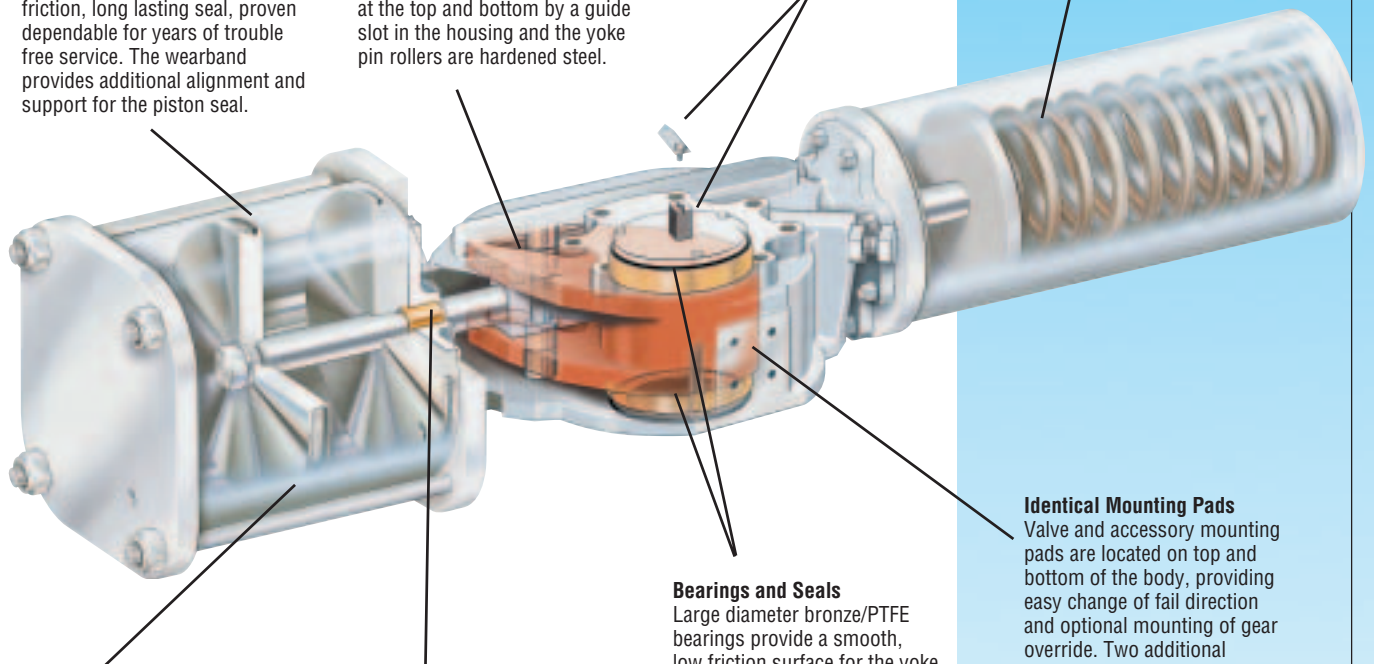

Cylinder

The cylinders are honed to a micro finish with a hard chrome plating.

Piston Rods and Rod Bearings

Piston rods are guided and supported by self lubricating bronze bearings. The rods are ground, high strength steel with a hard chrome plating, polished to a mirror finish.

Bearings and Seals

Large diameter bronze/PTFE bearings provide a smooth, low friction surface for the yoke journal. The seals protect the bearings from external dirt and corrosion, while the bearing's rigid design prolongs seal life.

Identical Mounting Pads

Valve and accessory mounting pads are located on top and bottom of the body, providing easy change of fail direction and optional mounting of gear override. Two additional mounting pads are available on the side of the body for mounting accessories.

Heavy Duty Torque Charts

Double Acting

Model	Torque	40	60	80	100
R205	Break	3302	4953	6604	8255
	Run	1865	2798	3731	4663
R206	Break	4899	7348	9797	12246
	Run	2767	4151	5535	6918
R207	Break	6785	10178	13571	16963
	Run	3833	5750	7667	9583
R208	Break	8962	13444	17925	NA
	Run	5063	7595	10126	
R310	Break	13607	20411	27214	34018
	Run	7687	11531	15374	19218
R312	Break	19993	29990	39990	49985
	Run	11295	16940	22590	28240
R314	Break	27541	41310	55080	NA
	Run	15560	23340	31120	
R316	Break	36250	54375	NA	NA
	Run	20480	30720		
R414	Break	40005	60010	80010	100010
	Run	22600	33900	45200	56500
R416	Break	53070	79600	106135	132670
	Run	29980	44970	59960	74950
R418	Break	67870	101810	135745	169680
	Run	38343	57515	76685	95860
R420	Break	84420	126630	168835	NA
	Run	47690	71540	95380	
R422	Break	102706	154059	NA	NA
	Run	58022	87033		

Spring Return

Model	Torque	40	60	80	100
R205SR	Pneumatic Break	2297	3447	4594	5668
	Pneumatic End	1244	1922	2474	2954
	Spring Break	2291	3379	4595	5882
	Spring End	1237	1854	2475	3168
R206SR	Pneumatic Break	3235	4961	6543	8268
	Pneumatic End	1710	2842	3829	4197
	Spring Break	3379	4793	6349	8527
	Spring End	1854	2673	3636	4455
R207SR	Pneumatic Break	4452	6755	9003	10987
	Pneumatic End	2333	4041	4932	5560
	Spring Break	4595	6349	8923	11759
	Spring End	2475	3636	4851	6331
R208SR	Pneumatic Break	5880	8721	11764	14704
	Pneumatic End	3166	4649	6337	7927
	Spring Break	5882	8923	11759	14692
	Spring End	3168	4851	6331	7915
R310SR	Pneumatic Break	9187	13785	18379	22824
	Pneumatic End	4958	7683	9226	10350
	Spring Break	9189	13522	19049	24993
	Spring End	4950	7420	9895	12519
R312SR	Pneumatic Break	12937	19849	26167	33083
	Pneumatic End	6835	10696	13693	16451
	Spring Break	13522	19841	27022	34443
	Spring End	7420	10687	14548	17811
R314SR	Pneumatic Break	17813	27015	36023	43937
	Pneumatic End	8660	14541	19391	22229
	Spring Break	19049	27022	36027	47043
	Spring End	9895	14548	19395	25335
R316SR	Pneumatic Break	23672	34892	47047	NA
	Pneumatic End	11198	18260	25339	
	Spring Break	24993	36027	47043	
	Spring End	12519	19395	25335	
R414SR	Pneumatic Break	27017	40522	54034	65906
	Pneumatic End	14563	21811	29613	34984
	Spring Break	27000	40534	53514	68924
	Spring End	14546	21823	29092	38002
R416SR	Pneumatic Break	35285	52338	70571	87623
	Pneumatic End	16574	27916	39649	46374
	Spring Break	37712	53514	68924	89343
	Spring End	19001	29092	38002	48094
R418SR	Pneumatic Break	44656	65057	89320	111651
	Pneumatic End	20235	34036	48070	60743
	Spring Break	48472	68924	89343	111024
	Spring End	24050	38002	488094	60115
R420SR	Pneumatic Break	55731	82705	109531	137834
	Pneumatic End	31309	41456	58622	74229
	Spring Break	53514	85779	111024	137828
	Spring End	29092	44530	60115	74223
R422SR	Pneumatic Break	64633	101472	131049	NA
	Pneumatic End	33712	50564	67443	
	Spring Break	68924	103390	137828	
	Spring End	38002	52481	74223	

Heavy Duty Torque Charts

R5 Pneumatic Double Acting Torques						R5 Pneumatic Spring Return Torques					
Model	Torque	40	60	80	100	Model	Torque	40	60	80	100
R514DA	Break	73978	110967	147956	184945	R516SR	Pneumatic Break	NA	NA	NA	156005
	Run	44083	66124	88166	110207		Pneumatic End				85871
R516DA	Break	97370	146056	194741	243426		Spring Break				148061
	Run	58022	87033	116044	145055		Spring End				88837
R518DA	Break	123882	185822	247763	309704	R518SR	Pneumatic Break	82154	119224	159124	200290
	Run	73820	110730	147640	184550		Pneumatic End	39519	66535	88990	113660
R51414DA	Break	150393	225589	300786	375982		Spring Break	78533	111234	148061	182885
	Run	89618	134426	179235	224044		Spring End	41956	66740	88837	109731
R520DA	Break	153512	230268	307024	383780	R520SR	Pneumatic Break	98195	149578	196391	250315
	Run	91476	137214	182952	228691		Pneumatic End	54881	79902	109761	145647
R51614DA	Break	173785	260678	347570	434463		Spring Break	91442	139352	182885	220965
	Run	103557	155335	207114	258892		Spring End	54865	80127	109731	132579
R522DA	Break	186261	279392	372522	465653	R522SR	Pneumatic Break	118445	189534	237839	304023
	Run	110991	166487	221982	277478		Pneumatic End	65755	119400	133171	178232
R51616DA	Break	197177	295766	394355	492944		Spring Break	111234	148061	220965	265558
	Run	117496	176244	234992	293740		Spring End	66740	88837	132579	159335
R524DA	Break	222129	333194	444258	NA	R524SR	Pneumatic Break	140221	221343	281411	364896
	Run	132365	198547	264729	NA		Pneumatic End	70545	134713	155620	217507
R51816DA	Break	223689	335533	447377	NA		Spring Break	139352	182885	265558	311154
	Run	133294	199941	266588	NA		Spring End	80127	109731	159335	186693
R51818DA	Break	250200	375300	500400	NA	R52214SR	Pneumatic Break	171600	258112	333706	438098
	Run	149092	223638	298183	NA		Pneumatic End	101466	153445	186318	269586
R52020DA	Break	309460	464191	NA	NA		Spring Break	148061	220965	311154	355748
	Run	184404	276607	NA	NA		Spring End	88837	132579	186693	213449
R52416SR	Pneumatic Break	208867	318838	424063	NA	R52416SR	Pneumatic Break	208867	318838	424063	NA
	Pneumatic End	122237	193047	255551			Pneumatic End	122237	193047	255551	
	Spring Break	182885	265558	355748			Spring Break	182885	265558	355748	
	Spring End	109731	159335	213449			Spring End	109731	159335	213449	

How To Order *(Select Bold Type Code from each column that applies)*

Model	Cylinder Size	Type	Spring Size	Override	Temperature	Material/Coating
R2	05-5" dia. 06-6" dia. 07-7" dia. 08-8" dia.	DA -Double Acting	Blank - DA	Blank -None	Blank - Standard 20°-180° F (nitrile seals). V - High Temp. 0° to 300° F (viton seals). L - Low Temp. -55° to 180°F (nitrile seals, heat treated body)	Blank Standard; Epoxy undercoat with Polyurethane top coat F -AWWA, specifications intent E - Epoxy paint (white) M - Marine Trim
		SR -Spring Return FCW	40 -40 psi air supply	G -Declutch Gear		
R3	10-10" dia. 12-12" dia. 14-14" dia. 16-16" dia.	SO -Spring Return FCCW	60 -60 psi air supply	H - Hydraulic		
			80 -80 psi air supply	J - Jackscrew		
R4	14-14" dia. 16-16" dia. 18-18" dia. 20-20" dia. 22-22" dia.		100 -100 psi air supply	S - Hydraulic Snubber		
				B - Delutch Gear w/ Hydraulic Snubber		
R5	14-14" dia. 16-16" dia. 18-18" dia. 20-20" dia. 22-22" dia. 24-24" dia.					

Example: A model R310 spring return (FCW) with 60 psi air supply and viton seals would be: **R310SR60V**

For hydraulic or electro-hydraulic actuators, consult factory.

Note: In some instances for the R5 actuator, a second cylinder size is required to complete the model number. Consult torque charts.

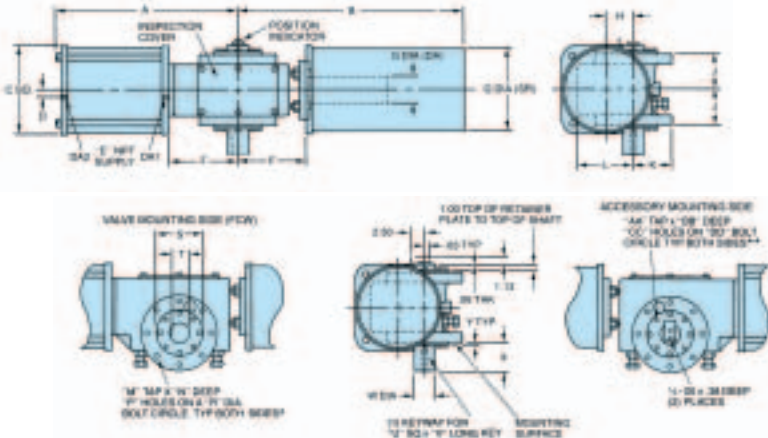

Notes:

1. All dimensions are in inches.
2. Pressure at port side DA1 will result in clockwise rotation, pressure at port DA2 will result in counterclockwise rotation.
3. Orientation of accessory output may be indexed 90°.

- * R2 Has only 4 holes at 45°
- **R4 8 each 3/8 - 16x 3/4" deep holes on center line of "DD" diameter bolt circle are available for accessory mounting. The 3/8-16 x 1" long hex head cap screws must be replaced by a longer bolt equal to the thickness of the mounting bracket. The retainer plate is 1/2" thick.
- **R2-R3 A clearance hole for a 5/16" hex cap screw and lock-washer may be required to clear the retainer plate bolts on the center line of "DD" diameter bolt circle.

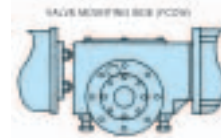

Model	A	B					C	D	E	F	G					H	J	K	L
		DA	SR40	SR60	SR80	SR100					DA	SR40	SR60	SR80	SR100				
R205	19.82	17.01	29.00	30.00	32.00	33.00	5.75	1.19	1/4	7.19	2.00	9.13	9.13	9.13	9.13	3.00	3.25	2.78	5.75
R206	19.82	17.01	30.00	30.00	32.00	38.00	6.75	1.19	1/4	7.19	2.00	9.13	9.13	9.13	9.13	3.00	3.25	2.78	5.75
R207	19.82	17.01	30.00	32.00	38.00	40.00	7.75	1.19	1/4	7.19	2.00	9.13	9.13	9.13	9.13	3.00	3.25	2.78	5.75
R208	19.82	17.01	33.00	38.00	40.00	41.00	8.75	1.19	1/4	7.19	2.00	9.13	9.13	9.13	9.13	3.00	3.25	2.78	5.75
R310	23.00	18.13	34.00	36.00	39.00	42.00	10.75	0.00	3/8	8.19	3.50	13.25	13.25	13.25	13.25	3.00	4.13	4.44	6.81
R312	23.00	18.13	36.00	38.00	41.00	43.00	12.75	0.00	3/8	8.19	3.50	13.25	13.25	13.25	13.25	3.00	4.13	4.44	6.81
R314	23.50	18.13	39.00	41.00	44.00	45.00	14.75	0.00	1/2	8.19	3.50	13.25	13.25	13.25	14.63	3.00	4.13	4.44	6.81
R316	23.75	18.13	42.00	44.00	45.00	N/A	16.88	0.00	1/2	8.19	3.50	13.25	13.25	14.63	N/A	3.00	4.13	4.44	6.81
R414	30.87	25.37	50.00	56.00	59.00	55.00	14.75	0.00	1/2	11.56	4.50	14.63	14.63	14.63	16.63	4.50	5.82	6.50	9.75
R416	31.12	25.37	57.00	59.00	55.00	56.00	16.88	0.00	1/2	11.56	4.50	14.63	14.63	16.63	16.63	4.50	5.82	6.50	9.75
R418	31.69	25.37	59.00	56.00	57.00	59.00	20.88	0.00	3/4	11.56	4.50	16.63	16.63	16.63	16.63	4.50	5.82	6.50	9.75
R420	31.94	25.37	59.00	56.00	57.00	59.00	20.88	0.00	3/4	11.56	4.50	16.63	16.63	16.63	16.63	4.50	5.82	6.50	9.75
R422	32.12	25.37	55.00	58.00	59.00	N/A	23.75	0.00	3/4	11.56	4.50	16.63	16.63	16.63	N/A	4.50	5.82	6.50	9.75

Model	M	N	P	R	S	T	U	V	W	X	Y	AA	BB	CC	DD
R2	5/8-11	1.00	4	5.750	4.25	1.718	.500	1.59	2.000	2.25	.31	1/4-20	.31	4	3.562
R3	5/8-11	1.13	8	7.500	5.00	2.148	.625	3.50	2.500	4.25	.31	1/4-20	.31	4	4.375
R4	7/8-9	1.13	8	11.000	8.00	3.261	.875	4.06	3.750	5.00	.50	3/8-16	**	8	7.187

VOLUMES & WEIGHTS Double Acting & Spring Returns

Model Number	Volumes In ³	Estimated Weights (lbs.)				
		DA	SR40	SR60	SR80	SR100
R205	137	124	186	189	193	198
R206	198	133	198	202	205	222
R207	269	144	213	218	233	238
R208	352	155	227	244	248	256
R310	550	290	423	435	448	465
R312	792	339	484	496	514	531
R314	1078	401	560	576	593	665
R316	1407	486	661	678	749	NA
R414	1539	665	904	941	968	1127
R416	2010	765	1039	1067	1226	1169
R418	2544	901	1203	1362	1305	1423
R420	3141	1038	1507	1443	1559	1578
R422	3801	1347	1816	1869	1887	NA

R5SR

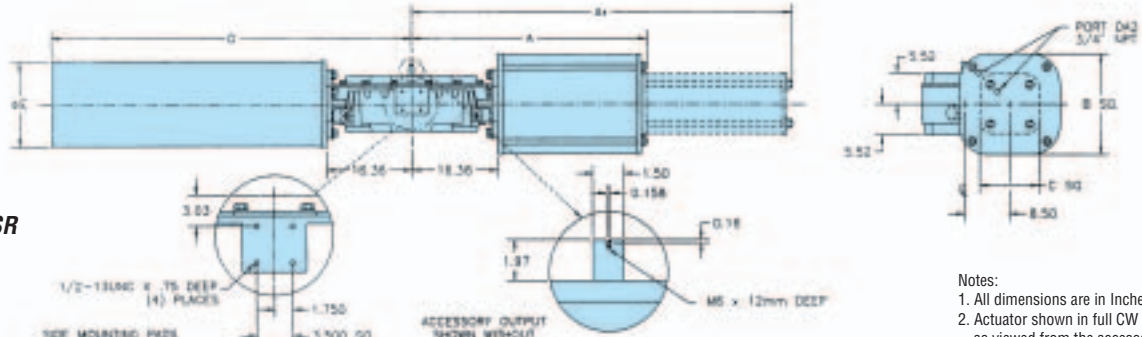

R5DA

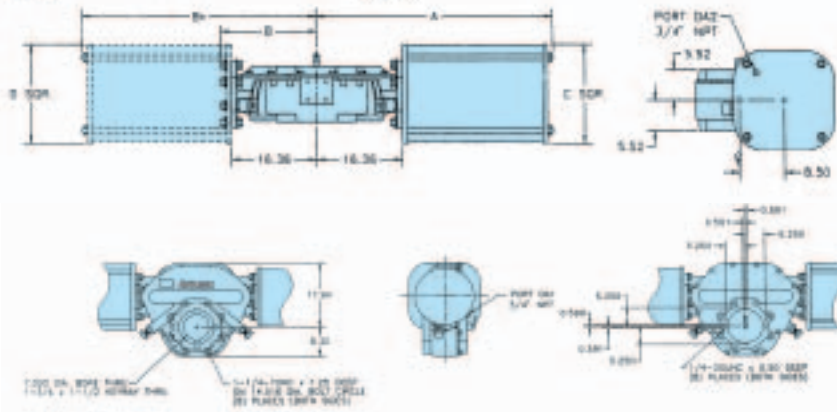

Valve Mounting

Accessory

Notes:

1. All dimensions are in Inches.
2. Actuator shown in full CW position, as viewed from the accessory side.
3. Pressure at port side DA1 will result in clockwise rotation, pressure at port DA2 will result in counterclockwise rotation.
4. Orientation of accessory output may be indexed 90°.

Actuator	A	B	B*	C	D
R514DA	44.17	17.46	N/A	14.75	N/A
R51414DA	44.17	N/A	44.17	14.75	14.75
R516DA	44.67	17.46	N/A	16.88	N/A
R51614DA	44.67	N/A	44.17	16.88	14.75
R51616DA	44.67	N/A	44.67	16.88	16.88
R518DA	45.00	17.46	N/A	18.88	N/A
R51816DA	45.00	N/A	44.67	18.88	16.88
R51818DA	45.00	N/A	40.00	18.88	18.88
R520DA	45.13	17.46	N/A	20.88	N/A
R52020DA	45.13	N/A	45.13	20.88	20.88
R522DA	45.50	17.46	N/A	23.13	N/A
R524DA	46.00	17.46	N/A	25.50	N/A

Actuator Model	Volume (in ³)	Weights (lb.)				
		DA	SR40	SR60	SR80	SR100
R514	3233	932	N/A	N/A	N/A	N/A
R51414	6466	1199	N/A	N/A	N/A	N/A
R516	4222	1066	N/A	N/A	N/A	2040
R51614	7455	1333	N/A	N/A	N/A	N/A
R51616	8444	1467	N/A	N/A	N/A	N/A
R518	5344	1180	1938	1992	2153	2260
R51816	9566	1581	N/A	N/A	N/A	N/A
R51818	10688	1695	N/A	N/A	N/A	N/A
R520	6597	1297	2035	2253	2378	2559
R52020	13194	1929	N/A	N/A	N/A	N/A
R522	7983	1463	2276	2437	2725	2888
R52214	11216	N/A	2704	2992	3274	3437
R524	9500	1730	2686	2811	3155	3274
R52416	13722	N/A	3212	3556	3838	N/A

Actuator	A	A*	B	C	D								E
					40	60	80	100	125	150	175	200	
R516SR	44.75	N/A	16.88	N/A	N/A	N/A	N/A	79.00	84.00	96.49	96.49	96.49	16.00
R518SR	45.00	N/A	18.88	N/A	76.00	71.50	79.00	84.00	96.49	96.49	96.49	96.49	16.00
R520SR	45.13	N/A	20.88	N/A	70.00	81.50	84.00	96.49	96.49	96.49	96.49	N/A	16.00
R522SR	45.50	N/A	23.13	N/A	71.50	79.00	96.49	96.49	96.49	96.49	N/A	N/A	16.00
R524SR	46.00	N/A	25.50	N/A	81.50	84.00	96.49	96.49	96.49	N/A	N/A	N/A	16.00
R52214SR	45.50	71.88	23.13	14.75	79.00	96.49	96.49	96.9	N/A	N/A	N/A	N/A	16.00
R52416SR	46.00	72.88	25.50	16.88	84.00	96.49	96.49	N/A	N/A	N/A	N/A	N/A	16.00

Flowserve Corporation has established industry leadership in the design and manufacture of its products. When properly selected this Flowserve product is designed to perform its intended function safely during its useful life. However, the purchaser or user of Flowserve products should be aware that Flowserve products might be used in numerous applications under a wide variety of industrial service conditions. Although Flowserve can (and often does) provide general guidelines, it can not provide specific data and warnings for all possible applications. The purchaser/user must therefore assume the ultimate responsibility for the proper sizing and selection, installation, operation, and maintenance of Flowserve products. The purchaser/user should read and understand the Installation Operation Maintenance (IOM) instructions included with the product, and train its employees and contractors in the safe use of Flowserve products in connection with the specific application.

While the information and specifications contained in this literature are believed to be accurate they are supplied for informative purposes only and should not be considered certified or as a guarantee of satisfactory results by reliance thereon. Nothing contained herein is to be construed as a warranty or guarantee, express or implied, regarding any matter with respect to this product. Because Flowserve is continually improving and upgrading its product design, the specifications, dimensions and information contained herein are subject to change without notice. Should any question arise concerning these provisions, the purchaser/user should contact Flowserve Corporation at any one of its worldwide operations or offices.

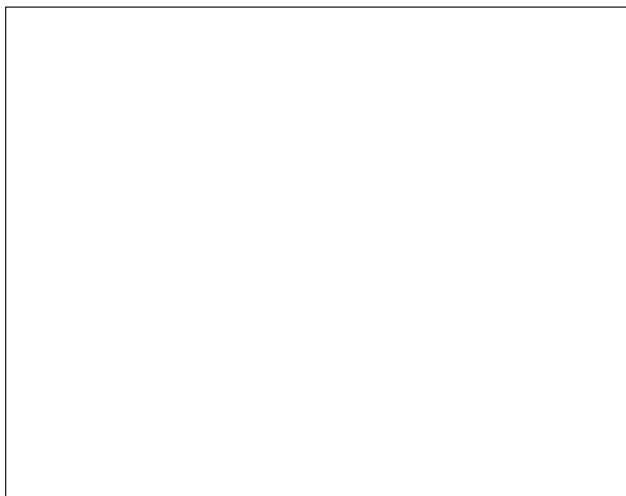

For more information about Flowserve Corporation, contact www.flowserve.com or call USA 972 443 6500.

**FLOWSERVE CORPORATION
FLOW CONTROL DIVISION**

765 South 100 East
Provo, Utah 84606 USA
Telephone 801 373 3028
Facsimile 801 489 2228

1978 Foreman Drive
Cookeville, Tennessee 38501 USA
Telephone 931 432 4021
Facsimile 931 432 5518