



tyco

Cash Valve

TA SERIES

**TEMPERATURE
REGULATORS**

ISSUED - JANUARY 2001
CAVMC-0519-US-0208
ISO 9001 Certified

TEMPERATURE REGULATORS

APPLICATIONS

FIG. 1 — CONTROLLING STORAGE HEATER

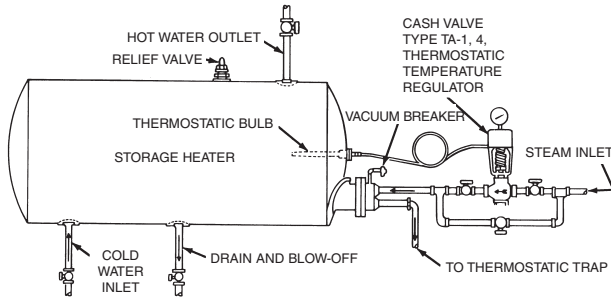

FIG. 2 — CONTROLLING OIL PREHEATER

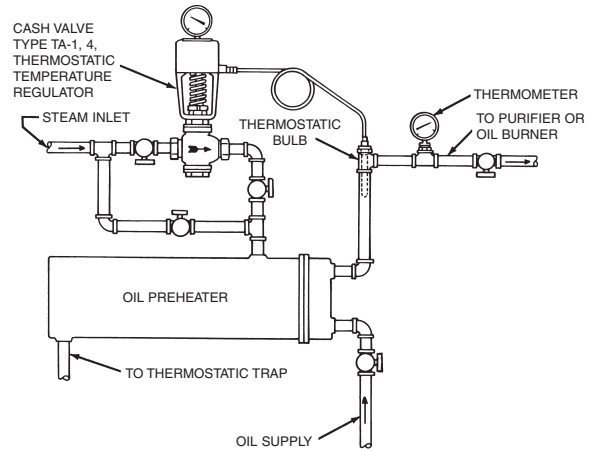

FIG. 3 — CONTROLLING INSTANTANEOUS WATER HEATER

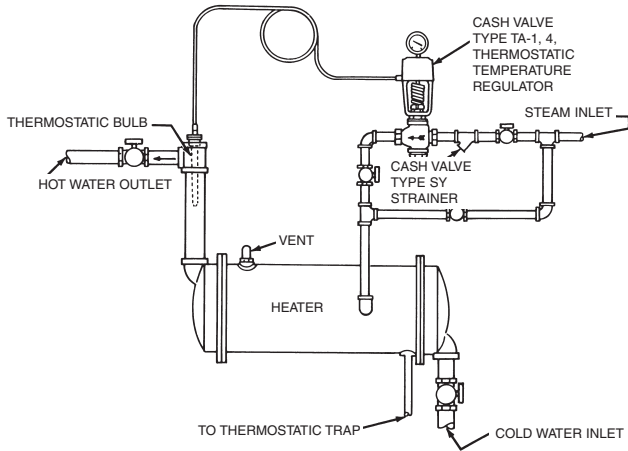

FIG. 4 — CONTROLLING OIL COOLER

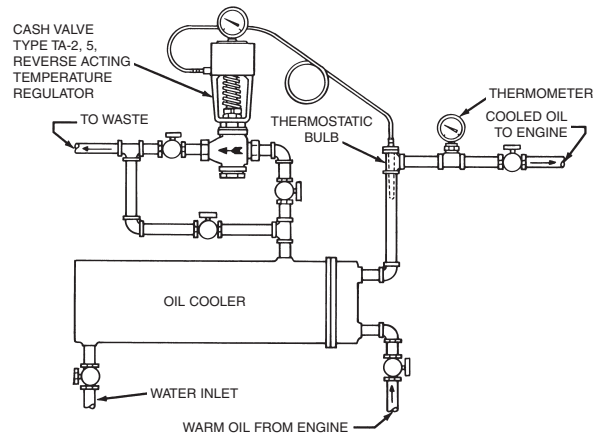

FIG. 5 — TYPE TA 3-WAY USED AS A MIXING VALVE
(Flow travels in direction of arrow cast on body.)

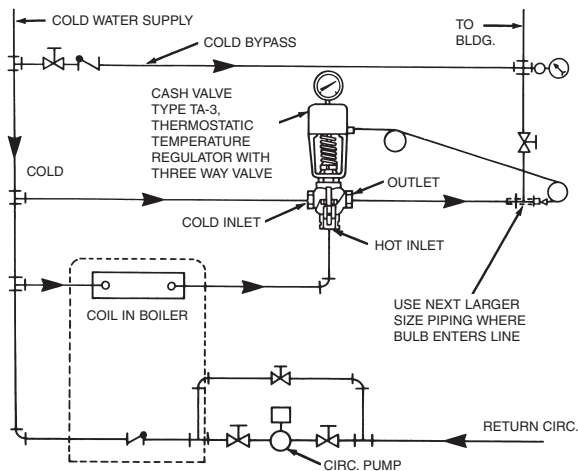
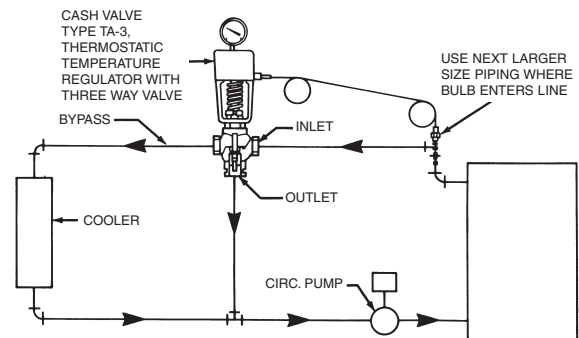
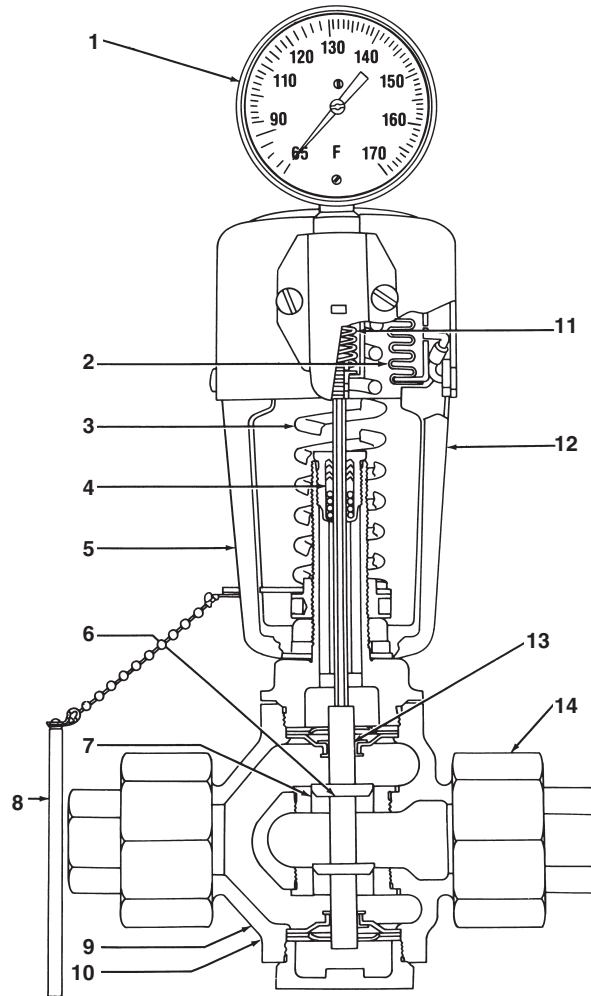

FIG. 6 — TYPE TA 3-WAY USED AS A DIVERTING VALVE
(Flow travels in opposite direction of arrow cast on body.)



FEATURES



1. **Positionable Temperature Indicator:** may be turned in direction of easiest reading. Highly accurate, stainless steel case, with bayonet lock ring.
2. **Thermal System:** heavy duty bronze bellows, with bronze spiral armored copper capillary, copper bulb, with epoxy coated bellows housing. (See page 5 for other line and bulb materials.)
3. **Extra long Adjusting Spring:** permits adjustment over wide range of temperatures.
4. **Packing Assembly:** spring loaded self adjusting chevron type teflon packing, eliminates completely the human factor of improper adjustment.
5. **Full scale Adjustment:** makes repeating settings easy and accurate.
6. **Stainless Steel Disc:** self-aligning to assure accurate seating, long wear, and tight closure.
7. **Stainless Steel Seat Rings:** threaded and bonded to eliminate any possibility of leakage through seat ring threads.
8. **Adjusting Key:** conveniently located — always there when settings have to be changed.
9. **Heavy section valve Body:** tough, solid and durable, will withstand severe piping strains, for pressures to 250 psig at 406°F (208°C).

10. **Full ported and full flow valve body:** provides maximum capacity for each valve size. Valve body is bronze.
 11. **Over temperature protection:** prevents damage to regulator through inadvertent over-heating.
 12. **Epoxy-coated compact one-piece channel Frame:** permits installation in tight location.
 13. **Double guided stainless steel monolithic Disc Assembly:** maintains proper alignment of all moving parts.
 14. **Galvanized iron Union Ends:** for sturdiness and ease of installation.
- Patented temperature compensator: on double seated valves compensating connector is used to assure uniform positioning of discs for tight shut-off when changes in temperature affect the valve body.

Maximum size is 2". For sizes up to 4", consult the factory.

Only stainless steel trim is available. We feel it's much better to furnish a longer-lasting trim because it cuts down on maintenance costs.

All Cash Valve temperature regulators are furnished as standard with a brass or stainless steel union bushing. In "over the rim" installations, please specify "no union bushing."

Wells are available upon request. They come in brass or stainless steel. See page 8 for details.

The leakage rate on both the single and double ported valves is considerably lower than most other kinds of temperature regulators. Our single port leakage is less than .5%. Our double port leakage is less than 1%.

TEMPERATURE REGULATORS

SPECIFICATIONS DIRECT ACTING/REVERSE ACTING

Specifications given on this page are for direct acting (for heating) and reverse acting (for cooling) temperature regulators. Direct Acting valves are designed with a normally open valve seat which closes on increasing temperature. Reverse Acting valves are designed with normally closed valve seats that open on increasing temperature. All Cash Valve Direct Acting and Reverse Acting Temperature Regulators are available with either single seat or double seat. All temperature regulators are indicating. See page 5 for thermal system information.

Size	SINGLE SEAT			DOUBLE SEAT		
	Type Indicating	Flow Coefficient C_v	Max. Upstream Press.-psig	Type Indicating	Flow Coefficient C_v	Max. Upstream Press.-psig
*1/2C	TA-1	0.40	250	NOT AVAILABLE IN DOUBLE SEAT		
*1/2D		1.00				
*1/2E		1.80				
*1/2A		3.29				
*1/2B		4.29				
1/2	TA-2	5.22	140	TA-4 TA-5	7.93	250
3/4	6.85	90	10.4			
1	9.15	65	12.9			
1 1/4	14.3	40	20.6			
1 1/2	15.1	30	24.8			
2	17.2	20	33.0			

TYPE	SPECIFICATIONS
TA-1	Direct Acting, Single Seat, Indicating
TA-2	Reverse Acting, Single Seat, Indicating
TA-3	3-Way, Single Seat, Indicating
TA-4	Direct Acting, Double Seat, Indicating
TA-5	Reverse Acting, Double Seat, Indicating

*Indicates non-standard valve, special order only.

NOTE: Maximum upstream pressure of all single seat valves decreases as the valve size increases (see table above).

Particular attention should be given to this fact when sizing for your pressure conditions; the more nearly balanced double seat valve is recommended for higher upstream pressures.

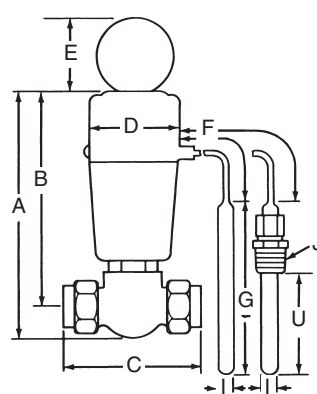

SINGLE-SEATED DIRECT ACTING BRONZE VALVE

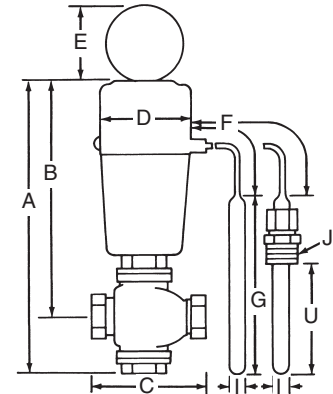

DOUBLE-SEATED REVERSE ACTING BRONZE VALVE

DIMENSIONS								
Size	Type	A	B	C	D	E	F	Ship. Wt Lbs.
1/2 (A,B,C,D,E) 1/2, 3/4	TA-1 TA-2	9 ³ / ₄	8 ¹ / ₂	5 ¹ / ₂	3 ¹ / ₂	2 ¹³ / ₁₆	8 ft.	13
1/2 3/4	TA-4 TA-5	12 ⁷ / ₁₆	9 ³ / ₄	7 ³ / ₁₆	3 ¹ / ₂	2 ¹³ / ₁₆	8 ft.	13
1	TA-1	12 ⁷ / ₁₆	9 ³ / ₄	7 ³ / ₁₆	3 ¹ / ₂	2 ¹³ / ₁₆	8 ft.	13
1 1/4 1 1/2 2	TA-2 TA-4 TA-5	12 ⁷ / ₈	9 ³¹ / ₃₂	8 ¹⁵ / ₁₆	3 ¹ / ₂	2 ¹³ / ₁₆	8 ft.	20 20 21

BULB SIZES	G	U	I			J
			Plain	Union	Well	
Small	13 ³ / ₈	10 ¹ / ₂	5/8	5/8	3/4	3/4 NPT
Large	15 ⁵ / ₈	12 ¹ / ₂	1	1	1 1/8	1 NPT
Extra Large	19	16	1	1	1 1/8	1 NPT

SPECIFICATIONS 3-WAY

Cash Valve 3-way temperature regulators are designed so that hot and cold water are throttled to provide a controlled mix temperature. For typical installations, see "Applications," page 2. All Cash Valve 3-way temperature regulators are single seat, indicating valves. See below for thermal system information.

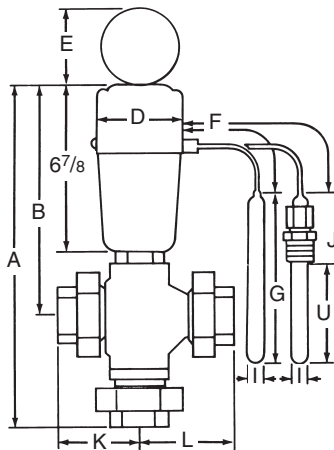

THREE-WAY VALVE

3-WAY			
Size	Type	Flow Coefficient C_v	Max. Diff. Between inlet Pressures* - psi
	Indicating		
1/2	TA-3	5.22	140
3/4		6.85	90
1		9.15	65
1 1/4		14.3	40
1 1/2		15.1	30
2		17.2	20

NOTE: Maximum upstream pressure on all 3-way valves is 250 psi. Maximum differential between inlet pressures decreases as valve size increases. See table above.

DIMENSIONS									
Size	Type	A	B	D	E	F	K	L	Ship. Wt Lbs.
1/2	TA-3	13 ^{7/8}	9 ^{3/4}	3 ^{1/2}	2 ^{13/16}	8 ft.	3 ^{5/16}	3 ^{5/8}	13
3/4		13 ^{7/8}	9 ^{3/4}	3 ^{1/2}		8 ft.	3 ^{5/16}	3 ^{5/8}	13
1		13 ^{7/8}	9 ^{3/4}	3 ^{1/2}		8 ft.	3 ^{5/16}	3 ^{5/8}	13
1 1/4		14 ^{21/32}	9 ^{31/32}	3 ^{1/2}		8 ft.	4 ^{1/8}	4 ^{11/16}	20
1 1/2		14 ^{21/32}	9 ^{31/32}	3 ^{1/2}		8 ft.	4 ^{1/8}	4 ^{11/16}	20
2		14 ^{7/8}	9 ^{31/32}	3 ^{1/2}		8 ft.	4 ^{3/16}	4 ^{7/8}	21

BULB SIZES	G	U	I			J
			Plain	Union	Well	
Small	13 ^{3/8}	10 ^{1/2}	5/8	5/8	3/4	3/4 NPT
Large	15 ^{5/8}	12 ^{1/2}	1	1	1 ^{1/8}	1 NPT
Extra Large	19	16	1	1	1 ^{1/8}	1 NPT

SPECIFICATIONS THERMAL SYSTEMS

The thermal system on all Cash Valve Temperature Regulators is accurate to $\pm 5^\circ\text{F}$ ($\pm 3^\circ\text{C}$) or better. Standard bulb is bronze, standard capillary line is bronze with armor cover. Standard line length is 8'. Optional line lengths of 15', 20', 30' and 40' are available on special order.

Extra large bulb is available on special order only.

Bulbs and capillary lines are available coated with PVC or Teflon® on special order only. Maximum operating temperature is 180°F (82°C) for PVC and 450°F (232°C) for Teflon®. Maximum Teflon® line length is 15'.

RANGES, BULB SIZES, AND MAXIMUM LINE LENGTHS			
RANGES		BULB SIZE	†MAX. LINE LENGTH
°FAHR	°CENT.		
-15/75	-25/20	†Large	15 ft.
		Extra Large	40 ft.
*45/145	*10/60	†Large	10 ft.
		Extra Large	40 ft.
*65/170	*20/75	†Large	20 ft.
		Extra Large	40 ft.
*90/195	*35/90	†Large	20 ft.
		Extra Large	40 ft.
*120/230	*50/100	Small	40 ft.
*240/340	*115/170	Small	40 ft.
280/415	140/210	Small	40 ft.

* Indicates standard temperature ranges. Other ranges shown are available on special order only.

† Indicates standard bulb size. Other bulb sizes shown are available on special order only.

TEMPERATURE REGULATORS

SIZING/APPLICATIONS MAXIMUM WATER FLOW – FOR COOLING

EXAMPLE: Find the correct regulator valve size that will feed a compressor intercooler that requires 100 gallons of water per minute under maximum operating conditions. The supply (inlet) pressure (P_1) is 60 psi and the downstream pressure (P_2) under maximum flow conditions is 20 psi. The 20 psi pressure is required to force the full flow of water through the compressor's cooling system. Inlet pressure must not exceed

maximum upstream pressure, per pages 4 and 5.

ANSWER: The pressure drop permitted across the regulator is P_1 minus P_2 or 40 psi. Locate 40 psi in the differential pressure column and read across to the required gallons per minute. Read to the highest value in this case 130 GPM. The chart shows that a 1 1/4-inch double seated valve is required.

psig	SINGLE SEAT/3-WAY VALVES						DOUBLE SEATED VALVES					
	1/2	3/4	1	1 1/4	1 1/2	2	1/2	3/4	1	1 1/4	1 1/2	2
DIFF. PRESS.	WATER FLOW – U.S. GAL. PER MIN.											
5	12	15	20	32	34	38	18	23	29	46	55	74
10	17	22	29	45	48	54	25	33	41	65	78	104
15	20	27	35	55	59	67	31	40	50	80	96	128
20	23	31	41	64	68	77	35	47	58	92	111	148
25	26	34	46	72	76	86	40	52	65	103	124	165
30	29	38	50	78	83		43	57	71	113	136	181
40	33	43	58	90			50	66	82	130	157	209
50	37	48	65				56	74	91	146	175	233
60	40	53	71				61	81	100	160	192	256
70	44	57					66	87	108	172	207	276
80	47	61					71	93	115	184	222	295
90	50	65					75	99	122	195	235	313
100	52						79	104	129	206	248	330
110	55						83	109	135	216	260	346
120	57						87	114	141	226	272	361
130	60						90	119	147	235	283	376
140	62						94	123	153	244	293	390
150							97	127	158	252	304	404
160							100	132	163	261	314	417
170							103	136	168	269	323	430
180							106	140	173	276	333	443
190							109	143	178	284	342	455
200							112	147	182	291	351	467
210							115	151	187	299	359	478
220							118	154	191	306	368	489
230							120	158	196	312	376	500
240							123	161	200	319	384	511
250							125	164	204	326	392	522

NOTE: Blank spaces indicate that pressure limitations have been exceeded.

STEAM FLOW REQUIREMENT – FOR HEATING

Use this chart to determine the pounds of steam per hour required to raise the temperature in tank of known capacity to the temperature required. Determine the rise in temperature (control temp. - room temp.) on the left hand column, read the corresponding pounds of steam per hour under the

corresponding gallons of water to be heated. Use the lbs. steam/hr. figure in the chart on page 7 to determine valve size.

Formula for converting the length, width, and depth of solutions, all measured in feet, to gallons of solution:

$$\text{gallons} = 7.48 \times \text{length} \times \text{width} \times \text{depth}$$

TEMP. RISE °F.	GALLONS OF WATER HEATED PER HOUR											LBS. STEAM/HR.
	25	50	75	100	150	200	300	400	500	750	1000	
10	2	4	6	8	12	17	25	33	42	63	83	
20	4	8	12	17	25	33	50	67	83	120	167	
30	6	12	19	25	37	50	70	100	120	190	250	
40	9	17	25	33	50	66	100	130	170	250	330	
50	11	21	31	42	63	84	125	170	210	310	420	
60	13	25	37	50	75	100	150	200	250	370	500	
80	17	33	50	67	100	130	200	270	330	500	670	
100	21	42	63	83	120	170	250	330	420	630	830	
120	25	50	75	100	150	200	300	400	500	750	1000	
140	29	58	88	117	175	230	350	470	580	880	1170	
160	33	66	100	133	200	270	400	530	660	1000	1330	

TEMPERATURE REGULATORS

SPECIFICATIONS - ACCESSORIES

WELLS					
Cat No.	Material	Bulb Dia.	NPT	U	Well Dia.
A	Brass	5/8"	3/4"	10 1/2"	3/4"
E	304 St. St.	5/8"	3/4"	10 1/2"	3/4"
G	316 St. St.	5/8"	3/4"	10 1/2"	3/4"
J	Brass	1"	1"	12 1/2"	1 1/8"
*K	Brass	1"	1"	16"	1 1/8"
N	304 St. St.	1"	1"	12 1/2"	1 1/8"
*P	304 St. St.	1"	1"	16"	1 1/8"
Q	316 St. St.	1"	1"	12 1/2"	1 1/8"
*R	316 St. St.	1"	1"	16"	1 1/8"

*Indicates optional well available on special order only.

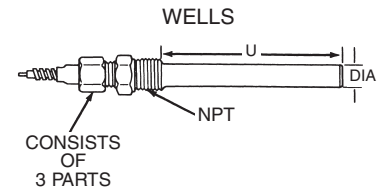

UNION BUSHINGS			
Cat No.	Material	Bulb Dia.	NPT
AA	Brass	5/8"	3/4"
CC	St. St.	5/8"	3/4"
EE	Brass	1"	1"
FF	St. St.	1"	1"

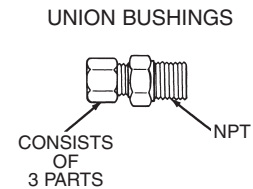

HOW TO ORDER

TYPE	SPECIFICATIONS
TA-1	Direct Acting, Single Seat, Indicating
TA-2	Reverse Acting, Single Seat, Indicating
TA-3	3-Way, Single Seat, Indicating
TA-4	Direct Acting, Double Seat, Indicating
TA-5	Reverse Acting, Double Seat, Indicating

1. Select proper temperature regulator listed in chart at left.
2. Size regulator for specific conditions: See page 6 for water flows. See page 7 for steam flows.
3. Specify range desired. See Thermal Systems, page 5 for available ranges.
4. Specify maximum line length desired. See Thermal Systems, page 5 for limitations.
5. Standard line and bulb material is bronze. For special order options see Thermal Systems, page 5.
6. Specify bulb size. See Thermal Systems, page 5.
7. If a well is desired, select from chart above.

NOTE: ALL CASH VALVE TYPE TA TEMPERATURE REGULATORS ARE INDICATING VALVES.

Cash Valve
 953 Old U.S. Highway 70
 Black Mountain, NC 28771
 Phone: 800-879-2042 • 828-669-3710
 Fax: 800-879-2057 • 828-669-0586
 CAVMC-0519-US-0208

Tyco Valves & Controls
 www.cashvalve.com