



***tyco***

---

***Cash Valve***

**TYPE C-776**

**CRYOGENIC  
SAFETY RELIEF  
VALVE**

ISSUED - APRIL 2000  
CAVMC-0515-US-0208  
ISO 9001 Certified

# TYPE C-776

## DESCRIPTION

The Type C776 is a full lift safety relief valve suitable for cryogenic service. The Type C776 combines top guided construction with an unobstructed seat bore to provide maximum discharge capacity. Superior seating performance achieved with Kel-F® soft seat technology.

## CONSTRUCTION

Bronze or stainless steel body, bronze or stainless steel valve seat, Kel-F® seat disc, gylon gaskets, and stainless steel pressure springs. All parts are commercially cleaned for oxygen service. For details of construction materials, see List of Materials on Page 4.

Built-in conformance to ASME Code Section VIII for Cryogenic Service.

Reseating Pressure: 90% of set pressure

Rated Capacity: 110% of set pressure

Temperature Rating: +150°F to -320°F

Pressure Range:

1/2" to 1" size 15-600 psig  
 1 1/4" to 2" size 15-500 psig

## APPLICATIONS

The Type C776 safety relief valve protects piping, storage tanks, and process equipment utilized in the distribution of industrial gases against damage caused by the expansion of liquified gases. Ideal for oxygen, nitrogen, argon, carbon dioxide, helium, hydrogen and other industrial gases.

## FEATURES

- Approved and rated by National Board to ASME Code Section VIII
- Ideal for cryogenic service to -320°F
- Kel-F® seat disc ensures positive reseating and leak tight seal in accordance with accepted industry standards
- Full lift maximum discharge capacity
- Unobstructed flow through top guided design
- Pressure tight dome



### C776 Pressure Ranges

VALVE SIZE	SPRING RANGES - psi
1/2" x 3/4"	15-25, 25-35, 35-46, 46-61, 61-80, 80-105, 105-135,
1/2" x 1"	135-185, 185-250, 250-315, 315-435, 435-500, 500-600
3/4" x 1"	
3/4" x 1 1/4"	15-25, 25-37, 37-46, 46-58, 58-73, 73-92, 92-110,
1" x 1 1/4"	110-120, 120-180, 180-250, 250-325, 325-390, 390-435, 435-500, 500-600
1 1/4" x 1 1/2"	15-25, 25-38, 38-46, 46-57, 57-70, 70-90, 90-115, 115-130, 130-175, 175-200, 200-300, 300-400, 400-500
1 1/2" x 2"	15-24, 24-47, 37-53, 53-70, 70-84, 84-101, 101-120 120-150, 150-170, 170-220, 220-300, 300-400, 400-500
2" x 2 1/2"	15-25, 25-40, 40-57, 57-74, 74-98, 98-130, 130-150, 150-205, 205-258, 258-300, 300-400, 400-500

Note: New higher spring ranges now available.

# CRYOGENIC SAFETY RELIEF VALVE

## SPECIFICATIONS - CAPACITY (AIR CAPACITY IN SCFM BY SIZE - AMBIENT TEMPERATURE)

SET PRESSURE psig	1/2" X 3/4"	1/2" X 1" 3/4" X 1"	3/4" X 1 1/4"	1" X 1 1/4"	1 1/4" X 1 1/2"	1 1/2" X 2"	1 1/2" X 2 1/2"
15	75	75	215	215	285	452	736
20	86	86	248	248	329	522	849
30	109	109	313	313	416	660	1074
40	134	134	385	385	512	812	1322
50	159	159	458	458	607	964	1570
60	184	184	530	530	703	1117	1818
70	209	209	602	602	799	1269	2065
80	235	235	674	674	895	1421	2313
90	260	260	747	747	991	1573	2561
100	285	285	819	819	1087	1725	2809
110	310	310	891	891	1183	1877	3056
120	335	335	963	963	1278	2030	3304
130	360	360	1036	1036	1374	2182	3552
140	385	385	1108	1108	1470	2334	3799
150	410	410	1180	1180	1566	2486	4047
160	435	435	1252	1252	1662	2638	4295
170	461	461	1324	1324	1758	2790	4543
180	486	486	1397	1397	1854	2943	4790
190	511	511	1469	1469	1949	3095	5038
200	536	536	1541	1541	2045	3247	5286
210	561	561	1613	1613	2141	3399	5534
220	586	586	1686	1686	2237	3551	5781
230	611	611	1758	1758	2333	3704	6029
240	636	636	1830	1830	2429	3856	6277
250	662	662	1902	1902	2525	4008	6525
260	687	687	1974	1974	2620	4160	6772
270	712	712	2047	2047	2716	4312	7020
280	737	737	2119	2119	2812	4464	7268
290	762	762	2191	2191	2910	4617	7516
300	787	787	2263	2263	3004	4769	7763
310	812	812	2336	2336	—	—	—
320	837	837	2408	2408	—	—	—
330	862	862	2480	2480	—	—	—
340	888	888	2552	2552	—	—	—
350	913	913	2624	2624	—	—	—
360	938	938	2697	2697	—	—	—
370	963	963	2769	2769	—	—	—
380	988	988	2841	2841	—	—	—
390	1013	1013	2913	2913	—	—	—
400	1038	1038	2986	2986	—	—	—

Discharge capacities in standard cubic feet per minute of air at 110% of set pressure or set pressure +3 psi, whichever is greater.

GAS	OXYGEN	NITROGEN	HYDROGEN	HELIUM	CO <sub>2</sub>	ARGON	METHANE
Factor	1.05	0.98	0.26	0.37	1.24	1.18	0.74

1. For gases other than air, multiply the required gas flow for your gas by the appropriate factor above to obtain the equivalent air flow. Then use the capacity chart above for determining valve size.

2. To find the gas flow equivalent to the air flow given in the above chart, divide the chart flow by the appropriate factor above.

Capacity data based on a maximum back pressure of 10%.

# TYPE C-776

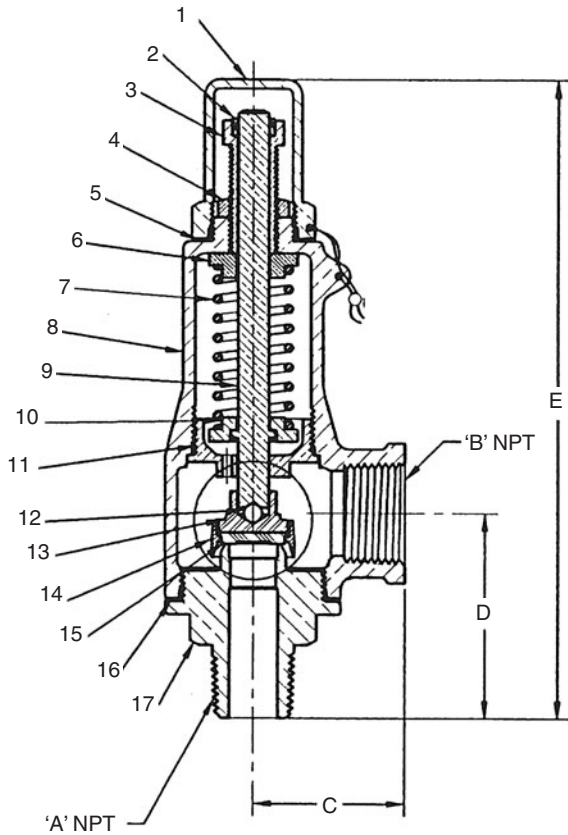

## LIST OF MATERIALS

ITEM	QTY.	DESCRIPTION	MATERIAL
1	1	Adj. Screw Cap	Brass ASTM B16/ASTM A479 SS
2	1	Bushing	Virgin PTFE
3	1	Adjusting Screw	Brass ASTM B16/ASTM A479 SS
4	1	Lock Nut	Brass ASTM B16/ASTM A479 SS
5	1	Gasket	Gylon PTFE
6	1	Spring Button	Brass ASTM B16/ASTM A479 SS
7	1	Spring	SS
8	1	Body	Brass ASTM B62/ASTM A351/351M CF 8M
9	1	Pull Rod	Brass ASTM B16/ASTM A479 SS
10	1	Pressure Plate	Brass ASTM B16/ASTM A479 SS
11	1	Guide Bushing	Brass ASTM B16/ASTM A479 SS
12	1	Ball	Monel®
13	1	Seat Stem	Monel® ASTM B164/ASTM A479 SS
14	1	Seat Shell	Brass ASTM B16/ASTM A479 SS
15	1	Seat Disc	PCTFE Kel-F®
16	1	Gasket	Gylon PTFE
17	1	Body Seat	Brass ASTM B16/ASTM A479 SS

## DIMENSIONS

VALVE SIZE	INLET SIZE A	OUTLET SIZE B	C INCHES	D INCHES	E INCHES	F ORIFICE INCHES	ORIFICE AREA	WEIGHT - LB.
1/2"	1/2"	3/4"	1.57	2.06	6.81	0.465	0.169	2.2
1/2"	1/2"	1"	1.77	2.06	6.81	0.465	0.169	2.2
3/4"	3/4"	1"	1.77	2.06	6.81	0.465	0.169	2.2
3/4"	3/4"	1 1/4"	2.17	2.42	9.09	0.787	0.486	3.5
1"	1"	1 1/4"	2.17	2.87	9.49	0.787	0.486	3.5
1 1/4"	1 1/4"	1 1/2"	2.36	3.07	10.43	0.906	0.645	4.6
1 1/2"	1 1/2"	2"	2.76	3.31	12.72	1.142	1.024	8.8
2"	2"	2 1/2"	3.19	3.74	14.61	1.457	1.667	15.4

## HOW TO ORDER

Specify Cash Valve Type C776 and state the following:

1. Valve size
2. Service – type of gas and temperature
3. Inlet and outlet connection
4. Pressure setting
5. Capacity requirements – maximum
6. System working pressure

Cash Valve  
 953 Old U.S. Highway 70  
 Black Mountain, NC 28771  
 Phone: 800-879-2042 • 828-669-3710  
 Fax: 800-879-2057 • 828-669-0586  
 CAVMC-0515-US-0208

**Tyco Valves & Controls**  
 www.cashvalve.com