



Cipriani Harrison Valves Corp.

Check Valve 64 Series

Application

Check valves also known as “non return valves” are designed for use in process piping installations to prevent reverse flow.

Working Principle

A check valve opens when the pressure below the valve plug exceeds the pressure above the valve plug and the spring force. The valve closes when pressure equalization has been achieved.

Standard Design

The forged stainless steel valve body ensures non porous, smooth surfaces and dimensionally stable construction. The valve body is in two parts, assembled by means of a standard clamp and sealed with a standard gasket. The self draining design of the lower valve body enables flushing of the product. Ribbed construction of the stainless steel disc resists heavy pressure hammer, minimizes the resistance to flow and also serves as a guide to the valve plug. All Seats and Seals are made from FDA approved materials.

Available Sizes

1", 1 1/2", 2", 2 1/2", 3", 4"

Options

End connections: Sanitary Clamp, Butt-Weld, I-Line or others on request.

Material : AISI 316L or AISI 304L

Springs : Stronger springs are available for higher pressures.

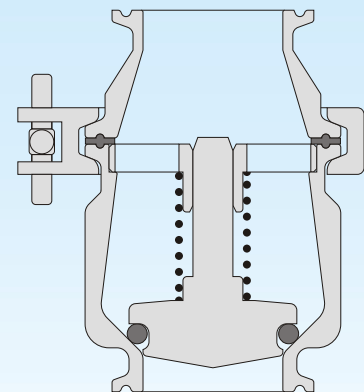

 *Cipriani Harrison Valves Corp.*

30271 Tomas Street • Rancho Santa Margarita, CA 92688 • Tel. 949/589-3978 • Fax 949/589-3979
Email : cipriani@ciprianicorp.com • Website : <http://www.ciprianicorp.com/>

Check Valve

64 Series

TECHNICAL SPECIFICATIONS :

Material :

Product wetted steel parts.....AISI 316L or AISI 304L
Other steel parts.....AISI 304

FDA Seals :

O'Ring.....PTFE
Gasket.....SILICONE

Nominal Pressure :

Maximum product pressure.....150 PSI maximum (10 Bars)
Standard Cracking pressure.....6 PSI (0.4 Bars)
Optional Cracking pressure.....3 PSI (0.2 Bars)
10 PSI (0.7 Bars)
* For Additional Cracking pressures
Consult the factory

Temperature & Chemical Compatibility :

Please refer to the temperature and chemical compatibility charts located in the General Information section of the catalog. Temperature & Chemical Compatibility are limited by the seal material.

Surface Finish :

Surface in contact with product...Ra \leq 25 μ in (Grit 220g)
Optional.....Ra \leq 15 μ in (Grit 320g)
* Electropolishing available upon request

ConnectionsSanitary Clamp (ISO 2852 / BS 4825-3)
Optional.....Butt Weld (ISO 2037 / BS 4825-1)
I-Line
Other connections on request

Pressure drop/capacity diagram

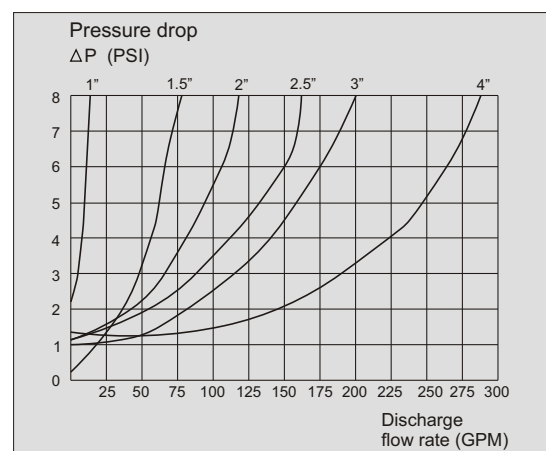

 **Cipriani Harrison Valves Corp.**

30271 Tomas Street • Rancho Santa Margarita, CA 92688 • Tel. 949/589-3978 • Fax 949/589-3979
Email : cipriani@ciprianicorp.com • Website : <http://www.ciprianicorp.com/>

Check Valve

64 Series

Dimensions (Inches)

Butt-Weld

Dimensions	1"	1½"	2"	2 ½"	3"	4"
A	3 3/4	3 3/4	4 3/64	4 13/32	4 31/32	5 3/8
B	2	2 17/32	3 1/64	3 19/32	4 11/16	5 5/64
OD	1	1 ½	2	2 ½	3	4
ID	7/8	1 3/8	1 7/8	2 3/8	2 55/64	3 27/32

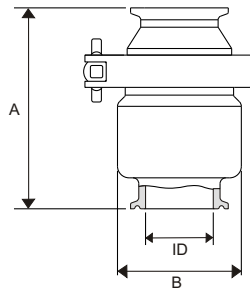
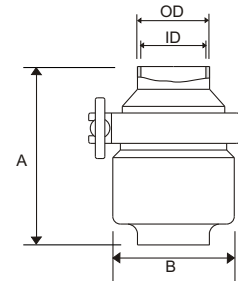

Sanitary Clamp

Dimensions	1"	1½"	2"	2 ½"	3"	4"
A	3 3/4	3 3/4	4 3/64	4 13/32	4 31/32	5 3/8
B	2	2 17/32	3 1/64	3 19/32	4 11/16	5 5/64
ID	7/8	1 3/8	1 7/8	2 3/8	2 55/64	3 27/32

I-Line

Dimensions	1"	1½"	2"	2 ½"	3"	4"
A	4 1/4	4 1/4	4 51/64	5 5/32	5 35/64	6 25/64
B	2	2 17/32	3 1/64	3 19/32	4 11/16	5 5/64
ID	7/8	1 3/8	1 7/8	2 3/8	2 55/64	3 27/32

* Consult the factory for I-line Male x Male or I-line Female x Female "A" Dimensions.

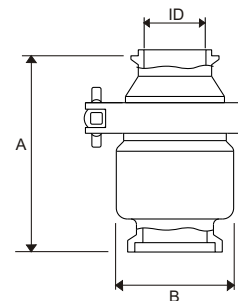

30271 Tomas Street • Rancho Santa Margarita, CA 92688 • Tel. 949/589-3978 • Fax 949/589-3979

Email : cipriani@ciprianicorp.com • Website : <http://www.ciprianicorp.com/>

Check Valve

64 Series

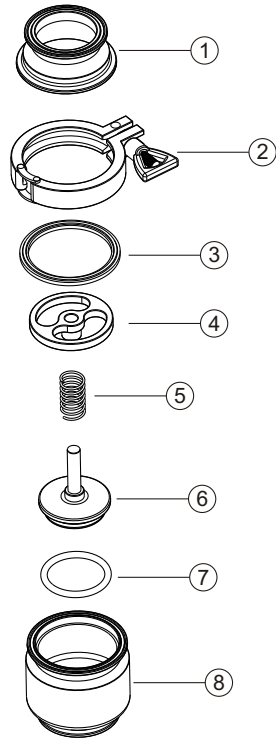

Exploded view of standard Check Valve

NO.	PART NUMBER	DESCRIPTION	MATERIAL
1	6401	UPPER VALVE BODY	AISI 316L / AISI 304L
2	6402	CLAMP	AISI 316L / AISI 304L
3	6403	GASKET	SILICONE
4	6404	DISC PLATE	AISI 316L / AISI 304L
5	6405	SPRING	AISI 316L / AISI 304L
6	6406	VALVE SEAT/ PLUG	AISI 316L / AISI 304L
7	6407	O'RING SEAL	PTFE
8	6408	LOWER VALVE BODY	AISI 316L / AISI 304L

* Other gasket material available upon request.

64 Series Check Valve Ordering System

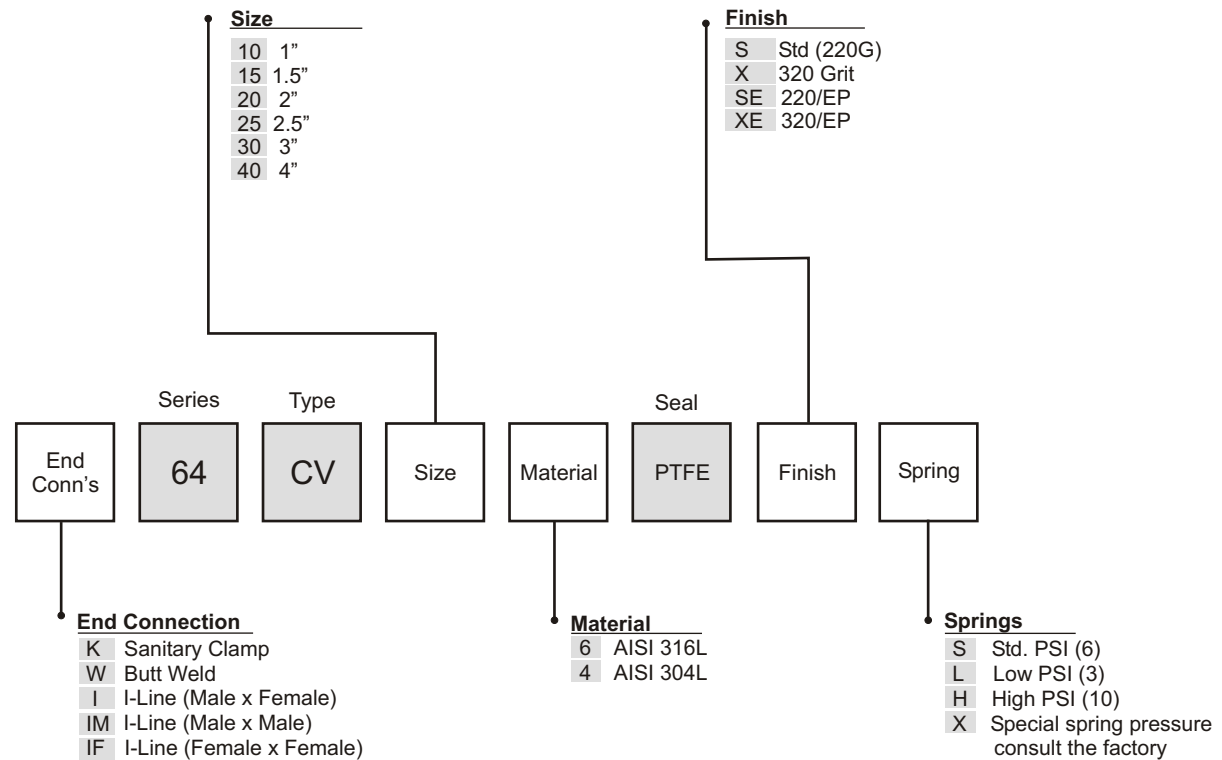

30271 Tomas Street • Rancho Santa Margarita, CA 92688 • Tel. 949/589-3978 • Fax 949/589-3979

Email : cipriani@ciprianicorp.com • Website : <http://www.ciprianicorp.com/>