



# *Sleeveline<sup>®</sup>*

*The Benchmark For Quality  
and Value*



*Non-Lubricated Plug Valves For Chemical Service*



Quality  
System  
Certificate

Bulletin V-24c (E)

# Durco® G4 Sleeve Valve

**F**lowserve invented the non-lubricated plug valve for the most corrosive and difficult chemical services where drop-tight shutoff is an absolute requirement. Nearly 50 years later there are many imitators but no substitute for the quality and reliability, versatility and value you receive with Sleeve Valve valves.

**Double D Plug Stem**  
Accepts most standard actuation equipment.

**Lockout**  
Meets OSHA and plant safety requirements.

**In-Line Adjustment**  
Prevents thru-line leakage.

**PTFE Sleeve**  
Large seal area offers positive shutoff and extended service life.

**Actuator Mounting Pads**  
Mounts directly on flanges for solid support.

**Tapered Plug**  
Assures reduced turning torque and in-line seal adjustment and wear. Adjustment is independent of stem seals. With  $\pm 3/16$  in ( $\pm 5$  mm) adjustment, plug cannot bottom out.

**PFA Reverse Lip Diaphragm**  
Provides static and dynamic, self-adjusting stem seal.

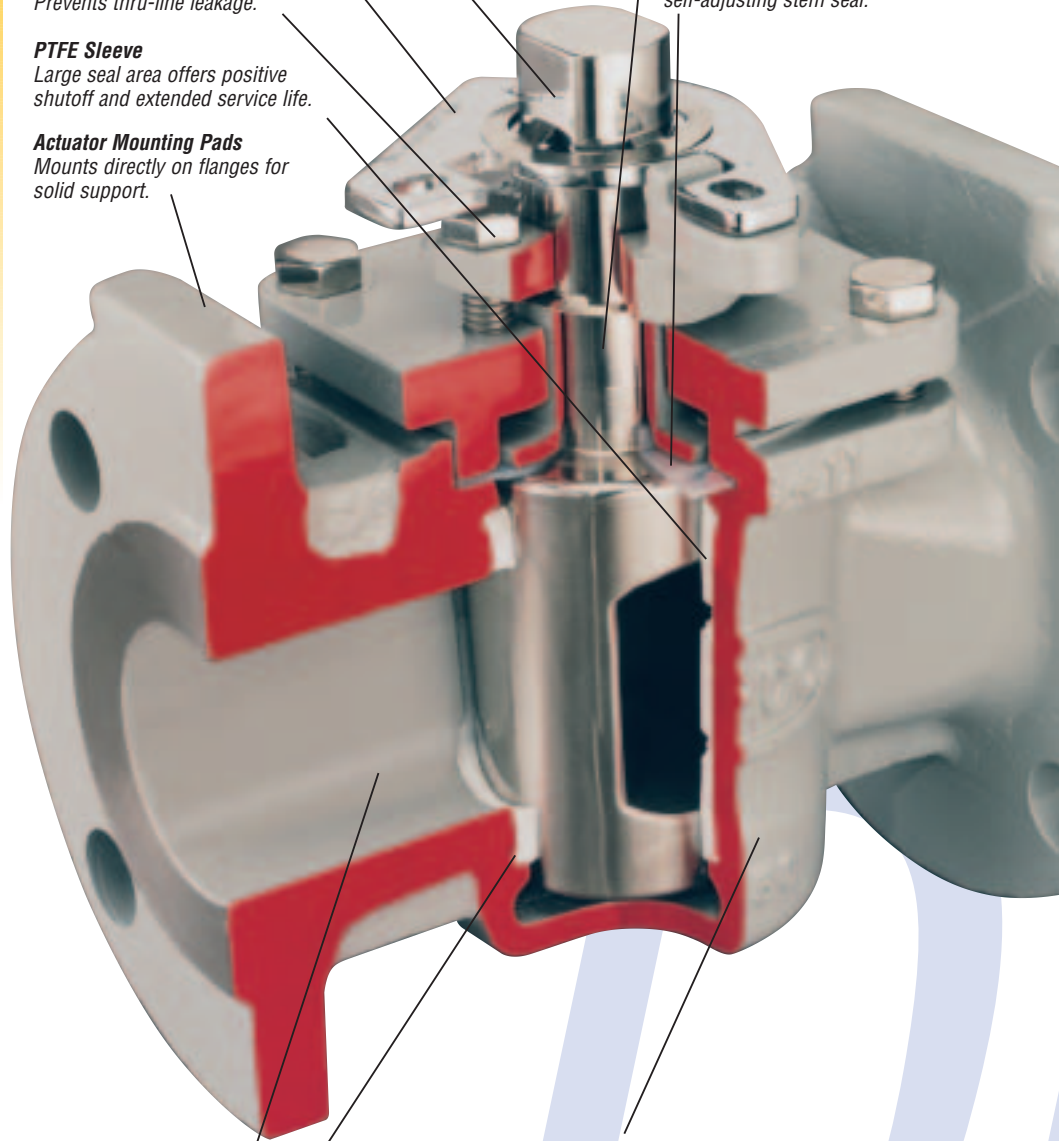

**Large Port Openings**  
Assure less pressure drop and higher  $C_v$ .

**Raised Locking Ribs**  
Along with grooves and recesses positively lock sleeve in body.

**Wide Materials Selection**  
Corrosion resistant stainless steels, nickel base and reactive alloys.

**Rugged, Heavy-Duty Body**  
Limited lifetime casting guarantee. ANSI (ASA) or DIN flanges standard. N.P.T. screwed, socket and butt weld available.

Rated to ANSI Class 150 lb and 300 lb designs at pressures to 740 psi (5102 kPa) and vacuum to 1 micron (0.133 kPa).

### **G4B Marathon™**

High cycle/low emission valve is durable, reliable and versatile.  
See pages 6 & 7

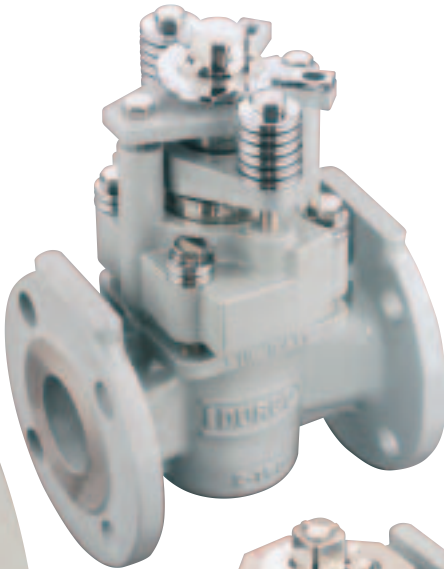

### **TSG4 Severe Service**

Effectively and economically meets emission requirements of the most demanding services.  
See pages 8 & 9



### **Special Configurations**

Sleeveline valves are available in special trim, multiport and lower torque models along with special end connections.  
See page 5

### **EG4 Control Valves**

Characterized plug available for modulating applications.  
See pages 10 & 11



## **G4 Seal System**

*All G4 Sleeveline valves offer the proven reliability of the plug/PTFE sleeve primary seal with a PFA diaphragm secondary seal.*

### **Positive Stem Seal**

The unique PFA reverse lip diaphragm provides a self-energizing dynamic stem seal where pressure activates the reverse lip to seal against the stem. It also provides a static seal by wedging against the stem with an interference fit.

### **Line Sealing**

The compressive, wedge fit of the tapered plug with the PTFE sleeve serves as the sealing surface. The sleeve totally surrounds plug ports and seals the circumference of the plug, top and bottom. There are no cavities to accumulate product. Sealing is both upstream and downstream.

- Seal is totally independent of line pressure.
- There is no metal-to-metal contact.
- Valve remains free-turning throughout its life and never requires lubrication.
- Seal is adjustable.
- Wiping action between sleeve and plug provides for good slurry handling.

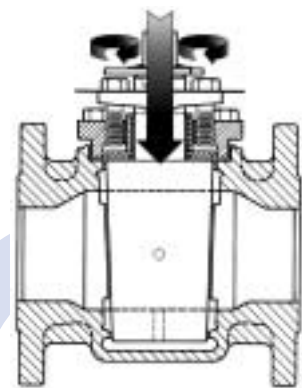

### **In-Line, Thru-Line Seal Adjustability**

In-line seal adjustment is achieved by turning two adjuster fasteners to drive the plug deeper into the sleeve. This saves maintenance and process time because the seal is adjusted in-line and under pressure within seconds. The result is repeatable, bubble-tight shutoff performance.



# Durco G4Z Fire Sealed

**D**urco SleeveLine valves have been fire tested in accordance with API 607 Fourth Edition. They surpassed the external sealing requirements of Section 4, Paragraph 4.2, "Performance Requirements."

G4Z Fire Sealed SleeveLine valves incorporate special Grafoil® packing rings at the stem and Grafoil gaskets at the top cap. These reduce atmospheric leakage to a negligible amount should fire destroy the PTFE sleeve and diaphragm. A metal diaphragm keeps the Grafoil packing in place if the top seal is destroyed.

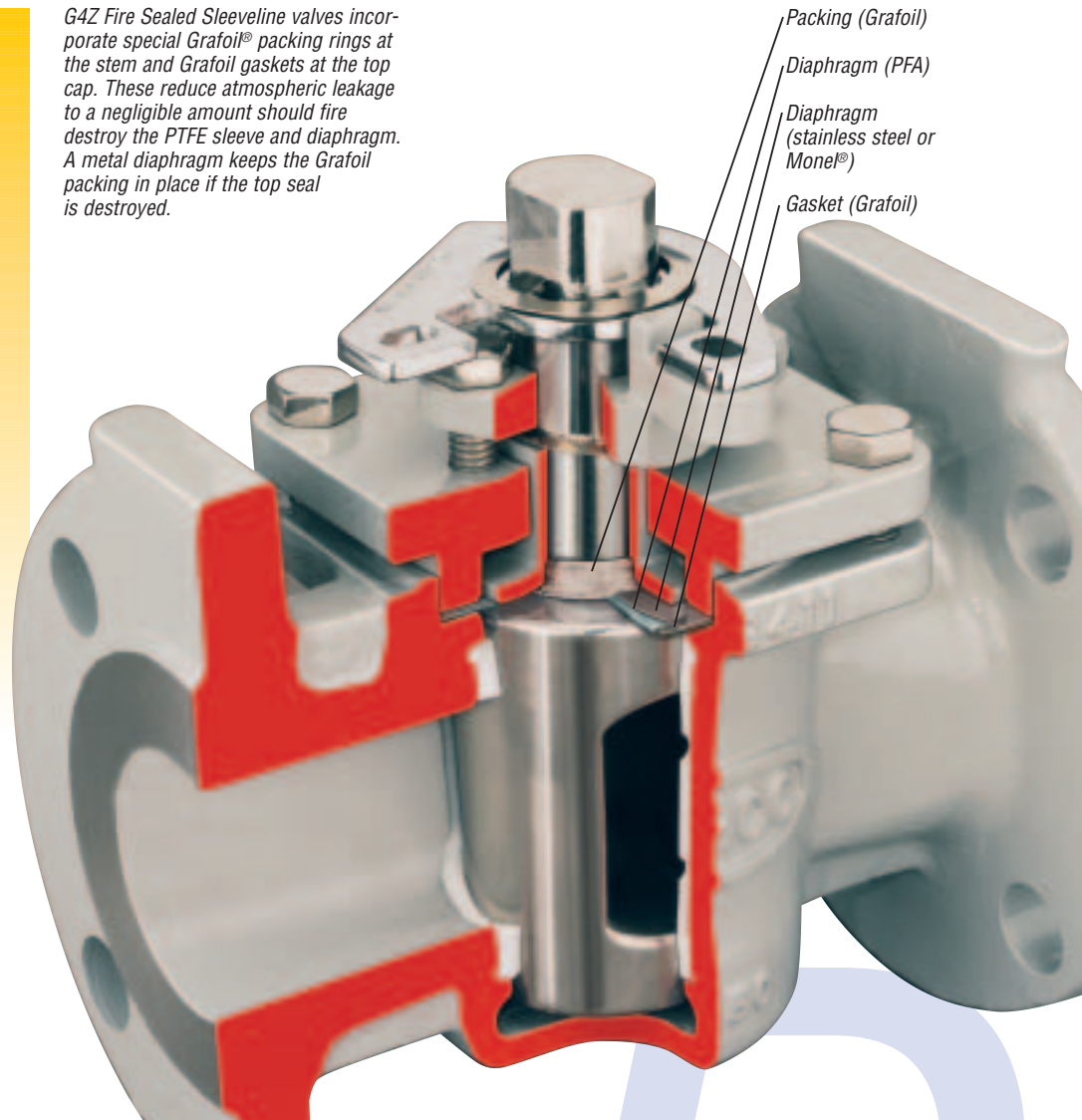

**G4Z-HF Alkylation Valves Are Phillips Licensing Listed and UOP Process Division Approved**

As an approved supplier for Phillips and UOP licensing, Flowserve has provided thousands of Durco HF alkylation valves to refineries throughout the world for services such as:

- Isomerization
- Blending
- Light ends
- Gas plant
- Sulfur plant
- Crude desalting

See Bulletin V-25 for complete information about available G4Z-HF valve sizes and configurations; technical specifications; and appropriate industry standards compliance.

® Grafoil is a registered trademark of Union Carbide.

® Monel is a registered trademark of the International Nickel Co., Inc.

# Special Configuration Valves

## **Chlorine Valves**

Designed especially for dry chlorine gas or liquid chlorine applications. All Durco G4 chlorine valves are supplied with a vented plug. This vents the chlorine safely towards the high pressure side.



## **Jacketed Valves**

For proven performance in critical temperature control situations, specify our FJG4 full cast jacket or the PJG4 welded partial jacket on Durco valves.



## **3-Way Valves**

Choose Durco Multiport process valves for mixing, safety and relief, switching bypass, and transflow services. Available in fully or partially jacketed models.



## **Special End Connections**

In addition to ANSI and DIN flanged designs, G4 SleeveLine valves are available with grooved end; screwed end; screwed/socket end; weld end; and butt weld end connections.

## **Lower Torque Valves Available**

For applications requiring lower torque, G4 valves (N models) in the 8 in (200 mm) thru 12 in (300 mm) sizes are available. Contact the factory for dimensional specifications.

**D**urco valves offer the process industries' widest range of non-lubricated plug valve models, materials and configurations. This provides customers the flexibility to specify SleeveLine valves to meet virtually all their applications needs.

# Durco G4B Marathon™

**T**he G4B Marathon is designed for reliable performance in high cycle on-off or modulating services. Fugitive emission containment is often equal to more expensive severe or toxic service valves.

**3-Year Performance Guarantee**  
Unprecedented limited warranty. The valve will be repaired or replaced if stem seal fails within 3 years after installation.

**Viton® O-rings**  
Full pressure containment stem seal. Also protects thrust collar from atmospheric corrosion. Kalrez® and other elastomers are available. PTFE backup rings help prevent extrusion of Viton O-rings under pressure.

**Smooth Sealing Surfaces**  
Highly polished surfaces eliminate wear and enhance seal integrity.

**Integral Thrust Collar/  
Alloy Diaphragm**  
Self-sealing, dynamic bellows-like diaphragm moves with plug adjustment to eliminate potential leak path. Hastelloy® (or optional materials) diaphragm welded to alloy thrust collar.

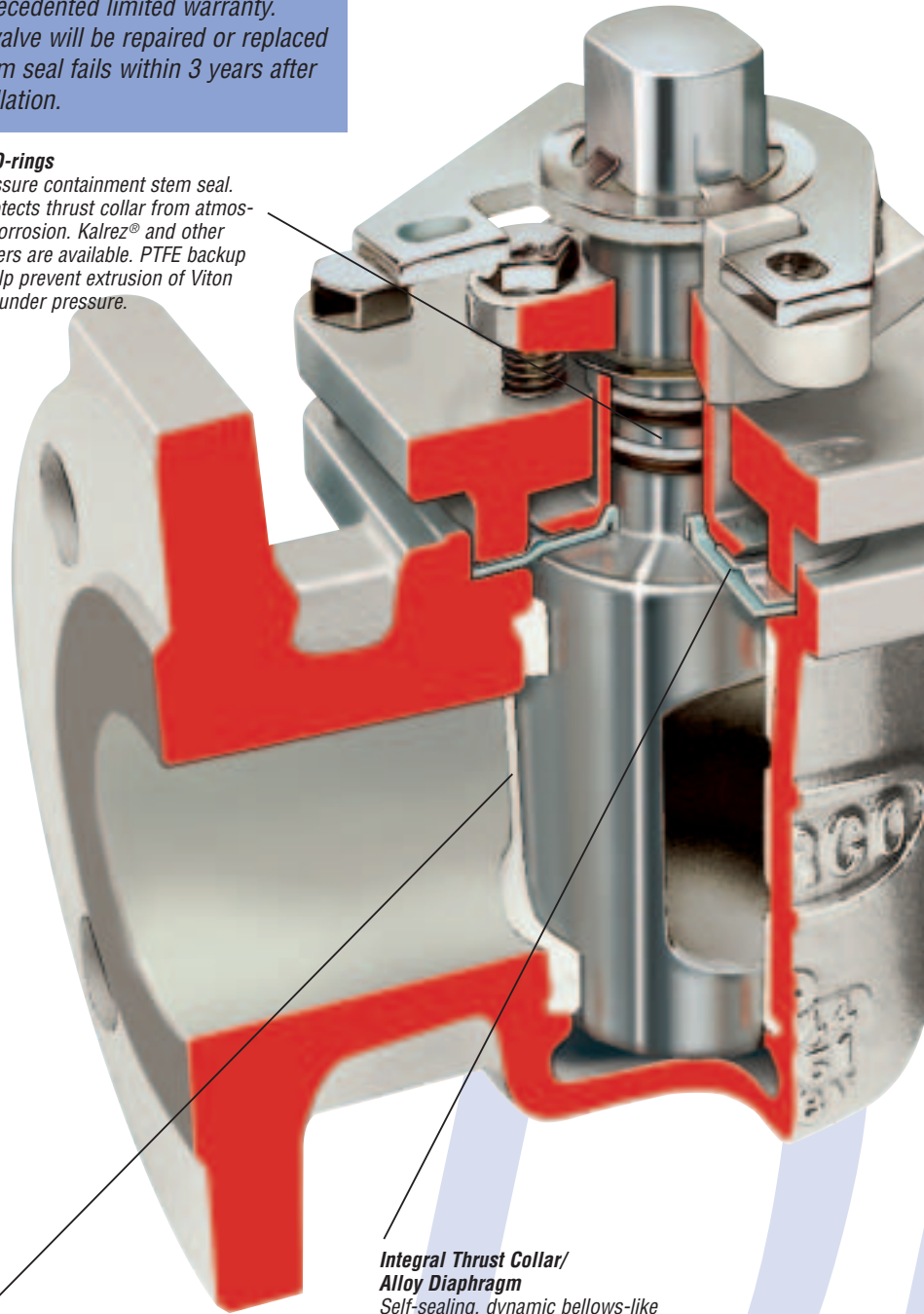



# High Cycle Positive Stem Sealing Durability



## Unique Stem-Sealing Design

The G4B Marathon valve can be used with confidence in chemical processing applications where tight shutoff and emissions containment are priority requirements. As a bonus, its very design assures long-lived, high cycle performance.

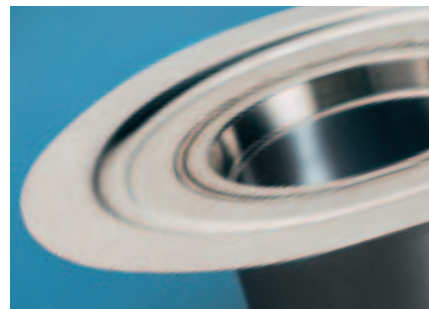

## New Welded Diaphragm

The integral thrust collar/alloy diaphragm is a third line of defense against leakage to the atmosphere. The underside of the metal bellows-like diaphragm acts as an expansion joint by allowing the PTFE diaphragm to adjust to plug movement and pressure changes. The Hastelloy C diaphragm provides an impermeable barrier to chlorine as well as many other services.

Available for G4Z, EG4, MG4 and G4J.

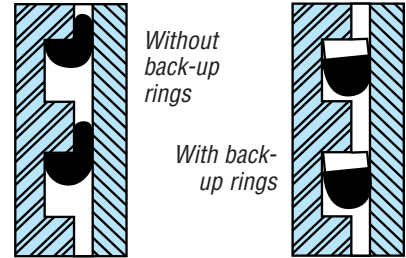

## Viton O-Rings

A pair of Viton O-rings prevents stem leakage while containing line pressure. They also protect the thrust collar against attack from atmospheric corrosion. PTFE back-up rings firmly lock the Viton O-rings in the stem grooves and serve as anti-extrusion devices.

Optional Kalrez O-rings are available for special services.

## Proven High Cyclability

Lab and field tests have proven that the G4B Marathon can cycle as many as three-to-five times more than a standard PTFE sleeved quarter-turn valve before it begins to show stem seal wear.

## G4EB Marathon Valve

Viton o-rings & welded metal diaphragm stem seals  
Sleeve & Diaphragm cut in four places

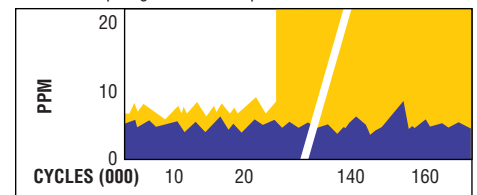

Conventional Plug Valve >2000 PPM

G4EB Valve

## Passing The Test

Lab technicians defeated the PTFE sleeve and PFA diaphragm, the G4B's primary and secondary stem seals, by cutting both of them in four places. They operated the valve to 160,000 cycles. Rather than using the standard Method 21 methane emissions test, they chose the more demanding helium emissions test. The results were impressive.

# Durco TSG4 Severe Service

**T**riple sealed valve for lethal, toxic and sub-zero fluid services where an absolute stem seal is required. Meets/exceeds federal Clean Air Act fugitive emissions regulations at one-third to one-half the cost of bellows sealed valves.

A true stuffing box design, the TSG4 easily handles the toughest services such as chlorine, anhydrous HCl and hydrofluoric acid. It possesses all the positive shutoff, corrosion resisting features and benefits of other Durco SleeveLine valves.

### Triple Sealed

#### Primary

PTFE sleeve provides large static seal area for positive shutoff and extended service life.

#### Secondary

PFA reverse lip diaphragm offers static and dynamic self-adjusting stem sealing assurance.

#### Tertiary

Live-loaded PTFE packing set further prevents potential emissions while addressing possible permeation related leakage.

#### Belleville Washers

Accommodate extreme temperature fluctuations.

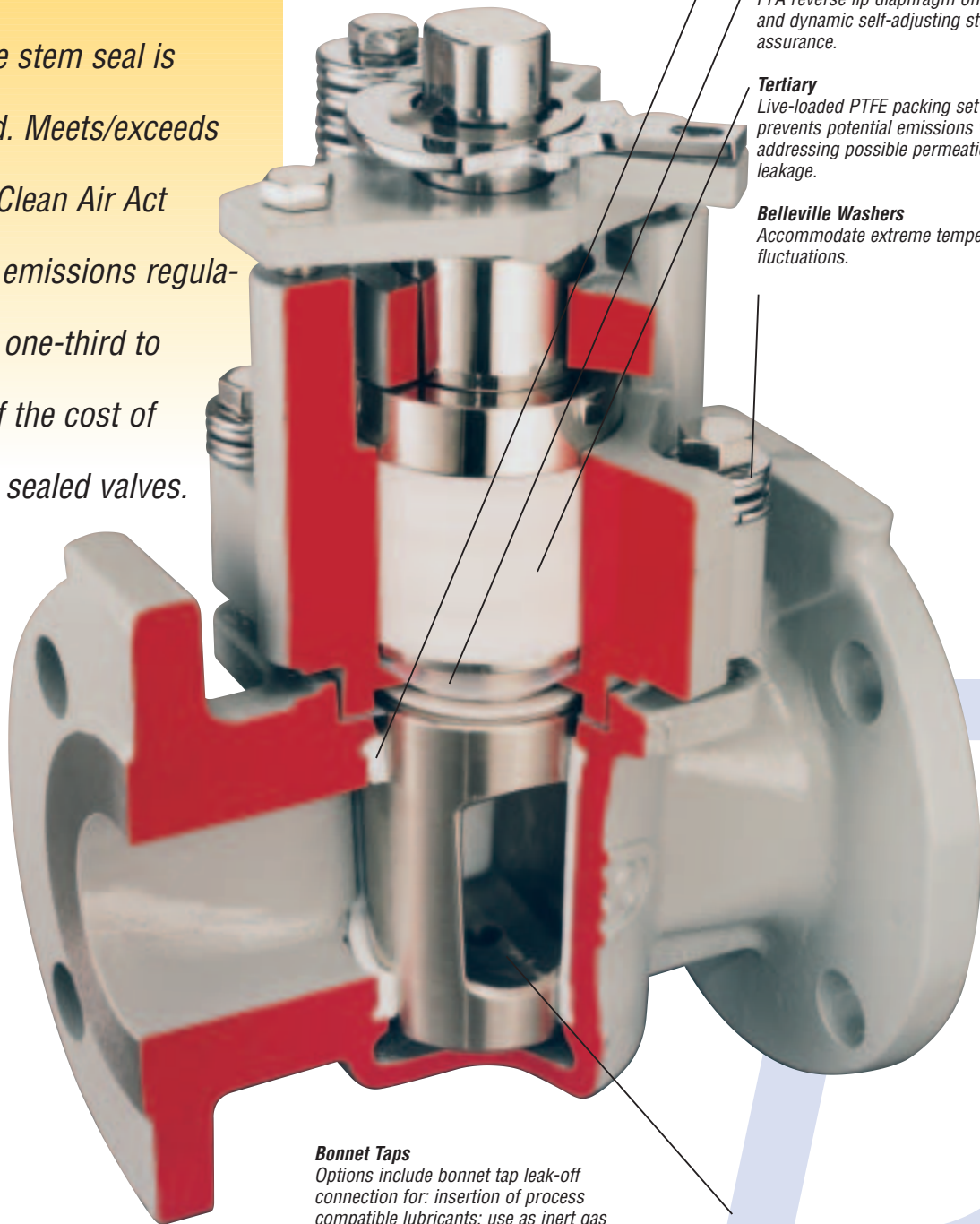

### Bonnet Taps

Options include bonnet tap leak-off connection for: insertion of process compatible lubricants; use as inert gas pad; or where remote monitoring of highly critical processes is required.

### Drilled and Vented Plug

Balances pressure between the plug port and body cavity



**Wide Range of Stuffing Box Options with Independent Plug and Stem Seal Adjustments**

The TSG4 offers broad flexibility in choosing the packing set and design options best suited to your service requirements. Choose from a variety of stem seals that lets you enjoy:

- Triple seal protection from fugitive emissions
- The sealing and long-term service benefits of the PFA reverse lip diaphragm
- Independent plug and stem sealing adjustment
- Thermal cycling capability with live-loaded fasteners using Belleville washers with PTFE packing only
- Leak-off connections for continuous monitoring

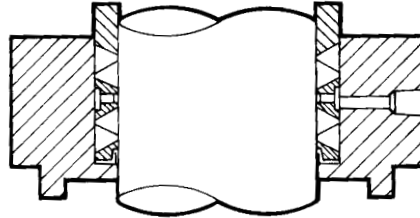

Preformed PTFE cup and cone with lantern ring and reverse lip diaphragm

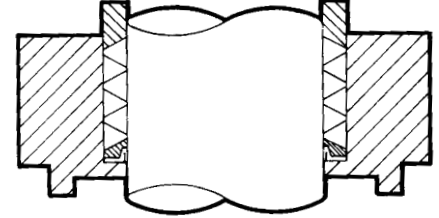

Preformed PTFE cup and cone with reverse lip diaphragm

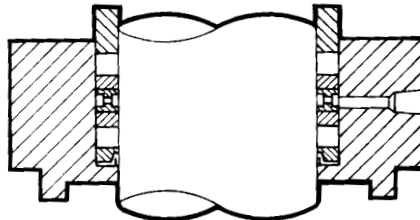

Compression fire seal packing set die formed flexible graphite rings and lantern ring between braided Grafoil with reverse lip diaphragm

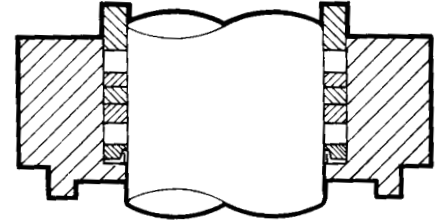

Compression fire seal packing set die formed flexible graphite rings between braided Grafoil with reverse lip diaphragm

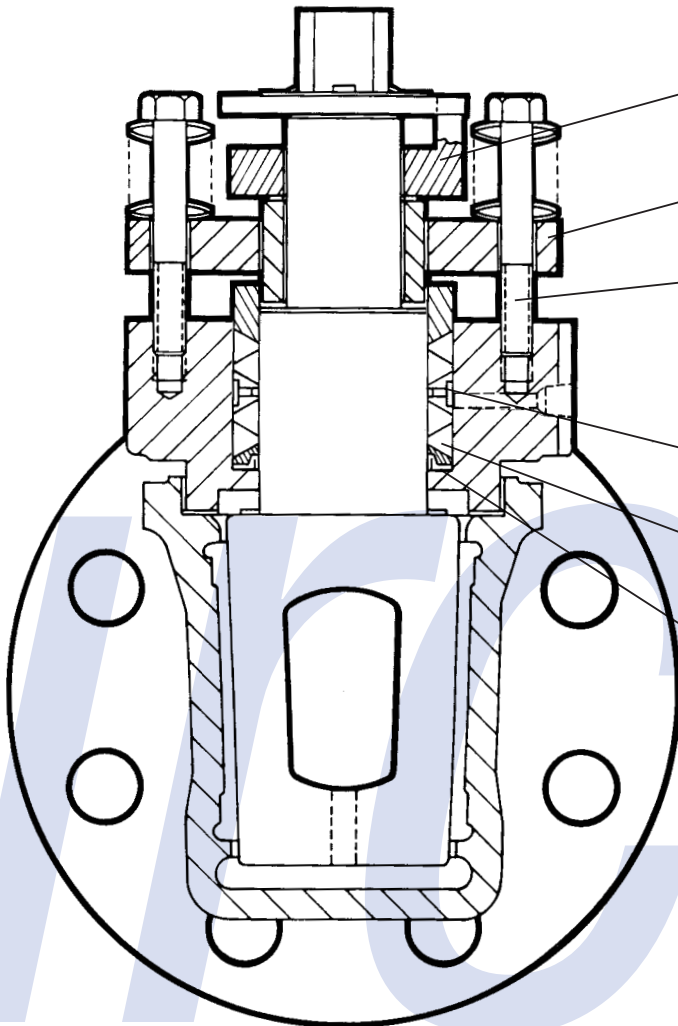

**Plug Adjuster**

Provides separate and positive, in-line plug/seat adjustment for wear.

**Packing Adjuster**

Independent packing set adjustment prevents stem seal emissions.

**Packing and Top Cap Adjuster Fasteners**

Live-loading of the packing adjuster and top cap fasteners ensure integrity of stem and bonnet despite fastener elongation due to temperature swings.

**Leak-Off Connection**

Optional feature helps detect fugitive emissions in the packing chamber.

**Cup and Cone Packing**

Live-loaded PTFE packing prevents stem leakage on both vacuum and positive pressure services.

**Reverse Lip Diaphragm**

Provides long-term cycling capability with its superior static/dynamic stem sealing.

# Durco EG4 V-Port Control Valves

*In addition to the features and benefits that have made SleeveLine the process industry's premier plug valve, Flowserve offers the EG4 V-Port valve for precise modulating control services.*

Durco EG4 V-Port control valves are available in a variety of trim configurations to satisfy your exact flow control needs. Sizes include 1 in (25 mm) through 6 in (150 mm) with full open  $C_v$  values of 3.0 to 400.

Specially trimmed EG4 V-Port SoundTrim® control valves reduce noise, cavitation and flashing while improving flow and pressure performance. STEG4 SoundTrim plugs are available for 1 in (25 mm), 2 in (50 mm) and 3 in (75 mm) valve sizes. Unique self-cleaning design prevents particulate build-up and clogging.

**Characterized v-port SleeveLine control valves are available as follows:**

- G4 – 1/2 in (5 mm) through 6 in (150 mm)
- G4B – 1/2 (5 mm) through 6 in (150 mm)
- TSG4 – 1 in (25 mm) through 3 in (75 mm)

**A Typical Characteristic Curve for EG4 V-Port Valves**

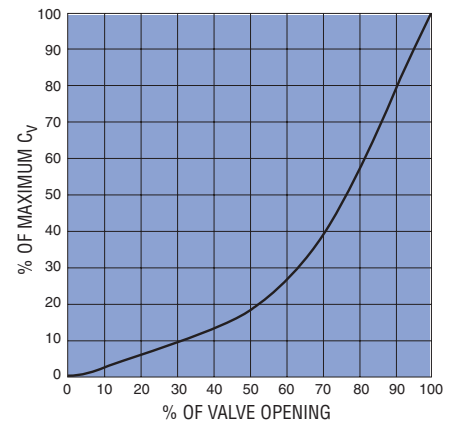

Refer to the Durco Technical Manual for valve and actuator sizing.



# Actuation Options For SleeveLine Valves

## Manual Operation

All Durco SleeveLine valves are fitted with a hand wrench as standard for manual operation. A gearbox option is also available for valve sizes 4 in (100 mm) and above.

## Actuation

Flowserve's Automax® operation is a specialist in valve automation systems offering rack and pinion, heavy-duty and electric actuators along with positioners, limit switches, engineered special control circuits and related accessories.

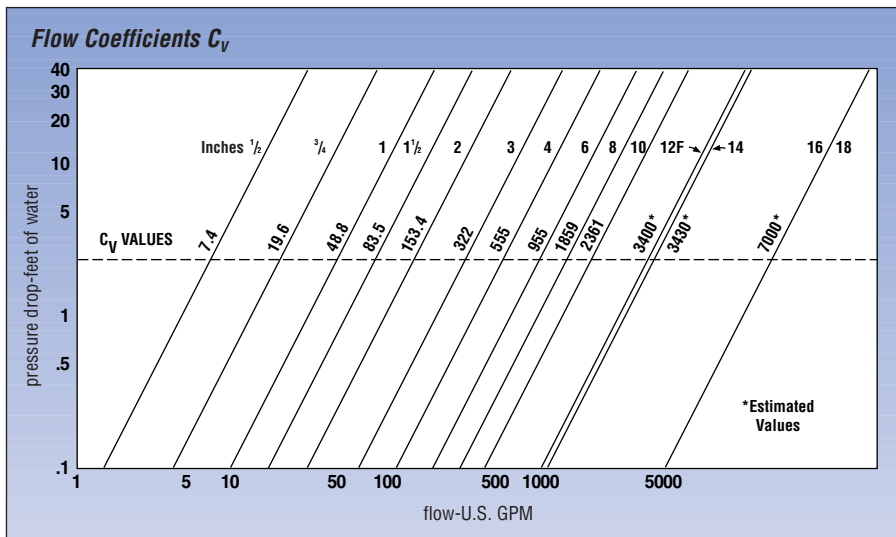
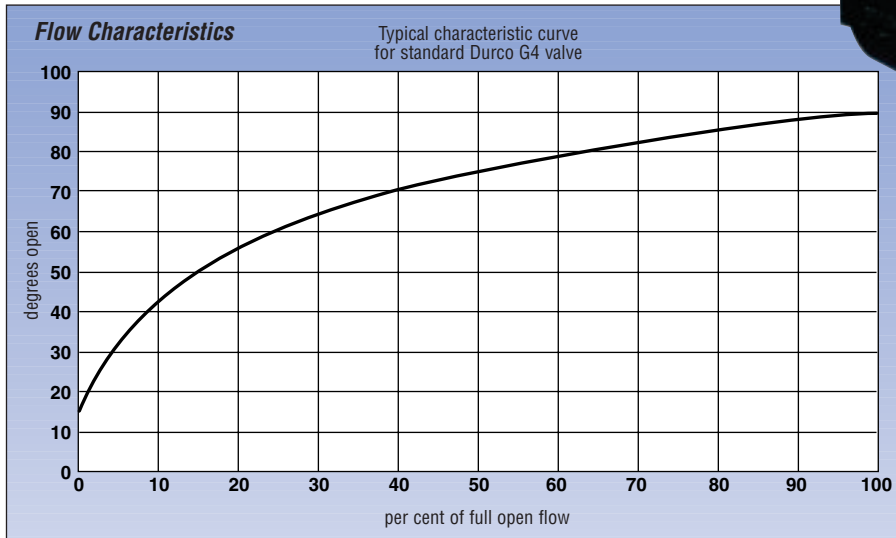

## Average Turning Torque Ft-Lbs\* (Joules)

Valve Size in (mm)	Torque At Plug Stem	Torque At Gear Wheel
1/4 (5)	3.0 (4.0)	—
3/8 (10)	3.0 (4.0)	—
1/2 (15)	3.0 (4.0)	—
3/4 (20)	3.0 (4.0)	—
1 (25)	7.0 (9.4)	—
1-1/2 (40)	8.0 (10.8)	—
2 (50)	13.0 (17.5)	—
3 (75)	19.0 (25.6)	—
4 (100)	54.0 (72.9)	5 (6.7)
6 (150)	140.0 (189.0)	8 (10.8)
8 (200)	306.0 (413.0)	16 (21.6)
10 (250)	580.0 (783.0)	35 (47.3)
12 (300)	610.0 (827.0)	16 (21.6)
14 (350)	610.0 (827.0)	16 (21.6)
16 (400)	1170.0 (1587.0)	18 (24.4)
18 (450)	1170.0 (1587.0)	18 (21.4)

\*Since starting or breakway torque is higher than turning torque, these values should not be used for actuator sizing. Consult your Durco Control Valve Manual or your Flowserve Sales Engineer for actuator sizing values.

All  $C_v$  values are measured in accordance with the Fluids Control Institute Standard 58-2.



# G4 & G4B Straightway Valve Dimensions

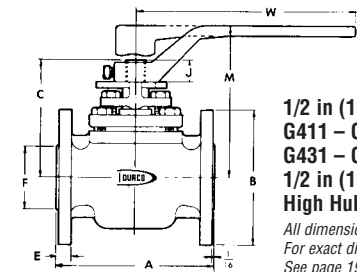

1/2 in (15 mm) thru 4 in (100 mm)  
**G411 – Class 150**  
**G431 – Class 300**  
 1/2 in (15 mm) - 3 in (75 mm) Offset Wrench Standard  
 High Hub Wrench Optional

All dimensions are approximate and for illustration purposes only.  
 For exact dimensions request certified dimensional prints.  
 See page 19 for (L) dimensions.

**Stem Configuration**

1/2 in (15 mm) to 6 in (150 mm) flats

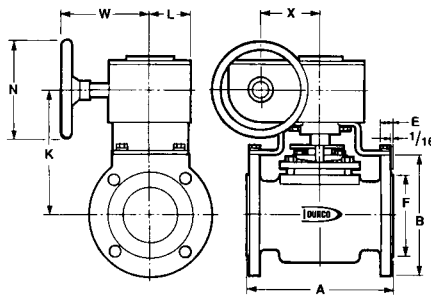

4 in (100 mm) and 6 in (150 mm)

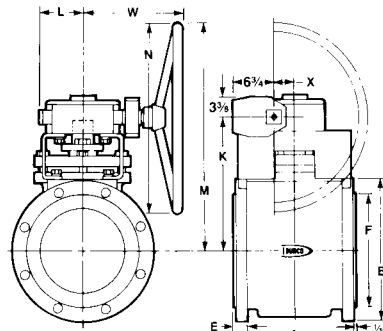

8 in (200 mm) thru 14 in (350 mm)  
**G411H – Class 150**

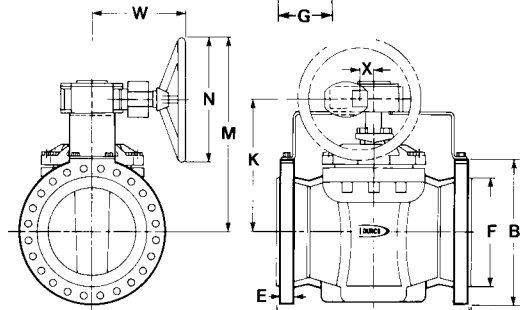

8 in (200 mm) thru 18 in (450 mm)  
**G431H – Class 300**

**English Units**

Valve Size	Drilling Class 150			Drilling Class 300			A		B		C	E		F	G	H	J	K	M		N	W	X	Area of Port Sq In	% Port Open	Wt. In Lbs.**											
	No.	Size	BC	No.	Size	BC	Class		Class			Class							150	300						150	300	150	300	150	300	150	300	150	300	150	300
							150	300	150	300		150	300																								
1/2	4	5/8	23/8	4	5/8	25/8	4 1/4	5 1/2	3 1/2	3 7/8	33/16	7/16	9/16	13/8	17/32	7/16	23/32	-	425/32	425/32	-	6	-	.248	126	6 1/2	73/4										
3/4	4	5/8	23/4	4	3/4	3 1/4	4 5/8	6	4	4 3/4	33/16	7/16	5/8	1 11/16	17/32	7/16	23/32	-	425/32	425/32	-	6	-	.248	56	7	10										
1	4	5/8	3 1/8	4	3/4	3 1/2	5	6 1/2	4 1/4	4 7/8	3 23/32	7/16	11/16	2	25/32	21/32	7/8	-	4 13/16	4 13/16	-	7	-	.785	100	10 3/4	17 1/4										
1 1/2	4	5/8	3 7/8	4	7/8	4 1/2	6 1/2	7 1/2	5	6 1/8	45/32	9/16	13/16	2 7/8	25/32	21/32	15/16	-	5 1/2	5 1/2	-	9	-	1.21	68	15 1/2	26										
2	4	3/4	4 3/4	8	3/4	5	7	8 1/2	6	6 1/2	4 3/4	5/8	7/8	3 5/8	11/16	7/8	1	-	6 5/16	6 5/16	-	12	-	2.0	64	23 1/2	29 1/2										
2 1/2	4	3/4	5 1/2	8	7/8	5 7/8	7 1/2	9 1/2	7	7 1/2	6	1 1/16	1	4 1/8	1 1/16	7/8	1 3/16	-	7 1/2	-	-	18	-	4.6	93	38	-										
3	4	3/4	6	8	7/8	6 5/8	8	11 1/8	7 1/2	8 1/4	6	3/4	1 1/8	5	1 1/16	7/8	1 3/16	-	7 1/2	7 1/2	-	18	-	4.6	65	41	69										
4W.O.	8	3/4	7 1/2	8	7/8	7 7/8	9	12	9	10	7 21/32	15/16	1 1/4	6 3/16	1 11/16	1 27/64	19/16	-	9 1/32	9 1/32	-	30	-	7.4	59	75	143 3/4										
4G.O.	8	3/4	7 1/2	8	7/8	7 7/8	9	12	9	10	-	15/16	1 1/4	6 3/16	1 11/16	1 27/64	19/16	8 3/8	19 1/2	19 1/2	12	8 13/16	3	7.4	59	93 3/4	162 1/2										
6G.O.	8	7/8	9 1/2	12	7/8	10 5/8	10 1/2	15 7/8	11	12 1/2	-	1	1 7/16	8 1/2	1 7/8	1 27/64	15/8	10 3/8	21 1/2	21 1/2	12	8 13/16	3	16.1	57	149 3/4	229 1/2										
8G.O.	8*	7/8	11 3/4	12	1	13	11 1/2	16 1/2	13 1/2	15	-	1 1/8	1 5/8	10 5/8	Splined	1 23/32	13 1/8	22 1/8	-	18	16	5/16	26.4	52	262	328											
10G.O.	12*	1	14 1/4	16	1 1/8	15 1/4	13	18	16	17 1/2	-	1 3/16	1 7/8	12 3/4	Splined	2 23/32	15 5/16	24 5/16	-	18	16	15/16	40.9	52	398	455											
12G.O.	12*	1	17	16	1 1/4	17 3/4	14	19 3/4	19	20 1/2	-	1 1/4	2	15	Splined	2 7/8	16 1/16	25 1/16	-	18	16	15/16	54.7	48	519	736											
14G.O.	12*	1 1/8	18 3/4	20	1 1/4	20 1/4	15	30	21	23	-	1 3/8	2 1/8	16 1/4	Splined	1 11/16	16 9/16	25 9/16	-	18	16	15/16	57.8	37	599	916											
16G.O.	16	1 1/8	21 1/4	20	1 3/8	22 1/2	30	33	23 1/2	25 1/2	-	1 7/16	2 1/4	18 1/2	Splined	3 31/32	28 1/8	40 1/8	40 1/8	24	18 1/16	3 5/16	121.0	69	1865	2097											
18G.O.	16	1 1/4	22 3/4	24	1 3/8	24 3/4	34	36	25	28	-	1 9/16	2 3/8	21	Splined	3 31/32	28 1/8	40 1/8	40 1/8	24	18 1/16	3 5/16	121.0	54	1951	2183											

Dimensions for Class 150 and 300 valves are the same except where indicated. Flanges are to ANSI B16.5 and can meet flange draft requirements. W.O. is wrench operated. G.O. is gear operated.  
 \*The top two holes on each flange on the 8 in (200 mm), 10 in (250 mm), 12 in (300 mm) and 14 in (350 mm) G411 valves are drilled for studs. \*\*Weight includes wrench or operator.

**Metric Units**

Valve Size	Drilling Class 150			Drilling Class 300			A		B		C	E		F	G	H	J	K	M		N	W	X	Area of Port Sq Cm	Wt. In Kgs.**						
	No.	Size	BC	No.	Size	BC	Class		Class			Class							150	300						150	300	150	300	150	300
							150	300	150	300		150	300																		
15	4	15	60	4	15	67	108	140	89	98	81	11	14	35	13.5	11.1	18.3	-	121	121	-	152	-	1.59	2.9	3.5					
20	4	15	70	4	19	83	117	152	102	121	81	11	16	43	13.5	11.1	18.3	-	121	121	-	152	-	1.59	3.2	4.5					
25	4	16	79	4	19	89	127	165	108	124	94	11	17	51	19.8	16.7	22.2	-	122	122	-	178	-	5.1	4.8	7.8					
40	4	16	98	4	22	114	165	190	127	156	106	14	22	73	19.8	16.7	23.8	-	140	140	-	229	-	7.8	7.0	11.7					
50	4	19	121	8	19	127	178	216	152	165	121	16	22	92	27.0	22.2	25.4	-	160	160	-	305	-	13.0	10.6	13.3					
65	4	19	140	8	22	149	190	241	178	190	152	17	25	105	27.0	22.2	30.2	-	190	-	-	457	-	30.0	17.1	-					
80	4	19	152	8	22	168	203	283	190	210	152	19	29	127	27.0	22.2	30.2	-	190	190	-	457	-	30.0	18.4	31.0					
100	8	19	190	8	22	200	229	305	229	254	194	24	32	157	42.9	36.1	39.7	-	229	229	-	762	-	48.0	33.8	64.7					
100	8	19	190	8	22	200	229	305	229	254	-	24	32	157	42.9	36.1	39.7	213.0	495.0	495	305	224	76	48.0	42.5	73.7					
150	8	19	241	12	22	270	267	403	279	318	-	25	37	216	47.6	36.1	41.3	263.0	546.0	546	305	224	76	104.0	67.9	104.1					
200	8*	19	298	12	25	330	292	419	343	381	-	29	41.3	270	Splined	43.7	333.5	563.4	-	457	406	8	170.0	119.0	148.8						
250	12	25	362	16	29	387	330	457	406	445	-	30	47.6	324	Splined	69.0	388.9	614.5	-	457	406	33	264.0	180.0	206.4						
300	12	29	432	16	32	450	356	502	483	521	-	32	50.8	381	Splined	73.3	407.9	636.5	-	457	406	33	353.0	235.0	333.9						
350	12*	29	476	20	32	514	381	762	533	584	-	35	54	413	Splined	42.9	421.0	649.0	649	457	406	33	373.0	269.5	412.2						
405	16	29	540	20	35	572	762	838	597	648	-	37	57	470	Splined	101	714.0	1019.0	1019	610	459	84	781.0	846.0	951.2						
455	16	32	578	24	35	629	864	914	635	714	-	40	60	533	Splined	101	714.0	1019.0	1019	610	459	84	781.0	885.0	990.2						

# TSG4 Sleeve Valve Dimensions

1/2 in (15 mm) thru 3 in (75 mm)

G411 – Class 150

G431 – Class 300

1/2 in (15 mm) - 3 in (75 mm) Offset Wrench Standard

High Hub Wrench Optional

All dimensions are approximate and for illustration purposes only.  
For exact dimensions request certified dimensional prints.  
See page 19 for (L) dimensions.

## Stem Configuration

1/2 in (15 mm) to  
6 in (150 mm) flats

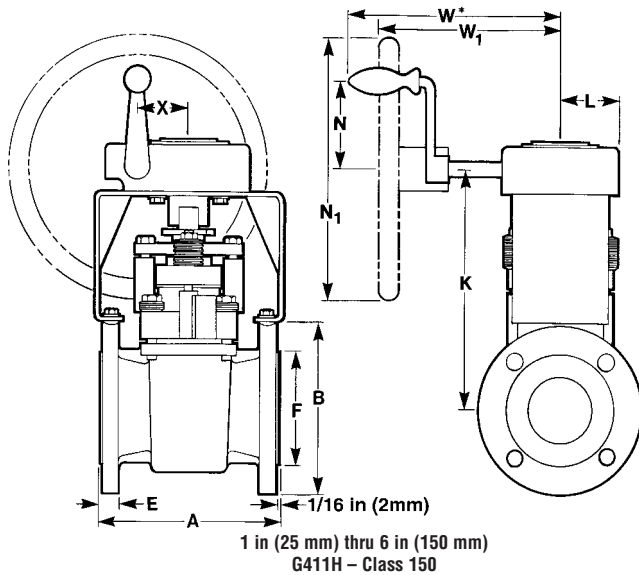
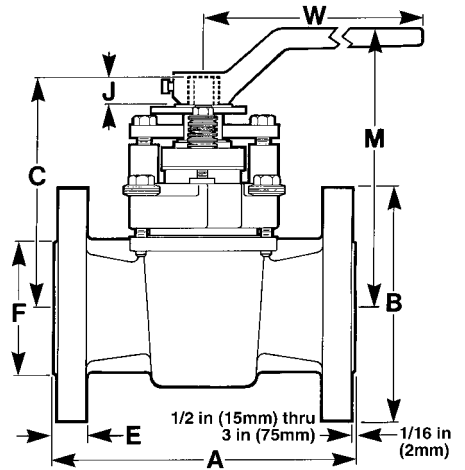
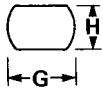

1 in (25 mm) thru 6 in (150 mm)  
G411H – Class 150

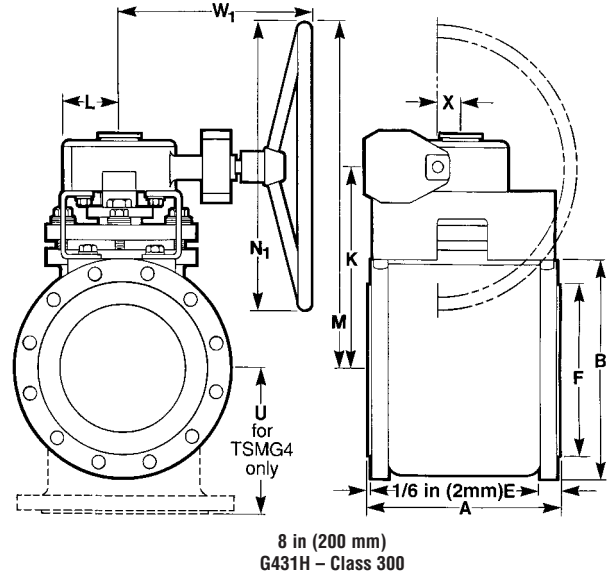

8 in (200 mm)  
G431H – Class 300

## English Units

Valve Size	Drilling Class 150			Drilling Class 300			A		B		C		E		F	G	H	J	K	L	M	N	N1	U		Area of Port Sq In	% Port Open	Weight Class						
	No.	Size	BC	No.	Size	BC	Class 150	Class 300	Class 150	Class 300	Class 150	Class 300	Class 150	Class 300	W	W*	W1	X	Class 150	Class 300	W	W*	W1	X	Class 150			Class 300						
1/2	4	5/8	23/8	4	5/8	25/8	4 1/4	5 1/2	3 1/2	3 7/8	6 11/32	7/16	9/16	13/8	17/32	7/16	5/8	-	-	7 1/2	-	-	-	23/4	27/8	7	-	-	-	.248	126	12.0	13.75	
3/4	4	5/8	23/4	4	3/4	3 1/4	4 5/8	6	3 7/8	4 3/4	6 11/32	7/16	5/8	1 11/16	17/32	7/16	5/8	-	-	7 1/2	-	-	-	27/8	3	7	-	-	-	.248	56	13.0	15.8	
1	4	5/8	3 1/8	4	3/4	3 1/2	5	6 1/2	4 1/4	4 7/8	6 15/16	7/16	1 1/16	2	25/32	2 1/32	1 1/16	8 11/16	2 13/32	8	4 9/16	-	-	3 1/2	3 3/4	9	8 13/16	-	127/32	.785	100	27.9	32.2	
1 1/2	4	5/8	3 7/8	4	7/8	4 1/2	6 1/2	7 1/2	5	6 1/8	7 1/4	9/16	13/16	2 7/8	25/32	2 1/32	3/4	9	2 13/32	8 5/16	4 9/16	-	-	4 1/8	4 3/8	9	8 13/16	-	127/32	1.21	68	33.1	39.1	
2	4	3/4	4 3/4	8	3/4	5	7	8 1/2	6	6 1/2	7 5/8	5/8	7/8	3 5/8	1 1/16	7/8	13/16	9 1/2	2 13/32	9 5/16	4 9/16	-	-	4 1/2	4 3/4	12	8 13/16	-	127/32	2.0	64	42.8	47.5	
3	4	3/4	6	8	7/8	6 5/8	8	11 1/8	7 1/2	8 1/4	8 31/32	3/4	1 1/8	5	1 1/16	7/8	1	10 7/8	2 11/16	10 1/2	4 9/16	-	-	5 1/8	5 9/16	20	9 13/16	-	2 3/8	4.6	65	69.6	83.2	
4G.O.	8	3/4	7 1/2	8	7/8	7 7/8	9	12	9	10	10 27/32	15/16	1 1/4	6 3/16	1 11/16	1 127/64	13/8	1 19/16	3 7/16	1 19/16	-	-	-	12	6	6 3/4	-	-	8 13/16	3	7.4	59	119.1	145.6
6G.O.	8	7/8	9 1/2	12	7/8	10 5/8	10 1/2	15 7/8	11	12 1/2	12 11/16	1	1 17/16	8 1/2	1 17/8	1 127/64	1 17/16	1 153/8	3 1/2	2 11/2	-	-	-	14	7 1/2	8 1/2	-	-	9 5/8	3 3/8	16.1	57	206.8	268.9
8G.O.	8	7/8	11 3/4	12	1	13	11 1/2	16 1/2	13 1/2	15	17 5/32	1 1/8	1 5/8	10 5/8	Splined	1 23/32	1 17/4	4	26 1/4	-	-	-	-	18	9	10	-	-	15 15/16	5/16	26.4	52	262.0	328.0

## Metric Units

Valve Size	Drilling Class 150			Drilling Class 300			A		B		C		E		F	G	H	J	K	L	M	N	N1	U		Area of Port Sq In	% Port Open	Weight Class						
	No.	Size	BC	No.	Size	BC	Class 150	Class 300	Class 150	Class 300	Class 150	Class 300	Class 150	Class 300	W	W*	W1	X	Class 150	Class 300	W	W*	W1	X	Class 150			Class 300						
15	4	16	60	4	16	67	108	140	89	98	161.1	11	14	35	13.5	11.1	15.8	-	-	190.5	-	-	-	70	73	178	-	-	-	1.59	126	5.4	6.2	
20	4	16	70	4	19	83	117	152	98	121	161.1	11	16	43	13.5	11.1	15.8	-	-	190.5	-	-	-	73	80	178	-	-	-	1.59	56	5.9	7.2	
25	4	16	79	4	19	89	127	165	108	124	176.2	11	17	51	19.8	16.7	17	220.6	61.1	203.2	116	-	-	89	95	229	223.8	-	47	5.1	100	12.6	14.6	
40	4	16	98	4	22.2	114	165	190	127	156	184.1	14	21	73	19.8	16.7	19	228.6	61.1	211.1	116	-	-	105	111	229	223.8	-	47	7.8	68	15.0	17.7	
50	4	19	121	8	19	127	178	216	152	165	193.6	16	22.2	92	27.0	22.2	22	241.3	61.1	236.5	116	-	-	108	121	309.8	223.8	-	47	13.0	64	19.4	21.5	
80	4	19	152	8	22.2	168	203	283	190	210	227.8	19	29	127	27.0	22.2	25	276.2	68.2	267	116	-	-	130	141	508	249	-	60	30.0	65	31.6	37.7	
100	8	19	190	8	22.2	200	229	305	229	254	275.4	24	32	157	42.9	36.1	34.9	293.6	87.3	495	-	-	304.8	150	171	-	-	-	223.8	76	48.0	59	54.0	66.0
150	8	22.2	241	12	22.2	270	267	403	279	318	322.2	25	37	216	47.6	36.1	36.5	390.5	88.9	546	-	-	355.6	190	216	-	-	-	244.5	85.7	104.0	57	93.8	121.9
200	8	22.2	298	12	25	330	292	419	343	381	435.7	29	41.3	270	Splined	43.7	438.1	101.6	666.7	-	-	-	457	229	250	-	-	-	404.8	8	170.0	52	118.8	148.8

# G4 & G4B 3-Way Valve Dimensions

English Units												
Valve Size	A Class		B Class		C	D Class		E Class		F	M	W
	150	300	150	300		150	300	150	300			
1/2	4 1/4	5 1/2	3 5/8	3 7/8	3 3/16	2 3/4	2 7/8	7/16	9/16	1 3/8	4 25/32	6
3/4	4 5/8	6	4	4 3/4	3 3/16	3	3	7/16	9/8	1 11/16	4 25/32	6
1	5	6 1/2	4 1/4	4 7/8	3 23/32	3 1/2	3 3/4	7/16	1 1/16	2	4 13/16	7
1 1/2	6 1/2	7 1/2	5	6 1/8	4 5/32	4 1/8	4 3/8	9/16	1 3/16	2 7/8	5 1/2	9
2	7	8 1/2	6	6 1/2	4 3/4	4 1/2	4 3/4	5/8	7/8	3 5/8	6 5/16	12
3	8	11 1/2	7 1/2	8 1/4	6	5 1/8	5 9/16	3/4	1 1/8	5	7 1/2	18
4	9	12	9	10	7 21/32	6	6 3/4	15/16	1 1/4	6 3/16	18 3/8	30
6	10 1/2	15 7/8	11	12 1/2	-	7 1/2	8 1/2	1	1 7/16	8 1/2	-	-
8	11 1/2	16 1/2	13 1/2	15	-	9	10	1 1/8	1 5/8	10 5/8	-	-
10	13	18	16	17 1/2	-	12 1/4	12 1/4	1 3/16	1 7/8	12 3/4	-	-

Metric Units												
Valve Size	A Class		B Class		C	D Class		E Class		F	M	W
	150	300	150	300		150	300	150	300			
15	108	140	92	98	81	76	76	11	14	32	121	152
20	117	152	102	121	81	76	76	11	16	43	121	152
25	127	165	108	124	94	89	95	11	17	51	122	178
40	165	190	127	156	106	105	111	14	21	73	140	229
50	178	216	152	165	121	114	121	16	22	92	160	305
80	203	283	190	210	152	130	141	19	29	127	190	457
100	229	305	229	254	194	152	171	24	32	157	229	762
150	267	403	289	318	-	190	216	25	37	216	-	-
200	292	419	343	381	-	229	254	29	41	270	-	-
250	330	457	406	444	-	311	311	30	48	324	-	-

Dimensions of gears and gear mountings are the same as for straightway valves, with the exception of 8 in (200 mm), 180° 3-way valves. For stem dimensions consult factory.  
All dimensions are approximate and for illustration purposes only. For exact dimensions request certified dimensional prints.

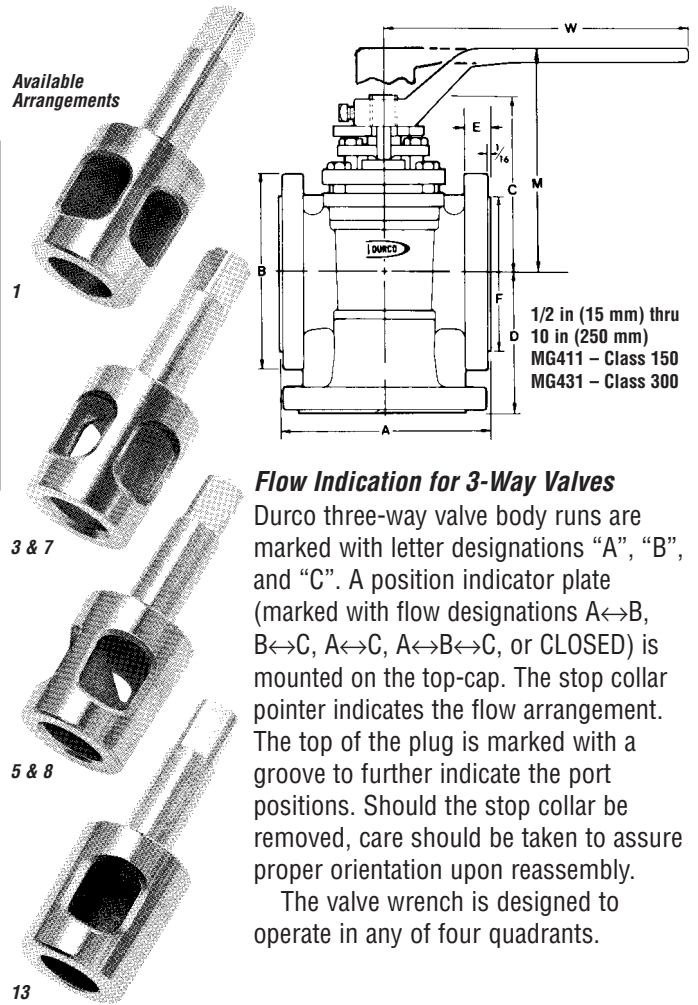

**Flow Indication for 3-Way Valves**  
Durco three-way valve body runs are marked with letter designations "A", "B", and "C". A position indicator plate (marked with flow designations A↔B, B↔C, A↔C, A↔B↔C, or CLOSED) is mounted on the top-cap. The stop collar pointer indicates the flow arrangement. The top of the plug is marked with a groove to further indicate the port positions. Should the stop collar be removed, care should be taken to assure proper orientation upon reassembly.  
The valve wrench is designed to operate in any of four quadrants.

## Flow Arrangements

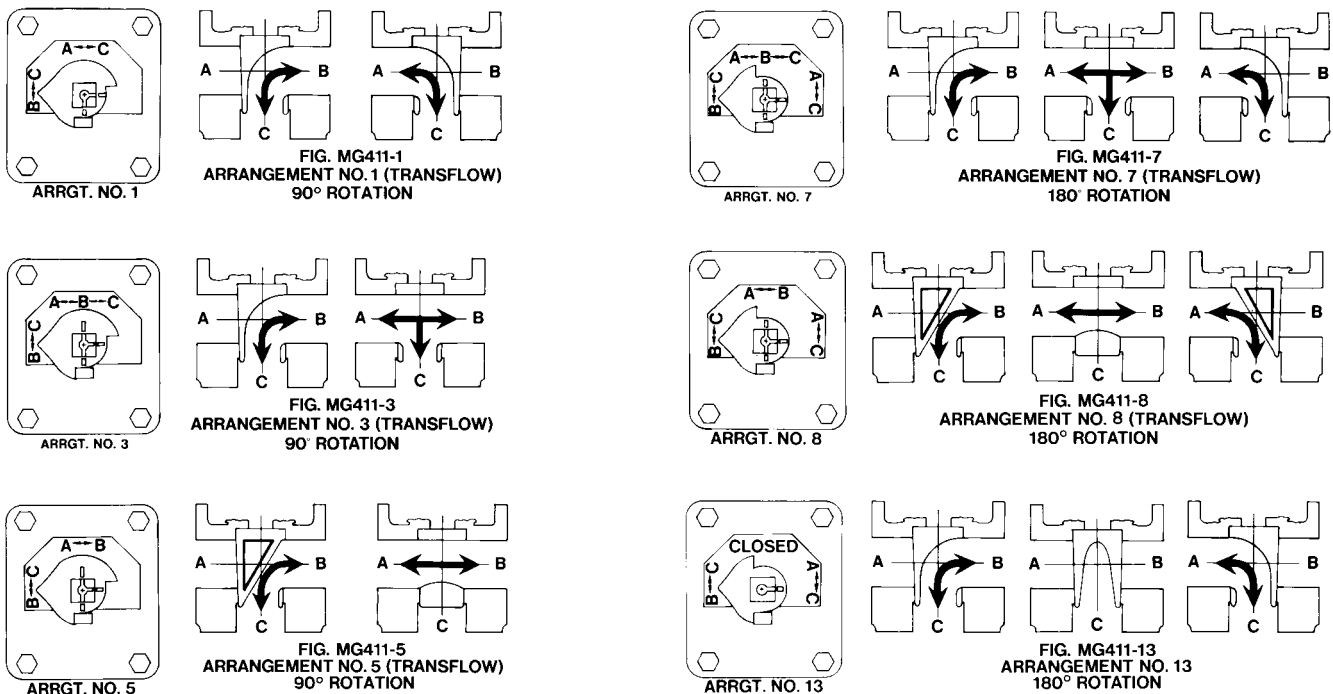



# G4 & G4B Jacketed Valve Dimensions

## Partially Jacketed Valves\*

1 in (25 mm) thru 12 in (300 mm)

PJG411 – Class 150

PJG431 – Class 300

All dimensions are approximate and for illustration purposes only. For exact dimensions request certified dimensional prints.

\*For remainder of valve dimensions, refer to straightway valve dimensions, page 12. The 4 in (100 mm) and larger sizes are gear operated.

English Units			
Valve Size	X	Y	No. of Conn.
1	1/2	2 <sup>15</sup> / <sub>16</sub>	3
1 1/2	9/16	2 <sup>3</sup> / <sub>4</sub>	3
2	3/4	2 <sup>15</sup> / <sub>16</sub>	3
3	1 1/4	3 <sup>1</sup> / <sub>4</sub>	3
4	2 1/4	3 <sup>3</sup> / <sub>4</sub>	3
6	3	4 1/4	3
8	4 1/2	5 <sup>3</sup> / <sub>4</sub>	3
10	6	6 <sup>3</sup> / <sub>4</sub>	3

Metric Units		
Valve Size	X	Y
25	13	75
40	14	70
50	19	75
80	31	82
100	57	95
150	76	108
200	208	146
250	152	171

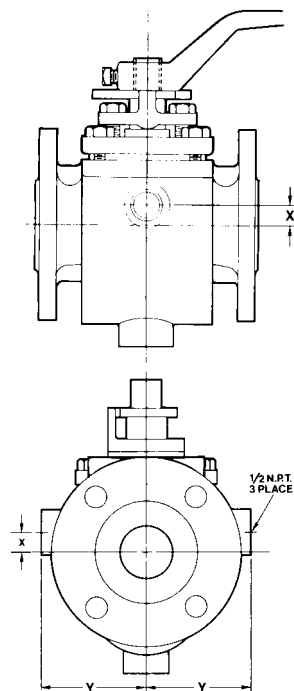

## Fully Jacketed Valves\*

1 in (25 mm) thru 6 in (150 mm)

FJG411 – Class 150

FJG431 – Class 300

All valves furnished with 1/16 in (2 mm) R.F. flanges to ASME (ASA) B 16.5 Std.

The jacket is designed for 150 psi saturated steam.

Jackets are same material as body.

\*Gear operated—for additional dimensions call factory.

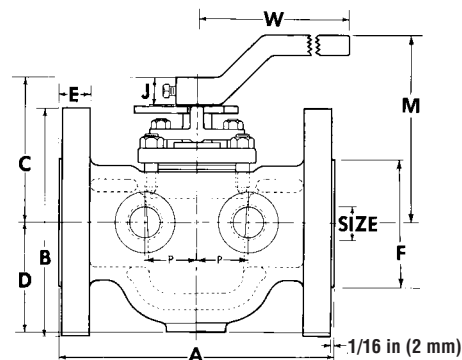

### Stem Configuration

1/2 in (15 mm) to 6 in (150 mm) flats



English Units																										
Valve Size	Nom. Flange Size	Drilling Class 150			Drilling Class 300			A		B		C	D	E		F	G	H	J	M	P	W	No. of Conn.	Jkt. Conn. NPT	Wt. in Lbs.	
		No.	Size	BC	No.	Size	BC	150	300	150	300			150	300										150	300
1	2	4	3/4	4 <sup>3</sup> / <sub>4</sub>	8	3/4	5	7	7 <sup>5</sup> / <sub>8</sub>	6	6 <sup>1</sup> / <sub>2</sub>	3 <sup>23</sup> / <sub>32</sub>	2 <sup>3</sup> / <sub>4</sub>	9/16	7/8	3 <sup>5</sup> / <sub>8</sub>	2 <sup>5</sup> / <sub>32</sub>	2 <sup>1</sup> / <sub>32</sub>	7/8	4 <sup>13</sup> / <sub>16</sub>	1 <sup>5</sup> / <sub>16</sub>	7	5	3/4	28	48
1 1/2	2 1/2	4	3/4	5 1/2	8	7/8	5 <sup>7</sup> / <sub>8</sub>	7 1/2	8 1/4	7	7 1/2	4 <sup>5</sup> / <sub>32</sub>	3	5/8	1	4 <sup>1</sup> / <sub>8</sub>	2 <sup>5</sup> / <sub>32</sub>	2 <sup>1</sup> / <sub>32</sub>	1 <sup>5</sup> / <sub>16</sub>	5 1/2	1 <sup>3</sup> / <sub>8</sub>	9	5	3/4	41	67
2	3	4	3/4	6	8	7/8	6 <sup>5</sup> / <sub>8</sub>	8	8 <sup>7</sup> / <sub>8</sub>	7 1/2	8 1/4	4 <sup>3</sup> / <sub>4</sub>	3 1/2	1 <sup>1</sup> / <sub>16</sub>	1 1/8	5	1 <sup>1</sup> / <sub>16</sub>	7/8	1	6 <sup>5</sup> / <sub>16</sub>	1 <sup>3</sup> / <sub>8</sub>	12	5	1	50	71
3	4	8	3/4	7 1/2	8	7/8	7 <sup>7</sup> / <sub>8</sub>	9	9 <sup>3</sup> / <sub>4</sub>	9	10	6	4 1/4	7/8	1 1/4	6 <sup>3</sup> / <sub>16</sub>	1 <sup>1</sup> / <sub>16</sub>	7/8	1 <sup>3</sup> / <sub>16</sub>	7 1/2	1 <sup>3</sup> / <sub>4</sub>	18	5	1	84	131
4	6	8	7/8	9 1/2	12	7/8	10 <sup>5</sup> / <sub>8</sub>	10 1/2	11 1/2	11	12 1/2	7 <sup>21</sup> / <sub>32</sub>	5 <sup>3</sup> / <sub>16</sub>	1 <sup>5</sup> / <sub>16</sub>	1 <sup>7</sup> / <sub>16</sub>	8 1/2	1 <sup>11</sup> / <sub>16</sub>	1 <sup>27</sup> / <sub>64</sub>	1 <sup>9</sup> / <sub>16</sub>	9 1/2	2	30	5	1 1/4	175	291
6	8	8	7/8	11 <sup>3</sup> / <sub>4</sub>	12	1	13	11 1/2	12 <sup>5</sup> / <sub>8</sub>	13 1/2	15	*	6 <sup>7</sup> / <sub>16</sub>	1 <sup>1</sup> / <sub>16</sub>	1 <sup>5</sup> / <sub>8</sub>	10 <sup>5</sup> / <sub>8</sub>	1 <sup>7</sup> / <sub>8</sub>	1 <sup>27</sup> / <sub>64</sub>	1 <sup>9</sup> / <sub>16</sub>	*	2 1/2	*	5	1 1/4	302	437

Metric Units																								
Valve Size	Nom. Flange Size	Drilling Class 150			Drilling Class 300			A		B		C	D	E		F	G	H	J	M	P	W	Wt. in Kgs.	
		No.	Size	BC	No.	Size	BC	150	300	150	300			150	300								150	300
25	50	4	19	121	8	19	127	178	194	154	165	94	70	14	22	92	20	17	22	122	33	178	12.6	21.6
40	65	4	19	140	8	22	149	190	210	178	190	106	76	16	25	105	20	17	24	140	35	229	18.4	30.2
50	80	4	19	152	8	22	168	203	255	190	210	121	89	17	29	127	27	22	25	160	35	305	22.5	32.0
80	100	8	19	190	8	22	200	229	248	229	254	273	108	19	32	157	27	22	30	190	44	457	37.8	59.0
100	150	8	22	241	12	22	270	267	292	279	318	194	132	24	37	216	43	36	40	229	50	762	78.8	131.0
150	200	8	22	298	12	25	330	292	321	343	381	*	164	27	41	270	48	36	40	*	64	*	135.9	196.7

# G4 & G4B Screwed End Valve Dimensions

## Straightway Screwed End Valves

1/4 in (5 mm) thru 2 in (50 mm)  
G432 Class 150 & 300  
1/4 in (5 mm) - 3/4 in (20 mm)  
High Hub Wrench Standard

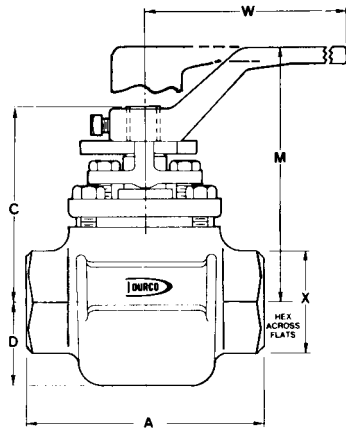

### English Units

Valve Size	A	C	D	M	W	X	Area of Port Sq. In.	% Port Opening Based on Nominal Size	Wt. in Lbs.
1/4	3 1/2	33/16	111/32	425/32	6	19/16	.248	506	4
3/8	3 1/2	33/16	111/32	425/32	6	19/16	.248	225	3 3/4
1/2	3 1/2	33/16	111/32	425/32	6	19/16	.248	126	3 3/4
3/4	3 1/2	33/16	111/32	425/32	6	19/16	.248	56	3 1/2
1	4 5/8	323/32	119/32	413/16	7	115/16	.785	100	7
1 1/2	5 1/2	45/32	17/8	5 1/2	9	29/16	1.21	68	9 1/4
2	6	43/4	27/32	65/16	12	3 1/8	2.0	64	15 3/4

### Metric Units

Valve Size	A	C	D	M	W	X	Area of Port Sq. Cm.	Wt. in Kgs.
5	89	81	34	121	152	40	1.59	1.8
10	89	81	34	121	152	40	1.59	1.7
15	89	81	34	121	152	40	1.59	1.7
20	89	81	34	121	152	40	1.59	1.6
25	117	94	40	122	178	49	5.1	3.2
40	140	106	48	140	229	65	7.8	4.2
50	152	121	56	160	305	79	13.0	7.1

## 3-Way Screwed End Valves

1/2 in (15 mm) thru 2 in (50 mm)  
MG432 Class 150 & 300  
1/4 in (5 mm) - 3/4 in (20 mm)  
High Hub Wrench Standard

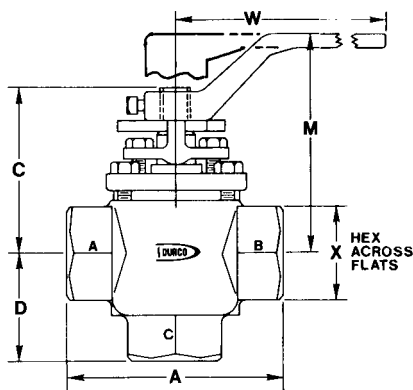

### English Units

Valve Size	A	C	D	Wrench Sq. Dim.	M	W	X	Wt. in Lbs.
1/4	3 1/2	33/16	13/4	7/16	425/32	6	19/16	43/4
3/8	3 1/2	33/16	13/4	7/16	425/32	6	19/16	41/2
1/2	3 1/2	33/16	1 11/16	7/16	425/32	6	19/16	41/2
3/4	3 1/2	33/16	13/4	7/16	425/32	6	19/16	41/4
1	4 5/8	223/32	23/8	21/32	413/16	7	115/16	10 1/2
1 1/2	5 1/2	45/32	27/8	21/32	5 1/2	9	29/16	17 1/2
2	6	43/4	33/8	7/8	65/16	12	3 1/8	22 1/2

### Metric Units

Valve Size	A	C	D	Wrench Sq. Dim.	M	W	X	Wt. in Kgs.
5	89	81	44	11	121	152	40	2.2
10	89	81	44	11	121	152	40	2
15	89	81	44	14	121	152	40	2
20	89	81	44	14	121	152	40	1.9
25	117	69	60	14	122	178	49	4.7
40	140	106	73	14	140	229	65	7.9
50	152	121	86	22	160	305	79	10.1

All dimensions are approximate and for illustration purposes only.  
For exact dimensions request certified dimensional prints.

# G4 & G4B Weld End Valve Dimensions

## Socket Weld Valves ASME B16.11

These valves can be welded without disassembly of the valve. Consult IOM-240, available from Flowserve Corporation, for welding procedures and precautions. Welding of ductile iron is not recommended.

1/4 in (5 mm) thru 2 in (50 mm)  
G434 Class 150 & 300  
1/4 in (5 mm) - 3/4 in (20 mm)  
High Hub Wrench Standard

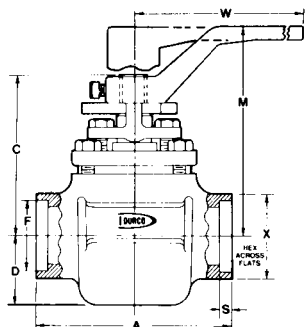

## English Units

Valve Size	A	C	D	F	M	S	W	X	Area of Port Sq. In.	% Port Opening Based on Nominal Size	Wt. in Lbs.
1/4	3 1/2	3 3/16	1 11/32	—	4 25/32	—	6	1 9/16	.248	506	2
3/8	3 1/2	3 3/16	1 11/32	—	4 25/32	—	6	1 9/16	.248	225	2
1/2	3 1/2	3 3/16	1 11/32	.86	4 25/32	3/8	6	1 9/16	.248	126	2
3/4	3 1/2	3 3/16	1 11/32	1.07	4 25/32	1/2	6	1 9/16	.248	56	2 3/4
1	4 5/8	3 23/32	1 19/32	1.33	4 13/16	1/2	7	1 15/16	.785	100	7
1 1/2	5 1/2	4 5/32	1 7/8	1.91	5 1/2	1/2	9	2 9/16	1.21	68	9 1/4
2	6	4 3/4	2 7/32	2.40	6 5/16	5/8	12	3 1/8	2.0	64	15 3/4

## Metric Units

Valve Size	A	C	D	F	M	S	W	X	Area of Port Sq. Cm.	Wt. in Kgs.
5	89	81	34	—	121	—	152	40	1.597	0.9
10	89	81	34	—	121	—	152	40	1.597	0.9
15	89	81	34	22.0	121	10	152	40	1.597	0.9
20	89	81	34	27.0	121	13	152	40	1.59	1.2
25	117	94	40	33.8	122	13	178	49	5.1	3.2
40	140	106	48	48.5	140	13	229	65	7.8	4.2
50	152	121	56	61.0	160	16	305	79	13.0	7.1

**Note:** Not available in ductile cast iron. Valves provided in D20, DC2, DC3, and DM will be furnished with stub ends pre-welded into valve.

## Butt Weld Valves

These valves can be welded without disassembly of the valve. Consult IOM-240, available from Flowserve Corporation, for welding procedures and precautions. Welding of ductile iron is not recommended. 4 in (100 mm) through 12 in (300 mm) valves are normally gear operated. Butt-weld valves are machined to match schedule 40 (ASME) piping systems unless otherwise specified.

1/2 in (15 mm) thru 12 in (300 mm)  
G413 Class 150  
G433 Class 300

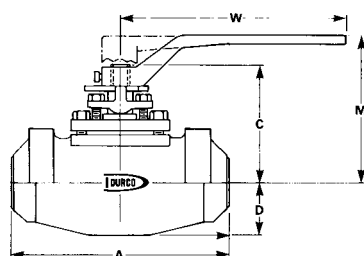

All dimensions are approximate and for illustration purposes only. For exact dimensions request certified dimensional prints.

## English Units

Valve Size	A 150	A 300	C	D	M	W	Area of Port Sq. In.	% Port Opening Based on Nominal Size
1/2	6 1/2	6 1/2	3 3/16	1 7/32	4 25/32	6	.248	126
3/4	6 1/2	6 1/2	3 3/16	1 7/32	4 25/32	6	.248	56
1	6 1/2	6 1/2	3 23/32	1 19/32	4 13/16	7	.785	100
1 1/2	7 1/2	7 1/2	4 5/32	1 7/8	5 1/2	9	1.21	68
2	8 1/2	8 1/2	4 3/4	2 7/32	6 5/16	12	2.0	64
3	12	12	6	2 29/32	7 1/2	18	4.6	65
4	14	14	7 21/32	3 11/16	10 9/32	30	7.4	59
6	17	17	9 23/32	4 7/8	—	—	16.1	57
8	20	20	•	6 7/16	—	—	27.7	55
12	26	26	*	9 3/16	—	—	57.8	37

## Metric Units

Valve Size	A 150	A 300	C	D	M	W	Area of Port Sq. Cm.
15	165	165	81	31	127	152	1.59
20	165	165	81	31	127	152	1.59
25	165	165	94	40	122	178	5.1
40	191	191	106	48	140	229	7.8
50	216	216	121	56	160	305	13.0
80	305	305	152	74	191	457	30.0
100	356	356	194	94	261	762	48.0
150	432	432	247	124	314	1168	104
200	508	508	*	163	—	—	179
300	660	660	*	233	—	—	373

**Note:** Not available in ductile cast iron. Valves provided in D20, DC2, DC3, and DM will be furnished with stub ends pre-welded into valve.



# Manual Actuator & Trim Options

## Handwheel Extension

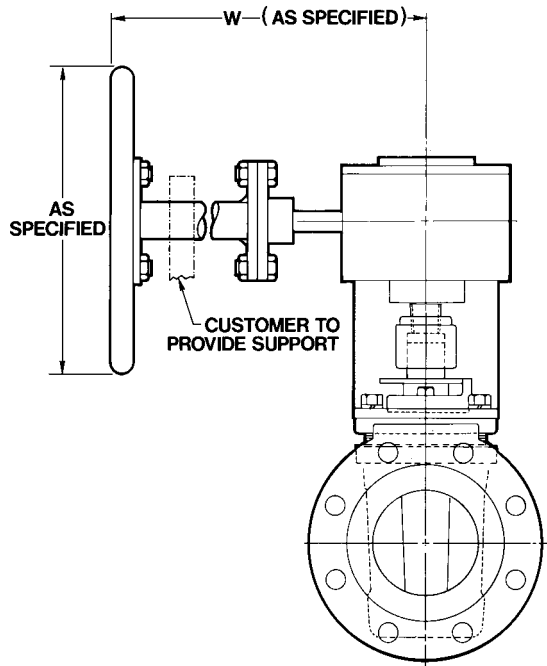

## T-Handle Wrench

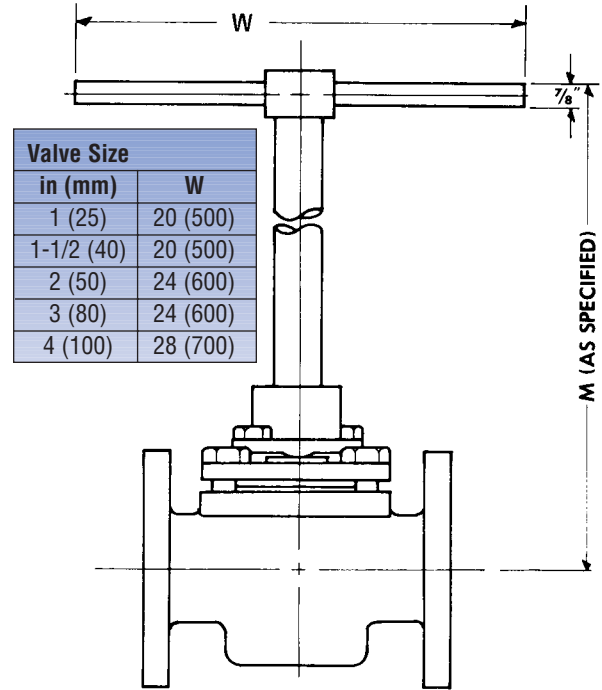

## Chlorine Valve

The Durco G4 Chlorine Valve is built in accordance with the recommendations of The Chlorine Institute. This valve is manufactured with a cast carbon steel body and a vented Monel plug for dry chlorine service. It is cleaned, dried and packaged for delivery.

Vented plug design is also recommended for other cold liquids such as anhydrous HCL.

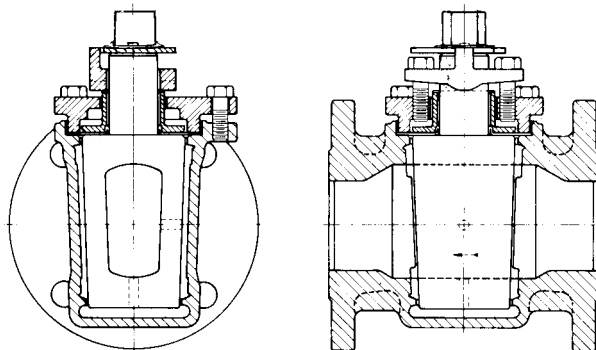

## Double Block and Bleed

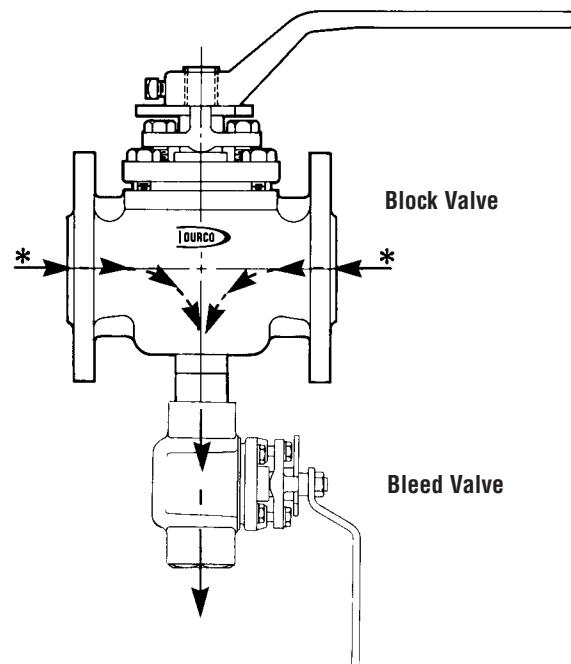

\* Plug cavity and upstream or downstream bleed capability as specified by the customer. 1/4 in (5 mm) bleed valve is standard—other sizes are available.

## Double End Chain Wrench

Note: Customer must specify horizontal or vertical installation.

1 in (25 mm) thru  
3 in (75 mm)

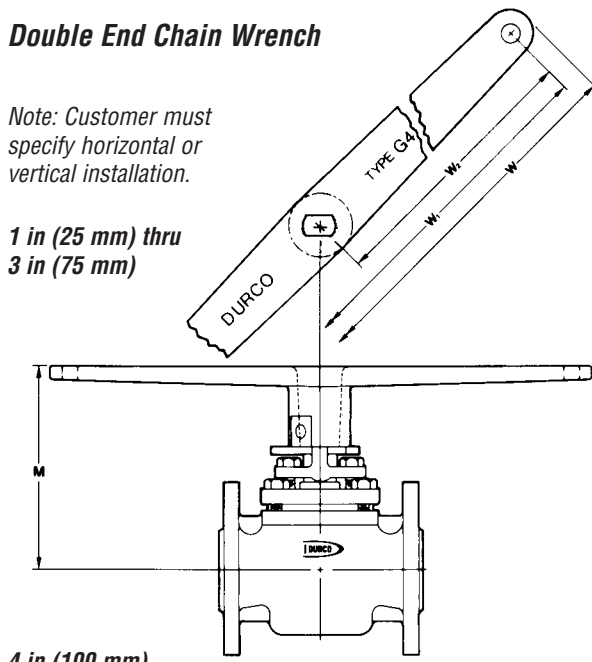

4 in (100 mm)

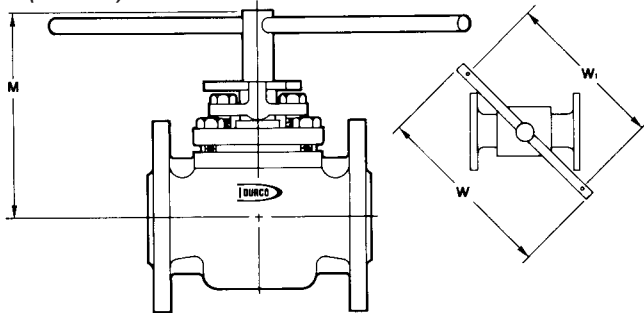

## Crank

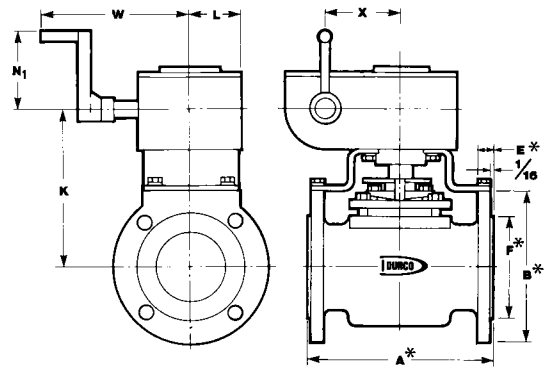

## Chain Wheel

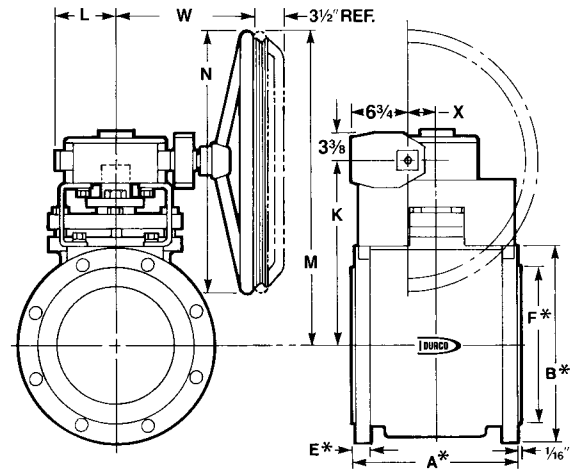

### English Units

Valve Size	M	W	W <sub>1</sub>	W <sub>2</sub>
1	3 <sup>23</sup> / <sub>32</sub>	13 <sup>1</sup> / <sub>2</sub>	12	6
1 1/4	5 <sup>21</sup> / <sub>32</sub>	13 <sup>1</sup> / <sub>2</sub>	12	6
1 1/2	5 <sup>21</sup> / <sub>32</sub>	13 <sup>1</sup> / <sub>2</sub>	12	6
2	5 <sup>1</sup> / <sub>4</sub>	25	24	12
2 1/2	6 <sup>5</sup> / <sub>16</sub>	25	24	12
3	6 <sup>5</sup> / <sub>16</sub>	25	24	12
4	9 <sup>1</sup> / <sub>2</sub>	62	60	-

### Metric Units

Valve Size	M	W	W <sub>1</sub>	W <sub>2</sub>
25	94	343	305	152
30	144	343	305	152
40	144	343	305	152
50	133	635	610	305
65	160	635	610	305
80	160	635	610	305
100	241	1575	1524	-

### English Units

Valve Size	K	L	M	N	N <sub>1</sub>	W	X	Sprocket Size
1	4 <sup>1</sup> / <sub>4</sub>	2 <sup>3</sup> / <sub>8</sub>	-	8	4 <sup>9</sup> / <sub>16</sub>	7 <sup>1</sup> / <sub>8</sub>	1 <sup>13</sup> / <sub>16</sub>	2
1 1/2	4 <sup>3</sup> / <sub>4</sub>	2 <sup>3</sup> / <sub>8</sub>	-	8	4 <sup>9</sup> / <sub>16</sub>	7 <sup>1</sup> / <sub>8</sub>	1 <sup>13</sup> / <sub>16</sub>	2
2	5 <sup>1</sup> / <sub>16</sub>	2 <sup>3</sup> / <sub>8</sub>	-	8	4 <sup>9</sup> / <sub>16</sub>	7 <sup>1</sup> / <sub>8</sub>	1 <sup>13</sup> / <sub>16</sub>	2
3	6 <sup>5</sup> / <sub>16</sub>	2 <sup>11</sup> / <sub>16</sub>	-	8	4 <sup>9</sup> / <sub>16</sub>	8 <sup>1</sup> / <sub>8</sub>	2 <sup>3</sup> / <sub>8</sub>	2
4	8 <sup>3</sup> / <sub>8</sub>	3 <sup>7</sup> / <sub>16</sub>	-	13	1 <sup>11</sup> / <sub>8</sub>	1 <sup>12</sup> / <sub>16</sub>	3	2 1/2
6	10 <sup>3</sup> / <sub>8</sub>	3 <sup>7</sup> / <sub>16</sub>	-	13	1 <sup>11</sup> / <sub>8</sub>	1 <sup>12</sup> / <sub>16</sub>	3	2 1/2
8	13 <sup>1</sup> / <sub>8</sub>	4	2 <sup>21</sup> / <sub>8</sub>	18	-	1 <sup>15</sup> / <sub>16</sub>	5 <sup>1</sup> / <sub>16</sub>	3 1/2
10	14 <sup>9</sup> / <sub>16</sub>	4 <sup>1</sup> / <sub>2</sub>	2 <sup>23</sup> / <sub>16</sub>	18	-	1 <sup>15</sup> / <sub>16</sub>	1 <sup>15</sup> / <sub>16</sub>	3 1/2
12	13 <sup>9</sup> / <sub>16</sub>	4 <sup>1</sup> / <sub>2</sub>	2 <sup>22</sup> / <sub>16</sub>	18	-	1 <sup>15</sup> / <sub>16</sub>	1 <sup>15</sup> / <sub>16</sub>	3 1/2
14	16 <sup>9</sup> / <sub>16</sub>	4 <sup>1</sup> / <sub>2</sub>	2 <sup>25</sup> / <sub>16</sub>	18	-	16	1 <sup>15</sup> / <sub>16</sub>	3 1/2
16	24 <sup>5</sup> / <sub>16</sub>	6	3 <sup>6</sup> / <sub>16</sub>	24	-	1 <sup>18</sup> / <sub>16</sub>	3 <sup>5</sup> / <sub>16</sub>	4 1/2
18	24 <sup>5</sup> / <sub>16</sub>	6	3 <sup>6</sup> / <sub>16</sub>	24	-	1 <sup>18</sup> / <sub>16</sub>	3 <sup>5</sup> / <sub>16</sub>	4 1/2

### Metric Units

Valve Size	K	L	M	N	N <sub>1</sub>	W	X	Sprocket Size
25	108	60	-	203	116	181	46	51
40	121	60	-	203	116	181	46	51
50	129	60	-	203	116	181	46	51
75	160	68	-	203	116	207	60	51
100	213	87	-	330	283	306	76	64
150	264	87	-	330	283	306	76	64
200	527	102	794	457	-	405	8	64
250	370	114	598	457	-	405	33	89
300	344	114	573	457	-	405	33	89
350	421	114	649	457	-	405	33	89
400	618	152	922	610	-	459	84	114
450	618	152	922	610	-	459	84	114

All dimensions are approximate and for illustration purposes only.  
For exact dimensions request certified dimensional prints.

# Parts and Materials

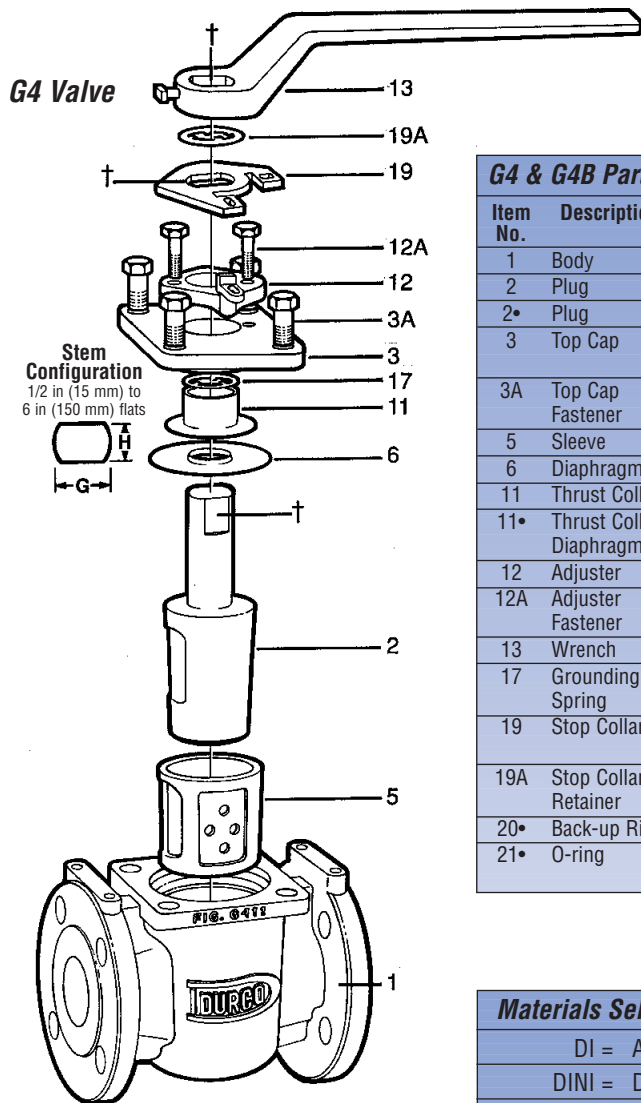

G4 & G4B Parts and Materials			
Item No.	Description	Material of Construction	No. Req.
1	Body	*	1
2	Plug	*	1
2•	Plug	*	1
3	Top Cap	Durcomet 100**/ Ductile Iron	1
3A	Top Cap Fastener	B8M3 SS/B7 (CR-MO) Steel	4
5	Sleeve	PTFE***	1
6	Diaphragm	PFA***	1
11	Thrust Collar	Durcomet 100	1
11•	Thrust Collar/ Diaphragm	Durcomet 100/ Hastelloy®	1
12	Adjuster	Durcomet 100	1
12A	Adjuster Fastener	B8-40 SS/B7 (CR-MO) Steel	2
13	Wrench	Ductile Iron	1
17	Grounding Spring	304 SS	1
19	Stop Collar	Zinc Plated Carbon Steel	1
19A	Stop Collar Retainer	302 SS	1
20•	Back-up Ring	PTFE	2
21•	O-ring	Viton (Kalrez optional)	2

## G4B Exclusive Parts

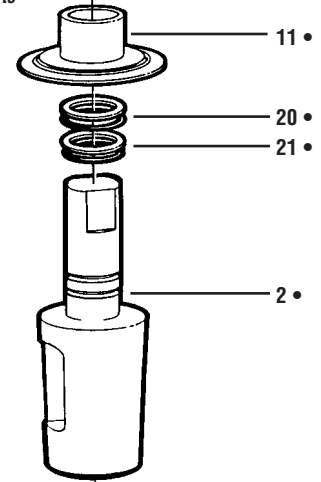

\* Body (Item No. 1) and Plug (Item No. 2) available in the following cast materials: Ductile Iron; Carbon Steel; CF-8 SS; Durcomet 100; Durimet 20; Chlorimet 2 and 3; Nickel; Monel; Inconel; Titanium and Zirconium.  
 \*\* Durcomet 100 is a high alloy stainless steel, CD4M Cu.  
 \*\*\* Other materials available on request.  
 • Parts exclusive to G4B.

Applicable Valve Standards	
Specification	Title
ASME B16.10	Face-to-face dimension
ASME B16.34	Steel valves, flanged & butt weld
ASME B16.5	Flange & flange fitting
ASME B1.20.1	Screwed ends
API 607	Fire safe valve testing
API 598	Valve inspection & test
ASME B16.11	Forged fittings, socket weld and threaded
M.S.S. SP-54	Radiographic
M.S.S. SP-55	Visual quality
M.S.S. SP-61	Hydrostatic testing

Materials Selection Chart A	
DI	ASTM A395 Ductile Cast Iron
DINI	Ductile Cast Iron Nickel Plated (Plug Only)
DS	ASTM A216 Gr. WCB (Cast Steel)
DSNI	Cast Steel Nickel Plated (Plug Only 3 in or larger)
D2	ASTM A351/A744 Gr. CF8 (304 S.S.)
D2L	ASTM A351/A744 Gr. CF3 (304L S.S.)
D4	ASTM A351/A744 Gr. CF8M (316 S.S.)
D4L	ASTM A351/A744 Gr. CF3M (316L S.S.)
DV	Durcomet 5 (Durco's High Silicon Stainless Steel)
CD	ASTM A351/A744 Gr. CD4M Cu (Durcomet 100)
D20	ASTM A351/A744 Gr. CN-7M (Durimet 20)
CK3M	ASTM A351/A744 Gr. CK-3MCuN (254 SMO) <sup>1</sup>
DIN	ASTM A494 Gr. CY-40 (Inconel 600) <sup>2</sup>
DM	ASTM A494 Gr. M35-2 (Monel 400) <sup>2</sup>
DM1	ASTM A494 Gr. M35-1 (Monel 400) <sup>2</sup>
DNI	ASTM A494 Gr. CZ-100 (Nickel 200)
DC2	ASTM A494 Gr. N-7M (Chlorimet 2)
DC3	STM A494 Gr. CW-6M (Chlorimet 3)
Ti	ASTM B367 Gr. C-3 (Titanium)
Zr	ASTM B752 Gr. 702C (Zirconium)
Zr5	ASTM B752 Gr. 705C (Zirconium)

1. Registered trademark of Avesta AB  
 2. Registered trademark of the International Nickel Company, Inc.



### G4Z

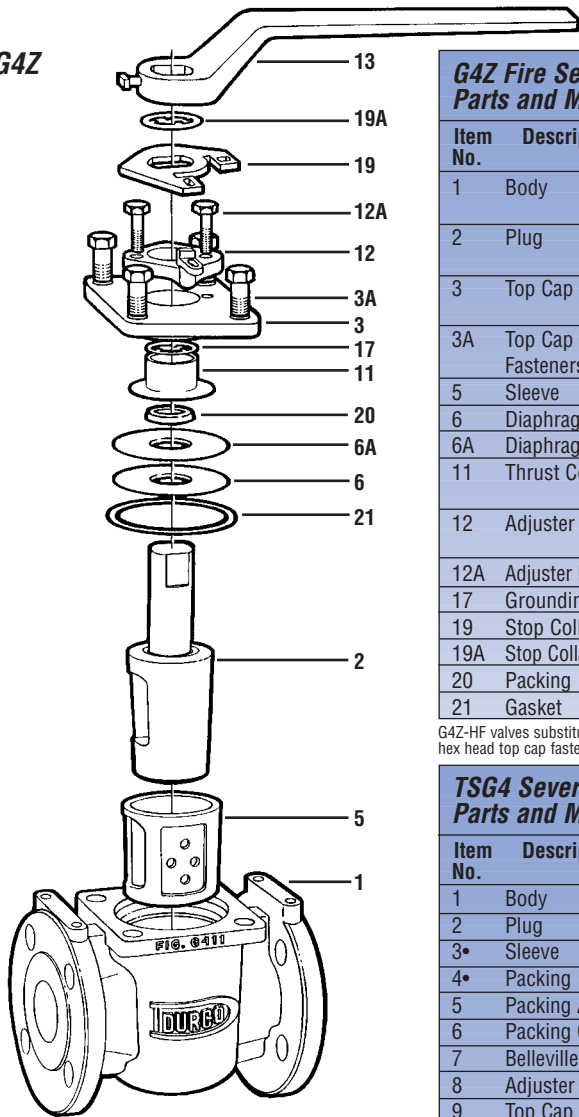

#### G4Z Fire Sealed Parts and Materials

Item No.	Description	Material of Construction
1	Body	ASTM A351 A744 Gr. CF8M
2	Plug	ASTM A351 A744 Gr. CF8M
3	Top Cap	ASTM A744 Gr. CD4MCu
3A	Top Cap Fasteners	B8M3 SS/B7 (CR-MO) Steel
5	Sleeve	PTFE
6	Diaphragm	PFA****
6A	Diaphragm	Steel or Monel
11	Thrust Collar	ASTM A744 Gr. CD4MCu
12	Adjuster	ASTM A744 Gr. CD4MCu
12A	Adjuster Fasteners	B7M
17	Grounding Spring	302 S.S.
19	Stop Collar	Zinc Plated Steel
19A	Stop Collar Retainer	302 SS
20	Packing	Grafoil®
21	Gasket	Grafoil®

G4Z-HF valves substitute B7M studs and 2M nuts for hex head top cap fasteners.

#### TSG4 Severe Service Parts and Materials

Item No.	Description	Material of Construction
1	Body	ALY*
2	Plug	ALY*
3•	Sleeve	TFE
4•	Packing	PTFE
5	Packing Adjuster	D100
6	Packing Gland	304SS
7	Belleville Washers	17-7 PH E.N.C.***
8	Adjuster Fasteners	B7/B8
9	Top Cap	ALY*
10	Top Cap Fasteners	B7/B8
11	Plug Adjuster	ASTMA 744 Gr. CD4MCu
12	Plug Adjuster Fasteners	B7/B8
13	Stop Collar	Zinc Plated Steel
14	Belleville Washers	17-7 PH E.N.C.***
15	Stop Collar Retainer	302SS
16•	Grounding Spring	302 SS
17	Plug Gland	304 SS
18•	Thrust Washer	Glass Filled TFE
19•	Plug Bearing	TFE
20•	Gasket - Top Cap	GY**

\* Carbon Steel; 316SS; Durimet 20; Chlorimet 3; Monel. Plug and Top Cap are typically the same alloy unless otherwise specified.

\*\* Part Nos. 4 & 20 are Grafoil® on Fire Sealed TSG4Z.

\*\*\* Part Nos. 7 & 14 are not normally used on Fire Sealed TSG4Z. Optional Inconel 718 recommended in corrosive environments.

\*\*\*\* Other materials available.

• Recommended spare parts.

© Grafoil is a registered trademark of Union Carbide.

### TSG4

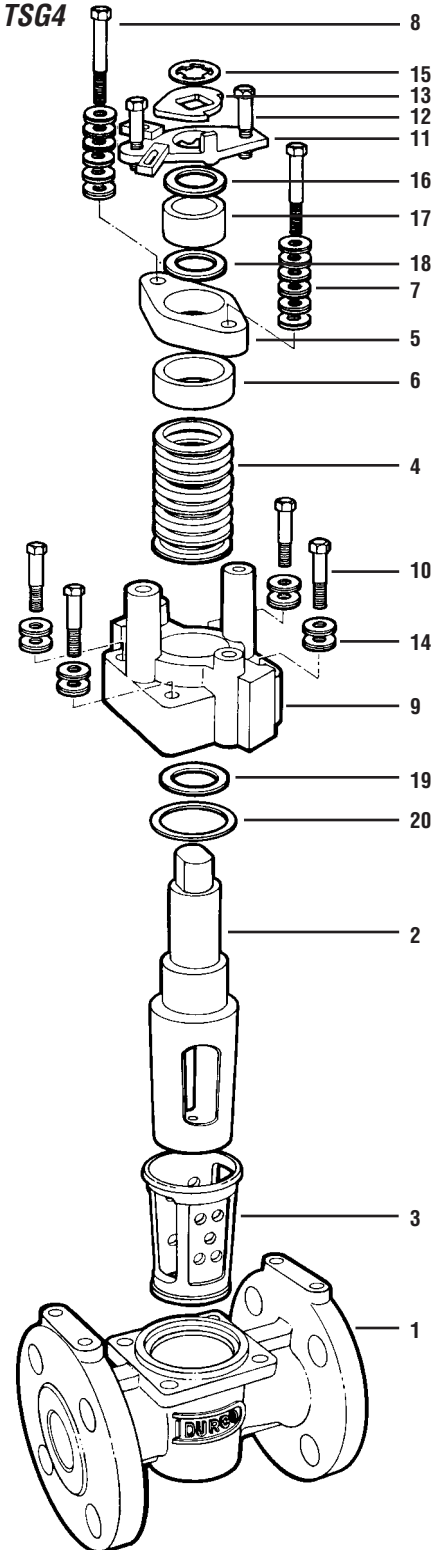

# Testing and Pressure/Temperature Ratings

G4 valves have been extensively tested to ensure the highest level of reliability possible.

The unique reverse lip stem seal has been tested from -50°F (-46°C) to 450°F (232°C) maximum, and with pressures up to 720 psig (4960 kPa).

High temperature throttling tests at 450°F (232°C) with pressure drops of 175 psig (1205 kPa) have proven the superiority of G4 valves over other soft-seated valves. Ask your Durco Valve Sales Representative for specific test results.

The valves have been temperature cycled to 450°F (232°C), and have provided performance superior to any other soft-seated valve available for cyclical temperature situations.

We believe the G4 valve is the best soft-seated valve on the market today, and will outlast and outperform all competitive valves.

### Pressure-Temperature Ratings

The pressure-temperature ratings of all the materials below are based on mechanical property requirements cited in the latest ASME specifications.

The pressure-temperature rating for ductile iron is in agreement with ASME B16.42, 1987.

Valves may require adjustment to remain drop tight at the lower end of temperature range when operating below 0°F (-17°C) or during extreme temperature cycles.

**G4 Pressure/Temperature Ratings Class 150 Valves**

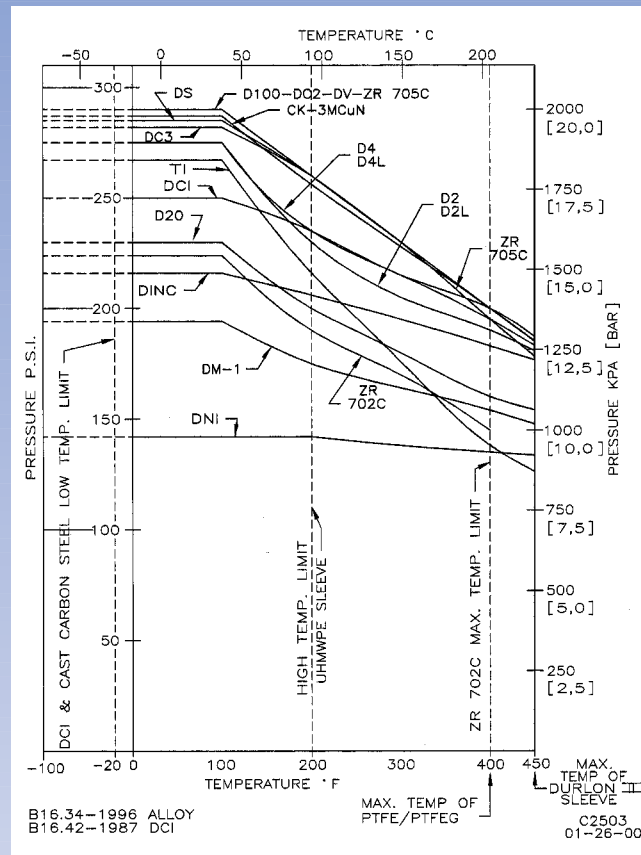

**Class 300 Valves**

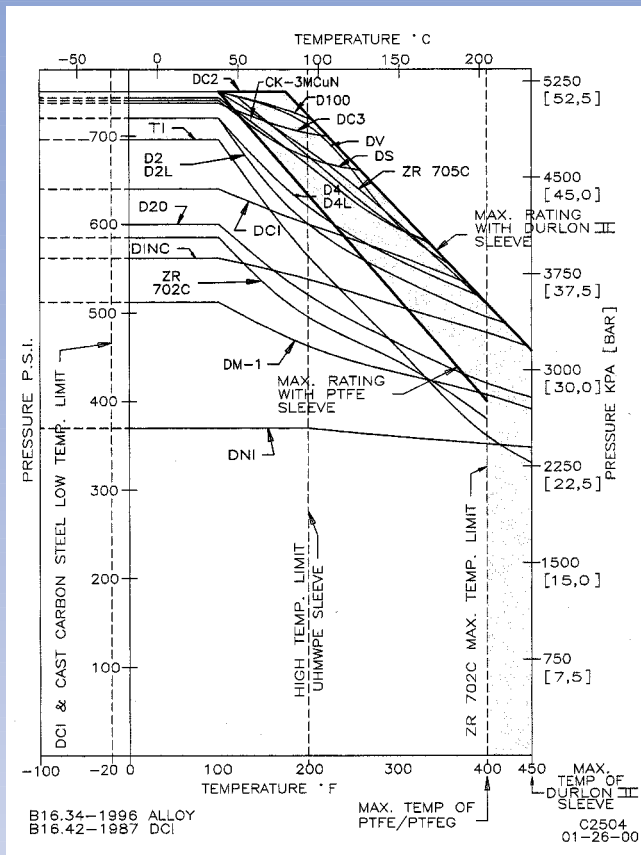

D-20 = Durimet 20 (CN-7M), CD4M = Durcomet 100 (CD-4Mcu), D4 = Cast 316 SS (CF-8M), D4L = Cast 316L SS (CF-3M), D2 = Cast 304 SS (CF-8), D2L = Cast 304L SS (CF-3), DC2 = Chlorimet 2 (N-7M), DC3 = Chlorimet 3 (CW-6M), DINC = Cast Inconel (CY-40), DS = Cast Carbon Steel (WCB), DCI = Ductile Cast Iron (60-40-18), DNI = Cast Nickel (CZ-100), DM-1 = Cast Monel (M-35-1), Zr-705C = Zirconium 705C, Zr-702C = Zirconium 702C, Ti = Titanium, CK-3McuN = 254 SMO

# How To Specify

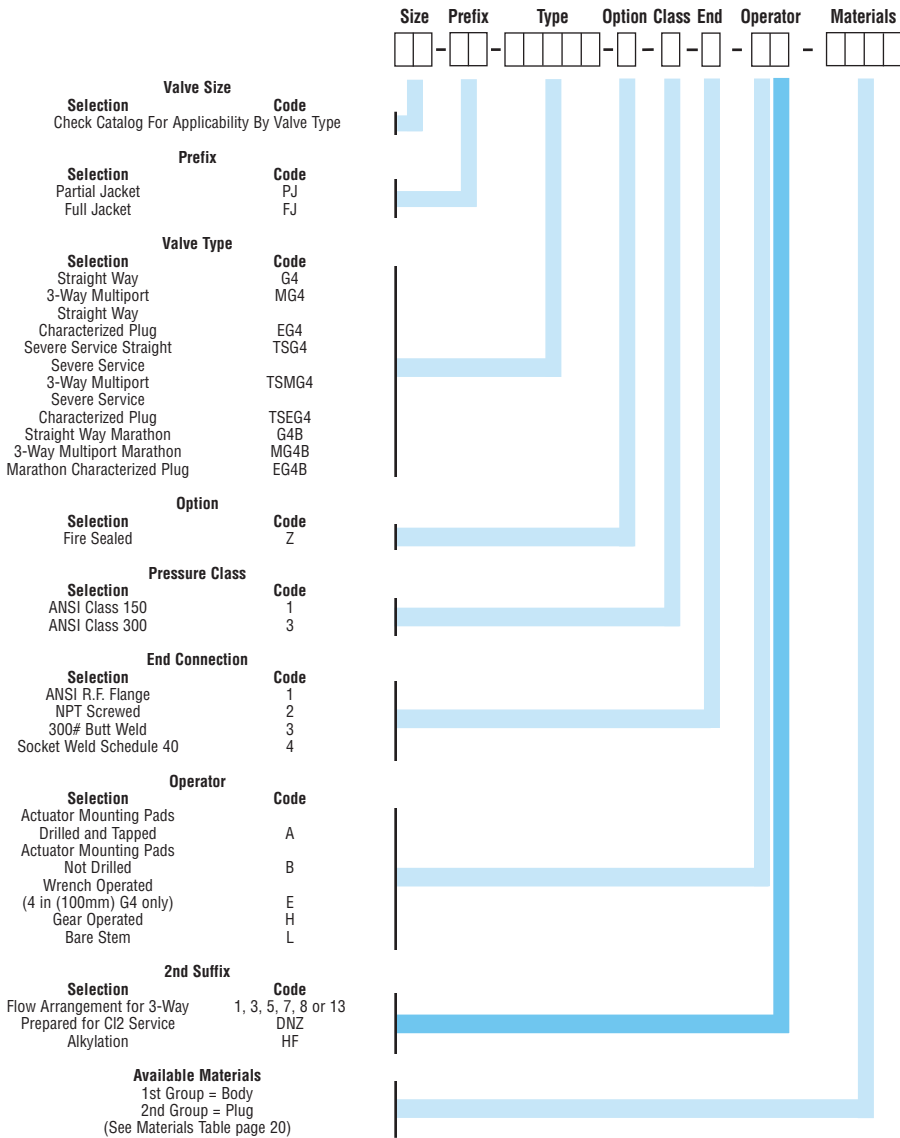

**Selection, Installation, Operation and Maintenance**

Although Flowserve can, and often does, provide general guidelines, it is obviously not possible to provide application specific data and warnings for all conceivable applications. The purchaser/end user must therefore assume the ultimate responsibility for the proper selection, installation, operation and maintenance of the products. Read the appropriate IOM available from Cookeville, TN 38501 before installing, operating or repairing any valve. The purchasers/end user should train its employees and/or contractors in the safe use of the Durco products in connection with the purchaser's manufacturing processes.

**Design Changes**

In order to follow Flowserve's commitment to continuous improvement, we reserve the right to change product and performance specifications without notice.

## Sleeveline Valve Index

Model	Z Fire Sealed	EG V-Port Control	MG 3-Way Multiport	PJ Partially Jacketed	FJ Fully Jacketed	Flanged	Screwed	Socket Weld	Butt Weld	Chlorine	Page No.
G4	•	•	•	•	•	•	•	•	•	•	2
G4Z-HF	•					•	•	•			4
G4B	•	•	•	•	•	•	•	•	•	•	6
TSG4	•	•	•			•	•	•	•	•	8



# Flowserve has the answer to your corrosion resistant, quarter-turn valving needs.

*Clockwise from top right.*

## **Durco® BTV-2000**

PTFE or UHMWPE lined  
chemical service valve

## **Atomac®**

Lined ball valves

- ANSI/ISO, standard and full port
- Specialty valves
- Valve products and accessories

## **Durco® SleeveLine®**

Non-lubricated, PTFE-sleeved  
plug valves

- G4 Isolation
- G4E – DIN Mounting Pad
- G4 Marathon™
- TSG4 Severe Service

## **Durco® T-Line®**

Non-lubricated, PTFE-lined  
plug valves

## **Big Max® Butterfly**

High performance valves

## **Durco® Microfinish™**

Alloy ball valves

## **Automax®**

Valve automation  
systems

- Actuators
- Controls with  
smart technology
- Accessories

*For more information, contact:*



Flowserve Corporation  
Flow Control Division  
1978 Foreman Drive  
Cookeville, Tennessee 38501  
Phone: 931 432 4021  
Fax: 931 432 3105  
[www.flowserve.com](http://www.flowserve.com)



Or Consult Your Local Stocking Distributor

Flowserve Ahaus GmbH  
Von Braun Straße 19a  
D-48683 Ahaus  
Germany  
Phone: +49 2561 686-0  
Fax: +49 2561 686-39

Flowserve Pte. Ltd.  
12 Tuas Avenue 20  
Republic of Singapore 638824  
Phone: 65 862 3332  
Fax: 65 862 2800

Printed in U.S.A.  
March 2002  
© Flowserve Corporation