



[CLICK HERE TO  
START](#)

**PHS**

*Industries, Inc.*

**MULTI-STRUT<sup>®</sup>**

**Channel Framing  
Systems**

**Manufacturers of Pipe Hangers & Supports**

434 Latigue Road, Waggaman, LA 70094

Phone – (504) 431-7722

Fax – (504) 431-7900

Watts – (800) 256-9383

[www.phsind.com](http://www.phsind.com)

# MULTI-STRUT<sup>®</sup>

## Channel Framing Systems



**PHS INDUSTRIES, INC.** has been synonymous with quality and service in the pipe support industry.

As an industry leader, PHS INDUSTRIES, INC. enjoys an international reputation as designers, engineers and manufacturers of pipe hangers, supports, restraints and specialty products to support and control piping systems. Our products have been specified and installed on major power generating stations, petrochemical plants and industrial projects located internationally and throughout the United States.

We are pleased to present this catalog to architects, engineers and construction professionals as an aid in the selection and application of **MULTI-STRUT** products representing one of our most adaptable, versatile and economic product lines designed to meet the challenges of modern construction methods and integrated support systems.

Our sales and engineering groups offer a diversified range of experience in the areas of product design, value engineering, specialized applications and are available to discuss your individual requirements on the basis of function, reliability and manufacturing economy.

# TABLE OF CONTENTS

---

*Simply click on the subject to go to the appropriate page*

Page 4	SECTION I <b>CHANNEL</b>
Page 15	SECTION II <b>GRIP LOCK NUTS &amp; HARDWARE</b>
Page 19	SECTION III <b>PIPE CLAMPS</b>
Page 24	SECTION IV <b>FLAT PLATE/ANGLE BRACKETS/FITTINGS</b>
Page 39	SECTION V <b>ELECTRICAL ACCESSORIES</b>
Page 43	SECTION VI <b>CONCRETE INSERTS/ACCESSORIES</b>
Page 46	SECTION VII <b>TRAPEZES &amp; BRACKETS</b>
Page 50	SECTION VIII <b>MINI-STRUT/MINI-STRUT LOCK NUTS</b>
Page 53	SECTION IX <b>STAINLESS CHANNEL/ACCESSORIES</b>
Page 58	SECTION X <b>SEISMIC RESTRAINTS</b>
Page 66	SECTION XI <b>NON-METALLIC CHANNEL/ACCESSORIES</b>
Page 68	SECTION XII <b>TECHNICAL SECTION AND INDEX</b>

**Catalog No. MS2003e**

**Revision 0**

# METAL FRAMING

- **INSTALLS QUICKLY**
- **COMPLETELY ADJUSTABLE**
- **ELIMINATES ALL WELDING AND USE OF SPECIAL TOOLS**

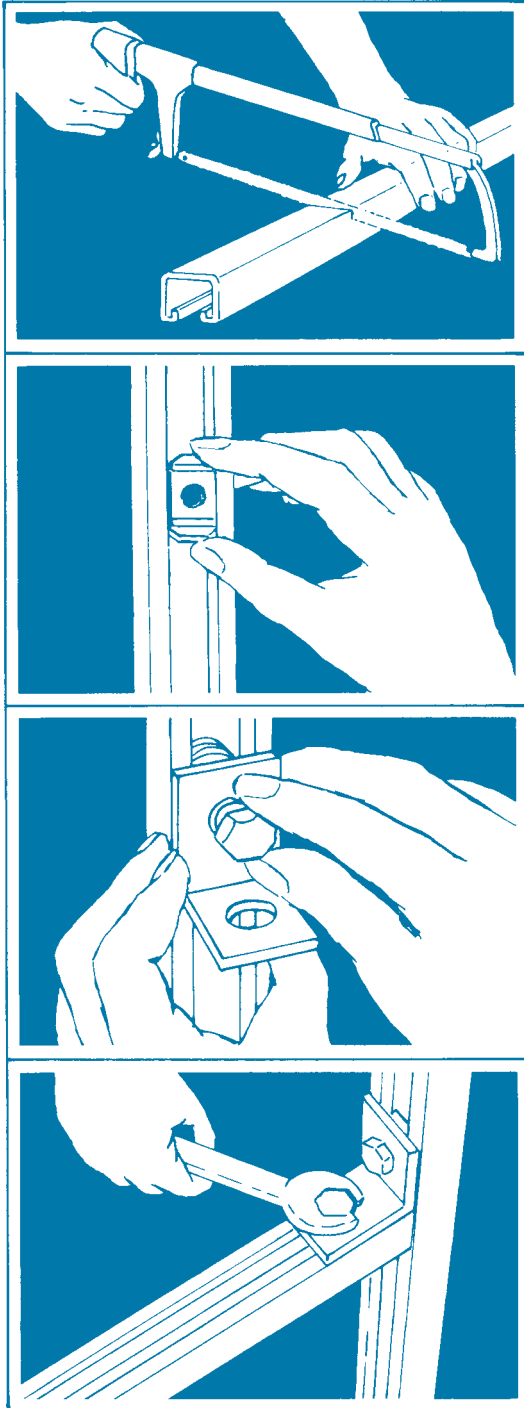

## A SAW, A WRENCH, AND MULTI-STRUT

The Multi-Strut metal framing system provides continuous channel suspension from the planning stages to the actual construction in less time... With less effort.

With Multi-Strut channel and fittings, light-weight suspension systems can be speedily erected in an unlimited variety of styles to meet all structural requirements... Providing a firm anchorage in any type of structure for pipe hangers and supports.

Multi-Strut channel is easily cut into any desired length. In concrete structures, Multi-Strut continuous concrete inserts provide a continuous slotted channel in floors, walls or ceilings.

Multi-Strut insert nuts are placed in the channel slot and positioned at the desired location along the channel. Multi-Strut fittings are then positioned on the nut.

A wrench is applied to the cap screw which causes the serrated grooves in the insert nut to bite into the channel, locking the assembly in place. **NO DRILLING, NO WELDING AND NO SPECIAL TOOLS REQUIRED.**

*This catalog is not designed to show the complete Multi-Strut line of fittings and accessories, but rather to show the most popular items. Hundreds of additional fittings are available for your individual applications.*

# SPECIFICATIONS

---

## Materials

### Channels:

1<sup>5</sup>/<sub>8</sub>" Wide Channel - Pre-Galvanized.  
ASTM - A653 - Grade A - Zinc Coated Sheet by  
Hot Dip Process - Structural Quality.

1<sup>5</sup>/<sub>8</sub>" Wide Channel - Plain/Painted.  
ASTM - A570 - Grade 33 - Hot Rolled Carbon  
Sheet - Structural Quality.

1<sup>3</sup>/<sub>16</sub>" Wide Channel and Closure.  
ASTM - A366 - Cold Rolled Carbon Sheet  
Commercial Quality.

### Fittings:

ASTM - A570 - Hot Rolled Sheet -  
Structural Quality.  
ASTM - A569 - Hot Rolled Sheet -  
Commercial Quality.

### Clamps:

ASTM - A569 - Hot Rolled Sheet -  
Commercial Quality.  
ASTM - A366 - Cold Rolled Sheet -  
Commercial Quality.

### Nuts:

ASTM - A575 - Case Hardened to 3/5 M.  
ASTM - A576 - Case Hardened to 3/5 M.

---

## Finishes

Channels & Closures - Pre-Galvanized.  
ASTM - A525 - G90 - Steel Sheet - Zinc Coated  
by Hot-Dip Process.

Channels & Closures - Painted Green.  
Polyurethane Powder Finish applied by electro-  
static process after formed channel is cleaned  
and phosphated.

Fittings & Clamps - Zinc Coated Electroplating.  
ASTM - B-633, SC1.

# SECTION I 1<sup>5</sup>/<sub>8</sub>" WIDE CHANNELS

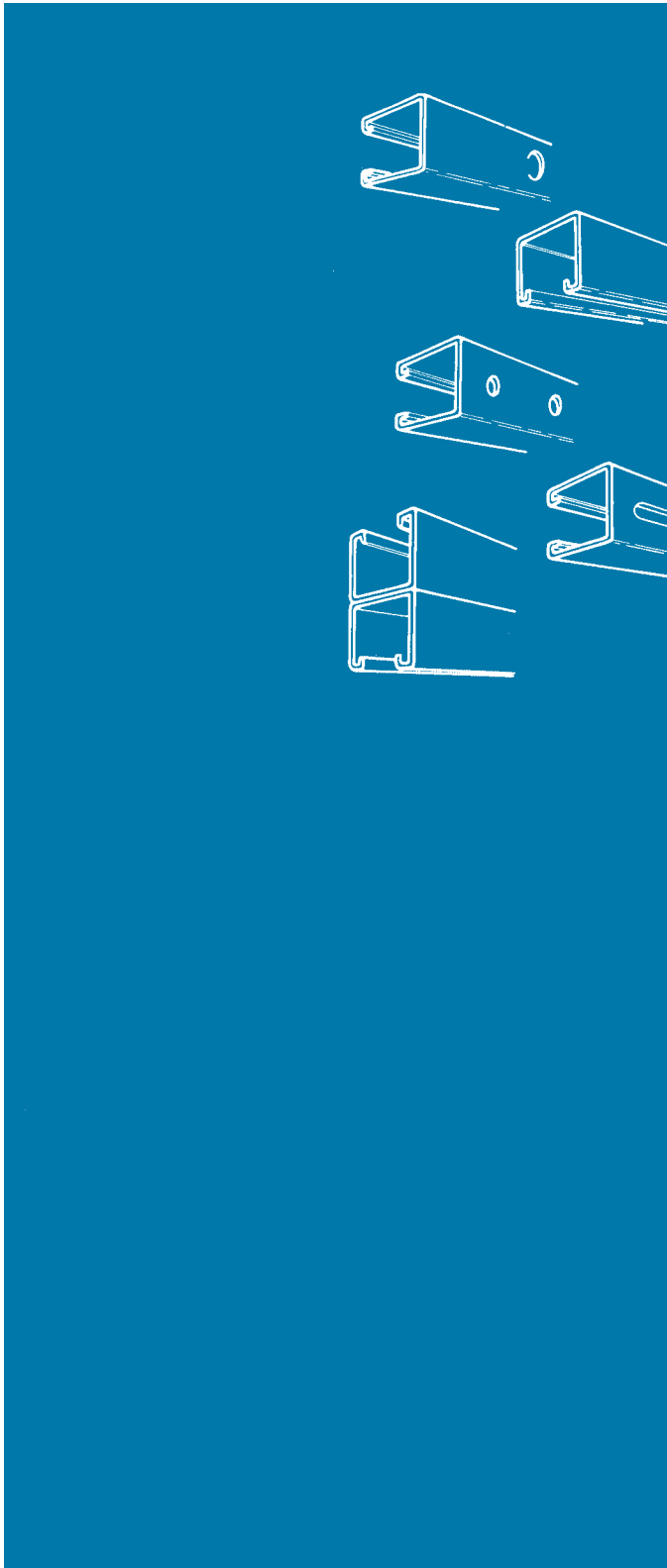

## SPECIFICATIONS

### GENERAL

Multi-Strut channels are manufactured by a series of forming dies or rolls which progressively cold work the strip steel into the desired channel configuration. This method produces a cross section of uniform dimensions within a tolerance of plus or minus .015" on outside dimensions.

### MATERIAL

Multi-Strut channels are produced from prime structural steel covering the following specifications:

HOT DIP PRE-GALVANIZED STEEL .....ASTM 653  
HOT ROLLED STEEL .....ASTM 570  
Other materials and specifications are available upon request.

### WELDING

Channel combinations of two or more elements are spot welded together to form various multiple combinations. See page number 14 for specific combinations and suffix designations.

### LENGTH INFORMATION

Multi-Strut channels are produced and stocked in 10 and 20 foot lengths. Other lengths are available upon request.

### FINISHES

Multi-Strut channels are stocked in plain, pregalvanized and polyurethane green powder coated finish. Other finishes are available upon request.

### ORDERING

Please specify catalog number, finish and length.

### LOADING DATA

- 1) For concentrated beam loads at center span, multiply the load shown in table by .5 and deflection by .8.
- 2) For fabricated channels, reduce the beam loads by the percentage as follows:
  - KO = 5%
  - RS = 10%
  - OS = 15%
  - OS3 = 30%

# CHANNEL/M-112

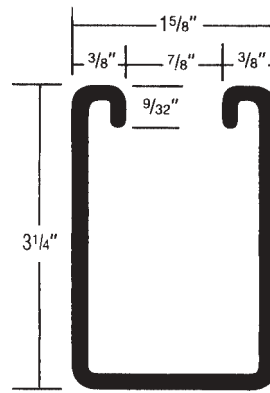

3 1/4" x 1 5/8" x 3/4"  
12 Gauge Channel  
wt./100 ft. - 313#

Stocked in Pre Galvanized, Plain & Painted in 10 & 20 ft. lengths. Post Galvanized & Aluminum available upon request.



**M-112-RS**  
3 1/4" x 1 5/8" x 3/4" x 12GA 9/16"  
Dia.;  
1 7/8" on Centers

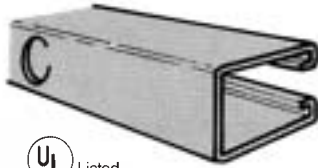

**M-112-KO**  
3 1/4" x 1 5/8" x 3/4" x 12GA 7/8"  
Dia. Knockout;  
6" on Centers



**M-112-OS3**  
3 1/4" x 1 5/8" x 3/4" x 12GA 1 3/32"  
x 3" Slot;  
4" on Centers



**M-112-OS**  
3 1/4" x 1 5/8" x 3/4" x 12GA 9/16"  
x 1 1/8" Slot;  
2" on Centers

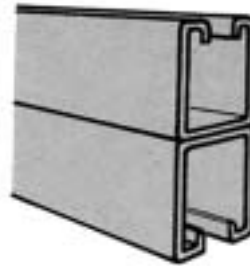

**M-112-A**  
6 1/2" x 1 5/8" X 6 1/2" x 12GA  
Back to Back

\*Other welded combinations available upon request

## PROPERTIES OF SECTION

Figure Number	Wt./Ft. Lbs.	Area of Section Sq. in.	X-X Axis			Y-Y Axis		
			Ix in. <sup>4</sup>	Sx in <sup>3</sup>	Rx in.	Iy in. <sup>4</sup>	Sy in <sup>3</sup>	Ry in.
M-112	3.13	.884	1.073	0.609	1.102	0.429	0.529	0.697
M-112-A	6.26	1.768	6.064	1.896	1.852	0.859	1.0572	0.697

## ALLOWABLE COLUMN LOADS (LBS.)

Figure Number	UNSUPPORTED HEIGHT OF COLUMN IN INCHES												
	12"	18"	24"	30"	36"	42"	48"	60"	72"	84"	96"	108"	120"
M-112	13397	13255	13057	12802	12490	12121	11696	10675	9427	7952	6286	4966	4023
M-112-A	26795	26511	26114	25603	24980	24242	23391	21349	18854	15904	12571	9933	8046

## ALLOWABLE BEAM LOADS (LBS.)

Figure Number	Notes	SPAN IN INCHES												
		12"	18"	24"	30"	36"	42"	48"	60"	72"	84"	96"	108"	120"
M-112	1	10155	6770	5077	4062	3385	2901	2539	2031	1692	1451	1269	1128	1015
	2	-	-	-	-	-	-	-	-	-	1436	1099	869	703
	3	0.007	0.016	0.029	0.045	0.065	0.088	0.115	0.180	0.260	0.354	0.462	0.585	0.722
M-112-A	1	31604	21069	15802	12641	10535	9030	7901	6321	5287	4515	3950	3512	3160
	2	-	-	-	-	-	-	-	-	-	-	-	-	-
	3	0.004	0.009	0.016	0.025	0.036	0.049	0.064	0.099	0.143	0.195	0.254	0.322	0.398

### NOTES:

- I. All Figures show the Load in Lbs.
- II. Line 1 shows the Allowable Uniform Beam Load based on calculations using 25000 psi Stress.
- III. Line 2 shows the Allowable Uniform Load at Maximum Deflection = 1/240 of Span.
- IV. Line 3 shows Beam Deflection in inches.

# CHANNEL/M-122

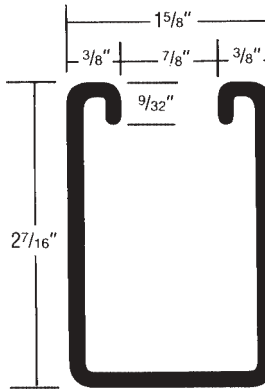

2 7/16" x 1 5/8" x 2 7/16"  
12 Gauge Channel  
wt./100 ft. - 254#

Stocked in Pre Galvanized, Plain & Painted in 10 & 20 ft. lengths. Post Galvanized & Aluminum available upon request.



**M-122-RS**  
2 7/16" x 1 5/8" x 2 7/16" x 12GA  
9/16" Dia.;  
1 7/8" on Centers

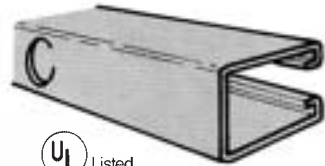

**M-122-KO**  
2 7/16" x 1 5/8" x 2 7/16" x 12GA 7/8"  
Dia. Knockout;  
6" on Centers

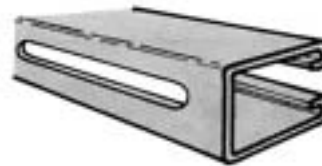

**M-122-OS3**  
2 7/16" x 1 5/8" x 2 7/16" x 12GA  
1 3/32" x 3" Slot;  
4" on Centers



**M-122-OS**  
2 7/16" x 1 5/8" x 2 7/16" x 12GA  
9/16" x 1 1/8" Slot;  
2" on Centers

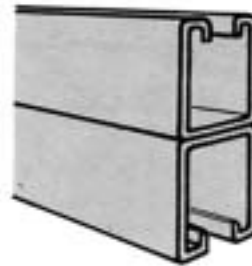

**M-122-A**  
4 7/8" x 1 5/8" X 4 7/8" x 12GA  
Back to Back

\*Other welded combinations available upon request

## PROPERTIES OF SECTION

Figure Number	Wt./Ft. Lbs.	Area of Section Sq. in.	X-X Axis			Y-Y Axis		
			Ix in. <sup>4</sup>	Sx in <sup>3</sup>	Rx in.	Iy in. <sup>4</sup>	Sy in <sup>3</sup>	Ry in.
M-122	2.54	0.714	0.509	0.378	0.844	0.331	0.408	0.681
M-122-A	5.08	1.625	2.721	1.381	1.41	0.663	0.8154	0.681

## ALLOWABLE COLUMN LOADS (LBS.)

Figure Number	UNSUPPORTED HEIGHT OF COLUMN IN INCHES												
	12"	18"	24"	30"	36"	42"	48"	60"	72"	84"	96"	108"	120"
M-122	10496	10380	10217	10007	9751	9449	9100	8262	7237	6027	4705	3717	3011
M-122-A	20992	20760	20434	20015	19503	18897	18199	16523	14475	12054	9408	7434	6022

## ALLOWABLE BEAM LOADS (LBS.)

Figure Number	Notes	SPAN IN INCHES												
		12"	18"	24"	30"	36"	42"	48"	60"	72"	84"	96"	108"	120"
M-122	1	6305	4203	3152	2522	2102	1801	1576	1261	1051	901	788	701	630
	2	-	-	-	-	-	-	-	-	927	681	521	412	334
	3	0.009	0.021	0.038	0.059	0.085	0.116	0.151	0.236	0.340	0.463	0.605	0.765	0.945
M-122-A	1	19014	12676	9507	7606	6338	5433	4654	3803	3169	2716	2377	2113	1901
	2	-	-	-	-	-	-	-	-	-	-	-	-	1784
	3	0.005	0.012	0.021	0.033	0.048	0.065	0.085	0.133	0.192	0.261	0.341	0.432	0.533

### NOTES:

- I. All Figures show the Load in Lbs.
- II. Line 1 shows the Allowable Uniform Beam Load based on calculations using 25000 psi Stress.
- III. Line 2 shows the Allowable Uniform Load at Maximum Deflection = 1/240 of Span.
- IV. Line 3 shows Beam Deflection in inches.



# CHANNEL/M-132

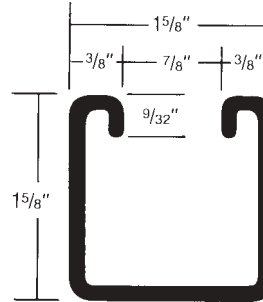

1 5/8" x 1 5/8" x 1 5/8"  
12 Gauge Channel  
wt./100 ft. - 194#

Stocked in Pre Galvanized, Plain & Painted in 10 & 20 ft. lengths. Post Galvanized & Aluminum available upon request.



**M-132-RS**  
1 5/8" x 1 5/8" x 1 5/8" x 12GA 9/16"  
Dia.;  
1 7/8" on Centers



**M-132-KO**  
1 5/8" x 1 5/8" x 1 5/8" x 12GA  
7/8" Dia. Knockout;  
6" on Centers



**M-132-OS3**  
1 5/8" x 1 5/8" x 1 5/8" x 12GA 1 3/32"  
x 3" Slot;  
4" on Centers



**M-132-OS**  
1 5/8" x 1 5/8" x 1 5/8" x 12GA 9/16"  
x 1 1/8" Slot;  
2" on Centers

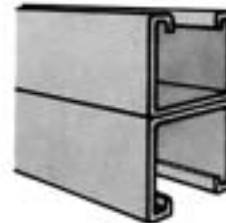

**M-132-A**  
3 1/4" x 1 5/8" X 3 1/4" x 12GA  
Back to Back  
  
\*Other welded combinations available upon request

## PROPERTIES OF SECTION

Figure Number	Wt./Ft. Lbs.	Area of Section Sq. in.	X-X Axis			Y-Y Axis		
			Ix in. <sup>4</sup>	Sx in <sup>3</sup>	Rx in.	Iy in. <sup>4</sup>	Sy in <sup>3</sup>	Ry in.
M-132	1.94	.544	0.180	0.195	0.575	0.233	0.287	0.655
M-132-A	3.88	1.088	0.896	0.570	0.908	0.466	0.5736	0.655

## ALLOWABLE COLUMN LOADS (LBS.)

Figure Number	UNSUPPORTED HEIGHT OF COLUMN IN INCHES												
	12"	18"	24"	30"	36"	42"	48"	60"	72"	84"	96"	108"	120"
M-132	7573	7455	7290	7077	6817	6509	6154	5303	4263	3172	2428	1919	1554
M-132-A	15190	15007	14752	14423	14021	13547	12999	11885	10078	8180	6291	4971	4026

## ALLOWABLE BEAM LOADS (LBS.)

Figure Number	Notes	SPAN IN INCHES												
		12"	18"	24"	30"	36"	42"	48"	60"	72"	84"	96"	108"	120"
M-132	1	3249	2166	1625	1300	1083	928	812	650	542	464	406	361	325
	2	-	-	-	-	-	-	737	472	328	241	184	148	118
	3	0.014	0.031	0.055	0.086	0.124	0.169	0.220	0.344	0.496	0.675	0.882	1.116	1378
M-132-A	1	9496	6331	4748	3799	3185	2713	2374	1899	1583	1357	1187	1055	950
	2	-	-	-	-	-	-	-	-	-	1199	918	725	587
	3	0.008	0.018	0.032	0.051	0.073	0.099	0.129	0.202	0.291	0.396	0.517	0.655	0.808

### NOTES:

- I. All Figures show the Load in Lbs.
- II. Line 1 shows the Allowable Uniform Beam Load based on calculations using 25000 psi Stress.
- III. Line 2 shows the Allowable Uniform Load at Maximum Deflection = 1/240 of Span.
- IV. Line 3 shows Beam Deflection in inches.

# CHANNEL/M-134

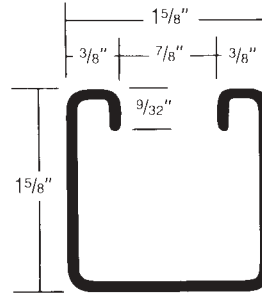

1 5/8" x 1 5/8" x 1 5/8"  
14 Gauge Channel  
wt./100 ft. - 145#

Stocked in Pre Galvanized, Plain & Painted in 10 & 20 ft. lengths. Post Galvanized & Aluminum available upon request.



**M-134-RS**  
1 5/8" x 1 5/8" x 1 5/8" x 14GA 9/16"  
Dia.;  
17/8" on Centers

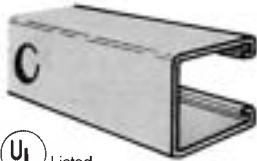

**M-134-KO**  
1 5/8" x 1 5/8" x 1 5/8" x 14GA 7/8"  
Dia. Knockout;  
6" on Centers



**M-134-OS3**  
1 5/8" x 1 5/8" x 1 5/8" x 14GA 13/32"  
x 3" Slot;  
4" on Centers

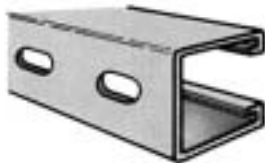

**M-134-OS**  
1 5/8" x 1 5/8" x 1 5/8" x 14GA 9/16"  
x 1 1/8" Slot;  
2" on Centers

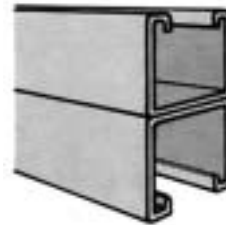

**M-134-A**  
3 1/4" x 1 5/8" X 3 1/4" x 14GA  
Back to Back

\*Other welded combinations available upon request

## PROPERTIES OF SECTION

Figure Number	Wt./Ft. Lbs.	Area of Section Sq. in.	X-X Axis			Y-Y Axis		
			Ix in. <sup>4</sup>	Sx in <sup>3</sup>	Rx in.	Iy in. <sup>4</sup>	Sy in <sup>3</sup>	Ry in.
M-134	1.45	.407	0.143	0.158	0.593	0.179	0.221	0.664
M-134-A	2.90	.814	0.706	0.445	0.931	0.359	0.441	0.664

## ALLOWABLE COLUMN LOADS (LBS.)

Figure Number	UNSUPPORTED HEIGHT OF COLUMN IN INCHES												
	12"	18"	24"	30"	36"	42"	48"	60"	72"	84"	96"	108"	120"
M-134	5906	5819	5698	5542	5352	5126	4867	4243	3481	2630	2013	1591	1288
M-134-A	11839	11701	11508	11259	10954	10595	10180	9184	7967	6528	5042	3983	3227

## ALLOWABLE BEAM LOADS (LBS.)

Figure Number	Notes	SPAN IN INCHES												
		12"	18"	24"	30"	36"	42"	48"	60"	72"	84"	96"	108"	120"
M- 134	1	2631	1754	1316	1052	877	752	658	526	439	376	329	292	263
	2	-	-	-	-	-	-	587	376	261	192	147	116	94
	3	0.014	0.032	0.056	0.088	0.128	0.172	0.224	0.350	0.504	0.687	0.897	1.135	1.401
M- 134-A	1	7409	4939	3704	2963	2470	2117	1852	1482	1235	1058	926	823	741
	2	-	-	-	-	-	-	-	-	-	944	723	571	463
	3	0.008	0.018	0.032	0.050	0.072	0.098	0.128	0.200	0.288	0.392	0.512	0.649	0.081

### NOTES:

- I. All Figures show the Load in Lbs.
- II. Line 1 shows the Allowable Uniform Beam Load based on calculations using 25000 psi Stress.
- III. Line 2 shows the Allowable Uniform Load at Maximum Deflection = 1/240 of Span.
- IV. Line 3 shows Beam Deflection in inches.

# CHANNEL/M-142



**M-142-RS**  
 $1\frac{3}{8}" \times 1\frac{5}{8}" \times 1\frac{3}{8}" \times 12GA \frac{9}{16}"$   
 Dia.;  
 $1\frac{7}{8}"$  on Centers

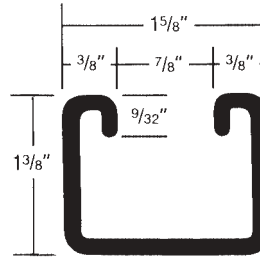

$1\frac{3}{8}" \times 1\frac{5}{8}" \times 1\frac{3}{8}"$   
 12 Gauge Channel  
 wt./100 ft. - 176#

Stocked in Pre Galvanized, Plain & Painted in 10 & 20 ft. lengths. Post Galvanized & Aluminum available upon request.

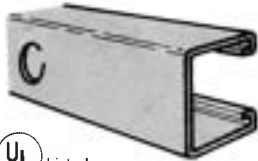

**M-142-KO**  
 $1\frac{3}{8}" \times 1\frac{5}{8}" \times 1\frac{3}{8}" \times 12GA \frac{7}{8}"$   
 Dia. Knockout;  
 6" on Centers

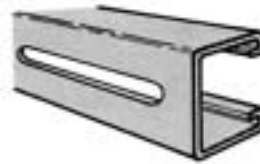

**M-142-OS3**  
 $1\frac{3}{8}" \times 1\frac{5}{8}" \times 1\frac{3}{8}" \times 12GA \frac{13}{32}"$   
 x 3" Slot;  
 4" on Centers

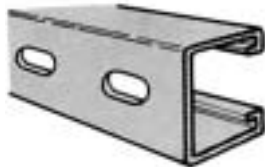

**M-142-OS**  
 $1\frac{3}{8}" \times 1\frac{5}{8}" \times 1\frac{3}{8}" \times 12GA \frac{9}{16}"$   
 x  $1\frac{1}{8}"$  Slot;  
 2" on Centers

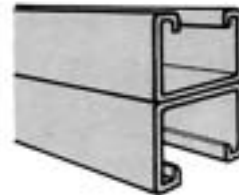

**M-142-A**  
 $2\frac{3}{4}" \times 1\frac{5}{8}" \times 2\frac{3}{4}" \times 12GA$   
 Back to Back

\*Other welded combinations available upon request

## PROPERTIES OF SECTION

Figure Number	Wt./Ft. Lbs.	Area of Section Sq. in.	X-X Axis			Y-Y Axis		
			Ix in. <sup>4</sup>	Sx in <sup>3</sup>	Rx in.	Iy in. <sup>4</sup>	Sy in <sup>3</sup>	Ry in.
M-142	1.76	0.492	0.117	0.148	0.489	0.203	0.250	0.642
M-142-A	3.52	0.983	0.570	0.431	0.762	0.408	0.50	0.642

## ALLOWABLE COLUMN LOADS (LBS.)

Figure Number	UNSUPPORTED HEIGHT OF COLUMN IN INCHES												
	12"	18"	24"	30"	36"	42"	48"	60"	72"	84"	96"	108"	120"
M-142	6653	6509	6306	6046	5727	5351	4917	3876	2749	2020	1547	1222	990
M-142-A	13404	13237	13002	12701	12333	11898	11396	10191	8718	6978	5347	4225	3422

## ALLOWABLE BEAM LOADS (LBS.)

Figure Number	Notes	SPAN IN INCHES												
		12"	18"	24"	30"	36"	42"	48"	60"	72"	84"	96"	108"	120"
M-142	1	2473	1649	1236	989	824	707	618	495	412	353	309	275	247
	2	-	-	-	-	-	628	481	308	214	157	120	95	77
	3	0.016	0.036	0.064	0.100	0.145	0.197	0.257	0.402	0.579	0.788	1.029	1.302	1.608
M-142-A	1	7187	4791	3593	2875	2396	2053	1797	1437	1198	1027	898	799	719
	2	-	-	-	-	-	-	-	-	1039	763	584	462	374
	3	0.010	0.022	0.038	0.060	0.086	0.118	0.154	0.240	0.346	0.471	0.615	0.778	0.961

### NOTES:

- I. All Figures show the Load in Lbs.
- II. Line 1 shows the Allowable Uniform Beam Load based on calculations using 25000 psi Stress.
- III. Line 2 shows the Allowable Uniform Load at Maximum Deflection = 1/240 of Span.
- IV. Line 3 shows Beam Deflection in inches.

# CHANNEL/M-152

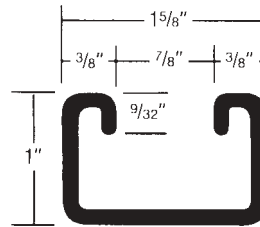

1" x 1 5/8" x 1"  
12 Gauge Channel  
wt./100 ft. - 149#

Stocked in Pre Galvanized, Plain & Painted in 10 & 20 ft. lengths. Post Galvanized & Aluminum available upon request.

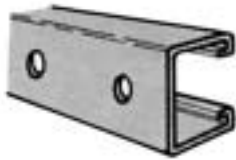

**M-152-RS**  
1" x 1 5/8" x 1" x 12GA  
9/16" Dia.;  
1 7/8" on Centers

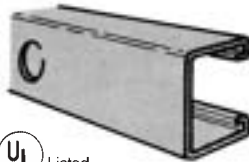

**M-152-KO**  
1" x 1 5/8" x 1" x 12GA  
7/8" Dia. Knockout;  
6" on Centers

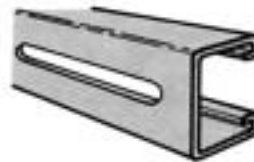

**M-152-OS3**  
1" x 1 5/8" x 1" x 12GA  
1 3/32" x 3" Slot;  
4" on Centers



**M-152-OS**  
1" x 1 5/8" x 1" x 12GA  
9/16" x 1 1/8" Slot;  
2" on Centers

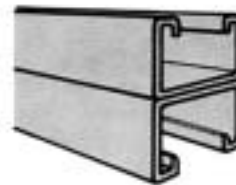

**M-152-A**  
2" x 1 5/8" X 2" x 12GA  
Back to Back

\*Other welded combinations available upon request

## PROPERTIES OF SECTION

Figure Number	Wt./Ft. Lbs.	Area of Section Sq. in.	X-X Axis			Y-Y Axis		
			Ix in. <sup>4</sup>	Sx in <sup>3</sup>	Rx in.	Iy in. <sup>4</sup>	Sy in <sup>3</sup>	Ry in.
M-152	1.49	.413	0.052	0.088	0.353	0.157	0.194	0.617
M-152-A	2.98	.826	0.243	0.256	0.542	0.315	0.3876	0.617

## ALLOWABLE COLUMN LOADS (LBS.)

Figure Number	UNSUPPORTED HEIGHT OF COLUMN IN INCHES												
	12"	18"	24"	30"	36"	42"	48"	60"	72"	84"	96"	108"	120"
M-152	5243	5022	4712	4314	3827	3251	2592	1659	1152	846	648	512	415
M-152-A	10691	10502	10239	9900	9486	8997	8433	7078	5422	3984	3050	2410	1952

## ALLOWABLE BEAM LOADS (LBS.)

Figure Number	Notes	SPAN IN INCHES												
		12"	18"	24"	30"	36"	42"	48"	60"	72"	84"	96"	108"	120"
M-152	1	1480	973	730	584	487	417	365	292	243	209	183	162	146
	2	-	-	-	541	376	276	211	135	94	69	53	42	34
	3	0.022	0.049	0.086	0.135	0.194	0.284	0.345	0.540	0.777	1.058	1.381	1.748	2.158
M-152-A	1	4270	2947	2135	1708	1423	1220	1067	854	712	610	534	474	427
	2	-	-	-	-	-	-	995	637	442	325	249	197	159
	3	0.013	0.030	0.054	0.084	0.121	0.164	0.215	0.335	0.483	0.657	0.858	1.086	1.341

### NOTES:

- I. All Figures show the Load in Lbs.
- II. Line 1 shows the Allowable Uniform Beam Load based on calculations using 25000 psi Stress.
- III. Line 2 shows the Allowable Uniform Load at Maximum Deflection = 1/240 of Span.
- IV. Line 3 shows Beam Deflection in inches.

# CHANNEL/M-164

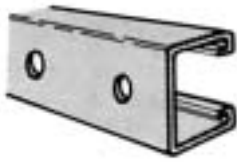

### M-164-RS

1 3/16" x 1 5/8" x 1 3/16" x 14GA 9/16"  
Dia.;  
1 7/8" on Centers

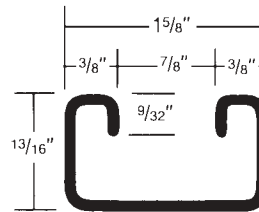

1 3/16" x 1 5/8" x 1 3/16"  
14 Gauge Channel  
wt./100 ft. - 103#

Stocked in Pre Galvanized, Plain & Painted in 10 & 20 ft. lengths. Post Galvanized & Aluminum available upon request.



### M-164-KO

1 3/16" x 1 5/8" x 1 3/16" x 14GA 7/8"  
Dia. Knockout;  
6" on Centers



### M-164-OS3

1 3/16" x 1 5/8" x 1 3/16" x 14GA  
1 3/32" x 3" Slot;  
4" on Centers



### M-164-OS

1 3/16" x 1 5/8" x 1 3/16" x 14GA 9/16"  
x 1 1/8" Slot;  
2" on Centers

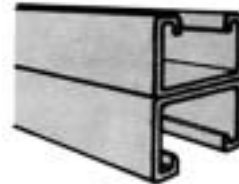

### M-164-A

1 5/8" x 1 5/8" x 1 5/8" x 14GA  
Back to Back

\*Other welded combinations available upon request

## PROPERTIES OF SECTION

Figure Number	Wt./Ft. Lbs.	Area of Section Sq. in.	X-X Axis			Y-Y Axis		
			Ix in. <sup>4</sup>	Sx in <sup>3</sup>	Rx in.	Iy in. <sup>4</sup>	Sy in <sup>3</sup>	Ry in.
M-164	1.03	0.286	0.025	0.053	0.298	0.106	0.131	0.610
M-164-A	2.06	0.571	0.115	0.149	0.449	0.213	0.2619	0.610

## ALLOWABLE COLUMN LOADS (LBS.)

Figure Number	UNSUPPORTED HEIGHT OF COLUMN IN INCHES												
	12"	18"	24"	30"	36"	42"	48"	60"	72"	84"	96"	108"	120"
M-164	3710	3487	3175	2773	2282	1729	1324	847	588	432	331	261	212
M-164-A	7620	7424	7148	6795	6362	5851	5261	3847	2671	1963	1503	1187	962

## ALLOWABLE BEAM LOADS (LBS.)

Figure Number	Notes	SPAN IN INCHES												
		12"	18"	24"	30"	36"	42"	48"	60"	72"	84"	96"	108"	120"
M-164	1	888	592	444	355	296	254	222	178	148	127	111	99	89
	2	-	-	416	266	185	136	104	67	46	34	26	21	17
	3	0.027	0.060	0.107	0.167	0.240	0.327	0.427	0.667	0.960	1.307	1.708	2.161	2.668
M-164-A	1	2478	1652	1239	991	826	708	619	496	413	354	310	275	248
	2	-	-	-	-	-	617	472	302	210	154	118	93	76
	3	0.016	0.037	0.066	0.102	0.148	0.201	0.262	0.410	0.590	0.804	1.050	1.328	1.640

### NOTES:

- I. All Figures show the Load in Lbs.
- II. Line 1 shows the Allowable Uniform Beam Load based on calculations using 25000 psi Stress.
- III. Line 2 shows the Allowable Uniform Load at Maximum Deflection = 1/240 of Span.
- IV. Line 3 shows Beam Deflection in inches.

# CHANNEL/M-165

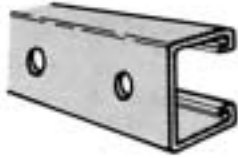

**M-165-RS**  
 $1\frac{3}{16}'' \times 1\frac{5}{8}'' \times 1\frac{3}{16}'' \times 15GA$   $\frac{9}{16}''$  Dia.;  
 $1\frac{7}{8}''$  on Centers

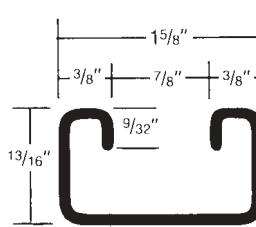

$1\frac{3}{16}'' \times 1\frac{5}{8}'' \times 1\frac{3}{16}''$   
 15 Gauge Channel  
 wt./100 ft. - 94#

Stocked in Pre Galvanized, Plain & Painted in 10 & 20 ft. lengths. Post Galvanized & Aluminum available upon request.

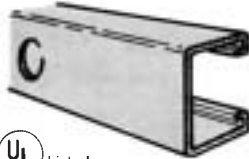

**M-165-KO**  
 $1\frac{3}{16}'' \times 1\frac{5}{8}'' \times 1\frac{3}{16}'' \times 15GA$   $\frac{7}{8}''$  Dia. Knockout;  
 6" on Centers



**M-165-OS3**  
 $1\frac{3}{16}'' \times 1\frac{5}{8}'' \times 1\frac{3}{16}'' \times 15GA$   
 $1\frac{3}{32}'' \times 3''$  Slot;  
 4" on Centers



**M-165-OS**  
 $1\frac{3}{16}'' \times 1\frac{5}{8}'' \times 1\frac{3}{16}'' \times 15GA$   $\frac{9}{16}'' \times 1\frac{1}{8}''$  Slot;  
 2" on Centers

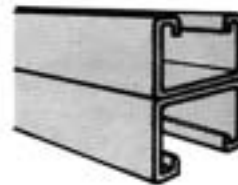

**M-165-A**  
 $1\frac{5}{8}'' \times 1\frac{5}{8}'' \times 1\frac{5}{8}'' \times 15GA$   
 Back to Back

\*Other welded combinations available upon request

## PROPERTIES OF SECTION

Figure Number	Wt./Ft. Lbs.	Area of Section Sq. in.	X-X Axis			Y-Y Axis		
			Ix in. <sup>4</sup>	Sx in <sup>3</sup>	Rx in.	Iy in. <sup>4</sup>	Sy in <sup>3</sup>	Ry in.
M-165	.94	0.261	0.024	0.050	0.302	0.098	0.121	0.613
M-165-A	1.88	0.523	0.107	0.138	0.453	0.196	0.2416	0.613

## ALLOWABLE COLUMN LOADS (LBS.)

Figure Number	UNSUPPORTED HEIGHT OF COLUMN IN INCHES												
	12"	18"	24"	30"	36"	42"	48"	60"	72"	84"	96"	108"	120"
M-165	3435	3250	2967	2603	2157	1647	1261	807	560	412	315	249	202
M-165-A	7086	6906	6655	6332	5937	5471	4932	3640	2528	1857	1422	1124	910

## ALLOWABLE BEAM LOADS (LBS.)

Figure Number	Notes	SPAN IN INCHES												
		12"	18"	24"	30"	36"	42"	48"	60"	72"	84"	96"	108"	120"
M-165	1	837	558	418	335	279	239	209	167	139	120	105	93	84
	2	-	-	390	250	173	127	98	62	43	32	24	19	16
	3	0.027	0.060	0.107	0.168	0.241	0.328	0.429	0.670	0.965	1.313	1.715	2.171	2.680
M-165-A	1	2298	1532	1149	919	766	657	575	460	383	328	287	255	230
	2	-	-	-	-	-	575	440	282	196	144	110	87	70
	3	0.016	0.037	0.065	0.102	0.147	0.200	0.261	0.408	0.588	0.800	1.045	1.322	1.632

### NOTES:

- I. All Figures show the Load in Lbs.
- II. Line 1 shows the Allowable Uniform Beam Load based on calculations using 25000 psi Stress.
- III. Line 2 shows the Allowable Uniform Load at Maximum Deflection = 1/240 of Span.
- IV. Line 3 shows Beam Deflection in inches.

# CHANNEL/M-172



**M-172-RS**  
 7/8" x 1 5/8" x 7/8" x 12GA  
 9/16" Dia.;  
 1 7/8" on Centers

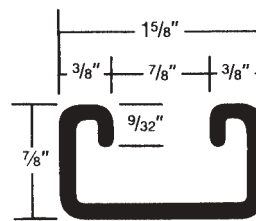

7/8" x 1 5/8" x 7/8"  
 12 Gauge Channel  
 wt./100 ft. - 139#

Stocked in Pre Galvanized, Plain & Painted in 10 & 20 ft. lengths. Post Galvanized & Aluminum available upon request.



**M-172-KO**  
 7/8" x 1 5/8" x 7/8" x 12GA  
 7/8" Dia. Knockout;  
 6" on Centers



**M-172-OS3**  
 7/8" x 1 5/8" x 7/8" x 12GA  
 1 3/32" x 3" Slot;  
 4" on Centers



**M-172-OS**  
 7/8" x 1 5/8" x 7/8" x 12GA  
 9/16" x 1 1/8" Slot;  
 2" on Centers

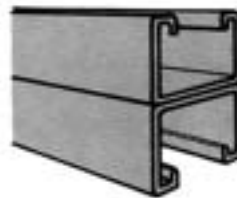

**M-172-A**  
 1 3/4" x 1 5/8" X 1 3/4" x 12GA  
 Back to Back  
 \*Other welded combinations available upon request

## PROPERTIES OF SECTION

Figure Number	Wt./Ft. Lbs.	Area of Section Sq. in.	X-X Axis			Y-Y Axis		
			Ix in. <sup>4</sup>	Sx in <sup>3</sup>	Rx in.	Iy in. <sup>4</sup>	Sy in <sup>3</sup>	Ry in.
M-172	1.39	0.387	0.036	0.070	0.307	0.142	0.175	0.607
M-172-A	2.78	0.774	0.170	0.207	0.469	0.285	0.350	0.607

## ALLOWABLE COLUMN LOADS (LBS.)

Figure Number	UNSUPPORTED HEIGHT OF COLUMN IN INCHES												
	12"	18"	24"	30"	36"	42"	48"	60"	72"	84"	96"	108"	120"
M-172	4755	4485	4108	3622	3029	2337	1789	1145	795	584	447	353	286
M-172-A	9758	9527	9204	8788	8280	7680	6988	5326	3718	2731	2091	1652	1338

## ALLOWABLE BEAM LOADS (LBS.)

Figure Number	Notes	SPAN IN INCHES												
		12"	18"	24"	30"	36"	42"	48"	60"	72"	84"	96"	108"	120"
M-172	1	1165	776	582	466	388	333	291	233	194	166	146	129	116
	2	-	-	-	381	265	195	149	95	66	49	37	29	24
	3	0.024	0.055	0.098	0.153	0.220	0.299	0.391	0.611	0.879	1.197	1.563	1.979	2.443
M-172-A	1	3445	2296	1722	1378	1148	984	861	689	574	492	431	383	344
	2	-	-	-	-	-	910	697	446	310	227	174	138	111
	3	0.015	0.035	0.062	0.097	0.139	0.189	0.247	0.386	0.556	0.757	0.989	1.252	1.545

### NOTES:

- I. All Figures show the Load in Lbs.
- II. Line 1 shows the Allowable Uniform Beam Load based on calculations using 25000 psi Stress.
- III. Line 2 shows the Allowable Uniform Load at Maximum Deflection = 1/240 of Span.
- IV. Line 3 shows Beam Deflection in inches.

# WELDED COMBINATIONS

(Available in all Channels)

**Suffix 'B'**

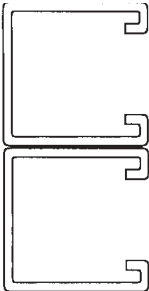

**Suffix 'C'**

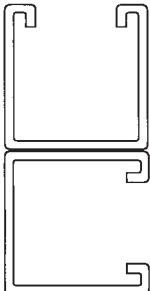

**Suffix 'D'**

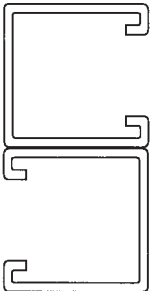

**Suffix 'C1'**

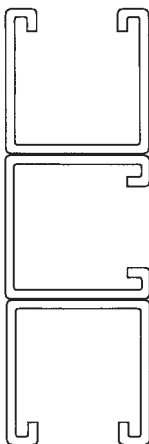

**Suffix 'C2'**

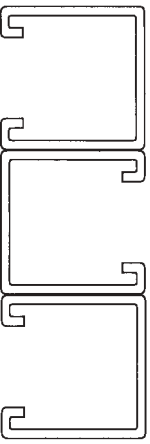

**Suffix 'A4'**

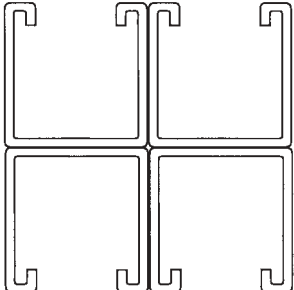

Ordering Information:  
Specify channel catalog number followed by applicable suffix designation.





# GRIP LOCK NUTS

**DATA:**

Finished in Electro-Galvanized

The case hardened carbon steel nuts are designed with special formed teeth in the parallel channel recesses. The nuts are made to grip the returned lip of the channel. The shearing action of the teeth assures a positive locking of the H-Strut channels to the fittings. The selection table shows the correct locking nuts for each size channel.

**WITHOUT SPRING**

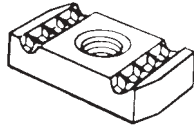

Cat. No.	Size	Thd	Thk	Wt/100 pc.	Channel
N-800	1/4"	20	1/4"	6	All Multi-Strut
N-801	3/8"	16	3/8"	9	
N-802	1/2"	13	3/8"	9	
N-803	1/2"	13	1/2"	12	M-122, M-132, M-134
N-804	5/8"	11	7/16"	13	M-142, M-152, M-164
N-805	3/4"	10	7/16"	13	M-165, M-166, M-112
N-806	5/8"	11	3/8"	13	All Multi-Strut
N-807	3/4"	10	3/8"	13	
N-808	5/16"	18	3/8"	7	
N-809	7/8"	9	7/16"	13	

**SHORT SPRING**

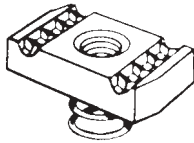

Cat. No.	Size	Thd	Thk	Wt/100 pc.	Channel
N-810	1/4"	20	1/4"	7	M-152, M-164, M-165
N-811	3/8"	16	3/8"	9	
N-812	1/2"	13	3/8"	9	
N-814	3/8"	11	3/8"	10	M-166
N-815	3/4"	10	3/8"	9	
N-818	5/16"	18	3/8"	7	

**REGULAR SPRING**

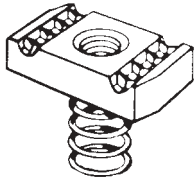

Cat. No.	Size	Thd	Thk	Wt/100 pc.	Channel
N-820	1/4"	20	1/4"	7	M-132, M-134, M-142
N-821	3/8"	16	3/8"	10	
N-822	1/2"	13	3/8"	10	
N-823	1/2"	13	1/2"	13	
N-824	5/8"	11	7/16"	13	
N-825	3/4"	10	7/16"	13	
N-828	5/16"	18	3/8"	7	
N-829	7/8"	9	7/16"	13	

**LONG SPRING**

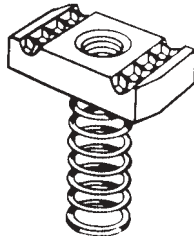

Cat. No.	Size	Thd	Thk	Wt/100 pc.	Channel
N-830	1/4"	20	1/4"	7	M-122, M-112
N-831	3/8"	16	3/8"	10	
N-832	1/2"	13	3/8"	10	
N-833	1/2"	13	1/2"	13	
N-834	5/8"	11	7/16"	13	
N-835	3/4"	10	7/16"	13	
N-838	5/16"	18	3/8"	7	

**TOP SPRING NUT**

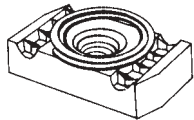

Cat. No.	Size	Thd	Thk	Wt/100 pc.	Channel
TSN-800	1/4"	20	1/4"	6	All Multi-Strut
TSN-801	3/8"	16	3/8"	9	
TSN-802	1/2"	13	3/8"	9	
TSN-808	5/16"	18	3/8"	7	

**NOTE:**

1. Tests performed with 1/2" - 13 Bolt tightened to 50/Ft./Lbs. torque
2. Tests performed in accordance with, "The Metal Framing Manufacturers Association" 1983 Specifications.
3. Safety Factor of 3

**LOAD DATA**

RESISTANCE TO SLIP	PULL OUT STRENGTH
12 Gauge - 1,400#	12 Gauge - 2,000#
14 Gauge - 1,100#	14 Gauge - 1,1400#
15 Gauge - 1,100#	15 Gauge - 1,100#

# THREADED FASTENERS

## HEX HEAD CAP SCREWS

Finished in Electro-Galvanized  
For use with Grip Lock Nuts to secure fittings to channels.

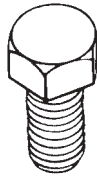

Diameter	Length	Wt/C	Diameter	Length	Wt/C
1/4"	1/2"	1.0	3/8"	2 1/4"	8.5
1/4"	3/4"	1.3	1/2"	1"	9.1
1/4"	1"	1.7	1/2"	1 1/4"	10.0
3/8"	3/4"	4.0	1/2"	1 1/2"	11.6
3/8"	1"	4.5	1/2"	1 3/4"	13.2
3/8"	1 1/4"	5.3	1/2"	2"	14.7
3/8"	1 1/2"	6.1	1/2"	2 1/4"	16.0
3/8"	2"	7.6	1/2"	2 1/2"	17.5

## FLAT HEAD MACHINE SCREWS

FINISH: Electro-Galvanized

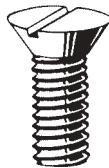

Diameter	Length	Wt/C
1/4"	5/8"	1.2
5/16"	1"	2.6
3/8"	2"	6.5
3/8"	2 1/4"	7.1
3/8"	2 1/2"	7.7

## ROUND HEAD MACHINE SCREWS

FINISH: Electro-Galvanized



Diameter	Length	Wt/C	Diameter	Length	Wt/C
1/4"	3/4"	1.2	5/16"	1 1/2"	3.6
1/4"	1"	1.5	3/8"	1"	4.1
1/4"	1 1/4"	1.8	3/8"	1 1/4"	4.7
5/16"	1"	2.6	3/8"	1 1/2"	5.3
5/16"	1 1/4"	3.0	3/8"	2 1/2"	7.7

## LOCK WASHERS

FINISH: Electro-Galvanized



Size	Wt/C
1/4"	.3
3/8"	.7
1/2"	1.5

## FLAT WASHERS

FINISH: Electro-Galvanized



Size	Wt/C
1/4"	.7
3/8"	1.5
1/2"	3.5

## HEX NUTS

FINISH: Electro-Galvanized



Size	Wt/C
1/4"	.6
5/16"	1.2
3/8"	1.6
1/2"	4.8

## SQUARE NUTS

FINISH: Electro-Galvanized

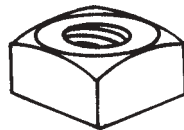

Size	Wt/C
1/4"	.9
5/16"	1.6
3/8"	2.7
1/2"	5.8

# THREADED FASTENERS

## ALL-THREAD ROD

FINISH: Electro-Galvanized  
Length: 6"

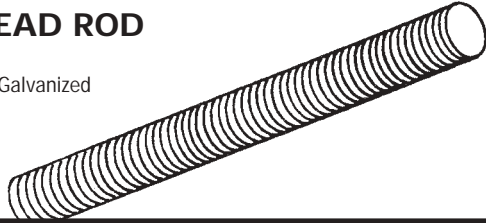

Dia.	Thd	Wt/100
1/4"	20	12
3/8"	16	30
1/2"	13	54
5/8"	11	85
3/4"	10	125

## ROD COUPLERS

FINISH: Electro-Galvanized

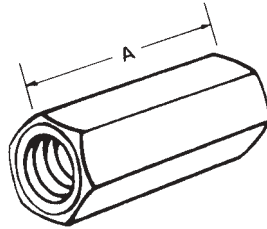

Hole Size	Thd	"A" Length	Wt Lbs/C
1/4"	20	7/8"	2#
3/8"	16	1 1/4"	11#
1/2"	13	1 3/4"	11#
5/8"	11	2 1/8"	16#
3/4"	10	2 1/4"	28#

## "U" BOLTS

FINISH: Electro-Galvanized

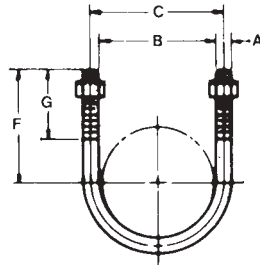

Pipe Size	Max. Recom. Load, lb.	A	B	C	F	G	Weight per 100
1/2"	480	1/4"	7/8"	1 1/8"	1 1/4"	3/4"	8
3/4"	480	1/4"	1 1/8"	1 3/8"	1 3/8"	3/4"	9
1"	480	1/4"	1 3/8"	1 5/8"	1 3/8"	3/4"	10
1 1/4"	1200	3/8"	1 3/4"	2 1/8"	1 3/4"	1"	27
1 1/2"	1200	3/8"	2"	2 3/8"	1 7/8"	1"	30
2"	1200	3/8"	2 1/2"	2 7/8"	2 1/4"	1"	34
2 1/2"	2200	1/2"	3"	3 1/2"	2 5/8"	1 1/4"	72
3"	2200	1/2"	3 5/8"	4 1/8"	3 1/4"	1 1/4"	80
4"	2200	1/2"	4 5/8"	5 1/8"	3 1/2"	1 1/4"	95
5"	2200	1/2"	5 5/8"	6 1/8"	4 1/4"	1 1/4"	113
6"	3600	5/8"	6 3/4"	7 3/8"	4 3/4"	1 1/4"	124
8"	3600	5/8"	8 3/4"	9 3/8"	5 5/8"	1 1/4"	210
10"	5400	3/4"	10 7/8"	11 5/8"	7"	1 1/2"	268
12"	7500	7/8"	12 7/8"	13 3/4"	7 7/8"	1 1/2"	320

## N-8771 DOUBLE NUT

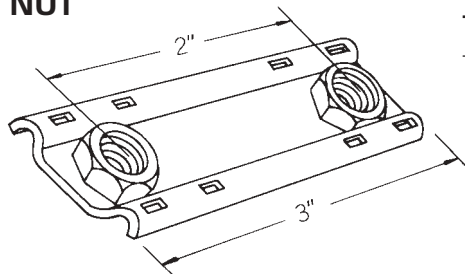

Cat. No.	Size	Thd	Weight per 100
N-8771	38	16	175

## SECTION III PIPE CLAMPS AND SUPPORTS

---

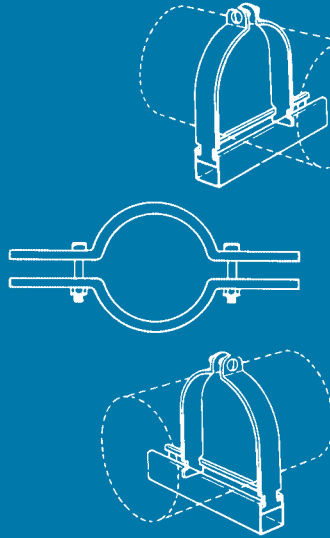

### SPECIFICATIONS

#### GENERAL

Multi-Strut pipe clamps are designed to fit into the channel openings for the support of runs of piping where it is desired to clamp the pipe into place.

#### MATERIAL

Multi-Strut pipe clamps are manufactured from steel strip which is punch-press formed. All clamps are 1 $\frac{5}{8}$ " wide and all holes are  $\frac{9}{16}$ " in diameter. The above dimensions apply to all clamps except where noted.

#### FINISH

Multi-Strut pipe clamps and supports are stocked in electro-galvanized finish, and many of the C-1101 sizes are stocked in a copper plated finish. Other finishes are available upon request.

#### ORDERING

Please specify catalog number, size and finish.

- Reduces noise due to shock and vibration
- Eliminates metal to metal contact
- Usable temperatures from +275°F to -65°F
- Fast and easy installation
- Permits various fluid conductors to be mixed
- Resists most fuels, oil, gases, solvents

# CUSHION CLAMPS

Finish: Yellow Zinc Chromite, other materials and finishes available on request

## C-100 CUSHION CLAMPS FOR TUBE FEATURES

ORDERING: Specify Catalog Number

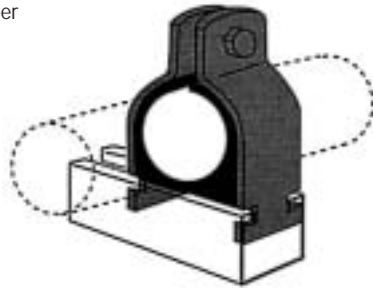

Cat.#	Tube O.D. Size	Steel Ga.	Wt. C. Pcs.	Std. Pkg
C100025	1/4"	14	11	24
C100037	3/8"	14	12	24
C100050	1/2"	14	13	24
C100062	5/8"	14	15	24
C100075	3/4"	14	19	24
C100087	7/8"	14	21	24
C100100	1"	12	25	12
C100112	1 1/8"	12	29	12
C100125	1 1/4"	12	29	12
C100137	1 3/8"	11	38	12
C100150	1 1/2"	11	38	12
C100162	1 5/8"	11	40	12
C100175	1 3/4"	11	42	Bulk
C100187	1 7/8"	11	46	Bulk
C100200	2"	11	46	Bulk
C100212	2 1/8"	11	58	Bulk
C100237	2 3/8"	11	58	Bulk
C100262	2 5/8"	12	58	Bulk
C100300	3"	12	69	Bulk
C100312	3 1/8"	12	59	Bulk
C100362	3 5/8"	11	75	Bulk
C100412	4 1/8"	11	90	Bulk

## C-200 CUSHION CLAMPS FOR PIPE

ORDERING: Specify Catalog Number

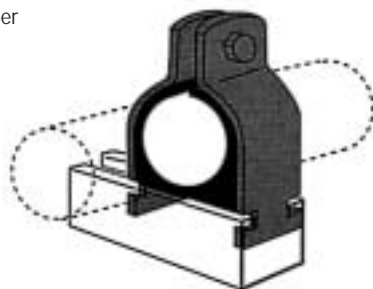

Cat.#	Nom. Pipe Size	Steel Ga.	Wt. C. Pcs.	Std. Pkg
C200025	1/4"	14	12	24
C200037	3/8"	14	14	24
C200050	1/2"	14	22	24
C200075	3/4"	12	58	12
C200100	1"	11	39	12
C200125	1 1/4"	11	43	12
C200150	1 1/2"	11	47	Bulk
C200200	2"	11	55	Bulk
C200250	2 1/2"	12	60	Bulk
C200300	3"	11	76	Bulk
C200350	3 1/2"	11	94	Bulk
C200400	4"	11	93	Bulk
C200500	5"	11	125	Bulk
C200600	6"	11	145	Bulk

# PIPE CLAMPS

## C-1100 EMT CLAMPS

FINISH: Electro-Galvanized, other finishes on application

ORDERING: Specify Figure Number and Pipe Size

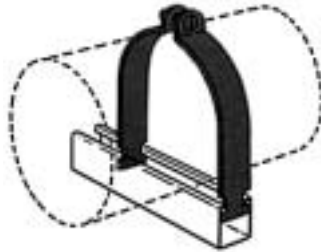

Nom. Comb. Size	O.D. Size	Steel GA.	Wt. C. Pcs.	Std. Pkg.
3/8"	0.577	16	9	100
1/2"	0.706	16	11	100
3/4"	0.922	16	12	100
1"	1.163	14	15	100
1 1/4"	1.510	14	18	100
1 1/2"	1.740	12	29	50
2"	2.197	12	33	50

## C-1102 RIGID CONDUIT CLAMPS

FINISH: Electro-Galvanized, other finishes on application

ORDERING: Specify Figure Number and Pipe Size

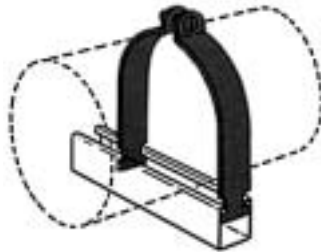

Pipe Size	O.D. Size	Steel GA.	Wt. C Pcs.	Std. Pkg.
3/8"	0.675	16	12	100
1/2"	0.140	16	13	100
3/4"	1.050	14	15	100
1"	1.315	14	18	100
1 1/4"	1.660	14	22	100
1 1/2"	1.900	12	32	50
2"	2.375	12	37	50
2 1/2"	2.875	12	42	50
3"	3.500	12	49	50
3 1/2"	4.000	11	65	40
4"	4.500	11	69	40
5"	5.563	11	82	20
6"	6.625	10	107	20
8"	8.625	10	133	Bulk
10"	10.75	10	143	Bulk

## C-1104 UNIVERSAL CLAMPS

FINISH: Electro-Galvanized, other finishes on application

ORDERING: Specify Figure Number and Pipe Size

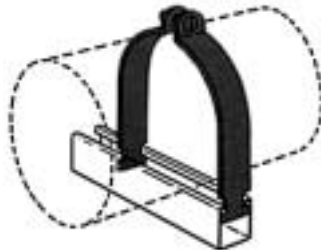

Nom. Size for E.M.T. Rigid Copper Clamps	O.D. Range Min./Max.	Wt. C PCs.	Sid. Pkg.
3/8"	.557 to .675	12	100
1/2"	.706 to .840	13	100
3/4"	.922 to 1.050	14	100
1"	1.163 to 1.315	18	100
1 1/4"	1.510 to 1.660	21	100
1 1/2"	1.740 to 1.900	23	50
2"	2.197 to 2.375	25	50

# PIPE CLAMPS

## C-1101 TUBING CLAMPS

FINISH: Electro-Galvanized (EZN)

ORDERING: Specify Figure Number  
and O.D. Size



O. D. Size	Tube Size	Steel Ga.	Wt. C.	Std. Pcs.	Pkg.	O. D. Size	Tube Size	Steel Ga.	Wt. C.	Std. Pcs.	Pkg.
1/4"	1/8"	16	8	100		4"	3 7/8"	11	61	25	
3/8"	1/4"	16	8	100		4 1/8"	4"	11	61	25	
1/2"	3/8"	16	8	100		4 1/4"	4 1/8"	11	64	25	
5/8"	1/2"	16	9	100		4 3/8"	4 1/4"	11	64	25	
3/4"	5/8"	16	11	100		4 1/2"	4 3/8"	11	66	25	
7/8"	3/4"	16	11	100		4 5/8"	4 1/2"	11	66	25	
1"	7/8"	14	13	100		4 3/4"	4 5/8"	11	68	25	
1 1/8"	1"	14	15	100		4 7/8"	4 3/4"	11	73	25	
1 1/4"	1 1/8"	14	16	100		5"	4 7/8"	11	74	25	
1 3/8"	1 1/4"	14	17	100		5 1/8"	5"	11	70	25	
1 1/2"	1 3/8"	14	18	100		5 1/4"	5 1/8"	11	70	25	
1 5/8"	1 1/2"	14	19	50		5 3/8"	5 1/4"	11	77	25	
1 3/4"	1 5/8"	12	19	50		5 1/2"	5 3/8"	11	78	25	
1 7/8"	1 3/4"	12	28	50		5 5/8"	5 1/2"	10	83	25	
2"	1 7/8"	12	31	100		5 3/4"	5 5/8"	10	94	25	
2 1/8"	2"	12	31	50		5 7/8"	5 3/4"	10	85	25	
2 1/4"	2 1/8"	12	33	50		6"	5 7/8"	10	94	20	
2 3/8"	2 1/4"	12	34	50		6 1/8"	6"	10	94	25	
2 1/2"	2 3/8"	12	35	50		6 1/4"	6 1/8"	10	96	25	
2 5/8"	2 1/2"	12	36	50		6 3/8"	6 1/4"	10	98	25	
2 3/4"	2 5/8"	12	37	50		6 1/2"	6 3/8"	10	99	25	
2 7/8"	2 3/4"	12	39	50		6 5/8"	6 1/2"	10	100	25	
3"	2 7/8"	12	41	50		6 3/4"	6 5/8"	10	102	25	
3 1/8"	3"	12	42	50		6 7/8"	6 3/4"	10	104	Bulk	
3 1/4"	3 1/8"	12	42	50		7"	6 7/8"	10	108	Bulk	
3 3/8"	3 1/4"	12	43	50		7 1/8"	7"	10	108	Bulk	
3 1/2"	3 3/8"	12	44	50		7 3/8"	7 1/4"	10	112	Bulk	
3 5/8"	3 1/2"	11	56	25		7 5/8"	7 1/2"	10	115	Bulk	
3 3/4"	3 5/8"	11	57	25		7 7/8"	7 3/4"	10	119	Bulk	
3 7/8"	3 3/4"	11	57	25		8"	7 7/8"	10	121	Bulk	

## C-1101 TUBING CLAMPS

FINISH: Cooper plated

ORDERING: Specify Figure Number  
and Tube Size

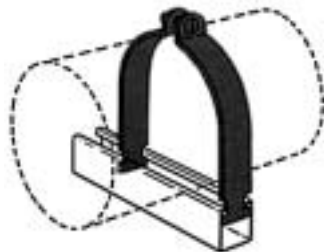

O. D. Size	Tube Size	Steel Ga.	Wt. C.	Std. Pcs.	Pkg.	O. D. Size	Tube Size	Steel Ga.	Wt. C.	Std. Pcs.	Pkg.
3/8"	1/4"	16	8	100		2 1/8"	2"	12	31	50	
1/2"	3/8"	16	8	100		2 5/8"	2 1/2"	12	36	50	
5/8"	1/2"	16	9	100		3 1/8"	3"	12	42	50	
3/4"	5/8"	16	11	100		3 5/8"	3 1/2"	12	56	50	
7/8"	3/4"	16	11	100		4 1/8"	4"	11	61	25	
1 1/8"	1"	16	13	100		5 1/8"	5"	11	16	25	
1 3/8"	1 1/4"	14	16	100		6 1/8"	6"	10	96	25	
1 5/8"	1 1/2"	14	19	50		8 1/8"	8"	10	125	Bulk	



# PIPE CLAMPS

## C1107 PARALLEL PIPE CLAMP

FINISH: Electro Galvanized (EZN)

ORDERING: Specify Figure Number  
and O.D. Size



Pipe Size	O.D. Size	Wt. C. Pcs.	Pipe Size	O.D. Size	Wt. C. Pcs.
3/8"	0.675	27	2"	2.375	47
1/2"	0.840	29	2 1/2"	2.875	66
3/4"	1.050	30	3"	3.500	78
1"	1.315	31	3 1/2"	4.000	87
1 1/4"	1.660	38	4"	4.500	90
1 1/2"	1.900	40			

## C1108 PIPE STRAPS

FINISH: Electro Galvanized (EZN)

ORDERING: Specify Figure Number  
and Pipe Size

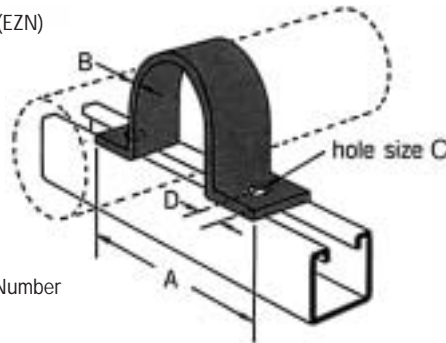

Nom. Pipe Size	A	B	C	D	Wt. C. Pcs.
1/2"	2 7/8"	1/8"	9/32"	7/16"	23
3/4"	3 1/16"	1/8"	9/32"	7/16"	26
1"	3 11/32"	1/8"	9/32"	7/16"	31
1 1/4"	3 11/16"	1/8"	9/32"	7/16"	35
1 1/2"	3 29/32"	1/8"	9/32"	7/16"	39
2"	5 21/32"	1/4"	13/32"	13/16"	94
2 1/2"	6 5/32"	1/4"	13/32"	13/16"	114
3"	6 25/32"	1/4"	13/32"	13/16"	133
3 1/2"	7 9/32"	1/4"	13/32"	13/16"	152
4"	7 25/32"	1/4"	13/32"	13/16"	176
5"	7 21/32"	1/4"	13/32"	13/16"	198
6"	9 29/32"	1/4"	13/32"	13/16"	246

## C1109 ONE HOLE TUBING CLAMP

Finish: Electro Galvanized (EZN)

ORDERING: Specify Figure Number  
and Pipe Size

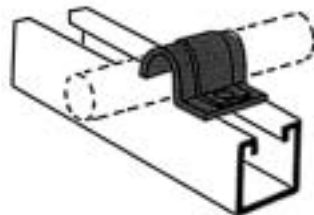

O. D. Size	Steel Ga.	Wt. C. Pcs.	Std. Pkg.
1/4"	16	4	100
5/16"	16	5	100
3/8"	16	5	100
1/2"	16	6	100
5/8"	14	8	100
3/4"	14	9	100
7/8"	14	10	50
1"	14	11	50

## SECTION IV GENERAL FITTINGS

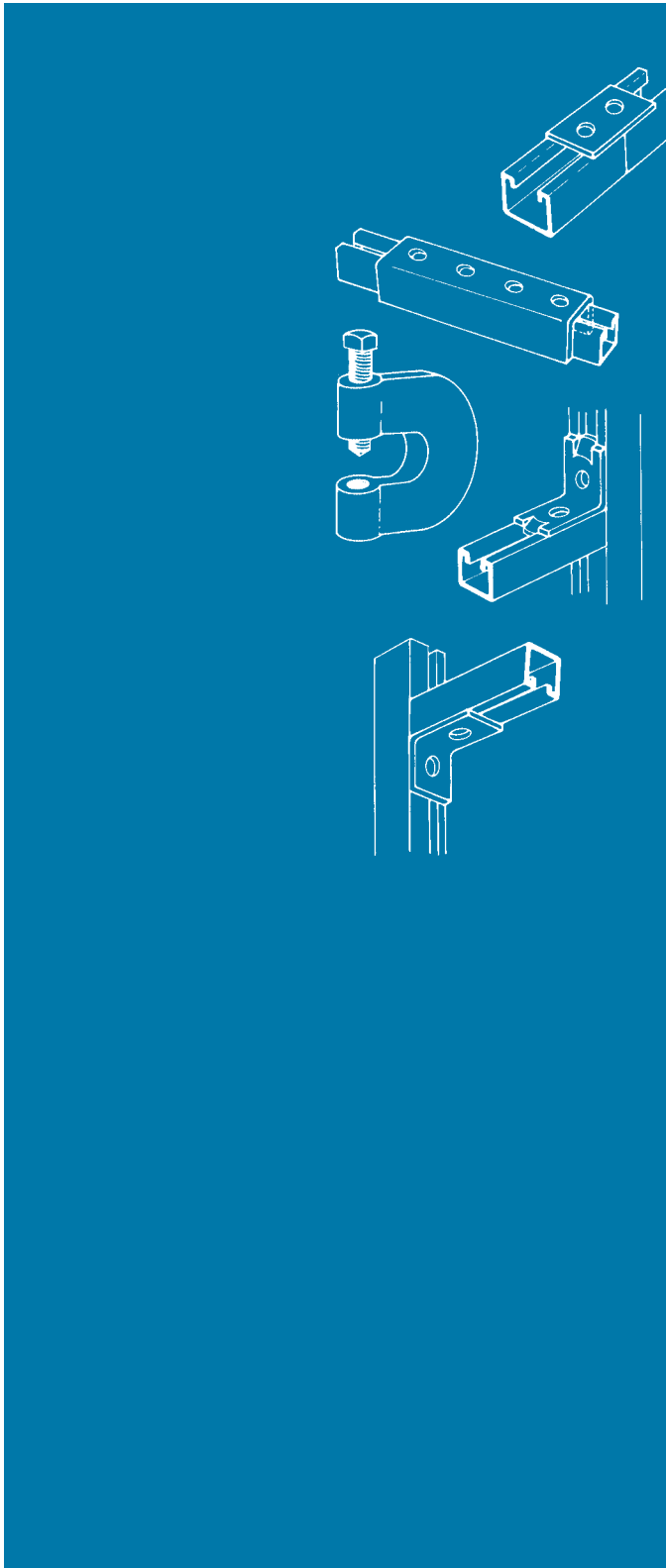

### SPECIFICATIONS

#### GENERAL

Multi-Strut general fittings are designed to fit with all Multi-Strut channels. The more popular fittings are illustrated on the following pages. These are the most commonly used and will cover most installation requirements. However, there are hundreds of other Multi-Strut fittings available for specific applications. If you have a special requirement, please contact our engineering department for recommendations.

#### MATERIAL

Multi-Strut fittings are manufactured from  $\frac{1}{4}$ " thick carbon steel. All fittings are  $1\frac{5}{8}$ " wide and all holes are  $\frac{9}{16}$ " in diameter, spaced  $1\frac{7}{8}$ " on centers and  $1\frac{3}{16}$ " from ends. All dimensions apply to all fittings except where noted.

#### FINISH

Multi-Strut fittings are stocked in electro-galvanized finish. Other finishes are available upon request.

#### ORDERING

Please specify catalog number, size and finish.

# FLAT PLATE

**DATA:**

1/4" thick, 1 5/8" wide, holes 9/16" dia., spaced 1 7/8" on center & 1 3/16" from end.

FINISH: Electro-Galvanized

**F-201**  
SQUARE  
WASHER

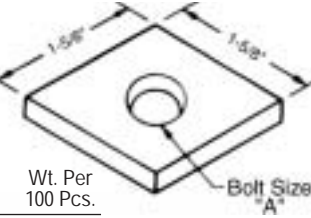

Cat. No.	A	Wt. Per 100 Pcs.
F-201	5/16"	18
F-201	3/8"	18
F-201	1/2"	17
F-201	5/8"	16
F-201	3/4"	15

**F-202**  
FLAT PLATE  
CONNECTOR

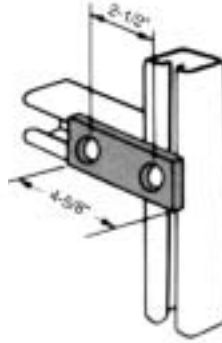

**F-203**  
TWO HOLE  
SPLICE  
PLATE

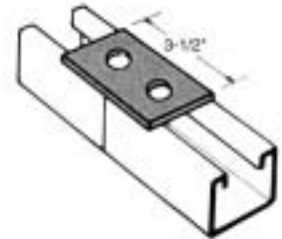

**F-205**  
FOUR HOLE  
SPLICE PLATE

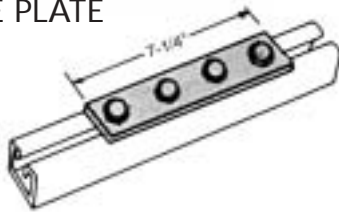

**F-206-1**  
THREE HOLE  
SPLICE  
PLATE

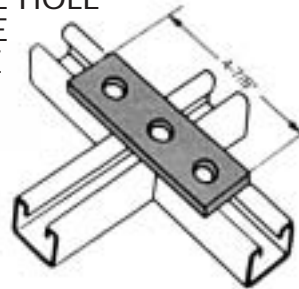

**F-206-2**  
THREE HOLE  
SPLICE  
PLATE

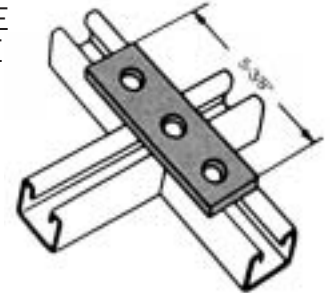

**F-207**  
THREE HOLE SWIVEL

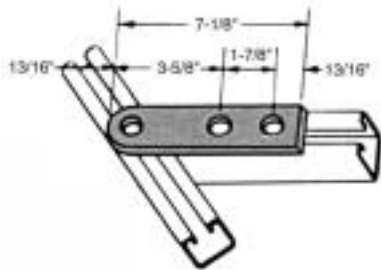

**F-210**  
THREE HOLE  
FLAT ANGLE  
PLATE

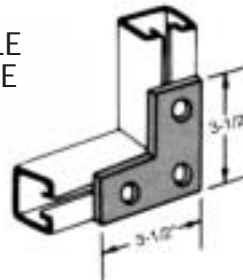

**F-212**  
THREE HOLE  
CONNECTION  
PLATE

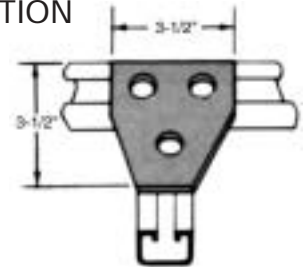

**F-213**  
FOUR HOLE  
TEE PLATE

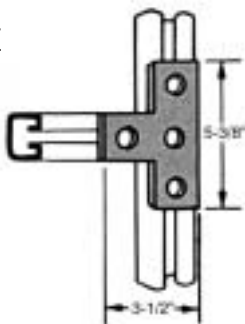

**F-214**  
FOUR HOLE  
CORNER  
JOINER  
PLATE

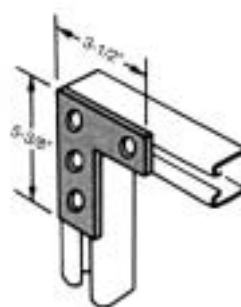

**F-216**  
CROSS  
PLATE

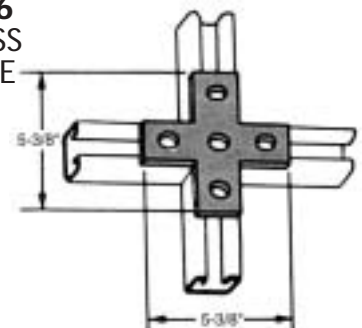

# FLAT PLATE

DATA:  
 1/4" thick, 1 5/8" wide, holes 3/16" dia.,  
 spaced 1 7/8" on center & 13/16" from end.

FINISH: Electro-Galvanized

**F-204**  
 SPLICE PLATE

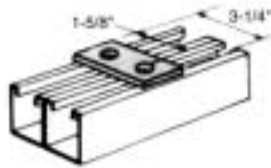

**F-211**  
 THREE HOLE CORNER  
 CONNECTOR

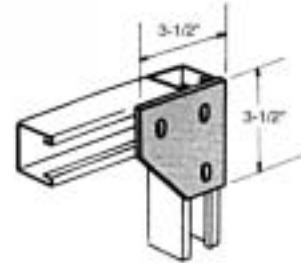

**F-217**  
 FOUR HOLE  
 CONNECTOR

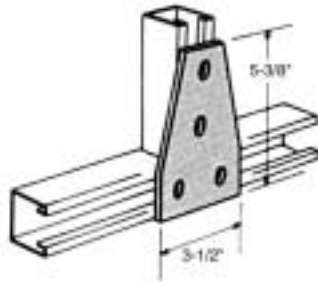

**F-218**  
 FOUR HOLE  
 CORNER CONNECTOR

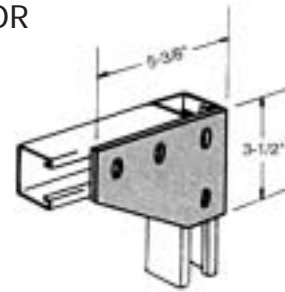

**F-219**  
 FIVE HOLE  
 CONNECTOR

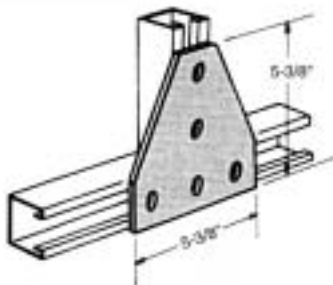

**F-220**  
 SEVEN HOLE  
 CONNECTOR

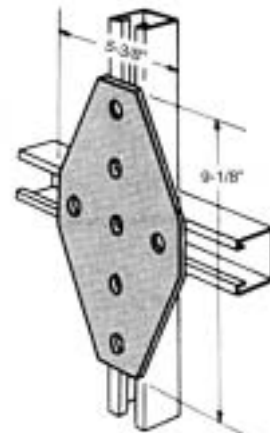

# ANGLE BRACKETS

DATA:  
 1/4" thick, 1 5/8" wide, holes 9/16" dia.,  
 spaced 1 7/8" on center & 1 3/16" from end.

FINISH: Electro-Galvanized

**A-301**  
 TWO HOLE  
 CORNER ANGLE

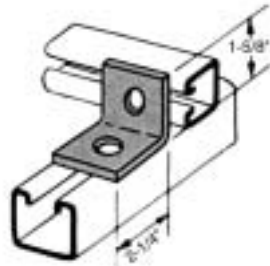

**A-302**  
 CONNECTION  
 ANGLE

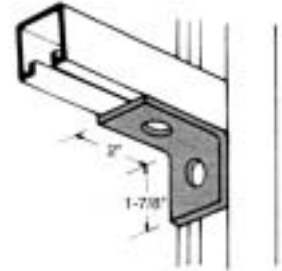

**A-303**  
 NO-TWIST  
 CORNER ANGLE  
 (1 indent)

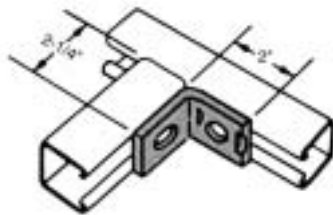

**A-304**  
 NO-TWIST  
 CORNER ANGLE  
 (2 indents)

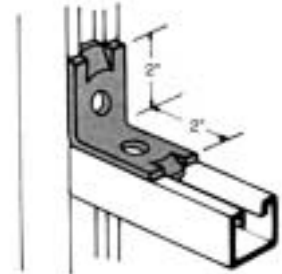

**A-305**  
 THREE HOLE 90°  
 BRACKET

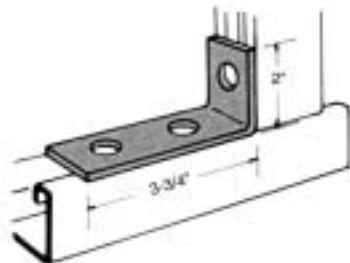

**A-306**  
 THREE HOLE CORNER  
 CONNECTOR

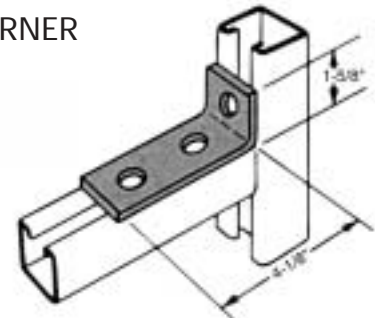

**A-309**  
 FOUR HOLE JOINT  
 CONNECTOR  
 ANGLE

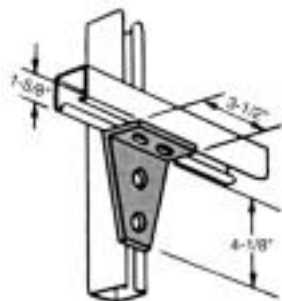

**A-310**  
 FOUR HOLE  
 DUPLEX CORNER  
 ANGLE

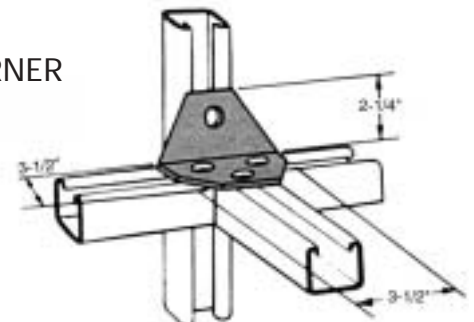

# ANGLE BRACKETS

DATA:  
 1/4" thick, 1 5/8" wide, holes 9/16" dia.,  
 spaced 1 7/8" on center & 1 3/16" from end.

FINISH: Electro-Galvanized

## A-336 SLOTTED ANGLE

Cat. No.	A	B
A-336	4 7/8"	2 1/2"
A-336-1	6 7/8"	4 1/2"

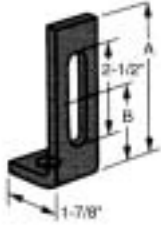

## A-337 SLOTTED ANGLE

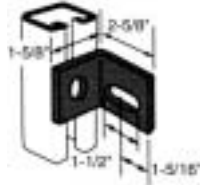

## A-338 TWO HOLE OFFSET ANGLE

Cat. No.	A
A-338-1	3"
A-338-2	3 1/2"
A-338-3	4"

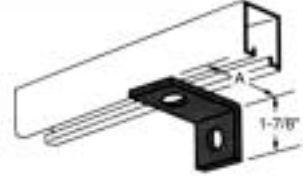

## A-316 ANGLE FITTING



## A-317 TWO HOLE CLOSED 45° ANGLE

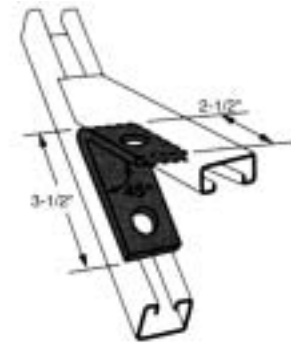

## A-319 ANGLE BRACKET

Cat. No.	A
A-319-1	82 1/2°
A-319-2	75°
A-319-3	67 1/2°
A-319-4	60°
A-319-5	52 1/2°
A-319-6	37 1/2°

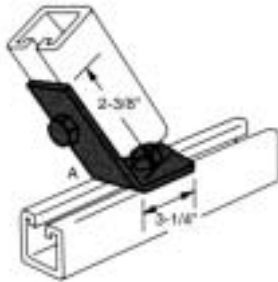

## A-320 OPEN ANGLE BRACKET

Cat. No.	A
A-320-1	30°
A-320-2	22 1/2°
A-320-3	15°
A-320-4	7 1/2°

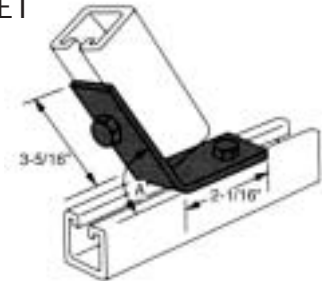

## A-3194 FOUR HOLE OPEN ANGLE BRACKET

Cat. No.	A
A-3194-1	7 1/2°
A-3194-2	15°
A-3194-3	22 1/2°
A-3194-4	30°
A-3194-5	37 1/2°
A-3194-6	45°
A-3194-7	52 1/2°
A-3194-8	60°
A-3194-9	67 1/2°
A-3194-10	75°
A-3194-11	82 1/2°



## A-3174 FOUR HOLE CLOSED ANGLE BRACKET

Cat. No.	A
A-3174-1	37 1/2°
A-3174-2	45°
A-3174-3	52 1/2°
A-3174-4	60°
A-3174-5	67 1/2°
A-3174-6	75°
A-3174-7	82 1/2°

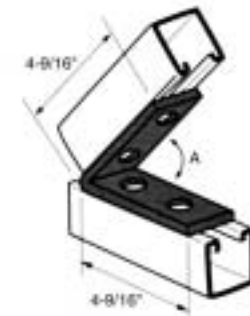

# ANGLE BRACKETS

**DATA:**

1/4" thick, 1 5/8" wide, holes 9/16" dia., spaced 1 7/8" on center & 1 3/16" from end.

FINISH: Electro-Galvanized

**A-311**  
FOUR HOLE ANGLE

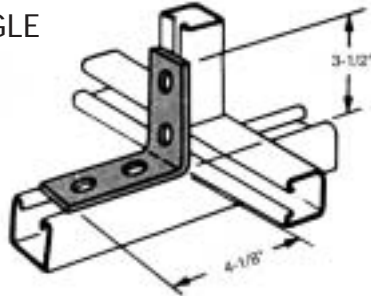

**A-313**  
FIVE HOLE DUPLEX  
CORNER ANGLE

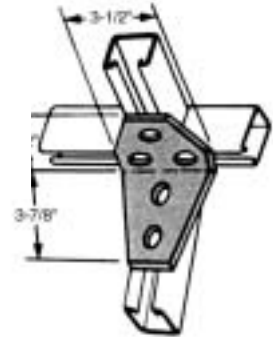

**A-318-L** (left hand)  
**A-318-R** (right hand)  
SHELF BRACKET  
(right hand illustrated)

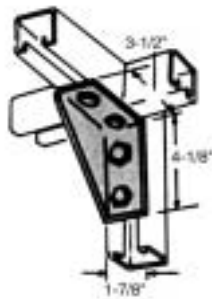

**A-335**  
UNIVERSAL SHELF  
BRACKET

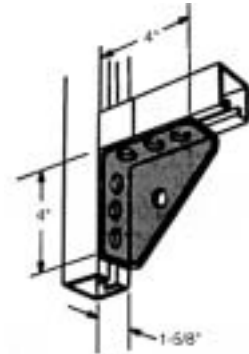

**A-312**  
FOUR HOLE 90°  
T-PLATE ANGLE

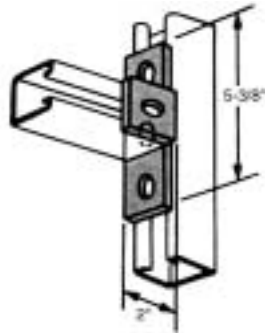

**A-330-L** (left hand)  
**A-330-R** (right hand)  
THREE HOLE  
90° ANGLE  
(left hand illustrated)

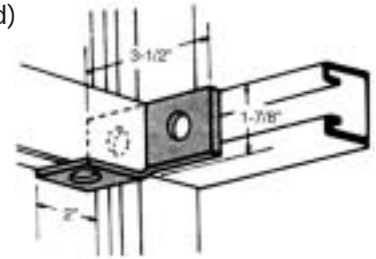

**A-314**  
FIVE HOLE JOINT  
CONNECTOR  
ANGLE

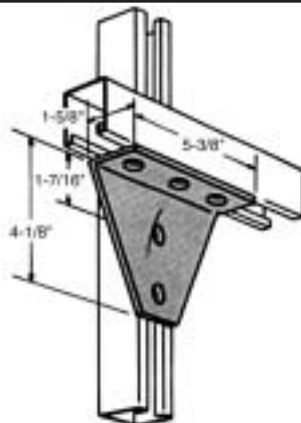

**A-315**  
**A-315-1**  
SLOTTED JOINT  
CONNECTOR  
ANGLE

Cat. No.	A	B
A-315	6 5/8"	4"
A-315-1	8 5/8"	6"

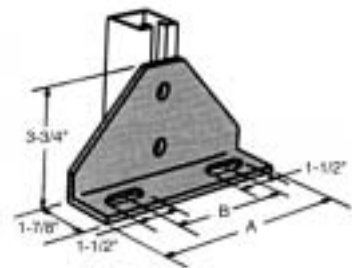

# "Z" ANGLE BRACKETS

DATA:  
 1/4" thick, 1 5/8" wide, holes 9/16" dia.,  
 spaced 1 7/8" on center & 1 3/16" from end.

FINISH: Electro-Galvanized

**A-322**  
 "Z" ANGLE

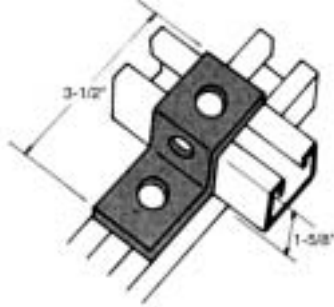

**A-323**  
 "Z" ANGLE

Cat. No.	A
A-323	1"
A-323-22	2 7/16"
A-323-42	1 3/8"
A-323-62	1 3/16"

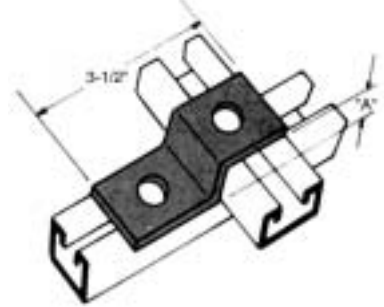

**A-324**  
 "Z" ANGLE

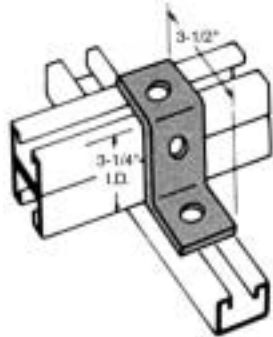

**A-325**  
 "Z" ANGLE OFFSET

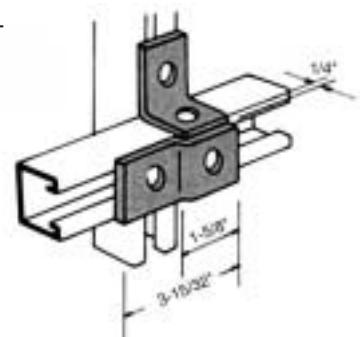

**A-340**  
 "Z" ANGLE

Cat. No.	A
A-340-1	4"
A-340-2	5"
A-340-3	6"
A-340-4	7"
A-340-5	8"

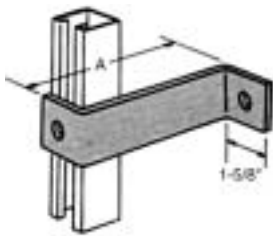

**A-341**  
 "Z" ANGLE

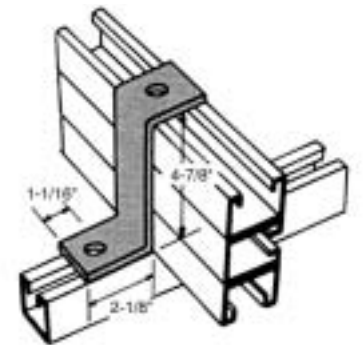



# WING FITTINGS

DATA:  
 1/4" thick, 1 5/8" wide, holes 1/16" dia.,  
 spaced 1 7/8" on center & 1 3/16" from end.

FINISH: Electro-Galvanized

**A-321-L** (left hand)  
**A-321-R** (right hand)  
 THREE HOLE SINGLE  
 ANGLE CONNECTOR  
 (left hand illustrated)

wt. -60#/C

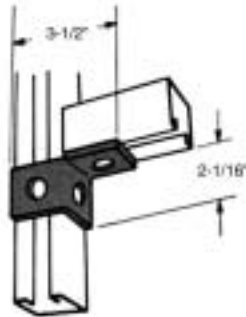

**A-321-1-L** (left hand)  
**A-321-1-R** (right hand)  
 SIX HOLE SINGLE  
 ANGLE CONNECTOR  
 (left hand illustrated)

wt. -119#/C

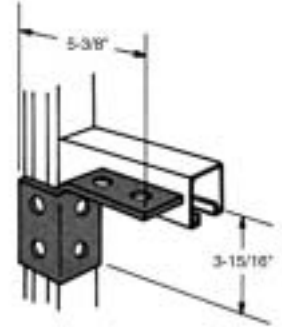

**A-326**  
 FOUR HOLE DOUBLE  
 ANGLE CONNECTOR

wt. -76#/C

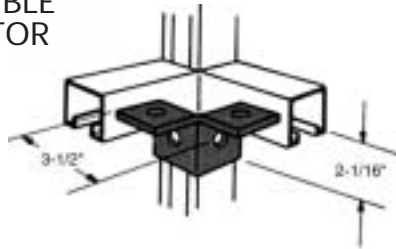

**A-326-1**  
 EIGHT HOLE DOUBLE  
 ANGLE CONNECTOR

wt. -155#/C

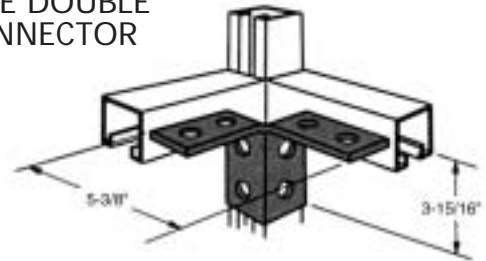

**A-327**  
 FIVE HOLE DOUBLE  
 ANGLE CONNECTOR

wt. -93#/C

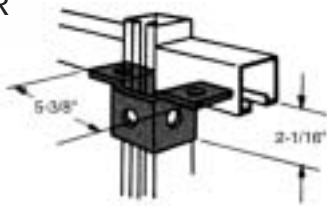

**A-327-1**  
 TEN HOLE DOUBLE  
 ANGLE CONNECTOR

wt. -193#/C

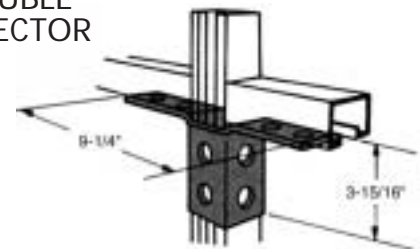

**A-328**  
 SIX HOLE TRIPLE  
 ANGLE CONNECTOR

wt. -113#/C

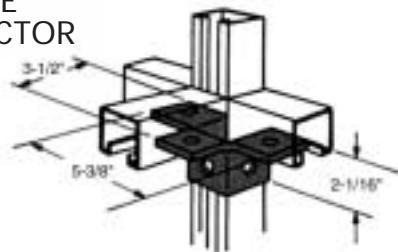

**A-328-1**  
 12-HOLE TRIPLE  
 ANGLE CONNECTOR

wt. -230#/C

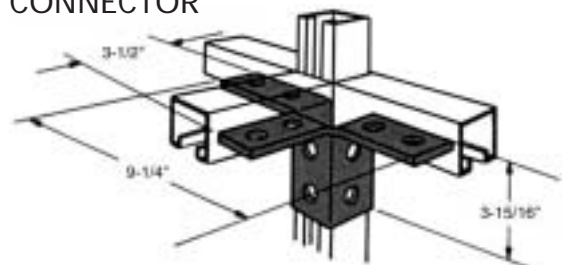

# FITTINGS

**DATA:**

1/4" thick, 1 5/8" wide, holes 9/16" dia., spaced 1 7/8" on center & 1 3/16" from end.

FINISH: Electro-Galvanized

**B-601**  
"U" SUPPORT

Cat. No.	A
B-601-1	1"
B-601-2	1 3/8"
B-601-3	1 5/8"
B-601-4	2 1/16"
B-601-5	2 3/4"
B-601-6	3 1/4"

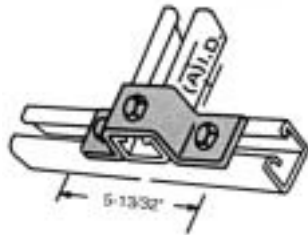

**B-602**  
"U" SUPPORT

Cat. No.	A	B
B-602-1	7 1/4"	4 1/8"
B-602-1	8 1/2"	5 3/8"
B-602-1	10 3/8"	7 1/4"

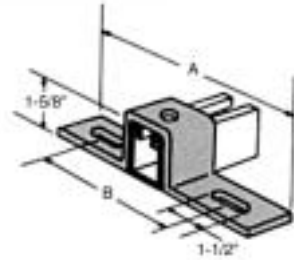

**B-601-7**  
"U" SUPPORT

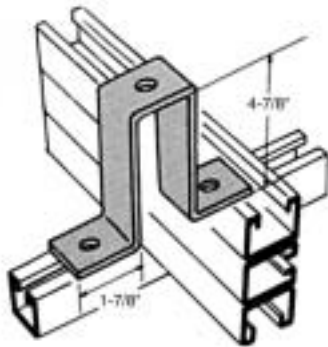

**B-610**  
"U" SUPPORT

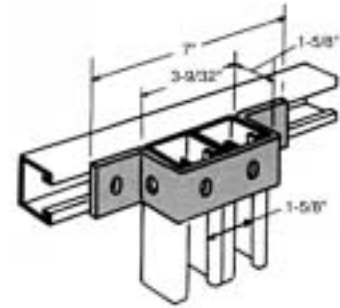

**B-611**  
"U" SUPPORT

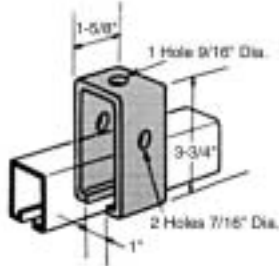

**B-612**  
"U" SUPPORT

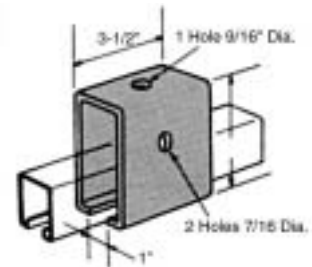

**B-613**  
"U" SUPPORT

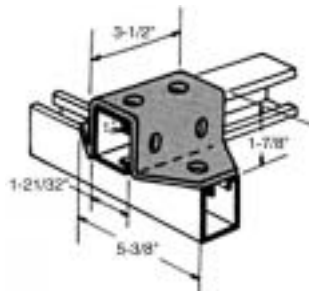

**B-614**  
"U" SUPPORT

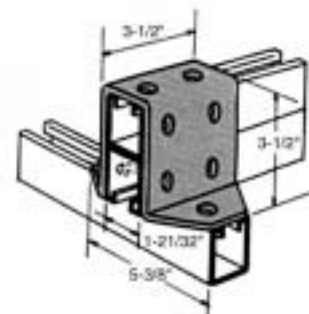

# FITTINGS

DATA:  
 1/4" thick, 1 5/8" wide, holes 3/16" dia.,  
 spaced 1 7/8" on center & 1 3/16" from end.

FINISH: Electro-Galvanized

**B-616**  
 "U" FITTING

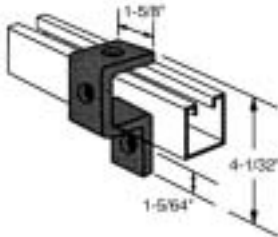

**B-615**  
 CLEVIS CONNECTOR

A	Wt. lbs./C
4"	78
5"	89
6"	101
7"	112
8"	124

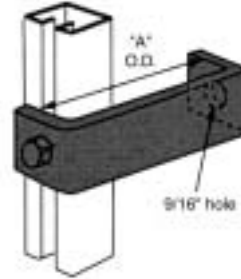

**B-605**  
 FOUR HOLE SPLICE CHANNEL

\* Use with M-132, M-134

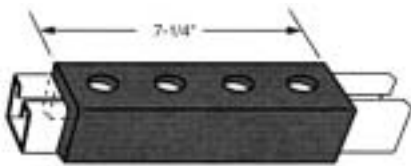

**B-606**  
 THREE HOLE SPLICE CHANNEL

\* Use with M-162, M-164, M-166

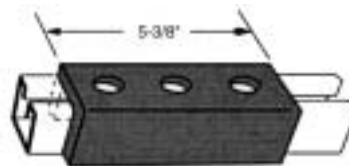

**B-607**  
 TWO HOLE SPLICE CHANNEL

\* Use with M-162, M-164, M-166

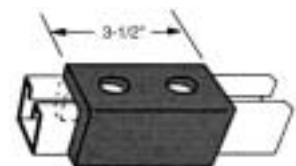

**B-604**  
 THREE HOLE SPLICE CHANNEL

\* Use with M-132, M-134

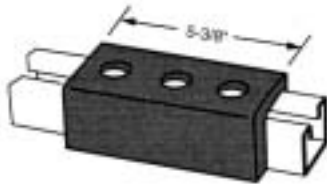

**B-608**  
 FOUR HOLE SPLICE CHANNEL

\* Use with M-162, M-164, M-166



**B-609**  
 TWO HOLE SPLICE CHANNEL

\* Use with M-132, M-134

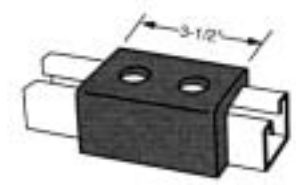

**B-603**  
 KNEE BRACE

Cat. No.	A	B
B-603-1	16 5/8"	13 5/8"
B-603-2	12"	10 1/8"

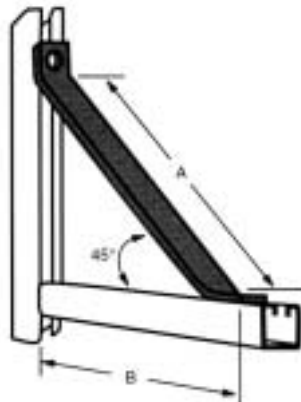

**B-620-FL-1**  
 SINGLE POST BASE

wt: 358#/C

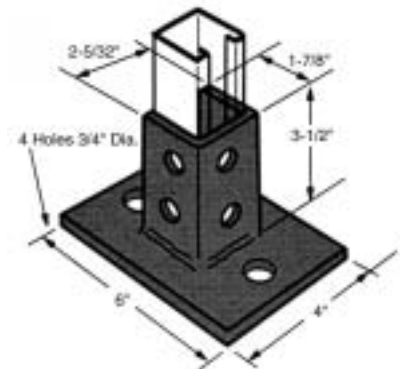

# FITTINGS

DATA:  
 1/4" thick, 1 5/8" wide, holes 9/16" dia.,  
 spaced 1 7/8" on center & 1 3/16" from end.

FINISH: Electro-Galvanized

**B-619A-SQ**  
 DOUBLE POST  
 BASE

wt: 330#/C

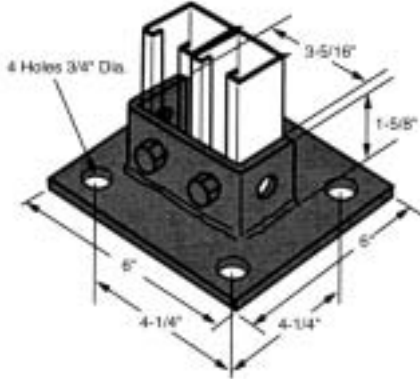

**B-619-SQ**  
 SINGLE POST  
 BASE

wt: 314#/C

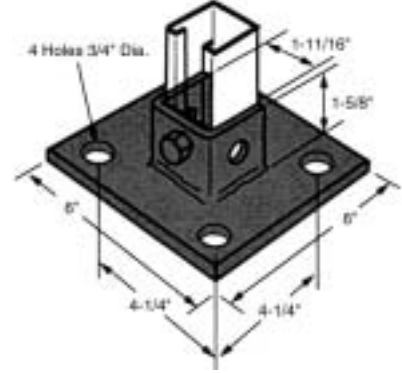

**B-619A-FL**  
 DOUBLE POST  
 BASE

wt: 250#/C

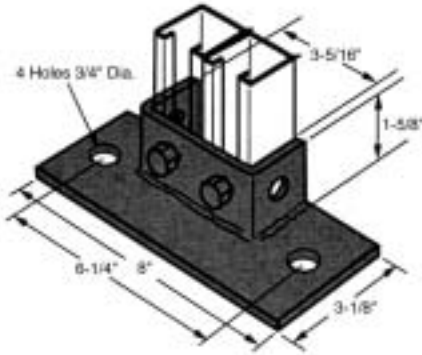

**B-619-FL**  
 SINGLE POST  
 BASE

wt: 230#/C

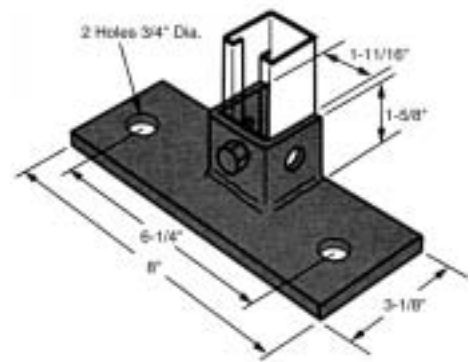

**B-619A**  
 DOUBLE POST  
 BASE

wt: 325#/C

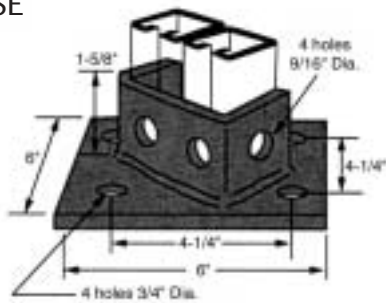

**B-619**  
 SINGLE POST  
 BASE

wt: 370#/C

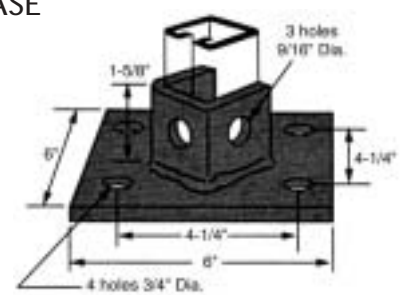

# FITTINGS

DATA:  
 1/4" thick, 1 5/8" wide, holes 9/16" dia.,  
 spaced 1 7/8" on center & 1 3/16" from end.

FINISH: Electro-Galvanized

**B-620**  
 SINGLE POST BASE

wt: 373#/C

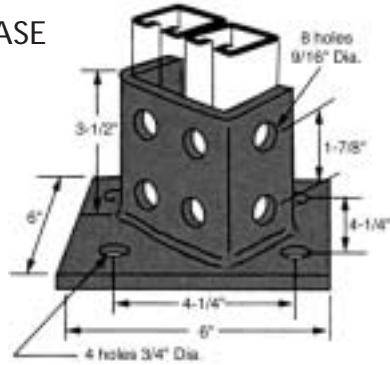

**B-620-A**  
 DOUBLE POST BASE

wt: 408#/C

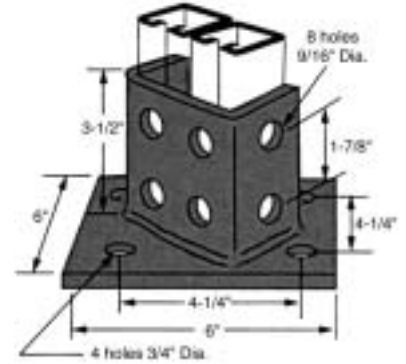

**B-620-SQ**  
 SINGLE POST BASE

wt: 392#/C

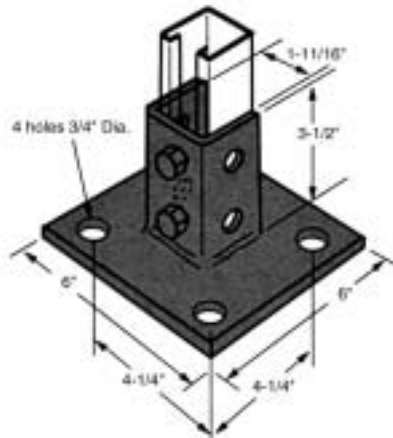

**B-620A-SQ**  
 DOUBLE POST BASE

wt: 400#/C

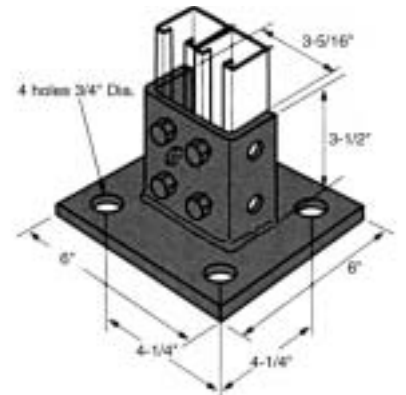

**B-620-FL**  
 SINGLE POST BASE

wt: 312#/C

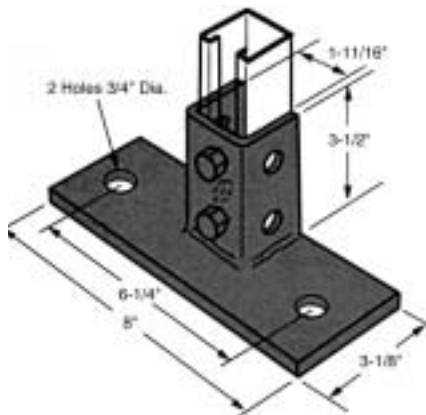

**B-620A-FL**  
 DOUBLE POST BASE

wt: 320#/C

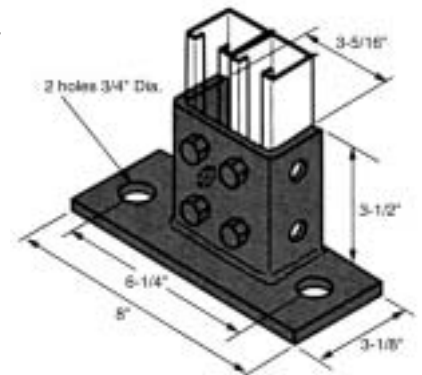

# BEAM CLAMPS

DATA:  
 1/4" thick, 1 5/8" wide, holes 3/16" dia.,  
 spaced 1 7/8" on center & 1 3/16" from end.

FINISH: Electro-Galvanized

**C-401**  
BEAM CLAMP

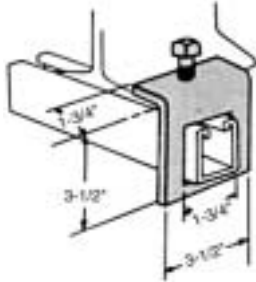

**C-402**  
BEAM CLAMP

Cat. No.	A
C-402-132	3 3/8"
C-402-122	5"

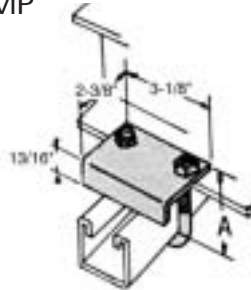

**C-403**  
BEAM CLAMP

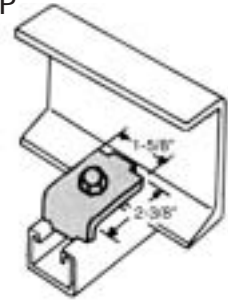

**C-404**  
BEAM CLAMP

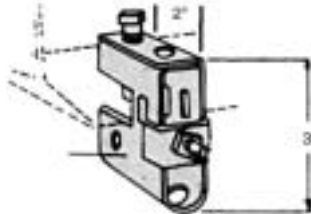

**C-405**  
STEEL BEAM CLAMP

Cat. No.	A
C-405-1	3/8"
C-405-2	1/2"

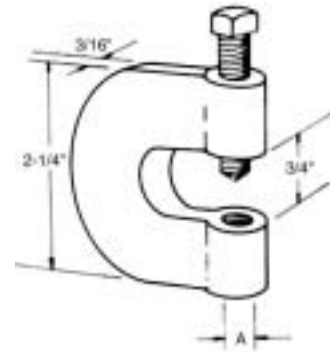

**C-406**  
BEAM CLAMP

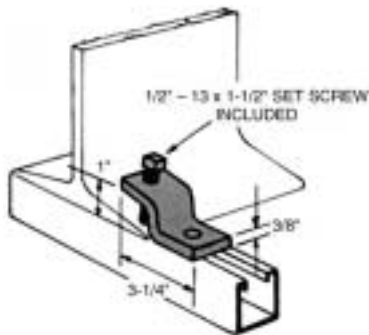

**C-407**  
BEAM CLAMP

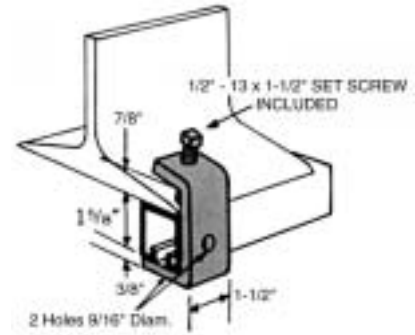

**C-408**  
BEAM CLAMP

Cat. No.	A	Flange Thickness	D (Set Screw Included)
C-408-1	1/4"	Up to 3/4"	3/8"-16 x 1 1/2"
C-408-2	3/8"	Up to 3/4"	1/2"-13 x 1 1/2"

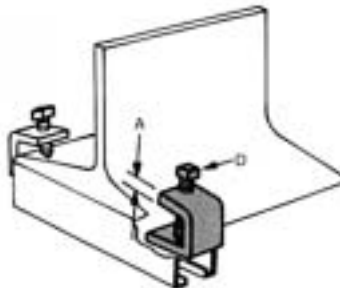

# BEAM CLAMPS

**DATA:**

1/4" thick, 1 5/8" wide, holes 9/16" dia., spaced 1 7/8" on center & 1 3/16" from end.

FINISH: Electro-Galvanized

## C-410 BEAM CLAMP

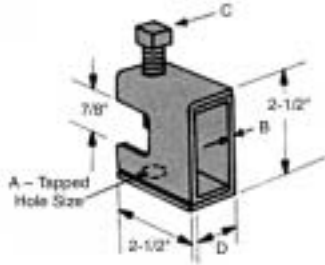

Cat. No.	A	B	C	D	Wt. Lbs./C
C-410-1	1/4"-20	1/8"	3/8" x 1 1/2"	7/8"	67
C-410-2	5/16" - 18	1/8"	3/8" x 1 1/2"	7/8"	67
C-410-3	3/8" - 16	1/8"	3/8" x 1 1/2"	7/8"	67
C-410-4	3/8" - 16	3/16"	1/2" x 1 1/2"	1 5/16"	100
C-410-5	1/2" - 13	3/16"	1/2" x 1 1/2"	1 5/16"	100
C-410-6	1/2" - 13	1/4"	1/2" x 1 1/2"	1 5/16"	130
C-410-7	5/8" - 11	1/4"	1/2" x 1 1/2"	1 5/16"	130
C-410-8	5/8" - 11	5/16"	5/8" x 1 1/2"	1 15/16"	160
C-410-9	3/4" - 10	5/16"	5/8" x 1 1/2"	1 15/16"	160

FOR BEAMS UNDER 1/8" THICK FLANGE.

## C-411 BEAM CLAMP

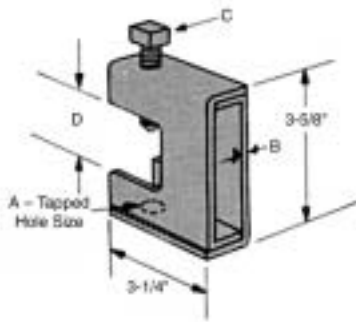

Cat. No.	A	B	C	D	Wt. Lbs./C
C-411-1	1/4" - 20	1/8"	3/8" x 2"	1 21/32"	109
C-411-2	3/8" - 16	3/16"	1/2" x 2"	1 11/16"	156
C-411-3	1/2" - 13	1/4"	1/2" x 2"	1 11/16"	201

FOR BEAMS BETWEEN 3/4" TO 1 5/8" THICK FLANGES.

## C-412 COLUMN BEAM CLAMP

- Note:  
 1. Use only with M-132,  
 M-134  
 2. Sold only in pairs

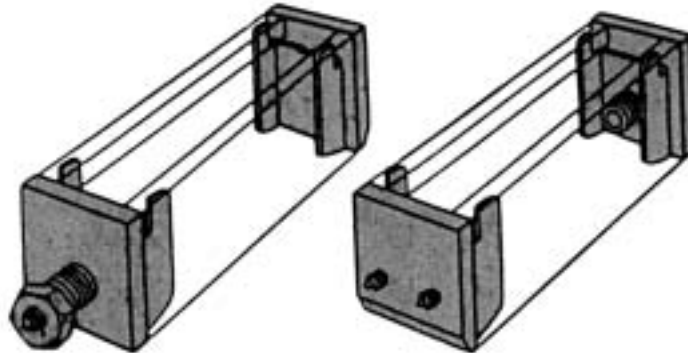

# MISCELLANEOUS FITTINGS

**DATA:**

1/4" thick, 1 5/8" wide, holes 9/16" dia., spaced 1 7/8" on center & 1 3/16" from end.

FINISH: Electro-Galvanized

**M-601**  
37 1/2° STAIR  
SUPPORT

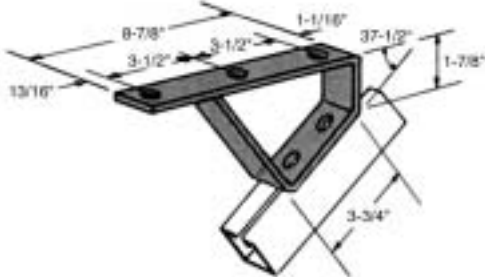

**M-602**  
45° STAIR  
SUPPORT

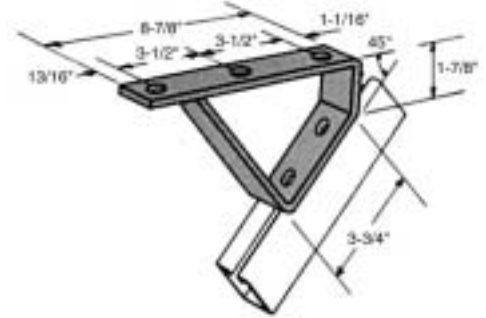

**M-610**  
LADDER RUNG

Cat. No.	A
M-610-1	12"
M-610-2	15"
M-610-3	18"

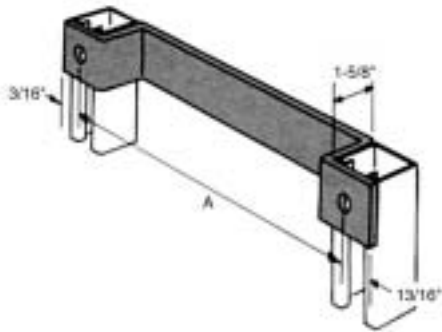

**M-611**  
WALL BRACKET

Cat. No.	A	B
M-611-1	2 3/8"	6"
M-611-2	4 3/8"	8"
M-611-3	6 3/8"	10"
M-611-4	8 3/8"	12"
M-611-5	10 3/8"	14"

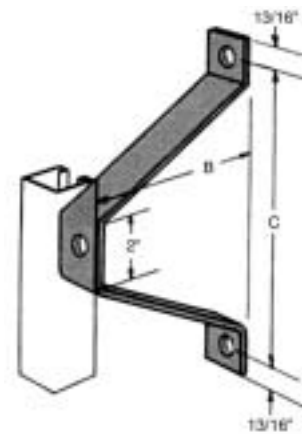

**M-605 L/R**  
[ITEM NAME?]

Cat. No.	A	B
M-605-1-L	3"	1 1/4"
M-605-1-R	3"	1 1/4"
M-605-2-L	3 5/8"	2"
M-605-3-R	3 5/8"	2"

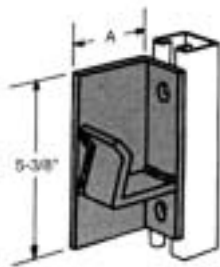



## SECTION V ELECTRICAL ACCESSORIES

---

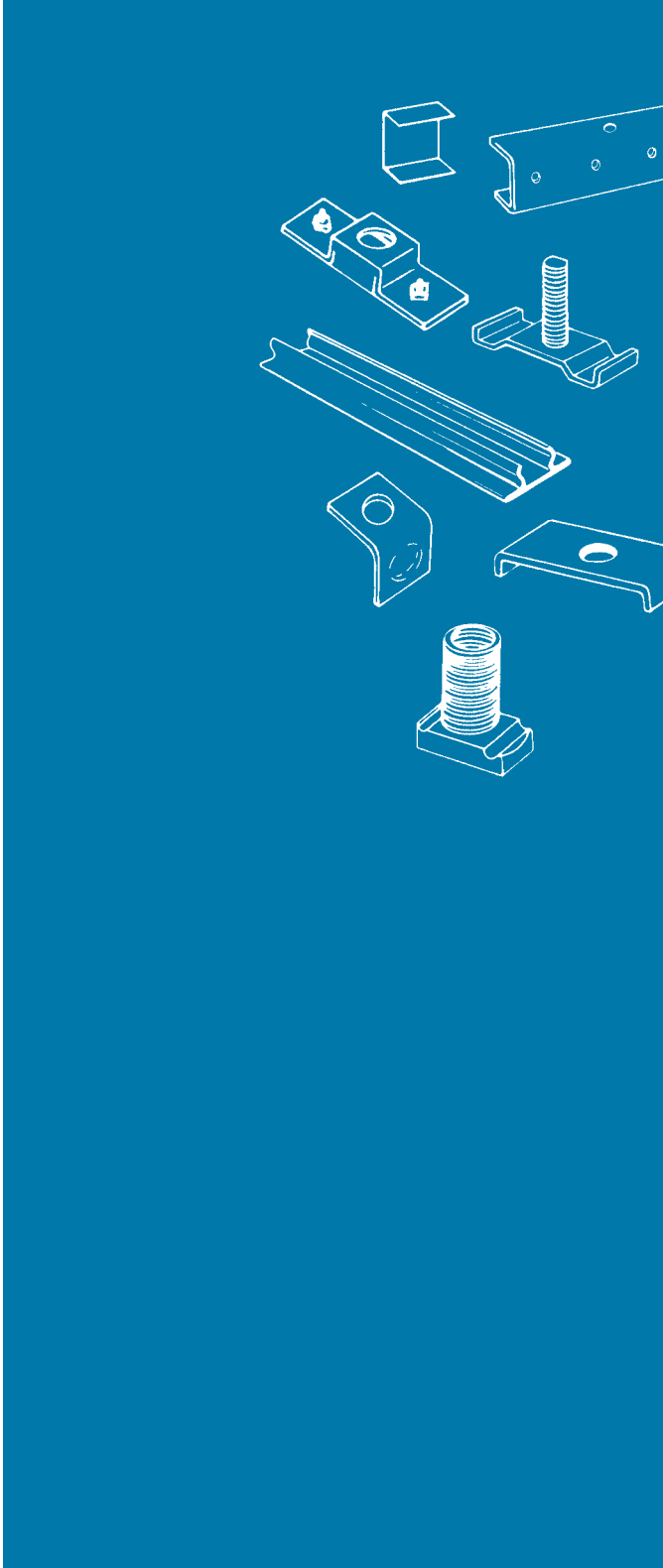

### SPECIFICATIONS

#### GENERAL

Multi-Strut closure strips are designed to fit all Multi-Strut channels to make a surface raceway. Electrical fittings are also designed to fit all channels.

#### MATERIAL

Multi-Strut closure strips and electrical fittings are produced from prime steel.

#### FINISH

Multi-Strut closure strips are stocked in both pre-galvanized and plain steel finish. Electrical fittings are electro-galvanized unless otherwise noted.

#### LENGTH

Multi-Strut closure strips are stocked in 10 foot lengths. Other lengths are available upon request.

#### ORDERING

Please specify catalog number, size, finish and length where applicable.

# ELECTRICAL ACCESSORIES

## SURFACE METAL RACEWAYS

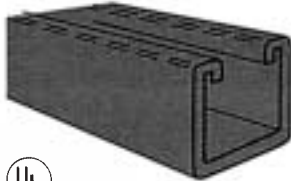

STANDARD

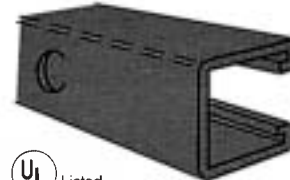

KNOCKOUT

Use of any standard or knockout channel with the C900 closure strip can be used as surface raceway as listed in chart below in accordance with Underwriters Laboratories

RJBT May 19, 1982  
**Surface Metal Raceways**

**E66743 (M)**

The following shows the maximum number of rubber or thermoplastic insulated conductors when the raceway is not employed with fixtures:

Multi-Strut Raceway No.	Wire Size Awg				
	14GA.	12GA.	10GA.	8GA.	6GA.
M-122	38	30	26	16	10
M-132	24	20	17	10	6
M-134	24	20	17	10	6
M-142	19	16	13	8	5
M-162	11	9	7	4	3
M-164	11	9	7	4	3
M-165	11	9	7	4	3

The suffix letters KO may be used to indicate raceway lengths with knockouts.

**LOOK FOR LISTING MARK ON PRODUCT**

304662001 H0760

**Underwriters Laboratories Inc.®**

F11/0053083

# ELECTRICAL ACCESSORIES

## C-900 CLOSURE STRIP

FINISH: Plain or Hot Dip Pre-Galvanized.  
 Figure C-900 closure strip is used as a cover plate for enclosing Multi-Strut channels. It is inserted before or after installation.  
 The closure strip fits all Multi-Strut channels and is available in standard 10 foot lengths. Other lengths are available upon request.  
 WT/C Ft. 47 Lbs.

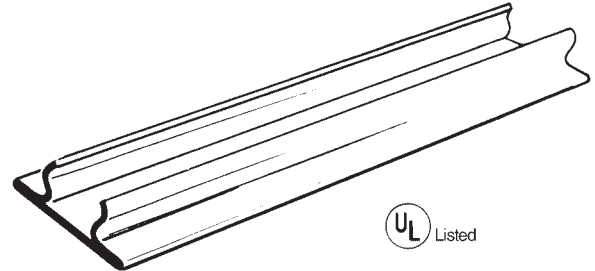
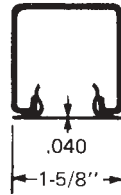

## E-501 1/2" OR 3/4" CONDUIT CONNECTOR PLATE

FINISH: Electro-Galvanized

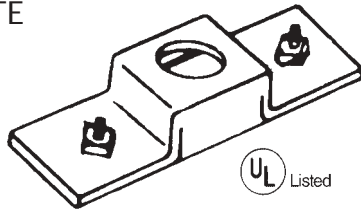

## E-502 ALUMINUM WIRE STUD 1/2"

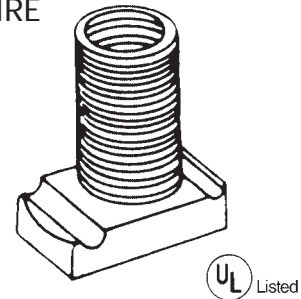

## E-513 THREE KNOCK-OUT PLATE

KO's for 1/2" conduit

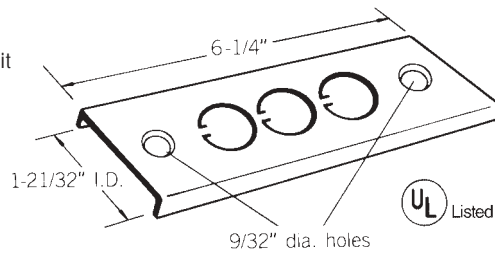

## E-503-SN FIXTURE NUT STUD 1/4" - 20 thd. x 1 1/4" long

FINISH: Electro-Galvanized

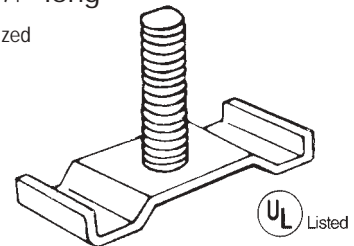

## E-503 FLOURESCENT FIXTURE NUT

Tapped for 1/4" - 20 thd.

FINISH: Electro-Galvanized

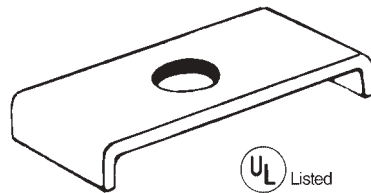

# ELECTRICAL ACCESSORIES

## E-504 CONDUIT END CAP

FINISH: Electro-Galvanized.  
Available 1/2" or 3/4" KO

Cat. No.	For Use With
E-504-1	M-122
E-504-2	M-132
E-504-3	M-142

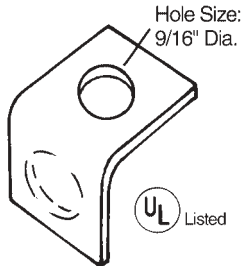

UL Listed

## E-505 SNAP TYPE FLOURESCENT FIXTURE HANGER

FINISH: Electro-Galvanized

Cat. No.	Use With Multi-Strut
E-505	M-132, M-134, M-142, M-152
E-505H	M-122

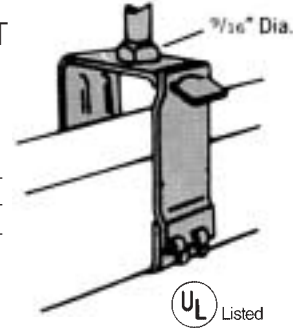

UL Listed

## E-510 FOUR HOLE SPLICE CLEVIS

FINISH: Electro-Galvanized  
Includes splice clip only on E510-2  
hardware not included

Cat. No.	For Use With
E-510-1	M-122
E-510-2	M-132, M-134
E-510-3	M-142
E-510-4	M-152
E-510-5	M-162, M-165

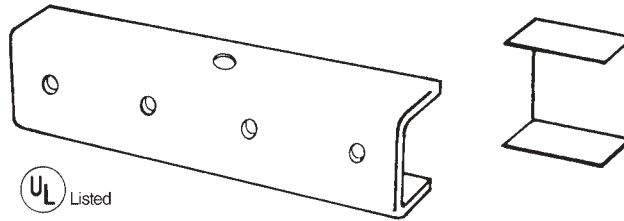

UL Listed

## E-511 STUD PLATE

FINISH: Electro-Galvanized  
Nuts not included

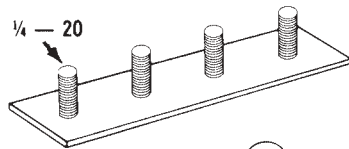

UL Listed

## E-512 TAPPED PLATE

FINISH: Electro-Galvanized  
Bolts not included

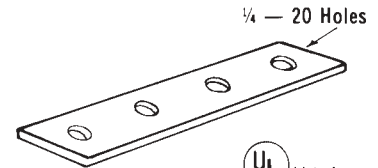

UL Listed

# SECTION VI CONCRETE INSERTS & ACCESSORIES



## SPECIFICATIONS

### GENERAL

Multi-Strut concrete inserts are designed for the attachment or suspension of framing, piping or equipment to concrete structures where a continuous insert slot is required. Continuous concrete inserts are nailed to the forms through the knockout holes provided in the closure cap (see illustration on next page). Nails may be cut off after removal of the forms.

### MATERIAL

Multi-Strut concrete inserts are produced from prime steel covering the following specifications:  
HOT DIPPED PRE-GALVANIZED .....ASTM A653  
HOT ROLLED STEEL .....ASTM A570

### FINISH

Multi-Strut concrete inserts are stocked in both plain and pre-galvanized finishes. Multi-Strut concrete accessories are stocked in electro-galvanized finish.

### LENGTH INFORMATION

Multi-Strut concrete inserts are produced and stocked in 10 and 20 foot lengths. Other lengths are available upon request.

### ORDERING

Please specify catalog number, size, finish and length where applicable.

# CONCRETE INSERTS

Multi-Strut Concrete inserts are supplied with the 1000 series End Caps and a strip inserted into the channel to prevent any concrete seepage. The foam is readily removable.

\*Other size channels available in concrete inserts upon request.

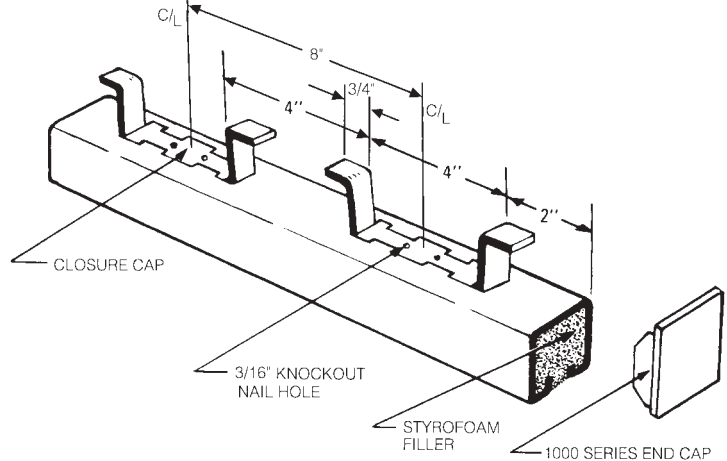

## M-142-IN CONCRETE INSERT

Channel:  $1\frac{3}{8}$ " x  $1\frac{5}{8}$ " x  $1\frac{3}{8}$ "  
 12 Ga. Wt/100'-188#  
 Stocked in Pre-Galvanized & Plain in 10' & 20' lengths.

\*Other lengths available

LOAD DATA: 1,800# in each 12" of Length

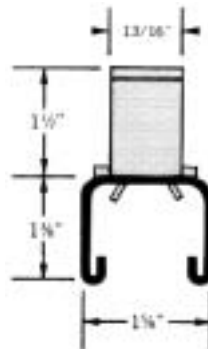

NOTE:

1. Safety Factor of 3
2. The above loading data was calculated in a concrete mixture which was proportioned so that the compression strength of the concrete was 2,500 to 3,000 pounds per square inch and that the load is dependent on the surrounding concrete.
3. Tests were performed in accordance with "The Metal Framing Manufacturers Association" 1983 specifications.

## M-152-IN CONCRETE INSERT

Channel: 1" x  $1\frac{5}{8}$ " x 1"  
 12 Ga. Wt/100'-162#  
 Stocked in Pre-Galvanized & Plain in 10' & 20' lengths.

\*Other lengths available

LOAD DATA: 1,700# in each 12" of Length



NOTE:

1. Safety Factor of 3
2. The above loading data was calculated in a concrete mixture which was proportioned so that the compression strength of the concrete was 2,500 to 3,000 pounds per square inch and that the load is dependent on the surrounding concrete.
3. Tests were performed in accordance with "The Metal Framing Manufacturers Association" 1983 specifications.

## M-164-IN CONCRETE INSERT

Channel:  $1\frac{3}{16}$ " x  $1\frac{5}{8}$ " x  $1\frac{3}{16}$ "  
 14 Ga. Wt/100'-121#  
 Stocked in Pre-Galvanized & Plain in 10' & 20' lengths.

\*Other lengths available

LOAD DATA: 1,700# in each 12" of Length

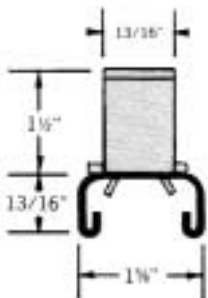

NOTE:

1. Safety Factor of 3
2. The above loading data was calculated in a concrete mixture which was proportioned so that the compression strength of the concrete was 2,500 to 3,000 pounds per square inch and that the load is dependent on the surrounding concrete.
3. Tests were performed in accordance with "The Metal Framing Manufacturers Association" 1983 specifications.

# PIPE CLAMPS

## 1001 SERIES END CAP

The 1001 Series-Anchor End Cap is furnished on all Inserts up to 12" in length and provides nail lugs at each end of the Insert. End Caps may be ordered separately

FINISH: Electro-Galvanized

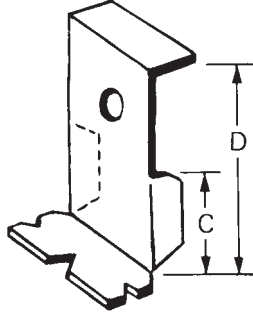

Fig. No.	Use With M-Strut	"C"	"D"
1001-EC-1	M-132	1.415	3 1/8"
1001-EC-2	M-142	1.165	2 7/8"
1001-EC-3	M-152	.790	2 1/2"

## 1000 SERIES END CAP

The 1000 Series Standard End Cap is supplied on all Concrete Inserts longer than 12". End Caps may be ordered separately

FINISH: Electro-Galvanized

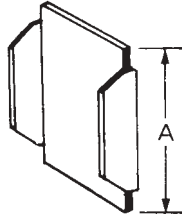
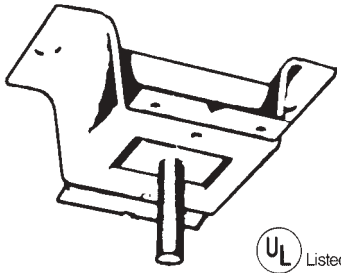

Fig. No.	Use With M-Strut	"C"
1000-EC-1	M-132	1 5/8"
1000-EC-2	M-142	1 3/8"
1000-EC-3	M-152	1"
1000-EC-5	M-164	1 3/16"
1000-EC-6	M-122	2 3/8"
1000-EC-7	M-112	3 7/32"
1000-EC-8	M-134	1 5/8"

## M-1200 SPOT INSERT

Designed to be used with N 1200 series spot insert nuts, a 7/8" x 1 5/8" knock-out is removed after concrete pour. The spot insert nut is placed in the slot, and then the rod screwed into the nut. The nut is secured in place by turning the rod. Lateral adjustment is made by loosening the nut and relocating.

FINISH: Electro-Galvanized



## N-1200 SQUARE NUT FOR SPOT INSERT

Nut must be placed in the spot insert before the rod can be screwed into the nut.

FINISH: Electro-Galvanized

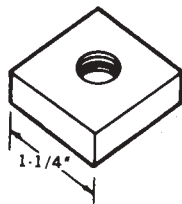
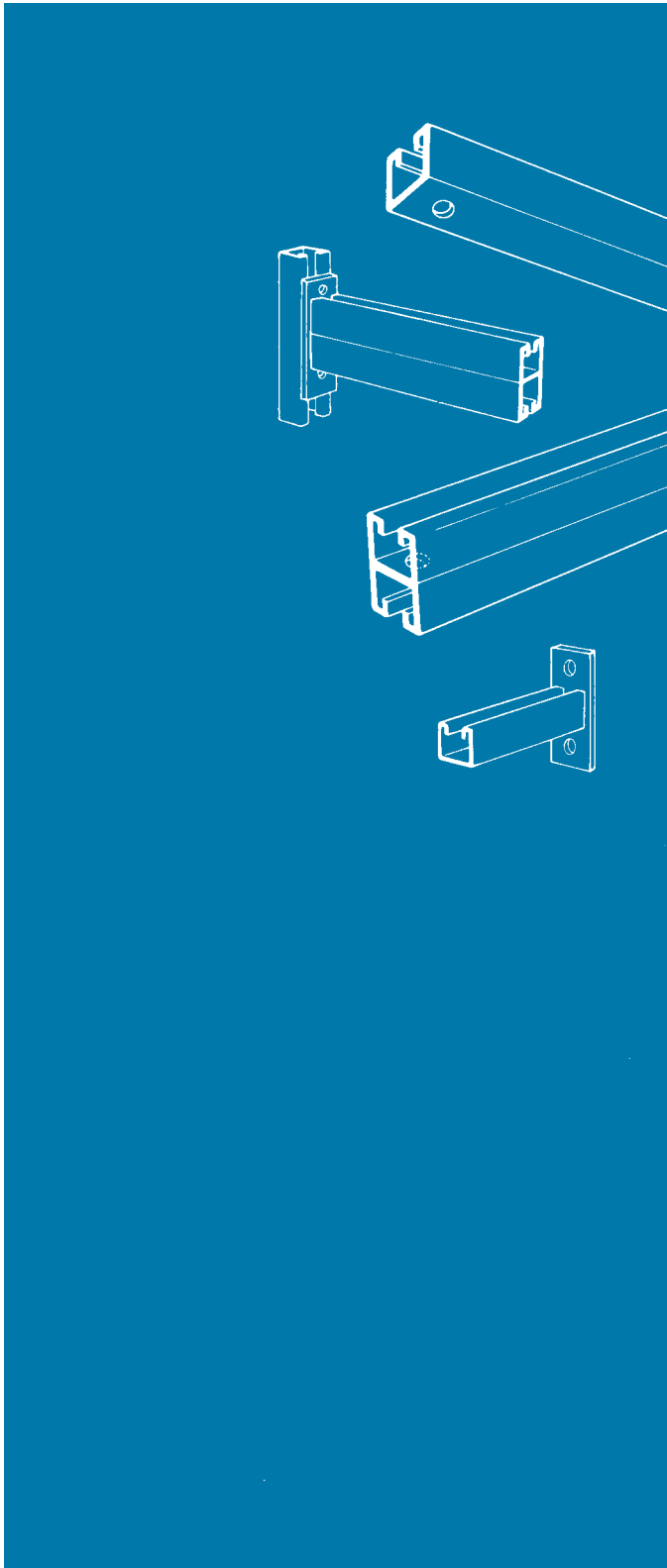

Fig. No.	Tapped Size
N-1200-1/4	1/4-20
N-1200-3/8	3/8-16
N-1200-1/2	1/2-13
N-1200-5/8	5/8-11
N-1200-3/4	3/4-10
N-1200-7/8	7/8-9

## SECTION VII TRAPEZES & BRACKETS

---



### SPECIFICATIONS

#### GENERAL

Multi-Strut trapezes and brackets are designed for the purpose of supporting pipe or conduit either suspended from threaded rod or supported as a cantilever from the wall.

#### MATERIAL

Multi-Strut trapezes and brackets are produced from standard channels. All hole dimensions are  $\frac{9}{16}$ " diameter and are located on the trapezes 1" from the end. Holes are located  $1\frac{3}{16}$ " from the end and  $1\frac{7}{8}$ " on center for the bracket.

#### FINISH

Multi-Strut trapezes and brackets are available in both plain and pre-galvanized finishes. Other finishes are available upon request.

#### ORDERING

Please specify catalog number, size, finish and length where applicable.



# TRAPEZES & BRACKETS

## SINGLE TRAPEZE

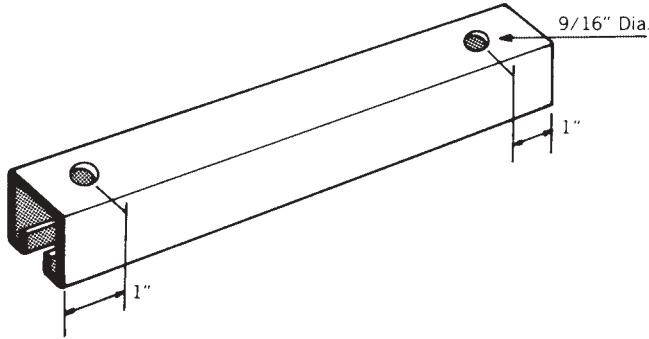

## DOUBLE TRAPEZE

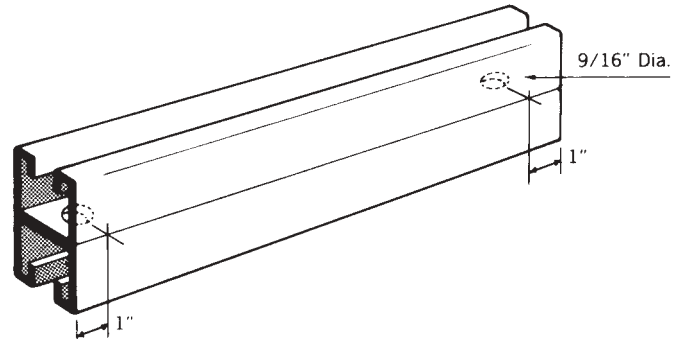

Cat. No.	Multi-Strut Channel Size	Wt/ft.
T-122	M-122	2.54#
T-132	M-132	1.94#
T-134	M-134	1.45#
T-142	M-142	1.76#
T-152	M-152	1.49#
T-162	M-162	1.35#
T-164	M-164	1.03#
T-165	M-165	.94#

Cat. No.	Multi-Strut Channel Size	Wt/ft.
T-122A	M-122	5.08#
T-132A	M-132	3.88#
T-134A	M-134	2.90#
T-142A	M-142	3.52#
T-152A	M-152	2.98#
T-162A	M-162	2.70#
T-164A	M-164	2.06#
T-165A	M-165	1.70#

NOTE: Other hole locations and diameters available on request.  
ORDERING: Specify catalog number, length and finish.

## T-610 SINGLE CHANNEL BRACKET

ORDERING: Specify catalog number, length and finish

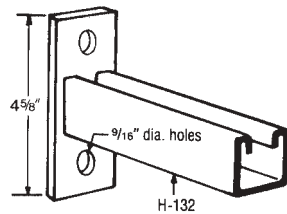

## T-611 DOUBLE CHANNEL BRACKET

ORDERING: Specify catalog number, length and finish

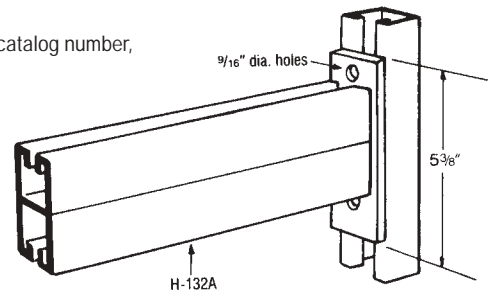

# FLAT PLATE

## T-612 BRACKET

A	Wt. lbs./C
6"	191
12"	292

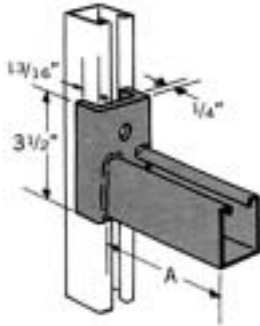

## T-613 BRACKET

A	Wt. lbs./C
6"	191
12"	292

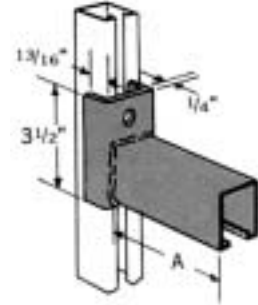

## T-615 BRACKET

Note: Use with M-132, M-134 Channel

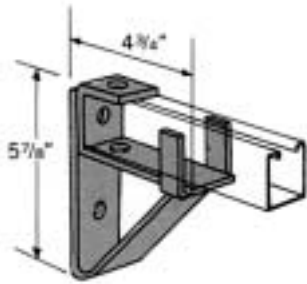

## T-616 BRACKET

Note: Use with M-132, M-134 Channel

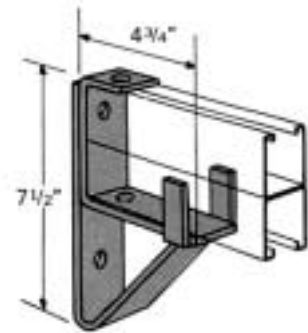

# ANGLE BRACKETS

**DATA:**  
 1/4" thick, 1 5/8" wide, holes 9/16" dia.,  
 spaced 1 7/8" on center & 1 3/16" from end.

FINISH: Electro-Galvanized

## T-620 SHELF BRACKET (Right-hand shown)

Catalog Number		A	B	C
Left Hand	Right Hand			
T-620/6-L	T-620/6-R	6"	2 <sup>15</sup> / <sub>16</sub> "	3"
T-620/8-L	T-620/8-R	8"	2 <sup>15</sup> / <sub>16</sub> "	5"
T-620/10-L	T-620/10-R	10"	2 <sup>15</sup> / <sub>16</sub> "	7"

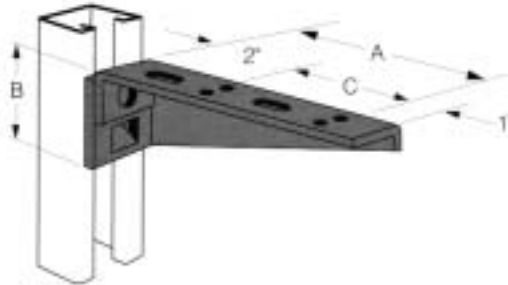

## T-621 SHELF BRACKET (Right-hand shown)

Catalog Number		A	B	C
Left Hand	Right Hand			
T-621/12-L	T-621/12-R	12"	3 <sup>7</sup> / <sub>16</sub> "	3"
T-621/14-L	T-621/14-R	14"	3 <sup>15</sup> / <sub>16</sub> "	4"
T-621/16-L	T-621/16-R	16"	4 <sup>7</sup> / <sub>16</sub> "	5"
T-621/18-L	T-621/18-R	18"	4 <sup>15</sup> / <sub>16</sub> "	6"
T-621/20-L	T-621/20-R	20"	5 <sup>1</sup> / <sub>16</sub> "	7"
T-621/22-L	T-621/22-R	22"	5 <sup>15</sup> / <sub>16</sub> "	8"

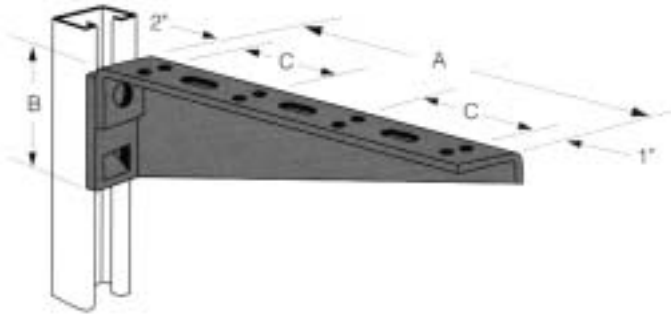

## T-622 SHELF BRACKET (Right-hand shown)

Catalog Number		A	B	C
Left Hand	Right Hand			
T-622/24-L	T-622/24-R	24"	6 <sup>7</sup> / <sub>16</sub> "	5"
T-622/26-L	T-622/26-R	26"	6 <sup>15</sup> / <sub>16</sub> "	5 <sup>11</sup> / <sub>16</sub> "
T-622/28-L	T-622/28-R	28"	7 <sup>7</sup> / <sub>16</sub> "	6 <sup>5</sup> / <sub>16</sub> "
T-622/30-L	T-622/30-R	30"	7 <sup>15</sup> / <sub>16</sub> "	7"

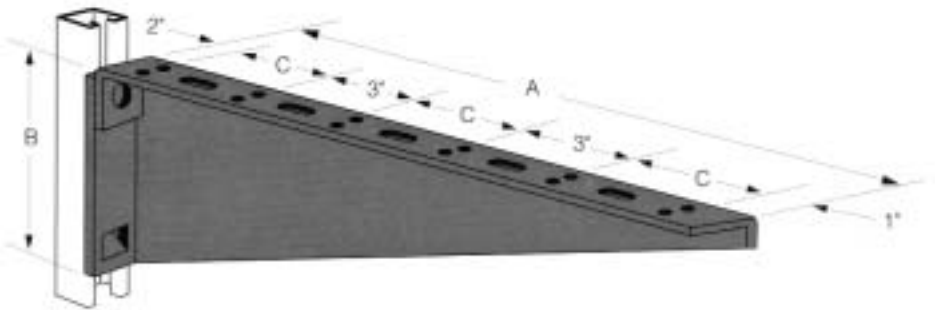

## SECTION VIII MINI STRUT 1<sup>3</sup>/<sub>16</sub>" WIDE CHANNELS

---

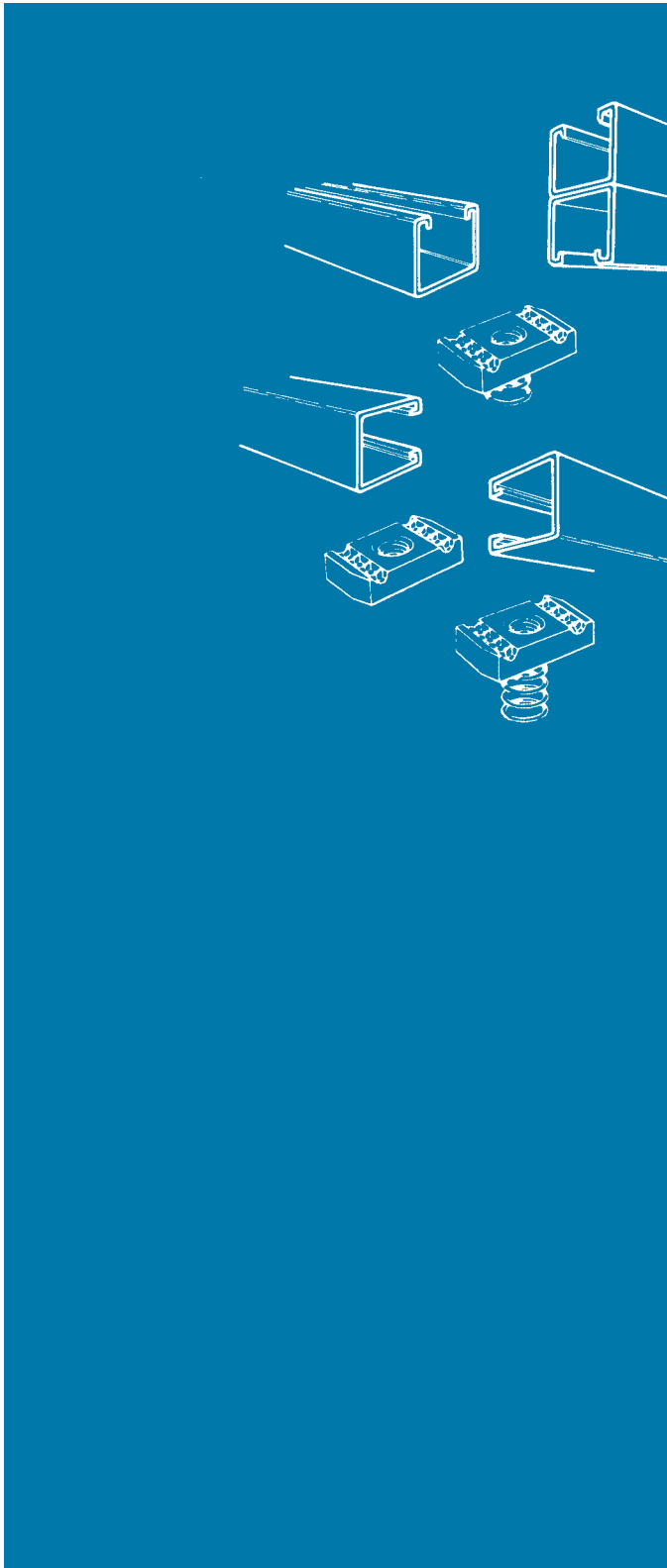

### SPECIFICATIONS

#### GENERAL

Multi-Strut mini-channel is manufactured by a series of forming dies or rolls which progressively cold work the strip steel into the desired channel configuration. Multi-Strut mini-nuts are designed with specially formed teeth so as to grip the return lip of the mini-channel, assuring a secure lock.

#### MATERIAL

Multi-Strut mini-channel is produced from 19 gauge prime steel. Multi-Strut mini-nuts are manufactured from mild steel strip and are case hardened.

#### FINISH

Multi-Strut mini-channel is stocked in both plain and pre-galvanized finishes. Multi-Strut mini-nuts have an electro-galvanized finish. Other finishes are available upon request.

#### LENGTH

Multi-Strut mini-channel is stocked in 10 foot lengths. Other lengths are available upon request.

#### WELDING

Multi-Strut back to back mini-channel is a combination of two pieces of channel welded together, with spotwelds spaced three inches on center throughout the length of the channel.

#### ORDERING

Please specify catalog number, finish and length.

# MINI STRUT

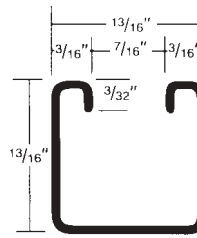

**M-179**  
 1 3/16" x 1 3/16" x 1 3/16"  
 19 Gauge Channel  
 wt./100 ft. - 40#

Stocked in Pre Galvanized & Plain in 10 ft. lengths.

**M-179A**

1 5/8" x 1 3/16" x 1 5/8" x 19GA  
 BACK TO BACK



**M-189A**

1 3/16" x 1 3/16" x 1 3/8" x 19GA  
 BACK TO BACK

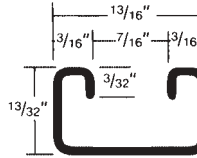
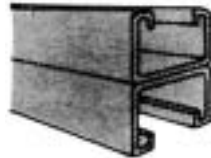

**M-189**  
 1 3/32" x 1 3/16" x 1 3/32"  
 19 Gauge Channel  
 wt./100 ft. - 28#

Stocked in Pre Galvanized & Plain in 10 ft. lengths.

**PROPERTIES OF SECTION**

Figure Number	Wt./Ft. Lbs.	Area of Section Sq. in.	X-X Axis			Y-Y Axis		
			Ix in. <sup>4</sup>	Sx in <sup>3</sup>	Rx in.	Iy in. <sup>4</sup>	Sy in <sup>3</sup>	Ry in.
M-179	.40	0.1076	0.009	0.020	0.292	0.012	0.029	0.332
M-179A	.80	0.2152	0.045	0.055	0.455	0.024	0.058	0.332
M-189	.28	0.0743	0.002	0.007	0.147	0.007	0.017	0.305
M-189A	.56	0.1486	0.007	0.018	0.219	0.014	0.034	0.305

**ALLOWABLE COLUMN LOADS (LBS.)**

Figure Number	UNSUPPORTED HEIGHT OF COLUMN IN INCHES												
	12"	18"	24"	30"	36"	42"	48"	60"	72"	84"	96"	108"	120"
M-179	1246	1010	777	600	493	419	364	-	-	-	-	-	-
M-179A	2942	2827	2667	2460	2208	1909	1565	1002	-	-	-	-	-
M-189	1235	748	421	-	-	-	-	-	-	-	-	-	-
M-189A	2903	2460	1841	1198	832	611	-	-	-	-	-	-	-

**ALLOWABLE BEAM LOADS (LBS.)**

Figure Number	Notes	SPAN IN INCHES												
		12"	18"	24"	30"	36"	42"	48"	60"	72"	84"	96"	108"	120"
M-179	1	330	220	165	132	110	94	83	66	55	47	41	37	33
	2	-	-	150	96	67	49	38	24	17	12	9	7	6
	3	0.027	0.062	0.110	0.171	0.247	0.336	0.439	0.685	0.987	1.344	1.755	2.221	2.742
M-179A	1	-	-	-	-	291	261	228	183	152	131	114	102	91
	2	-	-	-	-	-	238	183	117	81	60	46	36	29
	3	0.016	0.035	0.063	0.098	0.141	0.192	0.250	0.391	0.563	0.767	1.001	1.267	1.565
M-189	1	109	73	54	44	36	31	27	22	18	16	14	12	11
	2	105	47	26	17	12	9	7	4	3	2	2	1	1
	3	0.052	0.117	0.208	0.325	0.469	0.638	0.833	1.302	1.875	2.551	3.332	4.218	5.207
M-189A	1	-	-	144	116	97	83	73	58	49	42	36	32	29
	2	-	-	116	74	52	38	29	19	13	9	7	6	5
	3	0.031	0.070	0.125	0.196	0.282	0.383	0.501	0.782	1.126	1.533	2.003	2.535	3.129

**NOTES:**

- I. All Figures show the Load in Lbs.
- II. Line 1 shows the Allowable Uniform Beam Load based on calculations using 25000 psi Stress.
- III. Line 2 shows the Allowable Uniform Load at Maximum Deflection = 1/240 of Span.
- IV. Line 3 shows Beam Deflection in inches.

# MINI STRUT GRIP LOCK NUTS

**DATA:**

Finished in Electro-Galvanized

The case hardened carbon steel nuts are designed with special formed teeth in the parallel channel recesses. The nuts are made to grip the returned lip of the channel. The shearing action of the teeth assures a positive locking of the H-Strut channels to the fittings. The selection table shows the correct locking nuts for each size channel.

**WITHOUT SPRING**

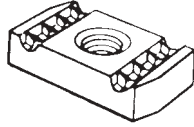

Cat. No.	Size	Thd	Thk	Wt./100 pc.	Channel
N-841	8	32	5/32"	1	M-179, M-189
N-842	10	32	5/32"	1	
N-843	10	24	5/32"	1	
N-844	1/4	20	5/32"	1	

**SHORT SPRING**

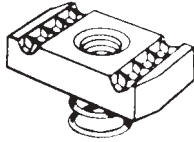

Cat. No.	Size	Thd	Thk	Wt./100 PC.	Channel
N-851	8	32	5/32"	1	M-189
N-852	10	32	5/32"	1	
N-853	10	24	5/32"	1	
N-854	1/4	20	5/32"	1	

**REGULAR SPRING**

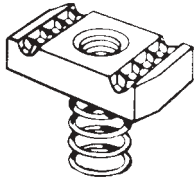

Cat. No.	Size	Thd	Thk	Wt./100 PC.	Channel
N-861	8	32	5/32"	1	M-179
N-862	10	32	5/32"	1	
N-863	10	24	5/32"	1	
N-864	1/4	20	5/32"	1	

# SECTION IX STAINLESS CHANNELS & ACCESSORIES

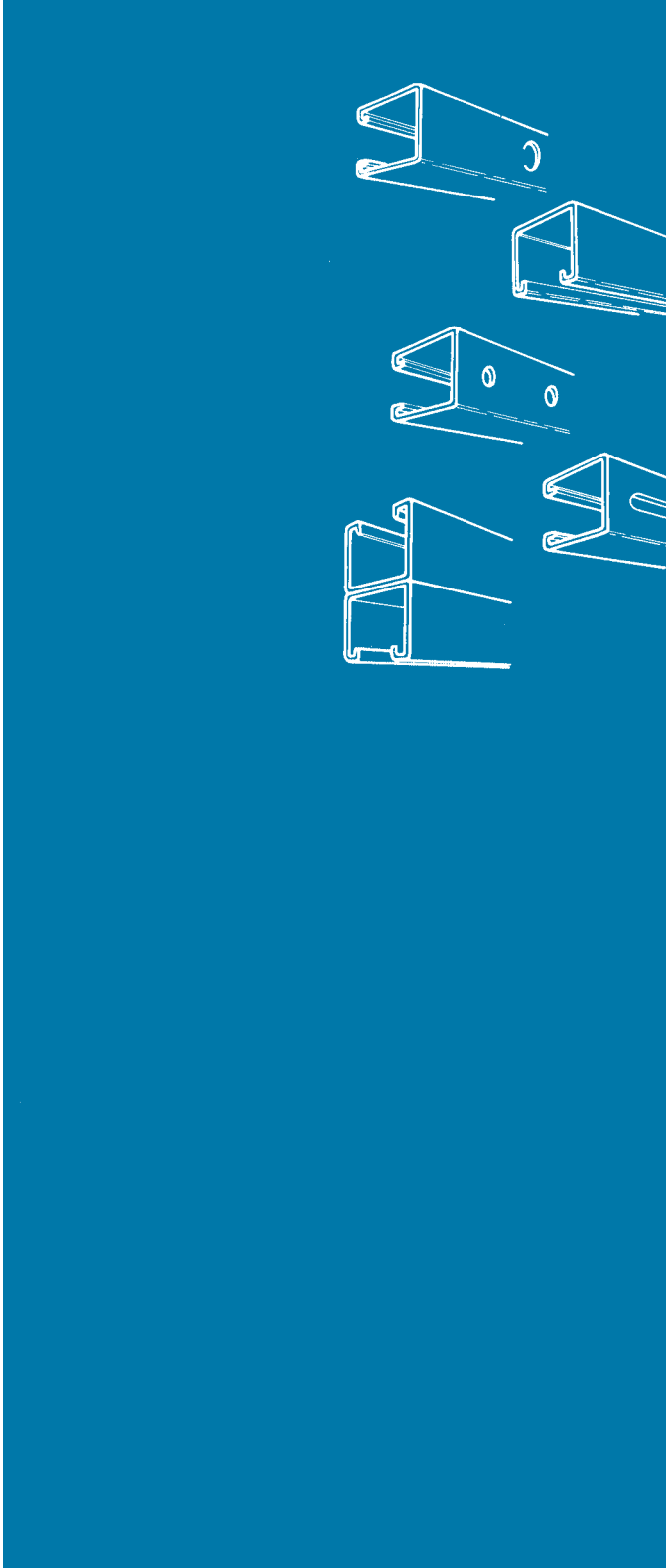

## SPECIFICATIONS

### GENERAL

Multi-Strut channels are manufactured by a series of forming dies or rolls which progressively cold work the strip steel into the desired channel configuration. This method produces a cross section of uniform dimensions within a tolerance of plus or minus .015" on outside dimensions.

### MATERIAL

Multi-Strut stainless channels are produced from stainless steel covering the following specifications:

TYPE 304 .....ASTM A240 T304  
TYPE 316 .....ASTM A240 T316

### LENGTH INFORMATION

Multi-Strut channels are produced and stocked in 10 and 20 foot lengths. Other lengths are available upon request.

### FINISHES

Multi-Strut channels and accessories are stocked in stainless steel type 304 and 316.

### ORDERING

Please specify catalog number, steel type, size and length where applicable.

### LOADING DATA

- 1) For concentrated beam loads at center of span, multiply the load shown in table by .5 and deflection by .8.
- 2) For fabricated channels, reduce the beam loads by the percentage as follows:
  - KO = 5%
  - RS = 10%
  - OS = 15%
  - OS3 = 30%

# STAINLESS STEEL CHANNEL/M-132SS

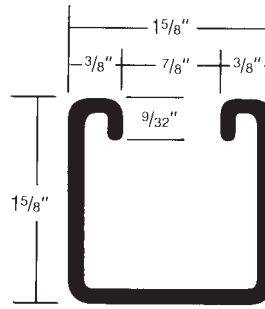

1 5/8" x 1 5/8" x 1 5/8"  
12 Gauge Channel  
wt./100 ft. - 194#

Stocked in type 304 and 316 grade  
Stainless Steel in 10 & 20 ft. lengths.



**M-132SS-OS**  
1 5/8" x 1 5/8" x 1 5/8" x 12GA 9/16"  
x 1 1/8" Slot;  
2" on Centers

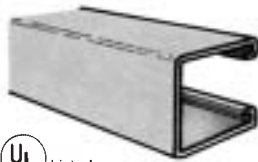

**M-132SS-NS**  
1 5/8" x 1 5/8" x 1 5/8" x 12GA

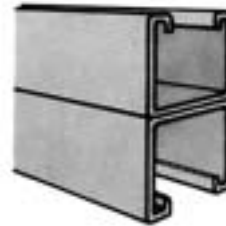

**M-132SS-A**  
3 1/4" x 1 5/8" X 3 1/4" x 12GA  
Back to Back

\*Other welded combinations  
available upon request

## PROPERTIES OF SECTION

Figure Number	Wt./Ft. Lbs.	Area of Section Sq. in.	X-X Axis			Y-Y Axis		
			Ix in. <sup>4</sup>	Sx in <sup>3</sup>	Rx in.	Iy in. <sup>4</sup>	Sy in <sup>3</sup>	Ry in.
M-132SS	1.94	.544	0.180	0.195	0.575	0.233	0.287	0.655
M-132SS-A	3.88	1.088	0.896	0.570	0.908	0.466	0.5736	0.655

## ALLOWABLE COLUMN LOADS (LBS.)

Figure Number	UNSUPPORTED HEIGHT OF COLUMN IN INCHES												
	12"	18"	24"	30"	36"	42"	48"	60"	72"	84"	96"	108"	120"
M-132SS	7573	7455	7290	7077	6817	6509	6154	5303	4263	3172	2428	1919	1554
M-132SS-A	15190	15007	14752	14423	14021	13547	12999	11885	10078	8180	6291	4971	4026

## ALLOWABLE BEAM LOADS (LBS.)

Figure Number	Notes	SPAN IN INCHES												
		12"	18"	24"	30"	36"	42"	48"	60"	72"	84"	96"	108"	120"
M-132SS	1	3249	2166	1625	1300	1093	928	812	650	542	464	406	361	325
	2	-	-	-	-	-	-	737	472	328	241	184	148	118
	3	0.014	0.031	0.055	0.086	0.124	0.169	0.220	0.344	0.496	0.675	0.882	1.116	1.378
M-132SS-A	1	9496	6331	4748	3799	3185	2713	2374	1899	1583	1357	1187	1055	950
	2	-	-	-	-	-	-	-	-	-	1199	918	725	587
	3	0.00	8 0.018	0.032	0.051	0.073	0.099	0.129	0.202	0.291	0.396	0.517	0.655	0.808

### NOTES:

- I. All Figures show the Load in Lbs.
- II. Line 1 shows the Allowable Uniform Beam Load based on calculations using 25000 psi Stress.
- III. Line 2 shows the Allowable Uniform Load at Maximum Deflection = 1/240 of Span.
- IV. Line 3 shows Beam Deflection in inches.



# STAINLESS STEEL CHANNEL/M-164SS

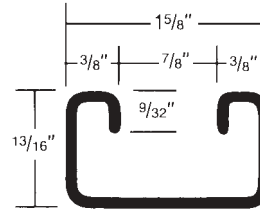

1 3/16" x 1 5/8" x 1 3/16"  
14 Gauge Channel  
wt./100 ft. - 103#

Stocked in type 304 and 316  
grade Stainless Steel in 10 & 20  
ft. lengths.



**M-164SS-OS**  
1 3/16" x 1 5/8" x 1 3/16" x 14GA 9/16"  
x 1 1/8" Slot;  
2" on Centers



**M-164SS-KO**  
1 3/16" x 1 5/8" x 1 3/16" x 14GA

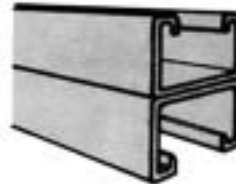

**M-164SS-A**  
1 5/8" x 1 5/8" x 1 5/8" x 14GA  
Back to Back

\*Other welded combinations  
available upon request

## PROPERTIES OF SECTION

Figure Number	Wt./Ft. Lbs.	Area of Section Sq. in.	X-X Axis			Y-Y Axis		
			Ix in. <sup>4</sup>	Sx in <sup>3</sup>	Rx in.	Iy in. <sup>4</sup>	Sy in <sup>3</sup>	Ry in.
M-164SS	1.03	0.286	0.025	0.053	0.298	0.106	0.131	0.610
M-164SS-A	2.06	0.571	0.115	0.149	0.449	0.213	0.2619	0.610

## ALLOWABLE COLUMN LOADS (LBS.)

Figure Number	UNSUPPORTED HEIGHT OF COLUMN IN INCHES												
	12"	18"	24"	30"	36"	42"	48"	60"	72"	84"	96"	108"	120"
M-164SS	3710	3487	3175	2773	2282	1729	1324	847	588	432	331	261	212
M-164SS-A 1	7620	7424	7148	6795	6362	5851	5261	3847	2671	1963	1503	1187	962

## ALLOWABLE BEAM LOADS (LBS.)

Figure Number	Notes	SPAN IN INCHES												
		12"	18"	24"	30"	36"	42"	48"	60"	72"	84"	96"	108"	120"
M-164SS	1	888	592	444	355	296	254	222	178	148	127	111	99	89
	2	-	-	416	266	185	136	104	67	46	34	26	21	17
	3	0.027	0.060	0.107	0.167	0.240	0.327	0.427	0.667	0.960	1.307	1.708	2.161	2.668
M-164SS-A	1	2478	1652	1239	991	826	708	619	496	413	354	310	275	248
	2	-	-	-	-	-	617	472	302	210	154	118	93	76
	3	0.016	0.037	0.066	0.102	0.148	0.201	0.262	0.410	0.590	0.804	1.050	1.328	1.640

### NOTES:

- I. All Figures show the Load in Lbs.
- II. Line 1 shows the Allowable Uniform Beam Load based on calculations using 25000 psi Stress.
- III. Line 2 shows the Allowable Uniform Load at Maximum Deflection = 1/240 of Span.
- IV. Line 3 shows Beam Deflection in inches.

# STAINLESS STEEL PIPE CLAMPS

## C-1101SS O.D. CLAMPS

FINISH: Type 304 and 316 Grade  
Stainless Steel

ORDERING: Specify Figure Number,  
O.D. Size and Steel Grade

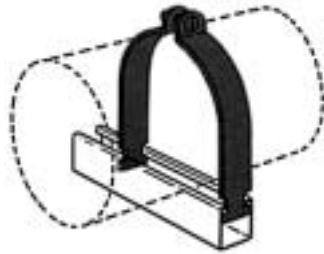

O. D. Size	Tube Size	Steel Ga.	Wt. C. Pcs.	Std. Pkg.	O. D. Size	Tube Size	Steel Ga.	Wt. C. Pcs.	Std. Pkg.
1/4"	1/8"	16	8	100	3 1/8"	3"	12	42	50
3/8"	1/4"	16	8	100	3 1/4"	3 1/8"	12	42	50
1/2"	3/8"	16	8	100	3 3/8"	3 1/4"	12	43	50
5/8"	1/2"	16	9	100	3 1/2"	3 3/8"	12	44	50
3/4"	5/8"	16	11	100	3 5/8"	3 1/2"	11	56	25
7/8"	3/4"	16	11	100	3 3/4"	3 5/8"	11	57	25
1"	7/8"	14	13	100	3 7/8"	3 3/4"	11	57	25
1 1/8"	1"	14	15	100	4"	3 7/8"	11	61	25
1 1/4"	1 1/8"	14	16	100	4 1/8"	4"	11	61	25
1 3/8"	1 1/4"	14	17	100	4 1/4"	4 1/8"	11	64	25
1 1/2"	1 3/8"	14	18	100	4 3/8"	4 1/4"	11	64	25
1 5/8"	1 1/2"	14	19	50	4 1/2"	4 3/8"	11	66	25
1 3/4"	1 5/8"	12	19	50	4 5/8"	4 1/2"	11	66	25
1 7/8"	1 3/4"	12	28	50	4 3/4"	4 5/8"	11	68	25
2"	1 7/8"	12	31	100	4 7/8"	4 3/4"	11	73	25
2 1/8"	2"	12	31	50	5"	4 7/8"	11	74	25
2 1/4"	2 1/8"	12	33	50	5 1/8"	5"	11	70	25
2 3/8"	2 1/4"	12	34	50	5 1/4"	5 1/8"	11	70	25
2 1/2"	2 3/8"	12	35	50	5 3/8"	5 1/4"	11	77	25
2 5/8"	2 1/2"	12	36	50	5 1/2"	5 3/8"	11	78	25
2 3/4"	2 5/8"	12	37	50	5 5/8"	5 1/2"	10	83	25
2 7/8"	2 3/4"	12	39	50	5 3/4"	5 5/8"	10	84	25
3"	2 7/8"	12	41	50	5 7/8"	5 3/4"	10	85	25
					6"	5 7/8"	10	94	20

## C-1102SS PIPE CLAMPS

FINISH: Type 304 and 316 Grade  
Stainless Steel

ORDERING: Specify Figure Number,  
O.D. Size and Steel Grade

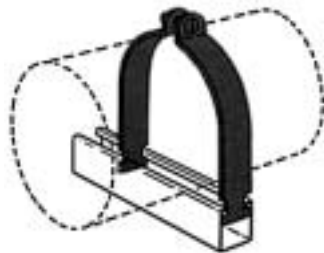

Pipe Size	O. D. Size	Steel Ga.	Wt. C. Pcs.	Std. Pkg.
1/4"	0.675	16	12	100
1/2"	0.840	16	13	100
3/4"	1.050	14	15	100
1"	1.315	14	18	100
1 1/4"	1.660	14	22	100
1 1/2"	1.900	12	32	50
2"	2.375	12	37	50
2 1/2"	2.875	12	42	50
3"	3.500	12	49	50
3 1/2"	4.000	11	65	40
4"	4.500	11	69	40
5"	5.563	11	82	20
6"	6.625	10	107	20
8"	8.625	10	133	Bulk
10"	10.75	10	143	Bulk

ADDITIONAL ACCESSORIES AVAILABLE UPON REQUEST.

# STAINLESS STEEL ACCESSORIES

**A-301SS**  
TWO HOLE  
CORNER ANGLE

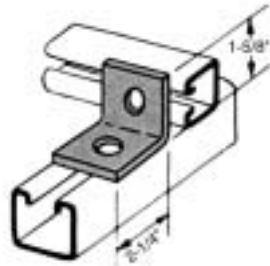

**A-311SS**  
FOUR HOLE  
ANGLE

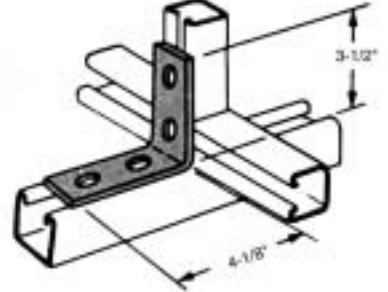

**F-205SS**  
FOUR HOLE  
SPLICE PLATE

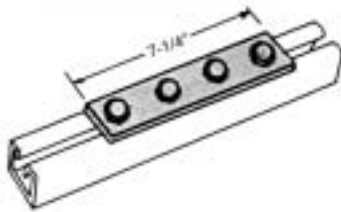

**C-1109SS**  
ONE HOLE  
TUBING CLAMP

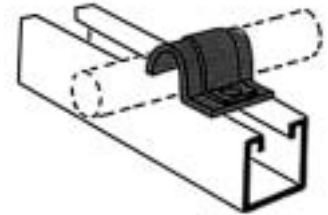

**STRUT NUT**

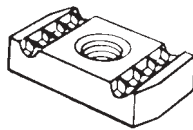

**FLAT WASHERS**



**HEX NUTS**

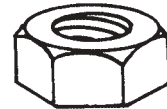

**HEX HEAD  
CAP SCREW**

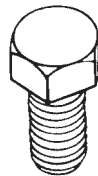

**ALL-THREAD  
ROD**

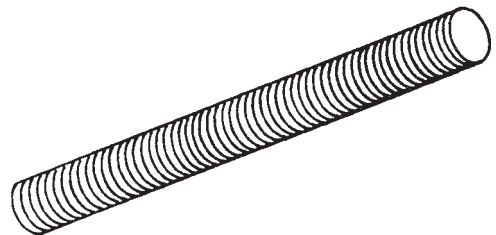

## SECTION X SEISMIC BRACING

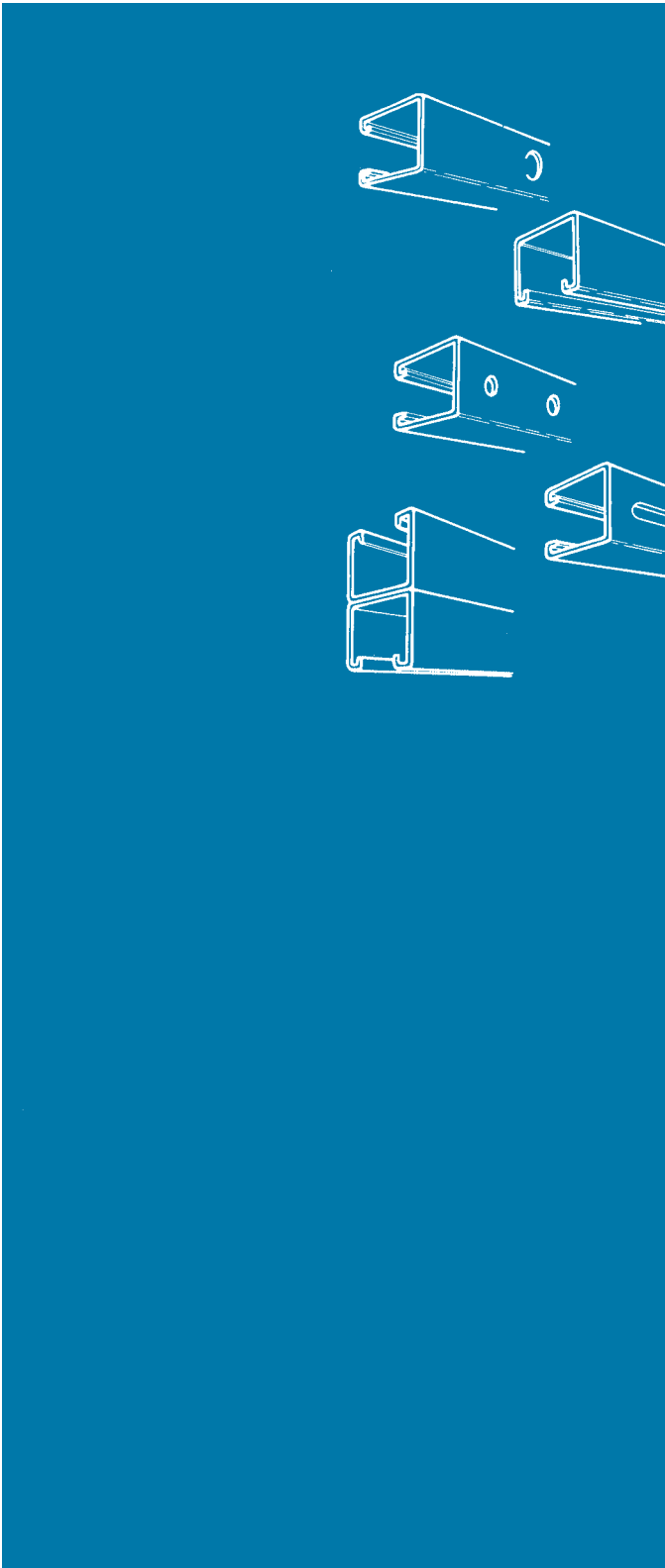

---

### GENERAL

PHS Industries Inc. is committed and dedicated to providing state-of-the-art seismic bracing products which provide professional and simple solutions to complex seismic requirements and codes. We offer a full line of seismic bracing systems and accessories which have been developed based upon cost effectiveness, functionality and reliability.

### ORDERING

We recommend consulting our technical services group prior to selecting and installing any seismic bracing. Our technical services group is staffed by engineers thoroughly experienced in the design and application of seismic bracing systems.

PHS Industries Inc. is available to review your requirements and specifications, and recommend system solutions to your seismic bracing requirements. We have the capability to perform various types of analyses based upon specific applications.

Multi-Strut seismic braces are available in many different combinations and sizes based upon your specific applications. On the following pages are some typical examples of Multi-Strut seismic braces.

# SEISMIC BRACING

## DETAIL SR-1

Item No.	No. Req'd.	Fig No. Part No.	Description
1	1		Vibration Isolator*
2	4	WRT	Rope Thimble
3	8	SCC	Cable Clamp*
4	2	KB	Wedge Anchor*
5	4	3HSB	Seismic Bracket*
6	2	GAC	Galvanized Cable*

\*Size based upon application.

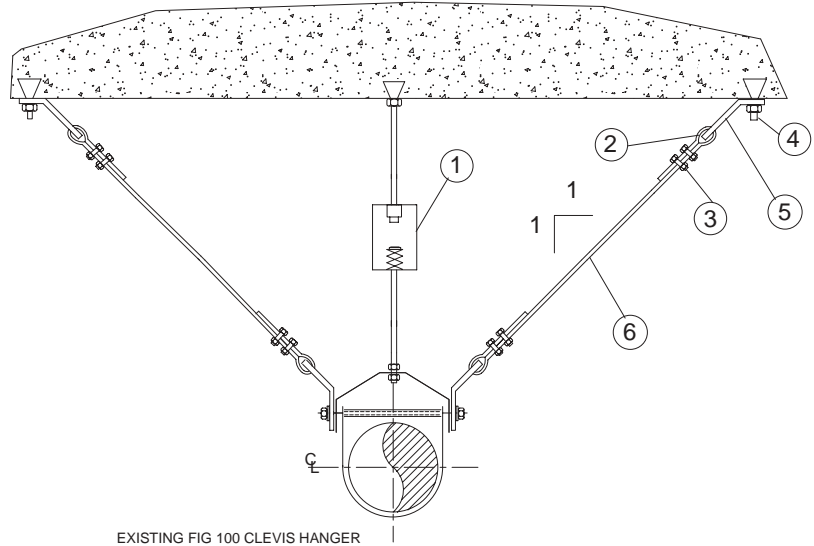

## DETAIL SR-2

Item No.	No. Req'd.	Fig No. Part No.	Description
1	4	WRT	Rope Thimble
2	8	SCC	Cable Clamp*
3	2	KB	Wedge Anchor*
4	4	3HSB	Seismic Bracket*
5	2	GAC	Galvanized Cable*
6	2	C402	Beam Clamp
7	1	M132	Multi-Strut Channel

\*Size based upon application.

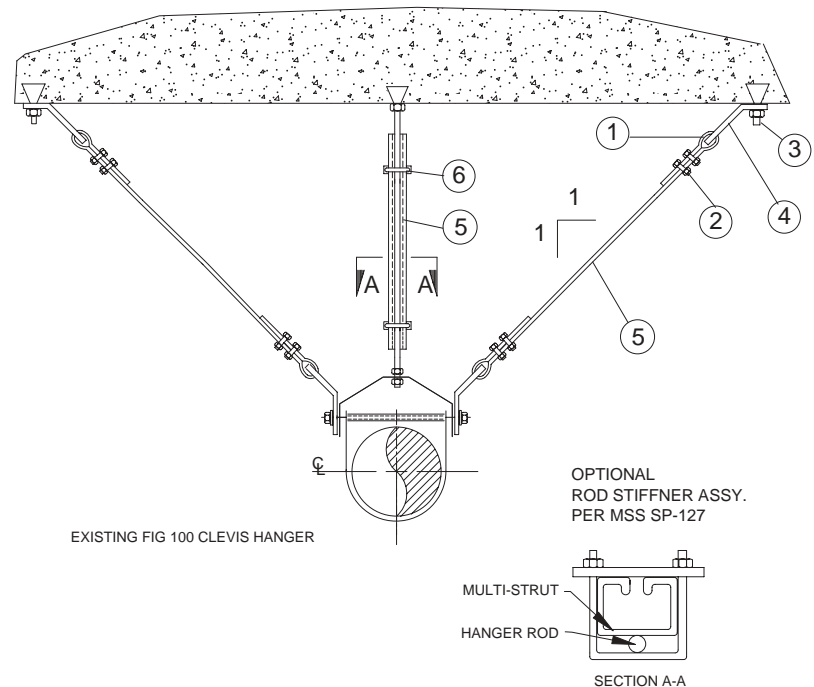

# SEISMIC BRACING

## DETAIL SR-3

Item No.	No. Req'd.	Fig No. Part No.	Description
1	1	M132	Multi-Strut Channel
2	2	SN	Strut Nut
3	4	BLT	Hex Head Cap Screw
4	1	KB	Wedge Anchor*
5	2	3HSB	Seismic Bracket*
6	1	MXXX	Multi-Strut Channel*
7	2	C402	Beam Clamp

\*Size based upon application.

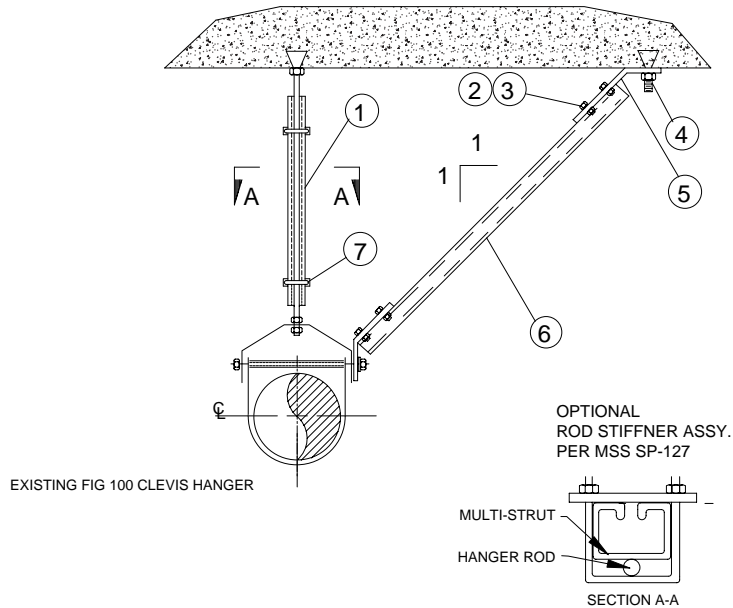

## DETAIL SR-5

Item No.	No. Req'd.	Fig No. Part No.	Description
1	1	M132	Multi-Strut Channel
2	4	SN	Strut Nut
3	4	BLT	Hex Head Cap Screw
4	1	KB	Wedge Anchor*
5	2	SH300	Seismic Bracket*
6	1	MXXX	Multi-Strut Channel*
7	2	C402	Beam Clamp

\*Size based upon application.

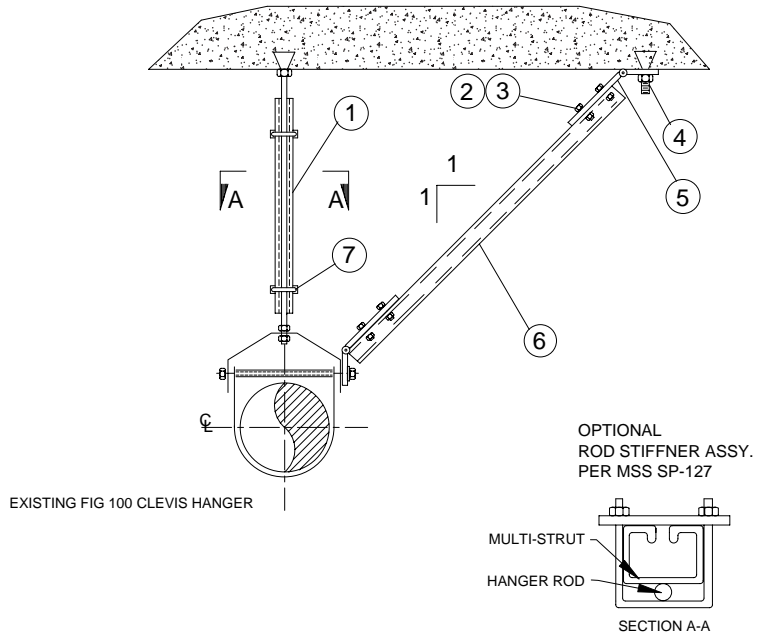

# SEISMIC BRACING

**DETAIL SR-8**

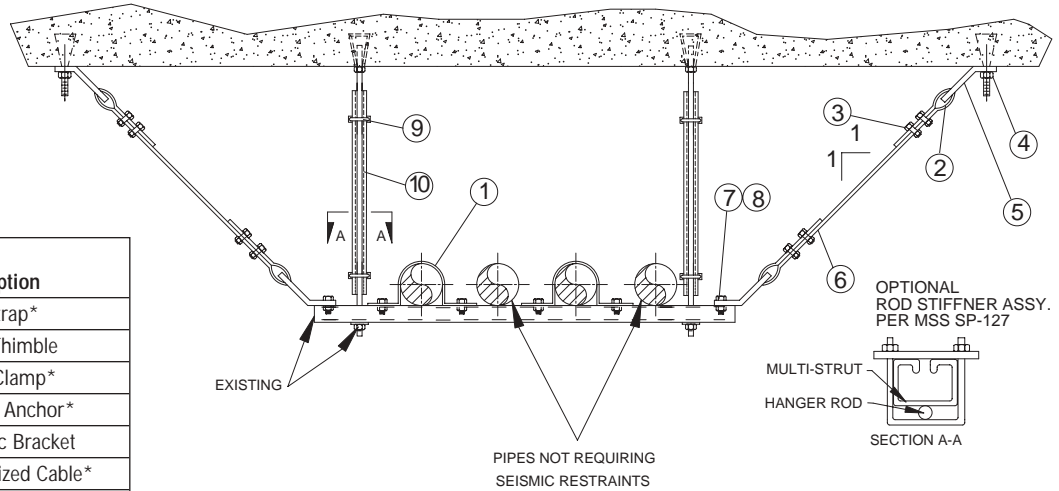

Item No.	No. Req'd.	Fig No. Part No.	Description
1	2	C1108	Pipe Strap*
2	4	WRT	Rope Thimble
3	8	SCC	Cable Clamp*
4	2	KB	Wedge Anchor*
5	4	3HSB	Seismic Bracket
6	2	GAC	Galvanized Cable*
7	6	BLT	Hex Head Cap Screw
8	6	SN	Strut Nut
9	4	C402	Beam Clamp
10	2	M132	Multi-Strut Channel

\*Size based upon application.

**DETAIL SR-9**

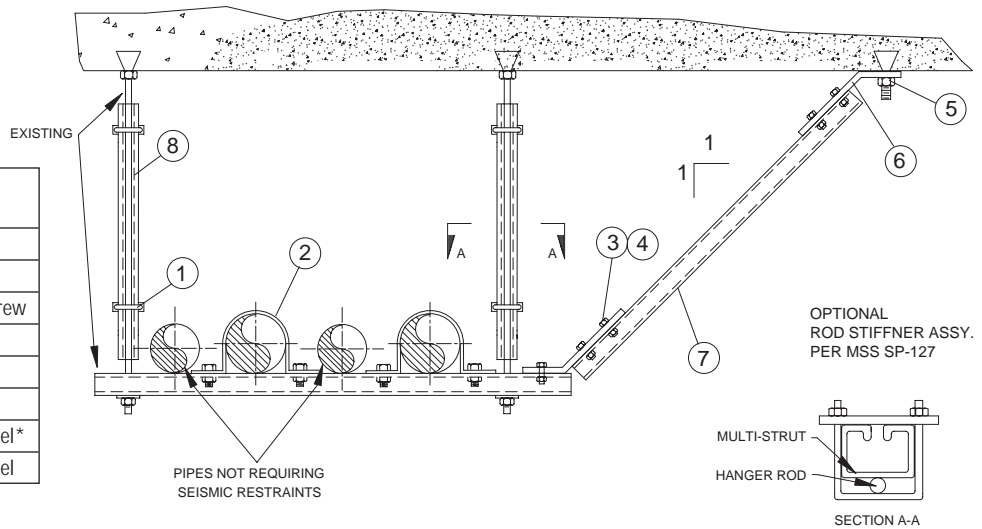

Item No.	No. Req'd.	Fig No. Part No.	Description
1	4	SAC	Seismic Clamp
2	2	C1108	Pipe Strap*
3	9	BLT	Hex Head Cap Screw
4	9	SN	Strut Nut
5	1	KB	Wedge Anchor*
6	2	3HSB	Seismic Angle
7	1	MXXX	Multi-Strut Channel*
8	2	M132	Multi-Strut Channel

\*Size based upon application.

# SEISMIC BRACING

## DETAIL SR-11

Item No.	No. Req'd.	Fig No. Part No.	Description
1	2	M132	Multi-Strut Channel
2	2	C1108	Pipe Strap*
3	9	BLT	Hex Head Cap Screw
4	9	SN	Strut Nut
5	1	KB	Wedge Anchor*
6	2	SH300	Seismic Angle
7	1	MXXX	Multi-Strut Channel*
8	4	SAC	Seismic Clamp

\*Size based upon application.

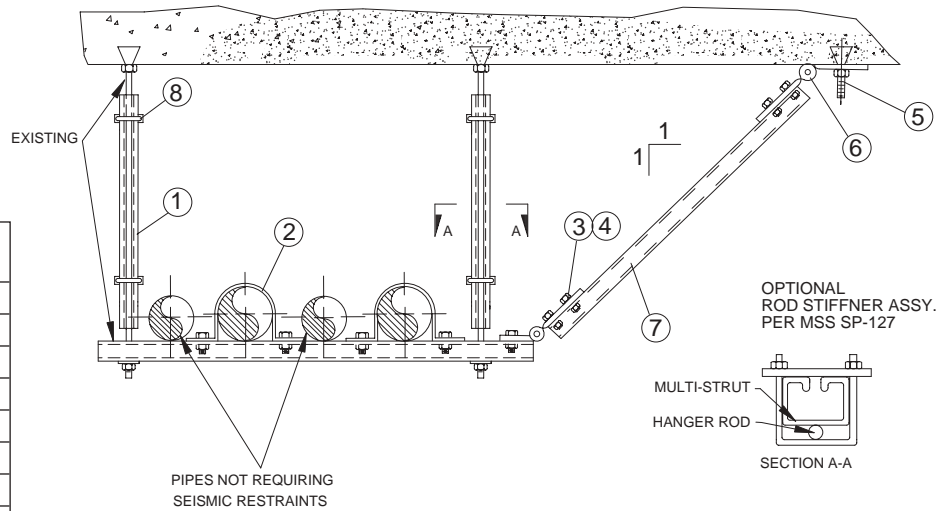

## DETAIL SR-12

Item No.	No. Req'd.	Fig No. Part No.	Description
1	2	BLT	Hex Head Cap Screw
2	2	SN	Strut Nut
3	1	KB	Wedge Anchor*
4	1	SH300	Seismic Bracket
5	1	MXXX	Multi-Strut Channel*
6	1	C1108	Pipe Strap*

\*Size based upon application.

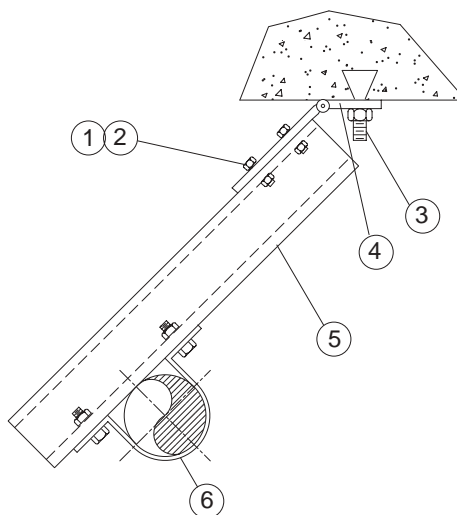



# SEISMIC BRACING

## DETAIL SR-13

Item No.	No. Req'd.	Fig No. Part No.	Description
1	3		Bolt*
2	3	SN	Strut Nut*
3	1	KB	Wedge Anchor*
4	1	3HSB	Seismic Bracket
5	1	MXXX	Multi-Strut Channel*
6	1	175	Pipe Clamp*
7	1	A321	Angle Connector*

\*Size based upon application.

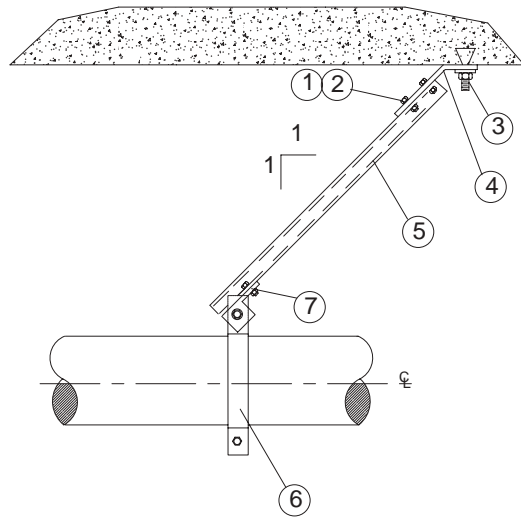

## DETAIL SR-14

Item No.	No. Req'd.	Fig No. Part No.	Description
1	2	SN	Strut Nut
2	2	165H	Heavy Hex Nut
3	1	KB	Wedge Anchor*
4	1	SH300	Seismic Bracket
5	1		Angle Iron*
6	1	175	Pipe Clamp*

\*Size based upon application.

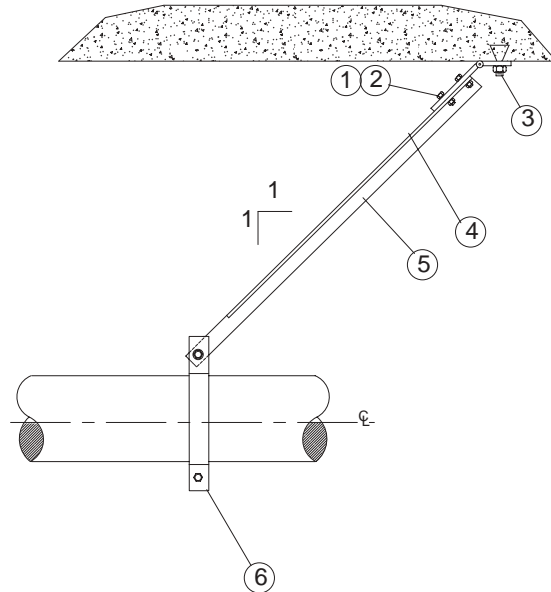

# SEISMIC BRACING

## DETAIL SR-15

Item No.	No. Req'd.	Fig No. Part No.	Description
1	4	165H	Strut Nut
2	4	SN	Hex Head Cap Screw
3	1	KB	Wedge Anchor*
4	2	3HSB	Seismic Bracket*
5	1	MXXX	Multi-Strut Channel*
6	1	140	Harvard Roll Hanger*
7	1	M132	Multi-Strut Channel*
8	2	C402	Beam Clamp

\*Size based upon application.

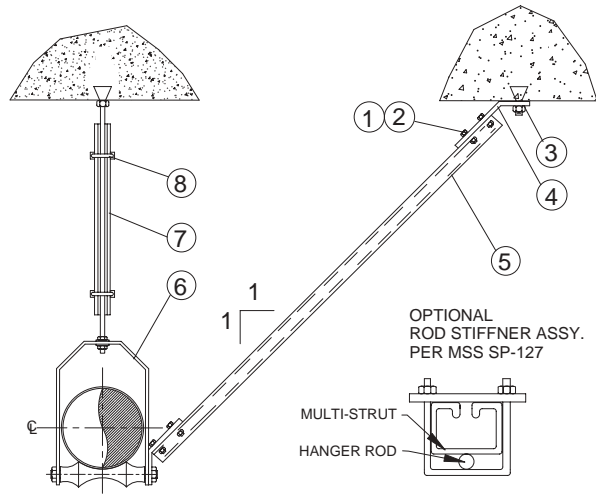

## DETAIL SR-16

Item No.	No. Req'd.	Fig No. Part No.	Description
1	1	175	Pipe Clamp*
2	2	MXXX	Multi-Strut Channel*
3	2	C402	Beam Clamp
4	4	3HSB	Seismic Bracket*
5	8	BLT	Hex Head Bolt*
6	8	SN	Strut Nut*
7	2	KB	Wedge Anchor*
8	4	103	Washer*
9	1	M132	Multi-Strut Channel

\*Size based upon application.

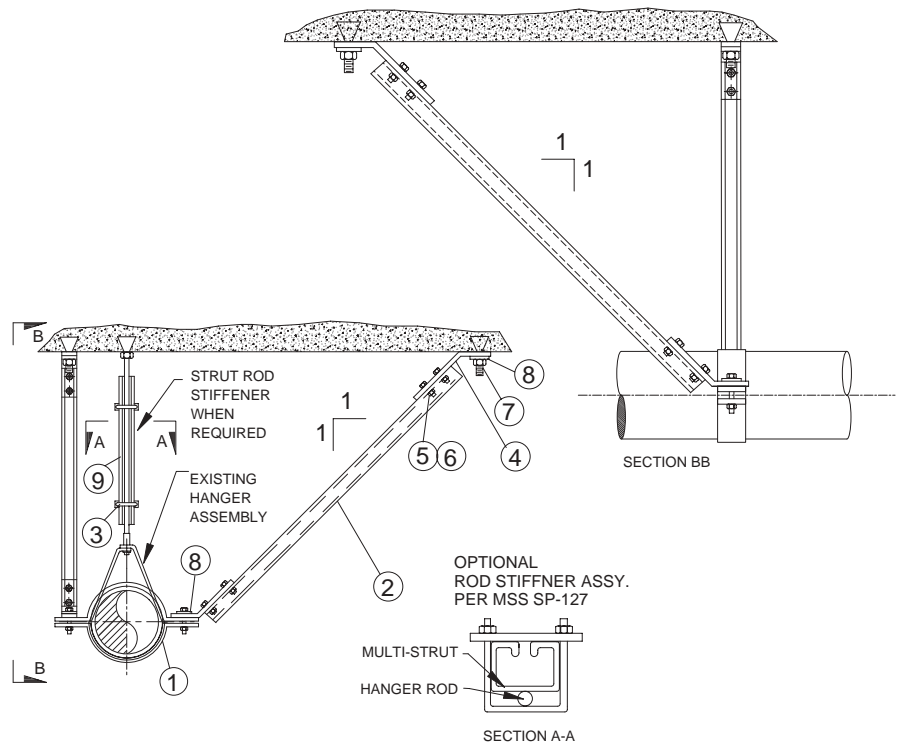

# SEISMIC BRACING

## DETAIL SR-17

Item No.	No. Req'd.	Fig No. Part No.	Description
1	1	126	Riser Clamp*
2	4	F206	3 Hole Splice Plate*
3	8	WRT	Heavy Wire Rope Thimble
4	4		Seismic Cable*
5	4	3HSB	3 Hole Seismic Bracket
6	4		Lag Bolt*
7	16	SCC	Cable Clamp

\*Size based upon application.

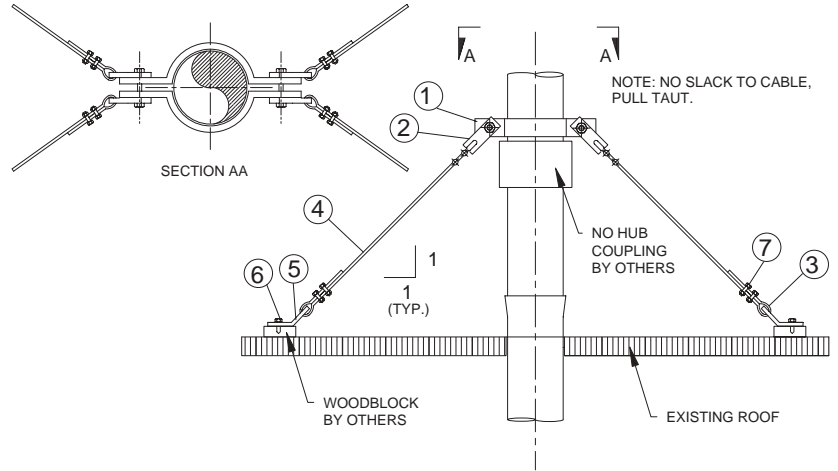

## DETAIL SR-18

Item No.	No. Req'd.	Fig No. Part No.	Description
1	1	175	Pipe Clamp
2	1	F206	3-Hole Splice Plate
3	4	BLT	Bolt
4	4	SN	Strut Nut
5	1	MXXX	Multi-Strut Channel*
6	1	A311	4-Hole Angle
7	2	KB	Wedge Anchor*

\*Size based upon application.

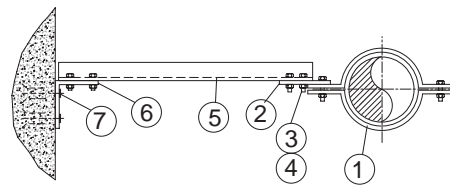

# SECTION XI NON-METALLIC STRUT AND ACCESSORIES

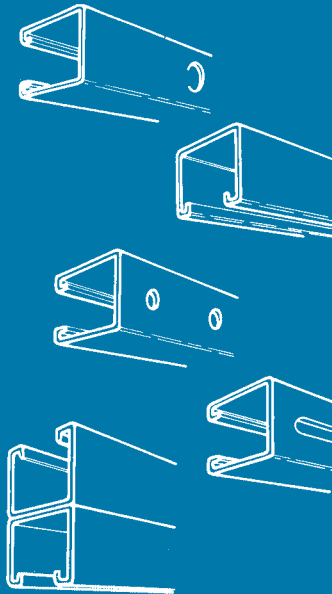

## SPECIFICATIONS

### GENERAL

PHS Industries's non-metallic channel strut framing systems are designed to function where standard metal strut framing system components would be damaged due to corrosion and have a short expected design life span.

### APPLICATIONS

- Waste Water Treatment Plants
- Chemical Plants
- Oil Refineries
- Sewerage Disposal Plants
- Food Processing
- Biotech Plants
- Aquaculture
- Electronics Manufacturing
- Marine
- Ship Building

### STANDARDS

FRP Channels comply with ASTM D 3917 and D 4385  
FRP Materials are Class 1 Fire Rated per ASTM E-84

### ASSEMBLY

The same simple hand tools that are used to cut and drill steel Multi-Strut channel strut can also be used to perform the same function on these non-metallic channel struts as well.

### LENGTH INFORMATION

Non-metallic channel strut is normally available in 10 and 20 foot lengths. Other lengths are available upon request.

### FINISH

Plain

### ORDERING

Please specify channel strut by catalog figure number and length. Specify fittings by figure number and size.

# NON-METALLIC STRUT

## CHANNEL SELECTION GUIDE

### MATERIALS

PHS Industries non-corrosive channel struts are commonly produced with plastic resins such as Polyester or Vinyl ester; although, other types such as Polyvinyl Chloride, Polyurethane, Polypropylene and Nylon are also available. The Polyester and Vinyl ester channels are made from a combination of resin, fiber glass, and an ultra-violet ray resistant surface veil which is pulled (pultruded) through a heated die. While in the die the part is cured to form the completed product.

### SELECTION:

Loading, Temperature, and Chemical Compatibility are the three basic factors that determine the type and size of non-metallic channel strut required.

Loading Factors: Beam, Column, or Cantilever Load  
Uniformly distributed or Point Load  
Flange Loading (Pull Out) Load

Temperatures: Polyester (-35° F to +200° F)  
Vinyl ester (-35° F to +200° F)  
PVC (-25° F to +130° F)  
Polyurethane (-40° F to +140° F)  
Polypropylene (-30° F to +150° F)  
Nylon (-20° F to +150° F)

Chemical Compatibility: Due to the large number of possible variations in the type and concentration of chemicals to be used we may only be able to determine in general the compatibility of the strut material.

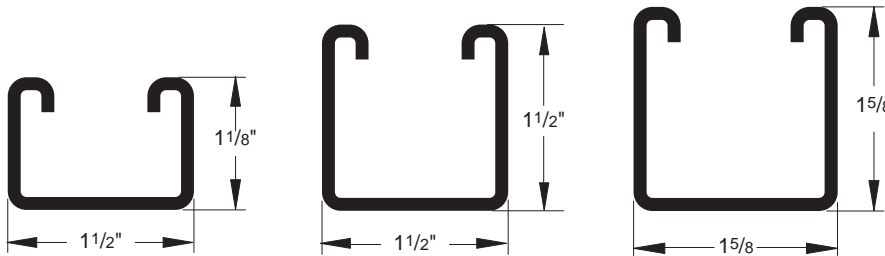

Alternative Channel Configurations are Also Available

### STANDARD LENGTHS

10 feet, 20 feet (+/- 1/4")

Shorter lengths are available at a small cutting charge.

### ACCESSORIES

Please contact our office to discuss your requirements for related clamps, post bases, angle fittings, flat plate fittings and fasteners that you may require.

# SECTION XII TECHNICAL SECTION AND INDEX

---

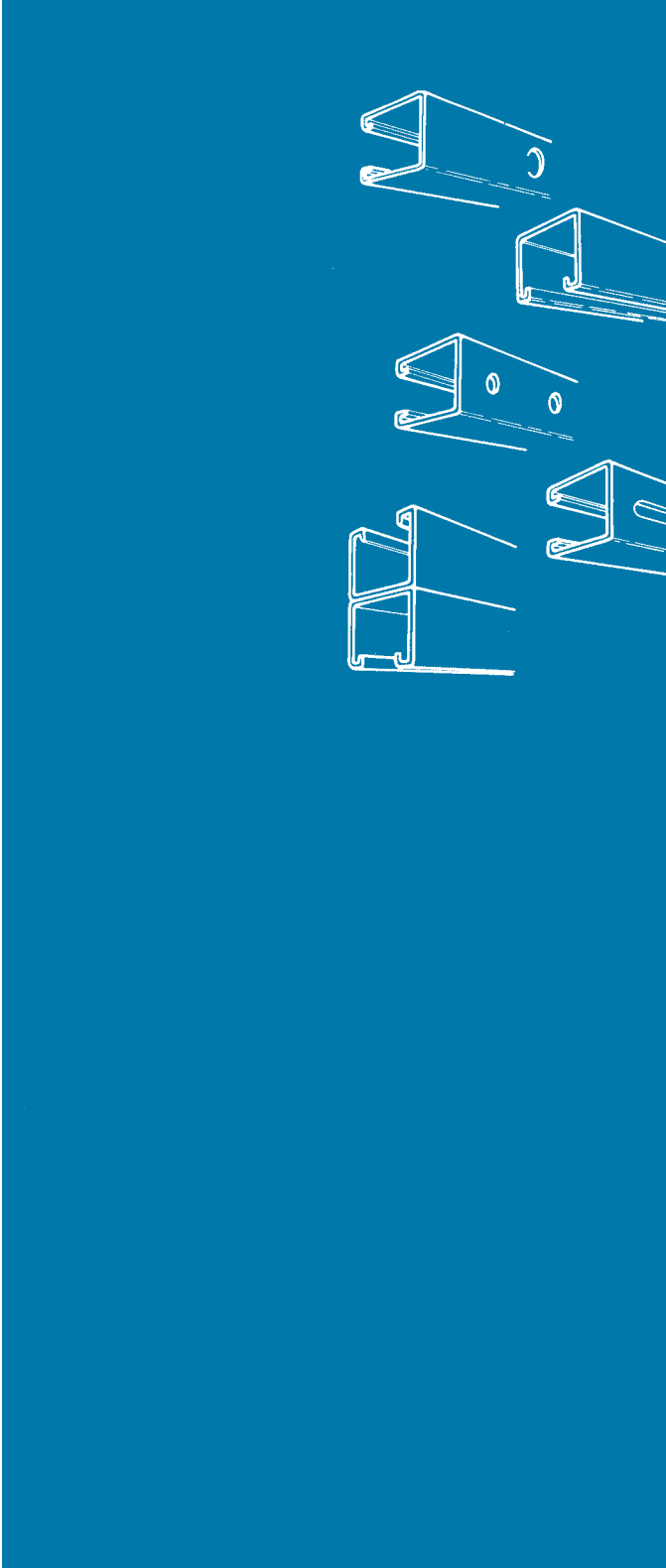

## SPECIFICATIONS

### GENERAL

Following is a numerical listing of Multi-Strut part numbers separated by classification, and listing the page number on which the part number is located.

# TECHNICAL SECTION

## REFERENCE DATA METRIC CONVERSION CHART

	TO CONVERT FROM	TO	MULTIPLY BY
<b>Angle</b>	degree	radian (rad)	$1.745329 \times 10^{-2}$
	radian (rad)	degree	$5.729578 \times 10^{-1}$
<b>Area</b>	foot <sup>2</sup>	square meter (m <sup>2</sup> )	$9.290304 \times 10^{-2}$
	inch <sup>2</sup>	square meter (m <sup>2</sup> )	$6.451600 \times 10^{-4}$
	circular mil	square meter (m <sup>2</sup> )	$5.067075 \times 10^{-10}$
	square centimeter (cm <sup>2</sup> )	square inch (in <sup>2</sup> )	$1.550003 \times 10^{-1}$
	square meter (m <sup>2</sup> )	foot <sup>2</sup>	$1.076391 \times 10^{-1}$
	square meter (m <sup>2</sup> )	inch <sup>2</sup>	$1.550003 \times 10^{-3}$
	square meter (m <sup>2</sup> )	circular mil	$1.973525 \times 10^{-9}$
<b>Bending Moment of Torque</b>	lbf•ft	newton meter (N•m)	1.355818
	lbf•in	newton meter (N•m)	$1.129848 \times 10^{-1}$
	N•m	lbf•ft	$7.375621 \times 10^{-1}$
	N•m	lbf•in	8.850748
<b>Force</b>	pounds-force (lbf)	newtons (N)	4.448222
<b>Length</b>	foot (ft)	meter (m)	$3.048000 \times 10^{-1}$
	inch (in)	meter (m)	$2.540000 \times 10^{-2}$
	mil	meter (m)	$2.540000 \times 10^{-5}$
	inch (in)	micrometer (µm)	$2.540000 \times 10^{-4}$
	meter (m)	foot (ft)	3.280840
	meter (m)	inch (in)	$3.937008 \times 10^{-1}$
	meter (m)	mil	$3.937008 \times 10^{-4}$
	micrometer (µm)	Inch (in)	$3.937008 \times 10^{-5}$
<b>Mass</b>	ounce (avoirdupois)	kilogram (kg)	$2.834952 \times 10^{-2}$
	pound (avoirdupois)	kilogram (kg)	$4.535924 \times 10^{-1}$
	ton (short, 2000 lb)	kilogram (kg)	$9.071847 \times 10^{-2}$
	ton (long, 2240 lb)	kilogram (kg)	$1.016047 \times 10^{-3}$
	kilogram (kg)	ounce (avoirdupois)	$3.527396 \times 10^{-1}$
	kilogram (kg)	pound (avoirdupois)	2.204622
	kilogram (kg)	ton (short 2000 lb)	$1.102311 \times 10^{-3}$
	kilogram (kg)	ton (long 2240 lb)	$9.842064 \times 10^{-4}$
<b>Mass Per Unit Length</b>	lb/ft	kilogram per meter (kg/m)	1.488164
	lb/in	kilogram per meter (kg/m)	$1.787597 \times 10^{-1}$
	kg/m	lb/ft	$6.719689 \times 10^{-1}$
	kg/m	lb/in	$5.599741 \times 10^{-2}$
<b>Mass Per Unit Volume</b>	lb/ft <sup>3</sup>	kilogram per cubic meter (kg/m <sup>3</sup> )	$1.601846 \times 10^{-1}$
	lb/in <sup>3</sup>	kilogram per cubic meter (kg/m <sup>3</sup> )	$2.767990 \times 10^{-4}$
	kg/m <sup>3</sup>	lb/ft <sup>3</sup>	$6.242797 \times 10^{-2}$
	kg/m <sup>3</sup>	lb/in <sup>3</sup>	$3.612730 \times 10^{-5}$
	lbs/ft <sup>3</sup>	lbs/in <sup>3</sup>	$1.728000 \times 10^{-3}$
<b>Mass Per Area Unit</b>	lb/ft <sup>2</sup>	kilogram per square meter (kg/m <sup>2</sup> )	4882428
	kg/m <sup>2</sup>	pound per square foot (lb/ft <sup>2</sup> )	$2.048161 \times 10^{-1}$
<b>Pressure or Stress</b>	lbf/in <sup>2</sup> (psi)	pascal (Pa)	$6.894757 \times 10^{-3}$
	kip/in <sup>2</sup> (ksi)	pascal (Pa)	$6.894757 \times 10^{-6}$
	lbf/in <sup>2</sup> (psi)	megapascals (MPa)	$6.894757 \times 10^{-3}$
	pascal (Pa)	pound force per sq. inch (psi)	$1.450377 \times 10^{-4}$
	pascal (Pa)	kip per sq. inch (ksi)	$1.450377 \times 10^{-7}$
	megapascals (MPa)	lbf/in <sup>2</sup> (psi)	$1.450377 \times 10^{-2}$
<b>Section Properties</b>	section modulus S (in <sup>3</sup> )	S (m <sup>3</sup> )	$1.638706 \times 10^{-6}$
	section modulus S (in <sup>3</sup> )	S (in <sup>3</sup> )	$6.102374 \times 10^{-4}$
	moment of inertia I (in <sup>4</sup> )	I (m <sup>4</sup> )	$4.162314 \times 10^{-7}$
	moment of inertia I (in <sup>4</sup> )	I (in <sup>4</sup> )	$2.402510 \times 10^{-6}$
	modulus of elasticity E (psi)	E (Pa)	$6.894757 \times 10^{-3}$
	modulus of elasticity E (Pa)	E (psi)	$1.450377 \times 10^{-4}$
<b>Temperature</b>	degree Fahrenheit	degree Celsius	$t^{\circ}C = (t^{\circ}F - 32) / 1.8$
	degree Celsius	degree Fahrenheit	$t^{\circ}F = 1.8 t^{\circ}C + 32$
<b>Volume</b>	foot <sup>3</sup>	cubic meter (m <sup>3</sup> )	$2.831685 \times 10^{-2}$
	inch <sup>3</sup>	cubic meter (m <sup>3</sup> )	$1.638706 \times 10^{-2}$
	cubic centimeter (cm <sup>3</sup> )	cubic inch (in <sup>3</sup> )	$6.102374 \times 10^{-2}$
	cubic meter (m <sup>3</sup> )	foot <sup>3</sup>	$3.531466 \times 10^{-1}$
	cubic meter (m <sup>3</sup> )	inch <sup>3</sup>	$6.102376 \times 10^{-4}$
	gallon (U.S. liquid)	cubic meter (m <sup>3</sup> )	$3.785412 \times 10^{-3}$

### ABBREVIATIONS

AISC	= American Institute of Steel Construction
AISI	= American Iron & Steel Institute
ASME	= American Society of Mechanical Engineers
ASTM	= American Society for Testing & Materials
AWWA	= American Water Works Association
Dia.	= Diameter
Ft.	= Feet
Ga	= Gauge
I.D.	= Inside Diameter
In.	= Inch
Lbs.	= Pounds
Max.	= Maximum
Min.	= Minimum
MSS	= Manufacturers' Standardization Society
NFPA	= National Fire Protection Association
O.D.	= Outside Diameter
Oz.	= Ounces
psi	= Pounds Per Square Inch
PVC	= Poly Vinyl Chloride
UNC	= Unified Course Threads
UNCR	= Unified Course Threads (Rounded Root)

### METRIC SYMBOLS

cm	= centimeter
kg	= kilogram
kN	= kilonewton
m	= meter
µm	= micrometer
mm	= millimeter
MPa	= megapascal
N	= newton
Nm	= newton-meter
Pa	= pascal

# TECHNICAL SECTION PIPE WEIGHTS FOR STANDARD AND HEAVY WEIGHT PIPE

PIPE DATA					PIPE WEIGHT			
Nominal	Pipe	Outside Dia.		Wall Th'k	w/ Gas, Air, Steam		w/ Water	
Pipe Size	Schedule	in	mm	in	lbs/ft	N/m	lbs/ft	N/m
1/2"	Std / 40	0.840	22	0.109	0.9	12	1.0	14
(15mm)	XS / 80			0.147	1.1	16	1.2	17
3/4"	Std / 40	1.050	28	0.113	1.1	17	1.4	20
(20mm)	XS / 80			0.154	1.5	22	1.7	24
1"	Std / 40	1.315	34	0.133	1.7	25	2.1	30
(25mm)	XS / 80			0.179	2.2	32	2.5	36
1 1/4"	Std / 40	1.660	42	0.140	2.3	33	2.9	43
(32mm)	XS / 80			0.191	3.0	44	3.6	52
1 1/2"	Std / 40	1.900	48	0.145	2.7	40	3.6	53
(40mm)	XS / 80			0.200	3.6	53	4.4	64
2"	Std / 40	2.375	60	0.154	3.7	53	5.1	75
(50mm)	XS / 80			0.218	5.0	73	6.3	92
2 1/2"	Std / 40	2.875	75	0.203	5.8	85	7.9	115
(65mm)	XS / 80			0.276	7.7	112	9.5	139
3"	Std / 40	3.500	89	0.216	7.6	111	11	157
(80mm)	XS / 80			0.300	10	150	13	191
3 1/2"	Std / 40	4.000	102	0.226	9.1	133	13	195
(90mm)	XS / 80			0.318	13	182	16	239
4"	Std / 40	4.500	114	0.237	11	157	16	238
(100mm)	XS / 80			0.337	15	219	20	291
5"	Std / 40	5.563	141	0.258	15	213	23	340
(125mm)	XS / 80			0.375	21	303	29	418
6"	Std / 40	6.625	168	0.280	19	277	31	460
(150mm)	XS / 80			0.432	29	417	40	582
8"	Std / 40	8.625	219	0.322	29	417	50	733
(200mm)	XS / 80			0.500	43	633	63	922
10"	Std / 40	10.75	273	0.365	40	591	75	1090
(250mm)	XS / 60			0.500	55	799	87	1271
12"	Std	12.75	235	0.375	50	723	99	1439
(300mm)	XS			0.500	65	955	112	1641
14"	Std / 30	14.00	355.6	0.375	55	796	114	1669
(350mm)	XS			0.500	72	1052	130	1892
16"	Std / 30	16.00	406.4	0.375	63	913	142	2069
(400mm)	XS / 40			0.500	83	1208	159	2326
18"	Std	18.00	457.2	0.375	71	1030	172	2509
(450mm)	XS			0.500	93	1364	192	2800
20"	Std / 20	20.00	508.0	0.375	79	1147	205	2988
(500mm)	XS / 30			0.500	104	1520	227	3313
24"	Std / 20	24.00	609.6	0.375	95	1381	279	4067
(600mm)	XS			0.500	125	1831	306	4460
30"	Std	30.00	762.0	0.375	119	1731	410	5983
(750mm)	XS / 20			0.500	158	2299	444	6478
36"	Std	36.00	914.4	0.375	143	2082	566	8256
(900mm)	XS / 20			0.500	190	2766	607	8853
42"	Std	42.00	1066.8	0.375	167	2433	746	10888
(1050mm)	XS / 20			0.500	222	3234	794	11587

Pipe Weights are based on Carbon Steel pipe



# TECHNICAL SECTION COPPER TUBING DATA

## TYPE L

NOMINAL TUBING SIZE		O.D. SIZE		WALL THICKNESS		WEIGHT OF TUBING		WEIGHT OF TUBING FILLED WITH WATER	
in.	mm	in.	mm	in.	mm	Lbs./Ft.	Kg/m	Lbs./Ft.	Kg/m
1/4	8	0.375	9.5	0.030	0.8	0.13	0.19	0.15	0.22
3/8	10	0.500	12.7	0.035	0.9	0.20	0.29	0.26	0.39
1/2	15	0.625	15.9	0.040	1.0	0.29	0.42	0.38	0.57
5/8	18	0.750	19.1	0.042	1.1	0.36	0.54	0.51	0.76
3/4	20	0.875	22.2	0.045	1.1	0.46	0.68	0.66	0.98
1	25	1.125	28.6	0.050	1.3	0.66	0.97	1.01	1.50
1 1/4	32	1.375	34.9	0.055	1.4	0.88	1.32	1.42	2.11
1 1/2	40	1.625	41.3	0.060	1.5	1.14	1.70	1.91	2.84
2	50	2.125	54.0	0.070	1.8	1.75	2.60	3.09	4.60
2 1/2	65	2.625	66.7	0.080	2.0	2.48	3.69	4.54	6.76
3	80	3.125	79.4	0.090	2.3	3.33	4.96	6.28	9.35
3 1/2	90	3.625	92.1	0.100	2.5	4.29	6.38	8.28	12.32
4	100	4.125	104.8	0.110	2.8	5.38	8.01	10.57	15.73
5	125	5.125	130.2	0.125	3.2	7.61	11.30	15.69	23.35
6	150	6.125	155.6	0.140	3.6	10.20	15.20	21.81	32.46
8	200	8.125	206.4	0.200	5.1	19.26	28.70	39.49	58.77
10	250	10.125	257.2	0.250	6.4	20.10	29.90	61.69	91.81
12	300	12.125	308.0	0.280	7.1	40.40	60.10	85.83	127.73

## TYPE K

NOMINAL TUBING SIZE		O.D. SIZE		WALL THICKNESS		WEIGHT OF TUBING		WEIGHT OF TUBING FILLED WITH WATER	
in.	mm	in.	mm	in.	mm	Lbs./Ft.	Kg/m	Lbs./Ft.	Kg/m
1/4	8	0.375	9.5	0.035	0.9	0.14	0.21	0.17	0.25
3/8	10	0.500	12.7	0.049	1.2	0.27	0.40	0.32	0.48
1/2	15	0.625	15.9	0.049	1.2	0.34	0.51	0.43	0.64
5/8	18	0.750	19.1	0.049	1.2	0.42	0.63	0.56	0.83
3/4	20	0.875	22.2	0.065	1.7	0.64	0.95	0.83	1.24
1	25	1.125	28.6	0.065	1.7	0.84	1.25	1.18	1.76
1 1/4	32	1.375	34.9	0.065	1.7	1.04	1.55	1.57	2.34
1 1/2	40	1.625	41.3	0.072	1.8	1.36	2.02	2.10	3.13
2	50	2.125	54.0	0.083	2.1	2.06	3.07	3.37	5.02
2 1/2	65	2.625	66.7	0.095	2.4	2.92	4.35	4.92	7.32
3	80	3.125	79.4	0.109	2.8	4.00	5.95	6.96	10.36
3 1/2	90	3.625	92.1	0.120	3.0	5.12	7.62	9.02	13.42
4	100	4.125	104.8	0.134	3.4	6.51	9.69	11.57	17.22
5	125	5.125	130.2	0.160	4.1	9.67	14.4	17.67	26.30
6	150	6.125	155.6	0.192	4.9	13.87	20.6	25.07	37.31
8	200	8.125	206.4	0.271	6.9	25.90	38.5	45.40	67.56
10	250	10.125	257.2	0.338	8.6	40.30	60.0	70.72	105.25
12	300	12.125	308.0	0.405	10.3	57.80	86.0	101.48	151.02

# TECHNICAL SECTION

## PIPE WEIGHTS FOR PVC AND CPVC PIPE – TYPES I & II

PIPE DATA					PVC PIPE WEIGHT				CPVC PIPE WEIGHT			
Nominal Pipe Size	Pipe Schedule	Outside Dia.		Wall Th'k	w/ Gas, Air		w/ Water		w/ Gas, Air		w/ Water	
		in	mm		lbs/ft	N/m	lbs/ft	N/m	lbs/ft	N/m	lbs/ft	N/m
1/8" (3mm)	40	0.405	10	0.068	0.05	0.7	0.07	1.0				
	80			0.095	0.06	0.9	0.08	1.1				
1/4" (6mm)	40	0.54	14	0.088	0.08	1.2	0.13	1.9	0.09	1.3	0.13	2.0
	80			0.119	0.10	1.5	0.13	2.0	0.12	1.7	0.14	2.1
3/8" (10mm)	40	0.675	17	0.091	0.11	1.6	0.19	2.8	0.12	1.8	0.20	3.0
	80			0.126	0.14	2.1	0.20	3.0	0.16	2.3	0.22	3.2
1/2" (15mm)	40	0.840	22	0.109	0.17	2.4	0.30	4.4	0.19	2.7	0.31	4.6
	80			0.147	0.21	3.1	0.31	4.6	0.24	3.5	0.33	4.8
	120			0.170	0.24	3.4	0.32	4.7				
3/4" (20mm)	40	1.050	28	0.113	0.22	3.2	0.45	6.6	0.25	3.6	0.47	6.9
	80			0.154	0.29	4.2	0.47	6.9	0.32	4.7	0.50	7.3
	120			0.170	0.31	4.5	0.48	7.0				
1" (25mm)	40	1.315	34	0.133	0.33	4.8	0.70	10	0.37	5.4	0.73	11
	80			0.179	0.42	6.2	0.74	11	0.47	6.9	0.77	11
	120			0.200	0.46	6.8	0.75	11				
1 1/4" (32mm)	40	1.660	42	0.140	0.44	6.5	1.1	16	0.50	7.2	1.1	16
	80			0.191	0.58	8.5	1.1	17	0.65	9.5	1.2	17
	120			0.215	0.65	9.5	1.2	17				
1 1/2" (40mm)	40	1.900	48	0.145	0.53	7.8	1.4	21	0.60	8.7	1.5	21
	80			0.200	0.71	10	1.5	22	0.79	12	1.5	22
	120			0.225	0.79	11	1.5	22				
2" (50mm)	40	2.375	60	0.154	0.72	10	2.2	32	0.80	12	2.2	33
	80			0.218	0.98	14	2.3	33	1.1	16	2.3	34
	120			0.250	1.1	16	2.3	34				
2 1/2" (65mm)	40	2.875	75	0.203	1.1	17	3.2	47	1.3	18	3.3	48
	80			0.276	1.5	22	3.3	49	1.7	24	3.5	50
	120			0.300	1.6	24	3.4	49				
3" (80mm)	40	3.500	89	0.216	1.5	22	4.7	68	1.7	24	4.8	70
	80			0.300	2.0	29	4.9	71	2.2	33	5.0	73
	120			0.350	2.3	34	5.0	73				
3 1/2" (90mm)	40	4.000	102	0.226	1.8	26	6.1	89	2.0	29	6.2	91
	80			0.318	2.5	36	6.3	92	2.7	40	6.5	95
4" (100mm)	40	4.500	114	0.237	2.1	31	7.6	111	2.4	34	7.8	114
	80			0.337	2.9	43	7.9	116	3.3	48	8.2	119
	120			0.437	3.7	54	8.2	120				
5" (125mm)	40	5.563	141	0.258	2.9	42	12	168				
	80			0.375	4.1	60	12	175				
6" (150mm)	40	6.625	168	0.280	3.7	54	16	237	4.2	61	17	242
	80			0.432	5.6	82	17	247	6.3	91	17	253
	120			0.562	7.1	104	17	254				
8" (200mm)	40	8.625	219	0.322	5.6	82	27	398	6.3	91	28	405
	80			0.500	8.5	124	28	413	9.5	139	29	423
10" (250mm)	40	10.75	273	0.365	8.0	116	42	615	8.9	130	43	624
	80			0.593	13	184	44	639	14	206	45	654
12" (300mm)	40	12.75	235	0.406	11	153	59	862	12	171	60	874
	80			0.687	17	254	61	897	19	283	63	917
14" (350mm)	40	14.00	355.6	0.437	12	182	71	1038				
	80			0.750	21	304	74	1081				
16" (400mm)	40	16.00	406.4	0.500	16	238	93	1356				
	80			0.843	27	391	97	1409				
18" (450mm)	40	18.00	457.2	0.562	22	328	119	1743				
	80			0.937	34	489	122	1781				
20" (500mm)	40	20.00	508.0	0.593	27	388	147	2146				
	80			1.031	42	618	152	2217				
24" (600mm)	40	24.00	609.6	0.687	37	542	211	3086				
	80			1.218	60	879	219	3189				

PVC and CPVC pipe weights are based on the "average I.D."

# TECHNICAL SECTION HANGER SPACING FOR PVC AND CPVC PIPING

Pipe		PVC										CPVC											
		60° F		80° F		100° F		120° F		140° F		73° F		100° F		120° F		140° F		160° F		180° F	
Size	Sch.	ft	mm	ft	mm	ft	mm	ft	mm	ft	mm	ft	mm	ft	mm	ft	mm	ft	mm	ft	mm	ft	mm
1/2" 15mm	40	4.5	1.37	4.5	1.37	4.0	1.22	2.5	0.76	2.5	0.76	5.0	1.52	4.5	1.37	4.5	1.37	4.0	1.22	2.5	0.76	2.5	0.76
	80	5.0	1.52	4.5	1.37	4.5	1.37	3.0	0.91	2.5	0.76	5.5	1.68	5.5	1.68	4.5	1.37	4.5	1.37	3.0	0.91	2.5	0.76
	120	5.0	1.52	5.0	1.52	4.5	1.37	3.0	0.91	2.5	0.76												
3/4" 20mm	40	5.0	1.52	4.5	1.37	4.0	1.22	2.5	0.76	2.5	0.76	5.0	1.52	5.0	1.52	4.5	1.37	4.0	1.22	2.5	0.76	2.5	0.76
	80	5.5	1.68	5.0	1.52	4.5	1.37	3.0	0.91	2.5	0.76	5.5	1.68	5.5	1.68	5.0	1.52	4.5	1.37	3.0	0.91	2.5	0.76
	120	5.5	1.68	5.0	1.52	4.5	1.37	3.0	0.91	3.0	0.91												
1" 25mm	40	5.5	1.68	5.0	1.52	4.5	1.37	3.0	0.91	2.5	0.76	5.5	1.68	5.5	1.68	5.0	1.52	4.5	1.37	3.0	0.91	2.5	0.76
	80	6.0	1.83	5.5	1.68	5.0	1.52	3.5	1.07	3.0	0.91	6.0	1.83	6.0	1.83	5.5	1.68	5.0	1.52	3.5	1.07	3.0	0.91
	120	6.0	1.83	5.5	1.68	5.0	1.52	3.5	1.07	3.0	0.91												
1 1/4" 32mm	40	5.5	1.68	5.5	1.68	5.0	1.52	3.0	0.91	3.0	0.91	5.5	1.68	5.5	1.68	5.5	1.68	5.0	1.52	3.0	0.91	3.0	0.91
	80	6.0	1.83	6.0	1.83	5.5	1.68	3.5	1.07	3.0	0.91	6.5	1.98	6.0	1.83	6.0	1.83	5.5	1.68	3.5	1.07	3.0	0.91
	120	6.5	1.98	6.0	1.83	5.5	1.68	3.5	1.07	3.5	1.07												
1 1/2" 40mm	40	6.0	1.83	5.5	1.68	5.0	1.52	3.5	1.07	3.0	0.91	6.0	1.83	6.0	1.83	5.5	1.68	5.0	1.52	3.5	1.07	3.0	0.91
	80	6.5	1.98	6.0	1.83	5.5	1.68	3.5	1.07	3.5	1.07	7.0	2.13	6.5	1.98	6.0	1.83	5.5	1.68	3.5	1.07	3.5	1.07
	120	6.5	1.98	6.5	1.98	6.0	1.83	4.0	1.22	3.5	1.07												
2" 50mm	40	6.0	1.83	5.5	1.68	5.0	1.52	3.5	1.07	3.0	0.91	6.0	1.83	6.0	1.83	5.5	1.68	5.0	1.52	3.5	1.07	3.0	0.91
	80	7.0	2.13	6.5	1.98	6.0	1.83	4.0	1.22	3.5	1.07	7.0	2.13	7.0	2.13	6.5	1.98	6.0	1.83	4.0	1.22	3.5	1.07
	120	7.5	2.29	7.0	2.13	6.5	1.98	4.0	1.22	3.5	1.07												
2 1/2" 65mm	40	7.0	2.13	6.5	1.98	6.0	1.83	4.0	1.22	3.5	1.07	7.0	2.13	7.0	2.13	6.5	1.98	6.0	1.83	4.0	1.22	3.5	1.07
	80	7.5	2.29	7.5	2.29	6.5	1.98	4.5	1.37	4.0	1.22	8.0	2.44	7.5	2.29	7.5	2.29	6.5	1.98	4.5	1.37	4.0	1.22
	120	8.0	2.44	7.5	2.29	7.0	2.13	4.5	1.37	4.0	1.22												
3" 80mm	40	7.0	2.13	7.0	2.13	6.0	1.83	4.0	1.22	3.5	1.07	7.0	2.13	7.0	2.13	7.0	2.13	6.0	1.83	4.0	1.22	3.5	1.07
	80	8.0	2.44	7.5	2.29	7.0	2.13	4.5	1.37	4.0	1.22	8.0	2.44	8.0	2.44	7.5	2.29	7.0	2.13	4.5	1.37	4.0	1.22
	120	8.5	2.59	8.0	2.44	7.5	2.29	5.0	1.52	4.5	1.37												
3 1/2" 90mm	40	7.5	2.29	7.0	2.13	6.5	1.98	4.0	1.22	4.0	1.22	7.5	2.29	7.5	2.29	7.0	2.13	6.5	1.98	4.0	1.22	4.0	1.22
	80	8.5	2.59	8.0	2.44	7.5	2.29	5.0	1.52	4.5	1.37	8.5	2.59	8.5	2.59	8.0	2.44	7.5	2.29	5.0	1.52	4.5	1.37
	120	9.0	2.74	8.5	2.59	8.0	2.44	5.5	1.68	5.0	1.52												
4" 100mm	40	7.5	2.29	7.0	2.13	6.5	1.98	4.5	1.37	4.0	1.22	7.5	2.29	7.5	2.29	7.0	2.13	6.5	1.98	4.5	1.37	4.0	1.22
	80	9.0	2.74	8.5	2.59	7.5	2.29	5.0	1.52	4.5	1.37	8.5	2.59	9.0	2.74	8.5	2.59	7.5	2.29	5.0	1.52	4.5	1.37
	120	9.5	2.90	9.0	2.74	8.5	2.59	5.5	1.68	5.0	1.52												
5" 125mm	40	8.0	2.44	7.5	2.29	7.0	2.13	4.5	1.37	4.0	1.22	8.0	2.44	8.0	2.44	7.5	2.29	7.0	2.13	5.0	1.52	4.5	1.37
	80	9.5	2.90	9.0	2.74	8.0	2.44	5.5	1.68	5.0	1.52	9.0	2.74	9.0	2.74	8.5	2.59	8.0	2.44	5.5	1.68	5.0	1.52
	120	10.0	3.05	9.0	2.74	8.5	2.59	5.5	1.68	5.0	1.52												
6" 150mm	40	8.5	2.59	8.0	2.44	7.5	2.29	5.0	1.52	4.5	1.37	8.5	2.59	8.0	2.44	7.5	2.29	7.0	2.13	5.0	1.52	4.5	1.37
	80	10.0	3.05	9.5	2.90	9.0	2.74	6.0	1.83	5.0	1.52	10.0	3.05	9.5	2.90	9.0	2.74	8.0	2.44	5.5	1.68	5.0	1.52
	120	11.5	3.51	10.5	3.20	9.5	2.90	6.5	1.98	6.0	1.83												
8" 200mm	40	9.0	2.74	8.5	2.59	8.0	2.44	5.0	1.52	4.5	1.37	9.5	2.90	9.0	2.74	8.5	2.59	7.5	2.29	5.5	1.68	5.0	1.52
	80	11.0	3.35	10.5	3.20	9.5	2.90	6.5	1.98	5.5	1.68	11.0	3.35	10.5	3.20	10.0	3.05	9.0	2.74	6.0	1.83	5.5	1.68
	120	12.0	3.66	11.0	3.35	10.0	3.05	7.0	2.13	6.0	1.83												
10" 250mm	40	10.0	3.05	9.0	2.74	8.5	2.59	5.5	1.68	5.0	1.52	10.5	3.20	10.0	3.05	9.5	2.90	8.0	2.44	6.0	1.83	0.56	0.17
	80	12.0	3.66	11.0	3.35	10.0	3.05	7.0	2.13	6.0	1.83	11.5	3.51	11.0	3.35	10.5	3.20	9.5	2.90	6.5	1.98	0.60	0.18
	120	13.0	3.96	12.0	3.66	10.5	3.20	7.5	2.29	6.5	1.98												
12" 300mm	40	11.5	3.51	10.5	3.20	9.5	2.90	6.5	1.98	5.5	1.68	11.5	3.51	10.5	3.20	10.0	3.05	8.5	2.59	6.5	1.98	6.0	1.83
	80	13.0	3.96	12.0	3.66	10.5	3.20	7.5	2.29	6.5	1.98	12.5	3.81	12.0	3.66	11.5	3.51	10.5	3.20	7.5	2.29	6.5	1.98
	120	14.0	4.27	13.0	3.96	11.0	3.35	8.0	2.44	7.0	2.13												
14" 350mm	40	12.0	3.66	11.0	3.35	10.0	3.05	7.0	2.13	6.0	1.83												
	80	13.5	4.11	13.0	3.96	11.0	3.35	8.0	2.44	7.0	2.13												
	120	14.0	4.27	13.5	4.11	11.5	3.51	8.5	2.59	7.5	2.29												
16" 400mm	40	12.5	3.81	11.5	3.51	10.5	3.20	7.5	2.29	6.5	1.98												
	80	14.0	4.27	13.5	4.11	11.5	3.51	8.5	2.59	7.5	2.29												
	120	14.5	4.42	14.0	4.27	12.0	3.66	9.0	2.74	8.0	2.44												
18" 450mm	40	13.0	3.96	12.0	3.66	11.0	3.35	8.0	2.44	7.0	2.13												
	80	14.5	4.42	14.0	4.27	12.0	3.66	9.0	2.74	8.0	2.44												
	120	15.0	4.57	14.5	4.42	12.5	3.81	9.5	2.90	8.5	2.59												
20" 500mm	40	13.5	4.11	12.5	3.81	11.5	3.51	8.5	2.59	7.5	2.29												
	80	15.0	4.57	14.5	4.42	12.5	3.81	9.5	2.90	8.5	2.59												
	120	15.5	4.72	15.0	4.57	13.0	3.96	10.0	3.05	9.0	2.74												
24" 600mm	40	14.0	4.27	13.																			

## MAXIMUM HORIZONTAL HANGER SPACING

PER MSS-SP69, AND ASME B31.1

NOMINAL PIPE SIZE OR TUBE DIA.	STANDARD WEIGHT STEEL PIPE SERVICE (FEET / METERS)		COPPER TUBING SERVICE (FEET / METERS)	
	WATER	VAPOR	WATER	VAPOR
	1/4	7	8	5
8	2.13	2.44	1.52	1.52
3/8	7	8	5	6
10	2.13	2.44	1.52	1.83
1/2	7	8	5	6
15	2.13	2.44	1.52	1.83
3/4	7	9	5	7
20	2.13	2.74	1.52	2.13
1	7	9	6	8
25	2.13	2.74	1.83	2.44
1 1/4	7	9	7	9
32	2.13	2.74	2.13	2.74
1 1/2	9	12	8	10
40	2.74	3.66	2.44	3.05
2	10	13	8	11
50	3.05	3.96	2.44	3.35
2 1/2	11	14	9	13
65	3.35	4.27	2.74	3.96
3	12	15	10	14
80	3.66	4.57	3.05	4.27
3 1/2	13	16	11	15
90	3.96	4.88	3.35	4.57
4	14	17	12	16
100	4.27	5.18	3.66	4.88
5	16	19	13	18
125	4.88	5.79	3.96	5.49
6	17	21	14	20
150	5.18	6.40	4.27	6.10
8	19	24	16	23
200	5.79	7.32	4.88	7.01
10	22	26	18	25
250	6.71	7.92	5.49	7.62
12	23	30	19	28
300	7.01	9.14	5.79	8.53
14	25	32		
350	7.62	9.75		
16	27	35		
400	8.23	10.67		
18	28	37		
450	8.53	11.28		
20	30	39		
500	9.14	11.89		
24	32	42		
600	9.75	12.80		
30	33	44		
750	10.06	13.41		

## LOAD CHART FOR THREADED ROD

MATERIALS: ASTM A36, A575 GR. 1020 OR A576 GR 1020

NOMINAL ROD DIAMETER	MAXIMUM SAFE ROD LOAD ROD TEMPERATURE		WEIGHT PER FOOT METER	ROOT AREA IN. <sup>2</sup> MM <sup>2</sup>
	650°F 349°C	750°F 399°C		
	1/4	240		
M6	1068	934	0.248	0.017
3/8	610	540	0.360	0.068
M10	2714	2402	0.536	0.044
1/2	1130	1010	0.668	0.126
M12	5027	4493	0.994	0.081
5/8	1810	1610	1.04	0.202
M16	8052	7162	1.55	0.130
3/4	2710	2420	1.50	0.302
M20	12055	10765	2.23	0.195
7/8	3770	3360	2.04	0.419
M20	16770	14947	3.04	0.270
1	4960	4420	2.67	0.552
M24	22064	19662	3.97	0.356
1 1/4	8000	7140	3.38	0.889
M30	35587	31762	5.03	0.574
1 1/2	11630	10370	4.17	1.293
M36	51735	46130	6.20	0.834
1 3/4	15700	14000	6.01	1.744
M42	69840	62278	8.94	1.125
2	20700	18460	8.18	2.300
M48	92082	82117	12.17	1.484
2 1/4	27200	24260	10.68	3.023
M56	120996	107918	15.89	1.950
2 1/2	33500	29880	13.52	3.716
M64	149021	132918	20.12	2.398
2 3/4	41580	37066	16.69	4.619
M72	184964	164884	24.83	2.980
3	50580	45085	20.19	5.621
M80	225000	200556	30.04	3.627

## GAUGE THICKNESS

GAUGE	MINIMUM	NOMINAL
3	0.215	0.239
3	5.461	6.071
7	0.167	0.179
7	4.242	4.547
11	0.108	0.120
11	2.743	3.048
12	0.093	0.105
12	2.362	2.667
13	0.080	0.090
13	2.032	2.286
14	0.066	0.075
14	1.676	1.905
16	0.053	0.060
16	1.346	1.524
18	0.042	0.048
18	1.067	1.219

# TECHNICAL SECTION COMMON STRUCTURAL SHAPES USED FOR PIPE SUPPORTS

STRUCTURAL SHAPE	SIZE	WEIGHT PER FOOT	DEPTH IN	FLANGE WIDTH IN	THICKNESS IN	SECTION MODULUS IN <sup>3</sup>
ANGLE	L 1 1/2 x 1 1/2 x 1/4	2.3	1 1/2	1 1/2	1/4	0.13
	L 2 x 2 x 1/4	3.2	2	2	1/4	0.25
	L 2 1/2 x 2 1/2 x 1/4	4.1	2 1/2	2 1/2	1/4	0.38
	L 3 x 3 x 1/4	4.9	3	3	1/4	0.58
	L 3 x 3 x 3/8	7.2	3	3	3/8	0.83
	L 3 x 3 x 1/2	9.4	3	3	1/2	1.07
	L 3 1/2 x 3 1/2 x 3/8	8.5	3 1/2	3 1/2	3/8	1.15
	L 4 x 4 x 3/8	9.8	4	4	3/8	1.52
	L 4 x 4 x 1/2	12.8	4	4	1/2	1.97
	L 5 x 5 x 1/2	16.2	5	5	1/2	3.16
	L 6 x 6 x 1/2	19.6	6	6	1/2	4.61
	L 6 x 6 x 3/4	28.7	6	6	3/4	6.66
CHANNEL	C 3 x 4.1	4.1	3	1 3/8	1/4	1.10
	C 4 x 5.4	5.4	4	1 5/8	5/16	1.93
	C 5 x 6.7	6.7	5	1 3/4	5/16	3.00
	C 6 x 8.2	8.2	6	1 7/8	5/16	4.38
	C 8 x 11.5	11.5	8	2 1/4	3/8	8.14
	C 10 x 15.3	15.3	10	2 5/8	7/16	13.50
	C 12 x 20.7	20.7	12	3	1/2	21.50
	C 15 x 33.9	33.9	15	3 3/8	3/8	42.00
SQUARE TUBING	ST 2 x 2 x 1/4	5.4	2	2	1/4	0.77
	ST 3 x 3 x 1/4	8.8	3	3	1/4	2.10
	ST 4 x 4 x 1/4	12.2	4	4	1/4	4.11
	ST 4 x 4 x 3/8	17.3	4	4	3/8	5.35
	ST 4 x 4 x 1/2	21.6	4	4	1/2	6.13
	ST 6 x 6 x 1/4	19.0	6	6	1/4	10.10
	ST 6 x 6 x 3/8	27.5	6	6	3/8	13.90
	ST 6 x 6 x 1/2	35.2	6	6	1/2	16.80
	ST 8 x 8 x 1/4	25.8	8	8	1/4	18.80
	ST 8 x 8 x 3/8	38.9	8	8	3/8	26.40
ST 8 x 8 x 1/2	48.9	8	8	1/2	32.90	
I-BEAM	S 4 x 7.7	7.7	4	2 5/8	5/16	3.04
	W 4 x 13	13.0	4 1/8	4	3/8	5.46
	W 6 x 12	12.0	6	4	1/4	7.31
	W 6 x 15	15.0	6	6	1/4	9.72
	W 6 x 20	20.0	6 1/4	6	3/8	13.40
	W 8 x 18	18.0	8 1/8	5 1/4	5/16	15.20
	W 8 x 24	24.0	7 7/8	6 1/2	3/8	20.90
	W 8 x 31	31.0	8	8	7/16	27.50
	W 10 x 22	22.0	10 1/8	5 3/4	3/8	23.20
	W 10 x 33	33.0	9 3/4	8	7/16	35.00
	W 12 x 26	26.0	12 1/4	6 1/2	3/8	33.40
	W 12 x 40	40.0	12	8	1/2	51.90

Note: Flange thickness for I-Beam and Channel is the "mean" thickness

# INDEX

<b>CHANNEL</b>			
M-112 .....	Page 5	M-172-OS .....	Page 13
M-112-A .....	5	M-172-OS3 .....	13
M-112-KO .....	5	M-172-RS .....	13
M-112-OS .....	5		
M-112-OS3 .....	5	<b>GRIP LOCK NUTS</b>	
M-112-RS .....	5	N-800 .....	16
M-122 .....	6	N-801 .....	16
M-122-A .....	6	N-802 .....	16
M-122-KO .....	6	N-803 .....	16
M-122-OS .....	6	N-804 .....	16
M-122-OS3 .....	6	N-805 .....	16
M-122-RS .....	6	N-806 .....	16
M-132 .....	7	N-807 .....	16
M-132-A .....	7	N-808 .....	16
M-132-KO .....	7	N-809 .....	16
M-132-OS .....	7	N-810 .....	16
M-132-OS3 .....	7	N-811 .....	16
M-132-RS .....	7	N-812 .....	16
M-134 .....	8	N-814 .....	16
M-134-A .....	8	N-815 .....	16
M-134-KO .....	8	N-818 .....	16
M-134-OS .....	8	N-820 .....	16
M-134-OS3 .....	8	N-821 .....	16
M-134-RS .....	8	N-822 .....	16
M-142 .....	9	N-823 .....	16
M-142-A .....	9	N-824 .....	16
M-142-KO .....	9	N-825 .....	16
M-142-OS .....	9	N-828 .....	16
M-142-OS3 .....	9	N-829 .....	16
M-142-RS .....	9	N-830 .....	16
M-152 .....	10	N-831 .....	16
M-152-A .....	10	N-832 .....	16
M-152-KO .....	10	N-833 .....	16
M-152-OS .....	10	N-834 .....	16
M-152-OS3 .....	10	N-835 .....	16
M-152-RS .....	10	N-836 .....	16
M-164 .....	11	TSN-800 .....	16
M-164-A .....	11	TSN-801 .....	16
M-164-KO .....	11	TSN-802 .....	16
M-164-OS .....	11	TSN-808 .....	16
M-164-OS3 .....	11		
M-164-RS .....	11	<b>PIPE CLAMPS</b>	
M-165 .....	12	C100025 .....	20
M-165-A .....	12	C100037 .....	20
M-165-KO .....	12	C100050 .....	20
M-165-OS .....	12	C100062 .....	20
M-165-OS3 .....	12	C100075 .....	20
M-165-RS .....	12	C100087 .....	20
M-172 .....	13	C100100 .....	20
M-172-A .....	13	C100112 .....	20
M-172-KO .....	13	C100125 .....	20
		C100137 .....	20
		C100150 .....	20
		C100162 .....	20
		C100175 .....	Page 20
		C100187 .....	20
		C100200 .....	20
		C100212 .....	20
		C100237 .....	20
		C100262 .....	20
		C100300 .....	20
		C100312 .....	20
		C100362 .....	20
		C100412 .....	20
		C200025 .....	20
		C200037 .....	20
		C200050 .....	20
		C200075 .....	20
		C200100 .....	20
		C200125 .....	20
		C200150 .....	20
		C200200 .....	20
		C200250 .....	20
		C200300 .....	20
		C200350 .....	20
		C200400 .....	20
		C200500 .....	20
		C200600 .....	20
		C-1100-3/8 .....	21
		C-1100-1/2 .....	21
		C-1100-3/4 .....	21
		C-1100-1 .....	21
		C-1100-1-1/4 .....	21
		C-1100-1-1/2 .....	21
		C-1100-2 .....	21
		C-1101-1/4OD .....	22
		C-1101-3/8OD .....	22
		C-1101-1/2OD .....	22
		C-1101-5/8OD .....	22
		C-1101-3/4OD .....	22
		C-1101-7/8OD .....	22
		C-1101-1OD .....	22
		C-1101-1-1/8OD .....	22
		C-1101-1-1/4OD .....	22
		C-1101-1-3/8OD .....	22
		C-1101-1-1/2OD .....	22
		C-1101-1-5/8OD .....	22
		C-1101-1-3/4OD .....	22
		C-1101-1-7/8OD .....	22
		C-1101-2OD .....	22
		C-1101-2-1/8OD .....	22
		C-1101-2-1/4OD .....	22
		C-1101-2-3/8OD .....	22
		C-1101-2-1/2OD .....	22
		C-1101-2-5/8OD .....	22
		C-1101-2-3/4OD .....	22
		C-1101-2-7/8OD .....	22
		C-1101-3OD .....	22

# INDEX

C-1101-3-1/8OD .....Page 22	C-1101-5CT .....Page 22	C-1109-3/4 .....Page 23
C-1101-3-1/4OD .....22	C-1101-6CT .....22	C-1109-7/8 .....23
C-1101-3-3/8OD .....22	C-1101-8CT .....22	C-1109-1 .....23
C-1101-3-1/4OD .....22	C-1102-3/8 .....21	
C-1101-3-1/2OD .....22	C-1102-3/4 .....21	<b>FITTINGS- FLAT PLATES</b>
C-1101-3-5/8OD .....22	C-1102-1 .....21	F-201-5/16 .....25
C-1101-3-3/4OD .....22	C-1102-1-1/4 .....21	F-201-3/8 .....25
C-1101-3-7/8OD .....22	C-1102-1-1/2 .....21	F-201-1/2 .....25
C-1101-4OD .....22	C-1102-2 .....21	F-201-5/8 .....25
C-1101-4-1/8OD .....22	C-1102-2-1/2 .....21	F-201-3/4 .....25
C-1101-4-1/4OD .....22	C-1102-3 .....21	F-202 .....25
C-1101-4-3/8OD .....22	C-1102-3-1/2 .....21	F-203 .....25
C-1101-4-1/2OD .....22	C-1102-4 .....21	F-204 .....25
C-1101-4-5/8OD .....22	C-1102-5 .....21	F-205 .....25
C-1101-4-3/4OD .....22	C-1102-6 .....21	F-206-1 .....25
C-1101-4-7/8OD .....22	C-1102-8 .....21	F-206-2 .....25
C-1101-5OD .....22	C-1102-10 .....21	F-207 .....25
C-1101-5-1/8OD .....22	C-1104-3/8 .....21	F-210 .....25
C-1101-5-1/4OD .....22	C-1104-1/2 .....21	F-211 .....25
C-1101-5-3/8OD .....22	C-1104-3/4 .....21	F-212 .....25
C-1101-5-1/2OD .....22	C-1104-1 .....21	F-213 .....25
C-1101-5-5/8OD .....22	C-1104-1-1/4 .....21	F-214 .....25
C-1101-5-3/4OD .....22	C-1104-1-1/2 .....21	F-216 .....25
C-1101-5-7/8OD .....22	C-1104-2 .....21	F-217 .....26
C-1101-6OD .....22	C-1107-3/8 .....23	F-218 .....26
C-1101-6-1/8OD .....22	C-1107-1/2 .....23	F-219 .....26
C-1101-6-1/4OD .....22	C-1107-3/4 .....23	F-220 .....26
C-1101-6-3/8OD .....22	C-1107-1 .....23	
C-1101-6-1/2OD .....22	C-1107-1-1/4 .....23	<b>FITTINGS- ANGLE BRACKETS</b>
C-1101-6-5/8OD .....22	C-1107-1-1/2 .....23	A-301 .....27
C-1101-6-3/4OD .....22	C-1107-2 .....23	A-302 .....27
C-1101-6-7/8OD .....22	C-1107-2-1/2 .....23	A-303 .....27
C-1101-7OD .....22	C-1107-3 .....23	A-304 .....27
C-1101-7-1/8OD .....22	C-1107-3-1/2 .....23	A-305 .....27
C-1101-7-1/4OD .....22	C-1107-4 .....23	A-306 .....27
C-1101-7-3/8OD .....22	C-1108-1/2 .....23	A-309 .....27
C-1101-7-1/2OD .....22	C-1108-3/4 .....23	A-310 .....27
C-1101-7-5/8OD .....22	C-1108-1 .....23	A-311 .....29
C-1101-7-3/4OD .....22	C-1108-1-1/4 .....23	A-312 .....29
C-1101-7-7/8OD .....22	C-1108-1-1/2 .....23	A-313 .....29
C-1101-8OD .....22	C-1108-2 .....23	A-314 .....29
C-1101-1/4CT .....22	C-1108-2-1/2 .....23	A-315 .....29
C-1101-3/8CT .....22	C-1108-3 .....23	A-315-1 .....29
C-1101-1/2CT .....22	C-1108-3-1/2 .....23	A-316 .....28
C-1101-5/8CT .....22	C-1108-4 .....23	A-317 .....28
C-1101-3/4CT .....22	C-1108-5 .....23	A-318-L .....29
C-1101-1CT .....22	C-1108-6 .....23	A-318-R .....29
C-1101-1-1/4CT .....22	C-1109-1/4 .....23	A-319-1 .....28
C-1101-1-1/2CT .....22	C-1109-5/16 .....23	A-319-2 .....28
C-1101-2CT .....22	C-1109-3/8 .....23	A-319-3 .....28
C-1101-2-1/2CT .....22	C-1109-1/2 .....23	A-319-4 .....28
C-1101-3CT .....22	C-1109-5/8 .....23	A-319-5 .....28
C-1101-3-1/2CT .....22		A-319-6 .....28
C-1101-4CT .....22		

# INDEX

A-320-1.....	Page 28
A-320-2.....	28
A-320-3.....	28
A-320-4.....	28
A-322.....	30
A-323.....	30
A-323-22.....	30
A-323-42.....	30
A-323-62.....	30
A-324.....	30
A-325.....	30
A-330-L.....	29
A-330-R.....	29
A-335.....	29
A-336.....	28
A-336-1.....	28
A-337.....	28
A-338-1.....	28
A-338-2.....	28
A-338-3.....	28
A-340-1.....	30
A-340-2.....	30
A-340-3.....	30
A-340-4.....	30
A-340-5.....	30
A-341.....	30

**WING FITTINGS**

A-321-Lq.....	31
A-321-R.....	31
A-321-1-L.....	31
A-321-1-R.....	31
A-326.....	31
A-326-1.....	31
A-327.....	31
A-327-1.....	31
A-328.....	31
A-328-1.....	31
A-3174.....	28
A-3194.....	28

**GENERAL FITTINGS**

B-601-1.....	32
B-601-2.....	32
B-601-3.....	32
B-601-4.....	32
B-601-5.....	32
B-601-6.....	32
B-601-7.....	32
B-602-1.....	32
B-602-2.....	32
B-602-3.....	32
B-603-1.....	32

B-603-2.....	Page 33
B-604.....	33
B-605.....	33
B-606.....	33
B-607.....	33
B-608.....	30
B-609.....	33
B-610.....	32
B-611.....	32
B-612.....	32
B-613.....	32
B-614.....	32
B-615.....	33
B-616.....	33
B-619.....	34
B-619-SQ.....	34
B-619-FL.....	34
B-619-A-SQ.....	34
B-619-A-FL.....	34
B-619-A.....	34
B-620.....	35
B-620-A.....	35
B-620-SQ.....	35
B-620-FL.....	35
B-620-A-SQ.....	35
B-620-A-FL.....	35
B-620-FL-1.....	35

**BEAM CLAMPS**

C-401.....	36
C-402-132.....	36
C-402-122.....	36
C-403.....	36
C-404.....	36
C-405-1.....	36
C-405-2.....	36
C-406.....	36
C-407.....	36
C-408.....	36
C-410.....	37
C-411.....	37
C-412.....	37

**MISC. FITTINGS**

M-601.....	38
M-602.....	38
M-610.....	38
M-611.....	38
M-605.....	38

**ELECTRICAL ACCESSORIES**

C-900.....	41
E-501.....	41

E-502.....	Page 41
E-503.....	41
E-503-SN.....	41
E-504.....	42
E-505.....	42
E-505H.....	42
E-510-1.....	42
E-510-2.....	42
E-510-3.....	42
E-510-4.....	42
E-510-5.....	42
E-511.....	42
E-512.....	42
E-513.....	41

**CONCRETE INSERTS**

M-142-IN.....	44
M-152-IN.....	44
M-164-IN.....	44
1000-EC-1.....	45
1000-EC-2.....	45
1000-EC-3.....	55
1000-EC-5.....	45
1001-EC-1.....	45
1001-EC-2.....	45
1001-EC-3.....	45
M-1200.....	45
N-1200-1/4.....	45
N-1200-3/8.....	45
N-1200-1/2.....	45
N-1200-5/8.....	45
N-1200-3/4.....	45
N-1200-7/8.....	45

**TRAPEZES & BRACKETS**

T-122.....	47
T-132.....	47
T-134.....	47
T-142.....	47
T-152.....	47
T-162.....	47
T-164.....	47
T-165.....	47
T-122-A.....	47
T-132-A.....	47
T-134-A.....	47
T-142-A.....	47
T-152-A.....	47
T-162-A.....	47
T-164-A.....	47
T-165-A.....	47
T-610.....	47



# INDEX

T-611 .....	Page 47
T-612 .....	48
T-613 .....	48
T-615 .....	48
T-616 .....	48
T-620 .....	49
T-621 .....	49
T-622 .....	49

## MINI - STRUT

M-179 .....	51
M-179-A .....	51
M-189 .....	51
M-189-A .....	51
N-841 .....	52
N-842 .....	52
N-843 .....	52
N-844 .....	52
N-851 .....	52
N-852 .....	52
N-853 .....	52
N-854 .....	52
N-861 .....	52
N-862 .....	52
N-863 .....	52
N-864 .....	52

## STAINLESS CHANNEL

M-132SS .....	54
M-132SS-A .....	54
M-132SS-OS .....	54
M-132SS-NS .....	54
M-164SS .....	55
M-164SS-A .....	55
M-164SS-OS .....	55
M-164SS-NS .....	55

## STAINLESS PIPE CLAMPS

C-1101SS-1/4OD .....	56
C-1101SS-3/8OD .....	56
C-1101SS-1/2OD .....	56
C-1101SS-5/8OD .....	56
C-1101SS-3/4OD .....	56
C-1101SS-7/8OD .....	56
C-1101SS-1OD .....	56
C-1101SS-1-1/8OD .....	56
C-1101SS-1-1/4OD .....	56
C-1101SS-1-3/8OD .....	56
C-1101SS-1-1/2OD .....	56
C-1101SS-1-5/8OD .....	56
C-1101SS-1-3/4OD .....	56
C-1101SS-1-7/8OD .....	56

C-1101SS-2OD .....	Page 56
C-1101SS-2-1/8OD .....	56
C-1101SS-2-1/4OD .....	56
C-1101SS-2-3/8OD .....	56
C-1101SS-2-1/2OD .....	56
C-1101SS-2-5/8OD .....	56
C-1101SS-2-3/4OD .....	56
C-1101SS-2-7/8OD .....	56
C-1101SS-3OD .....	56
C-1101SS-3-1/8OD .....	56
C-1101SS-3-1/4OD .....	56
C-1101SS-3-3/8OD .....	56
C-1101SS-3-1/2OD .....	56
C-1101SS-3-5/8OD .....	56
C-1101SS-3-3/4OD .....	56
C-1101SS-3-7/8OD .....	56
C-1101SS-4OD .....	56
C-1101SS-4-1/8OD .....	56
C-1101SS-4-1/4OD .....	56
C-1101SS-4-3/8OD .....	56
C-1101SS-4-1/2OD .....	56
C-1101SS-4-5/8OD .....	56
C-1101SS-4-3/4OD .....	56
C-1101SS-4-7/8OD .....	56
C-1101SS-5OD .....	56
C-1101SS-5-1/8OD .....	56
C-1101SS-5-1/4OD .....	56
C-1101SS-5-3/8OD .....	56
C-1101SS-5-1/2OD .....	56
C-1101SS-5-5/8OD .....	56
C-1101SS-5-3/4OD .....	56
C-1101SS-5-7/8OD .....	56
C-1101SS-6 .....	56
C-1102SS-3/8 .....	56
C-1102SS-1/2 .....	56
C-1102SS-3/4 .....	56
C-1102SS-1 .....	56
C-1102SS-1-1/4 .....	56
C-1102SS-1-1/2 .....	56
C-1102SS-2 .....	56
C-1102SS-2-1/2 .....	56
C-1102SS-3 .....	56
C-1102SS-3-1/2 .....	56
C-1102SS-4 .....	56
C-1102SS-5 .....	56
C-1102SS-6 .....	56
C-1102SS-8 .....	56
C-1102SS-10 .....	56

## SEISMIC BRACING

SR-1 .....	Page 59
SR-2 .....	59
SR-3 .....	60
SR-5 .....	60
SR-8 .....	61
SR-9 .....	61
SR-11 .....	62
SR-12 .....	62
SR-13 .....	63
SR-14 .....	63
SR-15 .....	64
SR-16 .....	64
SR-17 .....	65
SR-18 .....	65

## TERMS AND CONDITIONS

**AGREEMENTS:** All agreements are subject to strikes, accidents or other causes beyond our control.

**GUARANTEE:** We guarantee for one year from date of delivery our manufactured products to the extent that we will replace those having manufacturing defects when used for the purpose which we recommended. If goods are defective, the amount of damage is the price of the defective goods only and no allowance will be made for labor or expense of repairing defective goods or damage resulting from the same. We guarantee the products we sell of other manufacturers to the extent of the guarantees of the respective makers.

**CLAIMS:** No claims for shortages allowed unless made in writing within ten days of receipt of goods.

All materials sent out will be carefully examined, counted and packed. Claims for goods damaged or lost in transit should be made on the carrier, as our responsibility ceases on delivery to the carrier.

**RETURNS:** We cannot accept return of goods unless our permission has been first obtained, in which case same will be credited subject to the following:

1. All material must on its arrival at our plants be found in first-class conditions; if not, cost of putting material in saleable condition will be deducted from credit memoranda issued for material returned.
2. A final deduction of 25% will be made from all credit memoranda's issued for material returned.
3. Transportation charges, if not prepaid, will be deducted from credit memoranda.

**SPECIAL ORDERS:** Order covering special or non-standard goods are not subject to cancellation except on such terms as we may specify on application.

**PRICES:** Subject to change without notice.

**DESIGN:** Product data and dimensions are subject to change without notice.

**TAXES:** To the prices and terms quoted, there will be added any Manufacturers or Sales Tax payable on the transaction under any effective statute.

**MINIMUM INVOICE:** \$25.00

**TERMS:** Net Thirty (30) Days

**FREIGHT ALLOWANCE:** All prices for F.O.B. Factory or point of shipment with no freight allowed.