

PHS

Industries, Inc.

[CLICK HERE TO
START](#)

VARIABLE SPRING SUPPORTS

Variable Catalog 2V

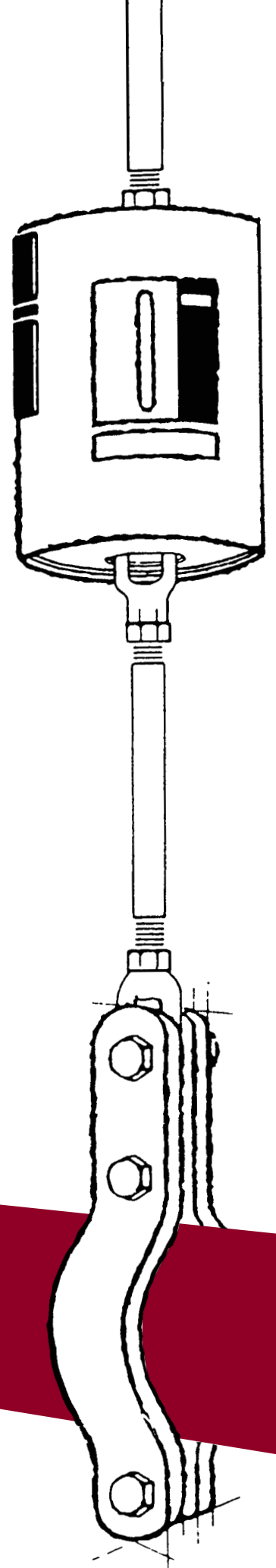

WARRANTY

PHS Industries Inc. ("PHS") warrants to the original buyer (the "Buyer") of products manufactured by it that all such products will be free from defects in material and workmanship for a period of one (1) year after the date of shipment when used in the manner and for the purpose recommended by PHS. PHS does not warrant goods manufactured by other parties, except to the extent that such goods are covered by a warranty to PHS. Notice of a claim for a breach of a warranty must be given to PHS within thirty (30) days after the date that the Buyer first has knowledge of an alleged breach of warranty, but in no event later than one (1) year after the date of shipment. PHS's obligations under this Warranty are limited to its repair or replacement of those products that it determines, to its satisfaction, are defective, and it shall not be liable for any charge or expense incurred by the Buyer in repairing or replacing said products. Notwithstanding anything else contained herein to the contrary, PHS's liability under this Warranty for defective products is limited to the net sales price of such products. The foregoing constitutes the Buyer's sole and exclusive remedy for defective products.

In the event that PHS provides engineering design or fabrication services, the Buyer's acceptance of PHS's design or delivery of the products shall relieve PHS of all further obligations with respect to such design and fabrication, except to the extent that PHS may otherwise expressly provide in a product warranty. In no event, shall PHS be responsible for design errors due to inaccurate or incomplete information provided by the Buyer or its representatives. PHS reserves the right to revise product design without notification.

THIS WARRANTY IS IN LIEU OF ALL OTHER WARRANTIES, EXPRESSED OR IMPLIED, INCLUDING WARRANTIES OF MERCHANTABILITY, FITNESS FOR A PARTICULAR PURPOSE OR ANY OTHER MATTER. IN NO EVENT AND UNDER NO CIRCUMSTANCE SHALL PHS BE LIABLE FOR (A) PERSONAL INJURY OR PROPERTY DAMAGES OR (B) CONSEQUENTIAL, SPECIAL OR INCIDENTAL DAMAGES, WHETHER FOR BREACH OF CONTRACT OR WARRANTY, NEGLIGENCE OR ANY OTHER TORTIOUS ACT OR OMISSION. THIS WARRANTY SHALL NOT APPLY TO PRODUCTS THAT HAVE BEEN SUBJECT TO ALTERATION OR REPAIR MADE BY A PARTY OTHER THAN PHS, ACCIDENT, ABUSE, OR MISUSE. THIS WARRANTY SUPERCEDES ALL CONTRARY OBLIGATIONS IMPOSED ON PHS BY ANY PURCHASE ORDER.

The terms of this Warranty may not be modified or changed except by a writing signed by an authorized officer of PHS.

We take pleasure in presenting to the piping industry the most versatile line of engineered hangers and supports.

We enjoy a position of leadership based upon years of experience in designing and manufacturing quality pipe support devices. Our supports have been employed with outstanding success in the chemical, processing and electric power industries.

Our personnel are committed to respond quickly to customer requirements and service needs on both standard items and specialized applications. We are totally a service oriented company.

We are staffed with engineers knowledgeable in every phase of pipe support design and application. We are equipped to evaluate support design on the basis of function, reliability and manufacturing economy, and to suggest improved designs using either standard or custom items for special requirements.

All products are manufactured under a scientific, statistical quality control system which assures that the finished product will conform to pre-determined standards highest in the industry. It is your guarantee of consistent, uniform quality at all times.

Simply click on the subject to go to the appropriate page

INDEX	PAGE
Service and Specifications	2
Design Features	2
Travel Series, Size and Type Selection.....	2-3
Presets and Travel Stops	3
Installation and Adjustment	3
Size and Series Selection Procedure.....	4
Size and Series Selection Chart (Imperial - IPS)	5
Size and Series Selection Chart (Metric - MKS)	6-7
Nameplate and Cutaway Detail.....	8
Figure 291	8
Manufacturers Conversion Table	9
Series 910 Dimensions	10-16
Series 920 Dimensions	17-23
Series 940 Dimensions	24-30
Series 960 Dimensions	31-37
Series 980 Dimensions	38-44
Technical Information.....	45-48

VARIABLE SPRING SUPPORTS

INTRODUCTION

The Variable Support is a spring loaded device used for the support of piping and equipment where normal vertical movement is anticipated. Variable Supports are manufactured in five different Travel Series which allow up to ten inches of movement and twenty-five different sizes allowing up to 50,000 pounds of load. Seven different mounting Types allow the user the widest selection of configurations to accommodate practically every hanger design.

RECOMMENDED SERVICE

Normally for support of piping systems where thermal changes cause the system dimensions and position to change, and where load transfer to equipment is not a problem. Maximum recommended variation from the operating load is 25%. A constant support should be used when Variability exceeds 25%. Also used for support of equipment and ductwork to customer specifications.

SPECIFICATIONS

All spring units are designed to meet the requirements of:

- ASME Code for Pressure Piping, ASME B31.1, B31.3
- Manufacturers Standardization Society (MSS), SP-58, and SP-69
- Federal Specification A-A-1192-A
- British Standard BS3974

STANDARD DESIGN FEATURES

- Precompression - precompressing the spring coil into the hanger casing saves headroom by reducing the size of the casing, reduces the installed envelope size and also weight and erection time.
- Spring casing protects the coil from damage and weather.
- Steel Construction – spring, casing, and internal parts are fabricated of steel making them rugged and compact. All welding is done to the strict requirements of ASME Section IX.
- The Piston Plate serves as a centering device and guide maintaining coil concentricity under normal operating conditions.
- Load Indicators are visible in the slots and are clearly readable.
- Stainless steel nameplate and travel scale are corrosion resistant.
- All spring hangers are calibrated for accurate loading conditions.
- The unit is preset at the factory to the Cold Load upon request.
- For each series there is a reserve travel at the upper and lower limits of the working range of the spring.
- Allowable spring coil stresses conform to MSS-SP-58.
- Standard finish is a quality rust resisting primer paint.
- A turnbuckle or other suitable coupling is utilized for adjustment of rod type spring units. F type springs utilize an adjustable load column.
- All F type units are supplied with a load flange.

OPTIONAL DESIGN FEATURES

- **Travel Stop** – set at the Cold load position changes the spring into a rigid support for hydrostatic testing or other

purposes. The strength of the Travel Stop is designed so that it can withstand (up to) 2 times the normal load.

- **Adjustable Travel Stop** – allows the resetting of Preset/Travel Stop at any location within the normal operating range of the travel.
- **Limit Stops** – permanently installed to prevent the movement of the pipe beyond a predetermined distance or load within the travel range of the spring.
- **Load Column Guide** – for Type F units only, to prevent tipping of the Load Flange due to anticipated eccentric loading.
- **Extended Load Column** – for Type F units only, the length of the load column is furnished longer than normal per customer request.
- **Lifting Lugs** – are available on larger sizes to facilitate erection and installation.
- **Hot-dip Galvanized Finish** – available for protection against weather and corrosive conditions. The unit is galvanized to ASTM A-153 except the spring coil which is epoxy powder coated to assure protection to the coil as it flexes. The load column of the F Type spring is electro-galvanized. Maximum ambient temperature for the epoxy powdered coating is 350° F (177° C).
- **Epoxy Paint Finish** – available for protection against weather and corrosive conditions. The unit is painted with a two-part zinc rich epoxy paint except the spring coil which is epoxy powder coated.
- **Stainless Steel Construction** – allows the greatest degree of corrosion protection. Constructed completely of stainless steel except the spring coil which can be epoxy powder coated for economy.

DETERMINING THE TRAVEL SERIES

In choosing the proper Variable Spring Travel Series it must first be determined that the calculated movement will fall within the working range of the support and that the variability of the unit does not induce unacceptable loads on the other supports or connections. Five (5) standard Travel Series are available ranging from 1/4" through 10".

SIZE AND SERIES SELECTION PROCEDURE

The size of the Variable Spring support selected depends upon the total piping load to be supported. Complete sizing information is given on the SIZE and SERIES SELECTION PROCEDURE shown in this catalog.

DETERMINING THE TYPE

The type of Variable Spring support to be selected depends upon the physical characteristics of the structure to which the hanger assembly will be attached. Consideration must be given to available headroom, whether the piping will be supported from above or below the hanger, interferences, etc. There are seven (7) standard types available for each Travel Series; they are:

- **Type A** – Is attached to the supporting member by a vertical rod threaded into the top of the case.
- **Type B** – For use where headroom is limited. The unit has a single lug for attachment to the structure to permit connecting with a bolt or pin to a clevis or welded beam attachment.

- **Type C** – Also designed for limited headroom applications. The unit has two lugs welded to the top of the casing to permit connecting with a bolt or pin through a single lug attachment to the structure.
- **Type D** – Designed for use where the variable spring is positioned above the supporting structure and spring adjustment is made from the top.
- **Type E** – Also designed for use where the variable spring is positioned above the supporting structure, but where the spring adjustment must be below the structure on which the case is supported.
- **Type F** – Designed to support piping from below. Used to support pipe from the floor or where support from overhead is not practical.
- **Type G** – For use where headroom is limited or an obstruction prohibits the use of a single rod type Variable Spring.

LOAD PRESET BAR AND TRAVEL STOP

The Load Preset Bars are installed at the factory at the Cold Load setting of the unit.

The Travel Stops, which are optional and will be provided only if ordered, include both the Load Preset Bars to preset the unit at the Cold Load setting and more importantly a down limit stop which locks the unit at that position.

This locking effect results in the unit functioning as a rigid hanger during erection, hydrostatic testing, chemical cleaning or other condition which may cause the unit to exceed its load rating. The Travel Stops are designed for twice the maximum working load of the unit and are installed at the factory with a “Caution” tag which calls attention to the fact that they must be removed before system startup.

INSTALLATION AND ADJUSTMENT

In following these installation instructions note that the adjustment is accomplished by rotating the turnbuckle, rod coupling or load column provided with the spring unit.

Firmly secure the spring unit to the structure. Attach the appropriate rod and/or pipe attachment. Cut the banding holding the Load Presets or Travel Stops. Remove the

down limit stops, if applicable. To remove the Load Presets, the spring load must be increased slightly by use of the adjustment means provided. After the Load Presets or Travel Stops have been removed, readjust the spring unit back to the exact Cold Load setting.

Prior to startup, be sure all of the spring units have had their Load Presets or Travel Stops removed, and have been adjusted to their Cold Load setting.

After startup and when the piping system has stabilized thermally, the Load Indicator on the unit should be at the Hot Load (Operating) setting. If it is not, the spring should be adjusted to the Hot Load setting. No further adjustment should be needed.

ORDERING INSTRUCTIONS:

When ordering a Variable Spring Support please specify for each unit:

1. **Travel Series:** 910, 920, 940, 960, or 980
2. **Spring Type:** A, B, C, D, E, F or G
3. **Spring Size:** 0 through 22 for all Travel Series; 000 and 00 available for Travel Series 920 only
4. **Movement and Direction of movement** from the Cold (Installed) position to the Hot (Operating) position.
5. **Hot Load** (Operating position).
6. **Cold Load** (Installed position).
7. **Rod Spacing:** For Type G only, specify center to center rod dimension
8. **Customer hanger identification** or Mark Number (if any).
9. **Finish:** Primer Painted, Galvanized, Epoxy Painted, Stainless Steel, or Special Customer Requirements.
10. Type B and C units do not come with connection pins to the structure. If required, please order as a Figure 291 and specify pin size and finish.
11. Specify if unit requires Travel Stops, Lifting Lugs, Limit Stop Load Column Guide, Adjustable Travel Stops or any other special feature desired.

TYPICAL APPLICATIONS OF VARIABLE SPRING SUPPORTS

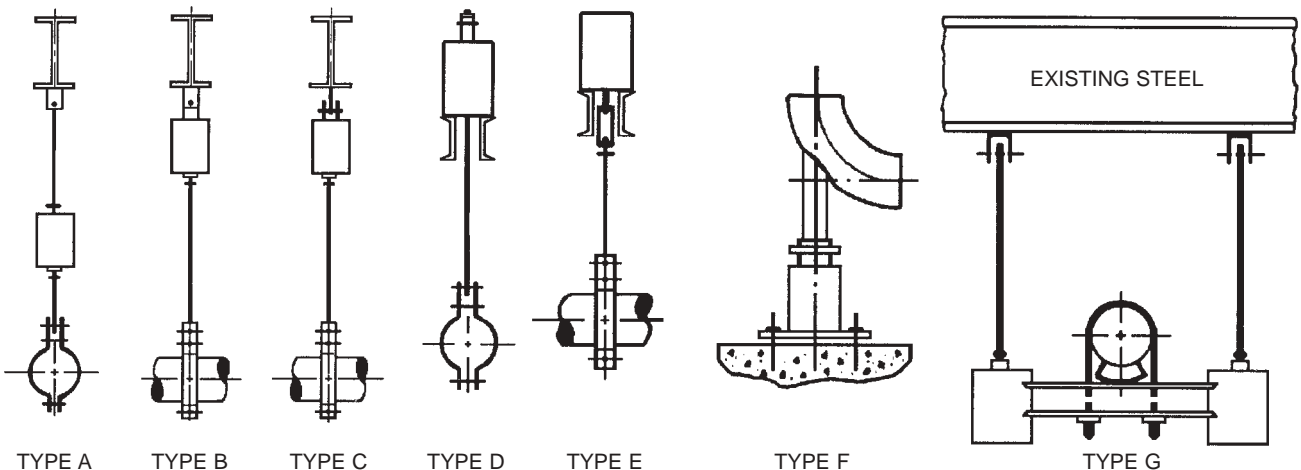

VARIABLE SPRING SUPPORTS

SIZE AND SERIES SELECTION PROCEDURE

The key criteria in selecting the size and series of a Variable Spring support is a factor known as **Variability**. This is a calculation of the percentage change in the supporting force of a variable spring between the Hot (Operating Condition) and the Cold (Installed Condition). The formula is shown below. For practical purposes this percentage relates to the amount of load the spring transfers back into the piping system prior to operation. The lower the Variability the lower the effect on the system while in the Cold position. Since the Hot Load is the actual Operating Load of the piping, loading due to Variability is not a factor.

The **Spring Rate** is the amount of load required to deflect a spring coil over a given distance and is expressed in pounds per inch (Newtons per millimeter).

The **Movement** is the amount the piping system changes due to thermal growth when moving from the Cold to Hot position.

$$\text{Variability} = \frac{\text{Movement} \times \text{Spring Rate}}{\text{Hot Load}}$$

$$\% \text{ Variability} = \text{Variability} \times 100$$

The Cold Load is calculated by adding (for UP movement) or subtracting (for DOWN movement) the product of Spring Rate times the Movement to or from the Hot Load.

If an allowable Variability is not specified, good practice would be to use 25% as specified by MSS-SP-58.

TO SELECT THE PROPER SIZE AND SERIES

1. Find the Hot Load in one of Spring Size columns on the appropriate **SIZE AND SERIES SELECTION CHART** found on page 5, 6, or 7.
2. Calculate the maximum allowable Spring Rate from the formula:

$$\text{Spring Rate} = \frac{\text{Variability} \times \text{Hot Load}}{\text{Movement}}$$

3. Stay in the column and choose the Travel Series with a Spring Rate equal to or less than the value calculated.
4. Calculate the Cold Load and check that both the Hot Load and Cold Load fall within the Working Range of the Travel Series selected.
5. If your requirements are not met, move to an adjacent Spring Size column and recalculate again using the above procedure.

If the Movement or loading requirements cannot be satisfied, select a Travel Series with a greater Working Range and recalculate.

If any combination of Load, Movement and/or Variability cannot achieve the desired results the use of a Constant Support should be considered.

EXAMPLE:

Select a Variable Spring for the following conditions:

Hot Load = 307 lbs. or 1366 N or 139 Kg
Movement = ½" up or 13 mm or 13 mm
Variability = 20% Maximum 20% max. 20% max.

SOLUTION:

1. Calculate Spring Rate.

$$\frac{0.20 \times 307 \text{ lbs.}}{0.50 \text{ inches}} = 122.8 \text{ lbs. per inch, or}$$

$$\frac{0.20 \times 1366 \text{ N}}{13 \text{ mm}} = 21 \text{ N/mm, or}$$

$$\frac{0.20 \times 139 \text{ Kg}}{13 \text{ mm}} = 2.14 \text{ Kg/mm}$$

2. Find the Spring Size column on the **SIZE AND SERIES SELECTION CHART** where the Hot Load is 307 lbs., or 1366 N or 139 Kg.

(A Size 5, Series 920 fits the criteria).

3. Calculate the Cold Load.

$$63 \text{ lbs. per inch} \times 0.50 \text{ inches} = 32 \text{ lbs., or}$$

$$11 \text{ N per mm} \times 13 \text{ mm} = 143 \text{ N, or}$$

$$1.12 \text{ Kg per mm} \times 13 \text{ mm} = 15 \text{ Kg}$$

Since the Movement is UP, add the above load change to the Hot Load.

$$307 \text{ lbs.} + 32 \text{ lbs.} = 339 \text{ lbs. Cold Load, or}$$

$$1366 \text{ N} + 143 \text{ N} = 1509 \text{ N Cold Load, or}$$

$$139 \text{ Kg} + 15 \text{ Kg} = 154 \text{ Kg Cold Load}$$

4. Now check to see if the Hot Load and Cold Load fit in the Working Range of a Size 5 Series 920. If so, you have selected the proper unit.

If you are unable to find the proper size and series of your application, please call us.

SIZE AND SELECTION CHART

Working Range Inches					LOAD TABLE IN POUNDS																						Spring Deflection Inches																									
					SPRING SIZE																																															
980	960	940	920	910	000*	00*	0	1	2	3	4	5	6	7	8	9	10	11	12	13	14	15	16	17	18	19	20	21	22	910	920	940	960	980																		
					7	19	45	63	81	105	141	189	252	336	450	600	780	1020	1350	1800	2400	3240	4500	6000	7980	10620	14100	18750	25005	0	0	0	0	0																		
					7	20	47	66	84	109	147	197	263	350	469	625	813	1063	1406	1875	2500	3375	4688	6250	8313	11063	14688	19531	26047																							
					8	22	49	68	88	114	153	205	273	364	488	650	845	1105	1463	1950	2600	3510	4875	6500	8645	11506	15275	20313	27089																							
					9	24	51	71	91	118	159	213	284	378	506	675	878	1148	1519	2025	2700	3645	5063	6750	8978	11948	15863	21094	28131																							
0	0	0	0	0	10	26	53	74	95	123	165	221	294	392	525	700	910	1190	1575	2100	2800	3780	5250	7000	9310	12390	16450	21875	29173	¼	½	1	1½	2																		
					11	28	54	76	98	127	170	228	305	406	544	725	943	1223	1631	2175	2900	3915	5438	7250	9643	12833	17038	22656	30214																							
					12	30	56	79	101	131	176	236	315	420	563	750	975	1275	1688	2250	3000	4050	5625	7500	9975	13275	17625	23438	31256																							
					12	31	58	81	105	136	182	244	326	434	581	775	1008	1318	1744	2325	3100	4185	5813	7750	10308	13718	18213	24219	32298																							
2	1½	1	½	¼	14	34	60	84	108	140	188	252	336	448	600	800	1040	1360	1800	2400	3200	4320	6000	8000	10640	14160	18800	25000	33340	½	1	2	3	4																		
					14	35	62	87	111	144	194	260	347	462	619	825	1073	1403	1856	2475	3300	4455	6188	8250	10973	14603	19388	25781	34382																							
					15	38	64	89	115	149	200	268	357	476	638	850	1105	1445	1913	2550	3400	4590	6375	8500	11305	15045	19975	26563	35424																							
					16	40	66	92	118	153	206	276	368	490	656	875	1138	1488	1969	2625	3500	4725	6563	8750	11638	15488	20563	27344	36466																							
4	3	2	1	½	17	41	68	95	122	158	212	284	378	504	675	900	1170	1530	2025	2700	3600	4860	6750	9000	11970	15930	21150	28125	37508	¾	1½	3	4½	6																		
					18	43	69	97	125	162	217	291	389	518	694	925	1203	1573	2081	2775	3700	4995	6938	9250	12303	16373	21738	28906	38549																							
					19	45	71	100	128	166	233	299	399	532	713	950	1235	1615	2138	2850	3800	5130	7125	9500	12635	16815	22325	29688	39591																							
					20	47	73	102	132	171	229	307	410	546	731	975	1268	1658	2194	2925	3900	5265	7313	9750	12968	17258	22913	30469	40633																							
6	4½	3	1½	¾	21	49	75	105	135	175	235	315	420	560	750	1000	1300	1700	2250	3000	4000	5400	7500	10000	13300	17700	23500	31250	41675	1	2	4	6	8																		
					21	50	77	108	138	179	241	323	431	574	769	1025	1333	1743	2306	3075	4100	5335	7688	10250	13633	18143	24088	32031	42717																							
					22	53	79	110	142	184	247	331	441	588	788	1050	1365	1785	2363	3150	4200	5670	7875	10500	13965	18585	24675	32813	43759																							
					23	55	81	113	145	188	253	339	452	602	806	1075	1398	1828	2419	3225	4300	5805	8063	10750	14298	19028	25263	33594	44801																							
8	6	4	2	1	24	56	83	116	149	193	259	347	462	616	825	1100	1430	1870	2475	3300	4400	5940	8250	11000	14630	19470	25850	34375	45843	1¼	2½	5	7½	10																		
					25	58	84	118	152	197	264	354	473	630	844	1125	1463	1913	2531	3375	4500	6075	8438	11250	14963	19913	26438	35156	46884																							
					26	60	86	121	155	201	270	362	483	644	863	1150	1496	1955	2588	3450	4600	6210	8625	11500	15295	20355	27025	35938	47926																							
					27	62	88	123	159	206	276	370	494	658	881	1175	1528	1998	2644	3525	4700	6345	8813	11750	15628	20798	27613	36719	48968																							
10	7½	5	2½	1¼	28	64	90	126	162	210	282	378	504	672	900	1200	1560	2040	2700	3600	4800	6480	9000	12000	15960	21240	28200	37500	50010	1½	3	6	9	12																		
					28	66	92	129	165	214	288	386	515	686	919	1225	1593	2083	2756	3675	4900	6615	9188	12250	16293	21863	28788	38281	51052																							
					29	68	94	131	169	219	294	394	525	700	938	1250	1625	2125	2813	3750	5000	6750	9375	12500	16625	22125	29375	39063	52094																							
					30	70	96	134	172	223	300	402	536	714	956	1275	1658	2168	2869	3825	5100	6885	9563	12750	16958	22568	29963	39844	53136																							
					31	72	98	137	176	228	306	410	546	728	975	1300	1690	2210	2925	3900	5200	7020	9750	13000	17290	23010	30550	40625	54178	1¾	3½	7	10½	14																		
					000	00	0	1	2	3	4	5	6	7	8	9	10	11	12	13	14	15	16	17	18	19	20	21	22																							
					SPRING SIZE																																															
					SPRING RATE - Pounds/Inch																																															
				910			30	42	54	70	94	126	168	224	300	400	520	680	900	1200	1600	2160	3000	4000	5320	7080	9400	12500	16670	910																						
				920	7	15	15	21	27	35	47	63	84	112	150	200	260	340	450	600	800	1080	1500	2000	2660	3540	4700	6250	8335		920																					
				940			7	10	13	17	23	31	42	56	75	100	130	170	225	300	400	540	750	1000	1330	1770	2350	3125	4168			940																				
				960			5	7	9	12	16	21	28	37	50	67	87	113	150	200	267	360	500	667	887	1180	1567	2083	2778				960																			
980							4	5	7	9	12	16	21	28	38	50	65	85	113	150	200	270	375	500	665	885	1175	1563	2084					980																		

VARIABLE SPRING SUPPORTS

SIZE AND SELECTION CHART

Working Range Millimeters					LOAD TABLE IN KILOGRAMS																						Spring Deflection Millimeters																									
					SPRING SIZE																																															
980	960	940	920	910	000*	00*	0	1	2	3	4	5	6	7	8	9	10	11	12	13	14	15	16	17	18	19	20	21	22	910	920	940	960	980																		
					3	9	20	29	37	48	64	86	114	152	204	272	354	463	612	816	1088	1469	2041	2721	3619	4816	6395	8503	11340	0	0	0	0	0																		
					3	9	21	30	38	50	67	89	119	159	213	283	368	482	638	850	1134	1531	2126	2834	3766	5017	6661	8858	11813																							
					4	10	22	31	40	52	69	93	124	165	221	295	383	501	663	884	1179	1592	2211	2948	3914	5218	6927	9212	12285																							
					4	11	23	32	41	54	72	96	129	171	230	306	398	520	689	918	1224	1653	2296	3061	4061	5418	7194	9566	12758																							
0	0	0	0	0	5	12	24	33	43	56	74	100	133	178	238	317	413	540	714	952	1270	1714	2381	3175	4209	5619	7460	9921	13230	6	13	25	38	50																		
					5	13	25	35	44	57	77	104	138	184	247	329	427	559	740	986	1315	1776	2466	3288	4356	5820	7727	10275	13703																							
					5	14	26	36	46	59	80	107	143	190	255	340	442	578	765	1020	1360	1837	2551	3401	4503	6020	7993	10629	14175																							
					5	14	26	37	47	61	82	111	148	197	264	351	457	597	791	1054	1406	1898	2636	3515	4651	6221	8260	10984	14648																							
50	38	25	13	6	6	15	27	38	49	63	85	114	152	203	272	363	472	617	816	1088	1451	1959	2721	3628	4798	6422	8526	11338	15120	13	25	51	76	102																		
					6	16	28	39	51	65	88	118	157	209	281	374	486	636	842	1122	1496	2020	2806	3741	4945	6622	8792	11692	15593																							
					7	17	29	40	52	67	90	121	162	216	289	385	501	655	867	1156	1542	2082	2891	3855	5093	6823	9059	12046	16065																							
					7	18	30	42	54	69	93	125	167	222	298	397	516	675	893	1190	1587	2143	2976	3968	5240	7024	9325	12401	16538																							
102	76	51	25	13	8	19	31	43	55	71	95	129	171	229	306	408	530	694	918	1224	1633	2204	3061	4081	5388	7224	9592	12755	17010	19	38	76	114	152																		
					8	20	31	44	57	73	98	132	176	235	315	419	545	713	944	1259	1678	2265	3146	4195	5535	7425	9858	13109	17483																							
					9	20	32	45	58	75	101	136	181	241	323	431	560	732	969	1293	1723	2327	3231	4308	5682	7626	10125	13464	17955																							
					9	21	33	46	60	77	103	139	186	248	332	442	575	752	995	1327	1769	2388	3316	4422	5830	7827	10391	13818	18428																							
152	114	76	38	19	10	22	34	48	61	79	106	143	190	254	340	453	589	771	1020	1361	1814	2449	3401	4535	5977	8027	10657	14172	18900	25	51	102	152	203																		
					10	23	35	49	63	81	108	146	195	260	349	465	604	790	1046	1395	1859	2510	3486	4648	6125	8228	10924	14527	19373																							
					10	24	36	50	64	83	111	150	200	267	357	476	619	809	1071	1429	1905	2571	3571	4762	6272	8429	11190	14881	19845																							
					10	25	37	51	66	85	114	154	205	273	366	487	634	829	1097	1463	1950	2633	3656	4875	6419	8629	11457	15235	20318																							
203	152	102	51	25	11	25	37	52	67	87	116	157	210	279	374	499	648	848	1122	1497	1995	2694	3741	4988	6567	8830	11723	15589	20790	32	64	127.0	191	254																		
					11	26	38	54	69	89	119	161	214	286	383	510	663	867	1148	1531	2041	2755	3827	5102	6714	9031	11990	15944	21263																							
					12	27	39	55	70	91	122	164	219	292	391	521	678	886	1173	1565	2086	2816	3912	5215	6861	9231	12256	16298	21735																							
					12	28	40	56	72	93	124	168	224	298	400	533	692	906	1199	1599	2131	2878	3997	5329	7009	9432	12522	16652	22208																							
254	191	127	64	32	13	29	41	57	73	95	127	171	229	305	408	544	707	925	1224	1633	2177	2939	4082	5442	7156	9633	12789	17007	22680	38	76	152	229	305																		
					13	30	42	58	75	97	129	175	233	311	417	555	722	944	1250	1667	2222	3000	4167	5555	7304	9833	13055	17361	23153																							
					13	31	43	60	77	99	132	179	238	317	425	567	737	964	1276	1701	2267	3061	4252	5669	7451	10034	13322	17715	23625																							
					14	32	43	61	78	101	135	182	243	324	434	578	751	983	1301	1735	2313	3122	4337	5782	7598	10235	13588	18070	24098																							
					14	33	44	62	80	103	137	186	248	330	442	589	766	1002	1327	1769	2358	3184	4422	5895	7746	10435	13855	18424	24570																							
					000	00	0	1	2	3	4	5	6	7	8	9	10	11	12	13	14	15	16	17	18	19	20	21	22																							
					SPRING SIZE																																															
					SPRING RATE - Kg/mm																																															
				910			0.54	0.75	0.96	1.41	1.68	2.25	3.00	4.00	5.36	7.14	9.28	12.14	16.07	21.43	28.57	38.57	53.56	71.42	94.99	126.41	167.84	223.19	297.64	910																						
				920		0.13	0.27	0.27	0.37	0.48	0.62	0.84	1.12	1.50	2.00	2.68	3.57	4.64	6.07	8.03	10.71	14.28	19.28	26.78	35.71	47.49	63.21	83.92	111.59	148.82		920																				
				940			0.13	0.19	0.24	0.31	0.42	0.56	0.75	1.00	1.34	1.79	2.32	3.04	4.02	5.36	7.14	9.64	13.39	17.85	23.75	31.60	41.96	55.80	74.41			940																				
				960			0.09	0.12	0.16	0.21	0.27	0.37	0.50	0.67	0.89	1.19	1.55	2.02	2.68	3.57	4.76	6.43	8.93	11.90	15.84	21.07	27.97	37.20	49.61				960																			
980							0.07	0.09	0.13	0.16	0.21	0.29	0.38	0.50	0.68	0.89	1.16	1.52	2.02	2.68	3.57	4.82	6.70	8.93	11.88	15.80	20.98	27.90	37.22					980																		

VARIABLE SPRING SUPPORTS

VARIABLE SPRING SUPPORTS

TYPICAL NAMEPLATE DESIGNS

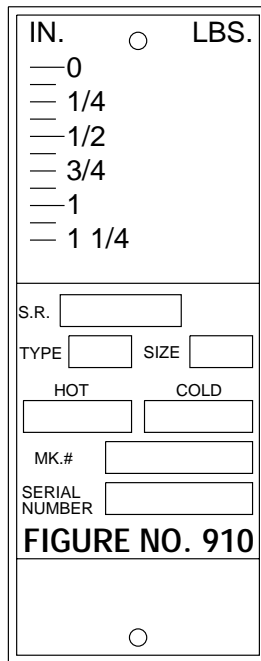
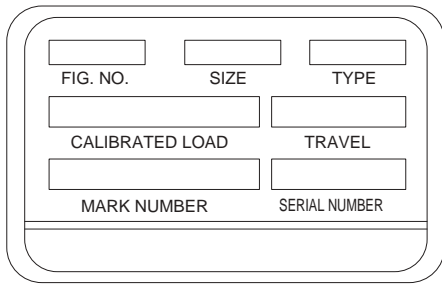

VARIABLE SPRING CUTAWAY DETAIL

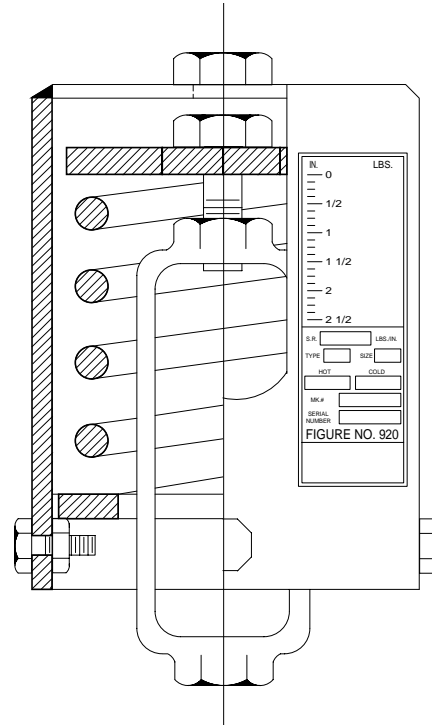

CLEVIS PIN WITH COTTERS

Figure 291

The Figure 291 is used with Type C Variable Springs to secure the spring to the structural connection.

Material: Carbon Steel

Finish: Plain, Hot-dip galvanized

Ordering: Specify pin diameter, figure number, and finish.
For Metric applications Specify Figure M291.

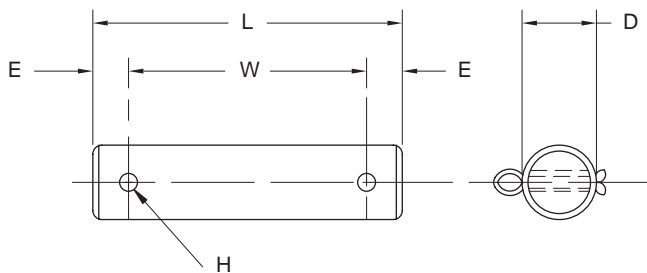

TYPE C PIN SELECTION TABLE

SPRING SIZE	PIN DIA. D	E	H	L	W	MAX. RECOM. LOAD
000 TO 5	5/8	3/8	3/16	3	2 1/4	1130
000 TO 5	16	10	5	76	57	5027
6 TO 8	3/4	3/8	3/16	3	2 1/4	1810
6 TO 8	19	10	5	76	57	8052
9 TO 11	7/8	3/8	1/4	4	3 1/4	2710
9 TO 11	22	10	6	102	83	12055
12 AND 13	1 1/8	3/8	1/4	5	4 1/4	4960
12 AND 13	29	10	6	127	108	22064
14 AND 15	1 3/8	1/2	5/16	5 1/2	4 1/2	8000
14 AND 15	35	13	8	140	114	35587
16	1 5/8	1/2	5/16	6	5	11630
16	41	13	8	152	127	51735
17	1 7/8	5/8	7/16	7	5 3/4	15700
17	48	16	11	178	146	69840
18	2 1/4	5/8	7/16	7 1/4	6	20700
18	57	16	11	184	152	92082
19	2 1/2	5/8	7/16	8	6 3/4	27200
19	64	16	11	203	171	120996
20	2 3/4	5/8	7/16	8	6 3/4	33500
20	70	16	11	203	171	149021
21	3	3/4	7/16	8 1/4	6 3/4	41580
21	76	19	11	210	171	184964
22	3 1/4	3/4	7/16	8 1/2	7	50580
22	83	19	11	216	178	225000

COMPARATIVE SCALED DIFFERENCES

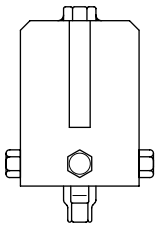

Figure 910

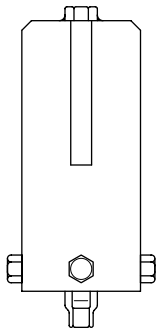

Figure 920

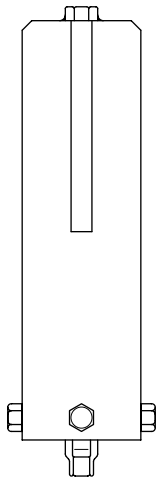

Figure 940

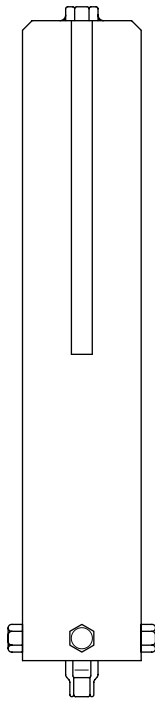

Figure 960

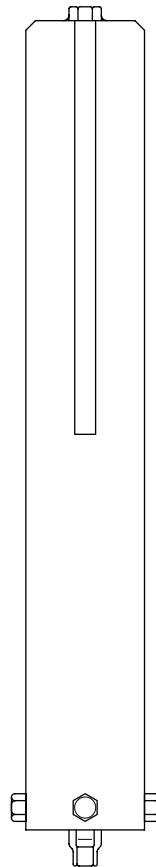
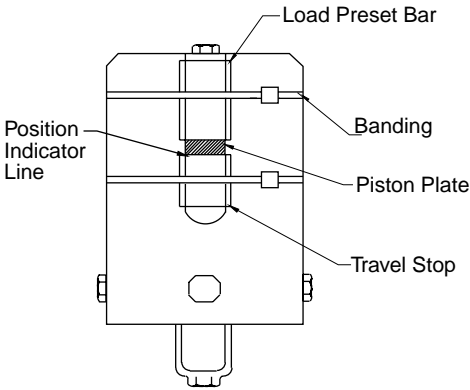

Figure 980

LOAD PRESET BAR AND TRAVEL STOP



MANUFACTURERS CONVERSION TABLE

ANVIL INTERNATIONAL	BASIC ENGINEERS	BERGEN-PATERSON	BERGEN-POWER	BINDER	CARPENTER & PATERSON	CARPENTER & PATERSON LTD.
82	401	VS1 or 3100	910	BV35	482	DV35
B-268	402	VS2 or 3200	920	BV70	468	DV70
98	403	VS4 or 3400	940	BV140	498	DV140
Triple	400	VS6 or 3600	960			DV210
Quad		VS8	980			

COMET/PSL	CENTRAL	FEE & MASON	FRONEK	GRINNELL	LEIBFRIED	NPS
V1	FSC-1	410	15	82	S	VS
V2	FSC-2	420	30	B-268	R	VM
V3	FSC-4	430	60	98	D	VL
	FSC-6		90	Triple		
				Quad		

POWER PIPING	PHS INDUSTRIES	PIPING TECHNOLOGIES	PSC	SHAW-FRONEK
500	910	PTP-1	910	12
600	920	PTP-2	920	25
700	940	PTP-4	960	50
800	960	PTP-6	980	75

VARIABLE SPRING SUPPORTS

SERIES 910 - TYPE A

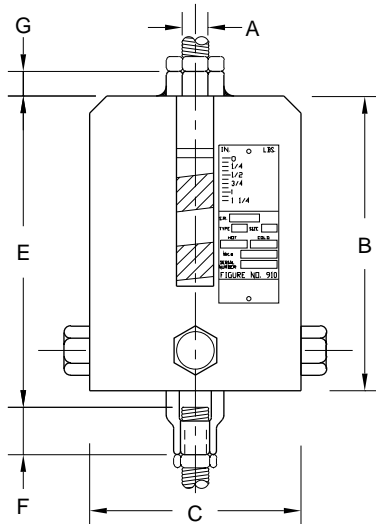

SIZE	ROD SIZE A	CASE LGTH B	CASE DIA. C	ROD T'OUT E	MIN. THD. ENGM'T F	ROD ENGM'T G	APPROX. WGT EACH
0	1/2	6 1/8	4	7 7/8	7/8	7/8	7
0	M12	156	102	194	22	22	3.2
1	1/2	6 3/8	4	8	7/8	7/8	8
1	M12	162	102	203	22	22	3.6
2	1/2	7	4	7 7/8	7/8	7/8	9
2	M12	178	102	194	22	22	4.1
3	1/2	7 3/8	5 9/16	8 3/8	7/8	7/8	12
3	M12	187	141	213	22	22	5.4
4	1/2	7 3/8	5 9/16	7 7/8	7/8	7/8	13
4	M12	187	141	200	22	22	5.9
5	1/2	7 3/8	5 9/16	7 7/8	7/8	7/8	14
5	M12	187	141	194	22	22	6.4
6	5/8	8 1/2	6 3/8	9	1 1/8	1	20
6	M16	216	168	229	29	25	9.1
7	5/8	8 1/2	6 3/8	8 3/8	1 1/8	1	20
7	M16	216	168	213	29	25	9.1
8	5/8	8 1/2	6 3/8	8 1/8	1 1/8	1	22
8	M16	216	168	206	29	25	10
9	3/4	10	8 3/8	10 1/4	1 1/4	1 3/8	40
9	M20	254	219	260	32	35	18.1
10	3/4	10	8 3/8	10 1/4	1 1/4	1 3/8	43
10	M20	254	219	260	32	35	19.5
11	3/4	10	8 3/8	11	1 1/4	1 3/8	50
11	M20	254	219	279	32	35	22.7
12	1	11 1/4	8 3/8	10 7/8	1 5/8	1 5/8	57
12	M24	286	219	276	41	41	25.9
13	1	11 1/4	8 3/8	10 1/2	1 5/8	1 5/8	64
13	M24	286	219	267	41	41	29
14	1 1/4	12	8 3/8	11 3/8	1 3/4	2	68
14	M30	305	219	289	44	51	30.8
15	1 1/4	12	8 3/8	11 3/8	1 3/4	2	88
15	M30	305	219	289	44	51	39.9
16	1 1/2	13 1/2	8 3/8	12 7/8	2	2 1/8	106
16	M36	343	219	327	51	54	48.1
17	1 3/4	15 1/8	8 3/8	14 1/4	2 5/8	2 3/8	143
17	M42	384	219	362	67	60	64.9
18	2	16 5/8	12 3/4	16	2 7/8	2 5/8	251
18	M48	422	324	406	73	67	113.9
19	2 1/4	18 1/4	12 3/4	17 3/8	3 1/2	2 5/8	284
19	M56	464	324	441	89	67	128.8
20	2 1/2	21 5/8	12 3/4	20 3/8	3 7/8	3 1/8	387
20	M64	549	324	518	98	79	175.5
21	2 3/4	23	12 3/4	21 3/4	4 1/4	4 1/8	430
21	M72	584	324	552	108	105	195
22	3	27 1/2	12 3/4	26 3/4	4 1/4	4 1/8	577
22	M80x6	699	324	679	108	105	261.7

Ordering: Specify Figure Number (Travel Series), Type, Size, Hot Load, Cold Load, Movement and Direction of Movement (from the Cold/Installed position to the Hot/Operating position), and Hanger Identification Number (if any). Specify any other optional feature(s) as necessary.

For corrosion resistant units specify the Figure Number with the letter prefix "C", e.g. C910

For metric units specify the Figure Number with the letter prefix "M" e.g. M910 or MC910.

DIMENSIONS		TEMPERATURE	LOADS	WEIGHT
INCHES	FAHRENHEIT		POUNDS	POUNDS
MILLIMETERS	CELSIUS		NEWTONS	KILOGRAMS

FIGURE 910 TYPE B

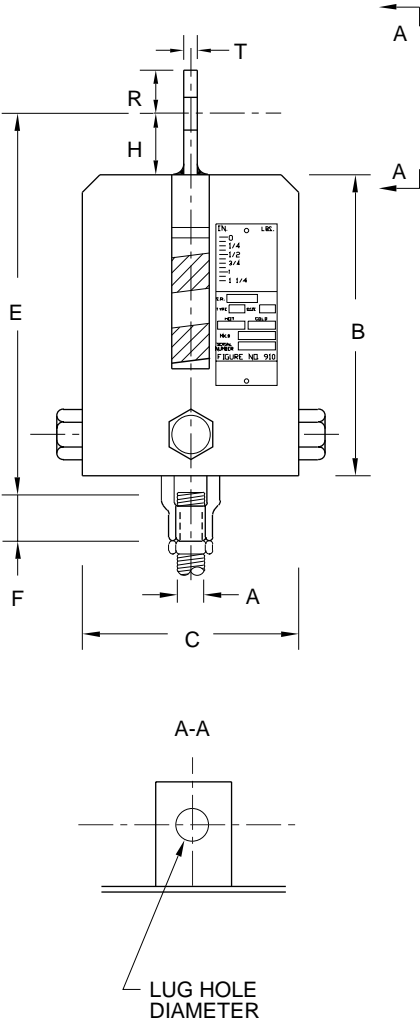

SIZE	ROD SIZE A	CASE LGTH. B	CASE DIA. C	ROD T'OUT E	MIN. THD. ENGM'T F	HGT. OF PIN H	R	T	LUG HOLE DIA.	APPROX. WGT. EACH
0	1/2	6 1/8	4	9 1/8	7/8	1 1/2	1/4	1/4	1 1/16	7
0	M12	156	102	232	22	38	32	6	17	3.2
1	1/2	6 3/8	4	9 1/2	7/8	1 1/2	1/4	1/4	1 1/16	8
1	M12	162	102	241	22	38	32	6	17	3.6
2	1/2	7	4	9 5/8	7/8	1 1/2	1/4	1/4	1 1/16	9
2	M12	178	102	232	22	38	32	6	17	4.1
3	1/2	7 3/8	5 9/16	9 7/8	7/8	1 1/2	1/4	1/4	1 1/16	12
3	M12	187	141	251	22	38	32	6	17	5.4
4	1/2	7 3/8	5 9/16	9 3/8	7/8	1 1/2	1/4	1/4	1 1/16	13
4	M12	187	141	238	22	38	32	6	17	5.9
5	1/2	7 3/8	5 9/16	9 1/8	7/8	1 1/2	1/4	1/4	1 1/16	14
5	M12	187	141	232	22	38	32	6	17	6.4
6	5/8	8 1/2	6 5/8	10 1/2	1 1/8	1 1/2	1/4	1/4	1 3/16	20
6	M16	216	168	267	29	38	32	6	21	9.1
7	5/8	8 1/2	6 5/8	9 7/8	1 1/8	1 1/2	1/4	1/4	1 3/16	20
7	M16	216	168	251	29	38	32	6	21	9.1
8	5/8	8 1/2	6 5/8	9 3/8	1 1/8	1 1/2	1/4	1/4	1 3/16	22
8	M16	216	168	244	29	38	32	6	21	10
9	3/4	10	8 5/8	11 3/4	1 1/4	1 1/2	1/4	3/8	1 5/16	40
9	M20	254	219	298	32	38	32	10	24	18
10	3/4	10	8 5/8	11 3/4	1 1/4	1 1/2	1/4	3/8	1 5/16	43
10	M20	254	219	298	32	38	32	10	24	20
11	3/4	10	8 5/8	12 1/2	1 1/4	1 1/2	1/4	3/8	1 5/16	50
11	M20	254	219	318	32	38	32	10	24	23
12	1	11 1/4	8 5/8	12 7/8	1 5/8	2	1 1/2	1/2	1 1/4	57
12	M24	286	219	327	41	51	38	13	32	26
13	1	11 1/4	8 5/8	12 1/2	1 5/8	2	1 1/2	1/2	1 1/4	64
13	M24	286	219	318	41	51	38	13	32	29
14	1 1/4	12	8 5/8	14 3/8	1 3/4	3	2	5/8	1 1/2	68
14	M30	305	219	365	44	76	51	16	38	31
15	1 1/4	12	8 5/8	14 3/8	1 3/4	3	2	5/8	1 1/2	88
15	M30	305	219	365	44	76	51	16	38	40
16	1 1/2	13 1/2	8 5/8	15 7/8	2	3	2 1/2	3/4	1 3/4	106
16	M36	343	219	403	51	76	64	19	44	48
17	1 3/4	15 1/8	8 5/8	17 1/4	2 5/8	3	2 1/2	3/4	2	143
17	M42	384	219	438	67	76	64	19	51	65
18	2	16 5/8	12 3/4	20	2 7/8	4	3	3/4	2 3/8	251
18	M48	422	324	508	73	102	76	19	60	114
19	2 1/4	18 1/4	12 3/4	21 7/8	3 1/2	4 1/2	3	3/4	2 5/8	284
19	M56	464	324	556	89	114	76	19	67	129
20	2 1/2	21 5/8	12 3/4	24 7/8	3 7/8	4 1/2	4	1	2 7/8	387
20	M64	549	324	632	98	114	102	25	73	176
21	2 3/4	23	12 3/4	26 1/4	4 1/4	4	4	1	3 1/8	430
21	M72	584	324	667	108	114	102	25	79	195
22	3	27 1/2	12 3/4	31 3/4	4 1/4	5	4	1	3 3/8	577
22	M80x6	699	324	806	108	127	102	25	86	262

Ordering: Specify Figure Number (Travel Series), Type, Size, Hot Load, Cold Load, Movement and Direction of Movement (from the Cold/Installed position to the Hot/Operating position), and Hanger Identification Number (if any). Specify any other optional feature(s) as necessary.

Pins for attachment to the structure are not included with the unit and must be ordered separately as a Figure 291, shown on page 8 of this catalog. For ordering specify Figure Number, pin diameter and finish.

For corrosion resistant units specify the Figure Number with the letter prefix "C", e.g. C910

For metric units specify the Figure Number with the letter prefix "M" e.g. M910 or MC910.

DIMENSIONS		TEMPERATURE	LOADS		WEIGHT
INCHES	FARENHEIT		POUNDS	POUNDS	
MILLIMETERS	CELSIUS		NEWTONS	KILOGRAMS	

VARIABLE SPRING SUPPORTS

SERIES 910 - TYPE C

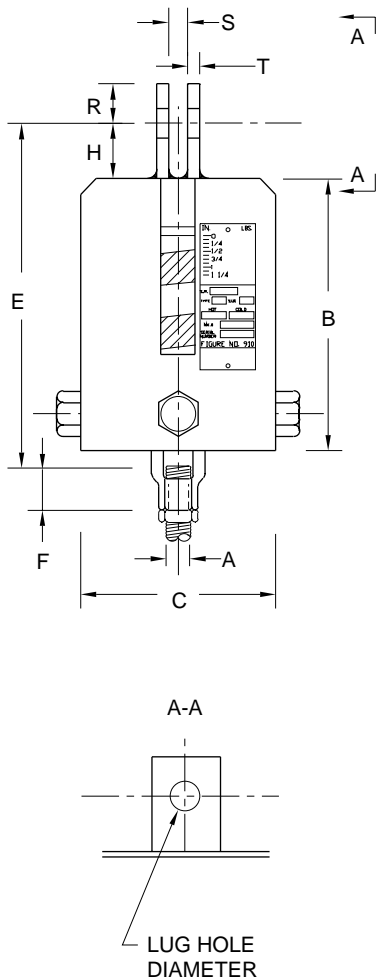

SIZE	ROD SIZE A	CASE LGTH. B	CASE DIA. C	ROD T'OUT E	MIN. THD. ENGM'T F	HGT. OF PIN H	R	S	T	LUG HOLE DIA.	APPROX. WGT EACH
0	1/2	6 3/8	4	9 1/8	7/8	1 1/2	1 1/4	7/8	1/4	1 1/16	7
0	M12	156	102	232	22	38	32	22	6	17	3.2
1	1/2	6 3/8	4	9 1/2	7/8	1 1/2	1 1/4	7/8	1/4	1 1/16	8
1	M12	162	102	241	22	38	32	22	6	17	3.6
2	1/2	6 3/4	4	9 5/8	7/8	1 1/2	1 1/4	7/8	1/4	1 1/16	9
2	M12	171	102	232	22	38	32	22	6	17	4.1
3	1/2	7 3/8	5 1/16	9 7/8	7/8	1 1/2	1 1/4	7/8	1/4	1 1/16	12
3	M12	187	141	251	22	38	32	22	6	17	5.4
4	1/2	7 3/8	5 1/16	9 3/8	7/8	1 1/2	1 1/4	7/8	1/4	1 1/16	13
4	M12	187	141	238	22	38	32	22	6	17	5.9
5	1/2	7 3/8	5 1/16	9 1/8	7/8	1 1/2	1 1/4	7/8	1/4	1 1/16	14
5	M12	187	141	232	22	38	32	22	6	17	6.4
6	5/8	8 1/2	6 3/8	10 1/2	1 1/8	1 1/2	1 1/4	1 1/16	1/4	1 3/16	20
6	M16	216	168	267	29	38	32	27	6	21	9.1
7	5/8	8 1/2	6 3/8	9 7/8	1 1/8	1 1/2	1 1/4	1 1/16	1/4	1 3/16	20
7	M16	216	168	251	29	38	32	27	6	21	9.1
8	5/8	8 1/2	6 3/8	9 3/8	1 1/8	1 1/2	1 1/4	1 1/16	1/4	1 3/16	22
8	M16	216	168	244	29	38	32	27	6	21	10
9	3/4	10	8 3/8	11 3/4	1 1/4	1 1/2	1 1/4	1 1/4	3/8	1 5/16	40
9	M20	254	219	298	32	38	32	32	10	24	18
10	3/4	10	8 3/8	11 3/4	1 1/4	1 1/2	1 1/4	1 1/4	3/8	1 5/16	43
10	M20	254	219	298	32	38	32	32	10	24	20
11	3/4	10	8 3/8	12 1/2	1 1/4	1 1/2	1 1/4	1 1/4	3/8	1 5/16	50
11	M20	254	219	318	32	38	32	32	10	24	23
12	1	11 1/4	8 3/8	12 7/8	1 5/8	2	1 1/2	1 1/4	1/2	1 1/4	57
12	M24	286	219	327	41	51	38	32	13	32	26
13	1	11 1/4	8 3/8	12 1/2	1 5/8	2	1 1/2	1 1/4	1/2	1 1/4	64
13	M24	286	219	318	41	51	38	32	13	32	29
14	1 1/4	12	8 3/8	14 3/8	1 3/4	3	2	2	1/2	1 1/2	68
14	M30	305	219	365	44	76	51	51	13	38	31
15	1 1/4	12	8 3/8	14 3/8	1 3/4	3	2	2	5/8	1 1/2	88
15	M30	305	219	365	44	76	51	51	16	38	40
16	1 1/2	13 1/2	8 3/8	15 7/8	2	3	2 1/2	2 3/8	3/4	1 3/4	106
16	M36	343	219	403	51	76	64	60	19	44	48
17	1 3/4	15 1/8	8 3/8	17 1/4	2 3/8	3	2 1/2	2 3/8	3/4	2	143
17	M42	384	219	438	67	76	64	60	19	51	65
18	2	16 3/8	12 3/4	20	2 7/8	4	3	2 7/8	3/4	2 3/8	251
18	M48	422	324	508	73	102	76	73	19	60	114
19	2 1/4	18 1/4	12 3/4	21 7/8	3 1/2	4 1/2	3	3 1/8	3/4	2 5/8	284
19	M56	464	324	556	89	114	76	79	19	67	129
20	2 1/2	21 3/8	12 3/4	24 7/8	3 7/8	4 1/2	4	3 3/8	1	2 7/8	387
20	M64	549	324	632	98	114	102	86	25	73	176
21	2 3/4	23	12 3/4	26 1/4	4 1/4	4 1/2	4	3 3/8	1	3 3/8	430
21	M72	584	324	667	108	114	102	92	25	79	195
22	3	27 1/2	12 3/4	31 3/4	4 1/4	5	4	3 3/8	1	3 3/8	577
22	M80x6	699	324	806	108	127	102	98	25	86	262

Ordering: Specify Figure Number (Travel Series), Type, Size, Hot Load, Cold Load, Movement and Direction of Movement (from the Cold/Installed position to the Hot/Operating position), and Hanger Identification Number (if any). Specify any other optional feature(s) as necessary.

Pins for attachment to the structure are not included with the unit and must be ordered separately as a Figure 291, shown on page 8 of this catalog. For ordering specify Figure Number, pin diameter and finish.

For corrosion resistant units specify the Figure Number with the letter prefix "C", e.g. C910

For metric units specify the Figure Number with the letter prefix "M" e.g. M910 or MC910.

DIMENSIONS		TEMPERATURE	LOADS	WEIGHT
INCHES	FAHRENHEIT		POUNDS	POUNDS
MILLIMETERS	CELSIUS		NEWTONS	KILOGRAMS

SERIES 910 TYPE D

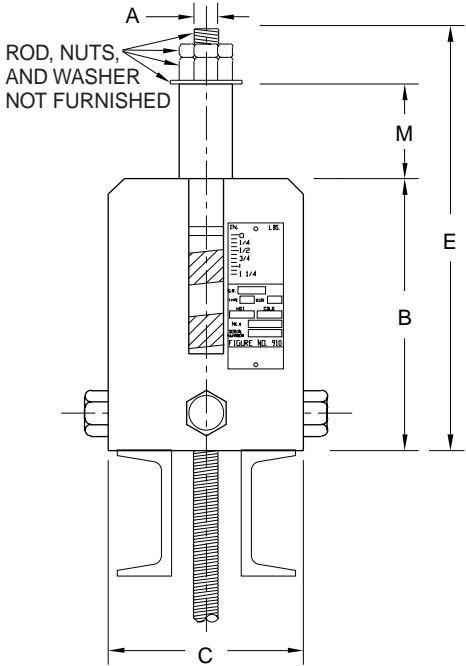

HANGER SIZE	ROD SIZE A	CASE LENGTH B	CASE DIA. C	ROD TAKEOUT E	HGT. OF SPACER M	APPROX. WEIGHT EACH
0	1/2	6 1/8	4	9 1/2	2 1/4	6
0	M12	156	102	241	57	2.7
1	1/2	6 3/8	4	9 3/8	2 1/4	6
1	M12	162	102	238	57	2.7
2	1/2	7	4	10	2 1/4	7
2	M12	178	102	254	57	3.2
3	1/2	7 3/8	5 9/16	10 3/8	2 1/4	10
3	M12	187	141	264	57	4.5
4	1/2	7 3/8	5 9/16	10 3/8	2 1/4	11
4	M12	187	141	264	57	5
5	1/2	7 3/8	5 9/16	10 3/8	2 1/4	12
5	M12	187	141	264	57	5.4
6	5/8	8 1/2	6 5/8	11 3/4	2 3/8	18
6	M16	216	168	298	60	8.2
7	5/8	8 1/2	6 5/8	11 3/4	2 3/8	17
7	M16	216	168	298	60	7.7
8	5/8	8 1/2	6 5/8	11 3/4	2 3/8	20
8	M16	216	168	298	60	9.1
9	3/4	10	8 5/8	13 3/4	2 5/8	36
9	M20	254	219	349	67	16
10	3/4	10	8 5/8	13 3/4	2 5/8	39
10	M20	254	219	349	67	18
11	3/4	10	8 5/8	13 3/4	2 5/8	46
11	M20	254	219	349	67	21
12	1	11 1/4	8 5/8	15 5/8	2 7/8	50
12	M24	286	219	397	73	23
13	1	11 1/4	8 5/8	15 5/8	2 7/8	57
13	M24	286	219	397	73	26
14	1 1/4	12	8 5/8	17 1/8	3 1/4	59
14	M30	305	219	435	83	27
15	1 1/4	12	8 5/8	17	3 1/8	77
15	M30	305	219	432	79	35
16	1 1/2	13 1/2	8 5/8	19 1/4	3 1/2	95
16	M36	343	219	489	89	43
17	1 3/4	15 1/8	8 5/8	21 1/2	3 3/4	128
17	M42	384	219	546	95	58
18	2	16 5/8	12 3/4	23 5/8	4	230
18	M48	422	324	600	102	104
19	2 1/4	18 1/4	12 3/4	25 7/8	4 1/4	258
19	M56	464	324	657	108	117
20	2 1/2	21 5/8	12 3/4	29 5/8	4 1/4	342
20	M64	549	324	752	108	155
21	2 3/4	23	12 3/4	31 5/8	4 1/2	379
21	M72	584	324	752	114	172
22	3	27 1/2	12 3/4	37	5	485
22	M80x6	699	324	940	127	220

Ordering: Specify Figure Number (Travel Series), Type, Size, Hot Load, Cold Load, Movement and Direction of Movement (from the Cold/Installed position to the Hot/Operating position), and Hanger Identification Number (if any). Specify any other optional feature(s) as necessary.

For corrosion resistant units specify the Figure Number with the letter prefix “C”, e.g. C910

For metric units specify the Figure Number with the letter prefix “M” e.g. M910 or MC910.

DIMENSIONS		TEMPERATURE	LOADS		WEIGHT
INCHES	FAHRENHEIT		POUNDS	POUNDS	
MILLIMETERS	CELSIUS		NEWTONS	KILOGRAMS	

VARIABLE SPRING SUPPORTS

SERIES 910 TYPE E

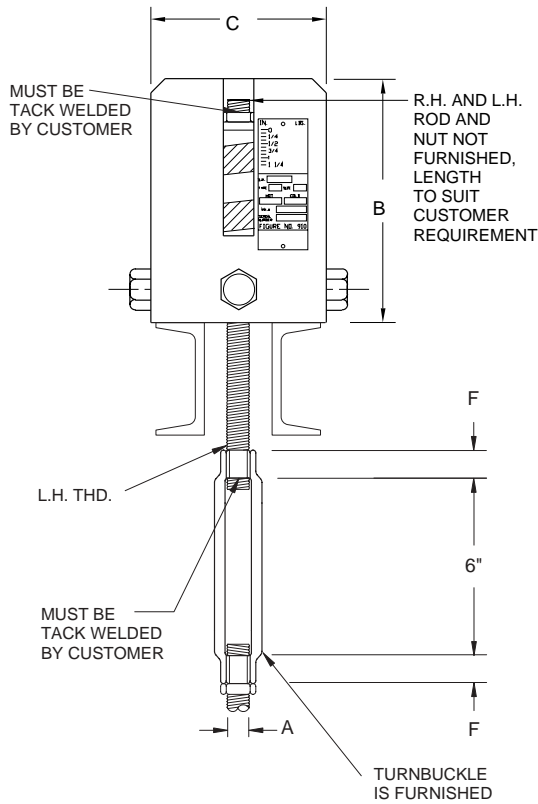

HANGER SIZE	ROD SIZE A	CASE LENGTH B	CASE DIAMETER C	MIN. THD. ENGMT F	APPROX. WEIGHT EACH
0	1/2	6 1/8	4	7/8	6
0	M12	156	102	22	2.7
1	1/2	6 3/8	4	7/8	6
1	M12	162	102	22	2.7
2	1/2	7	4	7/8	7
2	M12	178	102	22	3.2
3	1/2	7 3/8	5 9/16	7/8	10
3	M12	187	141	22	4.5
4	1/2	7 3/8	5 9/16	7/8	11
4	M12	187	141	22	5
5	1/2	7 3/8	5 9/16	7/8	12
5	M12	187	141	22	5.4
6	5/8	8 1/2	6 3/8	1 1/8	17
6	M16	216	168	29	7.7
7	5/8	8 1/2	6 3/8	1 1/8	18
7	M16	216	168	29	8.2
8	5/8	8 1/2	6 3/8	1 1/8	20
8	M16	216	168	29	9.1
9	3/4	10	8 5/8	1 1/4	36
9	M20	254	219	32	16
10	3/4	10	8 5/8	1 1/4	39
10	M20	254	219	32	18
11	3/4	10	8 5/8	1 1/4	46
11	M20	254	219	32	21
12	1	11 1/4	8 5/8	1 5/8	50
12	M24	286	219	41	23
13	1	11 1/4	8 5/8	1 5/8	57
13	M24	286	219	41	26
14	1 1/4	12	8 5/8	1 3/4	59
14	M30	305	219	44	27
15	1 1/4	12	8 5/8	1 3/4	77
15	M30	305	219	44	35
16	1 1/2	13 1/2	8 5/8	2	95
16	M36	343	219	51	43
17	1 3/4	15 1/8	8 5/8	2 5/8	128
17	M42	384	219	67	58
18	2	16 5/8	12 3/4	2 7/8	230
18	M48	422	324	73	104
19	2 1/4	18 1/4	12 3/4	3 1/2	258
19	M56	464	324	89	117
20	2 1/2	21 5/8	12 3/4	3 7/8	342
20	M64	549	324	98	155
21	2 3/4	23	12 3/4	4 1/4	379
21	M72	584	324	108	172
22	3	27 1/2	12 3/4	4 1/4	485
22	M80X6	699	324	108	220

Ordering: Specify Figure Number (Travel Series), Type, Size, Hot Load, Cold Load, Movement and Direction of Movement (from the Cold/Installed position to the Hot/Operating position), and Hanger Identification Number (if any). Specify any other optional feature(s) as necessary.

For corrosion resistant units specify the Figure Number with the letter prefix "C", e.g. C910

For metric units specify the Figure Number with the letter prefix "M" e.g. M910 or MC910.

DIMENSIONS	TEMPERATURE	LOADS	WEIGHT
INCHES	FAHRENHEIT	POUNDS	POUNDS
MILLIMETERS	CELSIUS	NEWTONS	KILOGRAMS

SERIES 910 - TYPE F

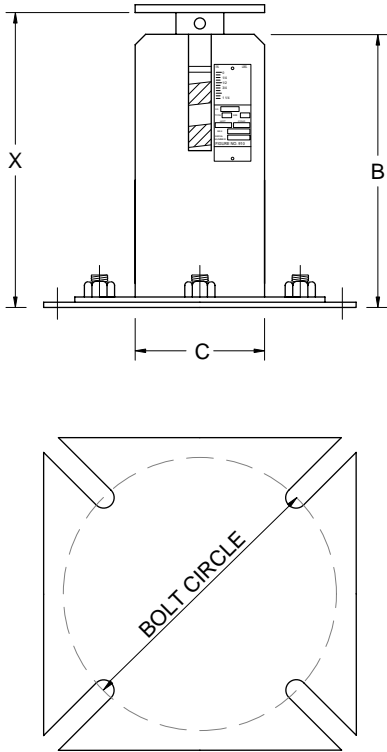

SIZE	CASE LNPTH. B	CASE DIA. C	BOTTOM FLANGE BOLT DIA.	BOTTOM FLANGE	BOLT CIRCLE		OVERALL LNPTH. X **		LOAD FLANGE DIA.	LOAD FLANGE THICK.	APPROX. WGT. EACH
					MIN.	MAX.	MIN.	MAX.			
0	4 7/8	4	5/8	1/4 x 7 1/2 x 7 1/2	7	9 3/4	6 3/8	6 3/8	3 3/8	1/4	12
0	117	102	M16	6 x 190 x 190	178	248	156	168	98	6	5.4
1	4 7/8	4	5/8	1/4 x 7 1/2 x 7 1/2	7	9 3/4	6 3/8	6 3/8	3 3/8	1/4	12
1	124	102	M16	6 x 190 x 190	178	248	162	175	98	6	5.4
2	5 1/2	4	5/8	1/4 x 7 1/2 x 7 1/2	7	9 3/4	7	7 1/2	3 3/8	1/4	13
2	140	102	M16	6 x 190 x 190	178	248	178	191	98	6	5.9
3	5 1/8	5 1/16	3/4	1/4 x 7 1/2 x 7 1/2	7 3/4	9 3/4	6 1/2	7 1/8	5 3/8	1/4	18
3	130	141	M20	6 x 190 x 190	197	248	165	181	137	6	8.2
4	5 1/2	5 1/16	3/4	1/4 x 7 1/2 x 7 1/2	7 3/4	9 3/4	6 7/8	7 1/2	5 3/8	1/4	20
4	140	141	M20	6 x 190 x 190	197	248	175	191	137	6	9.1
5	5 7/8	5 1/16	3/4	1/4 x 7 1/2 x 7 1/2	7 3/4	9 3/4	7 1/4	7 7/8	5 3/8	1/4	21
5	149	141	M20	6 x 190 x 190	197	248	184	200	137	6	9.5
6	5 7/8	6 5/8	3/4	3/8 x 9 x 9	9 1/4	10 1/2	7 1/2	8	6 3/8	1/4	33
6	149	168	M20	9 x 229 x 229	235	267	191	203	162	6	15
7	5 7/8	6 5/8	3/4	3/8 x 9 x 9	9 1/4	10 1/2	8 1/8	8 3/4	6 3/8	1/4	33
7	149	168	M20	9 x 229 x 229	235	267	206	222	162	6	15
8	6 3/8	6 5/8	3/4	3/8 x 9 x 9	9 1/4	10 1/2	8 3/8	9	6 3/8	1/4	35
8	168	168	M20	9 x 229 x 229	235	267	213	229	162	6	16
9	7 3/8	8 5/8	3/4	1/2 x 13 1/4 x 13 1/4	10 1/16	16 1/4	9 3/8	10 3/8	8 3/8	1/2	68
9	187	219	M20	13 x 337 x 337	268	413	238	264	213	13	31
10	7 7/8	8 5/8	3/4	1/2 x 13 1/4 x 13 1/4	10 1/16	16 1/4	9 7/8	10 7/8	8 3/8	1/2	71
10	200	219	M20	13 x 337 x 337	268	413	251	276	213	13	32
11	6 1/2	8 5/8	3/4	1/2 x 13 1/4 x 13 1/4	10 1/16	16 1/4	8 1/2	9 1/2	8 3/8	1/2	74
11	165	219	M20	13 x 337 x 337	268	413	216	241	213	13	34
12	6 7/8	8 5/8	3/4	1/2 x 13 1/4 x 13 1/4	10 1/16	16 1/4	8 7/8	9 7/8	8 3/8	1/2	78
12	175	219	M20	13 x 337 x 337	268	413	225	251	213	13	35
13	8 1/4	8 5/8	3/4	1/2 x 13 1/4 x 13 1/4	10 1/16	16 1/4	10 1/4	11 1/4	8 3/8	1/2	81
13	210	219	M20	13 x 337 x 337	268	413	260	286	213	13	37
14	8 1/2	8 5/8	3/4	1/2 x 13 1/4 x 13 1/4	10 1/16	16 1/4	10 1/2	11 1/2	8 3/8	1/2	84
14	216	219	M20	13 x 337 x 337	268	413	267	292	213	13	38
15	8 3/4	8 5/8	3/4	1/2 x 13 1/4 x 13 1/4	10 1/16	16 1/4	10 3/4	11 3/4	8 3/8	1/2	98
15	222	219	M20	13 x 337 x 337	268	413	273	298	213	13	44
16	10	8 5/8	3/4	1/2 x 13 1/4 x 13 1/4	10 1/16	16 1/4	12	13	8 3/8	1/2	113
16	254	219	M20	13 x 337 x 337	268	413	305	330	213	13	51
17	11 1/4	8 5/8	3/4	1/2 x 13 1/4 x 13 1/4	10 1/16	16 1/4	13 1/4	14 1/4	8 3/8	1/2	138
17	286	219	M20	13 x 337 x 337	268	413	337	362	213	13	63
18	12 1/8	12 3/4	3/4	5/8 x 17 1/4 x 17 1/4	15 3/4	21	13 3/8	14 7/8	12 1/2	1/2	253
18	308	324	M20	16 x 438 x 438	400	533	352	378	318	13	115
19	13 1/8	12 3/4	3/4	5/8 x 17 1/4 x 17 1/4	15 3/4	21	14 7/8	15 7/8	12 1/2	1/2	271
19	333	324	M20	16 x 438 x 438	400	533	378	403	318	13	123
20	15 1/4	12 3/4	3/4	5/8 x 17 1/4 x 17 1/4	15 3/4	21	17	18	12 1/2	1/2	337
20	387	324	M20	16 x 438 x 438	400	533	432	457	318	13	153
21	15 7/8	12 3/4	3/4	5/8 x 17 1/4 x 17 1/4	15 3/4	21	18	19	12 1/2	1/2	356
21	403	324	M20	16 x 438 x 438	400	533	457	483	318	13	161
22	20 1/8	12 3/4	3/4	5/8 x 17 1/4 x 17 1/4	15 3/4	21	22 1/4	23 1/4	12 1/2	1/2	443
22	511	324	M20	16 x 438 x 438	400	533	565	591	318	13	201

** The Installed Height should be the mid-point between the Maximum and Minimum Overall Height "X", plus the thickness of the Load Flange, and plus any DOWN piping movement when applicable.

Ordering: Specify Figure Number (Travel Series), Type, Size, Hot Load, Cold Load, Movement and Direction of Movement (from the Cold/Installed position to the Hot/Operating position), Dimension X (Installed Height) and Hanger Identification Number (if any). Specify any other optional feature(s) as necessary.

For corrosion resistant units specify the Figure Number with the letter prefix "C", e.g. C910
 For metric units specify the Figure Number with the letter prefix "M" e.g. M910 or MC910.

DIMENSIONS		TEMPERATURE	LOADS	WEIGHT
INCHES		FAHRENHEIT	POUNDS	POUNDS
MILLIMETERS		CELSIUS	NEWTONS	KILOGRAMS

VARIABLE SPRING SUPPORTS

Ordering: Specify Figure Number (Travel Series), Type, Size, Total Load, Hot Load per spring, Cold Load per spring, Movement and Direction of Movement (from the Cold/Installed position to the Hot/Operating position), Center to Center of Rods dimension and Hanger Identification Number (if any). Specify any other optional feature(s) as necessary.

For corrosion resistant units specify the Figure Number with the letter prefix "C", e.g. C910

For metric units specify the Figure Number with the letter prefix "M" e.g. M910 or MC910.

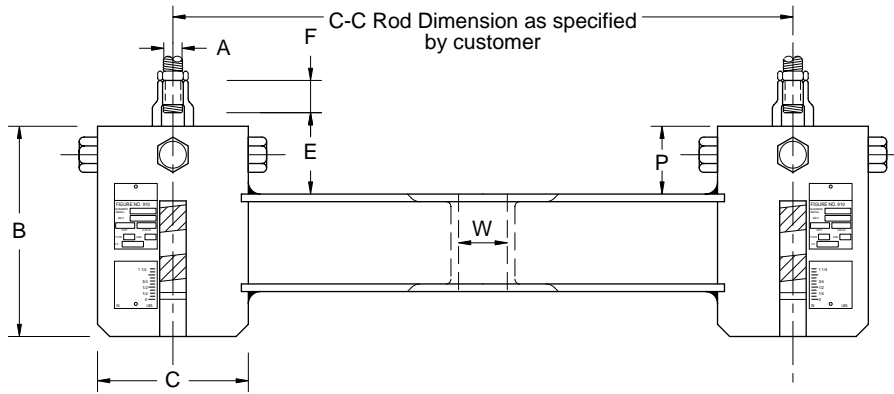
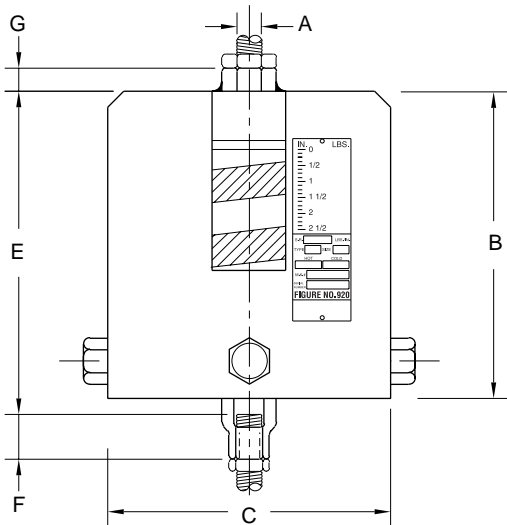

FIGURE 910 TYPE G

HANGER SIZE	ROD SIZE A	CASE LENGTH B	CASE DIAMETER C	ROD TAKEOUT E	MIN. THD. ENGM'T F	CHANNEL SIZE	MAX. C - C	CHANNEL SPACING W	P	APPROX. WEIGHT EACH
0	1/2	6 1/8	4	2 3/8	7/8	C3 x 4.1	24	5/8	1 1/2	25
0	M12	156	102	60	22	C75 x 6	610	16	38	11.3
1	1/2	6 3/8	4	2 3/8	7/8	C3 x 4.1	24	5/8	1 1/2	25
1	M12	162	102	60	22	C75 x 6	610	16	38	11.3
2	1/2	7	4	2 3/8	7/8	C3 x 4.1	24	5/8	1 1/2	26
2	M12	178	102	60	22	C75 x 6	610	16	38	11.8
3	1/2	7 3/8	5 1/16	2 7/8	7/8	C3 x 4.1	30	3/4	2	32
3	M12	187	141	73	22	C75 x 6	762	19	51	14.5
4	1/2	7 3/8	5 1/16	2 7/8	7/8	C3 x 4.1	30	3/4	2	35
4	M12	187	141	73	22	C75 x 6	762	19	51	15.9
5	1/2	7 3/8	5 1/16	2 7/8	7/8	C3 x 4.1	30	3/4	2	37
5	M12	187	141	73	22	C75 x 6	762	19	51	16.8
6	5/8	8 1/2	6 3/8	3 1/8	1 1/8	C3 x 4.1	36	1	2	49
6	M16	216	168	79	29	C75 x 6	914	25	51	22.2
7	5/8	8 1/2	6 3/8	3 1/8	1 1/8	C3 x 4.1	36	1	2	48
7	M16	216	168	79	29	C75 x 6	914	25	51	21.8
8	5/8	8 1/2	6 3/8	3 1/8	1 1/8	C3 x 4.1	36	1	2	53
8	M16	216	168	79	29	C75 x 6	914	25	51	24
9	3/4	10	8 3/8	4 1/4	1 1/4	C4 x 5.4	36	1 1/4	3	86
9	M20	254	219	108	32	C100 x 8	914	32	76	39
10	3/4	10	8 3/8	4 1/4	1 1/4	C4 x 5.4	36	1 1/4	3	92
10	M20	254	219	108	32	C100 x 8	914	32	76	41.7
11	3/4	10	8 3/8	4 1/4	1 1/4	C4 x 5.4	36	1 1/4	3	109
11	M20	254	219	108	32	C100 x 8	914	32	76	49.4
12	1	11 1/4	8 3/8	5 5/8	1 5/8	C5 x 6.7	36	1 1/2	4	121
12	M24	286	219	143	41	C130 x 10	914	38	102	54.9
13	1	11 1/4	8 3/8	5 5/8	1 5/8	C5 x 6.7	36	1 1/2	4	138
13	M24	286	219	143	41	C130 x 10	914	38	102	62.6
14	1 1/4	12	8 3/8	5 3/4	1 3/4	C5 x 6.7	33	1 1/2	4	144
14	M30	305	219	146	44	C130 x 10	838	38	102	65.3
15	1 1/4	12	8 3/8	5 3/4	1 3/4	C8 x 11.5	36	2 1/8	4	190
15	M30	305	219	146	44	C200 x 17	914	54	102	86.2
16	1 1/2	13 1/2	8 3/8	6	2	C8 x 11.5	36	2 1/8	4	226
16	M36	343	219	152	51	C200 x 17	914	54	102	102.5
17	1 3/4	15 1/8	8 3/8	6 5/8	2 5/8	C8 x 11.5	36	2 1/8	4	300
17	M42	384	219	168	67	C200 x 17	914	54	102	136.1
18	2	16 5/8	12 3/4	6 7/8	2 7/8	C12 x 20.7	42	2 5/8	4	518
18	M48	422	324	175	73	C130 x 31	1067	67	102	235
19	2 1/4	18 3/4	12 3/4	7 1/2	3 1/2	C12 x 20.7	42	2 5/8	4	582
19	M56	464	324	191	89	C130 x 31	1067	67	102	264
20	2 1/2	21 5/8	12 3/4	7 7/8	3 3/8	C12 x 20.7	40	2 5/8	4	763
20	M64	549	324	200	98	C130 x 31	1016	67	102	346.1
21	2 3/4	23	12 3/4	8 1/4	4 1/4	C15 x 33.9	48	3 1/8	4	874
21	M72	584	324	210	108	C380 x 50	1219	79	102	396.4
22	3	27 1/2	12 3/4	8 1/4	4 1/4	C15 x 33.9	48	3 3/8	4	1163
22	M80x6	699	324	210	108	C380 x 50	1219	86	102	527.5

DIMENSIONS		TEMPERATURE	LOADS	WEIGHT
INCHES	FAHRENHEIT		POUNDS	POUNDS
MILLIMETERS	CELSIUS		NEWTONS	KILOGRAMS

SERIES 920 - TYPE A



SIZE	ROD SIZE A	CASE LGTH B	CASE DIA. C	ROD T'OUT E	MIN. THD. ENGM'T F	ROD ENGM'T G	APPRX. WGT. EACH
000	1/2	8	4	7 7/8	7/8	7/8	6
000	M12	203	102	200	22	22	2.7
00	1/2	9 1/4	4	8 7/8	7/8	7/8	7
00	M12	235	102	225	22	22	3.2
0	1/2	9 7/8	4	9 1/2	7/8	7/8	10
0	M12	251	102	241	22	22	4.5
1	1/2	9 7/8	4	9 1/2	7/8	7/8	11
1	M12	251	102	241	22	22	5
2	1/2	9 7/8	4	9 1/2	7/8	7/8	12
2	M12	251	102	241	22	22	5.4
3	1/2	10	5 9/16	9 5/8	7/8	7/8	17
3	M12	254	141	244	22	22	7.7
4	1/2	10	5 9/16	9 5/8	7/8	7/8	19
4	M12	254	141	241	22	22	8.6
5	1/2	10	5 9/16	9 5/8	7/8	7/8	20
5	M12	254	141	24	22	22	9.1
6	5/8	11 3/4	6 5/8	11 1/4	1 1/8	1 1/8	28
6	M16	298	168	286	29	29	13
7	5/8	11 3/4	6 5/8	11 1/4	1 1/8	1 1/8	29
7	M16	298	168	286	29	29	13
8	5/8	11 3/4	6 5/8	11 1/4	1 1/8	1 1/8	32
8	M16	298	168	286	29	29	15
9	3/4	12 1/2	8 5/8	12 1/8	1 1/4	1 1/4	54
9	M20	318	219	308	32	32	24
10	3/4	13 3/4	8 5/8	13 3/8	1 1/4	1 1/4	67
10	M20	349	219	340	32	32	30
11	3/4	12 1/2	8 5/8	12 1/8	1 1/4	1 1/4	68
11	M20	318	219	308	32	32	31
12	1	13	8 5/8	12 5/8	1 5/8	1 5/8	76
12	M24	330	219	321	41	41	34
13	1	15 5/8	8 5/8	15 1/4	1 5/8	1 5/8	85
13	M24	397	219	387	41	41	39
14	1 1/4	16 1/2	8 5/8	16	1 3/4	1 3/4	90
14	M30	419	219	406	44	44	41
15	1 1/4	16 1/2	8 5/8	16	1 3/4	1 3/4	120
15	M30	419	219	406	44	44	54
16	1 1/2	19	8 5/8	18 5/8	2	2	156
16	M36	483	219	473	51	51	71
17	1 3/4	21 1/4	8 5/8	20 5/8	2 5/8	2 5/8	211
17	M42	540	219	524	67	67	96
18	2	20 3/4	12 3/4	20 3/8	2 7/8	2 7/8	338
18	M48	527	324	518	73	73	153
19	2 1/4	23 1/2	12 3/4	23 1/8	3 1/2	3 1/2	382
19	M56	597	324	587	89	89	173
20	2 1/2	29 1/4	12 3/4	28 7/8	3 7/8	3 7/8	546
20	M64	743	324	733	98	98	248
21	2 3/4	32 3/8	12 3/4	32	4 1/4	4 1/4	601
21	M72	822	324	813	108	108	273
22	3	38 5/8	12 3/4	38 5/8	4 1/4	4 1/4	811
22	M80x6	981	324	981	108	108	368

Ordering: Specify Figure Number (Travel Series), Type, Size, Hot Load, Cold Load, Movement and Direction of Movement (from the Cold/Installed position to the Hot/Operating position), and Hanger Identification Number (if any). Specify any other optional feature(s) as necessary.

For corrosion resistant units specify the Figure Number with the letter prefix "C", e.g. C920

For metric units specify the Figure Number with the letter prefix "M" e.g. M920 or MC920.

DIMENSIONS		TEMPERATURE	LOADS	WEIGHT
INCHES	FAHRENHEIT	POUNDS	POUNDS	
MILLIMETERS	CELSIUS	NEWTONS	KILOGRAMS	

FIGURE 920 TYPE B

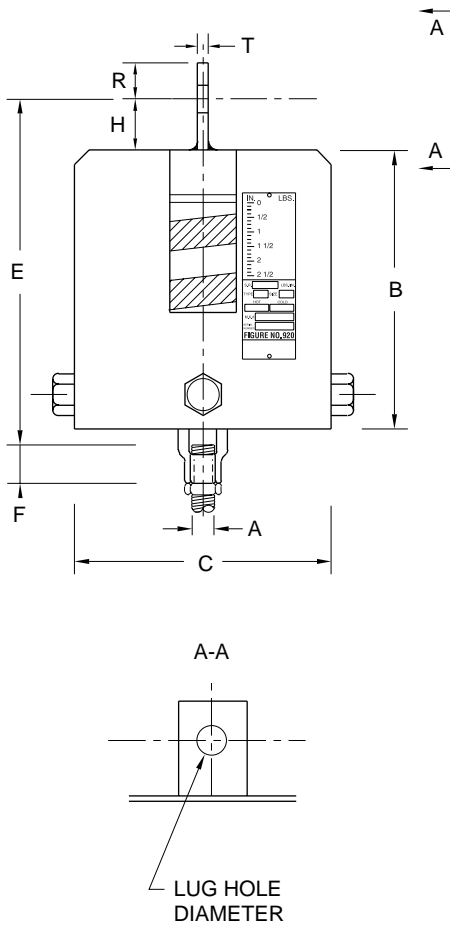

SIZE	ROD SIZE A	CASE LENGH B	CASE DIA. C	ROD T'OUT E	MIN. THREAD ENGMT F	HGT. OF PIN H	R	T	LUG HOLE DIA.	APPROX. WEIGHT EACH
000	1/2	8	4	9 1/8	7/8	1 1/2	1/4	1/4	1 1/16	6
000	M12	203	102	232	22	38	32	6	17	2.7
00	1/2	9 1/4	4	10 1/8	7/8	1 1/2	1/4	1/4	1 1/16	7
00	M12	235	102	257	22	38	32	6	17	3.2
0	1/2	9 7/8	4	11	7/8	1 1/2	1/4	1/4	1 1/16	10
0	M12	251	102	279	22	38	32	6	17	4.5
1	1/2	9 7/8	4	11	7/8	1 1/2	1/4	1/4	1 1/16	11
1	M12	251	102	279	22	38	32	6	17	5
2	1/2	9 7/8	4	11	7/8	1 1/2	1/4	1/4	1 1/16	12
2	M12	251	102	279	22	38	32	6	17	5.4
3	1/2	10	5 9/16	11 1/8	7/8	1 1/2	1/4	1/4	1 1/16	17
3	M12	254	141	283	22	38	32	6	17	7.7
4	1/2	10	5 9/16	11 1/8	7/8	1 1/2	1/4	1/4	1 1/16	19
4	M12	254	141	283	22	38	32	6	17	8.6
5	1/2	10	5 9/16	11 1/8	7/8	1 1/2	1/4	1/4	1 1/16	20
5	M12	254	141	283	22	38	32	6	17	9.1
6	5/8	11 3/4	6 5/8	12 3/4	1 1/8	1 1/2	1/4	1/4	1 3/16	28
6	M16	298	168	324	29	38	32	6	21	13
7	5/8	11 3/4	6 5/8	12 3/4	1 1/8	1 1/2	1/4	1/4	1 3/16	29
7	M16	298	168	324	29	38	32	6	21	13
8	5/8	11 3/4	6 5/8	12 3/4	1 1/8	1 1/2	1/4	1/4	1 3/16	32
8	M16	298	168	324	29	38	32	6	21	15
9	3/4	12 1/2	8 5/8	13 5/8	1 1/4	1 1/2	1/4	3/8	1 5/16	54
9	M20	318	219	346	32	38	32	10	24	24
10	3/4	13 3/4	8 5/8	14 7/8	1 1/4	1 1/2	1/4	3/8	1 5/16	67
10	M20	349	219	378	32	38	32	10	24	30
11	3/4	12 1/2	8 5/8	13 5/8	1 1/4	1 1/2	1/4	3/8	1 5/16	68
11	M20	318	219	346	32	38	32	10	24	31
12	1	13	8 5/8	14 5/8	1 5/8	2	1 1/2	1/2	1 1/4	76
12	M24	330	219	371	41	51	38	13	32	34
13	1	15 5/8	8 5/8	17 1/4	1 5/8	2	1 1/2	1/2	1 1/4	85
13	M24	397	219	438	41	51	38	13	32	39
14	1 1/4	16 1/2	8 5/8	19	1 3/4	3	1 1/2	1/2	1 1/2	90
14	M30	419	219	483	44	76	38	13	38	41
15	1 1/4	16 1/2	8 5/8	19	1 3/4	3	2	5/8	1 1/2	120
15	M30	419	219	483	44	76	51	16	38	54
16	1 1/2	19	8 5/8	21 5/8	2	3	2 1/2	3/4	1 3/4	156
16	M36	483	219	549	51	76	64	19	44	71
17	1 3/4	21 1/4	8 5/8	23 3/8	2 5/8	3	2 1/2	3/4	2	211
17	M42	540	219	600	67	76	64	19	51	96
18	2	20 3/4	12 3/4	24 3/8	2 7/8	4	3	3/4	2 3/8	338
18	M48	527	324	619	73	102	76	19	60	153
19	2 1/4	23 1/2	12 3/4	27 5/8	3 1/2	4 1/2	3	3/4	2 5/8	382
19	M56	597	324	702	89	114	76	19	67	173
20	2 1/2	29 1/4	12 3/4	33 3/8	3 7/8	4 1/2	4	1	2 7/8	546
20	M64	743	324	848	98	114	102	25	73	248
21	2 3/4	32 3/8	12 3/4	36 1/2	4 1/4	4 1/2	4	1	3 1/8	601
21	M72	822	324	927	108	114	102	25	79	273
22	3	38 5/8	12 3/4	43 5/8	4 1/4	5	4	1	3 3/8	811
22	M80x6	981	324	1108	108	127	102	25	86	368

Ordering: Specify Figure Number (Travel Series), Type, Size, Hot Load, Cold Load, Movement and Direction of Movement (from the Cold/Installed position to the Hot/Operating position), and Hanger Identification Number (if any). Specify any other optional feature(s) as necessary.

Pins for attachment to the structure are not included with the unit and must be ordered separately as a Figure 291, shown on page 8 of this catalog. For ordering specify Figure Number, pin diameter and finish.

For corrosion resistant units specify the Figure Number with the letter prefix "C", e.g. C910

For metric units specify the Figure Number with the letter prefix "M" e.g. M910 or MC910.

DIMENSIONS		TEMPERATURE	LOADS	WEIGHT
INCHES	FAHRENHEIT		POUNDS	POUNDS
MILLIMETERS	CELSIUS		NEWTONS	KILOGRAMS

SERIES 920 - TYPE C

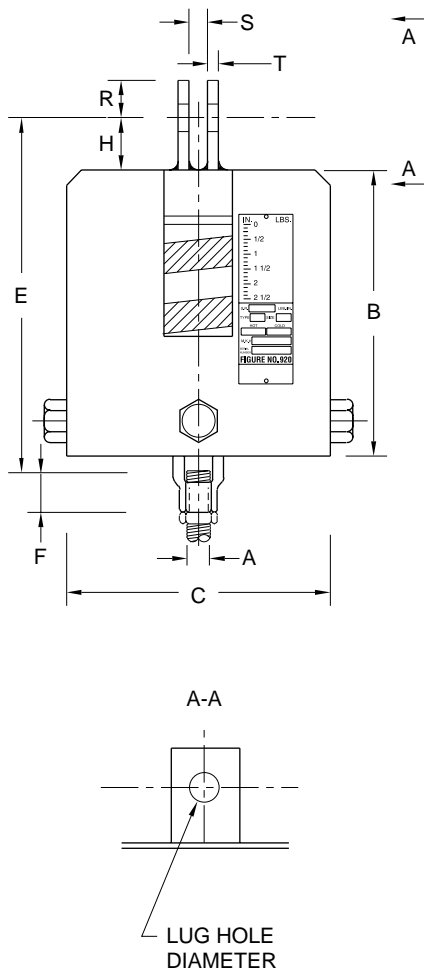

SIZE	ROD SIZE A	CASE LENGH B	CASE DIA. C	ROD T'OUT E	MIN. THD. ENGM'T F	HGT. OF PIN H	R	S	T	LUG HOLE DIA.	APPROX. WEIGHT EACH
000	1/2	8	4	9 1/8	7/8	1 1/2	1 1/4	7/8	1/4	1 1/16	6
000	M12	203	102	232	22	38	32	22	6	17	2.7
00	1/2	9 1/4	4	10 1/8	7/8	1 1/2	1 1/4	7/8	1/4	1 1/16	7
00	M12	235	102	257	22	38	32	22	6	17	3.2
0	1/2	9 7/8	4	11	7/8	1 1/2	1 1/4	7/8	1/4	1 1/16	10
0	M12	251	102	279	22	38	32	22	6	17	4.5
1	1/2	9 7/8	4	11	7/8	1 1/2	1 1/4	7/8	1/4	1 1/16	11
1	M12	251	102	279	22	38	32	22	6	17	5
2	1/2	9 7/8	4	11	7/8	1 1/2	1 1/4	7/8	1/4	1 1/16	12
2	M12	251	102	279	22	38	32	22	6	17	5.4
3	1/2	10	5 1/16	11 1/8	7/8	1 1/2	1 1/4	7/8	1/4	1 1/16	17
3	M12	254	141	283	22	38	32	22	6	17	7.7
4	1/2	10	5 1/16	11 1/8	7/8	1 1/2	1 1/4	7/8	1/4	1 1/16	19
4	M12	254	141	283	22	38	32	22	6	17	8.6
5	1/2	10	5 1/16	11 1/8	7/8	1 1/2	1 1/4	7/8	1/4	1 1/16	20
5	M12	254	141	283	22	38	32	22	6	17	9.1
6	3/8	11 3/4	6 5/8	12 3/4	1 1/8	1 1/2	1 1/4	1 1/16	1/4	1 1/16	28
6	M16	298	168	324	29	38	32	27	6	21	13
7	3/8	11 3/4	6 5/8	12 3/4	1 1/8	1 1/2	1 1/4	1 1/16	1/4	1 1/16	29
7	M16	298	168	324	29	38	32	27	6	21	13
8	3/8	11 3/4	6 5/8	12 3/4	1 1/8	1 1/2	1 1/4	1 1/16	1/4	1 1/16	32
8	M16	298	168	324	29	38	32	27	6	21	15
9	3/4	12 1/2	8 5/8	13 5/8	1 1/4	1 1/2	1 1/4	1 1/4	3/8	1 5/16	54
9	M20	318	219	346	32	38	32	32	10	24	24
10	3/4	13 3/4	8 5/8	14 7/8	1 1/4	1 1/2	1 1/4	1 1/4	3/8	1 5/16	67
10	M20	349	219	378	32	38	32	32	10	24	30
11	3/4	12 1/2	8 5/8	13 5/8	1 1/4	1 1/2	1 1/4	1 1/4	3/8	1 5/16	68
11	M20	318	219	346	32	38	32	32	10	24	31
12	1	13	8 5/8	14 5/8	1 5/8	2	1 1/2	1 1/4	1/2	1 1/4	76
12	M24	330	219	371	41	51	38	32	13	32	34
13	1	15 5/8	8 5/8	17 1/4	1 5/8	2	1 1/2	1 1/4	1/2	1 1/4	85
13	M24	397	219	438	41	51	38	32	13	32	39
14	1 1/4	16 1/2	8 5/8	19	1 3/4	3	1 1/2	2	1/2	1 1/2	90
14	M30	419	219	483	44	76	38	51	13	38	41
15	1 1/4	16 1/2	8 5/8	19	1 3/4	3	2	2	5/8	1 1/2	120
15	M30	419	219	483	44	76	51	51	16	38	54
16	1 1/2	19	8 5/8	21 5/8	2	3	2 1/2	2 3/8	3/4	1 3/4	156
16	M36	483	219	549	51	76	64	60	19	44	71
17	1 3/4	21 1/4	8 5/8	23 5/8	2 5/8	3	2 1/2	2 3/8	3/4	2	211
17	M42	540	219	600	67	76	64	60	19	51	96
18	2	20 3/4	12 3/4	24 3/8	2 7/8	4	3	2 7/8	3/4	2 3/8	338
18	M48	527	324	619	73	102	76	73	19	60	153
19	2 1/4	23 1/2	12 3/4	27 5/8	3 1/2	4 1/2	3	3 1/8	3/4	2 5/8	382
19	M56	597	324	702	89	114	76	79	19	67	173
20	2 1/2	29 1/4	12 3/4	33 3/8	3 7/8	4 1/2	4	3 3/8	1	2 7/8	546
20	M64	743	324	848	98	114	102	86	25	73	248
21	2 3/4	32 3/8	12 3/4	36 1/2	4 1/4	4 1/2	4	3 5/8	1	3 1/8	601
21	M72	822	324	927	108	114	102	92	25	79	273
22	3	38 5/8	12 3/4	43 5/8	4 1/4	5	4	3 7/8	1	3 3/8	811
22	M80x6	981	324	1108	108	127	102	98	25	86	368

Ordering: Specify Figure Number (Travel Series), Type, Size, Hot Load, Cold Load, Movement and Direction of Movement (from the Cold/Installed position to the Hot/Operating position), and Hanger Identification Number (if any). Specify any other optional feature(s) as necessary.

Pins for attachment to the structure are not included with the unit and must be ordered separately as a Figure 291, shown on page 8 of this catalog. For ordering specify Figure Number, pin diameter and finish.

For corrosion resistant units specify the Figure Number with the letter prefix "C", e.g. C910

For metric units specify the Figure Number with the letter prefix "M" e.g. M910 or MC910.

DIMENSIONS		TEMPERATURE	LOADS	WEIGHT
INCHES	FARENHEIT	POUNDS	POUNDS	
MILLIMETERS	CELSIUS	NEWTONS	KILOGRAMS	

VARIABLE SPRING SUPPORTS

SERIES 920 TYPE D

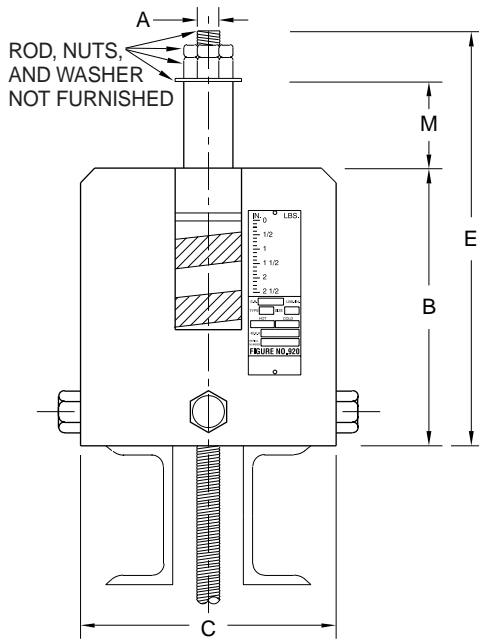

HANGER SIZE	ROD SIZE A	CASE LENGTH B	CASE DIA. C	ROD TAKEOUT E	HGT OF SPACER M	APPROX. WEIGHT EACH
000	1/2	8	4	12 3/4	4	6
000	M12	203	102	324	102	2.7
00	1/2	9 1/4	4	14	4	7
00	M12	235	102	356	102	3.2
0	1/2	9 7/8	4	14 5/8	4	8
0	M12	251	102	371	102	3.6
1	1/2	9 7/8	4	14 5/8	4	9
1	M12	251	102	371	102	4.1
2	1/2	9 7/8	4	14 5/8	4	10
2	M12	251	102	371	102	4.5
3	1/2	10	5 9/16	14 3/4	4	14
3	M12	254	141	375	102	6.4
4	1/2	10	5 9/16	14 3/4	4	16
4	M12	254	141	375	102	7.3
5	1/2	10	5 9/16	14 3/4	4	19
5	M12	254	141	375	102	8.6
6	5/8	11 3/4	6 5/8	16 1/16	4	25
6	M16	298	168	424	102	11
7	5/8	11 3/4	6 5/8	16 1/16	4	25
7	M16	298	168	424	102	11
8	5/8	11 3/4	6 5/8	16 1/16	4	29
8	M16	298	168	424	102	13
9	3/4	12 1/2	8 5/8	18	4 3/8	50
9	M20	318	219	457	111	23
10	3/4	13 3/4	8 5/8	19 1/4	4 3/8	54
10	M20	349	219	489	111	24
11	3/4	12 1/2	8 5/8	18	4 3/8	64
11	M20	318	219	457	111	29
12	1	13	8 5/8	19 1/8	4 5/8	70
12	M24	330	219	486	117	32
13	1	15 5/8	8 5/8	21 3/4	4 5/8	79
13	M24	397	219	552	117	36
14	1 1/4	16 1/2	8 5/8	23 3/8	5	84
14	M30	419	219	594	127	38
15	1 1/4	16 1/2	8 5/8	23 1/4	4 7/8	111
15	M30	419	219	591	124	50
16	1 1/2	19	8 5/8	26 1/2	5 1/4	142
16	M36	483	219	673	133	64
17	1 3/4	21 1/4	8 5/8	29 3/8	5 1/2	190
17	M36	540	219	746	140	86
18	2	20 3/4	12 3/4	29 1/2	5 3/4	311
18	M48	527	324	749	146	141
19	2 1/4	23 1/2	12 3/4	32 7/8	6	348
19	M56	597	324	835	152	158
20	2 1/2	29 1/4	12 3/4	39	6	487
20	M64	743	324	991	152	221
21	2 3/4	32 3/8	12 3/4	42 3/4	6 1/4	534
21	M72	822	324	1086	159	242
22	3	38 5/8	12 3/4	48 1/8	5	714
22	M80x6	981	324	1222	127	324

Ordering: Specify Figure Number (Travel Series), Type, Size, Hot Load, Cold Load, Movement and Direction of Movement (from the Cold/Installed position to the Hot/Operating position), and Hanger Identification Number (if any). Specify any other optional feature(s) as necessary.

For corrosion resistant units specify the Figure Number with the letter prefix "C", e.g. C920

For metric units specify the Figure Number with the letter prefix "M" e.g. M920 or MC920.

DIMENSIONS	TEMPERATURE	LOADS	WEIGHT
INCHES	FAHRENHEIT	POUNDS	POUNDS
MILLIMETERS	CELSIUS	NEWTONS	KILOGRAMS

SERIES 920 TYPE E

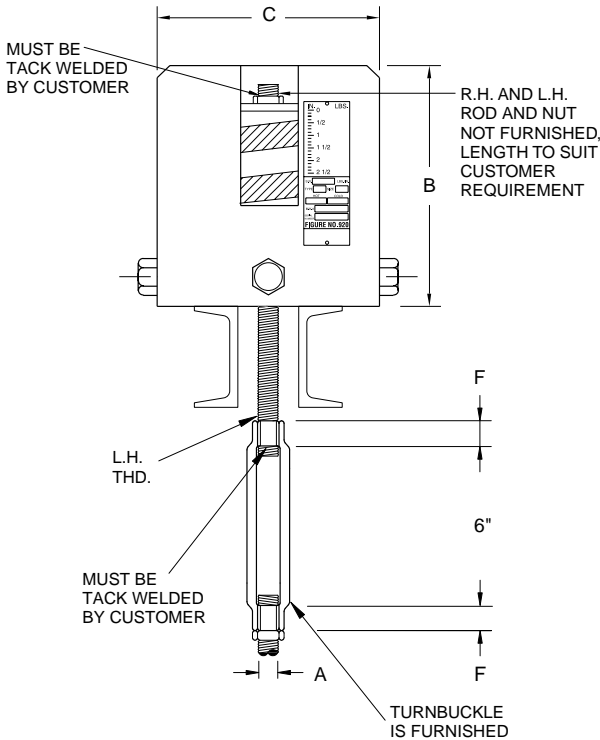

HANGER SIZE	ROD SIZE A	CASE LENGTH B	CASE DIAMETER C	MIN. THD. ENGMT F	APPROX. WEIGHT EACH
000	1/2	8	4	7/8	6
000	M12	203	102	22	2.7
00	1/2	9 1/4	4	7/8	7
00	M12	235	102	22	3.2
0	1/2	9 7/8	4	7/8	8
0	M12	251	102	22	3.6
1	1/2	9 7/8	4	7/8	9
1	M12	251	102	22	4.1
2	1/2	9 7/8	4	7/8	10
2	M12	251	102	22	4.5
3	1/2	10	5 1/16	7/8	14
3	M12	254	141	22	6.4
4	1/2	10	5 1/16	7/8	16
4	M12	254	141	22	7.3
5	1/2	10	5 1/16	7/8	19
5	M12	254	141	22	8.6
6	5/8	11 3/4	6 5/8	1 1/8	25
6	M16	298	168	29	11
7	5/8	11 3/4	6 5/8	1 1/8	25
7	M16	298	168	29	11
8	5/8	11 3/4	6 5/8	1 1/8	29
8	M16	298	168	29	13
9	3/4	12 1/2	8 5/8	1 1/4	50
9	M20	318	219	32	23
10	3/4	13 3/4	8 5/8	1 1/4	54
10	M20	349	219	32	24
11	3/4	12 1/2	8 5/8	1 1/4	64
11	M20	318	219	32	29
12	1	13	8 5/8	1 5/8	70
12	M24	330	219	41	32
13	1	15 5/8	8 5/8	1 5/8	79
13	M24	397	219	41	36
14	1 1/4	16 1/2	8 5/8	1 3/4	84
14	M30	419	219	44	38
15	1 1/4	16 1/2	8 5/8	1 3/4	111
15	M30	419	219	44	50
16	1 1/2	19	8 5/8	2	142
16	M36	483	219	51	64
17	1 3/4	21 1/4	8 5/8	2 5/8	190
17	M36	540	219	67	86
18	2	20 3/4	12 3/4	2 7/8	311
18	M48	527	324	73	141
19	2 1/4	23 1/2	12 3/4	3 1/2	348
19	M56	597	324	89	158
20	2 1/2	29 1/4	12 3/4	3 7/8	487
20	M64	743	324	98	221
21	2 3/4	32 3/8	12 3/4	4 1/4	534
21	M72	822	324	108	242
22	3	38 5/8	12 3/4	4 1/4	714
22	M80x6	981	324	108	324

Ordering: Specify Figure Number (Travel Series), Type, Size, Hot Load, Cold Load, Movement and Direction of Movement (from the Cold/Installed position to the Hot/Operating position), and Hanger Identification Number (if any). Specify any other optional feature(s) as necessary.

For corrosion resistant units specify the Figure Number with the letter prefix "C", e.g. C920

For metric units specify the Figure Number with the letter prefix "M" e.g. M920 or MC920.

DIMENSIONS		TEMPERATURE	LOADS	WEIGHT
INCHES	FAHRENHEIT		POUNDS	POUNDS
MILLIMETERS	CELSIUS		NEWTONS	KILOGRAMS

VARIABLE SPRING SUPPORTS

SERIES 920 - TYPE F

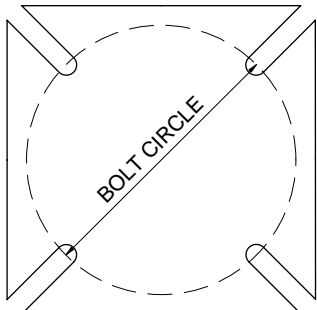
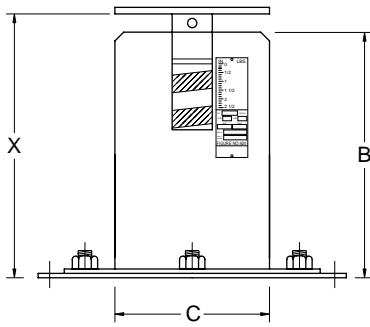

SIZE	CASE LENGTH B	CASE DIA. C	BOTTOM FLANGE BOLT DIA.	BOTTOM FLANGE	BOLT CIRCLE		OVERALL LENGTH X **		LOAD FLANGE DIA.	LOAD FLANGE THICK.	APPROX. WEIGHT EACH
					MIN.	MAX.	MIN.	MAX.			
000	6¼	4	⅝	¼ x 7½ x 7½	7	9¾	7¾	9¾	3⅞	¼	11
000	159	102	16	6 x 190 x 190	178	248	197	248	98	6	5
00	7½	4	⅝	¼ x 7½ x 7½	7	9¾	9	11	3⅞	¼	12
00	191	102	16	6 x 190 x 190	178	248	229	279	98	6	5.4
0	6¾	4	⅝	¼ x 7½ x 7½	7	9¾	8¼	10¼	3⅞	¼	15
0	171	102	16	6 x 190 x 190	178	248	210	260	98	6	6.8
1	7⅞	4	⅝	¼ x ½ x 7½	7	9¾	9⅞	11⅞	3⅞	¼	15
1	194	102	16	6 x 190 x 190	178	248	232	283	98	6	6.8
2	8⅞	4	⅝	¼ x 7½ x 7½	7	9¾	9⅞	11⅞	3⅞	¼	16
2	213	102	16	6 x 190 x 190	178	248	251	302	98	6	7.3
3	7⅞	5⅛	¾	¼ x 7½ x 7½	7¾	9¾	9⅞	11⅞	5⅞	¼	23
3	194	141	19	6 x 190 x 190	197	248	232	283	137	6	10
4	8¼	5⅛	¾	¼ x 7½ x 7½	7¾	9¾	9¾	11¼	5⅞	¼	26
4	210	141	19	6 x 190 x 190	197	248	248	298	137	6	12
5	8⅞	5⅛	¾	¼ x 7½ x 7½	7¾	9¾	10⅞	12⅞	5⅞	¼	27
5	225	141	19	6 x 190 x 190	197	248	264	314	137	6	12
6	8⅞	6⅝	¾	⅜ x 9 x 9	9⅞	11½	10⅞	12⅞	6⅞	¼	42
6	213	168	19	10 x 229 x 229	233	292	257	308	162	6	19
7	9¾	6⅝	¾	⅜ x 9 x 9	9⅞	11½	11⅞	13⅞	6⅞	¼	42
7	248	168	19	10 x 229 x 229	233	292	295	346	162	6	19
8	10¼	6⅝	¾	⅜ x 9 x 9	9⅞	11½	12	14	6⅞	¼	46
8	260	168	19	10 x 229 x 229	233	292	305	356	162	6	21
9	10½	8⅞	¾	½ x 13¼ x 13¼	10⅞	16¼	12½	14½	8⅞	½	83
9	267	219	19	13 x 337 x 337	268	413	318	368	213	13	38
10	11¼	8⅞	¾	½ x 13¼ x 13¼	10⅞	16¼	13¼	15¼	8⅞	½	88
10	298	219	19	13 x 337 x 337	268	413	349	400	213	13	40
11	9⅞	8⅞	¾	½ x 13¼ x 13¼	10⅞	16¼	11⅞	13⅞	8⅞	½	93
11	244	219	19	13 x 337 x 337	268	413	295	346	213	13	42
12	10⅞	8⅞	¾	½ x 13¼ x 13¼	10⅞	16¼	12⅞	14⅞	8⅞	½	100
12	257	219	19	13 x 337 x 337	268	413	308	359	213	13	45
13	12¾	8⅞	¾	½ x 13¼ x 13¼	10⅞	16¼	14¾	16¾	8⅞	½	104
13	324	219	19	13 x 337 x 337	268	413	375	425	213	13	47
14	12⅞	8⅞	¾	½ x 13¼ x 13¼	10⅞	16¼	14⅞	16⅞	8⅞	½	110
14	327	219	19	13 x 337 x 337	268	413	378	429	213	13	50
15	13⅞	8⅞	¾	½ x 13¼ x 13¼	10⅞	16¼	15⅞	17⅞	8⅞	½	134
15	333	219	19	13 x 337 x 337	268	413	384	435	213	13	61
16	15½	8⅞	¾	½ x 13¼ x 13¼	10⅞	16¼	17½	19½	8⅞	½	162
16	394	219	19	13 x 337 x 337	268	413	445	495	213	13	73
17	17½	8⅞	¾	½ x 13¼ x 13¼	10⅞	16¼	19½	21½	8⅞	½	203
17	445	219	19	13 x 337 x 337	268	413	495	546	213	13	92
18	17⅞	12¾	¾	⅝ x 17¼ x 17¼	15¾	21	19½	21½	12½	½	337
18	441	324	19	16 x 438 x 438	400	533	495	546	318	13	153
19	19⅞	12¾	¾	⅝ x 17¼ x 17¼	15¾	21	21¾	23¾	12½	½	366
19	498	324	19	16 x 438 x 438	400	533	552	603	318	13	166
20	22⅞	12¾	¾	⅝ x 17¼ x 17¼	15¾	21	25	27	12½	½	485
20	581	324	19	16 x 438 x 438	400	533	635	686	318	13	220
21	25	12¾	¾	⅝ x 17¼ x 17¼	15¾	21	27¾	29¾	12½	½	513
21	635	324	19	16 x 438 x 438	400	533	705	756	318	13	233
22	31½	12¾	¾	⅝ x 17¼ x 17¼	15¾	21	34⅞	36⅞	12½	½	675
22	800	324	19	16 x 438 x 438	400	533	867	918	318	13	306

** The Installed Height should be the mid-point between the Maximum and Minimum Overall Height "X" , plus the thickness of the Load Flange, and plus any DOWN piping movement when applicable.

Ordering: Specify Figure Number (Travel Series), Type, Size, Hot Load, Cold Load, Movement and Direction of Movement (from the Cold/Installed position to the Hot/Operating position), Dimension X (Installed Height) and Hanger Identification Number (if any). Specify any other optional feature(s) as necessary.

For corrosion resistant units specify the Figure Number with the letter prefix "C", e.g. C920

For metric units specify the Figure Number with the letter prefix "M" e.g. M920 or MC920.

DIMENSIONS		TEMPERATURE	LOADS	WEIGHT
INCHES	FAHRENHEIT		POUNDS	POUNDS
MILLIMETERS	CELSIUS		NEWTONS	KILOGRAMS

VARIABLE SPRING SUPPORTS

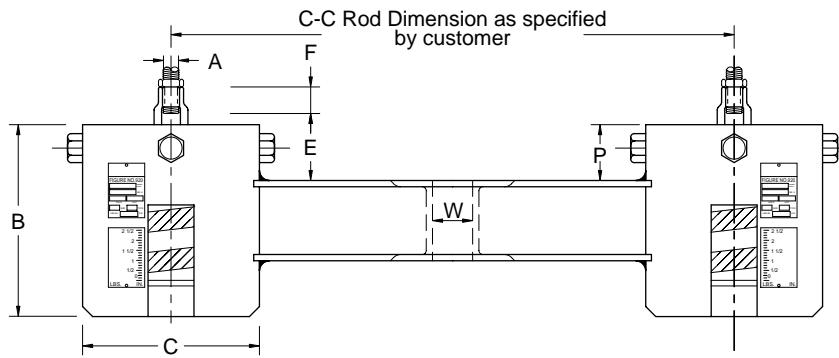

Ordering: Specify Figure Number (Travel Series), Type, Size, Total Load, Hot Load per spring, Cold Load per spring, Movement and Direction of Movement (from the Cold/Installed position to the Hot/Operating position), Center to Center of Rods dimension and Hanger Identification Number (if any). Specify any other optional feature(s) as necessary.

For corrosion resistant units specify the Figure Number with the letter prefix "C", e.g. C920

For metric units specify the Figure Number with the letter prefix "M" e.g. M920 or MC920.

FIGURE 920 - TYPE G

HANGER SIZE	ROD SIZE A	CASE LENGTH B	CASE DIAMETER C	ROD TAKEOUT E	MIN. THD. ENGMT F	CHANNEL SIZE	MAX. C - C	CHANNEL SPACING W	P	APPROX. WEIGHT EACH
000	1/2	8	4	15/8	7/8	C3 x 4.1	24	5/8	1 1/2	24
000	M12	203	102	41	22	C75 x 6	610	16	38	11
00	1/2	9 1/4	4	1 3/8	7/8	C3 x 4.1	24	5/8	1 1/2	26
00	M12	2350	102	35	22	C75 x 6	610	16	38	12
0	1/2	9 7/8	4	1 3/8	7/8	C3 x 4.1	24	5/8	1 1/2	30
0	M12	251	102	35	22	C75 x 6	610	16	38	14
1	1/2	9 7/8	4	1 3/8	7/8	C3 x 4.1	24	5/8	1 1/2	30
1	M12	251	102	35	22	C75 x 6	610	16	38	14
2	1/2	9 7/8	4	1 3/8	7/8	C3 x 4.1	24	5/8	1 1/2	33
2	M12	251	102	35	22	C75 x 6	610	16	38	15
3	1/2	10	5 1/16	1 7/8	7/8	C3 x 4.1	30	3/4	2	41
3	M12	254	141	48	22	C75 x 6	762	19	51	19
4	1/2	10	5 1/16	1 7/8	7/8	C3 x 4.1	30	3/4	2	46
4	M12	254	141	48	22	C75 x 6	762	19	51	21
5	1/2	10	5 1/16	1 7/8	7/8	C3 x 4.1	30	3/4	2	51
5	M12	254	141	48	22	C75 x 6	762	19	51	23
6	5/8	11 3/4	6 5/8	1 13/16	1 1/8	C3 x 4.1	36	1	2	63
6	M16	298	168	46	29	C75 x 6	914	25	51	29
7	5/8	11 3/4	6 5/8	1 13/16	1 1/8	C3 x 4.1	36	1	2	62
7	M16	298	168	46	29	C75 x 6	914	25	51	28
8	5/8	11 3/4	6 5/8	1 13/16	1 1/8	C3 x 4.1	36	1	2	71
8	M16	298	168	46	29	C75 x 6	914	25	51	32
9	3/4	12 1/2	8 5/8	2 7/8	1 1/4	C4 x 5.4	36	1 1/4	3	113
9	M20	318	219	73	32	C100 x 8	914	32	76	51
10	3/4	13 3/4	8 5/8	2 7/8	1 1/4	C4 x 5.4	36	1 1/4	3	123
10	M20	349	219	73	32	C100 x 8	914	32	76	56
11	3/4	12 1/2	8 5/8	2 7/8	1 1/4	C4 x 5.4	36	1 1/4	3	143
11	M20	318	219	73	32	C100 x 8	914	32	76	65
12	1	13	8 5/8	3 7/8	1 5/8	C5 x 6.7	36	1 1/2	4	161
12	M24	330	219	98	41	C130 x 10	914	38	102	73
13	1	15 5/8	8 5/8	3 7/8	1 5/8	C5 x 6.7	36	1 1/2	4	182
13	M24	397	219	98	41	C130 x 10	914	38	102	83
14	1 1/4	16 1/2	8 5/8	3 13/16	1 3/4	C5 x 6.7	33	1 1/2	4	191
14	M30	419	219	97	44	C130 x 10	838	38	102	87
15	1 1/4	16 1/2	8 5/8	3 13/16	1 3/4	C8 x 11.5	36	2 1/8	4	260
15	M30	419	219	97	44	C200 x 17	914	54	102	118
16	1 1/2	19	8 5/8	3 7/8	2	C8 x 11.5	36	2 1/8	4	327
16	M36	483	219	98	51	C200 x 17	914	54	102	148
17	1 3/4	21 1/4	8 5/8	3 5/8	2 5/8	C8 x 11.5	36	2 1/8	4	437
17	M42	540	219	92	67	C200 x 17	914	54	102	198
18	2	20 3/4	12 3/4	3 7/8	2 7/8	C12 x 20.7	42	2 3/8	4	691
18	M48	527	324	98	73	C130 x 31	1067	67	102	313
19	2 1/4	23 1/2	12 3/4	3 7/8	3 1/2	C12 x 20.7	42	2 5/8	4	778
19	M56	597	324	98	89	C130 x 31	1067	67	102	353
20	2 1/2	29 1/4	12 3/4	3 7/8	3 7/8	C12 x 20.7	40	2 5/8	4	1081
20	M64	743	324	98	98	C130 x 31	1016	67	102	490
21	2 3/4	32 3/8	12 3/4	3 7/8	4 1/4	C15 x 33.9	48	3 1/8	4	1216
21	M72	822	324	98	108	C380 x 50	1219	79	102	552
22	3	38 5/8	12 3/4	4 1/4	4 1/4	C15 x 33.9	48	3 3/8	4	1632
22	M80x6	981	324	108	108	C380 x 50	1219	86	102	740

DIMENSIONS		TEMPERATURE	LOADS	WEIGHT
INCHES	FARENHEIT	POUNDS	POUNDS	
MILLIMETERS	CELSIUS	NEWTONS	KILOGRAMS	

VARIABLE SPRING SUPPORTS

SERIES 940 - TYPE A

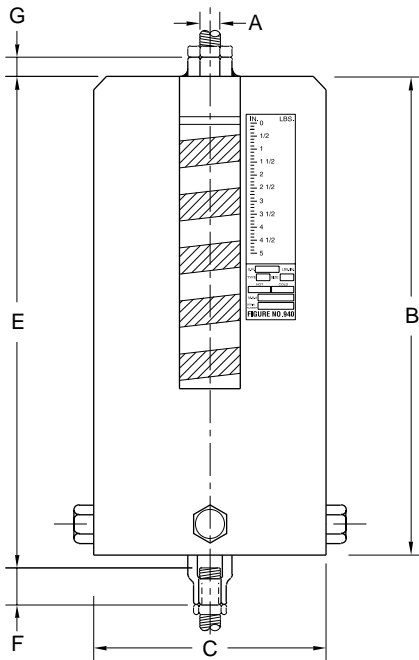

SIZE	ROD SIZE A	CASE LGTH B	CASE DIA. C	ROD T'OUT E	MIN. THD. ENGM'T F	ROD ENGM'T G	APPROX. WGT EACH
0	1/2	14 1/4	4	14 1/8	7/8	7/8	16
0	M12	362	102	359	22	22	7.3
1	1/2	16	4	15 7/8	7/8	7/8	17
1	M12	406	102	403	22	22	7.7
2	1/2	17 1/2	4	17 3/8	7/8	7/8	19
2	M12	445	102	441	22	22	8.6
3	1/2	15 1/2	5 9/16	15 3/8	7/8	7/8	26
3	M12	394	141	391	22	22	12
4	1/2	17	5 9/16	16 7/8	7/8	7/8	31
4	M12	432	141	429	22	22	14
5	1/2	18	5 9/16	17 7/8	7/8	7/8	34
5	M12	457	141	454	22	22	15
6	5/8	18 3/8	6 3/8	18 1/4	1 1/8	1 1/8	45
6	M16	467	168	464	29	29	20
7	5/8	20	6 3/8	20	1 1/8	1 1/8	44
7	M16	508	168	508	29	29	20
8	5/8	21	6 3/8	21 1/8	1 1/8	1 1/8	53
8	M16	533	168	537	29	29	24
9	3/4	21	8 3/8	20 7/8	1 1/4	1 1/4	87
9	M20	533	219	530	32	32	39
10	3/4	24 1/4	8 3/8	24 1/8	1 1/4	1 1/4	97
10	M20	616	219	613	32	32	44
11	3/4	19 1/2	8 3/8	19 3/8	1 1/4	1 1/4	115
11	M20	495	219	492	32	32	52
12	1	21 1/2	8 3/8	21 3/8	1 3/8	1 3/8	129
12	M24	546	219	543	41	41	59
13	1	27	8 3/8	26 7/8	1 3/8	1 3/8	146
13	M24	686	219	683	41	41	66
14	1 1/4	27 3/4	8 3/8	27 1/2	1 3/4	1 3/4	156
14	M30	705	219	699	44	44	71
15	1 1/4	27 3/8	8 3/8	27 1/4	1 3/4	1 3/4	212
15	M30	695	219	692	44	44	96
16	1 1/2	32 5/8	8 3/8	32 1/2	2	2	280
16	M36	829	219	826	51	51	127
17	1 3/4	37	8 3/8	36 3/8	2 3/8	2 3/8	374
17	M42	940	219	930	67	67	170
18	2	36 1/2	12 3/4	36 3/8	2 7/8	2 7/8	570
18	M48	927	324	924	73	73	259
19	2 1/4	42 1/8	12 3/4	42	3 1/2	3 1/2	661
19	M56	1070	324	1067	89	89	300
20	2 1/2	49 1/2	12 3/4	49 3/8	3 7/8	3 7/8	943
20	M64	1257	324	1254	98	98	428
21	2 3/4	54 5/8	12 3/4	54 1/2	4 1/4	4 1/4	1036
21	M72	1387	324	1384	108	108	470
22	3	67	12 3/4	67 1/4	4 1/4	4 1/4	1423
22	M80x6	1702	324	1708	108	108	645

Ordering: Specify Figure Number (Travel Series), Type, Size, Hot Load, Cold Load, Movement and Direction of Movement (from the Cold/Installed position to the Hot/Operating position), and Hanger Identification Number (if any). Specify any other optional feature(s) as necessary.

For corrosion resistant units specify the Figure Number with the letter prefix "C", e.g. C940

For metric units specify the Figure Number with the letter prefix "M" e.g. M940 or MC940.

DIMENSIONS		TEMPERATURE	LOADS	WEIGHT
INCHES	FAHRENHEIT		POUNDS	POUNDS
MILLIMETERS	CELSIUS		NEWTONS	KILOGRAMS

FIGURE 940 TYPE B

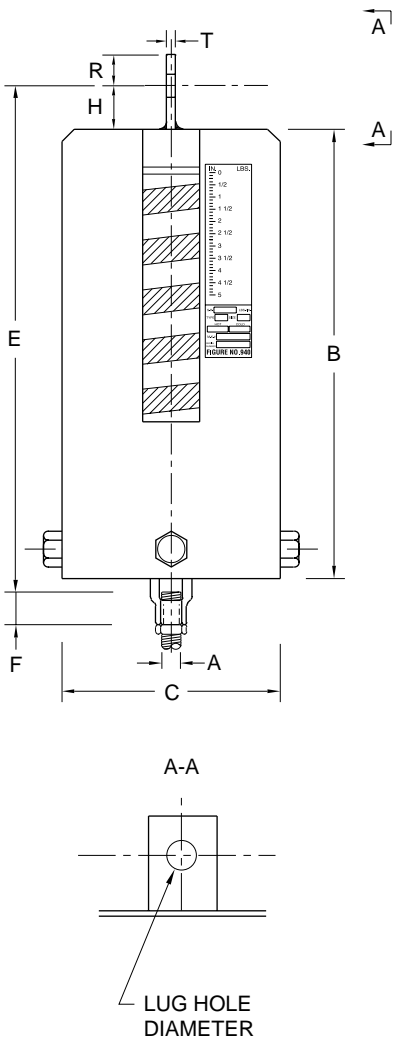

SIZE	ROD SIZE A	CASE LGTH. B	CASE DIA. C	ROD T'OUT E	MIN. THD. ENGM'T F	HGT. OF PIN H	R	T	LUG HOLE DIA.	APPROX. WGT. EACH
0	1/2	14 1/4	4	15 5/8	7/8	1 1/2	1/4	1/4	1 1/16	16.
0	M12	362	102	397	22	38	32	6	17	7.3
1	1/2	16	4	17 3/8	7/8	1 1/2	1/4	1/4	1 1/16	17
1	M12	406	102	441	22	38	32	6	17	7.7
2	1/2	17 1/2	4	18 3/8	7/8	1 1/2	1/4	1/4	1 1/16	19
2	M12	445	102	479	22	38	32	6	17	8.6
3	1/2	15 1/2	5 9/16	16 7/8	7/8	1 1/2	1/4	1/4	1 1/16	26
3	M12	394	141	429	22	38	32	6	17	12
4	1/2	17	5 9/16	18 3/8	7/8	1 1/2	1/4	1/4	1 1/16	31
4	M12	432	141	467	22	38	32	6	17	14
5	1/2	18	5 9/16	19 3/8	7/8	1 1/2	1/4	1/4	1 1/16	34
5	M12	457	141	492	22	38	32	6	17	15
6	5/8	18 3/8	6 5/8	19 3/4	1 1/8	1 1/2	1/4	1/4	1 3/16	45
6	M16	467	168	502	29	38	32	6	21	20
7	5/8	20	6 5/8	21 1/2	1 1/8	1 1/2	1/4	1/4	1 3/16	44
7	M16	508	168	546	29	38	32	6	21	20
8	5/8	21 1/4	6 5/8	22 1/2	1 1/8	1 1/2	1/4	1/4	1 3/16	53
8	M16	540	168	572	29	38	32	6	21	24
9	3/4	21	8 5/8	22 3/8	1 1/4	1 1/2	1/4	3/8	1 5/16	87
9	M20	533	219	568	32	38	32	10	24	39
10	3/4	24 3/4	8 5/8	25 5/8	1 1/4	1 1/2	1/4	3/8	1 5/16	97
10	M20	616	219	651	32	38	32	10	24	44
11	3/4	19 1/2	8 5/8	20 7/8	1 1/4	1 1/2	1/4	3/8	1 5/16	115
11	M20	495	219	530	32	38	32	10	24	52
12	1	21 1/2	8 5/8	23 3/8	1 5/8	2	1 1/2	1/2	1 1/4	129
12	M24	546	219	594	41	51	38	13	32	59
13	1	27	8 5/8	28 7/8	1 5/8	2	1 1/2	1/2	1 1/4	146
13	M24	686	219	733	41	51	38	13	32	66
14	1 1/4	27 3/4	8 5/8	30 1/2	1 3/4	3	2	5/8	1 1/2	156
14	M30	705	219	775	44	76	51	16	38	71
15	1 1/4	27 3/8	8 5/8	30 3/4	1 3/4	3	2	5/8	1 1/2	212
15	M30	695	219	768	44	76	51	16	38	96
16	1 1/2	32 5/8	8 5/8	35 1/2	2	3	2 1/2	3/4	1 3/4	280
16	M36	829	219	902	51	76	64	19	44	127
17	1 3/4	37	8 5/8	39 5/8	2 5/8	3	2 1/2	3/4	2	374
17	M42	940	219	1006	67	76	64	19	51	170
18	2	36 1/2	12 3/4	40 3/8	2 7/8	4	3	3/4	2 3/8	570
18	M48	927	324	1026	73	102	76	19	60	259
19	2 1/4	42 1/8	12 3/4	46	3 1/2	4 1/2	3	3/4	2 5/8	661
19	M56	1070	324	1168	89	114	76	19	67	300
20	2 1/2	49 1/2	12 3/4	53 7/8	3 7/8	4 1/2	4	1	2 7/8	943
20	M64	1257	324	1368	98	114	102	25	73	428
21	2 3/4	54 5/8	12 3/4	59	4 1/4	4 1/2	4	1	3 1/8	1036
21	M72	1387	324	1499	108	114	102	25	79	470
22	3	67	12 3/4	72 1/4	4 1/4	5	4	1	3 3/8	1423
22	M80x6	1702	324	1835	108	127	102	25	86	645

Ordering: Specify Figure Number (Travel Series), Type, Size, Hot Load, Cold Load, Movement and Direction of Movement (from the Cold/Installed position to the Hot/Operating position), and Hanger Identification Number (if any). Specify any other optional feature(s) as necessary.

Pins for attachment to the structure are not included with the unit and must be ordered separately as a Figure 291, shown on page 8 of this catalog. For ordering specify Figure Number, pin diameter and finish.

For corrosion resistant units specify the Figure Number with the letter prefix "C", e.g. C910

For metric units specify the Figure Number with the letter prefix "M" e.g. M910 or MC910.

DIMENSIONS		TEMPERATURE	LOADS		WEIGHT
INCHES	FAHRENHEIT		POUNDS	POUNDS	
MILLIMETERS	CELSIUS		NEWTONS	KILOGRAMS	

SERIES 940 - TYPE C

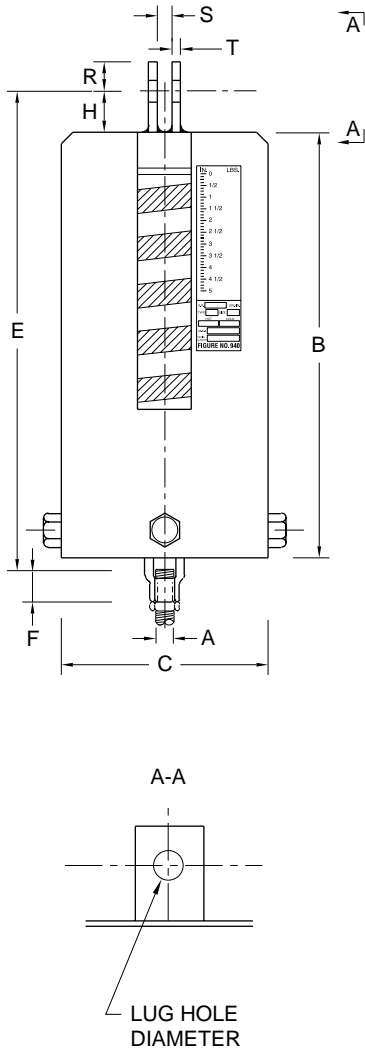

SIZE	ROD SIZE A	CASE LGTH. B	CASE DIA. C	ROD T'OUT E	MIN. THD. ENGM'T F	HGT. OF PIN H	R	S	T	LUG HOLE DIA.	APPROX. WGT EACH
0	1/2	14 1/4	4	15 5/8	7/8	1 1/2	1 1/4	1 1/4	1/4	1 1/16	16
0	M12	362	102	397	22	38	32	32	6	17	7.3
1	1/2	16	4	17 3/8	7/8	1 1/2	1 1/4	1 1/4	1/4	1 1/16	17
1	M12	406	102	441	22	38	32	32	6	17	7.7
2	1/2	17 1/2	4	18 7/8	7/8	1 1/2	1 1/4	1 1/4	1/4	1 1/16	19
2	M12	445	102	479	22	38	32	32	6	17	8.6
3	1/2	15 1/2	5 1/16	16 7/8	7/8	1 1/2	1 1/4	1 1/4	1/4	1 1/16	26
3	M12	394	141	429	22	38	32	32	6	17	12
4	1/2	17	5 1/16	18 3/8	7/8	1 1/2	1 1/4	1 1/4	1/4	1 1/16	31
4	M12	432	141	467	22	38	32	32	6	17	14
5	1/2	18	5 1/16	19 3/8	7/8	1 1/2	1 1/4	1 1/4	1/4	1 1/16	34
5	M12	457	141	492	22	38	32	32	6	17	15
6	5/8	18 3/8	6 5/8	19 3/4	1 1/8	1 1/2	1 1/4	1 1/4	1/4	1 3/16	45
6	M16	467	168	502	29	38	32	32	6	21	20
7	5/8	20	6 5/8	21 1/2	1 1/8	1 1/2	1 1/4	1 1/4	1/4	1 3/16	44
7	M16	508	168	546	29	38	32	32	6	21	20
8	5/8	21	6 5/8	21 1/2	1 1/8	1 1/2	1 1/4	1 1/4	1/4	1 3/16	53
8	M16	533	168	572	29	38	32	32	6	21	24
9	3/4	21	8 5/8	22 3/8	1 1/4	1 1/2	1 1/4	1 1/4	3/8	1 5/16	87
9	M20	533	219	568	32	38	32	32	10	24	39
10	3/4	24 1/4	8 5/8	25 5/8	1 1/4	1 1/2	1 1/4	1 1/4	3/8	1 5/16	97
10	M20	616	219	651	32	38	32	32	10	24	44
11	3/4	19 1/2	8 5/8	20 7/8	1 1/4	1 1/2	1 1/4	1 1/4	3/8	1 5/16	115
11	M20	495	219	530	32	38	32	32	10	24	52
12	1	21 1/2	8 5/8	23 3/8	1 5/8	2	1 1/2	1 3/8	1/2	1 1/4	129
12	M24	546	219	594	41	51	38	41	13	32	59
13	1	27	8 5/8	28 7/8	1 5/8	2	1 1/2	1 3/8	1/2	1 1/4	146
13	M24	686	219	733	41	51	38	41	13	32	66
14	1 1/4	27 3/4	8 5/8	30 1/2	1 3/4	3	2	2	5/8	1 1/2	156
14	M30	705	219	775	44	76	51	51	16	38	710
15	1 1/4	27 3/8	8 5/8	30 1/4	1 3/4	3	2	2	5/8	1 1/2	212
15	M30	695	219	768	44	76	51	51	16	38	96
16	1 1/2	32 5/8	8 5/8	35 1/2	2	3	2 1/2	2 3/8	3/4	1 3/4	280
16	M36	829	219	902	51	76	64	60	19	44	127
17	1 3/4	37	8 5/8	39 5/8	2 5/8	3	2 1/2	2 3/8	3/4	2	374
17	M42	940	219	1006	67	76	64	60	19	51	170
18	2	36 1/2	12 3/4	40 3/8	2 7/8	4	3	2 7/8	3/4	2 3/8	570
18	M48	927	324	1026	73	102	76	73	19	60	259
19	2 1/4	42 1/8	12 3/4	46	3 1/2	4 1/2	3	3 1/8	3/4	2 5/8	661
19	M56	1070	324	1168	89	114	76	79	19	67	300
20	2 1/2	49 1/2	12 3/4	53 7/8	3 7/8	4 1/2	4	3 3/8	1	2 7/8	943
20	M64	1257	324	1368	98	114	102	86	25	73	428
21	2 3/4	54 5/8	12 3/4	59	4 1/4	4 1/2	4	3 5/8	1	3 3/8	1036
21	M72	1387	324	1499	108	114	102	92	25	79	470
22	3	67	12 3/4	72 1/4	4 1/4	5	4	3 7/8	1	3 3/8	1423
22	M80x6	1702	324	1835	108	127	102	98	25	86	645

Ordering: Specify Figure Number (Travel Series), Type, Size, Hot Load, Cold Load, Movement and Direction of Movement (from the Cold/Installed position to the Hot/Operating position), and Hanger Identification Number (if any). Specify any other optional feature(s) as necessary.

Pins for attachment to the structure are not included with the unit and must be ordered separately as a Figure 291, shown on page 8 of this catalog. For ordering specify Figure Number, pin diameter and finish.

For corrosion resistant units specify the Figure Number with the letter prefix "C", e.g. C910

For metric units specify the Figure Number with the letter prefix "M" e.g. M910 or MC910.

DIMENSIONS		TEMPERATURE	LOADS	WEIGHT
INCHES	FAHRENHEIT		POUNDS	POUNDS
MILLIMETERS	CELSIUS		NEWTONS	KILOGRAMS

SERIES 940 TYPE D

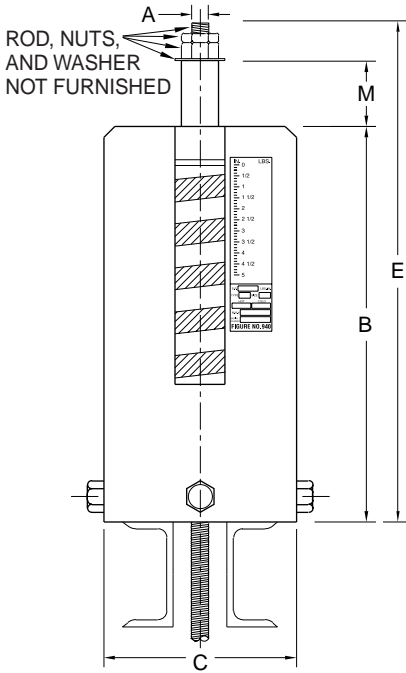

HANGER SIZE	ROD SIZE A	CASE LENGTH B	CASE DIA. C	HGT. OF SPACER E	ROD TAKEOUT M	APPROX. WEIGHT EACH
0	1/2	14 1/4	4	22 1/2	7 1/2	15
0	M12	362	102	572	191	6.8
1	1/2	16	4	24 1/4	7 1/2	15
1	M12	406	102	616	191	6.8
2	1/2	17 1/2	4	25 3/4	7 1/2	18
2	M12	445	102	654	191	8.2
3	1/2	15 1/2	5 9/16	23 3/4	7 1/2	24
3	M12	394	141	635	191	11
4	1/2	17	5 9/16	25 1/4	7 1/2	29
4	M12	432	141	641	191	13
5	1/2	18	5 9/16	26 1/4	7 1/2	32
5	M12	457	141	667	191	15
6	5/8	18 3/8	6 5/8	26 3/4	7 1/2	43
6	M16	467	168	679	191	20
7	5/8	20	6 5/8	28 1/4	7 1/2	42
7	M16	508	168	718	191	19
8	5/8	21	6 5/8	29 7/8	7 7/8	51
8	M16	533	168	759	200	23
9	3/4	21	8 5/8	30	7 7/8	84
9	M20	533	219	762	200	38
10	3/4	24 1/4	8 5/8	33 1/4	7 7/8	94
10	M20	616	219	845	200	43
11	3/4	19 1/2	8 5/8	28 1/2	7 7/8	96
11	M20	495	219	724	200	44
12	1	21 1/2	8 5/8	31 1/8	8 1/8	103
12	M24	546	219	791	206	47
13	1	27	8 5/8	36 5/8	8 1/8	139
13	M24	686	219	930	206	63
14	1 1/4	27 3/4	8 5/8	38 1/8	8 1/2	149
14	M30	705	219	968	216	68
15	1 1/4	27 3/8	8 5/8	37 5/8	8 3/8	200
15	M30	695	219	956	213	91
16	1 1/2	32 5/8	8 5/8	43 5/8	8 3/4	261
16	M36	829	219	1108	222	118
17	1 3/4	37	8 5/8	48 7/8	9 1/4	343
17	M42	940	219	1241	235	156
18	2	36 1/2	12 3/4	45 1/4	5 3/4	533
18	M48	927	324	1149	146	242
19	2 1/4	42 1/8	12 3/4	51 1/2	6	615
19	M56	1070	324	1308	152	279
20	2 1/2	49 1/2	12 3/4	59 1/4	6	850
20	M64	1257	324	1505	152	386
21	2 3/4	54 5/8	12 3/4	65	6 1/4	937
21	M72	1387	324	1651	159	425
22	3	67	12 3/4	76 1/2	5	1277
22	M80x6	1702	324	1943	127	579

Ordering: Specify Figure Number (Travel Series), Type, Size, Hot Load, Cold Load, Movement and Direction of Movement (from the Cold/Installed position to the Hot/Operating position), and Hanger Identification Number (if any). Specify any other optional feature(s) as necessary.

For corrosion resistant units specify the Figure Number with the letter prefix "C", e.g. C940

For metric units specify the Figure Number with the letter prefix "M" e.g. M940 or MC940.

DIMENSIONS		TEMPERATURE	LOADS	WEIGHT
INCHES	FAHRENHEIT	POUNDS	POUNDS	
MILLIMETERS	CELSIUS	NEWTONS	KILOGRAMS	

SERIES 940 TYPE E

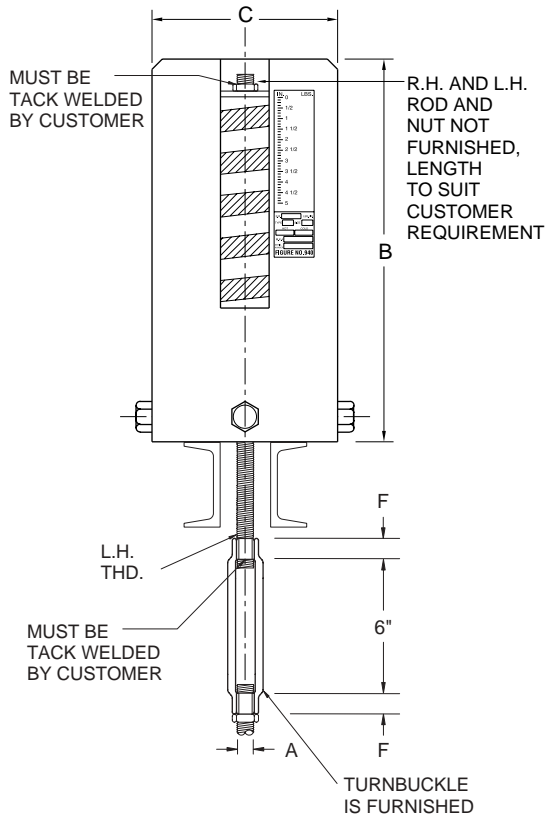

HANGER SIZE	ROD SIZE A	CASE LENGTH B	CASE DIAMETER C	MIN. THD. ENGMT F	APPROX. WEIGHT EACH
0	1/2	14 1/4	4	7/8	15
0	M12	362	102	22	6.8
1	1/2	16	4	7/8	15
1	M12	406	102	22	6.8
2	1/2	17 1/2	4	7/8	18
2	M12	445	102	22	8.2
3	1/2	15 1/2	5 9/16	7/8	24
3	M12	394	141	22	11
4	1/2	17	5 9/16	7/8	29
4	M12	432	141	22	13
5	1/2	18	5 9/16	7/8	32
5	M12	457	141	22	15
6	5/8	18 3/8	6 3/8	1 1/8	43
6	M16	467	168	29	20
7	5/8	20	6 3/8	1 1/8	42
7	M16	508	168	29	19
8	5/8	21	6 3/8	1 1/8	51
8	M16	533	168	29	23
9	3/4	21	8 5/8	1 1/4	84
9	M20	533	219	32	38
10	3/4	24 1/4	8 5/8	1 1/4	94
10	M20	616	219	32	43
11	3/4	19 1/2	8 5/8	1 1/4	96
11	M20	495	219	32	44
12	1	21 1/2	8 5/8	1 5/8	103
12	M24	546	219	41	47
13	1	27	8 5/8	1 5/8	139
13	M24	686	219	41	63
14	1 1/4	27 3/4	8 5/8	1 3/4	149
14	M30	705	219	44	68
15	1 1/4	27 3/8	8 5/8	1 3/4	200
15	M30	695	219	44	91
16	1 1/2	32 5/8	8 5/8	2	261
16	M36	829	219	51	118
17	1 3/4	37	8 5/8	2 5/8	343
17	M42	940	219	67	156
18	2	36 1/2	12 3/4	2 7/8	533
18	M48	927	324	73	242
19	2 1/4	42 1/8	12 3/4	3 1/2	615
19	M56	1070	324	89	279
20	2 1/2	49 1/2	12 3/4	3 7/8	850
20	M64	1257	324	98	386
21	2 3/4	54 5/8	12 3/4	4 1/4	937
21	M72	1387	324	108	425
22	3	67	12 3/4	4 1/4	1277
22	M80X6	1702	324	108	579

Ordering: Specify Figure Number (Travel Series), Type, Size, Hot Load, Cold Load, Movement and Direction of Movement (from the Cold/Installed position to the Hot/Operating position), and Hanger Identification Number (if any). Specify any other optional feature(s) as necessary.

For corrosion resistant units specify the Figure Number with the letter prefix "C", e.g. C940

For metric units specify the Figure Number with the letter prefix "M" e.g. M940 or MC940.

DIMENSIONS	TEMPERATURE	LOADS	WEIGHT
INCHES	FAHRENHEIT	POUNDS	POUNDS
MILLIMETERS	CELSIUS	NEWTONS	KILOGRAMS

SERIES 940 - TYPE F

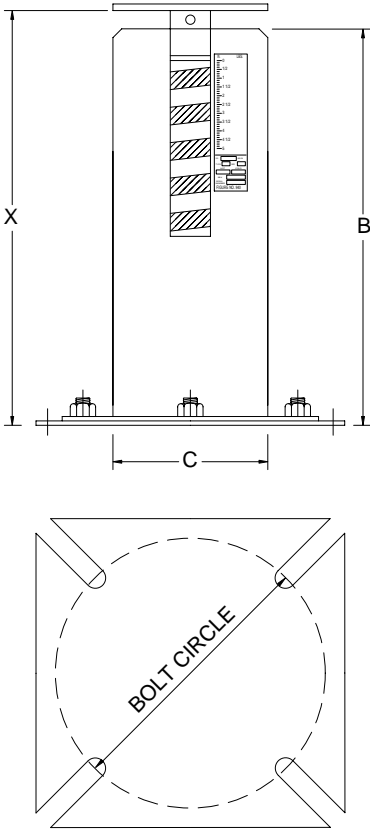

SIZE	CASE LNTH. B	CASE DIA. C	BOTTOM FLANGE BOLT DIA.	BOTTOM FLANGE	BOLT CIRCLE		OVERALL LNTH. X **		LOAD FLANGE DIA.	LOAD FLANGE THICK.	APPROX. WGT. EACH
					MIN.	MAX.	MIN.	MAX.			
0	12¾	4	5/8	¼ x 7½ x 7½	7	9¾	14¼	16¼	3/8	¼	23
0	324	102	16	6 x 191 x 191	178	248	362	413	98	6	10
1	14½	4	5/8	¼ x 7½ x 7½	7	9¾	16	18	3/8	¼	23
1	368	102	16	6 x 191 x 191	178	248	406	457	98	6	10
2	16	4	5/8	¼ x 7½ x 7½	7	9¾	17½	19½	3/8	¼	26
2	406	102	16	6 x 191 x 191	178	248	445	495	98	6	12
3	14⅞	5⅞	¾	¼ x 7½ x 7½	7¾	9¾	15⅞	17⅞	5/8	¼	38
3	359	141	19	6 x 191 x 191	197	248	397	448	137	6	17
4	15½	5⅞	¾	¼ x 7½ x 7½	7¾	9¾	16⅞	18	5/8	¼	43
4	394	141	19	6 x 191 x 191	197	248	429	457	137	6	20
5	16⅞	5⅞	¾	¼ x 7½ x 7½	7¾	9¾	18¼	20⅞	5/8	¼	46
5	429	141	19	6 x 191 x 191	197	248	464	518	137	6	21
6	16⅞	6⅞	¾	¾ x 9 x 9	9¼	10½	18⅞	20⅞	5/8	¼	62
6	422	168	19	10 x 229 x 229	235	267	467	518	137	6	28
7	18½	6⅞	¾	¾ x 9 x 9	9¼	10½	20⅞	22¼	6⅞	¼	61
7	470	168	19	10 x 229 x 229	235	267	518	565	162	6	28
8	19½	6⅞	¾	¾ x 9 x 9	9¼	10½	21¼	23¼	6⅞	¼	70
8	495	168	19	10 x 229 x 229	235	267	540	591	162	6	32
9	19⅞	8⅞	¾	½ x 13¼ x 13¼	10⅞	16¼	21¾	23⅞	8⅞	½	120
9	498	219	19	13 x 337 x 337	268	413	552	600	213	13	54
10	22⅞	8⅞	¾	½ x 13¼ x 13¼	10⅞	16¼	24¼	26⅞	8⅞	½	131
10	562	219	19	13 x 337 x 337	268	413	616	664	213	13	59
11	17¾	8⅞	¾	½ x 13¼ x 13¼	10⅞	16¼	19⅞	21¾	8⅞	½	142
11	451	219	19	13 x 337 x 337	268	413	505	552	213	13	64
12	19	8⅞	¾	½ x 13¼ x 13¼	10⅞	16¼	21⅞	23	8⅞	½	156
12	483	219	19	13 x 337 x 337	268	413	537	584	213	13	71
13	24⅞	8⅞	¾	½ x 13¼ x 13¼	10⅞	16¼	26¼	28⅞	8⅞	½	166
13	613	219	19	13 x 337 x 337	268	413	667	714	213	13	75
14	24⅞	8⅞	¾	½ x 13¼ x 13¼	10⅞	16¼	26½	28⅞	8⅞	½	175
14	619	219	19	13 x 337 x 337	268	413	673	721	213	13	79
15	24½	8⅞	¾	½ x 13¼ x 13¼	10⅞	16¼	26⅞	28½	8⅞	½	224
15	622	219	19	13 x 337 x 337	268	413	676	724	213	13	102
16	29⅞	8⅞	¾	½ x 13¼ x 13¼	10⅞	16¼	31¼	33⅞	8⅞	½	281
16	740	219	19	13 x 337 x 337	268	413	794	841	213	13	127
17	33¼	8⅞	¾	½ x 13¼ x 13¼	10⅞	16¼	35⅞	37¼	8⅞	½	378
17	845	219	19	13 x 337 x 337	268	413	899	946	213	13	171
18	32⅞	12¾	¾	⅝ x 17¼ x 17¼	15¾	21	34⅞	36¼	12½	½	562
18	816	324	19	16 x 438 x 438	400	533	867	921	318	13	255
19	36⅞	12¾	¾	⅝ x 17¼ x 17¼	15¾	21	38⅞	40¼	12½	½	617
19	930	324	19	16 x 438 x 438	400	533	981	1035	318	13	280
20	43⅞	12¾	¾	⅝ x 17¼ x 17¼	15¾	21	46	48	12½	½	855
20	1095	324	19	16 x 438 x 438	400	533	1168	1219	318	13	388
21	48½	12¾	¾	⅝ x 17¼ x 17¼	15¾	21	50⅞	52⅞	12½	½	910
21	1232	324	19	16 x 438 x 438	400	533	1286	1337	318	13	413
22	59⅞	12¾	¾	⅝ x 17¼ x 17¼	15¾	21	62¼	64¼	12½	½	1231
22	1521	324	19	16 x 438 x 438	400	533	1594	1645	318	13	558

** The Installed Height should be the mid-point between the Maximum and Minimum Overall Height "X", plus the thickness of the Load Flange, and plus any DOWN piping movement when applicable.

Ordering: Specify Figure Number (Travel Series), Type, Size, Hot Load, Cold Load, Movement and Direction of Movement (from the Cold/Installed position to the Hot/Operating position), Dimension X (Installed Height) and Hanger Identification Number (if any). Specify any other optional feature(s) as necessary.

For corrosion resistant units specify the Figure Number with the letter prefix "C", e.g. C940
 For metric units specify the Figure Number with the letter prefix "M" e.g. M940 or MC940.

DIMENSIONS		TEMPERATURE	LOADS	WEIGHT
INCHES		FAHRENHEIT	POUNDS	POUNDS
MILLIMETERS		CELSIUS	NEWTONS	KILOGRAMS

VARIABLE SPRING SUPPORTS

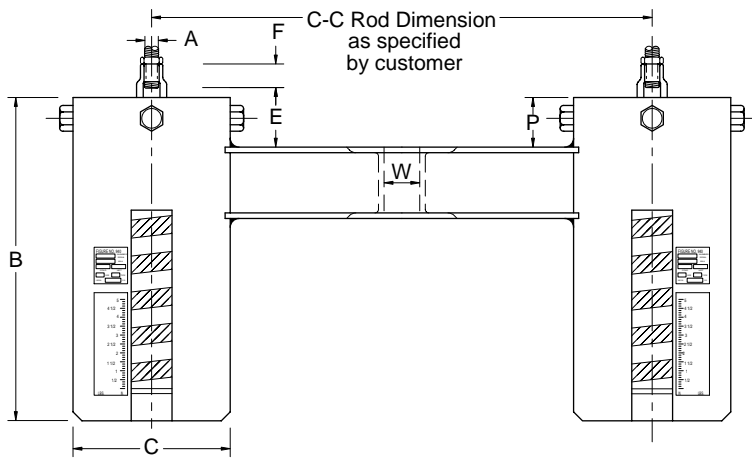

Ordering: Specify Figure Number (Travel Series), Type, Size, Total Load, Hot Load per spring, Cold Load per spring, Movement and Direction of Movement (from the Cold/Installed position to the Hot/Operating position), Center to Center of Rods dimension and Hanger Identification Number (if any). Specify any other optional feature(s) as necessary.

For corrosion resistant units specify the Figure Number with the letter prefix "C", e.g. C940

For metric units specify the Figure Number with the letter prefix "M" e.g. M940 or MC940.

FIGURE 940 TYPE G

HANGER SIZE	ROD SIZE A	CASE LENGTH B	CASE DIAMETER C	ROD TAKEOUT E	MIN. THD. ENGM'T F	CHANNEL SIZE	MAX. C - C	CHANNEL SPACING W	P	APPROX. WEIGHT EACH
0	1/2	14 1/4	4	1 3/8	7/8	C3 x 4.1	24	5/8	1 1/2	42
0	M12	362	102	35	22	C75 x 6	610	16	38	19
1	1/2	16	4	1 3/8	7/8	C3 x 4.1	24	5/8	1 1/2	43
1	M12	406	102	35	22	C75 x 6	610	16	38	20
2	1/2	17 1/2	4	1 3/8	7/8	C3 x 4.1	24	5/8	1 1/2	48
2	M12	445	102	35	22	C75 x 6	610	16	38	22
3	1/2	15 1/2	5 5/16	1 7/8	7/8	C3 x 4.1	30	3/4	2	61
3	M12	394	141	48	22	C75 x 6	762	19	51	28
4	1/2	17	5 5/16	1 7/8	7/8	C3 x 4.1	30	3/4	2	71
4	M12	432	141	48	22	C75 x 6	762	19	51	32
5	1/2	18	5 5/16	1 7/8	7/8	C3 x 4.1	30	3/4	2	77
5	M12	457	141	48	22	C75 x 6	762	19	51	35
6	5/8	18 3/8	6 3/8	1 7/8	1 1/8	C3 x 4.1	36	1	2	100
6	M16	467	168	48	29	C75 x 6	914	25	51	45
7	5/8	20	6 3/8	1 7/8	1 1/8	C3 x 4.1	36	1	2	98
7	M16	508	168	48	29	C75 x 6	914	25	51	44
8	5/8	21	6 3/8	1 7/8	1 1/8	C3 x 4.1	36	1	2	116
8	M16	533	168	48	29	C75 x 6	914	25	51	53
9	3/4	21	8 5/8	2 7/8	1 1/4	C4 x 5.4	36	1 1/4	3	184
9	M20	533	219	73	32	C100 x 8	914	32	76	83
10	3/4	24 1/4	8 5/8	2 7/8	1 1/4	C4 x 5.4	36	1 1/4	3	204
10	M20	616	219	73	32	C100 x 8	914	32	76	93
11	3/4	19 1/2	8 5/8	2 7/8	1 1/4	C4 x 5.4	36	1 1/4	3	241
11	M20	495	219	73	32	C100 x 8	914	32	76	109
12	1	21 1/2	8 5/8	3 3/8	1 5/8	C5 x 6.7	36	1 1/2	4	272
12	M24	546	219	98	41	C130 x 10	914	38	102	123
13	1	27	8 5/8	3 3/8	1 5/8	C5 x 6.7	36	1 1/2	4	304
13	M24	686	219	98	41	C130 x 10	914	38	102	138
14	1 1/4	27 3/4	8 5/8	3 3/8	1 3/4	C5 x 6.7	36	1 1/2	4	324
14	M30	705	219	98	44	C130 x 10	914	38	102	147
15	1 1/4	27 3/8	8 5/8	3 3/8	1 3/4	C8 x 11.5	36	2 1/8	4	445
15	M30	6952	219	98	44	C200 x 17	914	54	102	202
16	1 1/2	32 5/8	8 5/8	3 3/8	2	C8 x 11.5	36	2 1/8	4	573
16	M36	829	219	98	51	C200 x 17	914	54	102	260
17	1 3/4	37	8 5/8	3 3/8	2 3/8	C8 x 11.5	36	2 1/8	4	762
17	M42	940	219	92	67	C200 x 17	914	54	102	346
18	2	36 1/2	12 3/4	3 3/8	2 7/8	C12 x 20.7	42	2 3/8	4	1155
18	M48	927	324	98	73	C130 x 31	1067	60	102	524
19	2 1/4	42 1/8	12 3/4	3 3/8	3 1/2	C12 x 20.7	42	2 5/8	4	1336
19	M56	1070	324	98	89	C130 x 31	1067	67	102	606
20	2 1/2	49 1/2	12 3/4	3 3/8	3 3/8	C12 x 20.7	40	2 7/8	4	1874
20	M64	1257	324	98	98	C130 x 31	1016	73	102	850
21	2 3/4	54 5/8	12 3/4	3 3/8	4 1/4	C15 x 33.9	48	3 1/8	4	2086
21	M72	1387	324	98	108	C380 x 50	1219	79	102	946
22	3	67	12 3/4	4 1/4	4 1/4	C15 x 33.9	48	3 3/8	4	2856
22	M80x6	1702	324	108	108	C380 x 50	1219	86	102	1295

DIMENSIONS		TEMPERATURE	LOADS	WEIGHT
INCHES	FAHRENHEIT		POUNDS	POUNDS
MILLIMETERS	CELSIUS		NEWTONS	KILOGRAMS

SERIES 960 - TYPE A

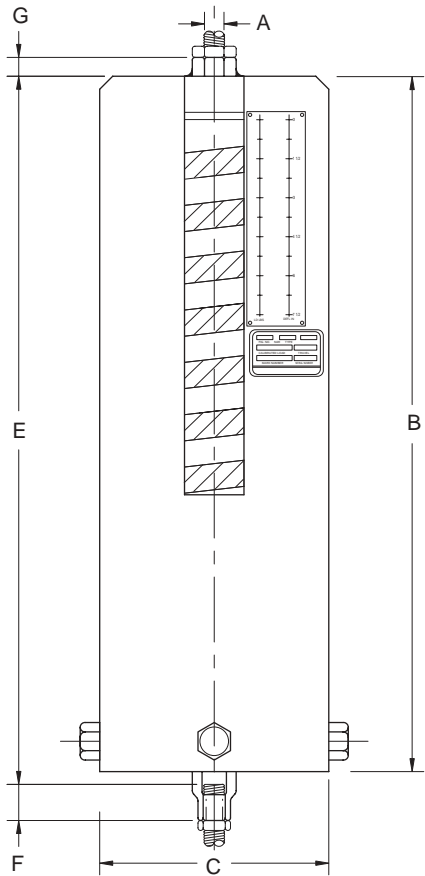

SIZE	ROD SIZE A	CASE LENGH B	CASE DIA. C	ROD T'OUT E	MIN. THD. ENGM'T F	ROD ENGM'T G	APPRX. WGT. EACH
0	1/2	20 1/2	4	20 3/8	7/8	7/8	22
0	M12	521	102	518	22	22	10
1	1/2	23 1/8	4	23	7/8	7/8	23
1	M12	587	102	584	22	22	10
2	1/2	25 3/8	4	25 1/4	7/8	7/8	26
2	M12	645	102	641	22	22	12
3	1/2	22 5/8	5 9/16	22 1/2	7/8	7/8	35
3	M12	575	141	572	22	22	16
4	1/2	25 1/2	5 9/16	25 3/8	7/8	7/8	43
4	M12	648	141	645	22	22	20
5	1/2	26	5 9/16	25 7/8	7/8	7/8	48
5	M12	660	141	657	22	22	22
6	5/8	26	6 5/8	25 3/4	1 1/8	1 1/8	63
6	M16	660	168	654	29	29	29
7	5/8	29	6 5/8	28 3/4	1 1/8	1 1/8	64
7	M16	737	168	730	29	29	29
8	5/8	30 1/2	6 5/8	30 1/4	1 1/8	1 1/8	75
8	M16	775	168	768	29	29	34
9	3/4	28 7/8	8 5/8	28 3/4	1 1/4	1 1/4	123
9	M20	733	219	730	32	32	56
10	3/4	34 1/2	8 5/8	34 3/8	1 1/4	1 1/4	139
10	M20	876	219	873	32	32	63
11	3/4	28	8 5/8	27 7/8	1 1/4	1 1/4	163
11	M20	711	219	708	32	32	74
12	1	30 1/2	8 5/8	30 3/8	1 5/8	1 5/8	185
12	M24	775	219	772	41	41	84
13	1	38 1/8	8 5/8	38	1 5/8	1 5/8	210
13	M24	968	219	965	41	41	95
14	1 1/4	38 3/4	8 5/8	38 1/2	1 3/4	1 5/8	224
14	M30	984	219	978	44	41	102
15	1 1/4	38 1/2	8 5/8	38 1/4	1 3/4	2	300
15	M30	978	219	972	44	51	136
16	1 1/2	46 3/8	8 5/8	46 1/4	2	2	403
16	M36	1178	219	1175	51	51	183
17	1 3/4	50 3/4	8 5/8	50 3/8	2 5/8	2 5/8	535
17	M42	1289	219	1280	67	67	243
18	2	51	12 3/4	50 7/8	2 7/8	2 7/8	783
18	M48	1295	324	1292	73	73	355
19	2 1/4	58 3/4	12 3/4	58 7/8	3 1/2	3 1/2	929
19	M56	1492	324	1495	89	89	421
20	2 1/2	69 3/4	12 3/4	69 5/8	3 7/8	3 7/8	1342
20	M64	1772	324	1768	98	98	609
21	2 3/4	77 1/2	12 3/4	77 3/8	4 1/4	4 1/4	1842
21	M72	1969	324	1965	108	108	836
22	3	94 7/8	12 3/4	95 1/8	4 1/4	4 1/4	2350
22	M80x6	2410	324	2416	108	108	1066

Ordering: Specify Figure Number (Travel Series), Type, Size, Hot Load, Cold Load, Movement and Direction of Movement (from the Cold/Installed position to the Hot/Operating position), and Hanger Identification Number (if any). Specify any other optional feature(s) as necessary.

For corrosion resistant units specify the Figure Number with the letter prefix "C", e.g. C960

For metric units specify the Figure Number with the letter prefix "M" e.g. M960 or MC960.

DIMENSIONS		TEMPERATURE	LOADS	WEIGHT
INCHES	FARENHEIT		POUNDS	POUNDS
MILLIMETERS	CELSIUS		NEWTONS	KILOGRAMS

FIGURE 960 TYPE B

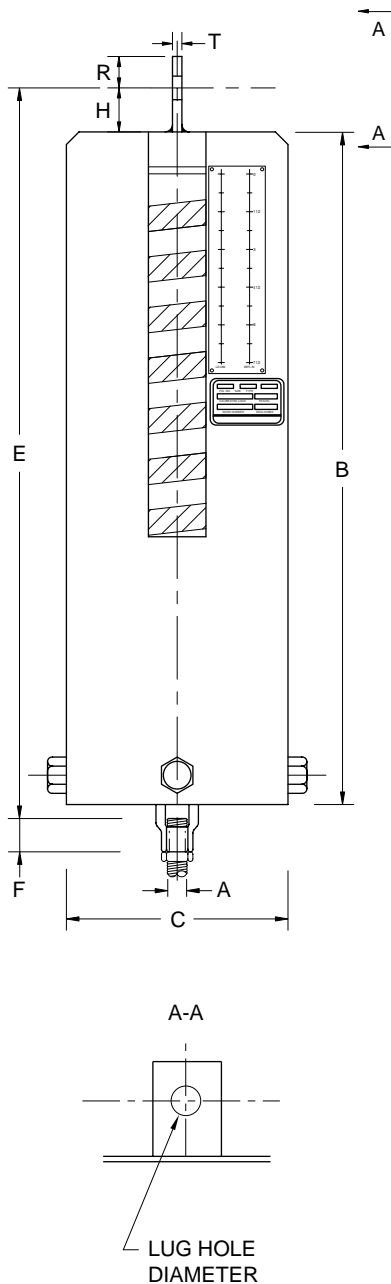

SIZE	ROD SIZE A	CASE LGTH. B	CASE DIA. C	ROD T'OUT E	MIN. THD. ENGMT F	HGT. OF PIN H	R	T	LUG HOLE DIA.	APPROX. WGT. EACH
0	1/2	20 1/2	4	2 1 7/8	7/8	1 1/2	1 1/4	1/4	1 1/16	22
0	M12	521	102	556	22	38	32	6	17	10
1	1/2	23 1/8	4	2 4 1/2	7/8	1 1/2	1 1/4	1/4	1 1/16	23
1	M12	587	102	622	22	38	32	6	17	10
2	1/2	25 3/8	4	2 6 3/4	7/8	1 1/2	1 1/4	1/4	1 1/16	26
2	M12	645	102	679	22	38	32	6	17	12
3	1/2	22 5/8	5 9/16	24	7/8	1 1/2	1 1/4	1/4	1 1/16	35
3	M12	575	141	610	22	38	32	6	17	16
4	1/2	25 1/2	5 9/16	26 7/8	7/8	1 1/2	1 1/4	1/4	1 1/16	43
4	M12	648	141	683	22	38	32	6	17	20
5	1/2	26	5 9/16	27 3/8	7/8	1 1/2	1 1/4	1/4	1 1/16	48
5	M12	660	141	695	22	38	32	6	17	22
6	5/8	26	6 3/8	27 1/4	1 1/8	1 1/2	1 1/4	1/4	1 3/16	64
6	M16	660	168	692	29	38	32	6	21	29
7	5/8	29	6 3/8	30 1/4	1 1/8	1 1/2	1 1/4	1/4	1 3/16	63
7	M16	737	168	768	29	38	32	6	21	29
8	5/8	30 1/2	6 3/8	31 3/4	1 1/8	1 1/2	1 1/4	1/4	1 3/16	75
8	M16	775	168	806	29	38	32	6	21	34
9	3/4	28 7/8	8 5/8	30 3/4	1 1/4	1 1/2	1 1/4	3/8	1 5/16	123
9	M20	733	219	768	32	38	32	10	24	56
10	3/4	34 1/2	8 5/8	35 3/8	1 1/4	1 1/2	1 1/4	3/8	1 5/16	139
10	M20	876	219	911	32	38	32	10	24	63
11	3/4	28	8 5/8	29 3/8	1 1/4	1 1/2	1 1/4	3/8	1 5/16	163
11	M20	711	219	746	32	38	32	10	24	74
12	1	30 1/2	8 5/8	32 3/8	1 5/8	2	1 1/2	1/2	1 1/4	185
12	M24	775	219	822	41	51	38	13	32	84
13	1	38 1/8	8 5/8	40	1 5/8	2	1 1/2	1/2	1 1/4	210
13	M24	968	219	1016	41	51	38	13	32	95
14	1 1/4	38 3/4	8 5/8	41 1/2	1 3/4	3	2	1/2	1 1/2	224
14	M30	984	219	1054	44	76	51	13	38	102
15	1 1/4	38 1/2	8 5/8	41 1/4	1 3/4	3	2	5/8	1 1/2	300
15	M30	978	219	1048	44	76	51	16	38	136
16	1 1/2	46 3/8	8 5/8	49 1/4	2	3	2 1/2	3/4	1 3/4	403
16	M36	1178	219	1251	51	76	64	19	44	183
17	1 3/4	50 3/4	8 5/8	53 3/8	2 5/8	3	2 1/2	3/4	2	535
17	M42	1289	219	1356	67	76	64	19	51	243
18	2	51	12 3/4	54 7/8	2 7/8	4	3	3/4	2 3/8	783
18	M48	1295	324	1394	73	102	76	19	60	355
19	2 1/4	58 3/4	12 3/4	63 3/8	3 1/2	4 1/2	3	3/4	2 5/8	929
19	M56	1492	324	1610	89	114	76	19	67	421
20	2 1/2	69 3/4	12 3/4	74 1/8	3 7/8	4 1/2	4	1	2 7/8	1342
20	M64	1772	324	1883	98	114	102	25	73	609
21	2 3/4	77 1/2	12 3/4	81 7/8	4 1/4	4 1/2	4	1	3 1/8	1475
21	M72	1969	324	2080	108	114	102	25	79	669
22	3	94 7/8	12 3/4	100 1/8	4 1/4	5	4	1	3 3/8	2025
22	M80x6	2410	324	2543	108	127	102	25	86	919

Ordering: Specify Figure Number (Travel Series), Type, Size, Hot Load, Cold Load, Movement and Direction of Movement (from the Cold/Installed position to the Hot/Operating position), and Hanger Identification Number (if any). Specify any other optional feature(s) as necessary.

Pins for attachment to the structure are not included with the unit and must be ordered separately as a Figure 291, shown on page 8 of this catalog. For ordering specify Figure Number, pin diameter and finish.

For corrosion resistant units specify the Figure Number with the letter prefix "C", e.g. C910

For metric units specify the Figure Number with the letter prefix "M" e.g. M910 or MC910.

DIMENSIONS	TEMPERATURE	LOADS	WEIGHT
INCHES	FAHRENHEIT	POUNDS	POUNDS
MILLIMETERS	CELSIUS	NEWTONS	KILOGRAMS

SERIES 960 - TYPE C

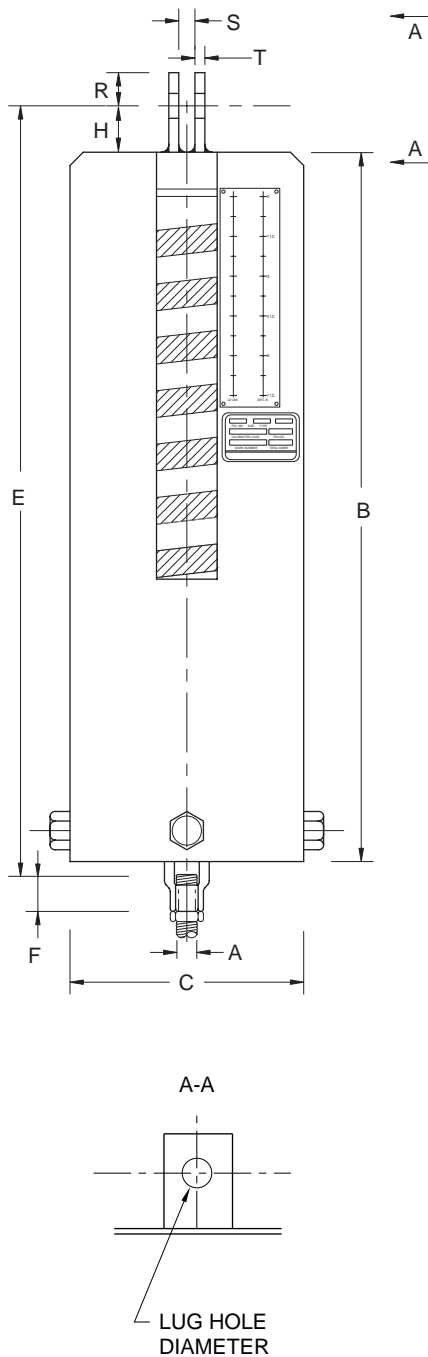

SIZE	ROD SIZE A	CASE LGTH. B	CASE DIA. C	ROD T'OUT E	MIN. THD. ENGM'T F	HGT. OF PIN H	R	S	T	LUG HOLE DIA.	APPROX. WGT EACH
0	1/2	20 1/2	4	21 7/8	7/8	1 1/2	1 1/4	7/8	1/4	1 1/16	22
0	M12	521	102	556	22	38	32	22	6	17	10
1	1/2	23 3/8	4	24 1/2	7/8	1 1/2	1 1/4	7/8	1/4	1 1/16	23
1	M12	587	102	622	22	38	32	22	6	17	10
2	1/2	25 3/8	4	26 3/4	7/8	1 1/2	1 1/4	7/8	1/4	1 1/16	26
2	M12	645	102	679	22	38	32	22	6	17	12
3	1/2	22 3/8	5 1/16	24	7/8	1 1/2	1 1/4	7/8	1/4	1 1/16	35
3	M12	575	141	610	22	38	32	22	6	17	16
4	1/2	25 1/2	5 1/16	26 7/8	7/8	1 1/2	1 1/4	7/8	1/4	1 1/16	43
4	M12	648	141	683	22	38	32	22	6	17	20
5	1/2	26	5 1/16	27 3/8	7/8	1 1/2	1 1/4	7/8	1/4	1 1/16	48
5	M12	660	141	695	22	38	32	22	6	17	22
6	3/8	26	6 3/8	27 1/4	1 1/8	1 1/2	1 1/4	1 1/16	1/4	1 3/16	64
6	M16	660	168	692	29	38	32	27	6	21	29
7	3/8	29	6 3/8	30 1/4	1 1/8	1 1/2	1 1/4	1 1/16	1/4	1 3/16	63
7	M16	737	168	768	29	38	32	27	6	21	29
8	3/8	30 1/2	6 3/8	31 3/4	1 1/8	1 1/2	1 1/4	1 1/16	1/4	1 3/16	75
8	M16	775	168	806	29	38	32	27	6	21	34
9	3/4	28 7/8	8 3/8	30 1/4	1 1/4	1 1/2	1 1/4	1 1/4	3/8	1 5/16	123
9	M20	733	219	768	32	38	32	32	10	24	56
10	3/4	34 1/2	8 3/8	35 7/8	1 1/4	1 1/2	1 1/4	1 1/4	3/8	1 5/16	139
10	M20	876	219	911	32	38	32	32	10	24	63
11	3/4	28	8 3/8	29 3/8	1 1/4	1 1/2	1 1/4	1 1/4	3/8	1 5/16	163
11	M20	711	219	746	32	38	32	32	10	24	74
12	1	30 1/2	8 3/8	32 3/8	1 5/8	2	1 1/2	1 1/4	1/2	1 1/4	185
12	M24	775	219	822	41	51	38	32	13	32	84
13	1	38 1/8	8 3/8	40	1 5/8	2	1 1/2	1 1/4	1/2	1 1/4	210
13	M24	968	219	1016	41	51	38	32	13	32	95
14	1 1/4	38 3/4	8 3/8	41 1/2	1 3/4	3	2	2	1/2	1 1/2	224
14	M30	984	219	1054	44	76	51	51	13	38	102
15	1 1/4	38 1/2	8 3/8	41 1/4	1 3/4	3	2	2	3/8	1 1/2	300
15	M30	978	219	1048	44	76	51	51	16	38	136
16	1 1/2	46 3/8	8 3/8	49 1/4	2	3	2 1/2	2 3/8	3/4	1 3/4	403
16	M36	1178	219	1251	51	76	64	60	19	44	183
17	1 3/4	50 3/4	8 3/8	53 3/8	2 3/8	3	2 1/2	2 3/8	3/4	2	535
17	M42	1289	219	1356	67	76	64	60	19	51	243
18	2	51	12 3/4	54 7/8	2 7/8	4	3	2 3/8	3/4	2 3/8	783
18	M48	1295	324	1394	73	102	76	60	19	60	355
19	2 1/4	58 3/4	12 3/4	63 3/8	3 1/2	4 1/2	3	2 3/8	3/4	2 5/8	929
19	M56	1492	324	1610	89	114	76	60	19	67	421
20	2 1/2	69 3/4	12 3/4	74 1/8	3 7/8	4 1/2	4	3 3/8	1	2 7/8	1342
20	M64	1772	324	1883	98	114	102	86	25	73	609
21	2 3/4	77 1/2	12 3/4	81 7/8	4 1/4	4 1/2	4	3 3/8	1	3 3/8	1475
21	M72	1969	324	2080	108	114	102	86	25	79	669
22	3	94 7/8	12 3/4	100 1/8	4 1/4	5	4	3 7/8	1	3 3/8	2025
22	M80x6	2410	324	2543	108	127	102	98	25	86	919

Ordering: Specify Figure Number (Travel Series), Type, Size, Hot Load, Cold Load, Movement and Direction of Movement (from the Cold/Installed position to the Hot/Operating position), and Hanger Identification Number (if any). Specify any other optional feature(s) as necessary.

Pins for attachment to the structure are not included with the unit and must be ordered separately as a Figure 291, shown on page 8 of this catalog. For ordering specify Figure Number, pin diameter and finish.

For corrosion resistant units specify the Figure Number with the letter prefix "C", e.g. C910

For metric units specify the Figure Number with the letter prefix "M" e.g. M910 or MC910.

DIMENSIONS		TEMPERATURE	LOADS		WEIGHT
INCHES	FAHRENHEIT		POUNDS	POUNDS	
MILLIMETERS	CELSIUS		NEWTONS	KILOGRAMS	

VARIABLE SPRING SUPPORTS

SERIES 960 TYPE D

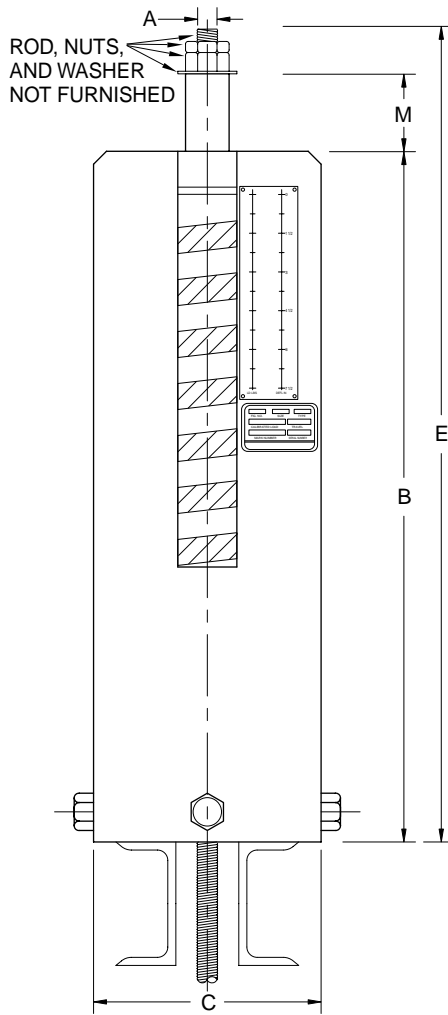

HANGER SIZE	ROD SIZE A	CASE LENGTH B	CASE DIA. C	ROD TAKEOUT E	HGT. OF SPACER M	APPROX. WEIGHT EACH
0	1/2	20 1/2	4	29 3/4	8 1/2	21
0	M12	521	102	756	216	9.5
1	1/2	23 3/8	4	32 3/8	8 1/2	22
1	M12	587	102	822	216	10
2	1/2	25 3/8	4	34 5/8	8 1/2	25
2	M12	645	102	879	216	11
3	1/2	22 5/8	5 9/16	31 7/8	8 1/2	34
3	M12	575	141	810	216	15
4	1/2	25 1/2	5 9/16	34 3/4	8 1/2	42
4	M12	648	141	883	216	19
5	1/2	26	5 9/16	35 1/4	8 1/2	46
5	M12	660	141	895	216	21
6	5/8	26	6 5/8	35 1/2	8 1/2	60
6	M16	660	168	902	216	27
7	5/8	29	6 5/8	38 1/2	8 1/2	62
7	M16	737	168	978	216	28
8	5/8	30 1/2	6 5/8	40	8 1/2	73
8	M16	775	168	1016	216	33
9	3/4	28 7/8	8 5/8	38 5/8	8 5/8	119
9	M20	733	219	981	219	54
10	3/4	34 1/2	8 5/8	44 1/4	8 5/8	135
10	M20	876	219	1124	219	61
11	3/4	28	8 5/8	37 3/4	8 5/8	157
11	M20	711	219	959	219	71
12	1	30 1/2	8 5/8	41	9	178
12	M24	775	219	1041	229	81
13	1	30 3/8	8 5/8	40 1/4	9	198
13	M24	765	219	1022	229	90
14	1 1/4	38 3/4	8 5/8	49 7/8	9 1/4	212
14	M30	984	219	1267	235	96
15	1 1/4	38 1/2	8 5/8	49 1/2	9 1/8	285
15	M30	978	219	1257	232	129
16	1 1/2	46 3/8	8 5/8	58 1/4	9 5/8	375
16	M36	1178	219	1480	244	170
17	1 3/4	50 3/4	8 5/8	62 1/8	9 3/4	491
17	M42	1289	219	1578	248	223
18	2	51	12 3/4	64	10	732
18	M48	1295	324	1626	254	332
19	2 1/4	58 3/4	12 3/4	72 3/8	10 1/4	863
19	M56	1492	324	1838	260	391
20	2 1/2	69 3/4	12 3/4	84	10 1/2	1225
20	M64	1772	324	2134	267	556
21	2 3/4	77 1/2	12 3/4	92 3/8	10 3/4	1662
21	M72	1969	324	2346	273	754
22	3	94 7/8	12 3/4	110 3/8	11	2232
22	M80x6	2410	324	2805	279	1012

Ordering: Specify Figure Number (Travel Series), Type, Size, Hot Load, Cold Load, Movement and Direction of Movement (from the Cold/Installed position to the Hot/Operating position), and Hanger Identification Number (if any). Specify any other optional feature(s) as necessary.

For corrosion resistant units specify the Figure Number with the letter prefix "C", e.g. C960

For metric units specify the Figure Number with the letter prefix "M" e.g. M960 or MC960.

DIMENSIONS	TEMPERATURE	LOADS	WEIGHT
INCHES	FAHRENHEIT	POUNDS	POUNDS
MILLIMETERS	CELSIUS	NEWTONS	KILOGRAMS

SERIES 960 TYPE E

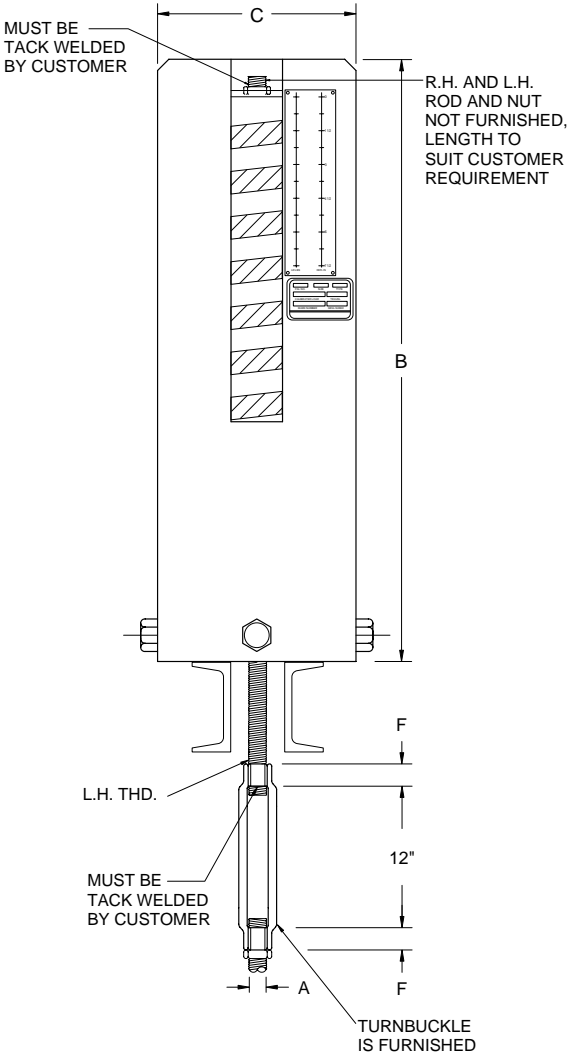

HANGER SIZE	ROD SIZE A	CASE LENGTH B	CASE DIAMETER C	MIN. THD. ENGMT F	APPROX. WEIGHT EACH
0	1/2	20 1/2	4	7/8	21
0	M12	521	102	22	9.5
1	1/2	23 1/8	4	7/8	22
1	M12	587	102	22	10
2	1/2	25 3/8	4	7/8	25
2	M12	645	102	22	11
3	1/2	22 5/8	5 1/16	7/8	34
3	M12	575	141	22	15
4	1/2	25 1/2	5 1/16	7/8	42
4	M12	648	141	22	19
5	1/2	26	5 1/16	7/8	46
5	M12	660	141	22	21
6	5/8	26	6 3/8	1 1/8	60
6	M16	660	168	29	27
7	5/8	29	6 3/8	1 1/8	62
7	M16	737	168	29	28
8	5/8	30 1/2	6 3/8	1 1/8	73
8	M16	775	168	29	33
9	3/4	28 7/8	8 5/8	1 1/4	119
9	M20	733	219	32	54
10	3/4	34 1/2	8 5/8	1 1/4	135
10	M20	876	219	32	61
11	3/4	28	8 5/8	1 1/4	157
11	M20	711	219	32	71
12	1	30 1/2	8 5/8	1 5/8	178
12	M24	775	219	41	81
13	1	38 1/8	8 5/8	1 5/8	198
13	M24	968	219	41	90
14	1 1/4	38 3/4	8 5/8	1 3/4	212
14	M30	984	219	44	96
15	1 1/4	38 1/2	8 5/8	1 3/4	285
15	M30	978	219	44	129
16	1 1/2	46 3/8	8 5/8	2	375
16	M36	1178	219	51	170
17	1 3/4	50 3/4	8 5/8	2 5/8	491
17	M42	1289	219	67	223
18	2	51	12 3/4	2 7/8	732
18	M48	1295	324	73	332
19	2 1/4	58 3/4	12 3/4	3 1/2	863
19	M56	1492	324	89	391
20	2 1/2	69 3/4	12 3/4	3 7/8	1225
20	M64	1772	324	98	556
21	2 3/4	77 1/2	12 3/4	4 1/4	1662
21	M72	1969	324	108	754
22	3	94 7/8	12 3/4	4 1/4	2232
22	M80X6	2410	324	108	1012

Ordering: Specify Figure Number (Travel Series), Type, Size, Hot Load, Cold Load, Movement and Direction of Movement (from the Cold/Installed position to the Hot/Operating position), and Hanger Identification Number (if any). Specify any other optional feature(s) as necessary.

For corrosion resistant units specify the Figure Number with the letter prefix "C", e.g. C960

For metric units specify the Figure Number with the letter prefix "M" e.g. M960 or MC960.

DIMENSIONS		TEMPERATURE	LOADS	WEIGHT
INCHES	FAHRENHEIT	POUNDS	POUNDS	
MILLIMETERS	CELSIUS	NEWTONS	KILOGRAMS	

VARIABLE SPRING SUPPORTS

SERIES 960 - TYPE F

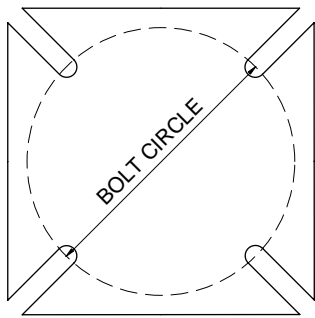
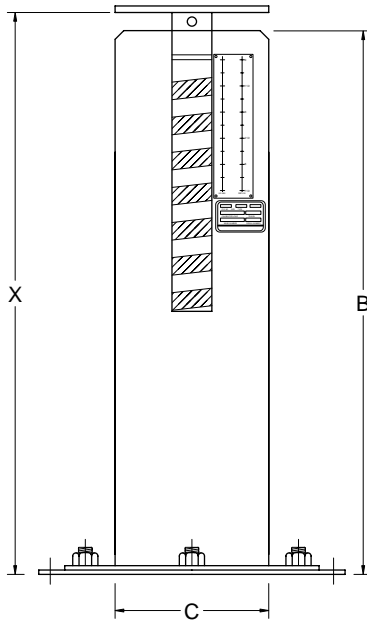

SIZE	CASE LNTH. B	CASE DIA. C	BOTTOM FLANGE BOLT DIA.	BOTTOM FLANGE	BOLT CIRCLE		OVERALL LNTH. X **		LOAD FLANGE DIA.	LOAD FLANGE THICK.	APPROX. WGT. EACH
					MIN.	MAX.	MIN.	MAX.			
0	18¾	4	⅝	¼ x 7½ x 7½	7	9¾	20¼	22¼	3⅞	¼	31
0	476	102	16	6 x 191 x 191	178	248	514	565	98	6	14
1	21⅜	4	⅝	¼ x 7½ x 7½	7	9¾	22⅞	24⅞	3⅞	¼	31
1	543	102	16	6 x 191 x 191	178	248	581	632	98	6	14
2	23⅝	4	⅝	¼ x 7½ x 7½	7	9¾	25⅞	27⅞	3⅞	¼	35
2	600	102	16	6 x 191 x 191	178	248	638	689	98	6	16
3	21	5⅞	¾	¼ x 7½ x 7½	7¾	9¾	22½	24½	5⅞	¼	51
3	533	141	19	6 x 191 x 191	197	248	572	622	137	6	23
4	22⅞	5⅞	¾	¼ x 7½ x 7½	7¾	9¾	24⅜	26⅜	5⅞	¼	59
4	581	141	19	6 x 191 x 191	197	248	619	670	137	6	27
5	24¾	5⅞	¾	¼ x 7½ x 7½	7¾	9¾	26⅜	28⅜	5⅞	¼	64
5	629	141	19	6 x 191 x 191	197	248	670	721	137	6	29
6	24½	6⅞	¾	⅜ x 9 x 9	9¼	10½	26¼	28¼	6⅞	¼	92
6	622	168	19	10 x 229 x 229	235	267	667	718	162	6	42
7	25⅜	6⅞	¾	⅜ x 9 x 9	9¼	10½	29⅞	31⅞	6⅞	¼	90
7	645	168	19	10 x 229 x 229	235	267	740	791	162	6	41
8	28¾	6⅞	¾	⅜ x 9 x 9	9¼	10½	30½	32½	6⅞	¼	104
8	730	168	19	10 x 229 x 229	235	267	775	826	162	6	47
9	26⅞	8⅞	¾	½ x 13¼ x 13¼	10⅞	16¼	28⅞	30⅞	8⅞	½	171
9	683	219	19	13 x 337 x 337	268	413	733	784	213	13	78
10	32½	8⅞	¾	½ x 13¼ x 13¼	10⅞	16¼	34½	36½	8⅞	½	188
10	826	219	19	13 x 337 x 337	268	413	876	927	213	13	85
11	25⅞	8⅞	¾	½ x 13¼ x 13¼	10⅞	16¼	27⅞	29⅞	8⅞	½	207
11	657	219	19	13 x 337 x 337	268	413	708	759	213	13	94
12	27½	8⅞	¾	½ x 13¼ x 13¼	10⅞	16¼	28½	30½	8⅞	½	229
12	699	219	19	13 x 337 x 337	268	413	724	775	213	13	104
13	35½	8⅞	¾	½ x 13¼ x 13¼	10⅞	16¼	37½	39½	8⅞	½	246
13	902	219	19	13 x 337 x 337	268	413	953	1003	213	13	112
14	35⅞	8⅞	¾	½ x 13¼ x 13¼	10⅞	16¼	37⅞	39⅞	8⅞	½	261
14	911	219	19	13 x 337 x 337	268	413	962	1013	213	13	118
15	35⅞	8⅞	¾	½ x 13¼ x 13¼	10⅞	16¼	37⅞	39⅞	8⅞	½	335
15	911	219	19	13 x 337 x 337	268	413	959	1013	213	13	152
16	42¾	8⅞	¾	½ x 13¼ x 13¼	10⅞	16¼	44¾	46¾	8⅞	½	428
16	1086	219	19	13 x 337 x 337	268	413	1137	1187	213	13	194
17	49	8⅞	¾	½ x 13¼ x 13¼	10⅞	16¼	51	53	8⅞	½	542
17	1245	219	19	13 x 337 x 337	268	413	1295	1346	213	13	246
18	46⅞	12¾	¾	⅝ x 17¼ x 17¼	15¾	21	49	51	12½	½	805
18	1191	324	19	16 x 438 x 438	400	533	1245	1295	318	13	365
19	53⅞	12¾	¾	⅝ x 17¼ x 17¼	15¾	21	55¾	57¾	12½	½	826
19	1362	324	19	16 x 438 x 438	400	533	1416	1467	318	13	375
20	63⅞	12¾	¾	⅝ x 17¼ x 17¼	15¾	21	66¼	68¼	12½	½	1178
20	1610	324	19	16 x 438 x 438	400	533	1683	1734	318	13	534
21	70¼	12¾	¾	⅝ x 17¼ x 17¼	15¾	21	73⅞	75⅞	12½	½	1425
21	1784	324	19	16 x 438 x 438	400	533	1857	1908	318	13	646
22	88½	12¾	¾	⅝ x 17¼ x 17¼	15¾	21	91⅞	93⅞	12½	½	1700
22	2248	324	19	16 x 438 x 438	400	533	2321	2372	318	13	771

** The Installed Height should be the mid-point between the Maximum and Minimum Overall Height "X", plus the thickness of the Load Flange, and plus any DOWN piping movement when applicable.

Ordering: Specify Figure Number (Travel Series), Type, Size, Hot Load, Cold Load, Movement and Direction of Movement (from the Cold/Installed position to the Hot/Operating position), Dimension X (Installed Height) and Hanger Identification Number (if any). Specify any other optional feature(s) as necessary.

For corrosion resistant units specify the Figure Number with the letter prefix "C", e.g. C960

For metric units specify the Figure Number with the letter prefix "M" e.g. M960 or MC960.

DIMENSIONS		TEMPERATURE	LOADS	WEIGHT
INCHES	FAHRENHEIT		POUNDS	POUNDS
MILLIMETERS	CELSIUS		NEWTONS	KILOGRAMS

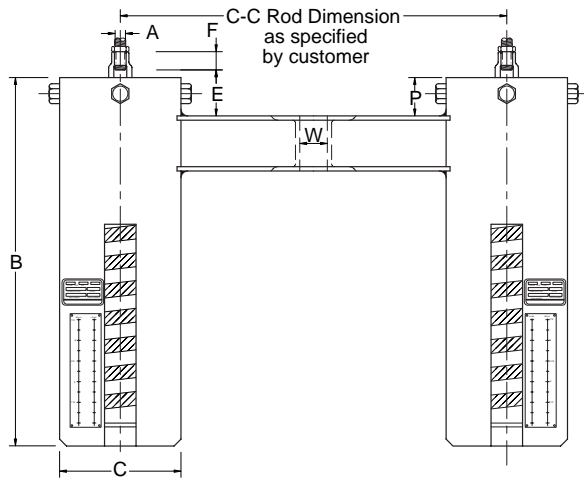

Ordering: Specify Figure Number (Travel Series), Type, Size, Total Load, Hot Load per spring, Cold Load per spring, Movement and Direction of Movement (from the Cold/Installed position to the Hot/Operating position), Center to Center of Rods dimension and Hanger Identification Number (if any). Specify any other optional feature(s) as necessary.

For corrosion resistant units specify the Figure Number with the letter prefix "C", e.g. C960

For metric units specify the Figure Number with the letter prefix "M" e.g. M960 or MC960.

FIGURE 960 TYPE G

HANGER SIZE	ROD SIZE A	CASE LENGTH B	CASE DIAMETER C	ROD TAKEOUT E	MIN. THD. ENGM'T F	CHANNEL SIZE	MAX. C - C	CHANNEL SPACING W	P	APPROX. WEIGHT EACH
0	1/2	20 1/2	4	1 3/8	7/8	C3 x 4.1	24	5/8	1 1/2	55
0	M12	521	102	35	22	C75 x 6	610	16	38	25
1	1/2	23 3/8	4	1 3/8	7/8	C3 x 4.1	24	5/8	1 1/2	57
1	M12	587	102	35	22	C75 x 6	610	16	38	26
2	1/2	25 3/8	4	1 3/8	7/8	C3 x 4.1	24	5/8	1 1/2	64
2	M12	645	102	35	22	C75 x 6	610	16	38	29
3	1/2	22 5/8	5 1/16	1 7/8	7/8	C3 x 4.1	30	3/4	2	81
3	M12	575	141	48	22	C75 x 6	762	19	51	37
4	1/2	25 1/2	5 1/16	1 7/8	7/8	C3 x 4.1	30	3/4	2	99
4	M12	648	141	48	22	C75 x 6	762	19	51	45
5	1/2	26	5 1/16	1 7/8	7/8	C3 x 4.1	30	3/4	2	106
5	M12	660	141	48	22	C75 x 6	762	19	51	48
6	5/8	26	6 5/8	2 7/8	1 1/8	C3 x 4.1	36	1	2	139
6	M16	660	168	73	29	C75 x 6	914	25	51	63
7	5/8	29	6 5/8	2 7/8	1 1/8	C3 x 4.1	36	1	2	135
7	M16	737	168	73	29	C75 x 6	914	25	51	61
8	5/8	30 1/2	6 5/8	2 7/8	1 1/8	C3 x 4.1	36	1	2	162
8	M16	775	168	73	29	C75 x 6	914	25	51	73
9	3/4	28 7/8	8 5/8	2 7/8	1 1/4	C4 x 5.4	36	1 1/4	3	255
9	M20	733	219	73	32	C100 x 8	914	32	76	116
10	3/4	34 1/2	8 5/8	2 7/8	1 1/4	C4 x 5.4	36	1 1/4	3	287
10	M20	876	219	73	32	C100 x 8	914	32	76	130
11	3/4	28	8 5/8	2 7/8	1 1/4	C4 x 5.4	36	1 1/4	3	336
11	M20	711	219	73	32	C100 x 8	914	32	76	152
12	1	30 1/2	8 5/8	3 3/8	1 5/8	C5 x 6.7	36	1 1/2	4	384
12	M24	775	219	98	41	C130 x 10	914	38	102	174
13	1	38 1/8	8 5/8	3 3/8	1 5/8	C5 x 6.7	36	1 1/2	4	432
13	M24	968	219	98	41	C130 x 10	914	38	102	196
14	1 1/4	38 3/4	8 5/8	3 3/8	1 3/4	C5 x 6.7	36	1 1/2	4	460
14	M30	984	219	98	44	C130 x 10	914	38	102	209
15	1 1/4	38 1/2	8 5/8	3 3/8	1 3/4	C8 x 11.5	36	2 1/8	4	621
15	M30	978	219	98	44	C200 x 17	914	54	102	282
16	1 1/2	46 3/8	8 5/8	3 3/8	2	C8 x 11.5	36	2 1/8	4	821
16	M36	1178	219	98	51	C200 x 17	914	54	102	372
17	1 3/4	50 3/4	8 5/8	3 3/8	2 5/8	C8 x 11.5	36	2 1/8	4	1085
17	M42	1289	219	98	67	C200 x 17	914	54	102	492
18	2	51	12 3/4	3 3/8	2 7/8	C12 x 20.7	42	2 3/8	4	1582
18	M48	1295	324	98	73	C130 x 31	1067	60	102	718
19	2 1/4	58 3/4	12 3/4	3 1/2	3 1/2	C12 x 20.7	42	2 5/8	4	1870
19	M56	1492	324	89	89	C130 x 31	1067	67	102	848
20	2 1/2	69 3/4	12 3/4	3 3/8	3 3/8	C12 x 20.7	40	2 7/8	4	2668
20	M64	1772	324	98	98	C130 x 31	1016	73	102	1210
21	2 3/4	77 1/2	12 3/4	4 1/4	4 1/4	C15 x 33.9	48	3 1/8	4	3560
21	M72	1969	324	108	108	C380 x 50	1219	79	102	1615
22	3	94 7/8	12 3/4	4 1/4	4 1/4	C15 x 33.9	48	3 3/8	4	4600
22	M80x6	2410	324	108	108	C380 x 50	1219	86	102	2087

DIMENSIONS		TEMPERATURE	LOADS	WEIGHT
INCHES	FAHRENHEIT	POUNDS	POUNDS	POUNDS
MILLIMETERS	CELSIUS	NEWTONS	KILOGRAMS	KILOGRAMS

VARIABLE SPRING SUPPORTS

SERIES 980 - TYPE A

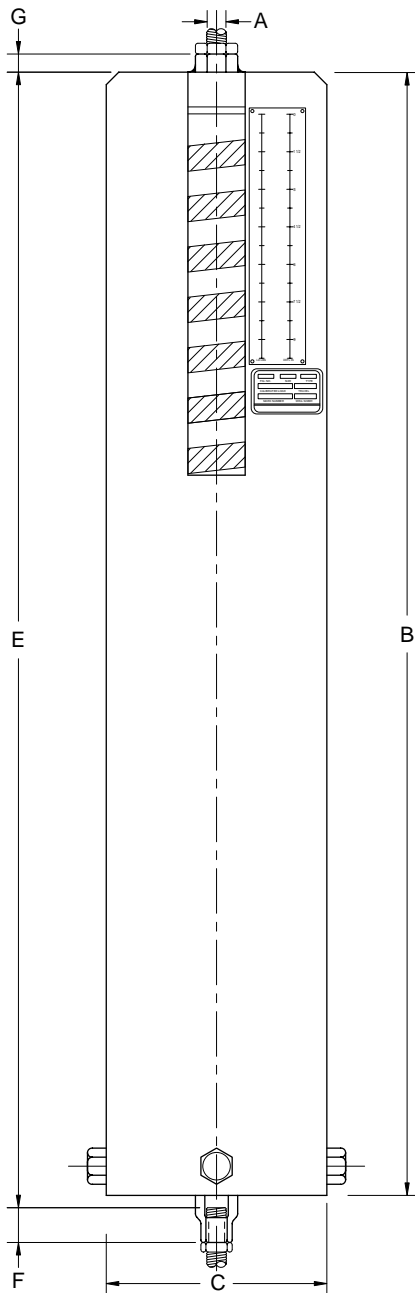

SIZE	ROD SIZE A	CASE LGTH B	CASE DIA. C	ROD T'OUT E	MIN. THD. ENGM'T F	ROD ENGM'T G	APPROX. WGT EACH
0	1/2	27	4	26 7/8	7/8	7/8	32
0	M12	686	102	683	22	22	15
1	1/2	29 3/8	4	29 1/4	7/8	7/8	34
1	M12	746	102	743	22	22	15
2	1/2	30 3/8	4	30 1/4	7/8	7/8	38
2	M12	772	102	768	22	22	17
3	1/2	29 1/2	5 9/16	29 3/8	7/8	7/8	52
3	M12	749	141	746	22	22	24
4	1/2	32	5 9/16	31 7/8	7/8	7/8	62
4	M12	813	141	810	22	22	28
5	1/2	34 3/4	5 9/16	34 5/8	7/8	7/8	68
5	M12	883	141	879	22	22	31
6	5/8	34	6 3/8	33 3/4	1 1/8	1 1/8	90
6	M16	864	168	857	29	29	41
7	5/8	37 7/8	6 3/8	37 3/4	1 1/8	1 1/8	88
7	M16	962	168	959	29	29	40
8	5/8	39 3/4	6 3/8	39 1/2	1 1/8	1 1/8	106
8	M16	1010	168	1003	29	29	48
9	3/4	39 7/8	8 3/8	39 3/4	1 1/4	1 1/4	170
9	M20	1013	219	1010	32	32	77
10	3/4	44 7/8	8 3/8	44 3/4	1 1/4	1 1/4	187
10	M20	1140	219	1137	32	32	85
11	3/4	36 1/8	8 3/8	36	1 1/4	1 1/4	219
11	M20	918	219	914	32	32	99
12	1	39 1/4	8 3/8	39 1/8	1 5/8	1 5/8	253
12	M24	997	219	994	41	41	115
13	1	49 1/2	8 3/8	49 3/8	1 5/8	1 5/8	287
13	M24	1257	219	1254	41	41	130
14	1 1/4	50 1/4	8 3/8	50	1 3/4	1 3/4	303
14	M30	1276	219	1270	44	44	137
15	1 1/4	49 3/4	8 3/8	49 1/2	1 3/4	1 3/4	420
15	M30	1264	219	1257	44	44	191
16	1 1/2	60	8 3/8	59 7/8	2	2	550
16	M36	1524	219	1521	51	51	249
17	1 3/4	68 1/2	8 3/8	68 1/8	2 5/8	2 5/8	733
17	M42	1740	219	1730	67	67	332
18	2	66	12 3/4	65 7/8	2 7/8	2 7/8	1122
18	M48	1676	324	1673	73	73	509
19	2 1/4	75 3/4	12 3/4	75 5/8	3 1/2	3 1/2	1310
19	M56	1924	324	1921	89	89	594
20	2 1/2	90	12 3/4	89 7/8	3 7/8	3 7/8	1872
20	M64	2286	324	2283	98	98	849
21	2 3/4	100	12 3/4	99 7/8	4 1/4	4 1/4	2052
21	M72	2540	324	2537	108	108	931
22	3	124 1/2	12 3/4	124 3/8	4 1/4	4 1/4	2831
22	M80x6	3162	324	3159	108	108	1284

Ordering: Specify Figure Number (Travel Series), Type, Size, Hot Load, Cold Load, Movement and Direction of Movement (from the Cold/Installed position to the Hot/Operating position), and Hanger Identification Number (if any). Specify any other optional feature(s) as necessary.

For corrosion resistant units specify the Figure Number with the letter prefix "C", e.g. C980

For metric units specify the Figure Number with the letter prefix "M" e.g. M980 or MC980.

DIMENSIONS		TEMPERATURE	LOADS	WEIGHT
INCHES	FAHRENHEIT		POUNDS	POUNDS
MILLIMETERS	CELSIUS		NEWTONS	KILOGRAMS

FIGURE 980 TYPE B

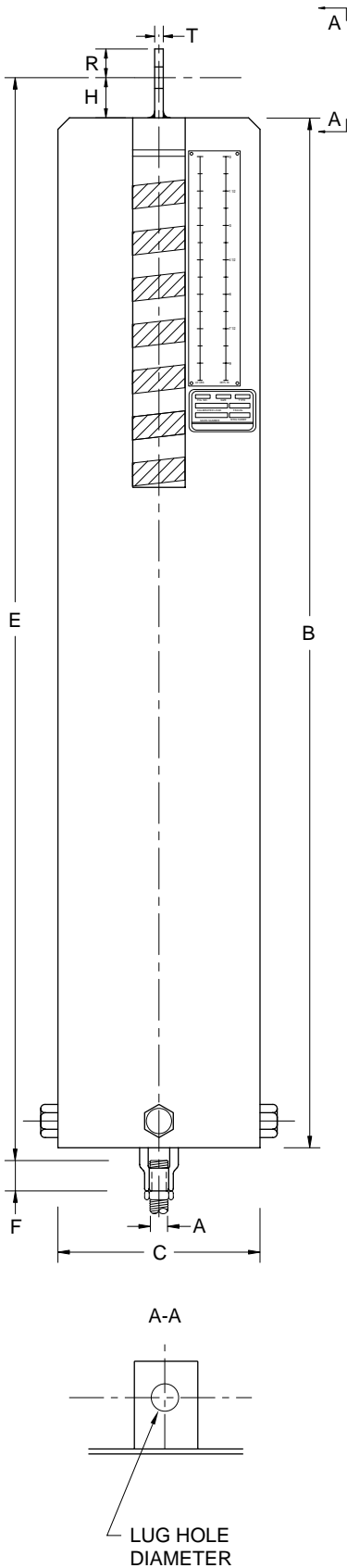

SIZE	ROD SIZE A	CASE LGTH. B	CASE DIA. C	ROD T'OUT E	MIN. THD. ENGM'T F	HGT. OF PIN H	R	T	LUG HOLE DIA.	APPROX. WGT. EACH
0	1/2	27	4	28 3/8	7/8	1 1/2	1/4	1/4	1 1/16	32
0	M12	686	102	721	22	38	32	6	17	15
1	1/2	29 3/8	4	30 3/4	7/8	1 1/2	1/4	1/4	1 1/16	34
1	M12	746	102	781	22	38	32	6	17	15
2	1/2	30 3/8	4	31 3/4	7/8	1 1/2	1/4	1/4	1 1/16	38
2	M12	772	102	806	22	38	32	6	17	17
3	1/2	29 1/2	5 9/16	30 7/8	7/8	1 1/2	1/4	1/4	1 1/16	52
3	M12	749	141	784	22	38	32	6	17	24
4	1/2	32	5 9/16	33 3/8	7/8	1 1/2	1/4	1/4	1 1/16	62
4	M12	813	141	848	22	38	32	6	17	28
5	1/2	34 3/4	5 9/16	36 1/8	7/8	1 1/2	1/4	1/4	1 1/16	68
5	M12	883	141	918	22	38	32	6	17	31
6	5/8	34	6 5/8	35 1/4	1 1/8	1 1/2	1/4	1/4	1 3/16	90
6	M16	864	168	895	29	38	32	6	21	41
7	5/8	37 7/8	6 5/8	38 1/4	1 1/8	1 1/2	1/4	1/4	1 3/16	88
7	M16	962	168	972	29	38	32	6	21	40
8	5/8	39 3/4	6 5/8	41	1 1/8	1 1/2	1/4	1/4	1 3/16	106
8	M16	1010	168	1041	29	38	32	6	21	48
9	3/4	39 7/8	8 5/8	41 1/4	1 1/4	1 1/2	1/4	3/8	1 5/16	170
9	M20	1013	219	1048	32	38	32	10	24	77
10	3/4	44 7/8	8 5/8	46 1/4	1 1/4	1 1/2	1/4	3/8	1 5/16	187
10	M20	1140	219	1175	32	38	32	10	24	85
11	3/4	36 1/8	8 5/8	37 1/2	1 1/4	1 1/2	1/4	3/8	1 5/16	219
11	M20	918	219	953	32	38	32	10	24	99
12	1	39 1/4	8 5/8	41 1/8	1 5/8	2	1 1/2	1/2	1 1/4	253
12	M24	997	219	1045	41	51	38	13	32	115
13	1	49 1/2	8 5/8	51 3/8	1 5/8	2	1 1/2	1/2	1 1/4	287
13	M24	1257	219	1305	41	51	38	13	32	130
14	1 1/4	50 1/4	8 5/8	53	1 3/4	3	2	1/2	1 1/2	303
14	M30	1276	219	1346	44	76	51	13	38	137
15	1 1/4	49 3/4	8 5/8	52 1/2	1 3/4	3	2	5/8	1 1/2	420
15	M30	1264	219	1334	44	76	51	16	38	191
16	1 1/2	60	8 5/8	62 7/8	2	3	2 1/2	3/4	1 3/4	550
16	M36	1524	219	1597	51	76	64	19	44	249
17	1 3/4	68 1/2	8 5/8	71 1/8	2 5/8	3	2 1/2	3/4	2	733
17	M42	1740	219	1807	67	76	64	19	51	332
18	2	66	12 3/4	69 7/8	2 7/8	4	3	3/4	2 3/8	1122
18	M48	1676	324	1775	73	102	76	19	60	509
19	2 1/4	75 3/4	12 3/4	80 1/8	3 1/2	4 1/2	3	3/4	2 5/8	1310
19	M56	1924	324	2035	89	114	76	19	67	594
20	2 1/2	90	12 3/4	94 3/8	3 7/8	4 1/2	4	1	2 7/8	1872
20	M64	2286	324	2397	98	114	102	25	73	849
21	2 3/4	100	12 3/4	104 3/8	4 1/4	4 1/2	4	1	3 1/8	2052
21	M72	2540	324	2651	108	114	102	25	79	931
22	3	124 1/2	12 3/4	129 3/8	4 1/4	5	4	1	3 3/8	2831
22	M80X6	3162	324	3286	108	127	102	25	86	1284

Ordering: Specify Figure Number (Travel Series), Type, Size, Hot Load, Cold Load, Movement and Direction of Movement (from the Cold/Installed position to the Hot/Operating position), and Hanger Identification Number (if any). Specify any other optional feature(s) as necessary.

Pins for attachment to the structure are not included with the unit and must be ordered separately as a Figure 291, shown on page 8 of this catalog. For ordering specify Figure Number, pin diameter and finish.

For corrosion resistant units specify the Figure Number with the letter prefix "C", e.g. C910

For metric units specify the Figure Number with the letter prefix "M" e.g. M910 or MC910.

DIMENSIONS		TEMPERATURE	LOADS	WEIGHT
INCHES	FAHRENHEIT	POUNDS	POUNDS	
MILLIMETERS	CELSIUS	NEWTONS	KILOGRAMS	

VARIABLE SPRING SUPPORTS

SERIES 980 - TYPE C

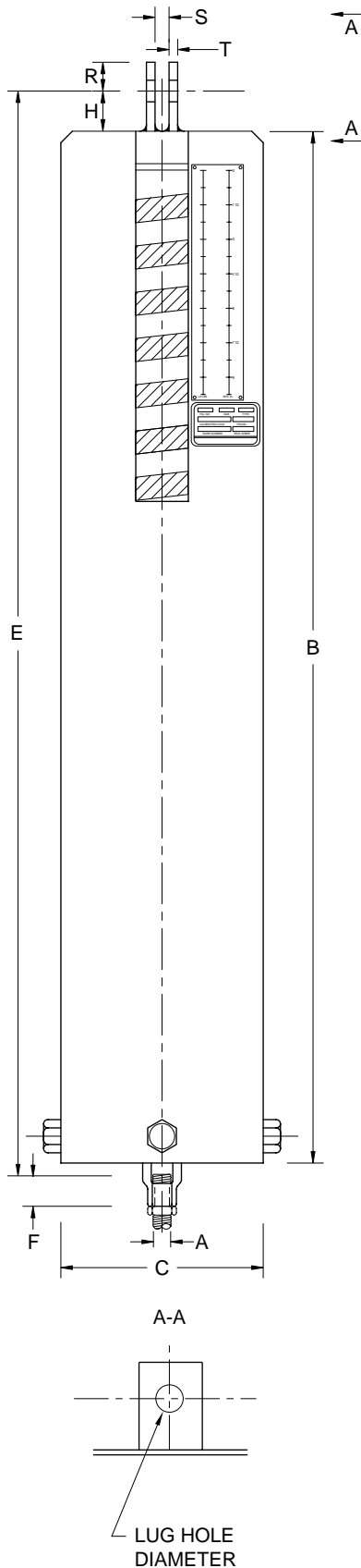

SIZE	ROD SIZE A	CASE LGTH. B	CASE DIA. C	ROD T'OUT E	MIN. THD. ENGM'T F	HGT. OF PIN H	R	S	T	LUG HOLE DIA.	APPROX. WGT EACH
0	1/2	27	4	28 3/8	7/8	1 1/2	1 1/4	1 1/4	1/4	1 1/16	32
0	M12	686	102	721	22	38	32	32	6	17	15
1	1/2	29 3/8	4	30 3/4	7/8	1 1/2	1 1/4	1 1/4	1/4	1 1/16	34
1	M12	746	102	781	22	38	32	32	6	17	15
2	1/2	30 3/8	4	31 3/4	7/8	1 1/2	1 1/4	1 1/4	1/4	1 1/16	38
2	M12	772	102	806	22	38	32	32	6	17	17
3	1/2	29 1/2	5 1/16	30 7/8	7/8	1 1/2	1 1/4	1 1/4	1/4	1 1/16	52
3	M12	749	141	784	22	38	32	32	6	17	24
4	1/2	32	5 1/16	33 3/8	7/8	1 1/2	1 1/4	1 1/4	1/4	1 1/16	62
4	M12	813	141	848	22	38	32	32	6	17	28
5	1/2	34 3/4	5 1/16	36 1/8	7/8	1 1/2	1 1/4	1 1/4	1/4	1 1/16	68
5	M12	883	141	918	22	38	32	32	6	17	31
6	5/8	34	6 3/8	35 1/4	1 1/8	1 1/2	1 1/4	1 1/4	1/4	1 3/16	90
6	M16	864	168	895	29	38	32	32	6	21	41
7	5/8	37 7/8	6 3/8	38 1/4	1 1/8	1 1/2	1 1/4	1 1/4	1/4	1 3/16	88
7	M16	962	168	972	29	38	32	32	6	21	40
8	5/8	39 3/4	6 3/8	41	1 1/8	1 1/2	1 1/4	1 1/4	1/4	1 3/16	106
8	M16	1010	168	1041	29	38	32	32	6	21	48
9	3/4	39 7/8	8 3/8	41 1/4	1 1/4	1 1/2	1 1/4	1 1/4	3/8	1 5/16	170
9	M20	1013	219	1048	32	38	32	32	10	24	77
10	3/4	44 7/8	8 3/8	46 1/4	1 1/4	1 1/2	1 1/4	1 1/4	3/8	1 5/16	187
10	M20	1140	219	1175	32	38	32	32	10	24	85
11	3/4	36 1/8	8 3/8	37 1/2	1 1/4	1 1/2	1 1/4	1 1/4	3/8	1 5/16	219
11	M20	918	219	953	32	38	32	32	10	24	99
12	1	39 1/4	8 3/8	41 1/8	1 5/8	2	1 1/2	1 5/8	1/2	1 1/4	253
12	M24	997	219	1045	41	51	38	41	13	32	115
13	1	49 1/2	8 3/8	51 3/8	1 5/8	2	1 1/2	1 5/8	1/2	1 1/4	287
13	M24	1257	219	1305	41	51	38	41	13	32	130
14	1 1/4	50 1/4	8 3/8	53	1 3/4	3	2	2	1/2	1 1/2	303
14	M30	1276	219	1346	44	76	51	51	13	38	137
15	1 1/4	49 3/4	8 3/8	52 1/2	1 3/4	3	2	2	5/8	1 1/2	420
15	M30	1264	219	1334	44	76	51	51	16	38	191
16	1 1/2	60	8 3/8	62 7/8	2	3	2 1/2	2 3/8	3/4	1 3/4	550
16	M36	1524	219	1597	51	76	64	60	19	44	249
17	1 3/4	68 1/2	8 3/8	71 1/8	2 3/8	3	2 1/2	2 3/8	3/4	2	733
17	M42	1740	219	1807	67	76	64	60	19	51	332
18	2	66	12 3/4	69 7/8	2 7/8	4	3	2 7/8	3/4	2 3/8	1122
18	M48	1676	324	1775	73	102	76	73	19	60	509
19	2 1/4	75 3/4	12 3/4	80 1/8	3 1/2	4 1/2	3	3 1/8	3/4	2 5/8	1310
19	M56	1924	324	2035	89	114	76	79	19	67	594
20	2 1/2	90	12 3/4	94 3/8	3 7/8	4 1/2	4	3 3/8	1	2 7/8	1872
20	M64	2286	324	2397	98	114	102	86	25	73	849
21	2 3/4	100	12 3/4	104 3/8	4 1/4	4 1/2	4	3 3/8	1	3 3/8	2052
21	M72	2540	324	2651	108	114	102	92	25	79	931
22	3	124 1/2	12 3/4	129 3/8	4 1/4	5	4	3 3/8	1	3 3/8	2831
22	M80x6	3162	324	3286	108	127	102	98	25	86	1284

Ordering: Specify Figure Number (Travel Series), Type, Size, Hot Load, Cold Load, Movement and Direction of Movement (from the Cold/Installed position to the Hot/Operating position), and Hanger Identification Number (if any). Specify any other optional feature(s) as necessary.

Pins for attachment to the structure are not included with the unit and must be ordered separately as a Figure 291, shown on page 8 of this catalog. For ordering specify Figure Number, pin diameter and finish.

For corrosion resistant units specify the Figure Number with the letter prefix "C", e.g. C910

For metric units specify the Figure Number with the letter prefix "M" e.g. M910 or MC910.

DIMENSIONS	TEMPERATURE	LOADS	WEIGHT
INCHES	FAHRENHEIT	POUNDS	POUNDS
MILLIMETERS	CELSIUS	NEWTONS	KILOGRAMS

SERIES 980 TYPE D

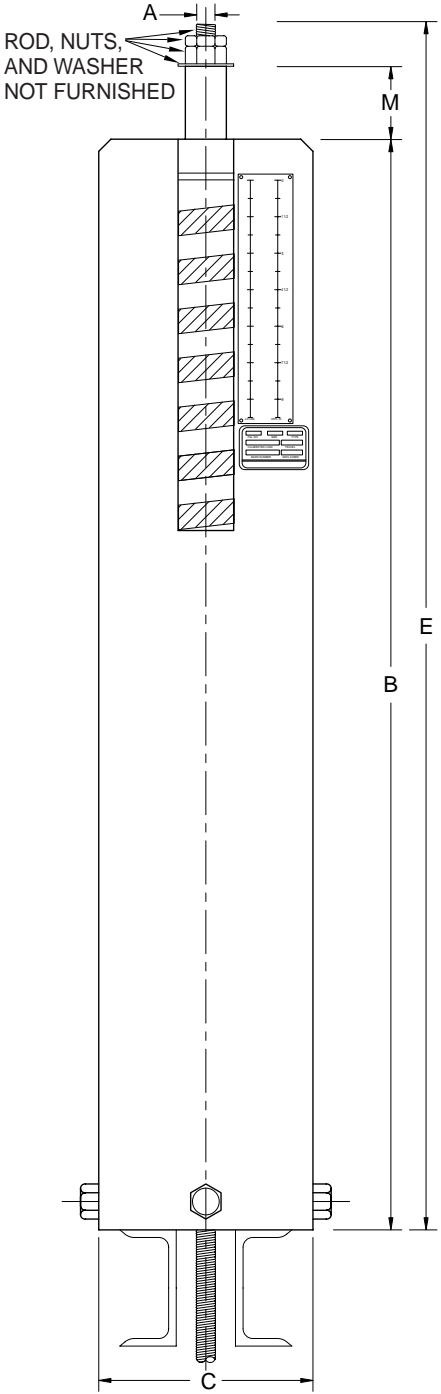

HANGER SIZE	ROD SIZE A	CASE LENGTH B	CASE DIA. C	ROD TAKEOUT E	HGT. OF SPACER M	APPROX. WEIGHT EACH
0	1/2	27	4	36 1/4	8 1/2	32
0	M12	686	102	921	216	15
1	1/2	29 3/8	4	38 5/8	8 1/2	34
1	M12	746	102	981	216	15
2	1/2	30 3/8	4	39 5/8	8 1/2	38
2	M12	772	102	1006	216	17
3	1/2	29 1/2	5 9/16	38 3/4	8 1/2	52
3	M12	749	141	984	216	24
4	1/2	32	5 9/16	41 1/4	8 1/2	62
4	M12	813	141	1048	216	28
5	1/2	34 3/4	5 9/16	44	8 1/2	68
5	M12	883	141	1118	216	31
6	5/8	34	6 5/8	43 1/2	8 1/2	90
6	M16	864	168	1105	216	41
7	5/8	37 7/8	6 5/8	47 1/2	8 1/2	88
7	M16	962	168	1207	216	40
8	5/8	39 3/4	6 5/8	49 1/2	8 1/2	106
8	M16	1010	168	1257	216	48
9	3/4	39 7/8	8 5/8	49 1/2	8 3/8	170
9	M20	1013	219	1257	213	77
10	3/4	44 7/8	8 5/8	54 3/4	8 5/8	187
10	M20	1140	219	1391	219	85
11	3/4	36 1/8	8 5/8	46	8 5/8	219
11	M20	918	219	1168	219	99
12	1	39 1/4	8 5/8	49 3/4	9	253
12	M24	997	219	1264	229	115
13	1	49 1/2	8 5/8	60	9	287
13	M24	1257	219	1524	229	130
14	1 1/4	50 1/4	8 5/8	61 1/2	9 1/4	303
14	M30	1276	219	1562	235	137
15	1 1/4	49 3/4	8 5/8	60 3/4	9 1/8	420
15	M30	1264	219	1543	232	191
16	1 1/2	60	8 5/8	71 3/4	9 1/2	550
16	M36	1524	219	1822	241	249
17	1 3/4	68 1/2	8 5/8	80 7/8	9 3/4	733
17	M42	1740	219	2054	248	332
18	2	66	12 3/4	79	10	1122
18	M48	1676	324	2007	254	509
19	2 1/4	75 3/4	12 3/4	89	10 1/4	1310
19	M56	1924	324	2261	260	594
20	2 1/2	90	12 3/4	104 1/4	10 1/2	1872
20	M64	2286	324	2648	267	849
21	2 3/4	100	12 3/4	114 7/8	10 3/4	2052
21	M72	2540	324	2918	273	931
22	3	124 1/2	12 3/4	140	11	2831
22	M80x6	3162	324	3556	279	1284

Ordering: Specify Figure Number (Travel Series), Type, Size, Hot Load, Cold Load, Movement and Direction of Movement (from the Cold/Installed position to the Hot/Operating position), and Hanger Identification Number (if any). Specify any other optional feature(s) as necessary.

For corrosion resistant units specify the Figure Number with the letter prefix "C", e.g. C980

For metric units specify the Figure Number with the letter prefix "M" e.g. M980 or MC980.

DIMENSIONS		TEMPERATURE	LOADS	WEIGHT
INCHES	FAHRENHEIT		POUNDS	POUNDS
MILLIMETERS	CELSIUS		NEWTONS	KILOGRAMS

VARIABLE SPRING SUPPORTS

SERIES 980 TYPE E

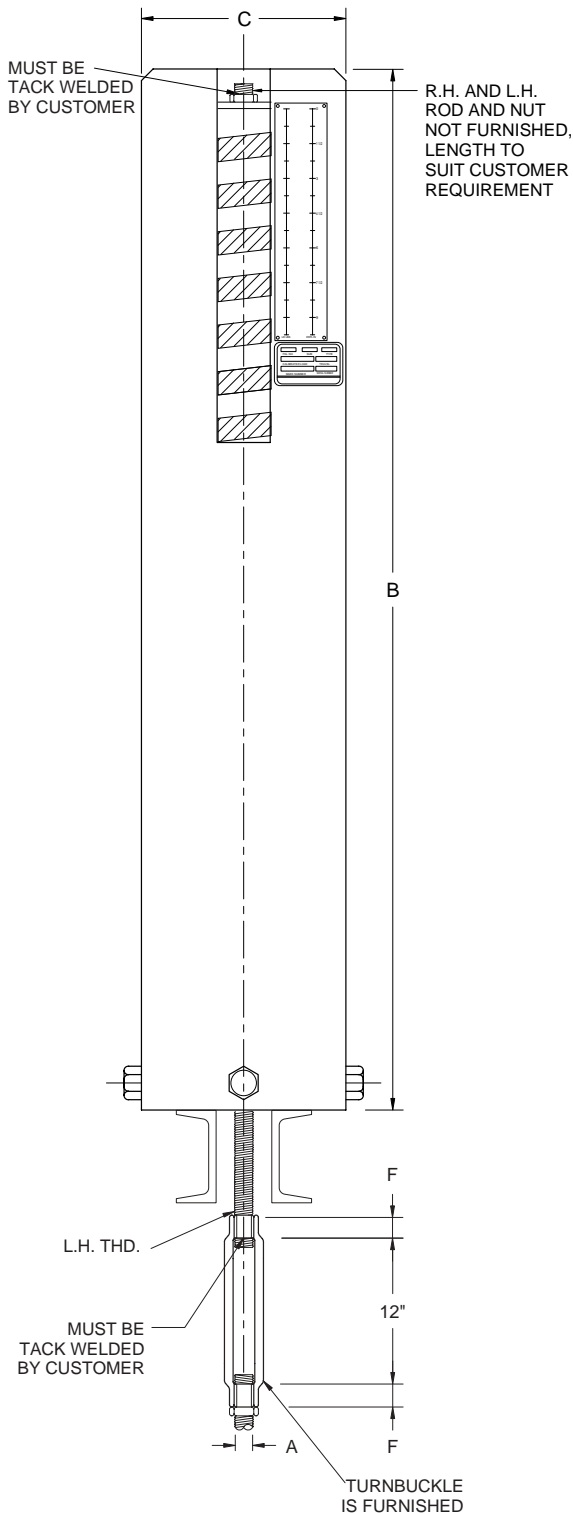

HANGER SIZE	ROD SIZE A	CASE LENGTH B	CASE DIAMETER C	MIN. THD. ENGMT F	APPROX. WEIGHT EACH
0	1/2	27	4	7/8	32
0	M12	686	102	22	15
1	1/2	29 3/8	4	7/8	34
1	M12	746	102	22	15
2	1/2	30 3/8	4	7/8	38
2	M12	772	102	22	17
3	1/2	29 1/2	5 9/16	7/8	52
3	M12	749	141	22	24
4	1/2	32	5 9/16	7/8	62
4	M12	813	141	22	28
5	1/2	34 3/4	5 9/16	7/8	68
5	M12	883	141	22	31
6	5/8	34	6 5/8	1 1/8	90
6	M16	864	168	29	41
7	5/8	37 7/8	6 5/8	1 1/8	88
7	M16	962	168	29	40
8	5/8	39 3/4	6 5/8	1 1/8	106
8	M16	1010	168	29	48
9	3/4	39 7/8	8 5/8	1 1/4	170
9	M20	1013	219	32	77
10	3/4	44 7/8	8 5/8	1 1/4	187
10	M20	1140	219	32	85
11	3/4	36 1/8	8 5/8	1 1/4	219
11	M20	918	219	32	99
12	1	39 1/4	8 5/8	1 5/8	253
12	M24	997	219	41	115
13	1	49 1/2	8 5/8	1 5/8	287
13	M24	1257	219	41	130
14	1 1/4	50 1/4	8 5/8	1 3/4	303
14	M30	1276	219	44	137
15	1 1/4	49 3/4	8 5/8	1 3/4	420
15	M30	1264	219	44	191
16	1 1/2	60	8 5/8	2	550
16	M36	1524	219	51	249
17	1 3/4	68 1/2	8 5/8	2 5/8	733
17	M42	1740	219	67	332
18	2	66	12 3/4	2 7/8	1122
18	M48	1676	324	73	509
19	2 1/4	75 3/4	12 3/4	3 1/2	1310
19	M56	1924	324	89	594
20	2 1/2	90	12 3/4	3 7/8	1872
20	M64	2286	324	98	849
21	2 3/4	100	12 3/4	4 1/4	2052
21	M72	2540	324	108	931
22	3	124 1/2	12 3/4	4 1/4	2831
22	M80X6	3162	324	108	1284

Ordering: Specify Figure Number (Travel Series), Type, Size, Hot Load, Cold Load, Movement and Direction of Movement (from the Cold/Installed position to the Hot/Operating position), and Hanger Identification Number (if any). Specify any other optional feature(s) as necessary.

For corrosion resistant units specify the Figure Number with the letter prefix "C", e.g. C980

For metric units specify the Figure Number with the letter prefix "M" e.g. M980 or MC980.

DIMENSIONS	TEMPERATURE	LOADS	WEIGHT
INCHES	FAHRENHEIT	POUNDS	POUNDS
MILLIMETERS	CELSIUS	NEWTONS	KILOGRAMS

SERIES 980 - TYPE F

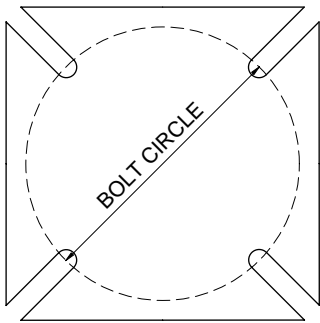
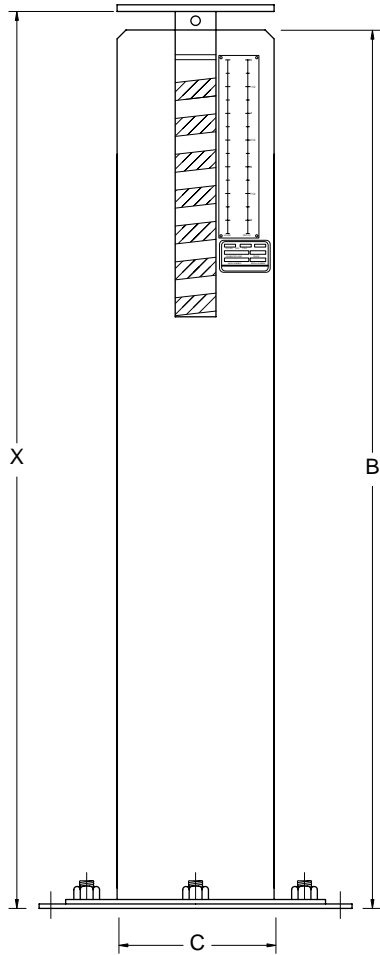

SIZE	CASE LNTH. B	CASE DIA. C	BOTTOM FLANGE BOLT DIA.	BOTTOM FLANGE	BOLT CIRCLE		OVERALL LNTH. X **		LOAD FLANGE DIA.	LOAD FLANGE THICK.	APPROX. WGT. EACH
					MIN.	MAX.	MIN.	MAX.			
0	25½	4	⅝	¼ x 7½ x 7½	7	9¾	27	29	3⅞	¼	50
0	648	102	16	6 x 191 x 191	178	248	686	737	98	6	23
1	27⅝	4	⅝	¼ x 7½ x 7½	7	9¾	29⅞	31⅞	3⅞	¼	50
1	702	102	16	6 x 191 x 191	178	248	740	791	98	6	23
2	31⅝	4	⅝	¼ x 7½ x 7½	7	9¾	33	35⅞	3⅞	¼	56
2	803	102	16	6 x 191 x 191	178	248	841	892	98	6	25
3	28	5⅞	¾	¼ x 7½ x 7½	7¾	9¾	29½	31½	5⅞	¼	80
3	711	141	19	6 x 191 x 191	197	248	749	800	137	6	36
4	30⅞	5⅞	¾	¼ x 7½ x 7½	7¾	9¾	31⅞	33⅞	5⅞	¼	90
4	772	141	19	6 x 191 x 191	197	248	810	860	137	6	41
5	33⅞	5⅞	¾	¼ x 7½ x 7½	7¾	9¾	34½	36⅞	5⅞	¼	99
5	841	141	19	6 x 191 x 191	197	248	876	930	137	6	45
6	32¾	6⅞	¾	⅜ x 9 x 9	9¼	10½	34	36¼	6⅞	¼	130
6	832	168	19	10 x 229 x 229	235	267	864	921	162	6	59
7	38	6⅞	¾	⅜ x 9 x 9	9¼	10½	39⅞	41⅞	6⅞	¼	129
7	965	168	19	10 x 229 x 229	235	267	1013	1064	162	6	59
8	38¾	6⅞	¾	⅜ x 9 x 9	9¼	10½	40	42	6⅞	¼	140
8	984	168	19	10 x 229 x 229	235	267	1016	1067	162	6	64
9	38	8⅞	¾	½ x 13¼ x 13¼	10⅞	16¼	40	42	8⅞	½	240
9	965	219	19	13 x 337 x 337	268	413	1016	1067	213	13	109
10	42⅞	8⅞	¾	½ x 13¼ x 13¼	10⅞	16¼	44⅞	46⅞	8⅞	½	260
10	1089	219	19	13 x 337 x 337	268	413	1140	1191	213	13	118
11	34⅞	8⅞	¾	½ x 13¼ x 13¼	10⅞	16¼	36⅞	38⅞	8⅞	½	280
11	867	219	19	13 x 337 x 337	268	413	918	968	213	13	127
12	36⅞	8⅞	¾	½ x 13¼ x 13¼	10⅞	16¼	38⅞	40⅞	8⅞	½	310
12	930	219	19	13 x 337 x 337	268	413	981	1032	213	13	141
13	46⅞	8⅞	¾	½ x 13¼ x 13¼	10⅞	16¼	48⅞	50⅞	8⅞	½	330
13	1191	219	19	13 x 337 x 337	268	413	1241	1292	213	13	150
14	47⅞	8⅞	¾	½ x 13¼ x 13¼	10⅞	16¼	49⅞	51⅞	8⅞	½	340
14	1203	219	19	13 x 337 x 337	268	413	1254	1305	213	13	154
15	47⅞	8⅞	¾	½ x 13¼ x 13¼	10⅞	16¼	49⅞	51⅞	8⅞	½	440
15	1203	219	19	13 x 337 x 337	268	413	1254	1305	213	13	200
16	56½	8⅞	¾	½ x 13¼ x 13¼	10⅞	16¼	58½	60½	8⅞	½	560
16	1435	219	19	13 x 337 x 337	268	413	1486	1537	213	13	254
17	64¾	8⅞	¾	½ x 13¼ x 13¼	10⅞	16¼	66¾	68¾	8⅞	½	750
17	1645	219	19	13 x 337 x 337	268	413	1695	1746	213	13	340
18	61⅞	12¾	¾	⅝ x 17¼ x 17¼	15¾	21	63¾	65¾	12½	½	1120
18	1565	324	19	16 x 438 x 438	400	533	1619	1670	318	13	508
19	70⅞	12¾	¾	⅝ x 17¼ x 17¼	15¾	21	72¾	74¾	12½	½	1220
19	1794	324	19	16 x 438 x 438	400	533	1848	1899	318	13	553
20	83⅞	12¾	¾	⅝ x 17¼ x 17¼	15¾	21	86¾	88¾	12½	½	1700
20	2124	324	19	16 x 438 x 438	400	533	2191	2242	318	13	771
21	92⅞	12¾	¾	⅝ x 17¼ x 17¼	15¾	21	95	97	12½	½	1810
21	2359	324	19	16 x 438 x 438	400	533	2413	2464	318	13	821
22	117⅞	12¾	¾	⅝ x 17¼ x 17¼	15¾	21	119¼	121¼	12½	½	2450
22	2975	324	19	16 x 438 x 438	400	533	3029	3080	318	13	1111

** The Installed Height should be the mid-point between the Maximum and Minimum Overall Height "X", plus the thickness of the Load Flange, and plus any DOWN piping movement when applicable.

Ordering: Specify Figure Number (Travel Series), Type, Size, Hot Load, Cold Load, Movement and Direction of Movement (from the Cold/Installed position to the Hot/Operating position), Dimension X (Installed Height) and Hanger Identification Number (if any). Specify any other optional feature(s) as necessary.

For corrosion resistant units specify the Figure Number with the letter prefix "C", e.g. C980
 For metric units specify the Figure Number with the letter prefix "M" e.g. M980 or MC980.

DIMENSIONS		TEMPERATURE	LOADS	WEIGHT
INCHES		FAHRENHEIT	POUNDS	POUNDS
MILLIMETERS		CELSIUS	NEWTONS	KILOGRAMS

VARIABLE SPRING SUPPORTS

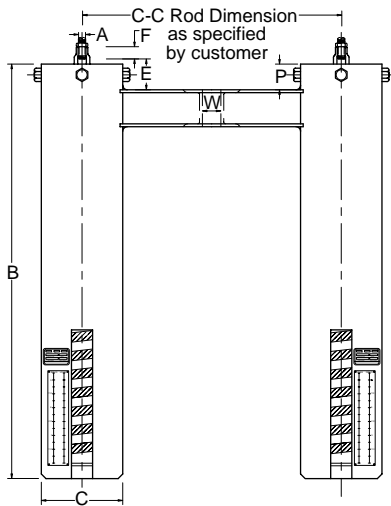

Ordering: Specify Figure Number (Travel Series), Type, Size, Total Load, Hot Load per spring, Cold Load per spring, Movement and Direction of Movement (from the Cold/Installed position to the Hot/Operating position), Center to Center of Rods dimension and Hanger Identification Number (if any). Specify any other optional feature(s) as necessary.

For corrosion resistant units specify the Figure Number with the letter prefix "C", e.g. C980

For metric units specify the Figure Number with the letter prefix "M" e.g. M980 or MC980.

FIGURE 980 TYPE G

HANGER SIZE	ROD SIZE A	CASE LENGTH B	CASE DIAMETER C	ROD TAKEOUT E	MIN. THD. ENGMT F	CHANNEL SIZE	MAX. C - C	CHANNEL SPACING W	P	APPROX. WEIGHT EACH
0	1/2	27	4	1 3/8	7/8	C3 x 4.1	24	5/8	1 1/2	64
0	M12	686	102	35	22	C75 x 6	610	16	38	29
1	1/2	29 3/8	4	1 3/8	7/8	C3 x 4.1	24	5/8	1 1/2	68
1	M12	746	102	35	22	C75 x 6	610	16	38	31
2	1/2	30 3/8	4	1 3/8	7/8	C3 x 4.1	24	5/8	1 1/2	76
2	M12	772	102	35	22	C75 x 6	610	16	38	34
3	1/2	29 1/2	5 5/16	1 7/8	7/8	C3 x 4.1	30	3/4	2	104
3	M12	749	141	48	22	C75 x 6	762	19	51	47
4	1/2	32	5 5/16	1 7/8	7/8	C3 x 4.1	30	3/4	2	124
4	M12	813	141	48	22	C75 x 6	762	19	51	56
5	1/2	34 3/4	5 5/16	1 7/8	7/8	C3 x 4.1	30	3/4	2	136
5	M12	883	141	48	22	C75 x 6	762	19	51	62
6	5/8	34	6 3/8	1 7/8	1 1/8	C3 x 4.1	36	1	2	180
6	M16	864	168	48	29	C75 x 6	914	25	51	82
7	5/8	37 7/8	6 3/8	1 7/8	1 1/8	C3 x 4.1	36	1	2	176
7	M16	962	168	48	29	C75 x 6	914	25	51	80
8	5/8	39 3/4	6 3/8	1 7/8	1 1/8	C3 x 4.1	36	1	2	212
8	M16	1010	168	48	29	C75 x 6	914	25	51	96
9	3/4	39 7/8	8 5/8	2 7/8	1 1/4	C4 x 5.4	36	1 1/4	3	340
9	M20	1013	219	73	32	C100 x 8	914	32	76	154
10	3/4	44 7/8	8 5/8	2 7/8	1 1/4	C4 x 5.4	36	1 1/4	3	374
10	M20	1140	219	73	32	C100 x 8	914	32	76	170
11	3/4	36 1/8	8 5/8	2 7/8	1 1/4	C4 x 5.4	36	1 1/4	3	438
11	M20	918	219	73	32	C100 x 8	914	32	76	199
12	1	39 1/4	8 5/8	3 7/8	1 5/8	C5 x 6.7	36	1 1/2	4	506
12	M24	997	219	98	41	C130 x 10	914	38	102	230
13	1	49 1/2	8 5/8	3 7/8	1 5/8	C5 x 6.7	36	1 1/2	4	574
13	M24	1257	219	98	41	C130 x 10	914	38	102	260
14	1 1/4	50 1/4	8 5/8	4 1/8	1 3/4	C5 x 6.7	36	1 1/2	4	606
14	M30	1276	219	105	44	C130 x 10	914	38	102	275
15	1 1/4	49 3/4	8 5/8	4 1/8	1 3/4	C8 x 11.5	36	2 1/8	4	840
15	M30	1264	219	105	44	C200 x 17	914	54	102	381
16	1 1/2	60	8 5/8	3 7/8	2	C8 x 11.5	36	2 1/8	4	1100
16	M36	1524	219	98	51	C200 x 17	914	54	102	499
17	1 3/4	68 1/2	8 5/8	3 5/8	2 5/8	C8 x 11.5	36	2 1/8	4	1466
17	M42	1740	219	92	67	C200 x 17	914	54	102	665
18	2	66	12 3/4	3 7/8	2 7/8	C12 x 20.7	42	2 3/8	4	2244
18	M48	1676	324	98	73	C130 x 31	1067	60	102	1018
19	2 1/4	75 3/4	12 3/4	3 7/8	3 1/2	C12 x 20.7	42	2 5/8	4	2620
19	M56	1924	324	98	89	C130 x 31	1067	67	102	1188
20	2 1/2	90	12 3/4	3 7/8	3 7/8	C12 x 20.7	40	2 7/8	4	3744
20	M64	2286	324	98	98	C130 x 31	1016	73	102	1698
21	2 3/4	100	12 3/4	3 7/8	4 1/4	C15 x 33.9	48	3 1/8	4	4104
21	M72	2540	324	98	108	C380 x 50	1219	79	102	1862
22	3	124 1/2	12 3/4	3 7/8	4 1/4	C15 x 33.9	48	3 3/8	4	5662
22	M80x6	3162	324	98	108	C380 x 50	1219	86	102	2568

DIMENSIONS		TEMPERATURE	LOADS	WEIGHT
INCHES	FAHRENHEIT		POUNDS	POUNDS
MILLIMETERS	CELSIUS		NEWTONS	KILOGRAMS

REFERENCE DATA – METRIC CONVERSION CHART

	TO CONVERT FROM	TO	MULTIPLY BY
Angle	degree	radian (rad)	1.745329×10^{-2}
	radian (rad)	degree	5.729578×10^{-1}
Area	foot ²	square meter (m ²)	9.290304×10^{-2}
	inch ²	square meter (m ²)	6.451600×10^{-4}
	circular mil	square meter (m ²)	5.067075×10^{-10}
	square centimeter (cm ²)	square inch (in ²)	1.550003×10^{-1}
	square meter (m ²)	foot ²	1.076391×10^{-1}
	square meter (m ²)	inch ²	1.550003×10^{-3}
	square meter (m ²)	circular mil	1.973525×10^{-9}
Bending Moment or Torque	lbf•ft	newton meter (N•m)	1.355818
	lbf•in	newton meter (N•m)	1.129848×10^{-1}
	N•m	lbf•ft	7.375621×10^{-1}
	N•m	lbf•in	8.850748
Force	pounds-force (lbf)	newtons (N)	4.448222
Length	foot (ft)	meter (m)	3.048000×10^{-1}
	inch (in)	meter (m)	2.540000×10^{-2}
	mil	meter (m)	2.540000×10^{-5}
	inch (in)	micrometer (µm)	2.540000×10^{-4}
	meter (m)	foot (ft)	3.280840
	meter (m)	inch (in)	3.937008×10^{-1}
	meter (m)	mil	3.937008×10^{-4}
	micrometer (µm)	Inch (in)	3.937008×10^{-5}
Mass	ounce (avoirdupois)	kilogram (kg)	2.834952×10^{-2}
	pound (avoirdupois)	kilogram (kg)	4.535924×10^{-1}
	on (short, 2000 lb)	kilogram (kg)	9.071847×10^{-2}
	on (long, 2240 lb)	kilogram (kg)	1.016047×10^{-3}
	kilogram (kg)	ounce (avoirdupois)	3.527396×10^{-1}
	kilogram (kg)	pound (avoirdupois)	2.204622
	kilogram (kg)	ton (short 2000 lb)	1.102311×10^{-3}
	kilogram (kg)	ton (long 2240 lb)	9.842064×10^{-4}
Mass Per Unit Length	lb/ft	kilogram per meter (kg/m)	1.488164
	lb/in	kilogram per meter (kg/m)	1.785797×10^{-1}
	kg/m	lb/ft	6.719689×10^{-1}
	kg/m	lb/in	5.599741×10^{-2}
Mass Per Unit Volume	lb/ft ³	kilogram per cubic meter (kg/m ³)	1.601846×10^{-1}
	lb/in ³	kilogram per cubic meter (kg/m ³)	2.767990×10^{-4}
	kg/m ³	lb/ft ³	6.242797×10^{-2}
	kg/m ³	lb/in ³	3.612730×10^{-5}
	lbs/ft ³	lbs/in ³	1.728000×10^{-3}
Mass Per Area Unit	lb/ft ²	kilogram per square meter (kg/m ²)	4882428
	kg/m ²	pound per square foot (lb/ft ²)	2.048161×10^{-1}
Pressure or Stress	lbf/in ² (psi)	pascal (Pa)	6.894757×10^{-3}
	kip/in ² (ksi)	pascal (Pa)	6.894757×10^{-6}
	lbf/in ² (psi)	megapascals (MPa)	6.894757×10^{-3}
	pascal (Pa)	pound force per sq. inch (psi)	1.450377×10^{-4}
	pascal (Pa)	kip per sq. inch (ksi)	1.450377×10^{-7}
	megapascals (MPa)	lbf/in ² (psi)	1.450377×10^{-2}
Section Properties	section modulus S (in ³)	S (m ³)	1.638706×10^{-5}
	section modulus S (M ³)	S (in ³)	6.102374×10^{-4}
	moment of inertia I (in ⁴)	I (m ⁴)	4.162314×10^{-7}
	moment of inertia I (M ⁴)	I (in ⁴)	2.402510×10^{-6}
	modulus of elasticity E (psi)	E (Pa)	6.894757×10^{-3}
	modulus of elasticity E (Pa)	E (psi)	1.450377×10^{-4}
Temperature	degree Fahrenheit	degree Celsius	$t^{\circ C} = t^{\circ F} - 32$ / 1.8
	degree Celsius	degree Fahrenheit	$t^{\circ F} = 1.8 t^{\circ C} + 32$
Volume	foot ³	cubic meter (m ³)	2.831685×10^{-2}
	inch ³	cubic meter (m ³)	1.638706×10^{-2}
	cubic centimeter (cm ³)	cubic inch (in ³)	6.102374×10^{-2}
	cubic meter (m ³)	foot ³	3.531466×10^{-1}
	cubic meter (m ³)	inch ³	6.102376×10^{-4}
	gallon (U.S. liquid)	cubic meter (m ³)	3.785412×10^{-3}

ABBREVIATIONS

AISC	= American Institute of Steel Construction
AISI	= American Iron & Steel Institute
ANSI	= American National Standards Institute
ASTM	= American Society for Testing & Materials
AWWA	= American Water Works Association
Dia.	= Diameter
Ft.	= Feet
Ga	= Gauge
I.D.	= Inside Diameter
In.	= Inch
Lbs.	= Pounds
Max.	= Maximum
Min.	= Minimum
MSS	= Manufacturers' Standardization Society
NFPA	= National Fire Protection Association
O.D.	= Outside Diameter
Oz.	= Ounces
psi	= Pounds Per Square Inch
PVC	= Poly Vinyl Chloride
UNC	= Unified Course Threads
UNCR	= Unified Course Threads (Rounded Root)

METRIC SYMBOLS

cm	= centimeter
kg	= kilogram
kN	= kilonewton
m	= meter
µm	= micrometer
mm	= millimeter
MPa	= megapascal
N	= newton
Nm	= newton-meter
Pa	= pascal

TECHNICAL INFORMATION

PIPE WEIGHTS FOR STANDARD AND HEAVY WEIGHT PIPE

Nominal Pipe Size	PIPE DATA				PIPE WEIGHT			
	Pipe Schedule	Outside Dia.		Wall Th'k in	w/ Gas, Air, Steam		w/ Water	
		in	mm		lbs/ft	N/m	lbs/ft	N/m
½" (15mm)	Std / 40 XS / 80	0.840	22	0.109 0.147	0.9 1.1	12 16	1.0 1.2	14 17
¾" (20mm)	Std / 40 XS / 80	1.050	28	0.113 0.154	1.1 1.5	17 22	1.4 1.7	20 24
1" (25mm)	Std / 40 XS / 80	1.315	34	0.133 0.179	1.7 2.2	25 32	2.1 2.5	30 36
1¼" (32mm)	Std / 40 XS / 80	1.660	42	0.140 0.191	2.3 3.0	33 44	2.9 3.6	43 52
1½" (40mm)	Std / 40 XS / 80	1.900	48	0.145 0.200	2.7 3.6	40 53	3.6 4.4	53 64
2" (50mm)	Std / 40 XS / 80	2.375	60	0.154 0.218	3.7 5.0	53 73	5.1 6.3	75 92
2½" (65mm)	Std / 40 XS / 80	2.875	75	0.203 0.276	5.8 7.7	85 112	7.9 9.5	115 139
3" (80mm)	Std / 40 XS / 80	3.500	89	0.216 0.300	7.6 10	111 150	11 13	157 191
3½" (90mm)	Std / 40 XS / 80	4.000	102	0.226 0.318	9.1 13	133 182	13 16	195 239
4" (100mm)	Std / 40 XS / 80	4.500	114	0.237 0.337	11 15	157 219	16 20	238 291
5" (125mm)	Std / 40 XS / 80	5.563	141	0.258 0.375	15 21	213 303	23 29	340 418
6" (150mm)	Std / 40 XS / 80	6.625	168	0.280 0.432	19 29	277 417	31 40	460 582
8" (200mm)	Std / 40 XS / 80	8.625	219	0.322 0.500	29 43	417 633	50 63	733 922
10" (250mm)	Std / 40 XS / 60	10.75	273	0.365 0.500	40 55	591 799	75 87	1090 1271
12" (300mm)	Std XS	12.75	235	0.375 0.500	50 65	723 955	99 112	1439 1641
14" (350mm)	Std / 30 XS	14.00	355.6	0.375 0.500	55 72	796 1052	114 130	1669 1892
16" (400mm)	Std / 30 XS / 40	16.00	406.4	0.375 0.500	63 83	913 1208	142 159	2069 2326
18" (450mm)	Std XS	18.00	457.2	0.375 0.500	71 93	1030 1364	172 192	2509 2800
20" (500mm)	Std / 20 XS / 30	20.00	508.0	0.375 0.500	79 104	1147 1520	205 227	2988 3313
24" (600mm)	Std / 20 XS	24.00	609.6	0.375 0.500	95 125	1381 1831	279 306	4067 4460
30" (750mm)	Std XS / 20	30.00	762.0	0.375 0.500	119 158	1731 2299	410 444	5983 6478
36" (900mm)	Std XS / 20	36.00	914.4	0.375 0.500	143 190	2082 2766	566 607	8256 8853
42" (1050mm)	Std XS / 20	42.00	1066.8	0.375 0.500	167 222	2433 3234	746 794	10888 11587

Pipe Weights are based on Carbon Steel pipe

USEFUL WEIGHT FORMULAS

PIPE

$$\text{Weight (lb/ft)} = 10.68 \times T \times (D - T) \times F$$

PIPE CONTENTS

$$\text{Weight (lb/ft)} = 0.3405 \times G \times (D - 2T)^2$$

LEGEND

- D = Outside Diameter (inches)
- F = Material Weight Factor
- G = Specific Gravity of Pipe Contents
Normally 1.0 for water, 0 for air and steam.
- L = Length (inches)
- T = Pipe Wall, Plate, or Bar Thickness (inches)
- W = Width (inches)

PLATE AND BAR

$$\text{Weight (lb)} = 0.2833 \times T \times W \times L \times F$$

ROUND ROD

$$\text{Weight (lb/ft)} = 2.67D^2$$

MATERIAL WEIGHT FACTORS

Carbon Steel & Cr-Mo	1.00
Aluminum	0.35
Brass	1.12
Cast Iron	0.91
Copper	1.14
Ferritic stainless steel	0.95
Austenitic stainless steel	1.02
Wrought iron	0.98

CALCULATING OF PIPING INSULATION WEIGHT

The weight per foot of insulation is calculated by using the weight factor "X" from the table below and multiplying by the insulation density (lbs/cu-ft).

EXAMPLE: A 16" pipe with 3½" of insulation is found to have a weight factor of 1.49 (from table below). With an insulation density of 11 lb/cu-ft, the calculation for insulation weight is 1.49 x 11 = 16.39

INSULATION WEIGHT FACTOR – X

NOMINAL PIPE SIZE	NOMINAL INSULATION THICKNESS											
	1"	1½"	2"	2½"	3"	3½"	4"	4½"	5"	5½"	6"	
1	.057	.10	.16	.23	.31	.40						
1¼	.051	.12	.15	.22	.30	.39						
1½	.066	.11	.21	.29	.38	.48						
2	.080	.14	.21	.29	.37	.47	.59					
2½	.091	.19	.27	.36	.46	.58	.70	.83				
3	.10	.17	.25	.34	.44	.56	.68	.81				
3½	.15	.23	.31	.41	.54	.66	.7897			
4	.13	.21	.30	.39	.51	.63	.77	.96	1.10			
5	.15	.24	.34	.45	.58	.71	.88	1.04	1.20			
6	.17	.27	.38	.51	.64	.83	.97	1.13	1.34			
8		.34	.47	.66	.80	.97	1.17	1.36	1.56	1.75		
10		.43	.59	.75	.93	1.12	1.32	1.54	1.76	1.99		
12		.50	.68	.88	1.07	1.28	1.52	1.74	1.99	2.24	2.50	
14		.51	.70	.90	1.11	1.34	1.57	1.81	2.07	2.34	2.62	
16		.57	.78	1.01	1.24	1.49	1.74	2.01	2.29	2.58	2.88	
18		.64	.87	1.12	1.37	1.64	1.92	2.21	2.51	2.82	3.14	
20		.70	.96	1.23	1.50	1.79	2.09	2.40	2.73	3.06	3.40	
24		.83	1.13	1.44	1.77	2.10	2.44	2.80	3.16	3.54	3.92	

General Formula: For pipe sizes not shown in the table above (special O.D. pipe, etc.), use the following formula to determine the insulation weight:

$$\text{Insulation Weight: (lb/ft)} = 0.0218 \times I \times T \times (T + D)$$

- Where:** I = Insulation density (lb/cu-ft)
- T = Insulation thickness (inches)
- D = Outside diameter of pipe (inches)

TECHNICAL INFORMATION

COMMON STRUCTURAL SHAPES USED FOR PIPE SUPPORTS

STRUCTURAL SHAPE	SIZE	WEIGHT PER FOOT	DEPTH IN	FLANGE WIDTH IN	THICKNESS IN	SECTION MODULUS IN ³	
ANGLE	L 1½ x 1½ x ¼	2.3	1½	1½	¼	0.13	
	L 2 x 2 x ¼	3.2	2	2	¼	0.25	
	L 2½ x 2½ x ¼	4.1	2½	2½	¼	0.38	
	L 3 x 3 x ¼	4.9	3	3	¼	0.58	
	L 3 x 3 x ⅜	7.2	3	3	⅜	0.83	
	L 3 x 3 x ½	9.4	3	3	½	1.07	
	L 3½ x 3½ x ⅜	8.5	3½	3½	⅜	1.15	
	L 4 x 4 x ⅜	9.8	4	4	⅜	1.52	
	L 4 x 4 x ½	12.8	4	4	½	1.97	
	L 5 x 5 x ½	16.2	5	5	½	3.16	
	L 6 x 6 x ½	19.6	6	6	½	4.61	
	L 6 x 6 x ¾	28.7	6	6	¾	6.66	
CHANNEL	C 3 x 4.1	4.1	3	1⅜	¼	1.10	
	C 4 x 5.4	5.4	4	1⅜	⅝ ₁₆	1.93	
	C 5 x 6.7	6.7	5	1¾	⅝ ₁₆	3.00	
	C 6 x 8.2	8.2	6	1⅞	⅝ ₁₆	4.38	
	C 8 x 11.5	11.5	8	2¼	⅜	8.14	
	C 10 x 15.3	15.3	10	2⅝	⅞ ₁₆	13.50	
	C 12 x 20.7	20.7	12	3	½	21.50	
	C 15 x 33.9	33.9	15	3⅝	⅝ ₈	42.00	
	SQUARE TUBING	ST 2 x 2 x ¼	5.4	2	2	¼	0.77
		ST 3 x 3 x ¼	8.8	3	3	¼	2.10
ST 4 x 4 x ¼		12.2	4	4	¼	4.11	
ST 4 x 4 x ⅜		17.3	4	4	⅜	5.35	
ST 4 x 4 x ½		21.6	4	4	½	6.13	
ST 6 x 6 x ¼		19.0	6	6	¼	10.10	
ST 6 x 6 x ⅜		27.5	6	6	⅜	13.90	
ST 6 x 6 x ½		35.2	6	6	½	16.80	
ST 8 x 8 x ¼		25.8	8	8	¼	18.80	
ST 8 x 8 x ⅜		38.9	8	8	⅜	26.40	
ST 8 x 8 x ½	48.9	8	8	½	32.90		
I-BEAM	S 4 x 7.7	7.7	4	2⅝	⅝ ₁₆	3.04	
	W 4 x 13	13.0	4⅞	4	⅜	5.46	
	W 6 x 12	12.0	6	4	¼	7.31	
	W 6 x 15	15.0	6	6	¼	9.72	
	W 6 x 20	20.0	6¼	6	⅜	13.40	
	W 8 x 18	18.0	8⅞	5¼	⅝ ₁₆	15.20	
	W 8 x 24	24.0	7⅞	6½	⅜	20.90	
	W 8 x 31	31.0	8	8	⅞ ₁₆	27.50	
	W 10 x 22	22.0	10⅞	5¾	⅜	23.20	
	W 10 x 33	33.0	9¼	8	⅞ ₁₆	35.00	
	W 12 x 26	26.0	12¼	6½	⅜	33.40	
	W 12 x 40	40.0	12	8	½	51.90	

Note: Flange thickness for I-Beam and Channel is the “mean” thickness

DISTRIBUTED BY:

PHS
Industries, Inc.

Manufacturer of Pipe Hangers and Supports

434 Latigue Road
Waggaman, LA 70094
Phone - (504) 431-7722
Fax - (504) 431-7900
PHSINDUST@aol.com

WWW.PHSIND.COM