

EP5 Electropneumatic Positioner



**Sturdy, simple,
reliable design**

High gain pilot valve

Built in gauge ports

**Bright visible indicator,
flat or Dome style**

Stainless steel cam

Tapped exhaust port

**Easy to add on Feed-
back Unit F5**

**Simple calibration,
external zero adjust-
ment**



General

The EP5 electropneumatic positioner is adapted from the PMV P5 pneumatic positioner.

This compact and sturdy unit is designed for maximum performance in all types of environments. The EP5 is available in Standard, Intrinsically Safe, Explosion Proof and Fail Freeze versions. A modular feedback unit F5 allows for the addition of limit switches and/or position transmitters, without additional mounting brackets.

Other features include: replaceable filter, gauge ports, dampers, tapped exhaust port for venting of supply media, external zero adjustment and completely sealed cover.

Simple

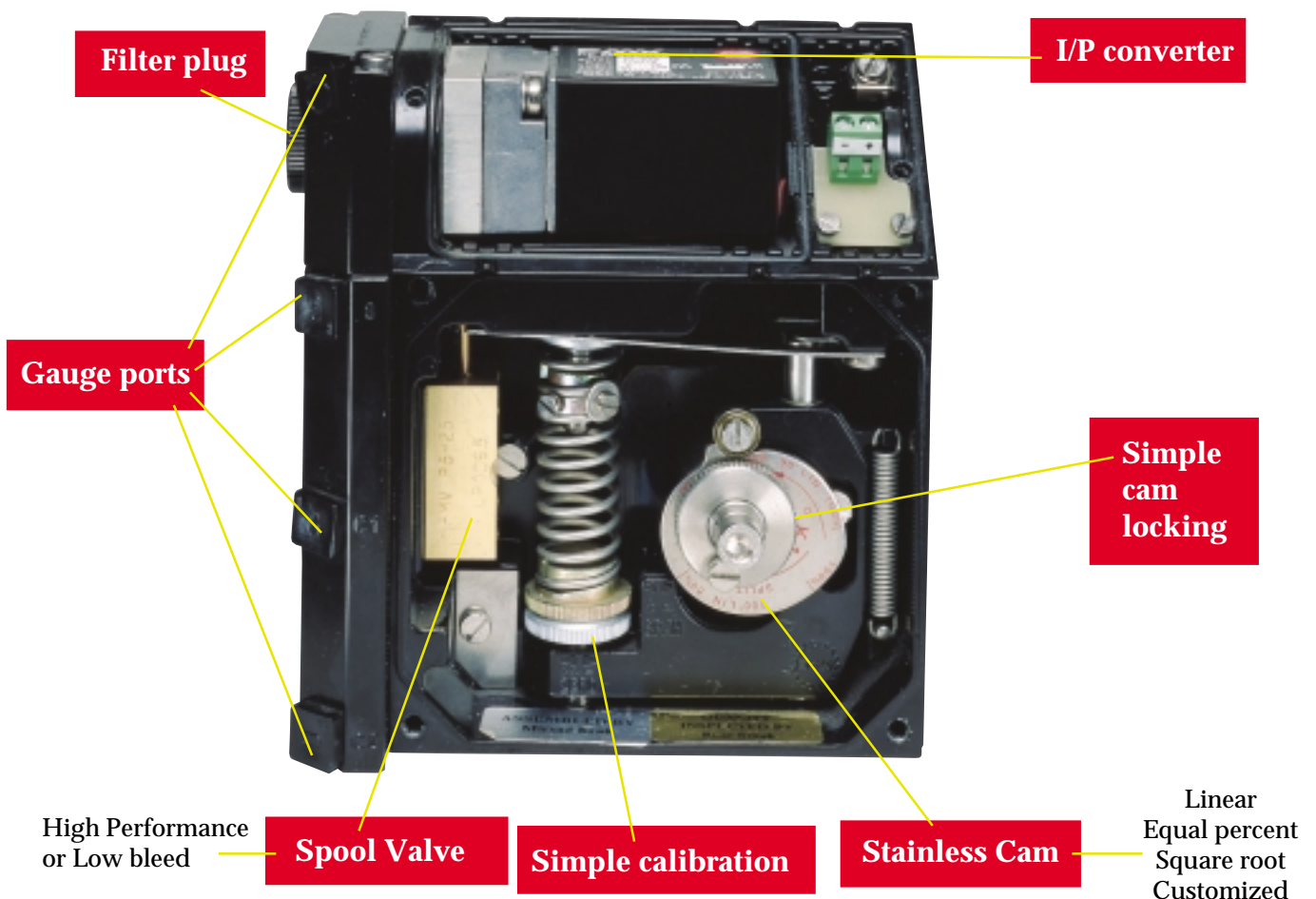

Modular



EP5	For all normal applications
EP5-EX	Explosion Proof
EP5-IS	Intrinsically Safe
EP5-FS	Fail Freeze*

* See PMV datasheet 23746

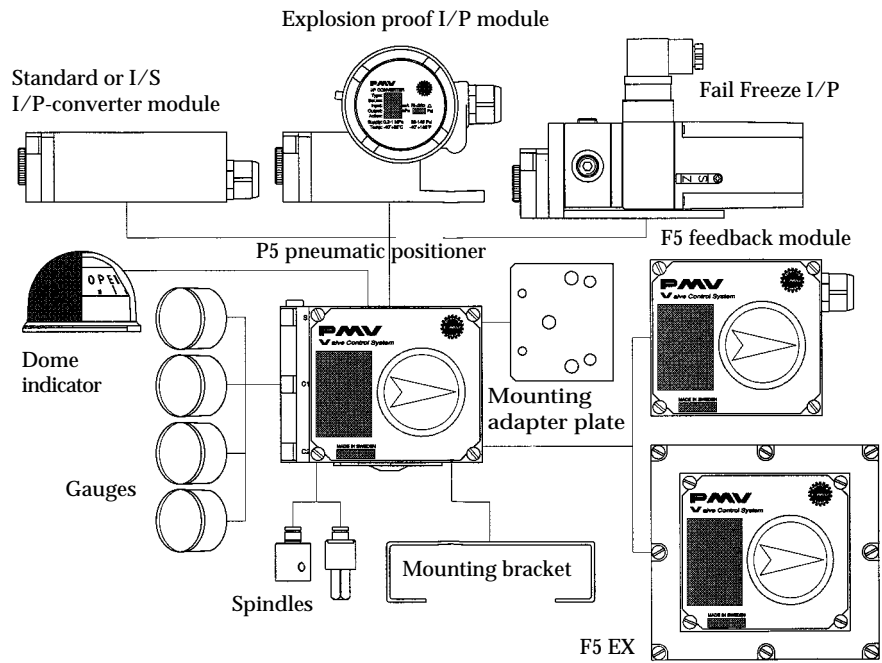

Technical Specifications

Deadband	≤ 0.15%
Input signal	4-20mA
Linearity	≤ 1%*
Hysteresis	≤ 0.75%*
Repeatability	≤ 0.5%*
Air supply	Max 1 MPa/150 Psi, Oil, water and dustfree Min 0.14 MPa/21 Psi
Connector threads	1/4"NPT or G (BSP)
Gauge threads	1/8" NPT or G (BSP)
Conduit entry	1/2" NPT or PG 13.5 (M20)
Terminals	2.5 mm ² (AVG 14) Screw terminals

Low Bleed Version

Gain factor at: 600 KPa/87 Psi	Min. 1000 Kpa/Kpa Min. 66%/ % ISA S75.13-1989
--------------------------------	--

Min: 450 KPa/KPa Min: 30 %/ %

Max. air consumption at supply pressure:

0.2 MPa/29 Psi	6.1 nl/min (0.22 SCFM)	2,7 nl/min (0,1 SCFM)
0.4 MPa/58 Psi	13.6 nl/min (0.48 SCFM)	6,1 nl/min (0,21 SCFM)
0.6 MPa/87 Psi	22 nl/min (0.78 SCFM)	9.9 nl/min (0,35 SCFM)
0.8 MPa/116 Psi	30.5 nl/min (1.08 SCFM)	13,7 nl/min (0,48 SCFM)
1 MPa/145 Psi	39 nl/min (1.38 SCFM)	17,5 nl/min (0,62 SCFM)

Min. air delivery at supply pressure:

0.2 MPa/29 Psi	200 nl/min (6.9 SCFM)	156 nl/min (5,5 SCFM)
0.4 MPa/58 Psi	370 nl/min (12.8 SCFM)	288 nl/min (10,1 SCFM)
0.6 MPa/87 Psi	540 nl/min (18.8 SCFM)	421 nl/min (14,8 SCFM)
0.8 MPa/116 Psi	710 nl/min (24.7 SCFM)	553 nl/min (19,4 SCFM)
1 MPa/145 Psi	880 nl/min (30.6 SCFM)	686 nl/min (24 SCFM)

Input impedance	170-260 Ohms at 20°C (71°F)
RFI influence	Not measurable
Capacitance	Negligible
Position sensitivity	None
Supply pressure effect	0.5%/0.1 MPa (15 Psi)
Temperature range	-20°C to +85°C/ (-4F to +185°F)
Low temp option	-40°C to +85°C (-40°F to +185°F)
Weight	1.5 kg/3.4 lbs
Housing	Die cast aluminum
Surface treatment	ED Epoxy paint, Black
Fasteners	A2/A4 Stainless
Ingress protection	IP 66/NEMA 4

Approvals

Cenelec	Intrinsically safe Flameproof**	EEx ia IIC T4-T6 EEx d IIC T4-T6
FM	Intrinsically safe Explosion proof**	Div.1, Class 1, Group ABCD Div 1, Class 1, Group BCD
CSA	Intrinsically safe Explosion proof**	Div. 1, Class 1, Group ABCD Div 1, Class 1,2,3 Group BCDEFG

*Percent of full scale

**I/P in round housing

Dimensional Drawing

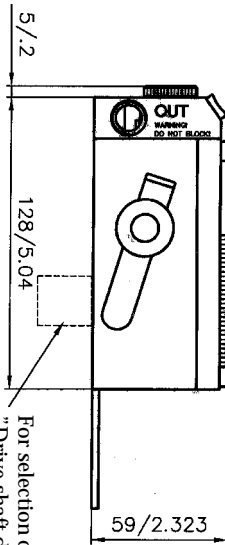
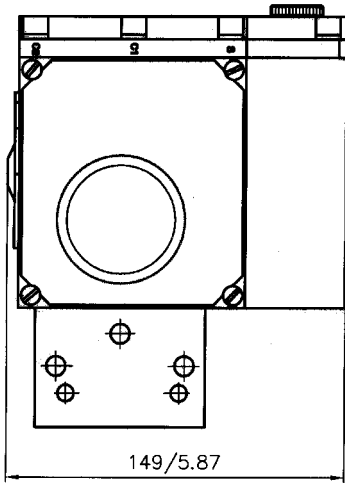

For selection of the feedback-spindle pls see "Drive shaft dimension drawing" SPNDLS.P5

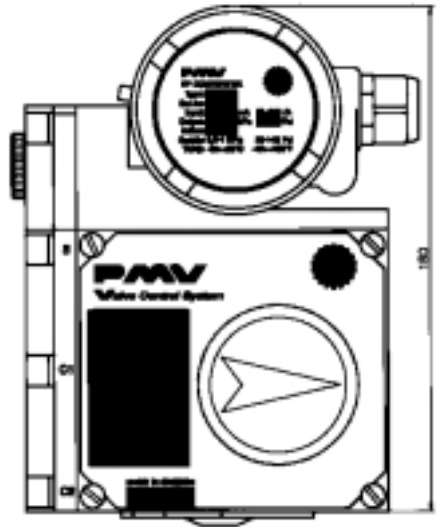

EP5 Explosion proof version

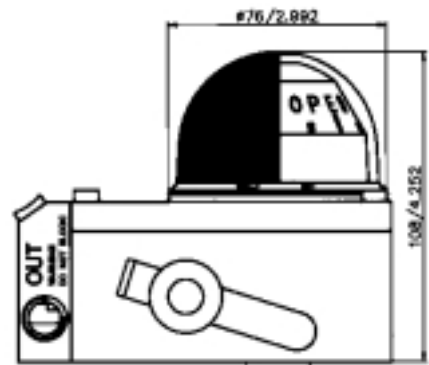
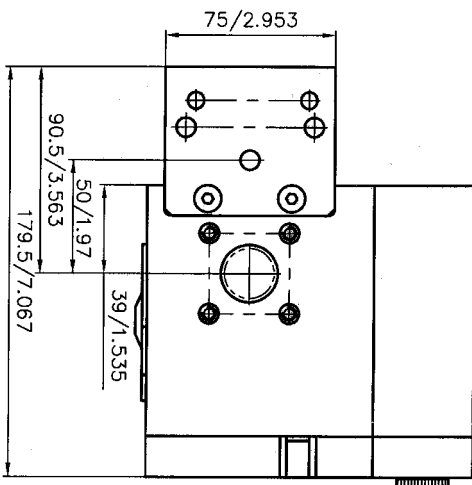
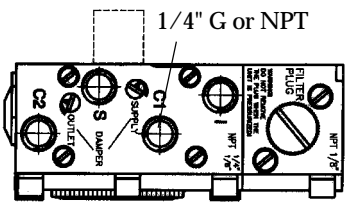

EP5 with H5

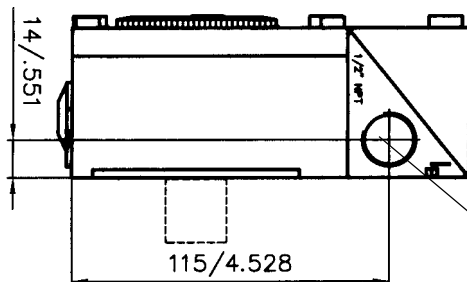

1/2" or PG 13.5 (M20)

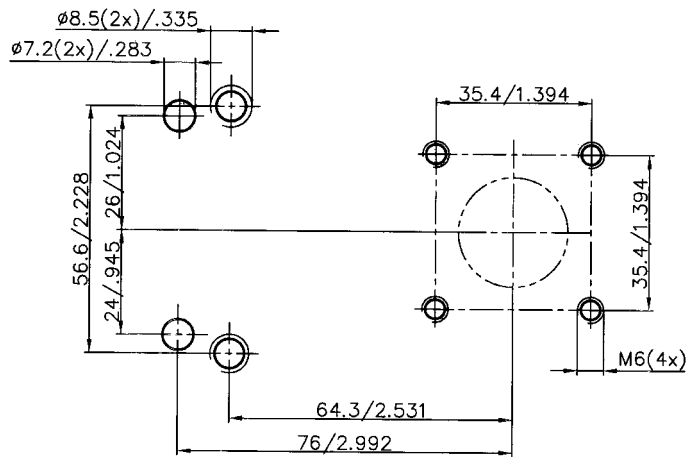

EP5 Footprint

How to order

1. Model	EP5XX	EP5 Double acting pneumatic
	EP5FS	Fail freeze function
	EP5IS	Intrinsically safe, Cenelec, FM, CSA
	EP5EU	Explosion proof Cenelec
	EP5US	Explosion proof CSA, FM
2. Spool valve	HP or LB	High performance or Low bleed
3. Air connection	N or G	NPT 1/4" or G 1/4"
3. Surface treatment	U or M	Epoxy coating or Tufram
4. Spindle	01, 23 etc	01 to 35. See dwg SPNDLSP_5
5. Cam	K01	K01 to K17, K01 = linear 90 deg, standard
6. Front cover	PV9DA	90 deg, Direct, arrow indicator
7. Input signal	4	4-20 input
8. Temperature	N or Q	Nitrile seals -20 deg C, Q=Silicon seals, -40 deg C

* For 30,45 and 60 deg rotation, change PV9 to PV 3, PV4 or PV6.

Example: EP5XX-HPGU-23K01-PV9DA-3Z
 1 2 3 4 5 6 7 8



Palmstiernas Instrument AB
 Korta Gatan 9
 SE-171 54 Solna
 SWEDEN
 Tel: +46 (0) 8 555 106 00
 Fax: +46 (0) 8 555 106 01
 E-mail: info@pmv.nu
 Internet: www.pmv.nu



SUBSIDIARIES

PMV Controls Ltd
 Headlands Business Park
 Ringwood
 Hampshire BH24 3PB
 ENGLAND
 Tel: +44 (0) 1425 48 08 88
 Fax: +44 (0) 1425 48 08 89
 E-mail: sales@pmv-controls.ltd.uk
 Internet: www.pmv-controls.ltd.uk

PMV-USA, Inc
 1440 Lake Front Circle
 Unit 160
 The Woodlands, Texas 77380
 USA
 Tel: +1 281 292 7500
 Fax: +1 281 292 7760
 E-mail: pmvusa@pmvusa.com
 Internet: www.pmvusa.com

PMV GmbH
 Postfach 2310
 D-41554 Kaarst
 GERMANY
 Tel: +49 (0) 2131 795 74 80
 Fax: +49 (0) 2131 795 74 99
 E-mail: info@pmv-germany.de
 Internet: www.pmv-germany.de

Palmstiernas Svenska AB
 Box 21
 S-663 21 Skoghall
 SWEDEN
 Tel: +46 (0) 54 52 14 70
 Fax: +46 (0) 54 52 14 42
 E-mail: info@palmstiernas.se
 Internet: www.palmstiernas.se

(The information in this brochure is subject to change without notice.)

