

FIGURE NUMBER INDEX

Fig No.	Page
100	
102	14
110	12
116, 116TD	20
120	13
120TD	13
150	13
151	11
180	12
200	
241	26
300	
375	8
377	8
500	
500	3
507	3
512	3
514	3
559	27
559P	27
560	19
560TD	19
563	19
578	18
578TD	18
600	
650	10
1200	
1202	14
1259	27
1300	
1303, 1303WE	42
1313, 1313WE	77
1323, 1323WE	79
1331, 1331WE	48
1341, 1341WE	77
1351, 1351WE	79
1361, 1361WE	55
1395, 1395WE	56
1400	
1414	6
1500	
1503, 1503WE	34,35,36
1513, 1513WE	77
1523, 1523WE	79
1531, 1531WE	44
1533, 1533WE	44
1541, 1541WE	77
1543, 1543WE	77
1551, 1551WE	79
1553, 1553WE	79
1561, 1561WE	51
1595, 1595WE	56
1700	
1787	22
1793	23
1797	24
1800	
1816	23
1821	5
1822	5
1823	11
1825	18

Fig No.	Page
1825TD	18
1832	82
1842	7
1847	93
1861	87
1893	25
1900	
1972	86
1973	86
1976	93
1982	92
1983	92
2000	
2002	98
2003	98
2004	99
2005	99
2006	100
2007	100
2100	
2172	101
2173	101
2300	
2309	102
2310	102
2341	94
2342	94
2345	96
2346	96
2349	97
2350	97
2375	9
2377	9
2400	
2446	90
2447	90,91
2456	84
2466	85
2467	85
2474	88
2475	88, 89
2490	83
2491	83
2494	83
2495	83
2600	
2600	16
2608	17
2612	17
2629	89
2633	95
2700	
2700	4
2712	4
2714	4
2800	
2842	7
2872	15
2900	
2920	103
2921	104
2922	103
2923	104

Fig No.	Page
3000	
3003, 3003WE	37,38,39
3013, 3013WE	77
3023, 3023WE	79
3031, 3031WE	45
3033, 3033WE	45
3041, 3041WE	77
3043, 3043WE	77
3051, 3051WE	79
3053, 3053WE	79
3061, 3061WE	52
3084, 3084WE	49
3086, 3086WE	49
3095, 3095WE	56
3400	
3460	21
3462	21
6000	
6003, 6003WE	40
6013, 6013WE	77
6023, 6023WE	79
6031, 6031WE	46
6033, 6033WE	46
6041, 6041WE	77
6043, 6043WE	77
6051, 6051WE	79
6053, 6053WE	79
6061, 6061WE	53
6084, 6084WE	50
6086, 6086WE	50
6095, 6095WE	56
9000	
9003, 9003WE	41
9013, 9013WE	77
9023, 9023WE	79
9031, 9031WE	47
9033, 9033WE	47
9041, 9041WE	77
9043, 9043WE	77
9051, 9051WE	79
9053, 9053WE	79
9061, 9061WE	54
9095, 9095WE	56
11000	
11095WE	76
11300	
11303WE	62, 63
11313WE	77
11323WE	79
11331WE	67
11331Y-WE	65
11333WE	67
11341WE	77
11343WE	77
11351WE	79
11353WE	79
11361WE	75
11365WE	73
11365Y-WE	74
11367WE	73
11384WE	71
11384Y-WE	71
11386WE	71

Fig No.	Page
16000	
16003WE	62, 63
16013WE	77
16023	79
16031WE	67
16031Y-WE	65
16033WE	67
16041WE	77
16043WE	77
16051WE	79
16053WE	79
16061WE	75
16065WE	73
16065Y-WE	74
16067WE	73
16084WE	71
16084Y-WE	69
16086WE	71
16095WE	76
19000	
19003WE	62, 63
19013WE	77
19023WE	79
19031WE	67
19031Y-WE	65
19033WE	67
19041WE	77
19043WE	77
19051WE	79
19053WE	79
19061WE	75
19065WE	73
19065Y-WE	74
19067WE	73
19084WE	71
19084Y-WE	69
19086WE	71
19095WE	76
25000	
25003, 25003WE	43
25023, 25023WE	79
12000	
120003WE	61, 62
12013WE	77
12500	
125003WE	61, 62
125013WE	77
125023WE	79
125031WE	67
125031Y-WE	65
125033WE	67
125041WE	77
125043WE	77
125051WE	79
125053WE	79
125065WE	73
125065Y-WE	74
125067WE	73
125084WE	71
125084Y-WE	69
125086WE	71
125095WE	76

POWELL BRONZES

Steam Bronze Castings

ASTM B-61

This high grade alloy is used for valves and other products recommended for higher pressures and for temperatures to 550° F.

Chemical Requirements	Minimum	Maximum
Copper, %	86.0	90.0
Tin, %	5.5	6.5
Lead, %	1.0	2.0
Zinc, %	3.0	5.0
Nickel, %	-	1.0
Iron, %	-	0.25
Phosphorus, %	-	0.05

Tensile Properties

Tensile strength, psi	34,000	-
Yield strength, psi	16,000	-
Elongation in 2", %	24	-

Composition Bronze Castings

ASTM B-62

This bronze is widely used for valves, fittings and other products for temperatures up to 450° F. It is commonly known as 85-5-5-5.

Chemical Requirements	Minimum	Maximum
Copper, %	84.0	86.0
Tin, %	4.0	6.0
Lead, %	4.0	6.0
Zinc, %	4.0	6.0
Nickel, %	-	1.0
Iron, %	-	0.30
Phosphorus, %	-	0.05

Tensile Properties

Tensile strength, psi	30,000	-
Yield strength, psi	14,000	-
Elongation in 2", %	20	-

Copper-Zinc-Silicon Alloy Rod

ASTM B-371, Alloy C69400

Alloy C69400 has excellent strength and is used mainly as a valve trim.

Chemical Requirements	Minimum	Maximum
Copper, %	80.0	83.0
Iron, %	-	0.20
Lead, %	-	.30
Silicon, %	3.5	4.5
Zinc, %	Remainder	-

Tensile Properties

Tensile strength, psi		
Up to 1 in. incl.	80,000	-
Over 1 in.	75,000	-
Yield strength, psi		
Up to 1 in. incl.	40,000	-
Over 1 in.	35,000	-
Elongation in 4 x Dia., %		
Up to 1 in. incl.	15	-
Over 1 in.	15	-

POWELL IRONS

Cast Iron

ASTM A126, Class B

Chemical Requirements	Minimum	Maximum
Sulfur, %	-	0.15
Phosphorus, %	-	0.75
Carbon, %	3.15	3.45
Manganese, %	0.65	0.75
Silicon, %	1.80	2.10

Tensile Properties

Tensile strength, psi	31,000	-
Traverse strength, pounds	3,300	-
Deflection at center, inches	0.12	-

3% Nickel Iron

3% Nickel Iron is used for corrosive services where ordinary gray iron is not adequate for the paper, pulp and petroleum industries.

Chemical Requirements	Minimum	Maximum
Carbon, %	3.00	3.50
Manganese, %	0.50	0.75
Silicon, %	1.50	2.50
Sulfur, %	0.05	0.10
Phosphorus, %	0.10	0.50
Nickel, %	3.00	4.00

Tensile Properties

Tensile strength, psi	31,000	-
-----------------------	--------	---

BRONZE GATE VALVES "U.S."

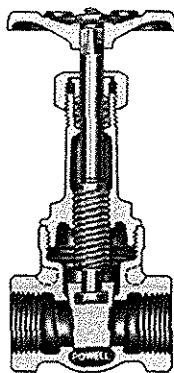

Fig. 500, 514

Inside Screw Rising Stem
Sizes, 1/4" through 3"

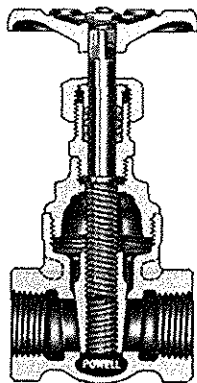

Fig. 507, 512

Inside Screw Non-rising Stem
Sizes, 1/4" through 3"

CLASS 125 and 150 SCREWED-IN BONNET THREADED ENDS

PRESSURE/TEMPERATURE RATINGS

Class 125 Fig. 500, 507

125 psi Steam at 406°F

200 psi Non-Shock Cold Water, Oil or Gas

Class 150 Fig. 512, 514

150 psi Steam at 406°F

300 psi Non-Shock Cold water, Oil or Gas

MATERIALS

DESCRIPTION	MATERIAL	ASTM Spec.
Handwheel Nut	Brass	Commercial
Identification Plate	Aluminum	Commercial
Handwheel	Malleable Iron	A-47 Gr. 32510
Stem	Silicon Bronze	B-371 C69400
Packing Gland	Brass	B-16
Packing Nut *	Bronze	B-62
Packing	Graphite Non-Asbestos	Commercial
Bonnet	Bronze	B-62
Stuffing Box **	Silicon Bronze	B-371 C69400
Body	Bronze	B-62
Wedge	Bronze	B-62

* Brass ASTM B-16 for 1/4" through 1" valves

** Furnished on Figs. 507 and 512

SPECIFICATIONS

•MSS-SP-80

FEATURES

- Renewable Solid Wedges
- Integral Seats
- High-Tensile bronze Alloy Stem

DIMENSIONS (Inches)

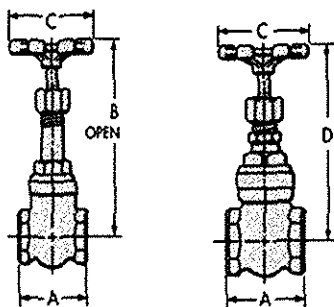

Fig. 500
Fig. 514

Fig. 507
Fig. 512

Size	1/4	3/8	1/2	3/4	1	1 1/4	1 1/2	2	2 1/2	3
A	1 3/4	2	2 3/8	2 7/16	2 3/4	3	3 3/8	3 1/2	4 1/2	5
B	4 1/4	4 1/4	4 7/8	6 1/8	7 3/8	8 5/8	9 5/8	11 11/16	14 3/4	17 1/8
C	2 1/8	2 1/8	2 1/2	2 3/4	3	3 1/4	3 5/8	4 1/16	5 1/8	5 11/16
D	3 1/2	3 1/2	3 15/16	4 9/16	5 7/16	6 1/4	6 3/4	7 13/16	9 3/8	10 3/8

WEIGHTS (pounds)

Fig. 500	0.75	0.8	1.1	1.75	2.8	3.75	5	7.2	16	22.2
Fig. 507	0.75	0.8	1.1	1.75	2.8	3.75	4.6	6.5	12.6	19.3
Fig. 512	0.7	0.7	1	1.6	2.4	3.6	4.6	6.7	13.1	20
Fig. 514	0.7	0.9	1	1.7	2.8	4	5	7.2	16	22.5

BRONZE GATE VALVES "U.S."

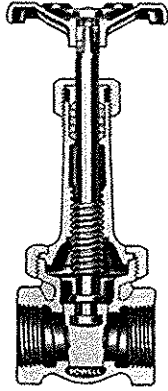

Fig. 2700, 2714
Inside Screw Rising Stem
Sizes, 1/4" through 3"

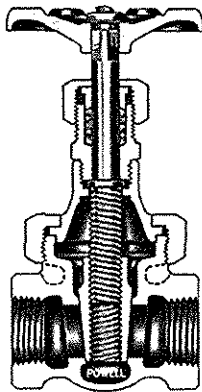

Fig. 2712
Inside screw Non-Rising Stem
Sizes, 1/4" through 3"

CLASS 125 and 150 UNION BONNET THREADED ENDS

PRESSURE/TEMPERATURE RATINGS

Class 125 Fig. 2700

125 Steam at 406°F

200 psi Non-Shock cold water, Oil or Gas

Class 150 Fig. 2712, 2714

150 Steam at 406°F

300 psi Non-Shock Cold water, Oil or Gas

MATERIALS

DESCRIPTION	MATERIAL	ASTM Spec.
Handwheel Nut	Brass	Commercial
Identification Plate	Aluminum	Commercial
Handwheel	Malleable Iron	A-47 Gr. 32510
Stem	Silicon Bronze	B-371 C69400
Packing Gland	Brass	B-16
Packing Nut *	Bronze	B-62
Packing	Graphite Non-Asbestos	Commercial
Stuffing Box ***	Silicon Bronze	B-371 C69400
Bonnet**	Bronze	b-62
Bonnet Ring	Bronze	B-62
Body	Bronze	B-62
Wedge	Bronze	B-62

* Brass ASTM B-16 for 1/4" through 1" valves

** Silicon Bronze - C69400 for 1/4", 3/8" and 1/2" valves Fig.2712

*** Furnished on Fig. 2712

SPECIFICATIONS

•MSS-SP-80

FEATURES

•Renewable Solid wedges

•Integral Seats

•High-Tensile Bronze Alloy Stem

DIMENSIONS (Inches)

Size	1/4	3/8	1/2	3/4	1	1 1/4	1 1/2	2	2 1/2	3
A	1 3/4	2	2 3/8	2 7/16	2 3/4	3	3 3/8	3 1/2	4 1/2	5
B	4 1/4	4 1/4	4 7/8	6 1/8	7 3/8	8 5/8	9 5/8	11 11/16	14 3/4	17 1/8
C	2 1/8	2 1/8	2 1/2	2 3/4	3	3 1/4	3 5/8	4 1/16	5 1/8	5 11/16
D	3 1/2	1/2	3 15/16	4 9/16	5 7/16	6 1/4	6 3/4	7 13/16	9 3/8	10 3/8

WEIGHTS (Pounds)

Fig. 2700	0.75	0.8	1.1	1.9	2.7	4	5.2	8.9	16.2	23
Fig. 2712	0.75	0.8	1.1	1.9	2.7	4	5.2	8.9	16.2	23
Fig. 2714	0.75	0.8	1.1	2	2.7	4	5.3	9.5	16.2	23.5

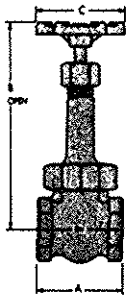

Fig. 2700
Fig. 2714

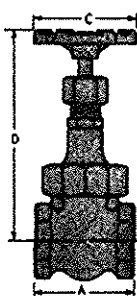

Fig. 2712

BRONZE GATE VALVES

"U.S."

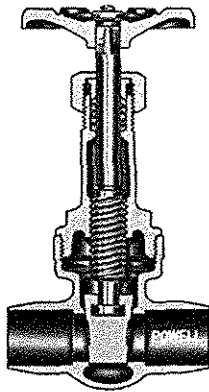

Fig. 1821
Inside Screw rising Stem
Sizes, 1/4 through 3

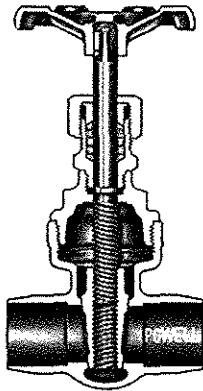

Fig. 1822
Inside Screw Non-Rising Stem
Sizes, 1/4' through 3"

CLASS 125

SCREWED-IN BONNET

SOLDER JOINT TUBING ENDS

PRESSURE/TEMPERATURE RATINGS

- 125 psi Steam at 406°F †
- 200 psi Non-Shock Cold Water, Oil or Gas

† This pressure rating applies to the valve bodies. Solder joint valves should NOT be used in services where the temperature of the fluid being handled is higher than the point at which the solder begins to soften.

MATERIALS

DESCRIPTION	MATERIAL	ASTM Spec.
Handwheel Nut	Brass	Commercial
Identification Plate	Aluminum	Commercial
Handwheel	Malleable Iron	A-47 Gr. 32510
Stem	Silicon Bronze	B-371 C69400
Packing Gland	Brass	B-16
Packing Nut *	Bronze	B-62
Packing	Graphite Non-Asbestos	Commercial
Stuffing Box **	Silicon Bronze	B-371 C69400
Bonnet	Bronze	B-62
Body	Bronze	B-62
Wedge	Bronze	B-62

*Brass ASTM B-16 for 1/4" through 1" valves

**Furnished on Fig. 1822

SPECIFICATIONS

- MSS-SP-80
- ASME B16.18

FEATURES

- Renewable Solid wedges
- Integral Seats
- High-Tensile Bronze Alloy Stem

DIMENSIONS (Inches)

Size	1/4	3/8	1/2	3/4	1	1 1/4	1 1/2	2	2 1/2	3
A	1 3/4	2 1/4	2 3/4	3 1/8	3 1/2	3 3/4	4	4 1/2	5 1/4	6
B	1/2	11/16	13/16	1	1 1/16	1 1/8	1 3/16	1 3/8	1 5/8	1 7/8
C*	.379	.504	.629	.879	1.130	1.380	1.630	2.130	2.630	3.130
G	4 1/4	4 1/4	4 7/8	6 1/8	7 3/8	8 5/8	9 5/8	11 1/16	14 3/4	17 1/8
G1	3 1/2	3 1/2	3 15/16	4 9/16	5 7/16	6 1/4	6 3/4	7 13/16	9 3/8	10 5/8
H	2 1/8	2 1/8	2 1/2	2 3/4	3	3 1/4	3 5/8	4 1/16	5 1/8	5 11/16

*Tolerance per ASME B16.18

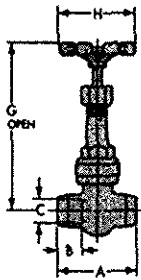

Fig. 1821

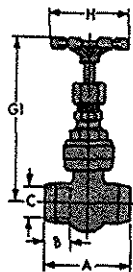

Fig. 1822

WEIGHTS (Pounds)

Fig. 1821	0.75	0.75	1.1	1.6	2.6	4.1	4.7	7.7	13.8	21.7
Fig. 1822	0.75	0.75	0.9	1.5	2.4	3.3	5.1	7.1	11.9	19.1

BRONZE O.S.&Y. GATE VALVE

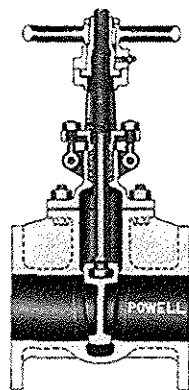

Fig. 1414

Flanged, One-Piece Bonnet Sizes, 4" and 6"

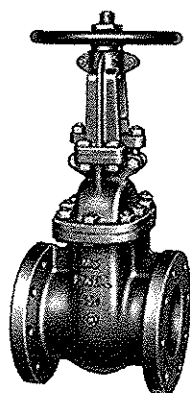

Fig. 1414

Flanged, Separable Yokearms Sizes, 8" - 16"

CLASS 150 BOLTED FLANGED YOKE-BONNET OUTSIDE SCREW RISING STEM FLANGED ENDS

PRESSURE/TEMPERATURE RATINGS

150 psi Steam at 406°F

225 psi Non-Shock Cold Water, Oil or Gas

MATERIALS

DESCRIPTION	MATERIAL	ASTM Spec.
Stem Bushing Nut	Malleable Iron	A-47, Grade 32510
Handwheel Key	Steel	A-108, Grade 1020
Handwheel	Malleable Iron	A-47, Grade 32510
Cap Screws	Steel	A-449
Bearing Cap	Malleable Iron	A-47, Grade 32510
Yokearm Ear Bolts & Nuts (8"-16")	Steel	A-307, Grade B
Yokearm Bolts & Nuts(8"-16")	Steel	A-307, Grade B
Stem Bushing	Bronze	B-62
Bonnet	Bronze	B-62
Eyebolts	Stainless Steel	300 Series
Eyebolts Nut, & Pins	Stainless Steel	300 Series
Gland	Bronze	B-62
Packing	Non-Asbestos	Commercial
Body Nuts	Brass	B-16
Body Bolts	Steel	A-307, Grade B
Gasket	Compressed Non-Asbestos	Commercial
Stem	Brass	B-16
Wedge	Bronze	B-62
Body	Bronze	B-62
Lubricant Fitting	Steel	Commercial
Yokearms (8"-16")	Malleable Iron	A-47, Grade 32510

SPECIFICATIONS

- Flanged End valves have dimensions in accordance with ASME B16.24

FEATURES

- Renewable Solid Wedges
- Integral Seats
- High- Tensile Brass stems
- Large stuffing box

DIMENSIONS (Inches)

Size	4	6	8	10	12	14	16
O	9	10 1/2	11 1/2	13	14	15	16
A	20 1/4	30	37 3/8	48 1/4	57 7/8	64	74 3/8
V	9	12	14	17	18	22	22

WEIGHTS (Pounds)

Fig. 1414	80	157	255	475	560
-----------	----	-----	-----	-----	-----

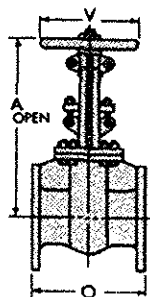

Fig. 1414

BRONZE GATE VALVES

"WHITE STAR"

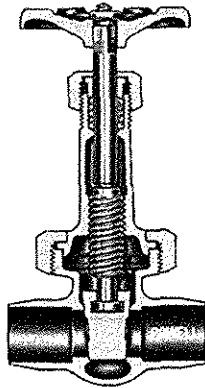

Fig. 1842
Solder Joint Tubing Ends
Inside Screw Rising Stem
Sizes, 1/4" through 3"

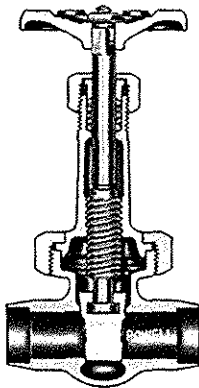

Fig. 2842
Silver Braze Tubing Ends
Inside Screw Rising Stem
Sizes, 1/4" through 3"

CLASS 200

UNION BONNET

SOLDER JOINT and

SILVER BRAZE TUBING ENDS

PRESSURE/TEMPERATURE RATINGS

200 psi Steam at 550°F †

400 psi Non-Shock Cold Water, Oil or Gas

† This pressure rating applies to the valve bodies. Solder joint valves should NOT be used in services where the temperature of the fluid being handled is higher than the point at which the solder begins to soften.

MATERIALS

DESCRIPTION	MATERIAL	ASTM Spec.
Handwheel Nut	Brass	Commercial
Identification Plate	Aluminum	Commercial
Handwheel	Malleable Iron	A-47 Gr.32510
Stem	Silicon Bronze	B-371 C69400
Packing Gland	Brass	B16
Packing Nut *	Bronze	B-62
Packing	Graphite Non-Asbestos	Commercial
Bonnet	Bronze	B-61
Bonnet Ring	Bronze	B-61
Body	Bronze	B-61
Wedge	Bronze	B-61

*Brass ASTM B-16 for 1/4" through 1" valves

SPECIFICATIONS

- MSS SP-80
- MSS SP-73
- ASME B16.18

FEATURES

- Renewable Solid Wedges
- High-Tensile Bronze Alloy Stems
- Integral Seats

DIMENSIONS (Inches)

Size	1/4	3/8	1/2	3/4	1	1 1/4	1 1/2	2	2 1/2	3
A(Fig.1842)S.J.T.	1 3/4	2 1/4	2 3/4	3 1/8	3 1/2	3 3/4	4	4 1/2	4 1/2	6
(Fig.2842)S.B.T	1 3/4	2 1/4	2 1/2	3	3 1/4	3 1/2	4	4 1/2	5 1/4	6
B(Fig.1842)S.J.T.	1/2	11/16	13/16	1	1 1/16	1 1/8	1 3/16	1 3/8	1 5/8	1 7/8
(Fig.2842)S.B.T.	17/64	5/16	3/8	13/32	7/16	1/2	5/8	21/32	25/32	53/64
C*	.379	.504	.629	.879	1.130	1.380	1.630	2.130	2.630	3.130
G	4 1/4	4 1/4	4 7/8	6 1/8	7 3/8	8 5/8	9 5/8	11 1/16	15 1/8	17 7/16
H	2 1/8	2 1/8	2 1/2	2 3/4	3	3 1/4	3 5/8	4 1/16	5 11/16	6 3/8

*Tolerance per ASME B16.18

WEIGHT (Pounds)

Fig.1842	0.8	0.9	1.1	1.9	2.6	5	6.5	8.2	17.6	24.3
Fig.2842	0.8	0.9	1.1	1.9	2.6	5	6.5	8.2	17.6	24.3

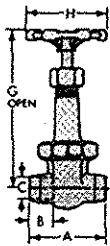

Fig. 1842

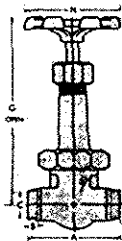

Fig. 2842

BRONZE GATE VALVES

"WHITE STAR"

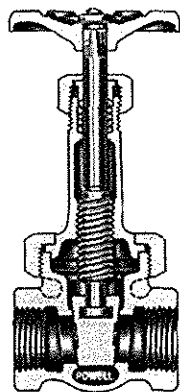

Fig. 375
Fig. 377
Inside Screw Rising Stem
Sizes, 1/4" through 3"

CLASS 200 and 300

UNION BONNET

THREADED ENDS

PRESSURE/TEMPERATURE RATINGS

Class 200 Fig. 375

200 psi Steam at 550°F

400 psi Non-Shock Cold Water, Oil or Gas

Class 300 Fig. 377

300 psi Steam at 550°F

1/4" - 2" 1000 psi Non-Shock Cold Water, Oil or Gas

2 1/2" - 3" 600 psi Non-Shock Cold Water, Oil or Gas

MATERIALS

DESCRIPTIONS	MATERIAL	ASTM Spec.
Handwheel Nut	Brass	Commercial
Identification Plate	Aluminum	Commercial
Handwheel	Malleable Iron	A-47 Gr. 32510
Stem	Silicon Bronze	B-371 C69400
Packing Gland	Brass	B-16
Packing Nut *	Bronze	B-62
Packing	Graphite Non-Asbestos	Commercial
Bonnet	Bronze	B-61
Bonnet Ring	Bronze	B-61
Body	Bronze	B-61
Wedge	Bronze	B-61

*Brass ASTM B-16 for 1/4" through 1" valves

SPECIFICATIONS

•MSS-SP-80

FEATURES

- Renewable Solid Wedges
- Integral Seats
- High-Tensile Bronze Alloy Stem

DIMENSIONS (Inches) Figs. 375

Size	1/4	3/8	1/2	3/4	1	1 1/4	1 1/2	2	2 1/2	3
A	1 13/16	2 1/16	2 7/16	2 9/16	2 15/16	3 1/8	3 1/2	4	4 5/8	5 1/8
B	4 1/4	4 1/4	4 7/8	6 1/8	7 3/8	8 5/8	9 5/8	11 11/16	15 1/8	17 7/16
C	2 1/8	2 1/8	2 1/2	2 3/4	3	3 1/4	3 5/8	4 1/16	4 3/4	5 11/16

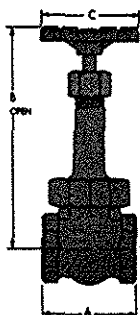

Fig. 375
Fig. 377

DIMENSIONS (Inches) Figs 377

Size	1/4	3/8	1/2	3/4	1	1 1/4	1 1/2	2	2 1/2	3
A	1 15/16	2 1/8	2 7/16	2 11/16	3	3 3/8	3 3/4	4 3/8	5	5 5/8
B	4 7/8	4 7/8	5 7/8	7 3/16	8 1/4	9 1/2	10 3/4	13 1/8	14 1/16	16 3/8
C	3	3	3 1/4	3 5/8	4 1/8	4 5/8	5 1/8	5 11/16	8	9

WEIGHTS (Pounds)

Fig.375	0.8	0.9	1.2	2	2.7	4.7	5.5	9.1	18.9	25.8
Fig.377	1.3	1.3	1.8	3	4.9	6.9	8.9	16.7	23.9	32.4

BRONZE GATE VALVES

WITH ROLLED-IN SEAT RINGS

"WHITE STAR"

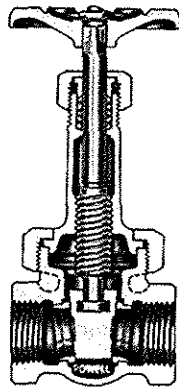

Fig. 2375
Class 200
Inside Screw Rising Stem
Sizes, 3/8" through 3"

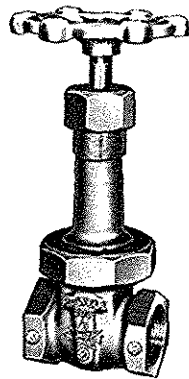

Fig. 2377
Class 300
Inside Screw Rising Stem
Sizes, 3/8" through 3"

CLASS 200 and 300

UNION BONNET

THREADED ENDS

PRESSURE/TEMPERATURE RATINGS

Class 200 Fig. 2375

200 psi Steam at 550°F

400 psi Non-Shock cold water, Oil or Gas

Class 300 Fig. 2377

300 psi steam at 550°F

3/8" - 2" 1000 psi Non-Shock Cold Water, Oil or Gas

2 1/2" & 3" 600 psi Non-Shock Cold Water, Oil or Gas

MATERIALS

DESCRIPTION	MATERIAL	ASTM Spec.
Handwheel Nut	Brass	Commercial
Identification Plate	Aluminum	Commercial
Handwheel	Malleable Iron	A-47 Gr. 32510
Stem	Silicon Bronze	B-371 C69400
Packing Nut *	Bronze	B-62
Packing Gland	Brass	B-16
Packing	Graphite Non-Asbestos	Commercial
Collar**	Brass	B-16
Bonnet	Bronze	B-61
Bonnet Ring	Bronze	B-61
Body	Bronze	B-61
Wedge	Bronze	B-61
Seat Ring	Stainless Steel	***A-312, Type 304

* Brass ASTM B-16 for valve sizes 3/8" through 1" valves

** Sizes 3/8 - 1/2" inclusive (Fig. 2377)

*** Sizes 3/8 - 1/2" A-276, Type 410

SPECIFICATIONS

•MSS-SP-80

FEATURES

•Renewable Solid Wedges

•Rolled-in Seat Rings

•High-Tensile Bronze Alloy Stems

DIMENSIONS (Inches) Fig. 2375

Size	3/8	1/2	3/4	1	1 1/4	1 1/2	2	2 1/2	3
A	2 1/16	2 5/16	2 9/16	2 15/16	3 1/8	3 1/2	4	4 5/8	5 1/8
B	4 1/4	4 7/8	6 1/8	7 3/8	8 5/8	9 5/8	11 11/16	15 1/8	17 7/16
E	2 1/8	2 1/2	2 3/4	3	3 1/4	3 5/8	4 1/16	5 11/16	6 3/8

DIMENSIONS (Inches) Fig. 2377

Size	3/8	1/2	3/4	1	1 1/4	1 1/2	2	2 1/2	3
A	2 1/8	2 7/16	2 11/16	3	3 3/8	3 3/4	4 3/8	5	5 5/8
B	4 7/8	5 7/8	7 3/16	8 1/4	9 1/2	10 3/4	13 1/8	14 1/16	16 3/8
E	3	3 1/4	3 5/8	4 1/8	4 5/8	5 1/8	5 11/16	8	9

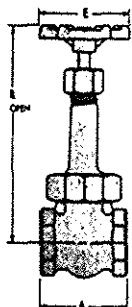

Fig. 2375
Fig. 2377

WEIGHTS (Pounds)

Fig.2375	0.9	1.2	1.9	2.8	5	5.4	8.9	18.7	25.9
Fig.2377	1.3	1.7	2.9	4.2	6.5	9.5	16.7	22.6	31.7

BRONZE GLOBE VALVES

"CRESCENT"

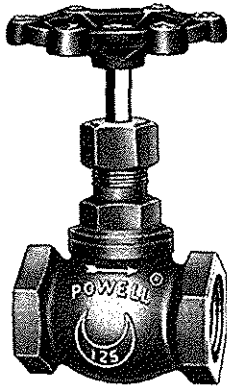

Fig. 650
Globe, threaded
Sizes, 1/4" through 3"

CLASS 125

SCREWED-IN BONNET

THREADED ENDS

PRESSURE/TEMPERATURE RATINGS

125 psi Steam at 406°F

200 psi Non-Shock cold water, Oil or Gas

MATERIALS

DESCRIPTIONS	MATERIAL	ASTM Spec.
Handwheel Nut	Brass	Commercial
Identification Plate	Aluminum	Commercial
Handwheel	Malleable Iron	A-47 Gr. 32510
Stem	Silicon Bronze	B-371 C69400
Packing Nut **	Bronze	B-62
Packing	Graphite Non-Asbestos	Commercial
Bonnet†	Bronze	B-62
Disc Locknut	Silicon Bronze	B-371 C69400
Disc	Bronze	B-62
Body	Bronze	B-62
Horseshoe Ring *	Stainless Steel	A-582, Type 303

† Sizes 1/4" to 3/4" Brass ASTM B-16

* 3/4" Alternate material A-167 Type 304

** Brass ASTM B-16 for Valve Sizes 1/4" through 1 1/4" incl.

SPECIFICATIONS

•MSS-SP-80

FEATURES

•High-Tensile Bronze Alloy Stems

•Integral Seats

•Discs in 3/4" and larger valves are attached to stem by disc locknut. The 1/2" and smaller valves have stem and disc integral

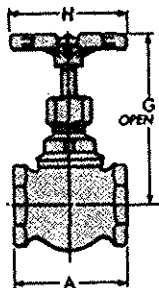

Fig. 650

DIMENSIONS (Inches)

Size	1/4	3/8	1/2	3/4	1	1 1/4	1 1/2	2	2 1/2	3
A	1 5/8	1 15/16	2 1/8	2 1/2	3	3 7/16	3 13/16	4 3/4	5 11/16	6 9/16
G	2 11/16	3	3 3/8	3 15/16	4 3/8	5 1/16	5 3/8	6 1/2	7 5/16	8 1/4
H	2 1/8	2 1/2	2 3/4	3	3 1/4	3 5/8	4 1/8	4 3/4	5 1/8	5 3/4

WEIGHTS (Pounds)

Fig. 650	0.4	0.6	0.8	1.3	1.9	2.7	4.4	5.9	10.1	15.4
----------	-----	-----	-----	-----	-----	-----	-----	-----	------	------

BRONZE GLOBE and ANGLE VALVES "UNION"

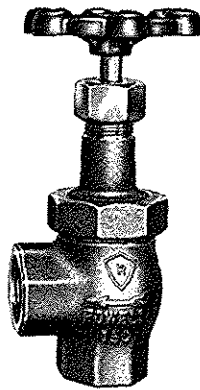

Fig. 151
Angle, Threaded
Sizes, 1/4" through 3"
Fig. 150
Globe, Threaded
Sizes, 1/4" through 3"

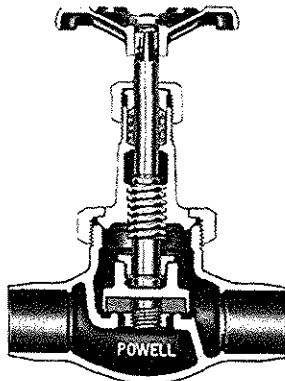

Fig. 1823
Globe, Solder Joint Ends
Sizes, 1/2" through 2"

CLASS 150 UNION BONNET RENEWABLE COMPOSITION DISC THREADED and SOLDER JOINT ENDS

PRESSURE/TEMPERATURE RATINGS

150 psi Steam † at 406°F

300 psi Non-Shock cold Water, Oil or Gas

† This pressure rating applies to the solder joint end valve bodies. Solder joint valves should NOT be used in services where the temperature of the fluid being handled is higher than the point at which the solder begins to soften.

MATERIALS

DESCRIPTIONS	MATERIAL	ASTM Spec.
Handwheel Nut	Brass	Commercial
Identification Plate	Aluminum	Commercial
Handwheel	Malleable Iron	A-47 Gr. 32510
Stem	Silicon Bronze	B-371 C69400
Packing Nut *	Bronze	B-62
Packing Gland	Brass	B-16
Packing	Graphite Non-Asbestos	Commercial
Bonnet	Bronze	B-62
Bonnet Ring	Bronze	B-62
Disc Locknut**	Silicon Bronze	B-371 C69400
Horseshoe Ring **	Stainless Steel	A-582, Type 303
Disc Holder	Bronze	B-62
Disc	Glass Filled PTFE	Commercial
Disc Nut	Bronze	B-62
Body	Bronze	B-62

* Silicon bronze B-371 C69400 Sizes 1/4" to 1" incl.

**Sizes 1/4" to 2" incl.

SPECIFICATIONS

•MSS-SP-80

•ASME B16.18

FEATURES

•Integral Seats have opening equal to nominal pipe size of valve

•High-Tensile bronze Alloy Stems

DIMENSIONS (Inches)

Size	1/4	3/8	1/2	3/4	1	1 1/4	1 1/2	2	2 1/2	3
A (Fig.150)	2 1/8	2 1/4	2 1/2	3	3 9/16	4 1/8	4 5/8	5 3/4	6 5/8	8 1/2
A(Fig.1823)	-	-	3 3/4	4 7/16	4 15/16	5 1/2	6	7 1/4	-	-
B(Fig.151)	1 1/16	1 1/8	1 1/4	1 1/2	1 3/4	2 1/16	2 5/16	2 7/8	3 1/4	4 1/4
C	-	-	13/16	1	1 1/16	1 1/8	1 3/16	1 3/8	-	-
D*	-	-	.629	.879	1.130	1.380	1.630	2.130	-	-
G	4 3/16	4 3/16	4 13/16	5 7/16	6 1/8	6 13/16	7 11/32	8 1/8	9 1/2	10 13/16
H	2 1/2	2 1/2	2 3/4	3	3 1/4	3 5/8	4 1/16	4 5/8	5 11/16	6 3/8

*Tolerance per ASME B16.18

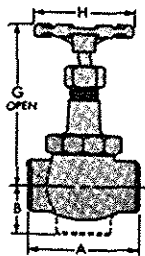

Fig. 150
Fig. 151

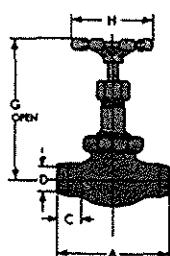

Fig. 1823

WEIGHTS (Pounds)

Fig. 150	0.8	0.9	1.3	2.1	3.4	5.1	6.6	10.5	18.6	28.4
Fig. 151	0.8	0.9	1.3	2.1	3.3	4.9	6.8	11.8	19	29
Fig.1823	-	-	1.4	2.3	3.3	4.6	6.4	10.9	-	-

BRONZE REGRINDING GLOBE and GLOBE NEEDLE VALVES

"MODEL STAR"

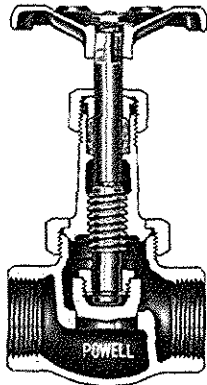

Fig. 110
Globe, Threaded
Sizes, 1/4" through 3"

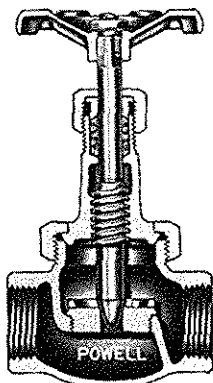

Fig. 180
Globe Needle, Threaded
Sizes, 1/4" through 1"

CLASS 200 UNION BONNET THREADED ENDS

PRESSURE/TEMPERATURE RATINGS

200 psi Steam at 550°F

400 psi Non-Shock Cold water, Oil or Gas

MATERIALS

DESCRIPTIONS	MATERIAL	ASTM Spec.
Handwheel Nut	Brass	Commercial
Identification Plate	Aluminum	Commercial
Handwheel	Maileable Iron	A-47 Gr. 32510
Stem	Silicon Bronze	B-371 C69400
Packing Nut **	Bronze	B-62
Packing Gland	Brass	B-16
Packing Graphite Non-Asbestos	Commercial	
Bonnet	Bronze	B-61
Bonnet Ring	Bronze	B-61
Disc Locknut***	Silicon Bronze	B-371 C69400
Horseshoe Ring***	Stainless Steel	A-582, Type 303
Disc****	Bronze	B-61
Body	Bronze	B-61
Seat Ring*	Silicon Bronze	B-371 C69400

* Fig. 180 1/2" to 1" size

** Silicon Bronze B-371 C69400 Sizes 1/4" to 1" incl.

*** Sizes 1/4" to 2" incl.

**** Sizes 1/4" - 1 1/4" incl. Silicon Bronze B-371 C69400

SPECIFICATIONS

•MSS-SP-80

FEATURES

- Plug type Discs are held by a locknut (Fig. 110)
- Disc and Stem are one piece in Needle valves (Fig. 180)
- Integral Seats have openings equal to nominal pipe size of the valve
- Needle valves have renewable Seat Rings (in sizes 1/2" to 1")
- High-Tensile Bronze Alloy Stems
- Valves can be reground without being removed from the line

DIMENSIONS (Inches)

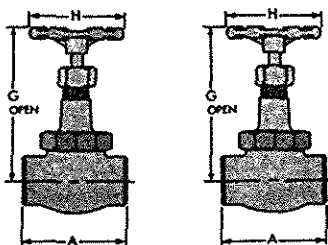

Fig. 110

Fig. 180

Size	1/4	3/8	1/2	3/4	1	1 1/4	1 1/2	2	2 1/2	3
A(Fig.110)	2 1/8	2 1/4	2 1/2	3	3 9/16	4 1/8	4 5/8	5 3/4	6 1/2	7 1/4
A(Fig.180)	2	2 1/8	2 1/2	3	3 9/16	-	-	-	-	-
G(Fig.110)	4 1/32	4 1/32	4 11/16	5 9/16	6 7/32	6 25/32	7 23/32	8 3/4	9 7/16	10 3/4
G(Fig.180)	3 13/16	3 13/16	4 5/8	5 1/2	6 5/32	-	-	-	-	-
H	2 1/2	2 1/2	2 3/4	3 1/4	3 5/8	4 1/16	4 3/4	5 11/16	5 11/16	6 3/8
Diameter of Orifice (Fig.180)	1/8	3/16	1/4	3/8	1/2	-	-	-	-	-

WEIGHTS (Pounds)

Fig.110	0.9	0.9	1.3	2.2	3.4	4.9	7.7	12.3	16.3	24.1
Fig.180	0.9	0.9	1.3	2.1	3.3	-	-	-	-	-

BRONZE REGRINDING GLOBE VALVES "MODEL STAR"

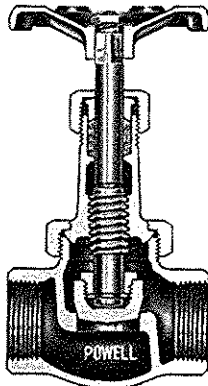

Fig. 120
Globe, Threaded
Sizes, 1/4" through 3"

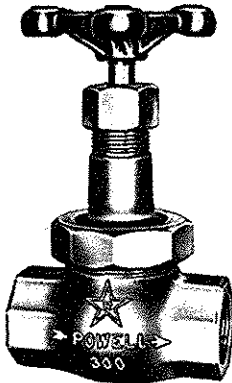

Fig. 120TD
Soft Seat (1)
Sizes, 1/4" through 3"
(1) Recommended Maximum Temperature
For PTFE Seat is 450°F

CLASS 300 UNION BONNET THREADED ENDS

PRESSURE/TEMPERATURE RATINGS

300 psi Steam at 550°F
1/4" - 2" 1000 psi Non-Shock Cold Water, Oil or Gas
2 1/2" & 3" 600 psi Non-Shock Cold Water, Oil or Gas

MATERIALS

DESCRIPTIONS	MATERIAL	ASTM Spec.
Handwheel Nut	Brass	Commercial
Identification Plate	Aluminum	Commercial
Handwheel	Malleable Iron	A-47 Gr. 32510
Stem	Silicon Bronze	B-371 C69400
Packing Nut **	Bronze	B-62
Packing Gland	Brass	B-16
Packing	Graphite Non-Asbestos	Commercial
Bonnet	Bronze	B-61
Bonnet Ring	Bronze	B-61
Disc Locknut*	Silicon Bronze	B-371 C69400
Horseshoe Ring*	Stainless Steel	A-582, Type 303
Disc**	Bronze	B-61
Body	Bronze	B-61
Disc Insert ***	PTFE	Commercial

* Sizes 1/4" to 2" incl.

** Sizes 1/4" to 1" Silicon Bronze B-371 C69400

*** Fig. 120TD

SPECIFICATIONS

•MSS-SP-80

FEATURES

- Plug type Discs are held by a locknut
- High-Tensile Bronze Alloy Stems
- Valves can be reground without being removed from the line

DIMENSIONS (Inches)

Size	1/4	3/8	1/2	3/4	1	1 1/4	1 1/2	2	2 1/2	3
A	2 1/4	2 3/8	2 5/8	3 1/4	3 13/16	4 3/8	4 7/8	6	7	7 7/8
G	4 1/32	4 1/32	4 5/8	5 1/2	6 7/32	6 3/4	7 23/32	8 11/16	10 7/8	12 1/8
H	2 1/2	2 1/2	2 3/4	3 1/4	3 5/8	4 1/16	4 3/4	5 11/16	8	9

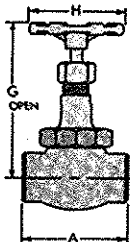

Fig. 120

WEIGHTS (Pounds)

Fig.120	0.9	1	1.5	2.7	3.9	5.7	8.8	13.9	22.5	36.3
---------	-----	---	-----	-----	-----	-----	-----	------	------	------

BRONZE GLOBE VALVES

"WHITE STAR"

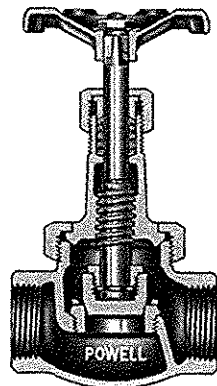

Fig. 102
Class 200 Globe, Threaded
Sizes, 1/4" through 3"

Fig 1202
Class 300 Globe, Threaded
Sizes, 1/4" through 3"

CLASS 200 and 300

UNION BONNET

RENEWABLE SEAT and DISC

THREADED ENDS

PRESSURE/TEMPERATURE RATINGS

Class 200 Fig. 102

200 psi Steam at 550°F

400 psi Non-Shock Cold Water Oil or Gas

Class 300 Fig. 1202

300 psi Steam at 550°F

1/4" - 2" 1000 psi Non-Shock Cold Water, Oil or Gas

2 1/2" & 3" 600 psi Non-Shock Cold Water, Oil or Gas

MATERIALS

DESCRIPTIONS	MATERIAL	ASTM Spec.
Handwheel Nut	Brass	Commercial
Identification Plate	Aluminum	Commercial
Handwheel	Malleable Iron	A-47 Gr. 32510
Stem	Silicon Bronze	B-371 C69400
Packing Nut **	Bronze	B-62
Packing Gland	Brass	B-16
Packing	Graphite Non-Asbestos	Commercial
Bonnet	Bronze	B-61
Bonnet Ring	Bronze	B-61
Disc Locknut***	Silicon Bronze	B-371 C69400
Horseshoe Ring***	Stainless Steel	A-582, Type 303
Disc*	Bronze	B-61
Seat Ring	Bronze	B-61
Body	Bronze	B-61

* Sizes 1/4" to 1 1/4" incl. Silicon Bronze B-371 C69400

** Sizes 1/4" to 1" incl. Silicon Bronze B-371 C69400

*** Sizes 1/4" to 2" incl.

SPECIFICATIONS

•MSS-SP-80

DIMENSIONS (Inches) Fig. 102

Size	1/4	3/8	1/2	3/4	1	1 1/4	1 1/2	2	2 1/2	3
A	2 1/8	2 1/4	2 1/2	3	3 9/16	4 1/8	4 5/8	5 3/4	6 5/8	8 1/2
G	4 1/32	4 1/32	4 5/8	5 1/2	6 5/32	6 11/16	7 21/32	8 5/8	9 1/2	10 7/8
H	2 1/2	2 1/2	2 3/4	3 1/4	3 5/8	4 1/16	4 3/4	5 11/16	5 11/16	6 3/8

DIMENSIONS (Inches) Fig. 1202

Size	1/4	3/8	1/2	3/4	1	1 1/4	1 1/2	2	2 1/2	3
A	2 1/4	2 3/8	2 5/8	3 1/4	3 13/16	4 3/8	4 7/8	6	7 1/2	8 3/4
G	4 1/32	4 1/32	4 5/8	5 1/2	5 7/8	6 3/4	7 23/32	8 23/32	10 11/16	12 1/16
H	2 1/2	2 1/2	2 3/4	3 1/4	3 5/8	4 1/16	4 3/4	5 11/16	8	9

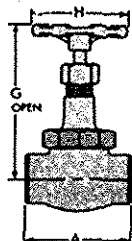

Fig. 102
Fig. 1202

WEIGHTS (Pounds)

Fig.102	0.9	1	1.4	2.3	3.4	5	7.9	12.6	20.2	30.3
Fig.1202	1.1	1.1	1.5	2.5	4.1	5.8	8.9	14.4	26.5	42

BRONZE GLOBE VALVES

"WHITE STAR"

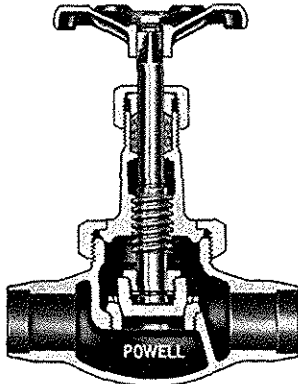

Fig. 2872
Silver Braze Ends
Sizes, 1/4" through 2"

CLASS 200

UNION BONNET RENEWABLE SEAT and DISC SILVER BRAZE TUBING ENDS

PRESSURE/TEMPERATURE RATINGS

200 psi Steam at 550°F

400 psi Non-Shock Cold Water, Oil or Gas

MATERIALS

DESCRIPTION	MATERIAL	ASTM Spec.
Handwheel Nut	Brass	Commercial
Identification Plate	Aluminum	Commercial
Handwheel	Malleable Iron	A-47 Gr. 32510
Stem	Silicon Bronze	B-371 C69400
Packing Nut *	Bronze	B-62
Packing Gland	Brass	B-16
Packing	Graphite Non-Asbestos	Commercial
Bonnet	Bronze	B-61
Bonnet Ring	Bronze	B-61
Disc Locknut ***	Silicon Bronze	B-371 C69400
Horseshoe Ring ***	Stainless Steel	A-582, Type 303
Disc **	Bronze	B-61
Seat Ring	Bronze	B-61

* Sizes 1/4" to 1" incl. Silicon Bronze B-371 C69400

** Sizes 1/4" to 1 1/4" incl. Silicon Bronze B-371 C69400

*** Sizes 1/4" to 2" incl.

SPECIFICATIONS

*MSS SP-80

*MSS SP-73

FEATURES

*Renewable Plug type Discs are held by a locknut

*Renewable Screwed-in Seat Rings

*High-Tensile Bronze Alloy Stems

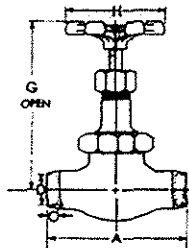

Fig. 2872

DIMENSIONS (Inches)

Size	1/4	3/8	1/2	3/4	1	1 1/4	1 1/2	2
A	2 1/2	3	3 1/4	3 3/4	4 1/4	5	5 1/4	6 1/2
C	17/64	5/16	3/8	13/32	7/16	1/2	5/8	21/32
D *	.379	.504	.629	.879	1.130	1.380	1.630	2.130
G	4 1/32	4 1/32	4 5/8	5 15/32	6 5/32	6 11/16	7 21/32	8 5/8
H	2 1/2	2 1/2	2 3/4	3 1/4	3 5/8	4 1/16	4 3/4	5 11/16

*Tolerance per ASME B16.18

WEIGHTS (Pounds)

Fig.2872	0.9	1.1	1.4	2.4	3.5	5.3	7.6	12
----------	-----	-----	-----	-----	-----	-----	-----	----

**BRONZE (FULL FLOW)
GLOBE VALVES
"W.S."**

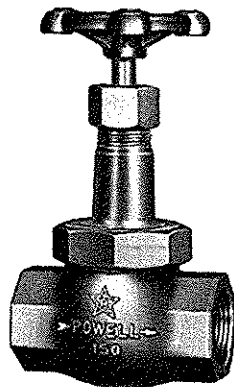
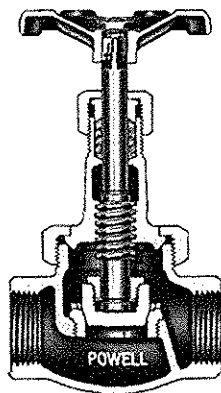

Fig. 2600
Globe threaded
Sizes 1/4 through 2"

**CLASS 150
UNION BONNET RENEWABLE
STAINLESS STEEL SEAT and DISC
THREADED ENDS**

PRESSURE/TEMPERATURE RATINGS

150 psi Steam at 406°F

300 psi Non-shock cold water, Oil or Gas

MATERIALS

DESCRIPTION	MATERIAL	ASTM Spec.
Handwheel Nut	Brass	Commercial
Identification Plate	Aluminum	Commercial
Handwheel	Malleable Iron	A-47 Gr.32510
Stem	Silicon Bronze	B-371 C69400
Packing Nut*	Bronze	B-62
Packing Gland	Brass	B-16
Packing	Graphite Non-Asbestos	Commercial
Bonnet	Bronze	B-62
Bonnet Ring	Bronze	B-62
Disc Locknut	Silicon Bronze	B-371 C69400
Horseshoe Ring	Stainless Steel	A-582, Type 303
Disc	Stainless Steel	A-582, Type 416
Seat Ring	Stainless Steel	A-582, Type 416
Body	Bronze	B-62

*Sizes 1/4" to 1" incl. Brass ASTM B-16

SPECIFICATIONS

•MSS SP-80

FEATURES

- Renewable Plug Type Stainless Steel Disc
- Renewable Stainless Steel seat has full nominal pipe size opening
- High-Tensile Bronze Alloy Stems
- Differential hardness between seat and disc to prevent galling

DIMENSIONS (Inches)

Size	1/4	3/8	1/2	3/4	1	1 1/4	1 1/2	2
A	2 1/8	2 1/4	2 1/2	3	3 9/16	4 1/8	4 5/8	5 3/4
G	4 1/32	4 1/32	4 19/32	5 1/8	5 13/16	6 1/2	7 5/32	8 1/16
H	2 1/2	2 1/2	2 3/4	3	3 1/4	3 5/8	4 1/16	4 3/4

WEIGHTS (Pounds)

Fig.2600	0.9	0.9	1.3	2	3.3	4.9	6.5	11
----------	-----	-----	-----	---	-----	-----	-----	----

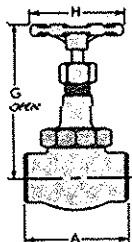

Fig. 2600

BRONZE (FULL FLOW) GLOBE VALVES "W.S."

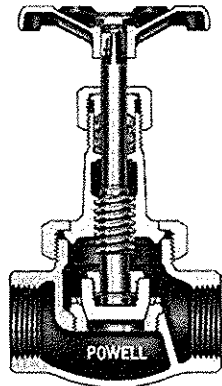

Fig. 2608
Class 200 Globe, Threaded
Sizes, 1/4" through 3"

Fig. 2612
Class 300 Globe, Threaded
Sizes, 1/4" through 3"

CLASS 200 and 300 UNION BONNET RENEWABLE STAINLESS STEEL SEAT and DISC THREADED ENDS

PRESSURE/TEMPERATURE RATINGS

Class 200 Fig. 2608

200 psi Steam at 550°F

400 psi Non-Shock Cold water, Oil or Gas

Class 300 Fig. 2612

300 psi Steam at 550°F

1/4"-2" 1000 psi Non-Shock Cold Water, Oil or Gas

2 1/2"-3" 600 psi Non-Shock Cold Water, Oil or Gas

MATERIALS

DESCRIPTION	MATERIAL	ASTM Spec.
Handwheel	Brass	Commercial
Identification Plate	Aluminum	Commercial
Handwheel	Malleable Iron	A-47 Gr. 32510
Stem	Silicon Bronze	B-371 C69400
Packing Nut*	Bronze	B-62
Packing Gland	Brass	B-16
Packing	Graphite Non-Asbestos	Commercial
Bonnet	Bronze	B-61
Bonnet Ring	Bronze	B-61
Disc Locknut***	Silicon Bronze	B-371 C69400
Horse Shoe Ring***	Stainless Steel	A582, Type 303
Disc	Stainless Steel	A582, Type 416
Seat Ring	Stainless Steel	A582, Type 416
Body	Bronze	B-61
Stud**	Steel	A-193, Grade B7
Stud Nut**	Brass	Commercial
Gasket**	Compressed Non-Asbestos	Commercial

* Brass ASTM B-16 for 1/4" through 1" valves

** 2 1/2" and 3" valves have bolted bonnets

*** Sizes 1/4" to 2" incl.

SPECIFICATIONS

*MSS SP-80

FEATURES

- Renewable Plug Type Stainless Steel Disc
- Renewable Stainless Steel seat has full nominal pipe size opening
- High-Tensile Bronze Alloy Stems
- Differential hardness between seat and disc to prevent galling

DIMENSIONS (Inches) Fig. 2608

Size	1/4	3/8	1/2	3/4	1	1 1/4	1 1/2	2	2 1/2	3
A	2 1/8	2 1/4	2 1/2	3	3 9/16	4 1/8	4 5/8	5 3/4	6 5/8	8 1/2
G	4 1/32	4 1/32	4 5/8	5 1/2	6 5/32	6 11/16	7 21/32	8 5/8	10 13/16	11 15/16
H	2 1/2	2 1/2	2 3/4	3 1/4	3 5/8	4 1/16	4 3/4	5 11/16	7	8

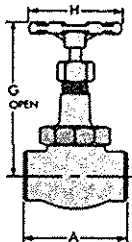

Fig. 2608
Fig. 2612

DIMENSIONS (Inches) Fig. 2612

Size	1/4	3/8	1/2	3/4	1	1 1/4	1 1/2	2	2 1/2	3
A	2 1/4	2 3/8	2 5/8	3 1/4	3 13/16	4 3/8	4 7/8	6	7 1/4	8 3/4
G	4 1/32	4 1/32	4 5/8	5 1/2	6 7/32	6 3/4	7 23/32	8 11/16	11 1/4	13 1/8
H	2 1/2	2 1/2	2 3/4	3 1/4	3 5/8	4 1/16	4 3/4	5 11/16	8	9

WEIGHTS (Pounds)

Fig. 2608	0.9	0.9	1.4	2.4	3.3	4.9	7.7	12.4	26.6	36.6
Fig. 2612	0.9	1.1	1.4	2.4	4	5.7	8.7	14.4	37.7	58.5

BRONZE SWING CHECK VALVES

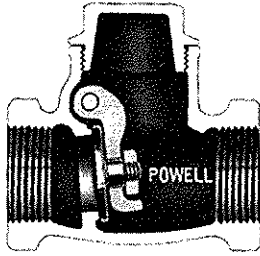

Fig. 578
Threaded
Sizes, 1/4" through 3"
Fig. 578TD
Soft seat
Sizes, 1/4" through 3"

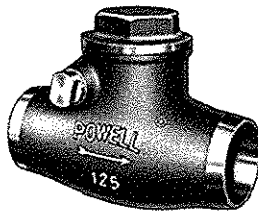

Fig. 1825
Solder Joint
Sizes, 1/2" through 3"
Fig. 1825TD
Soft seat
Sizes, 1/2" through 3"

CLASS 125 SCREWED-IN CAP THREADED and SOLDER JOINT TUBING ENDS

PRESSURE/TEMPERATURE RATINGS

125 psi Steam † at 406°F

200 psi Non-Shock Cold Water, Oil or Gas

† This pressure rating applies to the solder joint end valve bodies. Solder joint valves should NOT be used in services where the temperature of the fluid being handled is higher than the point at which the solder begins to soften.

MATERIALS

DESCRIPTION	MATERIAL	ASTM Spec.
Side Plug	Brass	B-16
Cap *	Bronze	B-62
Body	Bronze	B-62
Carrier Pin	Brass	B-16
Carrier	Bronze	B-62
Disc *	Bronze	B-62
Disc Nut	Brass	Commercial
Disc Insert **	PTFE	Commercial

* Brass ASTM B-16 Sizes 1/4" to 1" incl.

** Fig. 578TD and Fig.1825TD

SPECIFICATIONS

- MSS SP-80
- ASME B16.18

FEATURES

- Renewable Discs
- Integral Seats
- 5° Angle Seat for quick response to low pressure differential
- Valves can be used in horizontal or vertical position; however, when installed in vertical line, flow must be upward with pressure under the disc

DIMENSIONS (Inches)

Size	1/4	3/8	1/2	3/4	1	1 1/4	1 1/2	2	2 1/2	3
A(Fig.578)	1 7/8	2 1/4	2 3/4	2 7/8	3 1/4	3 3/4	4 1/4	5 1/4	6 1/4	7 1/4
A1(Fig.1825)-	-	-	3 1/8	4	4 3/8	4 7/8	5 1/8	6 1/8	7 1/4	8 3/8
B	-	-	13/16	1	1 1/16	1 1/8	1 3/16	1 3/8	1 5/8	1 7/8
C*	-	-	.629	.879	1.130	1.380	1.630	2.130	2.633	3.133
G	1 3/16	1 5/16	1 7/16	1 11/16	2 1/16	2 1/2	2 13/16	3 5/16	3 15/16	3 15/16

*Tolerance per ASME B16.18

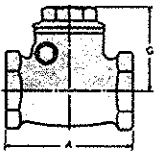

Fig. 578

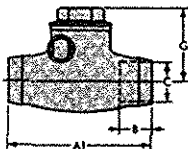

Fig. 1825

WEIGHTS (Pounds)

Fig.578	0.4	0.5	0.7	1.0	1.6	2.3	3.0	6.0	9.0	13.0
Fig.1825	-	-	1.0	1.5	1.5	2.1	3.1	5.0	8.6	13.6

BRONZE "Y" SWING CHECK VALVES

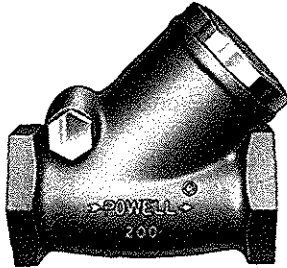

Fig. 560
Class 200
Sizes 1/4" through 3"
Fig. 560TD
Soft Seat (1)
Sizes 1/4" through 3"

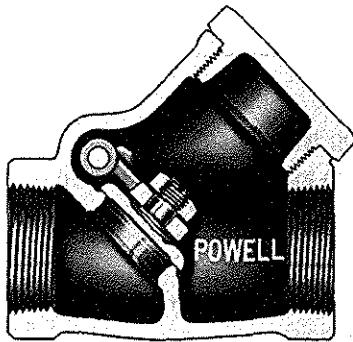

Fig. 563
Class 300
Sizes 1/4" through 3"

(1) Recommended Maximum Temperature
for PTFE Seat is 450°F

CLASS 200 and 300 SCREWED-IN CAP THREADED ENDS

PRESSURE/TEMPERATURE RATINGS

Class 200 Fig. 560

200 psi Steam at 550°F
400 psi Non-Shock Cold Water, Oil or Gas

Class 300 Fig. 563

300 psi Steam at 550°F
600 psi Non-Shock Cold Water, Oil or Gas

MATERIALS

DESCRIPTION	MATERIAL	ASTM Spec.
Side Plug	Brass	B-16
Cap *	Bronze	B-61
Body	Bronze	B-61
Carrier Pin	Brass	B-16
Carrier **	Bronze	B-62
Disc ***	Bronze	B-61
Disc Nut	Brass	Commercial
Disc Insert ****	PTFE	Commercial

- * Brass ASTM B-16 Sizes 1/4" to 3/4" incl.
- ** Brass ASTM B-124 Alloy C37700 Sizes 1/4" to 1" incl.
- *** Silicon Bronze B-371 C69400 Sizes 1/4" to 1" incl.
- **** Fig. 560TD

SPECIFICATIONS

- MSS SP-80

FEATURES

- Renewable Disc is held by a locknut
- Integral Seats
- By unscrewing the side plug and removing the cap and carrier pin, the carrier and disc assembly can be easily removed
- Valves can be used in horizontal or vertical position; however, when installed in vertical line, flow must be upward with pressure under the disc

DIMENSIONS (Inches) Fig. 560

Size	1/4	3/8	1/2	3/4	1	1 1/4	1 1/2	2	2 1/2	3
A	2 1/4	2 3/8	2 3/4	3 1/8	3 5/8	4 3/8	5	6 1/8	7 1/4	8 1/2
G	1 3/8	1 3/8	1 11/16	2	2 3/8	3	3 1/2	4 1/4	5 1/16	5 7/8

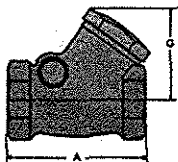

Fig. 560
Fig. 563

DIMENSIONS (Inches) Fig. 563

Size	1/4	3/8	1/2	3/4	1	1 1/4	1 1/2	2	2 1/2	3
A	2 3/8	2 1/2	2 7/8	3 1/4	3 3/4	4 1/2	5 1/8	6 3/8	7 1/2	8 3/4
G	1 1/2	1 1/2	1 13/16	2 1/8	2 1/2	3 1/8	3 9/16	4 3/8	5 3/16	6

WEIGHTS (Pounds)

Fig. 560	0.6	0.6	0.8	1.3	2	3.4	4.8	8	13.7	20.3
Fig. 563	0.7	0.7	1	1.6	2.3	4.1	5.9	10.3	17	25.3

**BRONZE LIFT
CHECK VALVES**
"MODEL STAR"

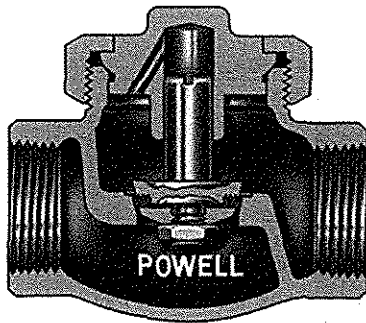

Fig. 116TD (1)
Soft Seat
Class 200 Threaded
Sizes, 1/4" through 2"

**CLASS 200
UNION CAP
THREADED ENDS**

PRESSURE/TEMPERATURE RATINGS
200 psi Steam at 550°F
400 psi Non-Shock Cold Water, Oil or Gas

MATERIALS

DESCRIPTION	MATERIAL	ASTM Spec.
Disc Guide 1/4" - 1 1/4"	Silicon Bronze	B-371 C69400
1 1/2" - 2"	Bronze	B-61
Ring Nut	Bronze	B-61
Disc Holder	Silicon Bronze	B-371 C69400
Body	Bronze	B-61
Disc Insert	PTFE	Commercial
Disc Plate	Silicon Bronze	B-371 C69400
Disc Nut	Brass	Commercial

FEATURES

- Renewable Plug type Discs
- Spindle Guide on top of the disc is guided by a collar which is held in position by the union cap. Guide collar is self centering by a bevel joint in the neck end of the body.
- Integral Seats have an opening equal to the nominal pipe size of the valve
- Valves should be installed with pressure under the disc

(1) Recommended Maximum temperature for PTFE Seat is 450°F

DIMENSIONS (Inches)

Size	1/4	3/8	1/2	3/4	1	1 1/4	1 1/2	2
A	2 1/8	2 1/4	2 1/2	3	3 9/16	4 1/8	4 5/8	5 3/4
G	1 13/32	1 13/32	1 1/2	1 13/16	2 1/16	2 3/8	2 27/32	3 23/32

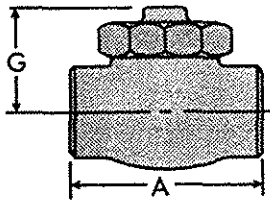

WEIGHTS (Pounds)

Fig.116TD	0.6	0.6	0.9	1.6	2.4	3.8	4.4	9.7
-----------	-----	-----	-----	-----	-----	-----	-----	-----

IRON CLIP GATE VALVES

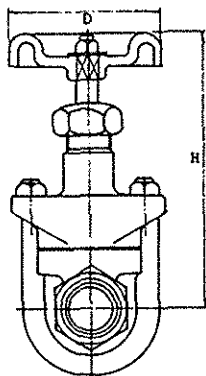

Fig. 3460
Bronze Trimmed

Fig. 3462
All Iron,
Threaded
Sizes, 1/4"
Through 4"

DIMENSIONS

Size	FACE TO FACE	H	D	WT Lbs
1/4"-1/2"	2.09	5	2 1/8	1.5
3/4"	2.36	6.22	2 7/16	2
1"	2.59	7.5	2 61/64	3
1 1/4"	2.88	9	2 61/64	5
1 1/2"	3.14	9.14	3 3/4	6.5
2"	3.70	11.58	3 5/32	10
2 1/2"	4.17	12.88	4 49/64	16
3"	4.56	14.77	6	24
4"	5.67	19.3	9	48

End Threaded to ASME B1.20.1

CLASS 150 INSIDE SCREW RISING STEM THREADED ENDS

PRESSURE/TEMPERATURE RATINGS

1/4" to 2" 150 psi Steam
225 psi Non-Shock Cold Water, Oil or Gas

2 1/2" to 4" 120 psi Steam
175 psi Non-Shock Cold Water, Oil or Gas

MATERIALS

DESCRIPTION	MATERIAL	ASTM Spec.
Body	1/4" to 1" Ductile Iron	A536
	1 1/4"-4" Cast Iron	A126-B
Bonnet	1/4" to 1/2" Ductile Iron	A536
	3/4" - 4" Cast Iron	A126-B
Disc	1/4" to 1" Ductile Iron	A536
	1 1/4" - 4" Cast Iron	A126-B
Stem	Stainless Steel	Type 410
Packing	Graphite Non-Asbestos	

IRON BODY BRONZE TRIMMED GATE VALVES

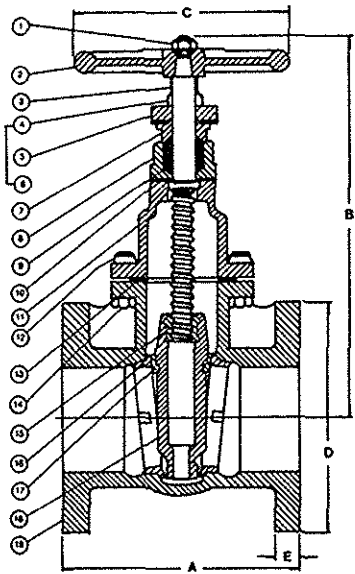

Fig. 1787
Flanged, Bronze Trimmed - Sizes, 2" - 24"

CLASS 125 INSIDE SCREW NON-RISING STEM BOLTED FLANGED BONNET FLANGED ENDS

PRESSURE/TEMPERATURE RATINGS

2" to 12"	125 psi Steam at 450°F
	200 psi Non-Shock Cold Water, Oil or Gas
14" to 24"	100 psi Steam at 350°F
	150 psi Non-Shock Cold Water, Oil or Gas

MATERIALS

DESCRIPTION	MATERIAL	ASTM Spec.
1 Handwheel Nut	Steel	A-307
2 Handwheel	Cast Iron	A-126-B
3 Stem	Brass	B-16
4 Packing Gland Nut	Steel	A-307
5 Packing Gland Follower	Ductile Iron	A-536
6 Packing Gland Stud	Steel	A-307
7 Packing Gland	Cast Bronze	B-62
8 Stuffing Box	Cast Iron	A-126-B
9 Packing	Non-Asbestos Braided Fiber	
10 Stuffing Box Gasket	Non-Asbestos	
11 Bonnet	Cast Iron	A-126-B
12 Bonnet Bolt	Steel	A-307
13 Bonnet Gasket	Non-Asbestos	
14 Bonnet Bolt Nut	Steel	A-307
15 Disc Nut	Cast Bronze	B-62
16 Body Seat Ring	Cast Bronze	B-62
17 Disc Seat Ring	Cast Bronze	B-62
18 Disc	Cast Iron	A-126-B
19 Body	Cast Iron	A-126-B

FEATURES

- Solid Wedges
- Renewable Seat Rings in Bronze Trimmed valves
- Body has five Tapping Bosses

SPECIFICATIONS

- Conforms to MSS SP-70 Type 1

DIMENSIONS (Inches)

Size	2	2 1/2	3	4	5	6	8	10	12	14	16	18	20	24
A	7	7 1/2	8	9	10	10 1/2	11 1/2	13	14	15	16	17	18	20
B	12 15/16	13 1/4	15	17 3/4	20 3/16	23 1/8	27 3/4	32 15/16	37 3/8	41 3/8	46 7/8	49 7/8	54 3/8	64 1/4
C	7	7	8	10	12	12	14	16	18	20	22	24	24	30
D	6	7	7 1/2	9	10	11	13 1/2	16	19	21	23 1/2	25	27 1/2	32
E	5/8	11/16	3/4	15/16	15/16	1	1 1/8	1 3/16	1 1/4	1 3/8	1 7/16	1 9/16	1 11/16	1 7/8

WEIGHTS (Pounds)

Fig. 1787

33	44	55	95	132	172	271	381	578	600	1165	1462	1801	2600
----	----	----	----	-----	-----	-----	-----	-----	-----	------	------	------	------

IRON BODY BRONZE TRIMMED and ALL IRON GATE VALVES

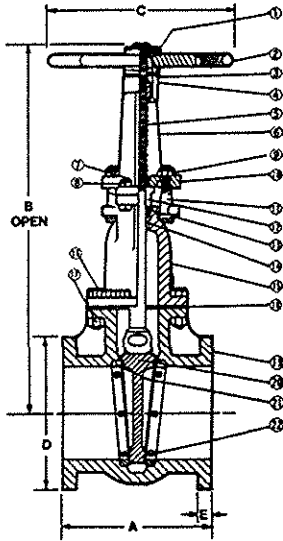

Fig. 1793
Flanged, Bronze Trimmed
Fig. 1816 Flanged, All Iron
Sizes, 2"-36"

FEATURES

- Solid Wedges
- Renewable Seat Rings in Bronze Trimmed valves. Integral seats in All Iron Valves
- Body has five Tapping Bosses

CLASS 125 OUTSIDE SCREW RISING STEM BOLTED FLANGED YOKE-BONNET FLANGED ENDS

PRESSURE/TEMPERATURE RATINGS

2" to 12"	125 psi Steam at 450°F
	200 psi Non-Shock Cold Water, Oil or Gas
14" to 24"	100 psi Steam at 350°F
	150 psi Non-Shock Cold Water, Oil or Gas
30" & 36"	150 psi Non-Shock Cold Water, Oil or Gas

MATERIALS

	DESCRIPTION	MATERIAL	ASTM Spec.
1	Handwheel Nut	Ductile Iron Cast Iron	A-536
2	Handwheel	Cast Iron	A-126-B
3	Yoke Bushing Nut	Cast Iron	A-126-B
4	Yoke Busing	Cast Bronze	B-62
5	Stem	Brass	B-16
6	Yoke	Cast Iron	A-126-B
7	Yoke Bolt	Steel	A-307-B
8	Yoke Bolt Nut	Steel	A-307-B
9	Packing Gland Nut	Steel	A-307-B
10	Packing Gland Flange	Ductile iron	A-536
11	Packing Gland Stud	Steel	A-307-B
12	Packing Gland	Cast Bronze	B-62
13	Packing	Non-Asbestos Braided Fiber	
14	Backseat Bushing	Cast Bronze	B-62
15	Bonnet	Cast Iron	A-126-B
16	Bonnet Bolt	Steel	A-307-B
17	Bonnet Bolt Nut	Steel	A-307-B
18	Bonnet Gasket	Non-Asbestos	
19	Body	Cast Iron	A-126-B
20	Disc	Cast Iron	A-126-B
21	Body Seat Ring	Cast Bronze	B-62
22	Disc Seat Ring	Cast Bronze	B-62

SPECIFICATIONS

- Conforms to MSS SP-70 Type 1

DIMENSIONS (Inches)

Size	2	2 1/2	3	4	5	6	8	10	12	14	16	18	20	24	30	36
A	7	7 1/2	8	9	10	10 1/2	11 1/2	13	14	15	16	17	18	20	24	28
B	14 23/32	16 21/32	18 55/64	23 7/16	27 23/32	32 1/4	39 29/64	48 5/32	56 1/16	62 7/16	71 1/16	79	87 1/8	100 1/16	135	160
C	7	7	8	10	12	12	14	16	18	20	22	24	24	30	36	46
D	6	7	7 1/2	9	10	11	13 1/2	16	19	21	23 1/2	25	27 1/2	32	38 3/4	46
E	5/8	11/16	3/4	15/16	15/16	1	1 1/8	1 3/16	1 1/4	1 3/8	1 7/16	1 9/16	1 11/16	1 7/8	2 1/8	2 3/8

WEIGHTS (Pounds)

Fig. 1793	36	48	62	108	145	186	294	460	618	880	1166	1467	1824	2618	4800	8700
Fig. 1816	36	48	60	103	143	186	298	441	628	880	1166	1467	1824	2618	4800	8700

IRON BODY BRONZE TRIMMED GATE VALVES

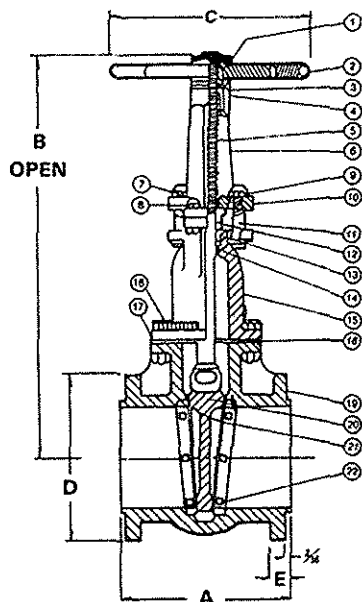

Fig. 1797
Flanged, Bronze Trimmed
Sizes, 2"-12"

FEATURES

- Solid Wedges
- Renewable Seat Rings in Bronze Trimmed valves
- Body has five Tapping Bosses

CLASS 250 OUTSIDE SCREW RISING STEM BOLTED FLANGED YOKE-BONNET FLANGED ENDS

PRESSURE/TEMPERATURE RATINGS

2" to 12" 250 psi Steam at 450°F
500 psi Non-Shock Cold Water, Oil or Gas

MATERIALS

DESCRIPTION	MATERIAL	ASTM Spec.
1 Handwheel Nut	Ductile Iron	A-536
2 Handwheel	Cast Iron	A-126-B
3 Yoke Bushing Nut	Cast Iron	A-126-B
4 Yoke Busing	Cast Bronze	B-62
5 Stem	Brass	B-16
6 Yoke	Cast Iron	A-126-B
7 Yoke Bolt	Steel	A-307
8 Yoke Bolt Nut	Steel	A-307
9 Packing Gland Nut	Steel	A-307
10 Packing Gland Flange	Ductile Iron	A-536
11 Packing Gland Stud	Steel	A-307
12 Packing Gland	Cast Bronze	B-62
13 Packing	Non-Asbestos Braided Fiber	
14 Backseat Bushing	Cast Bronze	B-62
15 Bonnet	Cast Iron	A-126-B
16 Bonnet Bolt	Steel	A-307
17 Bonnet Bolt Nut	Steel	A-307
18 Bonnet Gasket	Non-Asbestos	
19 Body	Cast Iron	A-126-B
20 Disc	Cast Iron	A-126-B
21 Body Seat Ring	Cast Bronze	B-62
22 Disc Seat Ring	Cast Bronze	B-62

SPECIFICATIONS

- WW-V-58 Class 2, Type 1 & MSS SP-70

DIMENSIONS (Inches)

Size	2	2 1/2	3	4	5	6	8	10	12
A	8 1/2	9 1/2	11 1/8	12	15	15 7/8	16 1/2	18	19 3/4
B	15 1/2	17 1/16	19 3/8	23 5/8	27 5/8	32 3/16	40 9/16	49 3/64	56 25/32
C	7	8	10	12	12	14	16	18	20
D	6 1/2	7 1/2	8 1/4	10	11	12 1/2	15	17 1/2	20 1/2
E	7/8	1	1 1/8	1 1/4	1 3/8	1 7/16	1 5/8	1 7/8	2

WEIGHTS (Pounds)

Fig. 1797	53	70	102	157	198	259	451	649	913
-----------	----	----	-----	-----	-----	-----	-----	-----	-----

3% NICKEL CAST IRON GATE VALVE

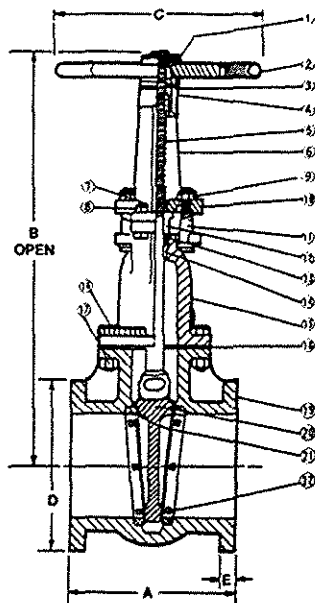

**Fig. 1893 - Flanged
Separable Yokearms
Sizes, 2" through 24"**

FEATURES

- These valves are recommended for causticizing, lime recovery, sulphate pulp preparation, paper mill recovery and general process applications
- Solid Wedges

CLASS 125 OUTSIDE SCREW RISING STEM BOLTED FLANGED YOKE-BONNET FLANGED ENDS

PRESSURE/TEMPERATURE RATINGS

2" to 12"	125 psi Steam at 450°F
	200 psi Non-Shock Cold Water, Oil or Gas
14" to 24"	100 psi Steam at 350°F
	150 psi Non-Shock Cold Water, Oil or Gas

MATERIALS

DESCRIPTION	MATERIAL	ASTM Spec.
1 Handwheel Nut	Ductile Iron Cast Iron	A-536
2 Handwheel	Cast Iron	A-126-B
3 Yoke Bushing Nut	Cast Iron	A-126-B
4 Yoke Busing	Cast Bronze	B-62
5 Stem	Stainless Steel	A-182 Gr. F-316
6 Yoke	Cast Iron	A-126-B
7 Yoke Bolt	Steel	A-307-B
8 Yoke Bolt Nut	Steel	A-307-B
9 Packing Gland Nut	Steel	A-307-B
10 Packing Gland Flange	Ductile iron	A-536
11 Packing Gland Stud	Steel	A-307-B
12 Packing Gland	Cast Bronze	B-62
13 Packing	Non-Asbestos	
14 Backseat Bushing	Stainless Steel	A-182 Gr. F-316
15 Bonnet	Cast Iron Ni	3% Nickel
16 Bonnet Bolt	Steel	A-307-B
17 Bonnet Bolt Nut	Steel	A-307-B
18 Bonnet Gasket	Non-Asbestos	
19 Body	Cast Iron Ni	3% Nickel
20 Disc 2"-3"	Stainless Steel	A-182 Gr F-316
*4" and Larger	Cast Iron Ni	3% Nickel
21 Body Seat Ring	Stainless Steel	A-182 Gr. F-316
22 Disc Seat Ring	Stainless Steel	A-182 Gr. F-316

*Nickel Iron Disc with Stainless Steel Facing

SPECIFICATIONS

- WW-V-58 Class 2, Type 1 & MSS SP-70

DIMENSIONS (Inches)

Size	2	2 1/2	3	4	5	6	8	10	12	14	16	18	20	24
A	7	7 1/2	8	9	10	10 1/2	11 1/2	13	14	15	16	17	18	20
B	14 23/32	16 21/32	18 55/64	23 7/16	27 23/32	32 1/4	39 29/64	48 5/32	56 1/16	62 7/16	71 1/16	79	87 1/8	100 1/16
C	7	7	8	10	12	12	14	16	18	20	22	24	24	30
D	6	7	7 1/2	9	10	11	13 1/2	16	19	21	23 1/2	25	27 1/2	32
E	5/8	11/16	3/4	15/16	15/16	1	1 1/8	1 3/16	1 1/4	1 3/8	1 7/16	1 9/16	1 11/16	1 7/8

WEIGHTS (Pounds)

Fig. 1893

36	48	60	103	143	186	298	441	628	880	1166	1467	1824	2618
----	----	----	-----	-----	-----	-----	-----	-----	-----	------	------	------	------

IRON BODY BRONZE TRIMMED GLOBE VALVES

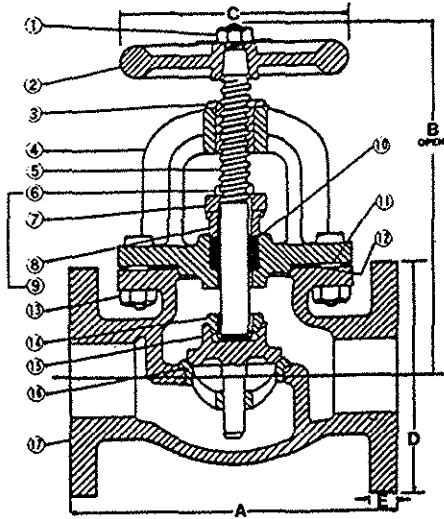

Fig. 241
Globe, Flanged
Bronze Trimmed
Sizes, 2" through 12"

CLASS 125 OUTSIDE SCREW STEM BOLTED FLANGED YOKE-BONNET FLANGED ENDS

PRESSURE/TEMPERATURE RATINGS

2" to 12" 125 psi Steam at 450°F
200 psi Non-Shock Cold Water, Oil or Gas

MATERIALS

DESCRIPTION	MATERIAL	ASTM Spec.
1 Handwheel Nut	Steel	A-307
2 Handwheel	Cast Iron	A-126-B
3 Yoke Bushing	Cast Bronze	B-62
4 Bonnet	Cast Iron	A-126-B
5 Stem	Brass	B-16
6 Packing Gland Nut	Steel	A-307
7 Packing Gland Follower	Ductile Iron	A-536
8 Packing Gland	Cast Bronze	B-62
9 Packing Gland Stud	Steel	A-307
10 Packing	Non-Asbestos Braided Fiber	
11 Bonnet Bolt	Steel	A-307
12 Body Gasket	Non-Asbestos	
13 Bonnet Bolt Nut	Steel	A-307
14 Swivel Nut	Cast Bronze	B-62
15 Disc *	Cast Bronze	B-62
16 Body Seat Ring	Cast Bronze	B-62
17 Body	Cast Iron	A-126-B

*5"-12" Iron Disc with Bronze Disc Facing

FEATURES

- Renewable Seat and Disc

SPECIFICATIONS

- Conforms to MSS SP-85 Type 1
- Body has five tapping Bosses

DIMENSIONS (Inches)

Size	2	2 1/2	3	4	5	6	8	10	12
A	8	8 1/2	9 1/2	11 1/2	13	14	19 1/2	24 1/2	27 1/2
B	11 15/16	12 13/16	13 5/8	14 9/16	17 3/4	19 11/16	22 11/16	27	29 13/16
C	7	7	8	10	12	12	14	16	18
D	6	7	7 1/2	9	10	11	13 1/2	16	19
E	5/8	11/16	3/4	15/16	15/16	1	1 1/8	1 3/16	1 1/4

WEIGHTS (Pounds)

Fig. 241	36	49	57	95	139	183	378	523	700
----------	----	----	----	----	-----	-----	-----	-----	-----

IRON BODY BRONZE TRIMMED and ALL IRON SWING CHECK VALVES

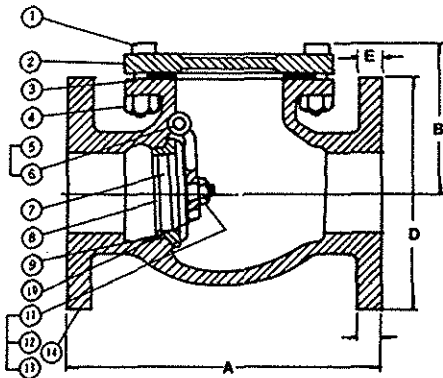

Fig. 559
Bronze Trimmed, Flanged
Fig. 1259-All Iron, Flanged
Sizes, 2" through 18"

SPECIFICATIONS

•Conforms to MSS SP-71 Type 1

DIMENSIONS (Inches)

Size	2	2 1/2	3	4	5	6	8	10	12	14	16	18
A	8	8 1/2	9 1/2	11 1/2	13	14	19 1/2	24 1/2	27 1/2	31	36	36
B	4 11/16	5 3/8	5 3/4	6 11/16	7 3/4	8 1/2	10 3/8	11 15/16	13 1/2	15 1/2	16 5/8	19 5/16
D	6	7	7 1/2	9	10	11	13 1/2	16	19	21	23 1/2	25
E	5/8	11/16	3/4	15/16	15/16	1	1 1/8	1 3/16	1 1/4	1 3/8	1 7/16	1 9/16
Wt.	25	36	48	80	113	152	252	416	606	794	1020	1304

CLASS 125

BOLTED FLANGED CAP • FLANGED ENDS

PRESSURE/TEMPERATURE RATINGS

2" to 12"	125 psi Steam at 450°F
	200 psi Non-Shock Cold Water, Oil or Gas
14" to 18"	100 psi Steam at 350°F
	150 psi Non-Shock Cold Water, Oil or Gas

MATERIALS

DESCRIPTION	MATERIAL	ASTM Spec
1 Cover Bolt	Steel	A-307-B
2 Cover	Cast Iron	A-126-B
3 Cover Gasket	Non-Asbestos	
4 Cover Bolt Nut	Steel	A-307
5 Hanger Pin	Brass	B-16
6 Side Plug	Brass	B-16
7 Disc	Cast Iron	A-126-B
8 Disc Seat Ring	Cast Bronze	B-62
9 Body Seat Ring	Cast Bronze	B-62
10 Hanger	Ductile Iron	A-536
11 Disc Nut	Steel	A-307
12 Washer	Steel	A-307
13 Split Pin	Stainless Steel	SUS 410
14 Body	Cast Iron	A-126-B

3% NICKEL CAST IRON SWING CHECK VALVE

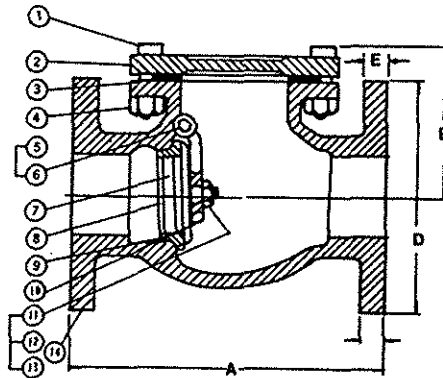

Fig. 559P
Swing Check Valve
Sizes, 2" through 18"

CLASS 125 BOLTED CAP • FLANGED ENDS

PRESSURE/TEMPERATURE RATINGS

2" to 12"	125 psi Steam at 450°F
	200 psi Non-Shock Cold Water, Oil or Gas
14" to 18"	100 psi Steam at 350°F
	150 psi Non-Shock Cold Water, Oil or Gas

MATERIALS

DESCRIPTION	MATERIAL	ASTM Spec
1 Cover Bolt	Stainless Steel	A-276 Type 304
2 Cover	Cast Iron Ni	3% Nickel
3 Cover Gasket	Non-Asbestos	
4 Cover Bolt Nut	Stainless Steel	A-582 Type 303
5 Hanger Pin	Stainless Steel	A-276 Type 304
6 Side Plug	Stainless Steel	A-276 Type 304
7 Disc*	2"-3" Stainless Steel	A-182 Gr. F316
8 Disc Seat Ring	Stainless Steel	A-182 Gr. 316
9 Body Seat Ring	Stainless Steel	A-182 Gr. 316
10 Hanger	Stainless Steel	A-351 Gr. CF8M
11 Disc Nut	Stainless Steel	A-582 Type 303
12 Washer	Stainless Steel	A-276 Type 304
13 Split Pin	Stainless Steel	A-276 Type 304
14 Body	Cast Iron Ni	3% Nickel

*4" through 18" 3% Ni Iron Disc with Stainless Facing

Dimensions and Weights Fig. 559P Same As Fig. 559

CAST STEEL VALVES GENERAL INDEX

CAST STEEL BOLTED BONNET

	PAGE
CAST STEEL MATERIALS	29
MATERIALS, STANDARDS and SPECIFICATIONS	29
TRIM MATERIALS and RECOMMENDATIONS	30,31
SEAT RINGS, WEDGES and HAMMERBLOW HANDWHEELS	32
STANDARD PACKING ARRANGEMENT, FUGITIVE EMISSIONS OPTIONS and LANTERN RINGS	33

GATE VALVES

Class 150 Size 1" through 60"	34-36
Class 300 Size 1" through 42"	37-39
Class 600 through 2500	40-43

GLOBE and ANGLE VALVES

Class 150 through 1500	44-48
----------------------------------	-------

NON-RETURN VALVES

Class 300 and 600	49, 50
-----------------------------	--------

SWING CHECK VALVES

Class 150 through 1500	51-55
----------------------------------	-------

TILTING DISC CHECK VALVES

Class 150 through 1500	56
----------------------------------	----

CAST STEEL PRESSURE SEAL

PRESSURE SEAL DESIGN and CONSTRUCTION	57-59
---	-------

GATE VALVES

Class 600 - 2500	60-62
Class 600 Venturi Design	63

GLOBE and ANGLE VALVES

Class 600 - 2500	64-67
Class 600 - 2500 Non-Return	68-71

CHECK VALVES

Class 600 - 2500 Horizontal, Angle, Y Lift and Swing Check	72-75
TILTING DISC CHECK VALVES	76
VALVES with BY-PASS	77,78
MOTOR OPERATED VALVES	79
ADAPTO GEAR ACTUATORS	134

Powell Cast Steel Valves are available in standard to highly specialized designs for Nuclear Service, HF Service and NACE requirements (National Association of Corrosion Engineers).

CAST STEEL MATERIALS

Cast Carbon Steel	ASTM A216, Grade WCB
Cast Chromium-Molybdenum Alloy Steel	ASTM A217, Grade WC6
Cast Chromium-Molybdenum Alloy Steel	ASTM A217, Grade WC9
Cast 4-6% Chromium-Molybdenum Alloy Steel	ASTM A217, Grade C5
Cast 8-10% Chromium-Molybdenum Alloy Steel	ASTM A217, Grade C12
Cast 8-10% Chromium-Molybdenum Vanadium Alloy Steel	ASTM A217, Grade C12A
Cast Carbon Steel	ASTM A352, Grade LCB
Cast 3 1/2% Nickel Steel	ASTM A352, Grade LC3

STANDARD and SPECIFICATIONS

In the interest of uniformity and safety for the consumer, a number of national organizations have developed and published Standards and Specifications. These standards and specifications prescribe the rules and regulations for the construction of boilers and pressure vessels, including valves and safety appliances, specifications for materials, dimensional standards and requirements for piping system. Powell Valves and Engineering Specialties, wherever applicable, conform to the requirements set forth in the publications (latest editions) of these associations.

API-	American Petroleum Institute - Specifications	ASTM-	American Society for Testing Materials - Material Specifications
ANSI-	American National Standards Institute - Codes and Standards	MSS-	Manufacturers' Standardization Society of the Valve and Fittings Industry - Standard Practices
ASME-	American Society of Mechanical Engineers - Boiler and Pressure Vessel Code	NACE-	National Association of Corrosion Engineers

CAST STEEL VALVE TEST STANDARDS

Shell and Seat Test Pressures and Test Procedures are as outlined in the following standards

BOLTED BONNET VALVES
ASME B16.34
MSS SP-61
API 598

PRESSURE SEAL VALVES
ASME B16.34
MSS SP-61

POWELL TRIM MATERIALS

HF - NON-FERROUS HARD FACING ALLOY-STELLITE

Because of its hardness and ability to maintain toughness at elevated temperatures, Stellite Hard Facing Alloy is ideal and especially recommended for facing valve seats, wedges and discs used in services where high temperatures and erosion are encountered.

Powell engineers pioneered the hard facing of valve seats, wedges and discs. Careful study, scientific research and development made it possible to apply this material commercially. It is fused on and inseparably bonded to base materials.

Powell valve seats, wedges and discs hard faced give long, satisfactory service and do not require frequent or continuous lapping or refacing - advantages proved by successful Powell Valve installations everywhere.

CR-13 - STAINLESS STEEL (13% Chrome)

Powell Stainless Steel, used for valve trim, is a high chromium alloy material produced for valve seating faces and stems or spindles. This Stainless Steel is carefully heat treated for maximum wear requirements. By altering the heat treatment a variation in the hardness of Stainless Steel seat and disc faces is obtained. This greatly minimizes the seizing and galling action between the seats and discs.

NI-CU - NICKEL COPPER ALLOY-MONEL

316 SS - HIGH CHROMIUM-NICKEL-MOLYBDENUM STEEL

NACE - HYDROGEN SULFIDE SERVICE

Special trims are available for resistance to sulfide stress cracking in valves subjected to hydrogen sulfide per NACE MR0175 standards.

OTHER TRIMS

Other trim combinations are available for specific applications.

VALVE TRIM RECOMMENDATIONS

SERVICE - STEAM AND WATER UP TO 850°F.

Gate, Globe, Angle and Check Valves – Wedge or Disc Facing: 13% Chrome Stainless Steel
Seat Ring Facing: Stellite
API Trim 8

SERVICE - STEAM AND WATER UP TO 1200°F

Gate, Globe, Angle and Check Valves – Wedge or Disc Facing: Stellite
Seat Ring Facing: Stellite
API Trim 5

SERVICE - OIL OR OIL VAPOR UP TO 1100°F.

Gate, Globe, Angle and Check Valves – Wedge or Disc Facing: 13% Chrome Stainless Steel
Seat Ring Facing: Stellite
API Trim 8

SERVICE - OIL OR OIL VAPOR OR GAS UP TO 1200°F.

Gate, Globe, Angle and Check Valves – Wedge or Disc Facing: Stellite
Seat Ring Facing: Stellite
API Trim 5

Stems in valves for above services are made of 13% Chrome Stainless Steel.

See page 153 For More Trim Information.

BOLTING MATERIALS

For normal services, studs (threaded full length) conforming to A. S. T. M. Specification A 193 Grade B-7 are furnished, with nuts conforming to A. S. T. M. Specification A 194 Class 2H.

Threads are in accordance with the American Standard for Screw Threads. ASME B1.1 Coarse Thread Series, sizes 1 inch in diameter and smaller; and 8-Pitch Thread Series, 1 1/8 inch in diameter and larger.

**POWELL ALLOY STEEL STUDS
(A. S. T. M. Spec. A193, Grade B-7)**

**POWELL STEEL NUTS
(A. S. T. M. Spec. A194, Class 2H)**

CAST STEEL VALVES

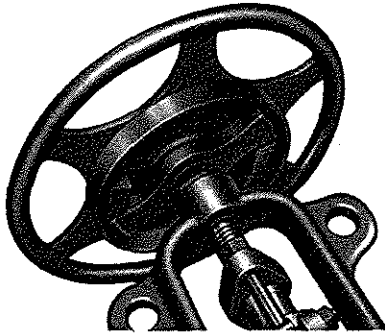

HAMMERBLOW HANDWHEEL

Powell Steel Globe, Angle and Non-Return Valves can be equipped with Hammerblow handwheel providing additional operating torque to facilitate operation of valves in services where the plain handwheel may be insufficient yet where gearing is not necessary. It is regularly supplied on certain large size globe, angle and non-return valves.

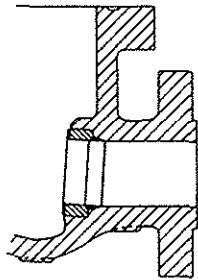

Welded-In Seat Ring
in Gate Valve

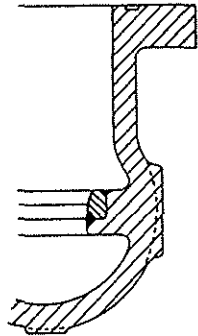

Welded-In Seat Ring
in Globe Valve

SEAT RINGS

Seat rings are of heavy rectangular section, stellite faced (unless otherwise specified) and seat directly against the main wall of the body casting. Gate and Swing Check Valve rings are welded into the valve body. Globe, Angle and Lift Check rings are welded (most pressure seal designs) or threaded (most bolted bonnet designs). When specified, threaded rings can be seal welded. Seat rings with PTFE inserts can be supplied on special order.

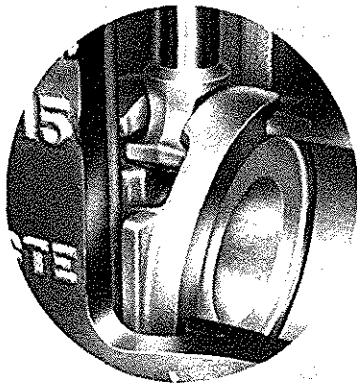

Sectional View illustrating the
guiding of the wedge

WEDGES FOR GATE VALVES

Gate Valve Wedges are one piece solid construction with integral guides to mate with the body guides. The wedges are precision machined and fitted. Most wedges are flexible type with cast or saw cut groove and solid center hub. This design allows minimum operating torque for tight shut off and reduces the negative effects of thermal expansion and contraction.

CAST STEEL VALVES

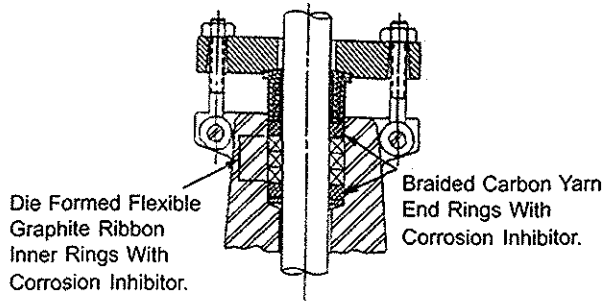

STANDARD PACKING ARRANGEMENT

Powell standard design cast and low alloy steel valves are designed and manufactured to meet Level I-500 ppm maximum fugitive emissions. Level II-100 ppm maximum emissions-is optionally available.

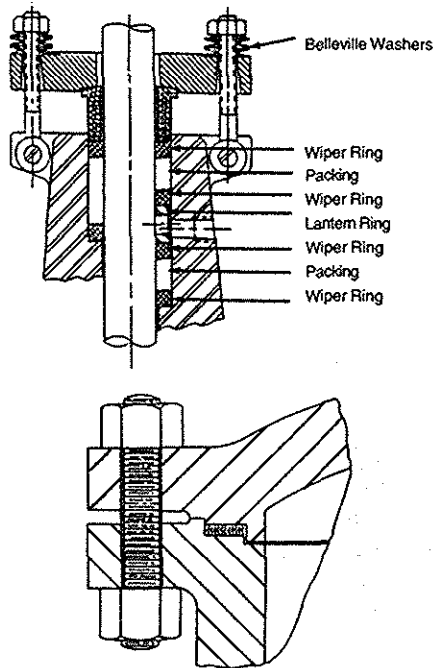

FUGITIVE EMISSIONS OPTIONS

PACKING DESIGN

Illustration Of Optional Live Load Design with standard packing (left side of centerline) and Live Load Design with Lantern Ring Arrangement (right side of centerline)

GASKET DESIGN

Contained Controlled Compression Spiral Wound Gasket

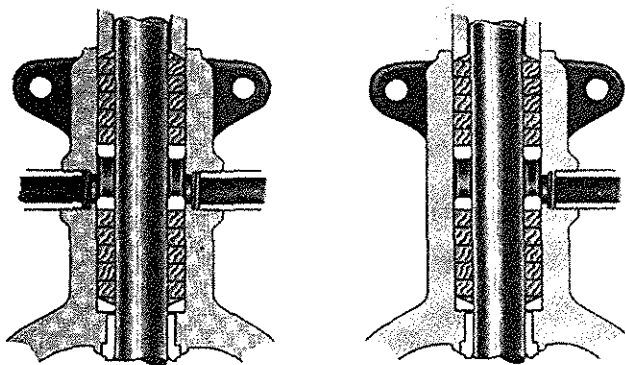

LANTERN RINGS

Lantern Rings, when ordered in cast steel valves, can be substituted for condensing chambers. This permits sufficient packing at the bottom and top of the stuffing box.

Lantern rings are used where hazardous media passes through the valves, or where customer requests a valve for an inert gas or a steam packed valve or a method for providing lubrication at this point. They can be supplied with one bonnet connection for detection or draining or two connections for flushing.

CAST STEEL GATE VALVES

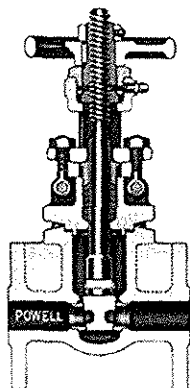
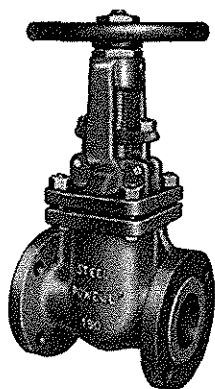

Fig. 1503

Sizes, 1" and 1 1/2"

For Sizes, 2" and Larger see pages 35, 36

FEATURES

- Solid Wedges are accurately guided to the seating surfaces
- Seat Rings are welded in valve body
- Male and female bonnet joint assure alignment and compress the gasket eliminating any possibility of a blow-out

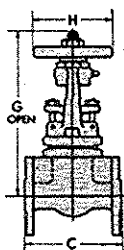

CLASS 150

OUTSIDE SCREW RISING STEM BOLTED FLANGED YOKE-BONNET FLANGED ENDS

PRESSURE/TEMPERATURE RATINGS

In accordance with ASME B16.34

MATERIALS

DESCRIPTION	MATERIAL	ASTM Spec.
Stem Bushing	Aluminum Bronze	B505 Alloy 95400
Stem Bushing Locknut	Stainless Steel	A-582, Type 416
Name Plate	Aluminum	Commercial
Handwheel	Malleable Iron	A-47, Grade 32510
Handwheel Key	Steel	A-108, Grade 1020
Bushing Retainer	Steel	AISI C-12, L-14
Grease Fitting	Steel	Commercial
Yoke	Steel	A-216, Grade WCB
Stem	Stainless Steel	† A-182, Grade F6a
Gland Eyebolt Nut	Stainless Steel	A-194, Grade B8
Gland Eyebolt	Stainless Steel	Commercial
Gland Eyebolt Pin	Steel	Commercial
Gland Flange	Steel	Commercial
Gland Follower	Steel	A-108, Grade 1020
Packing	Grafoil	Commercial
Yoke Bolt	Steel	A-193, Grade B7
Yoke Bolt Nut	Steel	A-194, Grade 2H
Gasket (Corrugated)	Stainless Steel/Graphite Coated	Commercial
Body	Steel	A-216, Grade WCB
Disc	Stainless Steel	A-217, Grade CA15
Seat Ring	Stainless Steel	A-312, Type 316

† Or Equal

GRAFOIL® trademark of Union Carbide Corporation

SPECIFICATIONS

- Flanged End valves have dimensions conforming to ASME B16.5 and B16.10
- Flanged End valves can be furnished with ring joint flanges

ORDERING

- Double Wedges are available on special order and are interchangeable with the Solid Wedge

DIMENSIONS (Inches)

Size	1	1 1/2
C	5	6 1/2
G	10	12 3/4
H	4 1/2	6

WEIGHTS (Pounds)

Fig. 1503	14	25
-----------	----	----

CAST STEEL GATE VALVES

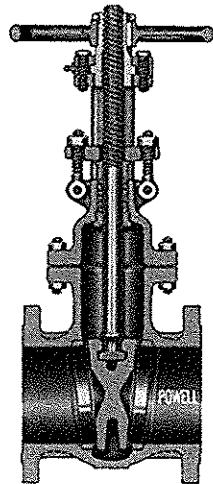

Fig. 1503

Flanged

Fig. 1503WE - Welding
Sizes, 2" through 14"

For Sizes, 16" through 60" see page 36

FEATURES

- Flexible Wedge insures pressure tightness and reduces operating torque needed to open the valve. Solid Wedges are furnished in valves sizes 2" and 2 1/2"
- Stellite faced Seat Rings are welded into the body. This provides a positive no-leak seal of the ring in the valve body and will resist corrosion, erosion and galling
- Bonnet permits easy installation of an actuator, adapto gearing, cylinder or motor
- Valves are furnished with a back seat bushing arrangement in the bonnet
- Valves, sizes 2" and 2 1/2" have square bonnets and nested gasket

CLASS 150

BOLTED FLANGED YOKE-BONNET OUTSIDE SCREW RISING STEM FLANGED and WELDING ENDS

PRESSURE/TEMPERATURE RATINGS

In accordance with ASME B16.34

MATERIALS

DESCRIPTION	MATERIAL	ASTM Spec.
Handwheel Nut	Malleable Iron	A-47, Grade 32510
Handwheel	Malleable Iron	A-47, Grade 32510
Handwheel Key	Steel	A-108, Grade 1015/1025
Stem Bushing Locknut (2"-4")	Malleable Iron	A-47, Grade 32510
Bonnet	Carbon Steel	A-216, Grade WCB
Lubricant Fitting	-	Commercial
Stem Bushing	Ductile Ni-Resist	A-439, Type D2
Stem	Stainless Steel	† A-182, Grade F6a
Eyebolt Nuts	Steel	A-563, Grade A or B
Gland Flange	Steel	AISI 1030
Gland	Steel	A-108, Grade 1015/1025
Groov-Pins	Steel	Commercial
Eyebolts	Steel	A-307, Grade B
Packing	Grafoil	Commercial
Body Nuts	Steel	A-194, Grade 2H
Body Seat Bushing	Stainless Steel	† A-276, Type 410
Body Studs	Steel	A-193, Grade B7
Gasket (Corrugated)	Stainless Steel/Graphite Coated	Commercial
Body	Carbon Steel	A-216, Grade WCB
Seat Rings	Steel/Stellite Facing	A-519, Grade 1015/1025
Wedge	Stainless Steel or Carbon Steel/13% Chrome Facing	A-217, Grade CA15 A-216, Grade WCB
Cap Screws (6"-14")	Steel	A-449
Bearing Cap (6"-14")	Malleable Iron	A-47, Grade 32510

†Or Equal

SPECIFICATIONS

- Flanged and Butt Welding End valves conform to ANSI B16.5, B16.10, B16.25, B16.34 and API 600
- Flanged End valves can be furnished with ring joint flanges

ORDERING

- When ordering Butt Welding End valves, specify schedule of pipe end and give complete data concerning style, figure number and contour of weld end

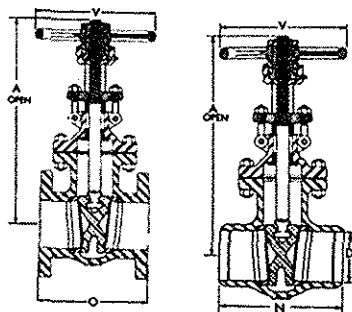

DIMENSIONS (Inches)

Size	2	2 1/2	3	4	6	8	10	12	14
O	7	7 1/2	8	9	10 1/2	11 1/2	13	14	15
N	8 1/2	9 1/2	11 1/8	12	15 7/8	16 1/2	18	19 3/4	22 1/2
A	14 5/8	15 7/8	18 1/8	22 1/8	31	39	47 1/4	55 1/2	65 1/2
V	8	8	9	10	12	14	16	20	22
D	2.067	2.469	3.068	4.026	6.065	7.981	10.02	12.00	13.25

WEIGHTS (Pounds)

Fig.1503	35	50	80	110	190	310	490	700	990
Fig.1503WE	30	40	70	100	180	270	450	640	1015

CAST STEEL GATE VALVES

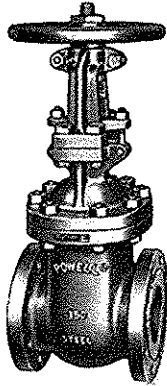

Fig. 1503
Flanged
Fig. 1503WE - Welding
Sizes, 16" through 60"
Above 36" Data on Request

FEATURES

- Solid Wedge is accurately guided to the seating surfaces. Flexible wedge can be furnished when ordered.
- Stellite faced Seat Rings are welded into the body. This provides a positive no-leak seal of the ring in the valve body and will resist corrosion, erosion and galling.
- Lubricant fitting is provided to permit stem bushing lubrication for ease of operation.
- Valves are furnished with a back seat bushing arrangement in the bonnet.

CLASS 150 BOLTED FLANGED YOKE-BONNET OUTSIDE SCREW RISING STEM FLANGED and WELDING ENDS

PRESSURE/TEMPERATURE RATINGS

In accordance with ASME B16.34

MATERIALS

DESCRIPTION	MATERIAL	ASTM Spec.
Handwheel	Malleable Iron	A-47, Grade 32510
Handwheel Key	Steel	A-108, Grade 1015/1025
Handwheel Nut	Malleable Iron	A-47, Grade 32510
Lubricant Fitting	-	Commercial
Stem Bushing	Ductile Ni-Resist	A-439, Type D2
Yokearm Ear Bolts	Steel	A-307, Grade B
Gland	Steel	A-108, Grade 1015/1025
Eyebolt Nuts	Steel	A-563, Grade A or B
Yokearm Ear Nuts	Steel	A-563, Grade A or B
Yokearm	Carbon Steel	A-216, Grade WCB
Eyebolts	Steel	A-307, Grade B
Gland Flange	Carbon Steel	A-216, Grade WCB
Packing	Grafoil	Commercial
Groov-Pins	Steel	Commercial
Packing Washer	Steel	A-108, Grade 1015/1025
Back Seat Bushing	Stainless Steel	† A-276, Type 410
Bonnet	Carbon Steel	A-216, Grade WCB
Gasket (Corrugated)	Stainless Steel/ Graphite Coated	Commercial
Body Nuts	Steel	A-194, Grade 2H
Body Studs	Steel	A-193, Grade B7
Stem	Stainless Steel	† A-182, Grade F6a
Seat Rings	Steel/Stellite Facing	A-519, Grade 1015/1025
Wedge	Carbon Steel/ 13% Chrome Facing	A-216, Grade WCB
Bonnet Studs	Steel	A-193, Grade B7
Bonnet Nuts	Steel	A-194, Grade 2H
Body	Carbon Steel	A-216, Grade WCB

† Or Equal

SPECIFICATIONS

- Flanged End valves have dimensions conforming to ASME B16.5, B16.10, B16.25, B16.34 and API 600
- Flanged End valves can be furnished with ring joint flanges

ORDERING

- When ordering Butt Welding End valves, specify schedule of pipe end and give complete data concerning style, figure number and contour of weld end

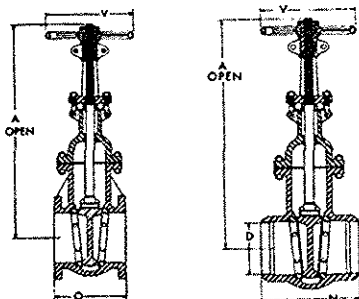

DIMENSIONS (Inches)

Size	16	18	20	24	30	36	40 thru 60
O	16	17	18	20	24	28	
N	24	26	28	32	42	42	Data
V	26	26	26	30	36	36	On
A	75 1/2	83 1/4	92 1/4	108	131 1/2	167 3/4	Request
D	15.25	17.25	19.25	23.25	29.25	35.00	

WEIGHTS (Pounds)

Fig. 1503	1385	1810	2150	3260	5310	
Fig. 1503WE	1500	2060	2360	3480	5480	

CAST STEEL GATE VALVES

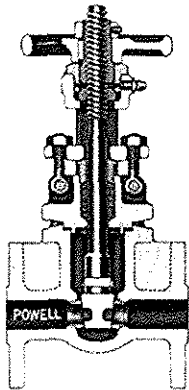
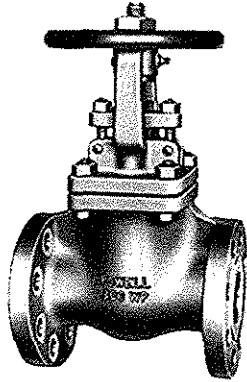

Fig. 3003

Sizes, 1" through 1 1/2"
For Sizes, 2" and Larger see pages 38, 39

FEATURES

- Solid Wedge are accurately guided to the seating surfaces.
- Seat Rings are welded in valve body
- Male and female bonnet joint assure alignment and compresses the gasket eliminating any possibility of a blow-out

CLASS 300 OUTSIDE SCREW RISING STEM BOLTED FLANGED YOKE-BONNET FLANGED ENDS

PRESSURE/TEMPERATURE RATINGS

In accordance with ASME B16.34

MATERIALS

DESCRIPTION	MATERIAL	ASTM Spec.
Yoke Bushing	Aluminum Bronze	B505 Alloy 95400
Yoke Bushing Locknut	Stainless Steel	A-582, Type 416
Name Plate	Aluminum	Commercial
Handwheel	Malleable Iron	A-47, Grade 32510
Handwheel Key	Steel	A-108, Grade 1015/1025
Bushing Retainer	Steel	AISI C-12, L-14
Grease Fitting	Steel	Commercial
Yoke	Steel	A-216, Grade WCB
Stem	Stainless Steel	†A-182, Grade F6a
Gland Eyebolt Nut	Stainless Steel	A-194, Grade B8
Gland Eyebolt	Stainless Steel	Commercial
Gland Eyebolt Pin	Steel	Commercial
Gland Flange	Steel	Commercial
Gland Follower	Steel	A-108, Grade 1020
Packing	Grafoil	Commercial
Yoke Bolt	Steel	A-193, Grade
Yoke Bolt Nut	Steel	A-194, Grade 2H
Gasket (Corrugated)	Stainless Steel/Graphite Coated	Commercial
Body	Steel	A-216, Grade WCB
Disc	Stainless Steel	A-217, Grade CA15
Seat Ring	Stainless Steel	A-312, Type 316
†Or Equal		

SPECIFICATIONS

- Flanged End valves have dimensions conforming to ASME B16.5 and B16.10
- Flanged End valves can be furnished with ring joint flanges

ORDERING

- Double Wedges are available on special order and are interchangeable with the Solid Wedge

DIMENSIONS (Inches)

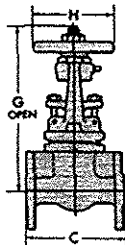

Size	1	1 1/2
C	6 1/2	7 1/2
G	10	12 25/32
H	4 1/2	7

WEIGHTS (Pounds)

Fig. 3003	19	34
-----------	----	----

CAST STEEL GATE VALVES

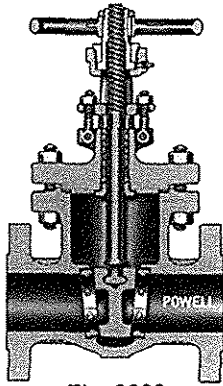

Fig. 3003

Flanged

Fig. 3003WE - Welding
Sizes, 2" through 12"

For Sizes, 14" through 42" see page 39

FEATURES

- Flexible Wedge insures pressure tightness and reduces operating torque needed to open the valve. Solid Wedges are furnished in valves-2" and 2 1/2"
- Stellite faced Seat Rings are welded into the body. This provides a positive no-leak seal of the ring in the valve body and will resist corrosion, erosion and galling
- Bonnet/Yokearm permits easy installation of an actuator, adapto gearing, cylinder or motor
- Valves are furnished with a back seat bushing arrangement in the bonnet
- Valves, sizes 2" and 2 1/2" have square bonnets and nested gasket

ORDERING

- When ordering Butt Welding End valves, specify schedule of pipe end and give complete data concerning style, figure number and contour of weld end

CLASS 300 BOLTED FLANGED YOKE-BONNET OUTSIDE SCREW RISING STEM FLANGED and WELDING ENDS

PRESSURE/TEMPERATURE RATINGS

In accordance with ASME B16.34

MATERIALS

DESCRIPTION	MATERIAL	ASTM Spec.
Handwheel Nut	Malleable Iron	A-47, Grade 32510
Handwheel	Malleable Iron	A-47, Grade 32510
Handwheel Key	Steel	A-108, Grade 1015/1025
Stem Bushing Locknut (2"-4")	Malleable Iron	A-47, Grade 32510
Bonnet	Carbon Steel	A-216, Grade WCB
Lubricant Fitting	-	Commercial
Stem Bushing	Ductile Ni-Resist	A-439, Type D2
Stem	Stainless Steel	† A-182, Grade F6a
Eyebolt Nuts	Steel	A-563, Grade A or B
Gland Flange	Steel	AISI 1030
Gland	Steel	A-108, Gr. 1015/1025
Groov-Pins	Steel	Commercial
Eyebolts	Steel	A-307, Grade B
Packing	Grafoil	Commercial
Body Nuts	Steel	A-194, Grade 2H
Body Seat Bushing	Stainless Steel	† A-276, Type 410
Body Studs	Steel	A-193, Grade B7
Gasket (Double Jacket)	Soft Iron/Steel *	Commercial
Body	Carbon Steel	A-216, Grade WCB
Seat Ring	Steel/Stellite Facing	A-519, Gr. 1015/1025
Wedge	Stainless Steel or Carbon Steel/13% Chrome Facing	A-217, Grade CA15 A-216, Grade WCB
Cap Screws (6"-12")	Steel	A-449
Bearing Cap (6"-12")	Malleable Iron	A-47, Grade 32510
Yokearm (10"-12")	Carbon Steel	A-216, Grade WCB
Yokearm Nuts (10"-12")	Steel	A-194, Grade 2H
Yokearm Studs (10"-12")	Steel	A-193, Grade B7
Packing Washer	Steel	A-108, Gr. 1015/1025
Packing Spacer	Steel	A-108, Gr. 1015/1025

† Or Equal

* Non-Asbestos Insert

SPECIFICATIONS

- Flanged and Butt Welding End valves conform to ASME B16.5 B16.10, B16.25, B16.34 and API 600
- Flanged End valves can be furnished with ring joint flanges

DIMENSIONS (Inches)

Sizes	2	2 1/2	3	4	6	8	10	12
O	8 1/2	9 1/2	11 1/8	12	15 7/8	16 1/2	18	19 3/4
N	8 1/2	9 1/2	11 1/8	12	15 7/8	16 1/2	18	19 3/4
A	15 1/2	16 3/4	19 1/4	23 7/8	33 1/8	41 1/4	50 1/4	57 5/8
V	8	8	9	10	14	16	20	20
D	2.067	2.469	3.068	4.026	6.065	7.981	10.02	12.00

WEIGHTS (Pounds)

Fig. 3003	57	85	110	165	320	500	800	1230
Fig. 3003WE	45	60	80	120	250	410	690	940

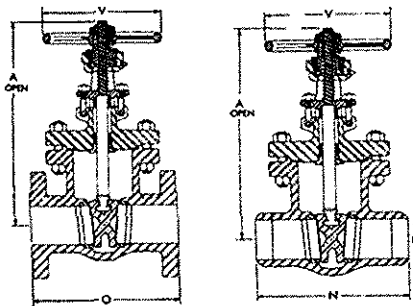

CAST STEEL GATE VALVES

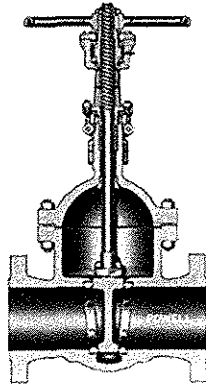

Fig.3003
Flanged
Fig. 3003WE-Welding
Sizes, 14" through 42"
Above 30" data on Request

FEATURES

- Solid Wedges are accurately guided to the seating surfaces. Flexible wedge can be furnished when ordered.
- Stellite faced Seat Rings are welded into the body. This provides a positive no-leak seal of the ring in the valve body.
- Lubricant fitting is provided to permit stem bushing lubrication for ease of operation.
- Valves are furnished with a back seat bushing arrangement in the bonnet

ORDERING

- When ordering Butt Welding End valves, specify schedule of pipe end and give complete data concerning style, figure number and contour of weld end

CLASS 300 BOLTED FLANGED YOKE-BONNET OUTSIDE SCREW RISING STEM FLANGED and WELDING ENDS

PRESSURE/TEMPERATURE RATINGS

In accordance with ASME B16.34

MATERIALS

DESCRIPTION	MATERIAL	ASTM Spec.
Handwheel	Malleable Iron	A-47, Grade 32510
Handwheel Key	Steel	A-108, Grade 1015/1025
Handwheel Nut	Malleable Iron	A-47, Grade 32510
Lubricant Fitting	-	Commercial
Stem Bushing	Ductile Ni-Resist	A-439, Type D2
Yokearm Ear Bolts (14" & 16")	Steel	A-307, Grade B
Yokearm Ear Nuts (14" & 16")	Steel	A-563, Grade A or B
Bonnet Studs	Steel	A-193, Grade B7
Bonnet Nuts	Steel	A-194, Grade 2H
Yokearm	Carbon Steel	A-216, Grade WCB
Cap Screws (18"-30")	Steel	A-449
Eyebolts	Steel	A-307, Grade B
Eyebolts Nuts	Steel	A-563, Grade A or B
Gland Flange	Carbon Steel	A-216, Grade WCB
Gland	Steel	A-108, Gr. 1015/1025
Packing	Grafoil	Commercial
Groov-Pins	Steel	Commercial
Packing Washer	Steel	A-108, Gr. 1015/1025
Back Seat Bushing	Stainless Steel	†A-276, Type 410
Bonnet	Carbon Steel	A-216, Grade WCB
Gasket (Double Jacketed)	Soft Iron/Steel*	Commercial
Body	Carbon Steel	A-216, Grade WCB
Body Studs	Steel	A-193, Grade B7
Body Nuts	Steel	A-194, Grade 2H
Oil Seals (18"-30")	-	Commercial
Stem	Stainless Steel	†A-182, Grade F6a
Seat Rings	Steel/Stellite Facing	A-519, Gr. 1015/1025
Wedge	Carbon Steel/13%Chrome Facing	A-216, Grade WCB
Bearing Cap (18"-30")	Steel	A-36
Thrust Bearings (18"-30")	-	Commercial

*Non-Asbestos Insert

†Or Equal

SPECIFICATIONS

- Flanged and Butt Welding End valves have dimensions conform to ASME B16.5, B16.10, B16.25, B16.34 and API 600
- Flanged End valves can be furnished with ring joint flanges

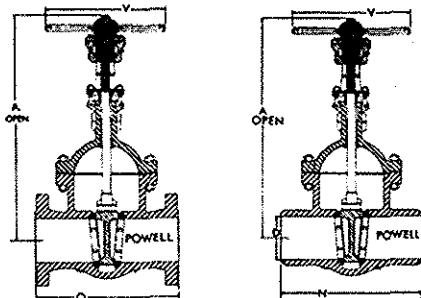

DIMENSIONS (Inches)

Size	14	16	18	20	24	30	36 thru 42
O	30	33	36	39	45	55	Data
N	30	33	36	39	45	55	On
V	26	26	30	30	36	36	Request
A	71	77 1/2	91	99 3/4	122 1/2	145 3/4	
D	To Be Specified						

WEIGHTS (Pounds)

Fig. 3003	2085	2725	3790	4230	6850		
Fig 3003WE	1690	2200	3230	3700	4500		

CAST STEEL GATE VALVES

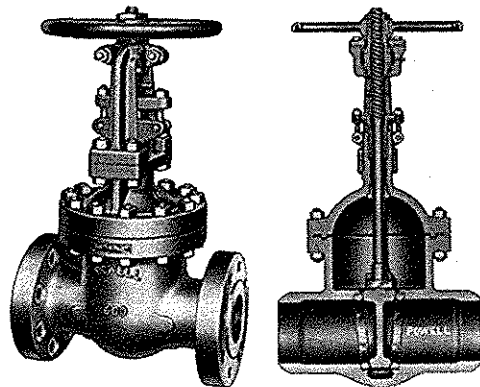

Fig. 6003
Flanged

Fig. 6003WE-Welding
Sizes, 2" through 30"
Above 20" Data on Request

FEATURES

- Solid Wedge is accurately guided to the seating surfaces.
- Stellite faced Seat Rings are welded into the body. This provides a positive no-leak seal of the ring in the valve body.
- Lubricant fitting is provided to permit stem bushing lubrication for ease of operation.
- Valves are furnished with a back seat bushing arrangement in the bonnet.

ORDERING

- When ordering other than standard Butt Welding End valves, specify schedule of pipe and give complete data concerning style, figure number and contour of weld end

CLASS 600 BOLTED FLANGED YOKE-BONNET OUTSIDE SCREW RISING STEM FLANGED and WELDING ENDS

PRESSURE/TEMPERATURE RATINGS
In accordance with ASME B16.34

MATERIALS

DESCRIPTION	MATERIAL	ASTM Spec.
Handwheel Nut	Malleable Iron	A-47, Grade 32510
Handwheel	Malleable Iron	A-47, Grade 32510
Handwheel Key	Steel	A-108, Grade 1015/1025
Lubricant Fitting	-	Commercial
Stem Bushing	Ductile Ni-Resist	A-439, Type D2
Yokearm Ear Bolts (2" & 4")	Steel	A-307, Grade B
Yokearm Ear Nuts (2" & 4")	Steel	A-563, Grade A or B
Eyebolts	Steel	A-307, Grade B
Eyebolts Nuts	Steel	A-563, Grade A or B
Packing	Grafoil	Commercial
Yokearm	Carbon Steel	A-216, Grade WCB
Gland Flange	Carbon Steel	A-216, Grade WCB
Gland	Steel	A-108, Gr. 1015/1025
Groov-Pins	Steel	Commercial
Bonnet Nuts	Steel	A-194, Grade 2H
Bonnet Studs	Steel	A-193, Grade B7
Packing Washer	Steel	A-108, Gr. 1015/1025
Back Seat Bushing	Stainless Steel	† A-276, Type 410
Bonnet	Carbon Steel	A-216, Grade WCB
Gasket (Double Jacketed)	Soft Iron/Steel*	Commercial
Body Nuts	Steel	A-194, Grade 2H
Body Studs	Steel	A-193, Grade B7
Stem	Stainless Steel	† A-182, Grade F6a
Solid Wedge (2"-6")	Stainless Steel	A-217, Grade CA15
(8"- 20")	Carbon Steel/13% Chrome Facing	A-216, Grade WCB
Cap Screws (6"-20")	Steel	A-449
Bearing Cap (6"-20")	Steel	A-36
Oil Seals (6"- 20")	-	Commercial
Thrust Bearings (6"-20")	-	Commercial
Seat Ring	Steel/Stellite Facing	A-519, Gr. 1015/1025
Body	Carbon Steel	A-216, Grade WCB

*Non-Asbestos Insert
†Or Equal

SPECIFICATIONS

- Flanged and Butt Welding End valves conform to ASME B16.5, B16.10, B16.25, B16.34 and API 600
- Flanged End valves can be furnished with ring joint flanges

DIMENSIONS (Inches)

Size	2	2 1/2	3	4	6	8	10	12	14	16	18	20	24 thru 30
O	11 1/2	13	14	17	22	26	31	33	35	39	43	47	Data
N	11 1/2	13	14	17	22	26	31	33	35	39	43	47	On
A	19 1/2	22 1/2	25 3/4	30 3/4	42 1/2	52	61	71	74 1/2	90 3/4	94	99 1/4	Request
V	9	10	12	14	22	22	26	30	30	36	36	36	
D	To Be Specified												

WEIGHTS (Pounds)

Fig. 6003	110	150	200	320	720	1070	1780	2260	3050	4350	5550		
Fig. 6003WE	85	130	160	270	590	970	1520	1880	2560	3720	5000		

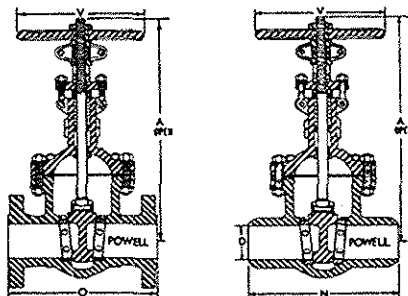

CAST STEEL GATE VALVES

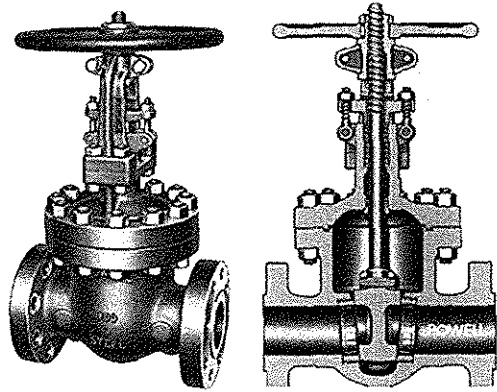

Fig. 9003
Flanged
Fig. 9003WE-Welding
Sizes, 3" through 24"
Above 20" Data on Request

FEATURES

- Solid Wedge is accurately guided to the seating surfaces.
- Lubricant fitting is provided to permit ease of operation of valve
- Lantern rings, when ordered, can be substituted for condensing chambers
- Valves are furnished with a back seat bushing arrangement in the bonnet.

ORDERING

- When ordering Butt Welding End valves, specify schedule of pipe end and give complete data concerning style, figure number and contour of weld ends

CLASS 900 BOLTED FLANGED YOKE-BONNET OUTSIDE SCREW RISING STEM FLANGED and WELDING ENDS

PRESSURE/TEMPERATURE RATINGS

In accordance with ASME B16.34

MATERIALS

DESCRIPTION	MATERIAL	ASTM Spec.
Stem Busing Nut	Malleable Iron	A-47, Grade 32510
Handwheel (3"-8")	Malleable Iron	A-47, Grade 32510
(10"-18")	Ductile Iron	A-445
Handwheel Key	Steel	A-108 Grade 1015/1025
Lubricant Fitting	-	Commercial
Stem Bushing	Bronze	B505 Alloy 95400
Oil Seals (6"-18")	-	Commercial
Bearing (6"-18")	-	Commercial
Yokearm Ear Bolts & Nuts (3"-4")	Steel	A-307, Grade B
Yokearm	Carbon Steel	A-216, Grade WCB
Eyebolts & Nuts	Steel	A-307, Grade B
Gland	Steel	A-108, Gr. 1015/1025
Gland Flange	Carbon Steel	A-216, Grade WCB
Packing	Grafoil	Commercial
Groov-Pins	Steel	Commercial
Bonnet Nuts	Steel	A-194, Grade 2H
Bonnet Studs	Steel	A-193, Grade B7
Packing Washer	Steel	A-108, Gr. 1015/1025
Back Seat Bushing	Stainless Steel	† A-276, Type 410
Bonnet	Carbon Steel	A-216, Grade WCB
Gasket	Spiral Wound	Commercial
Body Nuts	Steel	A-194, Grade 2H
Body Studs	Steel	A-193, Grade B7
Stem	Stainless Steel	† A-182, Grade F6a
Seat Ring	Stainless Steel	A-519, Gr. 1015/1025
Cap Screws (6"-18")	Steel	A-449
Bearing Cap	Steel	A-36
Solid Wedge (3"-4")	Stainless Steel	A-217, Grade CA15
(6"- 18")	Carbon Steel/13%	A-216, Grade WCB
	Chrome Facing	
Body	Carbon Steel	A-216, Grade WCB

†Or Equal

SPECIFICATIONS

- Flanged and Butt Welding End valves conform to ASME B16.5, B16.10, B16.25, B16.34 and API 600
- Flanged End valves can be furnished with ring joint flanges

DIMENSIONS (Inches)

Size		3	4	6	8	10	12	14	16	18	20	24
O	1500 Class	15	18	24	29	33	38	40 1/2	44 1/2	48		Data
N	Valves are	15	18	24	29	33	38	40 1/2	44 1/2	48		On
A	regularly	28 1/4	32 1/2	46 1/4	51	63	73 1/2	80 3/8	83 7/8	97		Request
V	supplied for											
	900 Class	14	17	22	26	30	30	30	36	36		
	Gate Valves in											
	sizes below 3											
	inches											

D TO BE SPECIFIED

WEIGHTS (Pounds)

Fig. 9003	280	450	1050	1320	2340	3400	4250	4900
Fig. 9003WE	240	380	910	1100	2190	3110	4050	

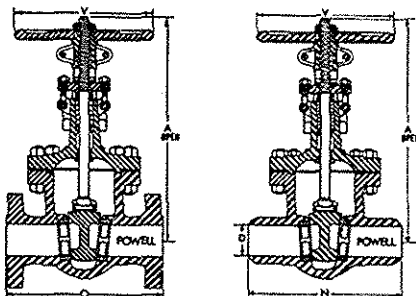

CAST STEEL GATE VALVES

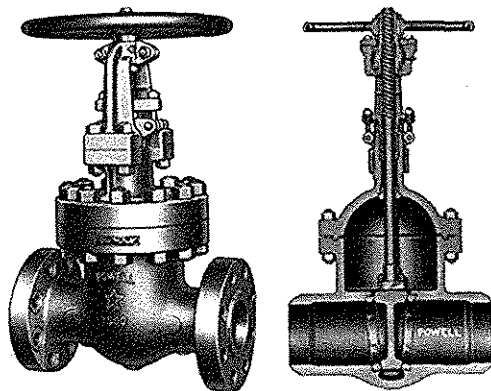

Fig. 1303

Flanged

Fig. 1303WE-Welding

Sizes, 2" through 24"

Above 12" Data on Request

FEATURES

- Solid Wedge are accurately guided to the seating surfaces.
- Lubricant fitting is provided to permit ease of operation of valve
- Lantern rings, when ordered, can be substituted for condensing chambers
- Valves are furnished with a back seat arrangement in the bonnet.

ORDERING

- When ordering Butt Welding End valves, specify schedule of tubing or pipe end and give complete data concerning style, figure number and contour of weld ends

CLASS 1500 BOLTED FLANGED YOKE-BONNET OUTSIDE SCREW RISING STEM FLANGED and WELDING ENDS

PRESSURE/TEMPERATURE RATINGS

In accordance with ASME B16.34

MATERIALS

DESCRIPTION	MATERIAL	ASTM Spec.
Stem Bushing Nut	Malleable Iron	A-47, Grade 32510
Handwheel (2"-4")	Malleable Iron	A-47, Grade 32510
(6"-12")	Ductile Iron	A-445
Handwheel Key	Steel	A-108, Gr. 1015/1025
Lubricant Fitting	-	Commercial
Stem Bushing	Bronze	B505 Alloy 95400
Yokearm Ear Bolts & Nuts (2"-4")	Steel	A-307, Grade B
Eyebolts & Nuts	Steel	A-307, Grade B
Packing	Grafoil	Commercial
Yokearm	Carbon Steel	A-216, Grade WCB
Gland Flange	Carbon Steel	A-216, Grade WCB
Gland	Steel	A-108, Gr. 1015/1025
Groov-Pins	Steel	Commercial
Bonnet Nuts	Steel	A-194, Grade 2H
Bonnet Studs	Steel	A-193, Grade B7
Packing Washer	Steel	A-108, Gr. 1015/1025
Back Seat Bushing	Stainless Steel	†A-276, Type 410
Bonnet	Carbon Steel	A-216, Grade WCB
Gasket	Spiral Wound	Commercial
Body Nuts	Steel	A-194, Grade 2H
Body Studs	Steel	A-193, Grade B7
Stem	Stainless Steel	†A-182, Grade F6a
Solid Wedge (2"-4")	Stainless Steel	A-217, Grade CA15
(6"-12")	Carbon Steel 13% Chrome Facing	A-216, Grade WCB
Cap Screws (6"-12")	Steel	A-449
Bearing Cap (6"-12")	Steel	A-36
Oil Seals (6"-12")	Steel	Commercial
Bearings (6"-12")	-	Commercial
Seat Ring	Steel/Stellite Facing	A-519, Gr. 1015/1025
Body	Carbon Steel	A-216, Grade WCB
†Or Equal		

SPECIFICATIONS

- Flanged and Butt Welding End valves conform to ASME B16.5, B16.10, B16.25, B16.34 and API 600
- Flanged End valves can be furnished with ring joint flanges

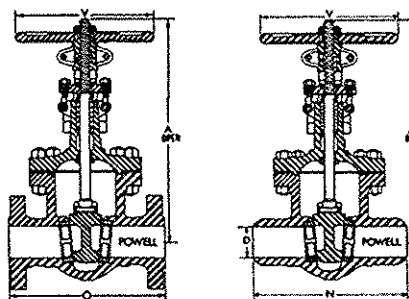

DIMENSIONS (Inches)

Size	2	2 1/2	3	4	6	8	10	12	14 thru 24
O	14 1/2	16 1/2	18 1/2	21 1/2	27 3/4	32 3/4	39	44 1/2	Data
N	14 1/2	16 1/2	18 1/2	21 1/2	27 3/4	32 3/4	39	44 1/2	On
A	24	27 5/8	30 1/2	35 5/8	47	56 1/2	68 1/4	80 1/2	Request
V	12	15	16	18	26	30	36	36	
D	To Be Specified								

WEIGHTS (Pounds)

Fig. 1303	225	350	460	670	1400	2500	5200	5500	
Fig. 1303WE	180	300	390	550	1230	2200	5100	5340	

CAST STEEL GATE VALVES

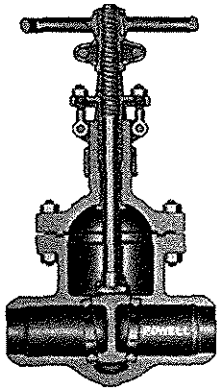

Fig. 25003
Flanged
Fig. 25003 WE-Welding
Sizes, 2" through 8"

FEATURES

- Solid Wedge are accurately guided to the seating surfaces.
- Lubricant fitting is provided to permit ease of operation of valve
- Lantern rings, when ordered, can be substituted for condensing chambers
- Valves are furnished with a back seat arrangement in the bonnet.

ORDERING

- When ordering Butt Welding End valves, specify schedule of tubing or pipe end and give complete data concerning style, figure number and contour of weld ends

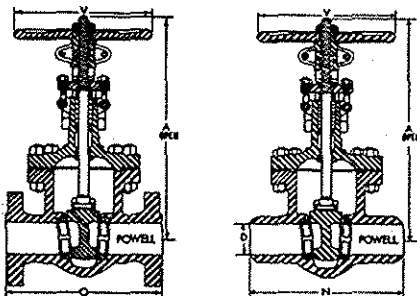

CLASS 2500

BOLTED FLANGED YOKE-BONNET OUTSIDE SCREW RISING STEM FLANGED and WELDING ENDS

PRESSURE/TEMPERATURE RATINGS
In accordance with ASME B16.34

MATERIALS

DESCRIPTION	MATERIAL	ASTM Spec.
Stem Busing Nut	Malleable Iron	A-47, Grade 32510
Handwheel	Malleable Iron	A-47, Grade 32510
Handwheel Key	Steel	A-108, Grade 1015/1025
Lubricant Fitting	-	Commercial
Stem Bushing	Bronze	B505 Alloy 95400
Yokearm Ear Bolts & Nuts (2"- 4")	Steel	A-307, Grade B
Eyebolts & Nuts	Steel	A-307, Grade B
Packing	Grafoil	Commercial
Yokearm	Carbon Steel	A-216, Grade WCB
Gland Flange	Carbon Steel	A-216, Grade WCB
Gland	Steel	A-108, Gr. 1015/1025
Groov-Pin	Steel	Commercial
Bonnet Nuts	Steel	A-194, Grade 2H
Bonnet Studs	Steel	A-193, Grade B7
Packing Washer	Steel	A-108, Gr. 1015/1025
Back Seat Bushing	Stainless Steel	† A-276, Type 410
Bonnet	Carbon Steel	A-216, Grade WCB
Gasket	Spiral Wound	Commercial
Body Nuts	Steel	A-194, Grade 2H
Body Studs	Steel	A-193, Grade B7
Stem	Stainless Steel	† A-182, Grade F6a
Solid Wedge (2"-4")	Stainless Steel	A-217, Grade CA15
(6"-8")	Carbon Steel 13% Chrome Facing	A-216, Grade WCB
Cap Screws (6"-8")	Steel	A-449
Bearing Cap (6"-8")	Steel	A-36
Oil Seal (6"-8")	-	Commercial
Bearings (6"-8")	-	Commercial
Seat Ring	Steel/Stellite Facing	A-519, Gr. 1015/1025
Body	Carbon Steel	A-216, Grade WCB

†Or Equal

SPECIFICATIONS

- Flanged and Butt Welding End valves conform to ASME B16.5, B16.10, B16.25, B16.34 and API 600
- Flanged End valves can be furnished with ring joint flanges

DIMENSIONS (Inches)

Size	2	2 1/2	3	4	6	8
O	17 3/4	20	22 3/4	26 1/2	36	40 1/4
N	17 3/4	20	22 3/4	26 1/2	36	40 1/4
A	26	30	32	37	49	59
V	16	18	22	26	30	30
D	To Be Specified					

WEIGHTS (Pounds)

Fig. 25003	230	400	740	1840	3460
Fig. 25003WE			423		

CAST STEEL GLOBE and ANGLE VALVES

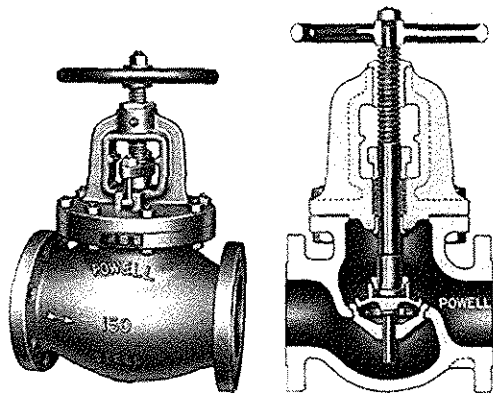

Fig. 1531
Flanged

Fig. 1531 WE-Welding
Globe Valve
Sizes, 2" through 20"
Above 12" Data on Request

Fig. 1533-Flanged
Fig. 1533 WE-Welding
Angle Valve
Sizes, 2" through 12"

FEATURES

- Discs are retained to the stem by a disc locknut and are fully guided. The spindle on the under side of the disc is guided through a bridge cast integral with the seat, assuring better alignment and uniform seating at all times
- Valves are furnished with a back seat arrangement in the bonnet

CLASS 150 BOLTED FLANGED BONNET FLANGED and WELDING ENDS

PRESSURE/TEMPERATURE RATINGS
In accordance with ASME B16.34

MATERIALS

DESCRIPTION	MATERIAL	ASTM Spec.
Handwheel Nut	Steel	A-563, Grade A or B
Handwheel	Malleable Iron	A-47, Grade 32510
Upper Bushing	Ductile Ni-Resist	A-439, Type D2C
Bushing Set Screw	Steel	A-108, Grade 1015/1025
Gland Bolts & Nuts	Steel	A-307, Grade B
Gland	Steel	A-108, Gr. 1015/1025
Gland Flange	Steel	Commercial
Packing Washer	Steel	A-108, Grade 1015/1025
Bonnet	Carbon Steel	A-216, Grade WCB
Packing	Grafoil	Commercial
Body Nuts	Steel	A-194, Grade 2H
Body Studs	Steel	A-193, Grade B7
Gasket (Corrugated)	Stainless Steel/Graphite Coated	Commercial
Back Seat Bushing	Stainless Steel	† A-276, Type 410
Stem	Stainless Steel	† A-276, Type 410
Disc Nut	Stainless Steel	† A-217, Grade CA15
Disc (2"-6")	Stainless Steel	A-217, Grade CA15
(8"-12")	Carbon Steel/13% Chrome Facing	A-216, Grade WCB
Seat Ring	Stainless Steel/ Stellite Facing	A-217, Grade CA15
Body	Carbon Steel	A-216, Grade WCB

†Or Equal

SPECIFICATIONS

- Flanged and Butt Welding End Globe and Angle valves have dimensions in accordance with ASME B16.5, B16.10, B16.25 and B16.34

ORDERING

- When ordering other than standard Butt Welding End valves, specify schedule of tubing or pipe and give complete data concerning style, figure number and contour of weld ends

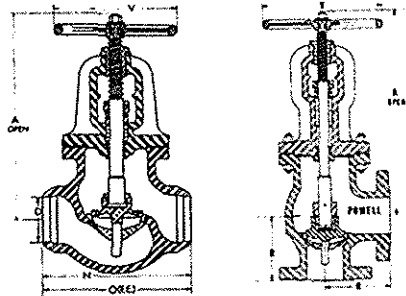

DIMENSIONS (Inches)

Size	2	2 1/2	3	4	6	8	10	12	14 thru 20
O	8	8 1/2	9 1/2	11 1/2	16	19 1/2	24 1/2	27 1/2	Data
R (F.E.)	4	4 1/4	4 3/4	5 3/4	8	9 3/4	12 1/4	13 3/4	On
N	8	8 1/2	9 1/2	11 1/2	16	19 1/2	24 1/2	27 1/2	Request
R.(W.E.)	4	4 1/4	4 3/4	5 3/4	8	9 3/4	12 1/4	13 3/4	
V	8	8	9	10	12	16	18	22	
A	12 1/2	14	15 1/2	18 1/2	21 1/2	24 1/2	29 1/2	32 3/4	
D	2.07	2.50	3.07	4.03	6.07	7.98	10.02	12.00	

WEIGHTS (Pounds)

Fig. 1531	51	65	86	133	245	430	730	810
Fig. 1531WE	40	52	73	120	211	381	680	710

CAST STEEL GLOBE and ANGLE VALVES

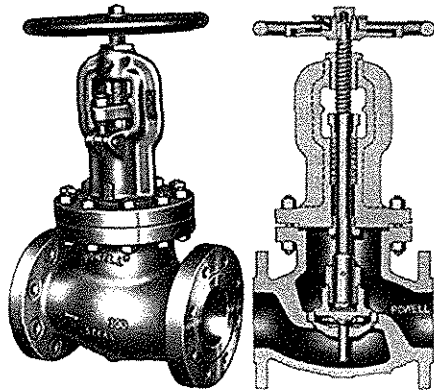

Fig. 3031

Flanged

Fig. 3031 WE-Welding
Globe Valve

Sizes, 2" through 24"
Above 12" Data on Request

Fig. 3033

Flanged

Fig. 3033 WE-Welding
Angle Valve

Sizes, 2" through 8"

FEATURES

- Discs are retained to the stem by a disc locknut and are fully guided. The spindle on the under side of the disc is guided through a bridge cast integral with the seat, assuring better alignment and uniform seating at all times
- Valves are furnished with a back seat arrangement in the bonnet

CLASS 300 BOLTED FLANGED BONNET FLANGED and WELDING ENDS

PRESSURE/TEMPERATURE RATINGS
In accordance with ASME B16.34

MATERIALS

DESCRIPTION	MATERIAL	ASTM Spec.
Handwheel Nut	Steel	A-563, Grade A or B
Handwheel	Malleable Iron	A-47, Grade 32510
Upper Bushing	Ductile Ni-Resist	A-439, Type D2C
Bushing Set Screw	Steel	Commercial
Eyebolts & Nuts	Steel	A-307, Grade B
Gland	Steel	A-108, Gr. 1015/1025
Gland Flange	Steel	Commercial
Packing Washer	Steel	A-108, Grade 1015/1025
Bonnet	Carbon Steel	A-216, Grade WCB
Packing	Grafoil	Commercial
Body Nuts	Steel	A-194, Grade 2H
Body Studs	Steel	A-193, Grade B7
Gasket (Double Jacketed)	Soft Iron/Steel*	Commercial
Back Seat Bushing	Stainless Steel	† A-276, Type 410
Stem	Stainless Steel	† A-276, Type 410
Disc Nut	Stainless Steel	† A-217, Grade CA15
Disc (2"-6")	Stainless Steel	A-217, Grade CA15
Disc (8"-12")	Carbon Steel/13% Chrome	A-216, Grade WCB
	Facing	
Seat Ring	Stainless Steel/ Stellite	A-217, Grade CA15
	Facing	
Body	Carbon Steel	A-216, Grade WCB
Thrust Washer	Nitalloy	AMS 6470E

*Non-Asbestos Insert

†Or Equal

SPECIFICATIONS

- Flanged and Butt Welding End Globe and Angle valves have dimensions in accordance with ASME B16.5, B16.10, B16.25 and B16.34

ORDERING

- When ordering other than standard Butt Welding End valves, specify schedule of pipe and give complete data concerning style, figure number and contour of weld ends

DIMENSIONS (Inches)

Size	2	2 1/2	3	4	6	8	10	12	14 thru 24
O	10 1/2	11 1/2	12 1/2	14	17 1/2	22	24 1/2	28	Data On Request
R (F.E.)	5 1/4	5 3/4	6 1/4	7	8 3/4	11	—	—	
N	10 1/2	11 1/2	12 1/2	14	17 1/2	22	24 1/2	28	
R.(W.E.)	5 1/4	5 3/4	6 1/4	7	8 3/4	11	—	—	
V	8	9	10	13	18	22	26*	30*	
A	18	19 1/2	20 3/4	24 1/2	31 1/4	37 3/4	44 1/2	47 3/8	
D	2.07	2.47	3.07	4.03	6.07	7.98	10.02	12.00	

WEIGHTS (Pounds)

Fig. 3031.....	60	93	113	173	325	481	686	837
Fig. 3031WE..	47	74	85	132	267	411	605	680

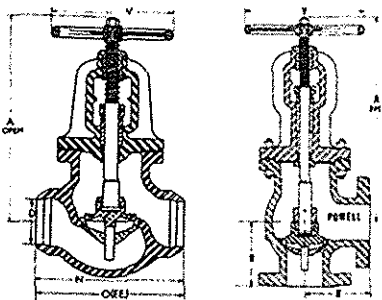

CAST STEEL GLOBE and ANGLE VALVES

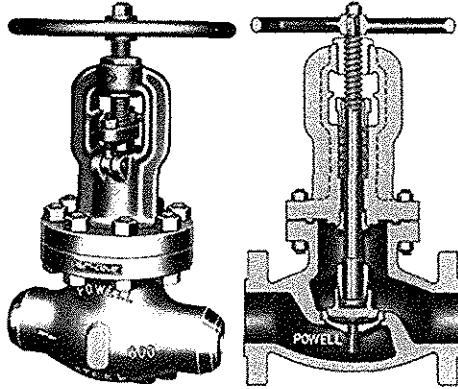

Fig. 6031

Flanged

Fig. 6031 WE-Welding
Globe Valve

Sizes, 2" through 16"

Above 12" Data on Request

Fig. 6033 - Flanged

Fig. 6033 WE-Welding
Angle Valve

Sizes, 3" through 8"

ORDERING

•When ordering other than standard Butt Welding End valves, specify schedule of pipe and give complete data concerning style, figure number and contour of weld ends

CLASS 600 BOLTED FLANGED BONNET FLANGED and WELDING ENDS

PRESSURE/TEMPERATURE RATINGS

In accordance with ASME B16.34

MATERIALS

DESCRIPTION	MATERIAL	ASTM Spec.
Handwheel (2 1/2" and larger)	Carbon Steel	A-216, Grade WCB
(2" and smaller)	Malleable Iron	A-47, Grade 32510
Handwheel Nut	Steel	A-307, Grade B
Handwheel Retainer Plate (2 1/2" & larger)	Steel	A-36
Gasket (Double Jacketed)	Soft Iron/Steel*	Commercial
Packing	Grafoil	Commercial
Crossarm (2 1/2" & larger)	Carbon Steel	A-216, Grade WCB
Back Seat Bushing	Stainless Steel	† A-276, Type 410
Body Studs	Steel	A-193, Grade B7
Body Nuts	Steel	A-194, Grade 2H
Gland	Steel	A-108, Grade 1015/1025
Gland Flange	Carbon Steel	A-216, Grade WCB
Eyebolts & Nuts	Steel	A-307, Grade B
Groov-Pins	Steel	Commercial
Body	Carbon Steel	A-216, Grade WCB
Bonnet	Carbon Steel	A-216, Grade WCB
Disc (2" & 4")	Stainless Steel	A-217, Grade CA15
(6" - 12")	Carbon Steel /13% Chrome Facing	A-216, Grade WCB
Seat Ring	Stainless Steel/Stellite Facing	A-217, Grade CA15
Stem	Stainless Steel	† A-276, Type 410
Packing Washer	Steel	A-108, Grade 1015/1025
Upper Bonnet Bushing	Bronze	B505 Alloy 95400
Disc Nut	Stainless Steel	† A-276, Type 410
Thrust Washer	Nitralloy	AMS 6470-E

*Non-Asbestos Insert

†Or Equal

SPECIFICATIONS

*Flanged and Butt Welding End Globe and Angle valves have dimensions in accordance with ASME B16.5, B16.10, B16.25 and B16.34

FEATURES

*Disc are retained to the stem by a disc locknut and are fully guided

*Valves are furnished with a back seat arrangement in the bonnet

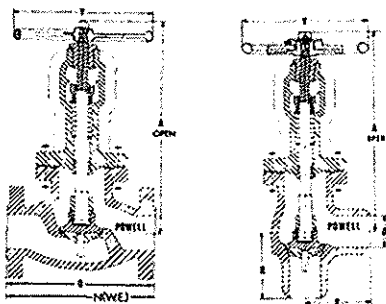

DIMENSIONS (Inches)

Size	2	2 1/2	3	4	6	8	10	12	14	16
O	11 1/2	13	14	17	22	26	31	33		
R.(F.E.)	-	-	7	8 1/2	11	13	-	-		
N	11 1/2	13	14	17	22	26	31	33		
R.(W.E.)	-	-	7	8 1/2	11	13	-	-		Data On Request
V	9	12†	12†	16†	20†	20†	26†	30†		
A	18 3/4	21 1/4	22 1/2	27 1/4	33 3/4	46 1/2	49	53		
D	1.94	2.32	2.90	3.83		Schedule 80				

†Hammerblow Handwheel

WEIGHTS (Pounds)

6031	94	130	166	315	630	1130	2100	2780
6031WE	75	115	140	240	480	1070	1800	

CAST STEEL GLOBE and ANGLE VALVES

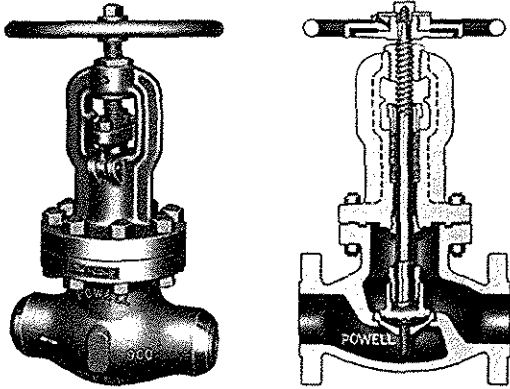

Fig. 9031

Flanged

Fig. 9031 WE-Welding
Globe Valve

Sizes, 3" through 16"
Above 12" Data on Request

Fig. 9033-Flanged

Fig. 9033 WE-Welding
Angle Valve

Sizes, 3" through 6"

FEATURES

- Discs are retained to the stem by a disc locknut and are fully guided. The spindle on the under side of the disc is guided through a bridge cast integral with the seat, assuring better alignment and uniform seating at all times
- Valves are furnished with a back seat arrangement in the bonnet
- Valves have Hammerblow Handwheel

CLASS 900 BOLTED FLANGED BONNET FLANGED and WELDING ENDS

PRESSURE/TEMPERATURE RATINGS

In accordance with ASME B16.34

MATERIALS

DESCRIPTION	MATERIAL	ASTM Spec.
Handwheel	Carbon Steel	A-216, Grade WCB
Handwheel Nut	Steel	A-307, Grade B
Handwheel Retainer Plate	Steel	A-36
Gasket	Spiral Wound	Commercial
Packing	Grafoil	Commercial
Crossarm	Carbon Steel	A-216, Grade WCB
Back Seat Bushing	Stainless Steel	† A-276, Type 410
Body Studs	Steel	A-193, Grade B7
Body Nuts	Steel	A-194, Grade 2H
Gland	Steel	A-108, Gr. 1015/1025
Gland Flange	Carbon Steel	A-216, Grade WCB
Eyebolts & Nuts	Steel	A-307, Grade B
Groov-Pins	Steel	Commercial
Body	Carbon Steel	A-216, Grade WCB
Bonnet	Carbon Steel	A-216, Grade WCB
Disc (3" & 4")	Stainless Steel	A-276, Type 410
(6" - 12")	Carbon Steel /13% Chrome Facing	A-216, Grade WCB
Seat Ring	Stainless Steel/Stellite Facing	A-217, Grade CA15
Stem	Stainless Steel	† A-276, Type 410
Packing Washer	Steel	A-108, Gr. 1015/1025
Upper Bonnet Bushing	Bronze	B505 Alloy 95400
Disc Nut	Stainless Steel	† A-276, Type 410
Thrust Washer	Nitralloy	AMS 6470-E

† Or Equal

SPECIFICATIONS

- Flanged and Butt Welding End Globe and Angle valves have dimensions in accordance with ASME B16.5, B16.10, 16.25 and 16.34.

ORDERING

- Flanged and Butt Welding End Angle valves are supplied on special order
- When ordering Butt Welding End valves, specify schedule of tubing or pipe end and give complete data concerning style, figure number and contour of weld ends

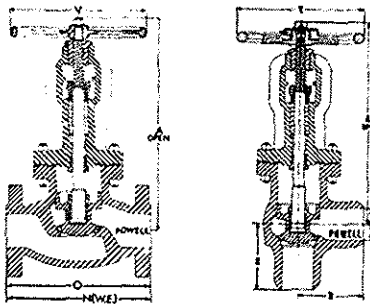

DIMENSIONS (Inches)

Size		3	4	6	8	10	12	14	16
O	1500 Class Valves	15	18	24	29	33	38		
R.(F.E.)	are regularly	7 1/2	9	12	-	-	-	DATA	
N	supplied for 900	15	18	24	29	33	38	ON	
R.(W.E.)	Class Globe and	7 1/2	9	12	-	-	-		
A	Angle Valves in	26 3/4	30 1/2	40 1/2	54	66 1/2	81	REQUEST	
V	Sizes below	14	16	20	26	30	36		
D	3 inches	To Be Specified							

WEIGHTS (Pounds)

Fig. 9031	280	445		
Fig. 9033WE	210	360	915	1760

CAST STEEL GLOBE VALVES

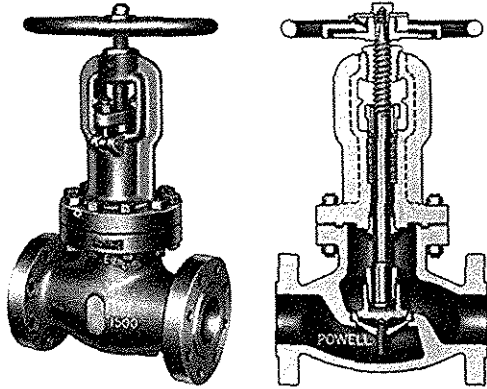

Fig. 1331
Flanged
Fig. 1331 WE - Welding
Sizes, 2" through 16"
Above 6" Data on Request

FEATURES

- Discs are retained to the stem by a disc locknut and are fully guided. The spindle on the under side of the disc is guided through a bridge cast integral with the seat, assuring better alignment and uniform seating at all times
- Valves are furnished with a back seat arrangement in the bonnet

CLASS 1500 BOLTED FLANGED BONNET FLANGED and WELDING ENDS

PRESSURE/TEMPERATURE RATINGS
In accordance with ASME B16.34

MATERIALS

DESCRIPTION	MATERIAL	ASTM Spec.
Handwheel (2 1/2"-6")	Carbon Steel	A-216, Grade WCB
Handwheel (2")	Malleable Iron	A-47, Grade 32510
Handwheel Nut	Steel	A-307, Grade B
Handwheel Retainer Plate (2 1/2"-6")	Steel	A-36
Gasket	Spiral Wound	Commercial
Packing	Grafoil	Commercial
Crossarm (2 1/2"-6)	Carbon Steel	A-216, Grade WCB
Back Seat Bushing	Stainless Steel	† A-276, Type 410
Body Studs	Steel	A-193, Grade B7
Body Nuts	Steel	A-194, Grade 2H
Gland	Steel	A-108, Grade 1015/1025
Gland Flange	Carbon Steel	A-216, Grade WCB
Eyebolts & Nuts	Steel	A-307, Grade B
Groov-Pins	Steel	Commercial
Body	Carbon Steel	A-216, Grade WCB
Bonnet	Carbon Steel	A-216, Grade WCB
Disc	Stainless Steel	† A-276, Type 410
Seat Ring	Stainless Steel/ Stellite Facing	A-217, Grade CA15
Stem	Stainless Steel	† A-276, Type 410
Packing Washer	Steel	A-108, Grade 1015/1025
Upper Bonnet Bushing	Bronze	B505 Alloy 95400
Disc Nut	Stainless Steel	† A-276, Type 410
Thrust Washer	Nitralloy	AMS 6470-E

†Or Equal

SPECIFICATIONS

- Flanged and Butt Welding End Globe valves have dimensions in accordance with ASME B16.5, B16.10, 16.25 and 16.34.

ORDERING

- When ordering Butt Welding End valves, specify schedule of tubing or pipe end and give complete data concerning style, figure number and contour of weld ends

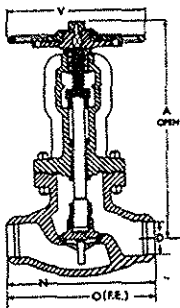

DIMENSIONS (Inches)

Size	2	2 1/2	3	4	6	8 thru 16
O	14 1/2	16 1/2	18 1/2	21 1/2	27 3/4	Data
N	14 1/2	16 1/2	18 1/2	21 1/2	27 3/4	On
A	22 1/2	26 1/2	27 3/4	36	50	Request
V	12	14*	16*	20*	30*	
D	To Be Specified					

* Hammerblow Handwheel

WEIGHTS (Pounds)

Fig. 1331	195	255	350	685	1300	
Fig. 1331WE	170	255	300	550	1380	

CAST STEEL NON-RETURN GLOBE and ANGLE VALVES

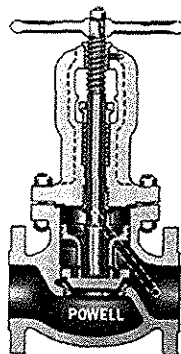

Fig. 3084
Flanged
Fig. 3084 WE-Welding
Globe Valve
Sizes, 3" through 12"

Fig. 3086-Flanged
Fig. 3086 WE-Welding
Angle Valve
Sizes, 3" through 12"

FEATURES

- Globe and Angle Non-Return valves are required when two or more boilers are connected in a single mainheader. They close automatically, instantly cutting out the boiler connected in the battery when the pressure within this particular boiler suddenly drops below that in the header line. Non-Return valves must be mounted with the stem in vertical position so that the disc is free to close by gravity
- Equalizer-helps reduce pressure drop and prevents wear producing disc vibrations

CLASS 300 BOLTED FLANGED BONNET FLANGED and WELDING ENDS

PRESSURE/TEMPERATURE RATINGS
In accordance with ASME B16.34

MATERIALS

DESCRIPTION	MATERIAL	ASTM Spec.
Body	Carbon Steel	A-216 Gr. WCB
Bonnet	Carbon Steel	A-216, Grade WCB
Disc (3" & 4")	Stainless Steel	A-217 Gr. CA15
Disc (6" - 12")	Carbon Steel/ 13% Chrome Facing	A-216 Grade WCB
Seat Ring	Steel/Stellite Facing	A-106, Grade B
Stem	Stainless Steel	† A-276, Type 410
Gland	Steel	A-108, Grade 1015/1025
Gland Flange	Carbon Steel	A-216, Grade WCB
Upper Bonnet Bushing	Bronze	B505 Alloy 95400
Handwheel	Malleable Iron	A-47, Grade 32510
Body Studs	Steel	A-193, Grade B7
Body Nuts	Steel	A-194, Grade 2H
Packing	Grafoil	Commercial
Gasket (Double Jacketed)	Soft Iron/Steel*	Commercial
Packing Washer	Steel	A-108, Grade 1015/1025
Equalizer Pipe Bend	Steel	A-106, Grade B
Groov-Pins	Steel	Commercial
Eyebolts & Nuts	Steel	A-307, Grade B
Handwheel Key (10" & larger)	Steel	A-108, Grade 1015/1025
Back Seat Bushing	Stainless Steel	† A-276, Type 410
Handwheel Nut	Steel	A-307, Grade B

* Non Asbestos Insert

† Or Equal

SPECIFICATIONS

- Flanged and Welding End valves have dimensions in accordance with ASME B16.5, B16.10 and B16.25

ORDERING

- Flanged and Welding End Globe and Angle valves are available on order

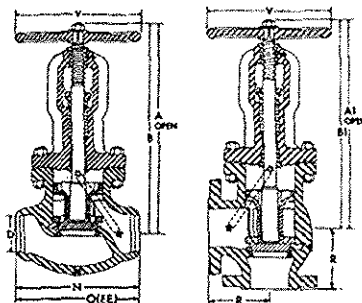

DIMENSIONS (Inches)

Size	3	4	6	8	10	12
O	12 1/2	14	17 1/2	22	24 1/2	28
R	6 1/4	7	8 3/4	11	12 1/4	14
N	12 1/2	14	17 1/2	22	24 1/2	28
V	10	13	22	26	26*	30*
A-Open	20 1/4	22 1/2	27 3/4	32 3/4	37 1/4	43 1/2
B-Closed	19 1/8	20 3/4	24 7/8	29 1/2	33 1/8	39
A1-Open	18 7/8	21 1/2	24 3/4	27 1/2	34 7/8	41 1/4
B1-Closed	16 7/8	19 3/8	22 1/2	25	31 1/2	37 3/4
D	3.07	4.03	6.07	7.98	10.02	To Be Specified

*Hammerblow Handwheel

WEIGHTS (Pounds)

Fig. 3084	140	230	415	725	1360	1880
Fig. 3084WE	115	170	330	605		

CAST STEEL NON-RETURN GLOBE and ANGLE VALVES

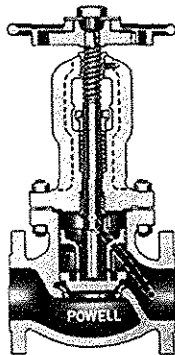

Fig. 6084

Flanged
Fig. 6084 WE-Welding
Globe Valve
Sizes, 3" through 12"

Fig. 6086-Flanged
Fig. 6086 WE-Welding
Angle Valve
Sizes, 3" through 12"

FEATURES

- Globe and Angle Non-Return valves are required when two or more boilers are connected in a single mainheader. They close automatically, instantly cutting out the boiler connected in the battery when the pressure within this particular boiler suddenly drops below that in the header line. Non-Return valves must be mounted with the stem in vertical position so that the disc is free to close by gravity
- Equalizer-helps reduce pressure drop and prevents wear producing disc vibrations

CLASS 600 BOLTED FLANGED BONNET FLANGED and WELDING ENDS

PRESSURE/TEMPERATURE RATINGS
In accordance with ASME B16.34

MATERIALS

Description	Material	ASTM Spec.
Handwheel	Carbon Steel	A-216, Grade WCB
Handwheel Retaining Plate	Steel	A-36
Gasket (Double Jacketed)	Soft Iron/Steel*	Commercial
Packing	Grafoil	Commercial
Crossarm	Carbon Steel	A-216, Grade WCB
Back Seat Bushing	Stainless Steel	† A-276, Type 410
Body Studs	Steel	A-193, Grade B7
Body Nuts	Steel	A-194, Grade 2H
Equalizer Pipe Bend	Steel	A-106, Grade B
Gland	Steel	Commercial
Gland Flange	Carbon Steel	A-216, Grade WCB
Pipe Plug	Steel	Commercial
Eyebolts & Nuts	Steel	A-307, Grade B
Groov-Pins	Steel	Commercial
Body	Carbon Steel	A-216, Grade WCB
Bonnet	Carbon Steel	A-216, Grade WCB
Disc	Steel/Stellite Facing	A-516, Grade 70
Seat Ring	Steel/Stellite Facing	A-106, Grade B
Stem	Stainless Steel	† A-276, Type 410
Handwheel Nut	Steel	A-307, Grade B
Packing Washer	Steel	A-108, Grade 1020
Upper Bonnet Bushing	Bronze	B505 Alloy 95400
Handwheel Key	Steel	A-108, Grade 1020

* Non Asbestos Insert
† Or Equal

SPECIFICATIONS

- Flanged and Welding End valves have dimensions in accordance with ASME B16.5, B16.10 and B16.25

ORDERING

- Flanged and Welding End Globe and Angle valves are available on order

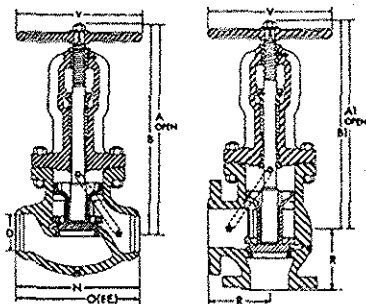

DIMENSIONS (Inches)

Size	3	4	6	8	10	12
O	14	17	22	26	31	33
R	7	8 1/2	11	13	15 1/2	16 1/2
N	14	17	22	26	31	33
V	12	16	20*	20*	26*	30*
A-Open	21 3/8	24 1/2	31 3/8	36	42 3/4	48
B-Closed	20 1/4	22 3/4	28 1/2	32 3/4	-	-
A1-Open	19 3/4	23 3/8	29 1/4	33 5/8	39 3/4	44
B1-Closed	17 7/8	21 5/8	26 3/8	30 3/8	-	-
D	Schedule 80					

* Hammerblow Handwheel

WEIGHTS (Pounds)

Fig. 6084	165	320	705	900	1780	2800
Fig. 6084WE	145			890	1800	

CAST STEEL SWING CHECK VALVES

CLASS 150 BOLTED FLANGED CAP FLANGED and WELDING ENDS

PRESSURE/TEMPERATURE RATINGS
In accordance with ASME B16.34

MATERIALS

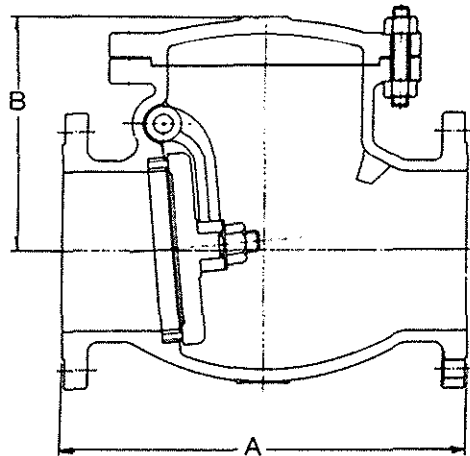

Fig. 1561
Flanged
Fig. 1561 WE-Welding
Sizes, 1" through 36"

DESCRIPTION	MATERIAL	ASTM Spec.
Body	Carbon Steel	A216 Gr. WCB
Cover	Carbon Steel	A216 Gr. WCB
Disc	Stainless Steel	A217 Gr. CA-15
Hinge	Carbon Steel	A216 Gr. WCB
Hinge Pin	Stainless Steel	A182 Gr. F6a
Seat Ring	Steel/Stellite Facing	A-519, Grade 1015/1025
Plug	Carbon Steel	A108 Gr. 1045
Cover Bolt	Carbon Steel	A193 Gr. B7
Cover Nut	Carbon Steel	A194 Gr. 2H
Disc Nut	Carbon Steel	A563 Gr. B
Washer	Stainless Steel	A276 Type 304
Eye Bolt	Carbon Steel	A307 Gr. B
Name Plate	Stainless Steel	A240 Gr. 304
Gasket	Soft Metal	Corrugated Type

SPECIFICATIONS

- Flanged and Welding End valves have dimensions in accordance with ASME B16.5, B16.10 and B16.25
- End flanges are furnished with 1/16" raised face; special end flange facings can be supplied on special order

FEATURES

- These valves can be used in horizontal or vertical position; however, when installed in vertical line flow must be upward with the pressure under the disc

ORDERING

- When ordering other than standard Butt Welding End valves, specify schedule of pipe and give complete data concerning style, figure number and contour of weld ends

DIMENSIONS (Inches)

Size	1	1 1/2	2	2 1/2	3	4	6	8	10	12	14	16	18	20	24	30	36
A. FE	5	6 1/2	8	8 1/2	9 1/2	11 1/2	14	19 1/2	24 1/2	27 1/2	31	34	38 1/2	38 1/2	51	60	77
A. WE	5	6 1/2	8	8 1/2	9 1/2	11 1/2	14	19 1/2	24 1/2	27 1/2	31	34	38 1/2	38 1/2	51	60	77
B.	3 3/8	4 1/2	5 1/8	5 1/2	6 1/8	7 1/4	11 1/2	13 1/8	14 5/8	16 3/8	19 1/4	20 1/2	22	23 1/4	27 5/8	34 1/4	41 1/2
Wt. (Lbs) F.E	9.5	25	42	53	71	113	177	320	481	695	960	1250	1550	1950	3440	4965	

CAST STEEL SWING CHECK VALVES

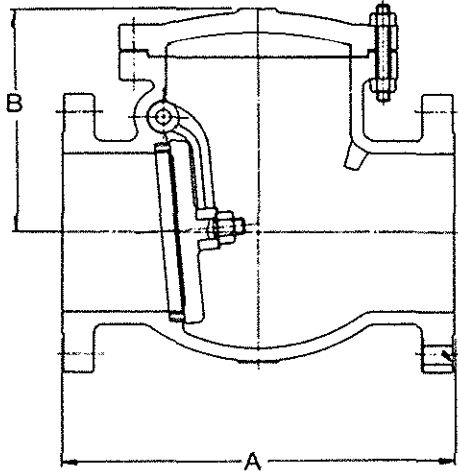

Fig. 3061
Flanged
Fig. 3061 WE-Welding
Sizes, 1" through 36"
Above 24" Data on Request

FEATURES

- These valves can be used in horizontal or vertical position; however, when installed in vertical line flow must be upward with the pressure under the disc

CLASS 300 BOLTED FLANGED CAP FLANGED and WELDING ENDS

PRESSURE/TEMPERATURE RATINGS
In accordance with ASME B16.34

MATERIALS

DESCRIPTION	MATERIAL	ASTM Spec.
Body	Carbon Steel	A216 Gr. WCB
Cover	Carbon Steel	A216 Gr. WCB
Disc	Stainless Steel	A217 Gr. CA-15
Hinge	Carbon Steel	A216 Gr. WCB
Hinge Pin	Stainless Steel	A182 Gr. F6a
Seat Ring	Steel/Stellite Facing	A-519, Grade 1015/1025
Plug	Carbon Steel	A108 Gr. 1045
Cover Bolt	Carbon Steel	A193 Gr. B7
Cover Nut	Carbon Steel	A194 Gr. 2H
Disc Nut	Carbon Steel	A563 Gr. B
Washer	Stainless Steel	A276 Type 304
Eye Bolt	Carbon Steel	A307 Gr. B
Name Plate	Stainless Steel	A240 Gr. 304
Gasket (Double Jacketed)	Soft Iron/Steel*	Commercial

*Non Asbestos Insert

SPECIFICATIONS

- Flanged and Welding End valves have dimensions in accordance with ASME B16.5, B16.10 and B16.25
- End flanges are furnished with 1/16" raised face; special end flange facings can be supplied on special order

ORDERING

- When ordering other than standard Butt Welding End valves, specify schedule of pipe and give complete data concerning style, figure number and contour of weld ends

DIMENSIONS (Inches)

Size	1	1 1/2	2	2 1/2	3	4	6	8	10	12	14	16	18	20	24	30	36
A. F.E.	8 1/2	9 1/2	10 1/2	11 1/2	12 1/2	14	17 1/2	21	24 1/2	28	33	34	38 1/2	40	53		
A. W.E.	8 1/2	9 1/2	10 1/2	11 1/2	12 1/2	14	17 1/2	21	24 1/2	28	33	34	38 1/2	40	53		DATA ON REQUEST
B.	3 3/8	5 1/2	5 7/8	6 1/2	7 1/4	8 1/4	12	14 1/4	16 1/8	18	20 1/4	22 1/4	28 1/8	29 3/8	31 1/8		
Wt. (Lbs) F.E.	10	36	56	75	105	155	265	420	600	955	1570	1960	2210	2610	4280		

CAST STEEL SWING CHECK VALVES

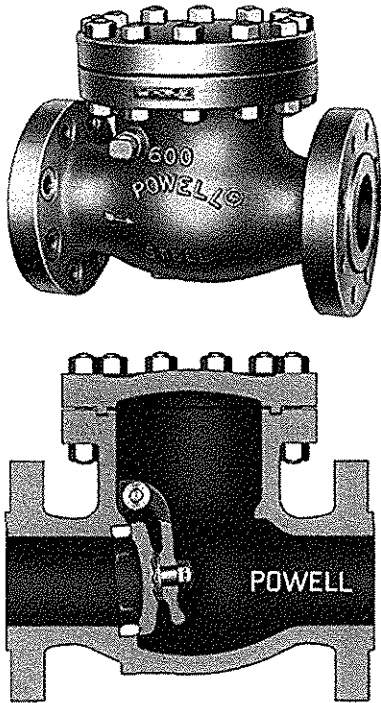

Fig. 6061

Flanged

Fig. 6061 WE-Welding
Sizes, 1" through 30"
Above 12" Data on Request

FEATURES

- These valves can be used in horizontal or vertical position; however, when installed in vertical line flow must be upward with the pressure under the disc

CLASS 600 BOLTED FLANGED CAP FLANGED and WELDING ENDS

PRESSURE/TEMPERATURE RATINGS

In accordance with ASME B16.34

MATERIALS

DESCRIPTION	MATERIAL	ASTM Spec.
Body	Carbon Steel	A-216, Grade WCB
Cap	Carbon Steel	A-515, Grade 70
Seat Ring	Steel/Stellite Facing	A-519, Grade 1015/1025
Disc	Carbon Steel/13% Chrome Facing	† A-216, Grade WCB
Carrier	Stainless Steel	A-217, Grade CA15
Disc Nut	Stainless Steel	† A-582, Type 303
Carrier Pin	Stainless Steel	† A-276, Type 410
Gasket (Double Jacketed)	Soft Iron/Steel*	Commercial
Body Studs	Steel	A-193, Grade B7
Body Nuts	Steel	A-194, Grade 2H
Disc Nut Pin	Stainless Steel	Commercial
Seat Ring (1" - 1 1/2")	Stainless Steel	A-312, Type 316

*Non Asbestos Insert

† Or Equal

SPECIFICATIONS

- Flanged and Welding End valves have dimensions in accordance with ASME B16.5, B16.10 and B16.25
- End flanges are furnished with 1/4" raised face; special end flanges are available on special order

ORDERING

- When ordering other than standard Butt Welding End valves, specify schedule of pipe and give complete data concerning style, figure number and contour of weld ends

DIMENSIONS (Inches)

Size	1	1 1/2	2	2 1/2	3	4	6	8	10	12	14 thru 30
O	8 1/2	9 1/2	11 1/2	13	14	17	22	26	31	33	Data
N	8 1/2	9 1/2	11 1/2	13	14	17	22	26	31	33	On
A	4 7/8	6 3/8	6 3/4	7 11/16	8 7/16	10 1/8	12 15/16	14 3/4	17 13/16	20 1/8	Request
D	Schedule 80										

WEIGHTS (Pounds)

Fig 6061	16	48	70	100	140	225	550	870	1300	1960
Fig. 6061WE	15	36	50	80	110	200	425	670		

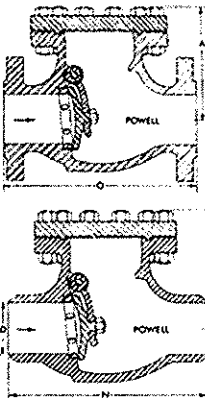

CAST STEEL SWING CHECK VALVES

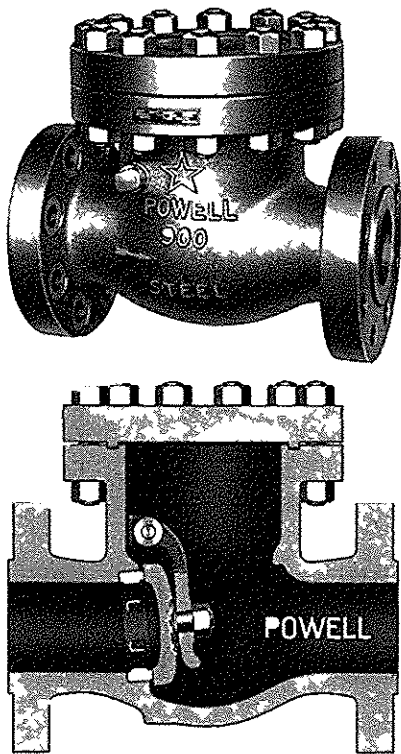

Fig 9061

Flanged
Fig 9061 WE Welding
Sizes 3 through 24
Above 8 data on Request

FEATURES

These valves can be used in horizontal or vertical position however when installed in vertical line flow must be upward with the pressure under the disc.

CLASS 900 BOLTED FLANGED CAP FLANGED and WELDING ENDS

PRESSURE/TEMPERATURE RATINGS
In accordance with ASME B16.34

DESCRIPTION	MATERIAL	ASIM Spec
Body	Carbon Steel	A 216 Grade WCB
Cap	Carbon Steel	A 516 Grade 70
Seat Ring	Steel/Stellite Facing	A 516 Grade 101J/102J
Disc	Carbon Steel 13 / Chromo Facing	† A 216 Grade WCB
Carrier Holder	Stainless Steel	A 217 Grade CA15
Disc Nut	Stainless Steel	† A 382 Type 303
Carrier Pin	Stainless Steel	† A 276 Type 410
Gasket	Spiral Wound	Commercial
Body Studs	Steel	A 193 Grade B7
Body Nuts	Steel	A 14 Grade 2H
Disc Nut Pin	Stainless Steel	Commercial
Plug	Stainless Steel	† A 276 Type 410

† Or equal

SPECIFICATIONS

Flanged and Welding End valves have dimensions in accordance with ASME B16.3 B16.10 and B16.23
End flanges are furnished with 1/4 raised face special end flanges are available on special order

ORDERING

When ordering other than standard Butt Welding End valves specify schedule of pipe and give complete data concerning style figure number and contour of weld ends

DIMENSIONS (Inches)

	3	4	6	8	10th	24
SONA D	1.00 Class VI p, led f VI	1.00 Class VI p, led f VI	1.00 Class VI p, led f VI	1.00 Class VI p, led f VI	1.00 Class VI p, led f VI	1.00 Class VI p, led f VI
Weight	200	300	840	1300		
Weight WE	160	270	500	1000		

WEIGHTS (Pounds)

Fig 9061	200	300	840	1300
Fig 9061WE	160	270	500	1000

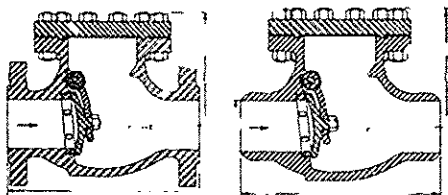

CAST STEEL SWING CHECK VALVES

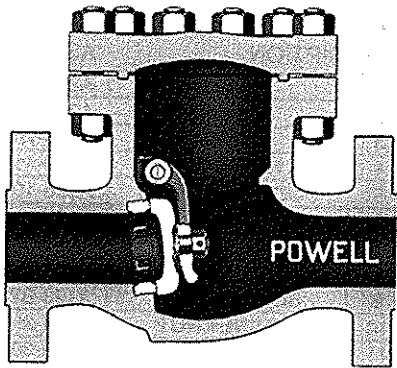

Fig. 1361

Flanged

Fig. 1361 WE-Welding
Sizes, 2" through 12"

FEATURES

- These valves can be used in horizontal or vertical position; however, when installed in vertical line flow must be upward with the pressure under the disc

CLASS 1500 BOLTED FLANGED CAP FLANGED and WELDING ENDS

PRESSURE/TEMPERATURE RATINGS
In accordance with ASME B16.34

MATERIALS

DESCRIPTION	MATERIAL	ASTM Spec.
Body	Carbon Steel	A-216, Grade WCB
Cap	Carbon Steel	A-515, Grade 70
Seat Ring	Steel/Stellite Facing	A-519, Grade 1015/1025
Disc	Carbon Steel 13% Chrome Facing	†A-216, Grade WCB
Carrier Holder	Stainless Steel	A-217, Grade CA15
Disc Nut	Stainless Steel	A-582, Type 303
Carrier Pin	Stainless Steel	A-276, Type 410
Gasket	Spiral Wound	Commercial
Body Studs	Steel	A-193, Grade B7
Body Nuts	Steel	A-194, Grade 2H
Disc Nut Pin	Stainless Steel	Commercial
Plug	Stainless Steel	†A-276, Type 410

† Or Equal

SPECIFICATIONS

- Flanged and Welding End valves have dimensions in accordance with ASME B16.5, B16.10 and B16.25
- End flanges are furnished with 1/4" raised face; special end flanges are available on special order

ORDERING

- When ordering other than standard Butt Welding End valves, specify schedule of pipe and give complete data concerning style, figure number and contour of weld ends

DIMENSIONS (Inches)

Size	2	2 1/2	3	4	6	8	10	12
O	14 1/2	16 1/2	18 1/2	21 1/2	27 3/4	32 3/4	Data	
N	14 1/2	16 1/2	18 1/2	21 1/2	27 3/4	32 3/4	On	
A	9 3/16	10 3/8	11 3/8	13 5/16	16 3/8	20 13/16	Request	
D	To Be Specified							

WEIGHTS (Pounds)

Fig. 1361	195	250	310	550	1000	2200	
Fig. 1361WE	135	200	230	430	800	1900	

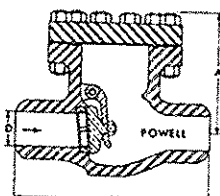
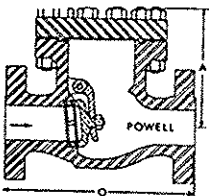

CAST STEEL TILTING DISC CHECK VALVES

CLASS 150-1500

**BOLTED FLANGED CAP
FLANGED and WELDING ENDS**

PRESSURE/TEMPERATURE RATINGS
In accordance with ASME B16.34

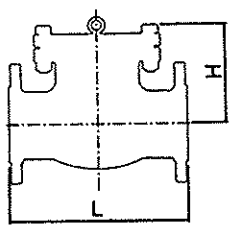
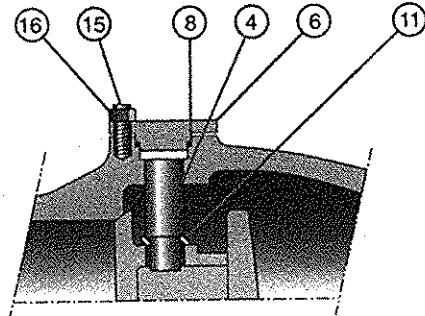
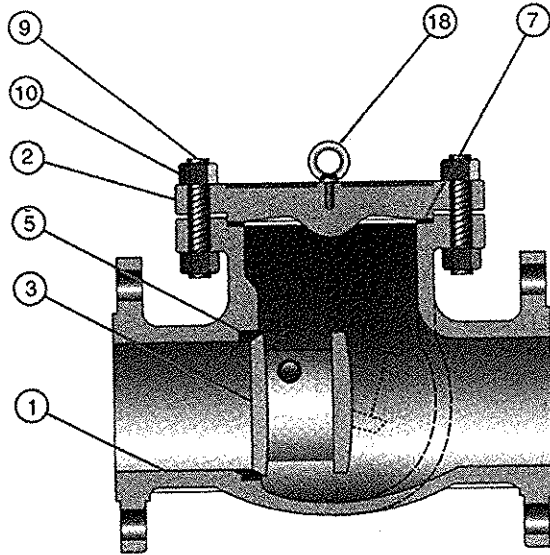

MATERIALS (Carbon Steel)

DESCRIPTION	ASTM Spec.
1 BODY	A216-WCB
2 BONNET	A216-WCB
3 DISC	A216-WCB+410
4 HINGE PIN	A479-410
5 BODY SEAT RING	A576-1020+410
6 COVER	A105
7 GASKET	GRAPHITE
8 COVER GASKET	GRAPHITE
9 BONNET BOLT	A193-B7
10 BONNET NUT	A194-2H
11 BUSHING	A479-304
15 COVER BOLT	A193-B7
16 COVER NUT	A194-2H
18 EYE BOLT	A307-B

SPECIFICATIONS

- Flanged and Butt Welding End valves conform to ANSI B16.5, B16.10, B16.25, B16.34 and API 600

DIMENSIONS (Inches)

CLASS 150 Fig. 1595FE, BWE

Size	2	2 1/2	3	4	6	8	10	12	14	16	18	20	24
L Face-to-Face FE, WE	8	8 1/2	9 1/2	11 1/2	14	19 1/2	24 1/2	27 1/2	31	34	38 1/2	38 1/2	51
H Center-to-Top	6 1/4	6 3/4	7 1/8	7 1/2	9	11	13 3/8	15 1/8	15 3/4	17 3/4	19	20 5/8	23 1/2

CLASS 300 Fig. 3095FE, BWE

Size	2	2 1/2	3	4	6	8	10	12	14	16	18	20	24
L Face-to-Face FE, WE	10 1/2	11 1/2	12 1/2	14	17 1/2	21	24 1/2	28	33	34	38 1/2	40	53
H Center-to-Top	6 1/4	7 1/8	7 1/2	8 1/2	10 1/2	12 5/8	15	16 1/2	18 7/8	20 1/2	21 1/4	22 3/4	27 1/8

CLASS 600 Fig. 6095FE, BWE

Size	2	2 1/2	3	4	6	8	10	12	14	16	18	20	24
L Face-to-Face FE, WE	11 1/2	13	14	17	22	26	31	33	35	39	43	47	55
H Center-to-Top	7 1/8	7 1/2	8 1/4	10 3/4	13 3/4	16 1/8	17 3/4	18 1/4	20 1/8	21	26	28 1/2	32 1/4

CLASS 900 Fig. 9095FE, BWE

Size	2	3	4	6	8
L Face-to-Face FE, WE	14 1/2	15	18	24	29
H Center-to-Top 10 1/2	10 1/2	11 3/8	12	15 1/8	18 1/8

CLASS 1500 Fig. 1395FE, BWE

Size	2	3	4	6	8
L Face-to-Face FE, WE	14 1/2	18 1/2	21 1/2	27 3/4	32 3/4
H Center-to-Top	10 1/2	11 5/8	14	18 1/4	21 1/4

CAST STEEL PRESSURE SEAL VALVES

Gate • Globe • Angle • "Y" • Non-Return • Check

PRESSURE SEAL BONNET
WELDING ENDS

PRESSURE/TEMPERATURE RATINGS
In accordance with ASME B16.34

CLASS 600-2500

POWELL PRESSURE SEAL VALVES ARE AVAILABLE IN THE FOLLOWING SIZES

GATE VALVES

Fig. No.	Class - Inches	2 1/2	3	4	6	8	10	12	14	16	18	20	24
16003WE	600 Gate	•	•	•	•	•	•	•	•	•+	•+	•+	•+
19003WE	900 Gate	•	•	•	•	•	•	•	•	•+	•+	•+	•+
11303WE	1500 Gate	•	•	•	•	•	•	•	•	•+	•+	•+	•+
120003WE	2000 Gate										•+	•+	•+
125003WE	2500 Gate	•	•	•	•	•	•	•	•+	•+	•+	•+	•+

VENTURI VALVES ARE AVAILABLE - SIZES 6" and LARGER

+Handwheel actuated valve not available - Consult Powell Engineering for proper selection of Manual Gear or Power Actuator

• Indicates sizes in which valves are available

GLOBE • ANGLE • "Y" • NON-RETURN • CHECK • VALVES

Fig. No.	Class and Type-Inches	2 1/2	3	4	6	8	10	12	14	16	18	20
16031WE	600 Globe		Y	Y	U	U	Yu+	Y+	Y+	Y+	Y+	Y+
16033WE	600 Angle			•	•							
16084WE	600 Globe Non-Return		Y	Y	U	U	Yu+	Y+	Y+	Y+	Y+	Y*
16086WE	600 Angle Non-Return		•	•	•							
16065WE	600 Lift Check		Y	Y	U	U	Yu	Y	Y	Y	Y	Y
16067WE	600 Angle Lift Check		•	•	•							
19031WE	900 Globe		Y	Y	U	U	Yu+	Yu+	Y+	Y+	Y+	Y+
19033WE	900 Angle		•	•	•	•	•+	•+				
19084WE	900 Globe Non-Return		Y	Y	U	U	Yu+	Yu+	Y+	Y+	Y+	Y+
19086WE	900 Angle Non-Return		•	•	•	•	•+	•+				
19065WE	900 Lift Check		Y	Y	U	U	Yu	Yu	Y	Y	Y	Y
19067WE	900 Angle Lift Check		•	•	•	•	•	•				
11331WE	1500 Globe	Y	Y	Y	Yu	Yu+	Yu+	Y+				
11333WE	1500 Angle	•	•	•	•	•+	•+					
11384WE	1500 Globe Non-Return	Y	Y	Y	Yu	Yu+	Yu+	Y+				
11386WE	1500 Angle Non-Return	•	•	•	•	•+	•+					
11365WE	1500 Lift Check	Y	Y	Y	Yu	Yu	Yu	Y				
11367WE	1500 Angle Lift Check	•	•	•	•	•	•	•				
125031WE	2500 Globe	Y	Y	Y	Y	Y+	Y+	Y+	Y+	Y+	Y+	
125033WE	2500 Angle	•	•	•								
125084WE	2500 Globe Non-Return	Y	Y	Y	Y	Y+	Y+	Y+	Y+	Y+	Y+	
125086WE	2500 Angle Non-Return	•	•	•								
125065WE	2500 Lift Check	Y	Y	Y	Y	Y	Y	Y	Y	Y	Y	
125067WE	2500 Angle Lift Check	•	•	•	•	•	•					

+ Handwheel Actuated Valve Not Available - Consult Powell Engineering for proper selection of Manual Gear or Power Actuator

• Indicates sizes in which valves are available

U Upright Design

Y "Y" Design

Yu "Y" Design is standard, Upright Design is available if specified

CAST STEEL PRESSURE SEAL VALVES

Accurately machined Acme threads prolong the life of the stem and bushing.

Tapered roller bearings for ease of operation.

Lifting lugs facilitate handling the valve during erection and maintenance. Also provides means for supporting the weight of the valve.

Swing eyebolts and gland shelves facilitate repacking.

Inner row of studs establish the initial seal of the Pressure Seal Joint.

Outer row of studs secures the yokearm to the body.

The bonnet joint remains tight under all operating conditions as the sealing pressure is always many times greater than the pressure of the fluid in the line, thereby eliminating leakage. The higher the internal pressure, the greater the sealing pressure.

Streamline contour of body simplifies application and reduces cost of insulation, and effects marked savings in space and weight.

Stellite back seat area provides accurate guiding of stem.

Streamlined passage makes possible maximum flow with minimum turbulence.

Stellite faced flexible "H" type wedge prevents sticking due to temperature changes and pipe line stresses.

Seal rings are Stellite faced and securely welded in place.

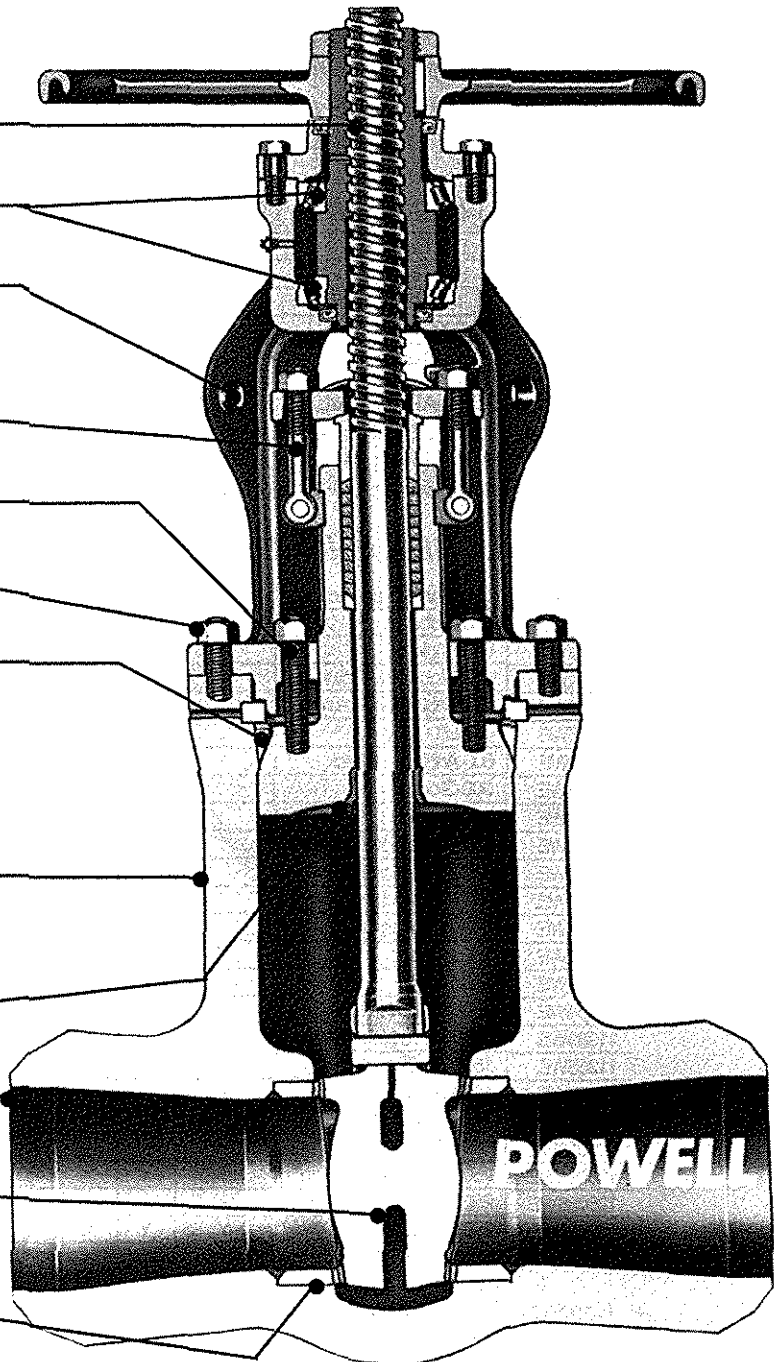

CAST STEEL PRESSURE SEAL VALVES

Gate · Globe · Angle · "Y" · Non-Return · Check

DESIGN AND CONSTRUCTION

Powell Pressure Seal Valves are intended for high pressure, high temperature applications in all types of fluid except where severe coking is a factor.

The design and materials selections provide excellent service in fossil and nuclear steam generating stations, industrial and chemical plants, and refineries.

The Powell design Pressure Seal Valves provide the most efficient flow passage and sealing features possible resulting

in significant weight savings, ease of installation and maintenance features.

Manufacturing and quality assurance procedures include extra controls on dimensional, non-destructive examination and testing of critical areas such as the gasket seating, welding end and stellite seating surfaces.

BODY - Flow areas are designed for minimum turbulence and pressure drop. Casting and forging quality requirements are considered in the design of Powell Pressure Seal Valves.

BONNET - Ample stuffing box and stellite stem guide and back seat shoulder are provided for accurate guiding of the stem and back seating.

WEDGE (Gate Valves) - Flexible wedge design on 4" and larger sizes provide flexibility to prevent sticking. Wedges are stellite faced and have machined guides for control of alignment during valve operation.

DISC (Globe & Check Valves) - Globe and check type discs are accurately fitted and guided to minimize vibration. Seating

surfaces are stellite. One piece stem and disc design are furnished on larger sizes.

SEAT RINGS - Seat rings are stellite faced, accurately fitted and seal welded in place.

YOKE DESIGN - Studs fasten the yoke directly to the valve body. The bolting and internal design features eliminate heavy clamp rings and provide rigidity, accurate alignment of the valve internal parts and operating mechanism. Lifting lugs on large size valves aid in installation and maintenance operation.

STEM - Threads are accurately machined. Packing area is polished to reduce stem friction and packing wear.

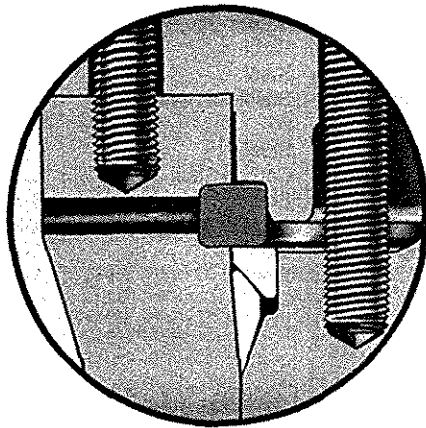

Delta Pressure Seal Design

The Delta Seal Design is used in valves for pressures 2500 pound and higher and services which have drastic temperature variations. This exclusive double gasket design provides three sealing surfaces that contract and expand uniformly with the valve body eliminating body leaks. The 5° seat taper eliminates surface contact and possible damage to the gasket and seating surface of the valve during removal of the gasket. The Delta Seal Gasket can be easily removed for valve maintenance, reducing downtime appreciably. This results in more reliable operation of Powell Pressure Seal Valves.

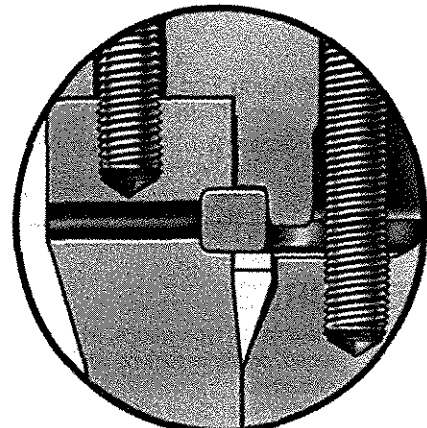

Standard Pressure Seal Design

The segmental thrust rings absorb all the thrust applied by internal pressure. A hardened stainless steel protective ring prevents deformation of the top surface of the soft metallic gasket. The 5° seat eliminates surface contact and possible damage to the gaskets and internal surface of the valve during removal of the gasket. The gasket can be removed freely without damaging the sealing surface of the body. The gasket seating surface in the body may be lapped, if required.

CAST STEEL PRESSURE SEAL GATE VALVES

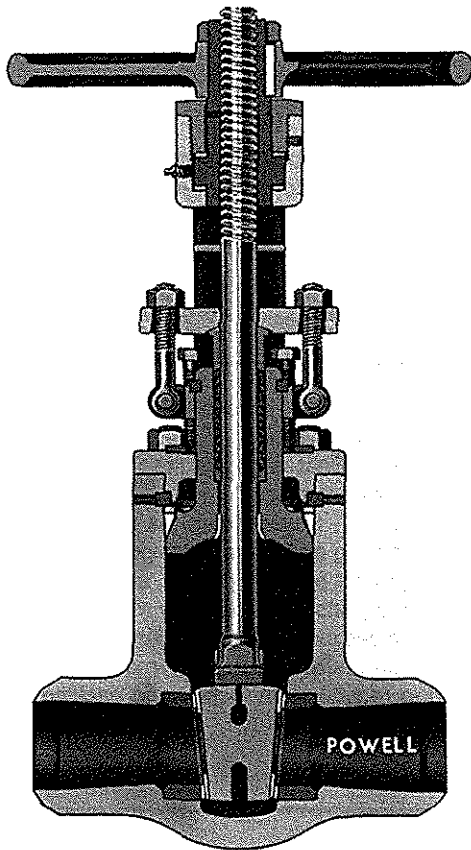

Welding End Pressure Seal Gate Valve
 Sizes, 2 1/2" through 4"

FEATURES

- Flexible "H" type wedge, which is stellite faced, prevents sticking when valves are closed hot
- Stellite faced Seat Rings are accurately machined, pressed and welded in place
- Stellite faced back seat area and stem guide insure tight sealing and accurate guiding of stem
- Yokearm design - studs and nuts hold the yokearm to the body. This eliminates the need of a heavy clamp, and maintains perfect alignment and rigidity of yokearm to the body
- Swing Eyebolts provide easy access to the packing chamber
- Body has a streamlined passage which produces maximum flow with minimum turbulence
- 2 1/2" & 3" Class 900 thru 2500 and 4" Class 1500 & 2500 furnished with Anti-Friction bearings

CLASS 600-2500 SMALL SIZE VALVES PRESSURE SEAL BONNET WELDING ENDS

PRESSURE/TEMPERATURE RATINGS

In accordance with ASME B16.34

MATERIALS

DESCRIPTION	MATERIAL	ASTM Spec.
Body	Carbon Steel	A-216, Grade WCB
Bonnet	Carbon Steel/Stellite Integral Back Seat	A-105
Yokearm	Carbon Steel	A-216, Grade WCB
Stem	Stainless Steel	† A-182, Grade F6a
Wedge	Carbon Steel/Stellite Seat Facing	A-216, Grade WCB
Seat Ring	Steel/Stellite Seat Facing	A-519, Grade 1015/1025
Protective Ring	Stainless Steel	† A-473, Type 416
Yokearm Face Ring	Stainless Steel	† A473, Type 416
Bonnet Take-Up Flange	Chrome Moly Steel	AISI 4140
Split Thrust Ring	Stainless Steel	† A-473, Type 416
Gland	Brass	B-16
Gland Flange	Carbon Steel	A-216, Grade WCB
Stem Bushing	Bronze	B-62
Handwheel	Malleable Iron	A-47, Grade 32510
Key	Steel	A-108, Grade 1015/1025
Stem Bushing Nut	Malleable Iron	A-47, Grade 32510
Gasket	Soft Iron/Steel	
Packing	Grafoil	Commercial
Segmental Thrust Ring	Stainless Steel	† A-473, Type 416
Lubricant Fitting	-	Commercial
Set Screw	Steel	Commercial
Eyebolts & Nuts	Steel	A-307, Grade B
Studs	Steel	A-193, Grade B7
Nuts	Steel	A-194, Grade 2H
Groov-Pins	Steel	Commercial
Bearing Cap Screws	Steel	A-449
Stem Bushing Thrust Washer	Stainless Steel	† A-473, Type 416
Packing Washer	Steel	A-108, Grade 1015/1025
Eyebolt Clamp	Carbon Steel	A-216, Grade WCB
Stem Bushing Locknut	Brass	B-16
Locknut	Carbon Steel	A-216, Grade WCB
Take-Up Cap Screws	Steel	A-193, Grade B7
Bearing Cap	Steel	A-36
Oil Seals	-	Commercial
Bearing	-	Commercial

† Or Equal

SPECIFICATIONS

- 600 class valves have Diameter of bore equivalent to Schedule 80 pipe, and will be furnished unless otherwise specified. Contour of weld ends to be the same as Figs. 2A or 3A, ASME B16.25. Welding Bore can be furnished to meet customer's specifications.
- Nominal pipe size, schedule of pipe, or bore or wall thickness, must be specified on 900 class valves and up, so that valve can be machined to match customer's pipe.
- When backing or chill rings are used, specific details must be given.
- End-to-end dimensions conform to ASME B16.10

CAST STEEL PRESSURE SEAL GATE VALVES

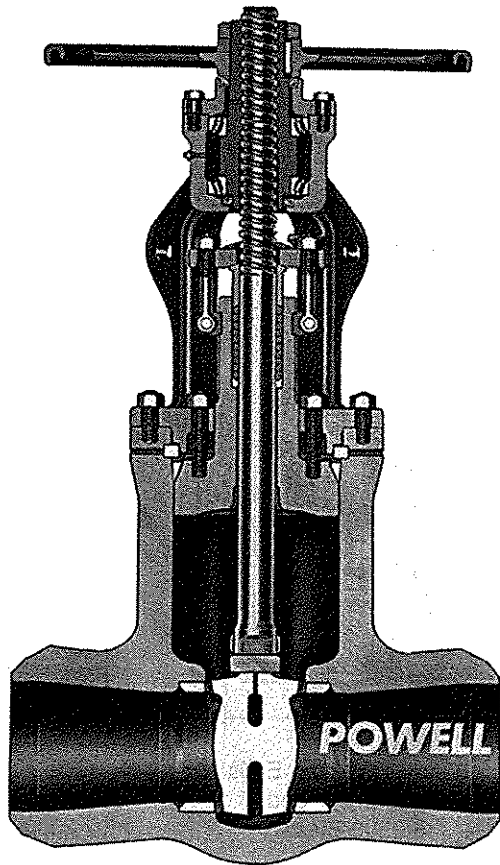

Welding End Pressure Seal
Gate Valve
Sizes, 6" and Larger

FEATURES

- Flexible "H" type wedge, which is stellite faced, prevents sticking when valves are closed hot
- Stellite faced Seat Rings are accurately machined, pressed and welded in place
- Stellite faced back seat area and stem guide insure tight sealing and accurate guiding of stem
- Yokearm design - studs and nuts hold the yokearm to the body. This eliminates the need of a heavy clamp, and maintains perfect alignment and rigidity of yoke to the body
- Swing Eyebolts provide easy access to the packing chamber
- Body has a streamlined passage which produces maximum flow with minimum turbulence
- Lifting Lugs, an exclusive Powell feature, are cast on the yokearm of larger size valves to facilitate handling during erection and in maintenance
- 600 and 900 class valves sizes 18", 20" and 24" are available in forged and cast design

CLASS 600-2500 LARGE SIZE VALVES PRESSURE SEAL BONNET WELDING ENDS

PRESSURE/TEMPERATURE RATINGS

In accordance with ASME B16.34

MATERIALS

DESCRIPTION	MATERIAL	ASTM Spec.
Body	Carbon Steel	A-216, Grade WCB
Bonnet	Carbon Steel/Stellite Integral Back Seat	A-105
Yokearm	Carbon Steel	A-216, Grade WCB
Wedge	Carbon Steel/ Stellite Facing	A-216, Grade WCB
Seat Ring	Steel/Stellite Seat Facing	A-519, Grade 1015/1025
Stem Bushing	Bronze	B-62
Stem Bushing Nut	Malleable Iron	A-47, Grade 32510
Bearing Cap	Steel	A-36
Segmental Thrust Ring	Stainless Steel	† A-473, Type 416
Protective Ring	Stainless Steel	† A-473, Type 416
Stem	Stainless Steel	† A-182, Grade F6a
Packing Washer	Steel	A-108, Grade 1015/1025
Eyebolt Clamp	Carbon Steel	A-216, Grade WCB
Gland	Brass	B-16
Gland Flange	Carbon Steel	A-216, Grade WCB
Gasket	Soft Iron/Steel	
Packing	Grafoil	Commercial
Bearings	-	Commercial
Oil Seals	-	Commercial
Lubricant Fitting	-	Commercial
Studs	Steel	A-193, Grade B7
Nuts	Steel	A-194, Grade 2H
Key	Steel	A-108, Grade 1015/1025
Handwheel	Malleable Iron	A-47, Grade 32510
Bearing Cap Screws	Steel	A-449
Eyebolts & Nuts	Steel	A-307, Grade B
Groov-Pins	Steel	Commercial
Take-Up Cap Screws	Steel	A-193, Grade B7
Bonnet Take-Up Flange	Chrome Moly Steel	† AISI 4140
Split Thrust Ring	Stainless Steel	A-473, Type 416
Bearing Housing	Carbon Steel	A-216, Grade WCB

† Or Equal

SPECIFICATIONS

- 600 class valves have Diameter of bore equivalent to Schedule 80 pipe, and will be furnished unless otherwise specified. Contour of weld ends to be the same as Figs. 2A or 3A, ASME B16.25. Welding Bore can be furnished to meet customer's specifications.
- Nominal pipe size, schedule of pipe, or bore or wall thickness, must be specified on 900 class valves and up, so that valve can be machined to match customer's pipe.
- When backing or chill rings are used, specific details must be given.
- End-to-end dimensions conform to ASME B16.10 (except for 2000 class valves)
- 2500 class valves have Delta Seal Gasket.

CAST STEEL PRESSURE SEAL GATE VALVES

WELDING ENDS

CLASS 600 through 2500

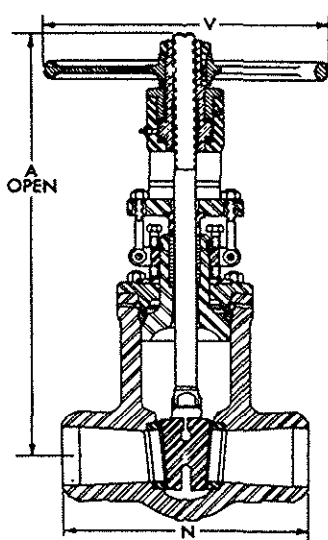

Gate -- Welding Ends
 Sizes, 2 1/2" - 4"
 600 - 1500 Class

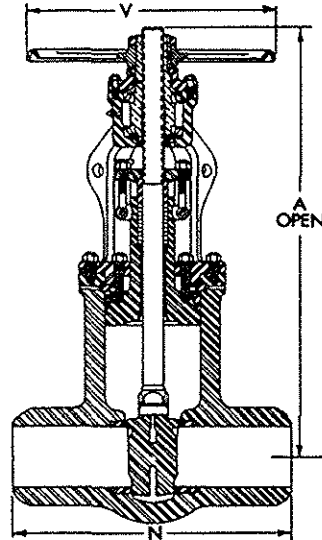

Gate -- Welding Ends
 Sizes, 6" and larger
 600 - 1500 Class

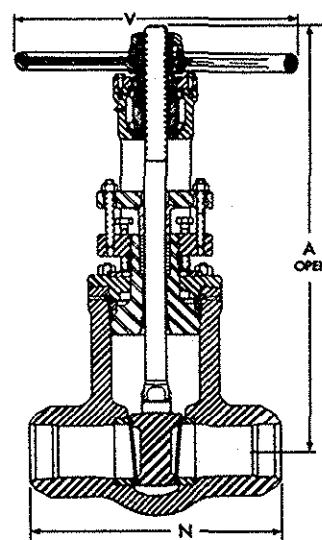

Gate -- Welding Ends
 Sizes, 2 1/2" and 3"
 2500 Class

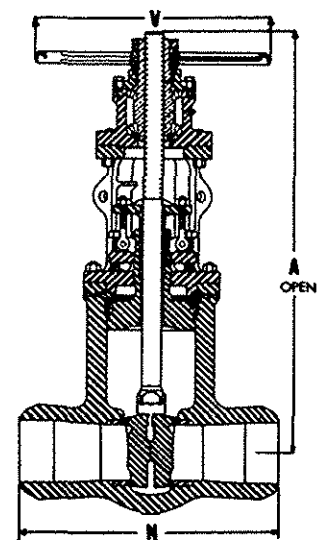

Gate -- Welding Ends
 Sizes, 4" and 18"
 2000 - 2500 Class

DIMENSIONS (Inches)

Size		2 1/2†	3†	4	6	8	10	12	14	16	18	20	22	24	30
600 Class Fig. 16003 WE	N	8 1/2	10	12	18	23	28	32	35	39	43	47	-	55	65
	A	20 7/8	23 5/8	30 3/8	42 3/4	50 1/4	56 1/2	68 5/8	73 3/8	81 7/8*	87 3/4*	94 1/2*	-	109 1/2*	138*
	V	10	10	14	22	22	26	30	30	36	*	*	-	*	*
900 Class Fig. 19003 WE	N	10	12	14	20	26	31	36	39	43	48	52	-	61	-
	A	24 1/8	23	33 1/4	44 3/4	46 7/8	57	65 7/8	72 3/4	80*	87 3/4*	94 1/2*	-	109 1/2*	-
	V	14	10	18	22	26	30	30	30	*	*	*	-	*	-
1500 Class Fig. 11303 WE	N	10	12	16	22	28	34	39	42	47	53	58	64	66	-
	A	24 1/8	25	26 3/4	44 3/8	53 5/8	62 1/4	68	74 1/2	98*	108*	123 1/4*	111*	116*	-
	V	14	14	14	26	30	30	30	36	*	*	*	-	*	-
2000 Class Fig. 120003 WE	N	-	-	-	22	28	34	39	42	47	53	58	64	66	-
	A	-	-	-	44 3/8	53 5/8	62 1/4	68	77 3/8	98*	108*	123 1/4*	111*	116*	-
	V	-	-	-	26	30	30	30	36	*	*	*	-	*	-
2500 Class Fig. 125003 WE	N	13	14 1/2	18	24	30	36	41	44	49	55	62	-	-	-
	A	24 1/8	25	39	43 1/8	53 3/4	63 1/2	67 3/4	90 3/8*	94*	105 5/8*	98 3/4*	-	-	-
	V	14	14	22	26	30	30	36	*	*	*	*	-	-	-

† (900 Class) Size 3" valves have Solid Wedge

† (1500 Class) Size 2 1/2" and 3" valves have Solid Wedge

600 and 900 Class valves size 18", 20" and 24" are also available in forged design

* Handwheel Actuated Valve Not Available - Consult Powell Engineering for proper selection of Manual Gear or Powered Actuator.

CAST STEEL PRESSURE SEAL VENTURI GATE VALVES

WELDING ENDS

CLASS 600 through 2500

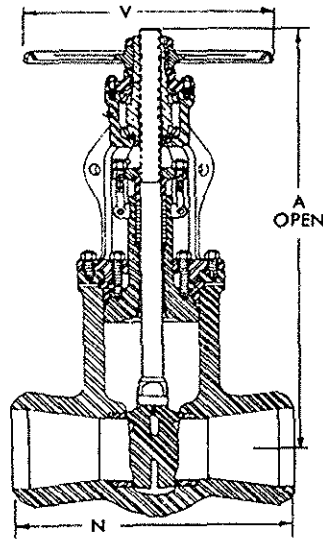

Venturi Gate -- Welding Ends

DIMENSIONS (Inches)

Size		8x6x8	10x8x10	12x10x12	14x12x14	16x14x16	18x16x18	20x18x20	24x20x24	24x22x24
600 Class Fig. 16003 WE	N	18	23	28	32	35	39	43	52	-
	A	42 3/4	50 1/4	56 1/2	68 5/8	73 3/8	81 7/8*	87 3/4*	94 1/2*	-
	V	22	22	26	30	36	*	*	*	-
900 Class Fig. 19003 WE	N	20	26	31	36	39	43	48	52	-
	A	44 3/4	46 7/8	57	65 7/8	72 3/4	73 3/4*	87 3/4*	94 1/2*	-
	V	22	26	30	30	30	*	*	*	-
1500 Class Fig. 11303 WE	N	22	28	34	39	42	47	53	62	64
	A	44 3/8	53 5/8	62 1/4	68	77 3/8	98*	108*	94*	111*
	V	26	30	30	30	36	*	*	*	*
2000 Class Fig. 12003 WE	N	22	28	34	39	42	47	53	62	64
	A	44 3/8	53 5/8	62 1/4	68	77 3/8	98*	108*	98 3/4*	111*
	V	26	30	30	30	36	*	*	*	*
2500 Class Fig. 12503 WE	N	24	30	36	41	44	49	55	62	-
	A	43 1/8	53 3/4	63 1/2	67 3/4	90 3/8*	94*	105 5/8*	98 3/4*	-
	V	26	30	30	36	*	*	*	*	-

* Handwheel Actuated Valve Not Available - Consult Powell Engineering for proper selection of Manual Gear or Powered Actuator

CAST STEEL PRESSURE SEAL "Y" GLOBE VALVES

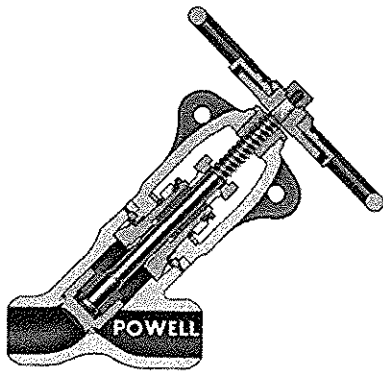

Pressure Seal
"Y" Globe Valve

FEATURES

- Discs are accurately fitted and guided to minimize vibration. Seating surfaces are stellite
- Stellite faced back seat area and stem guide insure tight sealing and accurate guiding of stem
- Yoke design - Studs fasten the yoke directly to the valve body. The bolting and internal design features eliminate heavy clamp rings and provide rigidity, accurate alignment of the valve internal parts and operating mechanism
- Body has a flow area that is designed for minimum turbulence and pressure drop

CLASS 600-2500

PRESSURE SEAL BONNET WELDING ENDS

PRESSURE/TEMPERATURE RATINGS

In accordance with ASME B16.34

MATERIALS

DESCRIPTION	MATERIAL	ASTM Spec.
Body	Carbon Steel/Integral Stellite Seat (6" & smaller)	A-216, Grade WCB
Bonnet	Carbon Steel/Stellite Integral Back Seat	A-105
Yokearm	Carbon Steel	A-216, Grade WCB
Stem	Stainless Steel	† A-182, Grade F6a
Disc	Stainless Steel/ Stellite Facing	† A-276, Type 410
Disc Nut	Stainless Steel	† A-582, Type 416
Protective Ring	Stainless Steel	† A-473, Type 416
Packing Washer	Steel	A-108, Grade 1015/1025
Yokearm Face Ring	Stainless Steel	† A-473, Type 416
Bonnet Take-Up Flange	Chrome Nickel Moly Steel	AISI 4140
Gland	Brass	B-16
Gland Flange	Carbon Steel	A-216, Grade WCB
Segmental Thrust Ring	Stainless Steel	† A-473, Type 416
Stem Bushing	Brass	B-16
Handwheel	Carbon Steel	A-216, Grade WCB
Thrust Washer	Nitralloy Rod	Commercial
Stem Bushing Nut	Steel	A-108, Grade 1015/1025
Gasket	Soft Iron/Steel	
Packing	Grafoil	Commercial
Crossarm	Carbon Steel	A-216, Grade WCB
Take-Up Cap Screw	Steel	A-193, Grade B7
Lubricant Fitting	-	Commercial
Set Screw	Steel	Commercial
Eyebolts & Nuts	Steel	A-307, Grade B
Studs	Steel	A-193, Grade B7
Nuts	Steel	A-194, Grade 2H
Groov-Pins	Steel	Commercial
Split Thrust Ring	Stainless Steel	† A-473, Type 416
Handwheel Retainer Plate	Steel	A-108, Grade 1015/1025
Seat Ring	Steel/Stellite Facing (Above 6" Size)	A-519, Grade 1015/1026

† Or Equal

SPECIFICATIONS

- 600 class valves have Diameter of bore equivalent to Schedule 80 pipe, and will be furnished unless otherwise specified. Contour of weld ends to be the same as Figs. 2A or 3A, ASME B16.25. Welding Bore can be furnished to meet customer's specifications.
- Nominal pipe size, schedule of pipe, or bore or wall thickness, must be specified on 900 class valves and up, so that valve can be machined to match customer's pipe.
- When backing or chill rings are used, specific details must be given.

CAST STEEL PRESSURE SEAL "Y" GLOBE VALVES

WELDING ENDS

CLASS 600 through 2500

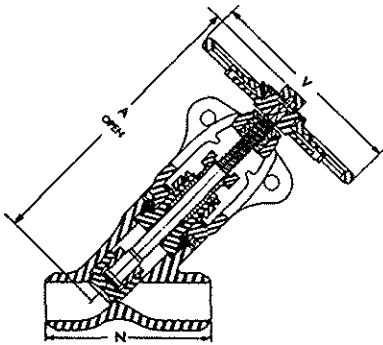

"Y" Globe Valve
with Hammerblow Handwheel

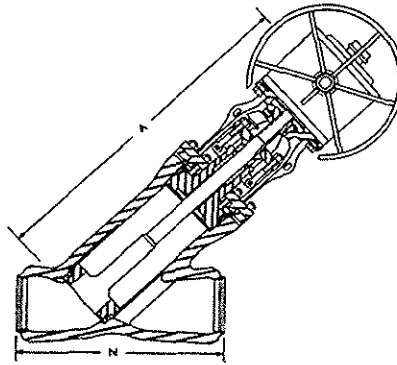

"Y" Globe Valve
Gear Operated

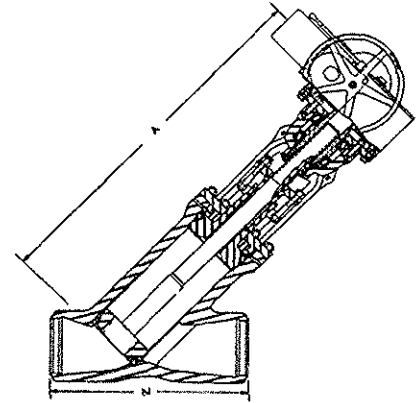

"Y" Globe Valve
Motor Operated

DIMENSIONS (Inches)

Size		2 1/2	3	4	5	6	8	10	12	14	16	18	20
600 Class Globe Fig. 16031Y WE	N	-	10	12	15	-	-	34	39	42	47	53	58
	A	-	24 1/8	27 3/4	29	-	-	59	65	74 1/4	87	101	113
	V	-	12*	16*	20*	-	-	**	**	**	**	**	**
900 Class Globe Fig. 19031Y WE	N	-	12	14	17	-	-	34	39	42	47	53	58
	A	-	24 3/4	30 1/2	29	-	-	59	65	74 1/4	87	101	113
	V	-	16*	22*	20*	-	-	**	**	**	**	**	**
1500 Class Globe Fig. 11331Y WE	N	10	12	16	19	27 3/4	32 3/4	39	44 1/2	-	-	-	-
	A	22 1/8	26 1/2	31	38	47 3/4	55	62 1/2	76	-	-	-	-
	V	12*	16*	22*	20*	30*	**	**	**	-	-	-	-
2500 Class Globe Fig. 125031Y WE	N	13	14	18	-	27 3/4	32 3/4	39	44 1/2	49 1/2	54 1/2	60 1/2	-
	A	22 7/8	26 1/2	30 1/8	-	47	56 1/2	57 1/2	76 1/8	84 5/8	95 7/16	100 5/8	-
	V	14*	16*	20*	-	30*	**	**	**	**	**	**	-

* Hammerblow Handwheel

** Handwheel actuated Valve Not Available - Consult Powell Engineering for proper selection of Manual Gear or Powered Actuator

• Anti-Friction Bearing Yoke

CAST STEEL PRESSURE SEAL UPRIGHT GLOBE and ANGLE VALVES

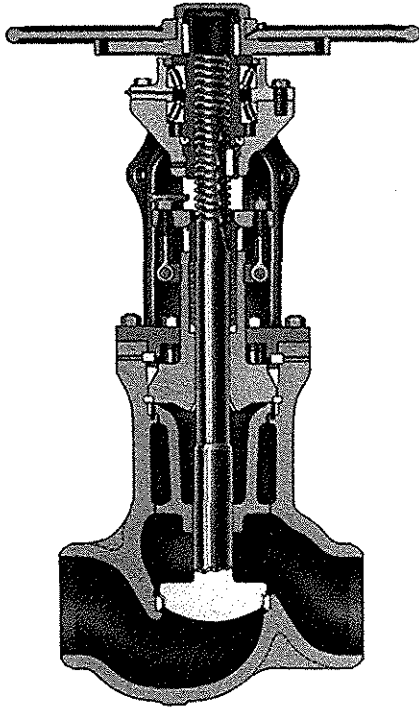

Pressure Seal Upright Globe Valve
With Hammerblow Handwheel

FEATURES

- Disc are accurately fitted and guided to minimize vibration. Seating surfaces are stellite. One piece stem and disc design are furnished on larger size valves
- Seat Ring is stellite faced, accurately fitted and seal welded in place
- Stellite faced back seat and stem guide insure tight sealing and accurate guiding of stem
- Yoke design - Studs fasten the yokearm directly to the valve body. The bolting and internal design features eliminate heavy clamp rings and provide rigidity, accurate alignment of the valve internal parts and operating mechanism
- Body has flow area that is designed for minimum turbulence and pressure drop
- Lifting lugs, on larger size valves, aid in installation and maintenance operation

CLASS 600-2500

PRESSURE SEAL BONNET WELDING ENDS

PRESSURE/TEMPERATURE RATINGS

In accordance with ASME B16.34

MATERIALS

DESCRIPTION	MATERIAL	ASTM Spec.
Body	Carbon Steel	A-216, Grade WCB
Bonnet	Carbon Steel/Stellite Integral Back Seat	A-105
Yokearm	Carbon Steel	A-216, Grade WCB
Stem	Stainless Steel	† A-182, Grade F6a
Disc	Steel/Stellite Facing	A-516, Grade 70
Protective Ring	Stainless Steel	† A-473, Type 416
Packing Washer	Steel	A-108, Grade 1015/1025
Retaining Ring	Stainless Steel	† A-473, Type 416
Gland	Brass	B-16
Gland Flange	Carbon Steel	A-216, Grade WCB
Segmental Thrust Ring	Stainless Steel	† A-473, Type 416
Gasket	Soft Iron/Steel	
Packing	Grafoil	Commercial
Lubricant Fitting	-	Commercial
Set Screw	Steel	Commercial
Eyebolts and Nuts	Steel	A-307, Grade B
Studs	Steel	A-193, Grade B7
Nuts	Steel	A-194, Grade 2H
Groov-Pins	Steel	Commercial
Seat Ring	Steel/Stellite Facing	A-519, Grade 1015/1026
Key Bushing	Steel	A-108, Grade 1015/1025
Key	Steel	A-108, Grade 1015/1025
Bearings	-	Commercial
Oil Seals	-	Commercial
Bearing Cap	Carbon Steel	A-216, Grade WCB
Disc Guide	Carbon Steel	A-216, Grade WCB
Hammerblow Handwheel	Carbon Steel	A-216, Grade WCB
Stem Bushing	Bronze	B-62
Crossarm	Carbon Steel	A-216, Grade WCB
Stem Bushing Nut	Steel	A-108, Grade 1015/1025
Handwheel Retainer Plate	Steel	A-108, Grade 1015/1025
Eyebolt Clamp	Carbon Steel	A-216, Grade WCB

† Or Equal

SPECIFICATIONS

- 600 class valves have Diameter of bore equivalent to Schedule 80 pipe, and will be furnished unless otherwise specified. Contour of weld ends to be the same as Figs. 2A or 3A, ASME B16.25. Welding Bore can be furnished to meet customer's specifications.
- Nominal pipe size, schedule of pipe, or bore or wall thickness, must be specified on 900 class valves and up, so that valve can be machined to match customer's pipe.
- When backing or chill rings are used, specific details must be given.

CAST STEEL PRESSURE SEAL GLOBE and ANGLE VALVES

WELDING ENDS

CLASS 600 through 2500

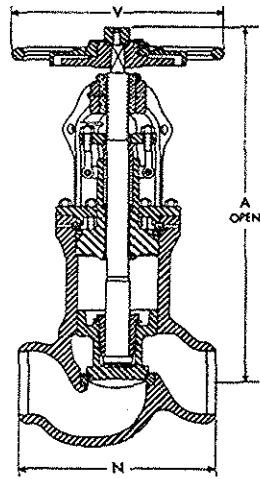

Globe Valve
with Hammerblow Handwheel

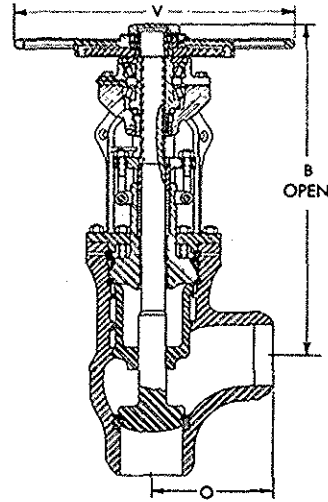

Angle Valve
with Hammerblow Handwheel
and Anti-friction Bearing Yoke

DIMENSIONS (Inches)

Size	2 1/2	3	4	5	6	8	10	12
600 Class								
Globe	N -	10	12	-	18	23	28†	-
Fig. 16031 WE	O -	6	7	8 1/2	10	-	-	-
Angle	A -	24 3/4	27	-	35	42 3/4	50	-
Fig. 16033 WE	B -	19 3/4	24	33	30 3/4	-	-	-
	V -	12*	16*	16*	20*	26*	30*	-
900 Class								
Globe	N -	-	-	-	20	26	31†	36†
Fig. 19031 WE	O -	6	7	8 1/2	10	13	15 1/2	18
Angle	A -	-	-	-	41 1/4	52 1/2	50	59 1/4
Fig. 19033 WE	B -	21 1/8	25 3/8	28	37 3/4	46	48 1/2	59 1/4
	V -	16	20*	20*	26*	30*	**	**
1500 Class								
Globe	N -	-	-	-	22†	28†	34†	-
Fig. 11331 WE	O 5	6	8	-	11	14	17	-
Angle	A -	-	-	-	44	50	62 1/2	-
Fig. 11333 WE	B 18 1/2	21 1/4	25 5/8	-	37 1/2	50	59 1/4	-
	V 12*	16*	20*	-	26*	**	**	-
2500 Class								
Globe	N -	-	-	-	-	-	-	-
Fig. 125031 WE	O 6 1/2	7 1/4	9	-	-	-	-	-
Angle	A -	-	-	-	-	-	-	-
Fig. 125033 WE	B 20 3/4	24 1/2	29 1/4	-	-	-	-	-
	V 14*	16*	20*	-	-	-	-	-

* Hammerblow Handwheel

** Handwheel actuated Valve Not Available - Consult Powell Engineering for proper selection of Manual Gear or Powered Actuator

† "Y" Design is Standard, Upright Design is available if specified

• Anti-Friction Bearing Yoke

CAST STEEL PRESSURE SEAL NON-RETURN "Y" GLOBE and ANGLE VALVES

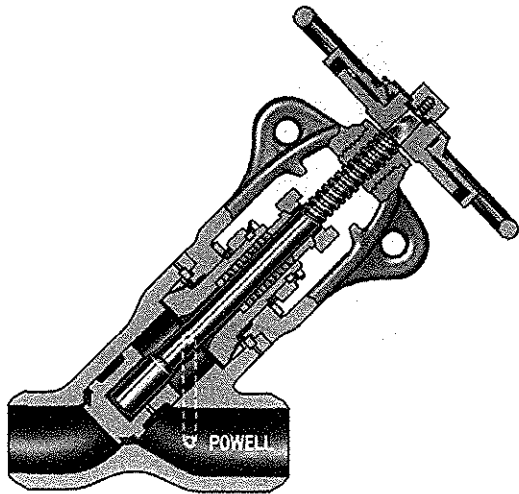

Pressure Seal Non-Return
"Y" Globe Valve

FEATURES

- Non-Return valves should always be mounted in a horizontal position with the stem pointing vertically upwards so the disc is free to close by gravity yet cushioned in the dash-pot
- Full floating, accurately guided discs. Seating surfaces are stellite
- Stellite faced back seat area and stem guide insure tight sealing and accurate guiding of stem
- Yoke design - Studs fasten the yoke directly to the valve body. The bolting and internal design features eliminate heavy clamp rings and provide rigidity, accurate alignment of the valve internal parts and operating mechanism
- Body has flow area that is designed for minimum turbulence and pressure drop
- Equalizer helps reduce pressure drop and prevents wear producing disc vibration. An external pressure-balancing line connects the high pressure zone above the disc with the lower pressure area in the valve outlet. This reduces the pressure above the disc causing the higher pressure below the disc to raise it to full lift; also higher and quicker at low rates of low, thereby giving improved pressure drop characteristics

CLASS 600-2500

PRESSURE SEAL BONNET WELDING ENDS

PRESSURE/TEMPERATURE RATINGS

In accordance with ASME B16.34

MATERIALS

DESCRIPTION	MATERIAL	ASTM Spec.
Body	Carbon Steel/ Integral Stellite Seat (6" & smaller)	A-216, Grade WCB
Bonnet	Carbon Steel/Stellite Integral Back Seat	A-105
Yokearm	Carbon Steel	A-216, Grade WCB
Stem	Stainless Steel	† A-182, Grade F6a
Disc	Stainless Steel/ Stellite Facing	† A-276, Type 410
Protective Ring	Stainless Steel	† A-473, Type 416
Packing Washer	Steel	A-108, Grade 1015/1025
Yokearm Face Ring	Stainless Steel	† A-473, Type 416
Bonnet Take-Up Flange	Chrome Nickel Moly Steel	AISI 4140
Split Thrust Ring	Stainless Steel	† A-473, Type 416
Gland	Brass	B-16
Gland Flange	Carbon Steel	A-216, Grade WCB
Segmental Thrust Ring	Stainless Steel	† A-473, Type 416
Stem Bushing	Bronze	B-62
Handwheel	Carbon Steel	A-216, Grade WCB
Stem Bushing Nut	Steel	A-108, Grade 1015/1025
Gasket	Soft Iron/Steel	
Packing	Grafoil	Commercial
Crossarm	Carbon Steel	A-216, Grade WCB
Take-Up Cap Screw	Steel	A-193, Grade B7
Lubricant Fitting	-	Commercial
Set Screw	Steel	Commercial
Eyebolts and Nuts	Steel	A-307, Grade B
Studs	Steel	A-193, Grade B7
Nuts	Steel	A-194, Grade 2H
Groov-Pins	Steel	Commercial
Equalizer	Steel	A-106, Grade B
Handwheel Retainer Plate	Steel	A-108, Grade 1015/1025
Seat Ring	Steel/Stellite Facing (Above 6" Size)	A-519, Grade 1015/1026

† Or Equal

SPECIFICATIONS

- 600 class valves have Diameter of bore equivalent to Schedule 80 pipe, and will be furnished unless otherwise specified. Contour of weld ends to be the same as Figs. 2A or 3A, ASME B16.25. Welding Bore can be furnished to meet customer's specifications.
- Nominal pipe size, schedule of pipe, or bore or wall thickness, must be specified on 900 class valves and up, so that valve can be machined to match customer's pipe.
- When backing or chill rings are used, specific details must be given.

CAST STEEL PRESSURE SEAL NON-RETURN "Y" GLOBE VALVES

WELDING ENDS
CLASS 600 through 2500

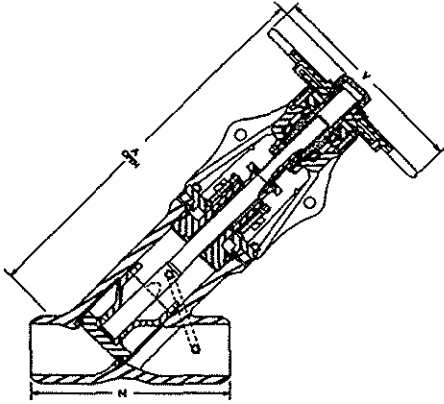

Non-Return "Y" Globe Valve
with Hammerblow Handwheel

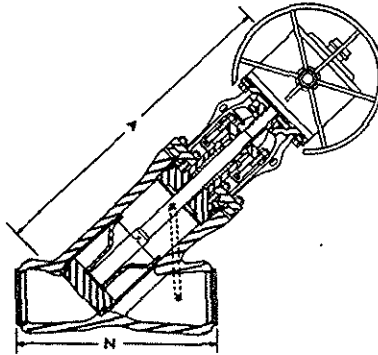

Non-Return "Y" Globe Valve
Gear Operated

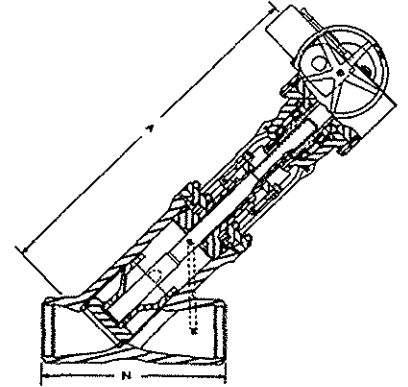

Non-Return "Y" Globe Valve
Motor Operated

DIMENSIONS (Inches)

Size		2 1/2	3	4	6	8	10	12	14	16	18	20
600 Class	N	-	10	12	-	-	34	39	42	47	53	58
Non-Return "Y" Globe Valve Fig. 16084Y WE	A	-	22 5/8	27 3/4	-	-	59	65	74 1/4	87	101 1/4	113
	V	-	12	16	-	-	**	**	**	**	**	**
900 Class	N	-	12	14	-	-	34	39	42	47	53	58
Non-Return "Y" Globe Valve Fig. 19084Y WE	A	-	24 3/4	30 1/2	-	-	59	61 3/4	74 1/4	87	101 1/4	113
	V	-	18*	22*	-	-	**	**	**	**	**	**
1500 Class	N	10	12	16	27 3/4	32 3/4	39	44 1/2	-	-	-	-
Non-Return "Y" Globe Valve Fig. 11384Y WE	A	21 5/8	24 3/4	30 1/2	47	55	62 1/2	76	-	-	-	-
	V	12*	18*	22*	30*	**	**	**	-	-	-	-
2500 Class	N	13	14 1/2	18	27 3/4	32 3/4	39	44 1/2	49 1/2	54 1/2	60 1/2	-
Non-Return "Y" Globe Valve Fig. 125084Y WE	A	22 7/8	26 1/2	33 3/8	47	56 1/2	57 1/2	76 1/8	84 5/8	95 7/16	100 5/8	-
	V	14*	16*	20*	30*	**	**	**	**	**	**	-

* Hammerblow Handwheel

** Handwheel Actuated Valve Not Available - Consult Powell Engineering for proper selection of Manual Gear or Powered Actuator

• Anti-Friction Bearing Yoke

CAST STEEL PRESSURE SEAL NON-RETURN UPRIGHT GLOBE and ANGLE VALVES

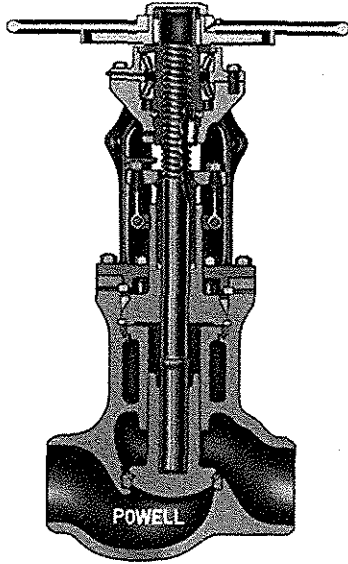

Pressure Seal Non-Return
Upright Globe Valve

FEATURES

- Non-Return valves should always be mounted in a horizontal position with the stem pointing vertically upwards so the disc is free to close by gravity yet cushioned in the dash-pot
- Discs are full floating and accurately guided. Seating surfaces are stellite
- Seat Rings are stellite faced, accurately fitted and seal welded in place
- Stellite faced back seat area and stem guide insure tight sealing and accurate guiding of stem
- Yoke design - Studs fasten the yoke directly to the valve body. The bolting and internal design features eliminate heavy clamp rings and provide rigidity, accurate alignment of the valve internal parts and operating mechanism
- Body has flow area that is designed for minimum turbulence and pressure drop
- Lifting Lugs, on larger size valves, aid in installation and maintenance operation

CLASS 600-2500

PRESSURE SEAL BONNET WELDING ENDS

PRESSURE/TEMPERATURE RATINGS

In accordance with ASME B16.34

MATERIALS

DESCRIPTION	MATERIAL	ASTM Spec.
Body	Carbon Steel	A-216, Grade WCB
Bonnet	Carbon Steel/Stellite Integral Back Seat	A-105
Yokearm	Carbon Steel	A-216, Grade WCB
Stem	Stainless Steel	† A-182, Grade F6a
Seat Ring	Steel/Stellite Facing	A-519, Grade 1015/1026
Key	Steel	A-108, Grade 1015/1025
Protective Ring	Stainless Steel	† A-473, Type 416
Retaining Ring	Stainless Steel	† A-473, Type 416
Packing Washer	Steel	A-108, Grade 1015/1025
Gland	Brass	B-16
Gland Flange	Carbon Steel	A-216, Grade WCB
Segmental Thrust Ring	Stainless Steel	† A-473, Type 416
Stem Bushing	Bronze	B-62
Handwheel	Carbon Steel	A-216, Grade WCB
Stem Busing Nut	Steel	A-108, Grade 1020
Gasket	Soft Iron/Steel	
Packing	Grafoil	Commercial
Crossarm	Carbon Steel	A-216, Grade WCB
Lubricant Fitting	-	Commercial
Set Screw	Steel	
Eyebolts and Nuts	Steel	A-307, Grade B
Eyebolt Clamp	Carbon Steel	A-216, Grade WCB
Studs	Steel	A-193, Grade B7
Nuts	Steel	A-194, Grade 2H
Disc Guide	Stainless Steel	A-217, Grade CA15
Disc	Carbon Steel/ Stellite Facing	A-216, Grade WCB
Key Bushing	Steel	A-108, Grade 1015/1025
Bearing Cap	Carbon Steel	A-216, Grade WCB
Groov-Pins	Steel	Commercial
Bearings	-	Commercial
Handwheel Retainer Plate	Steel	A-108, Grade 1015/1025
Oil Seals	-	Commercial

† Or Equal

SPECIFICATIONS

- 600 class valves have Diameter of bore equivalent to Schedule 80 pipe, and will be furnished unless otherwise specified. Contour of weld ends to be the same as Figs. 2A or 3A, ASME B16.25. Welding Bore can be furnished to meet customer's specifications.
- Nominal pipe size, schedule of pipe, or bore or wall thickness, must be specified on 900 class valves and up, so that valve can be machined to match customer's pipe.
- When backing or chill rings are used, specific details must be given.

CAST STEEL PRESSURE SEAL NON-RETURN VALVES

GLOBE and ANGLE WELDING ENDS

CLASS 600 through 2500

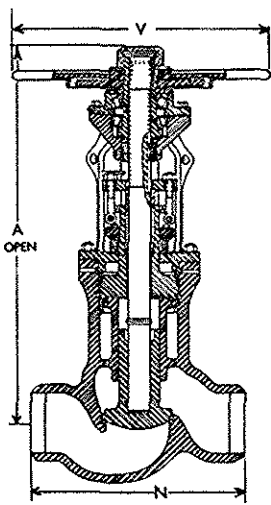

Non-Return Globe Valve
Hammerblow Handwheel

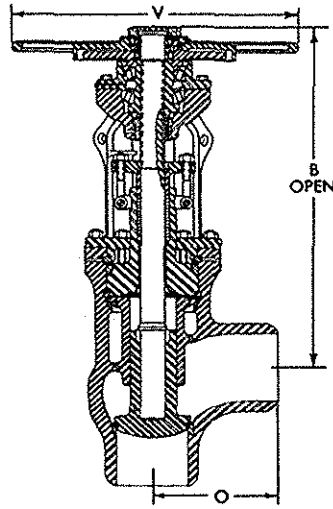

Non-Return Angle Valve
Hammerblow Handwheel

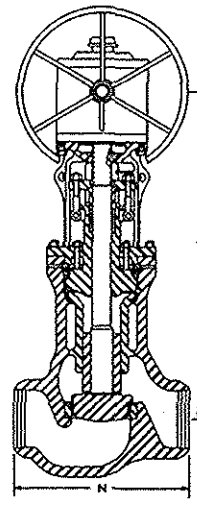

Non-Return Globe Valve
Gear Operated

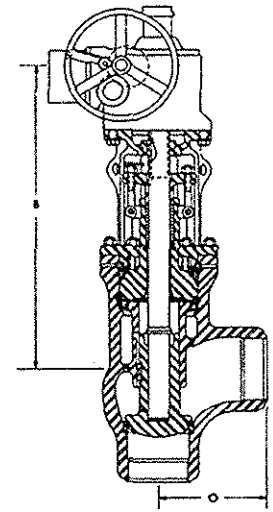

Non-Return Angle Valve
Motor Operated

DIMENSIONS (Inches)

Size		2 1/2	3	4	5	6	8	10	12
600 Class Globe Fig. 16084 WE Angle Fig. 16086 WE	N	-	10	12	-	18	23	28†	-
	O	-	6	7	8 1/2	10	-	-	-
	A	-	24 3/4	27	-	35	42 3/4	58	-
	B	-	19 3/4	24	33	30 3/4	-	-	-
	V	-	12*	16*	16*	20*	26*	30*	-
900 Class Globe Fig. 19084 WE Angle Fig. 19086 WE	N	-	-	-	-	20	26	31†	36†
	O	-	6	7	8 1/2	10	13	15 1/2	18
	A	-	-	-	-	41 1/4	52 1/2	50	59 1/4
	B	-	21 1/8	25 5/8	28	37 3/4	46	48 1/2	59 1/4
	V	-	16*	20*	20*	26*	30*	**	**
1500 Class Globe Fig. 11384 WE Angle Fig. 11386 WE	N	-	-	-	-	22†	28†	34†	-
	O	5	6	8	-	11	14	17	-
	A	-	-	-	-	44	50	62 1/2	-
	B	18 1/2	21 1/4	25 3/4	-	37 1/2	50	59 1/4	-
	V	12*	16*	20*	-	26*	**	**	-
2500 Class Globe Fig. 125084 WE Angle Fig. 125086 WE	N	-	-	-	-	-	-	-	-
	O	6 1/2	7 1/4	9	-	-	-	-	-
	A	-	-	-	-	-	-	-	-
	B	20 3/4	24 1/2	29 1/4	-	-	-	-	-
	V	14*	16*	20*	-	-	-	-	-

* Hammerblow Handwheel

** Handwheel Actuated Valve Not Available - Consult Powell Engineering for proper selection of Manual Gear or Powered Actuator

† "Y" Design is Standard, Upright Design is available if specified

• Anti-Friction bearing Yoke

CAST STEEL PRESSURE SEAL HORIZONTAL, ANGLE & "Y" LIFT CHECK VALVES

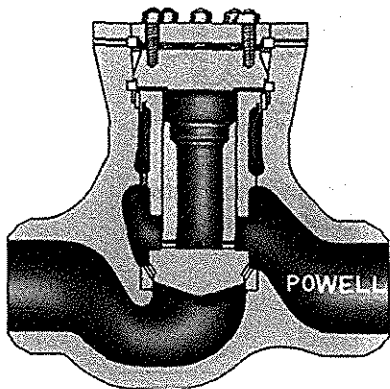

Pressure Seal Horizontal Lift
Check Valve

FEATURES

- Discs are accurately fitted and guided to minimize vibration. Seating surfaces are stellite
- Seat Rings are stellite faced, accurately fitted and seal welded in place
- Body has flow area that is designed for minimum turbulence and pressure drop

CLASS 600-2500

WELDING ENDS

PRESSURE/TEMPERATURE RATINGS

In accordance with ASME B16.34

MATERIALS

DESCRIPTION	MATERIAL	ASTM Spec.
Body	Carbon Steel	A-216, Grade WCB
Disc	Carbon Steel/ Stellite Facing	A-216, Grade WCB
Seat Ring	Steel/Stellite Facing	A-519, Grade 1015/1026
Protective Ring	Stainless Steel	† A-473, Type 416
Segmental Thrust Ring	Stainless Steel	† A-473, Type 416
Segmental Retaining Ring	Stainless Steel	† A-473, Type 416
Disc Guide	Stainless Steel	A-217, Grade CA15
Cap	Carbon Steel	† A-105
Retainer Plate	Steel	A-36
Gasket	Soft Iron/Steel	
Studs	Steel	A-193, Grade B7
Hex Nuts	Steel	A-194, Grade 2H
Equalizer Pipe‡	Steel	A-106, Grade B

† Or Equal

‡ "Y" Lift Check Only

SPECIFICATIONS

- 600 class valves have Diameter of bore equivalent to Schedule 80 pipe, and will be furnished unless otherwise specified. Contour of weld ends to be the same as Figs. 2A or 3A, ASME B16.25. Welding Bore can be furnished to meet customer's specifications.
- Nominal pipe size, schedule of pipe, or bore or wall thickness, must be specified on 900 class valves and up, so that valve can be machined to match customer's pipe.
- When backing or chill rings are used, specific details *must be given*.

CAST STEEL PRESSURE SEAL LIFT CHECK VALVES

HORIZONTAL and ANGLE WELDING ENDS

CLASS 600 through 2500

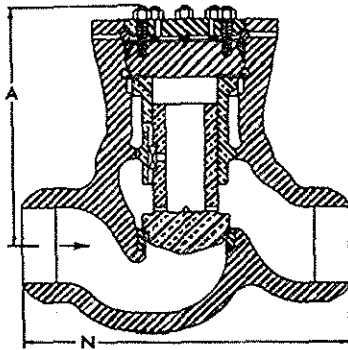

Horizontal Lift Check Valve

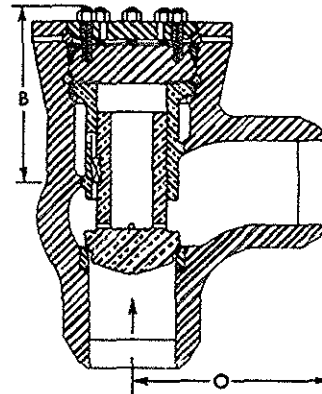

Angle Lift Check Valve

DIMENSIONS (Inches)

Size		2 1/2	3	4	5	6	8	10	12	14	
600 Class	Horizontal	N	-	10	12	-	18	23	28	-	-
	Fig. 16065 WE	O	-	6	7	8 1/2	10	-	-	-	-
	Angle	A	-	10 1/2	10 3/4	-	17 3/4	21	26	-	-
	Fig. 16067 WE	B	-	6 1/4	7 3/4	11 3/4	13	-	-	-	-
900 Class	Horizontal	N	-	-	-	20	26	31	-	-	
	Fig. 19065 WE	O	-	6	7	8 1/2	10	13	15 1/2	-	-
	Angle	A	-	-	-	18 1/2	22 1/4	25 1/2	-	-	
	Fig. 19067 WE	B	-	6	8 3/4	9 1/2	11 1/2	16	16	-	-
1500 Class	Horizontal	N	-	-	-	22	28	34	-	-	
	Fig. 11365 WE	O	5	6	8	-	11	14	17	19 1/2	21
	Angle	A	-	-	-	-	16 1/2	20 1/4	23 1/4	27 3/4	32 1/4
	Fig. 11367 WE	B	6 1/8	6 1/8	7 1/4	-	10	15 3/4	20	20 3/4	20 3/4
2500 Class	Horizontal	N	-	-	-	-	-	-	-	-	
	Fig. 125065 WE	O	6 1/2	7 1/4	9	-	12	15	18	-	-
	Angle	A	-	-	-	-	-	-	-	-	-
	Fig. 125067 WE	B	7	7 1/2	8	-	11 1/4	13 1/2	19 1/4	-	-

CAST STEEL PRESSURE SEAL LIFT CHECK VALVES "Y" HORIZONTAL

WELDING ENDS
CLASS 600 through 2500

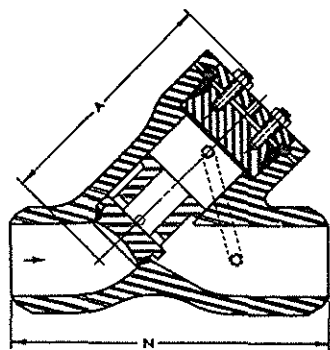

"Y" Horizontal Lift Check Valve
Sizes, 4" and Smaller

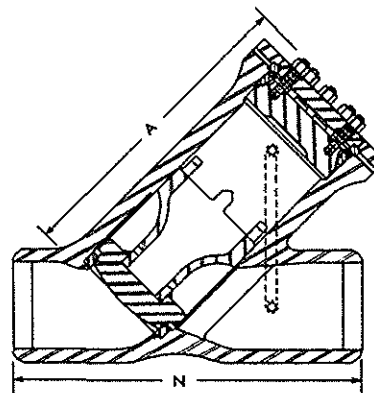

"Y" Horizontal Lift Check Valve
Sizes, 6" and Larger

DIMENSIONS (Inches)

Size		2 1/2	3	4	6	8	10	12	14	16	18	20
600 Class Horizontal "Y" Fig. 16065Y WE	N	-	10	12	-	-	34	39	42	47	53	58
	A	-	10 3/4	12 3/4	-	-	30	32	34	38	43	49 1/2
900 Class Horizontal "Y" Fig. 19065Y WE	N	-	12	14	-	-	34	39	42	47	53	58
	A	-	9 5/8	12 1/8	-	-	30	32	34	38	43	49 1/2
1500 Class Horizontal "Y" Fig. 11365Y WE	N	10	12	16	27 3/4	32 3/4	39	44 1/2	-	-	-	-
	A	9 3/8	9 5/8	12 1/8	18 1/2	26 9/16	30	30	-	-	-	-
2500 Class Horizontal "Y" Fig. 125065Y WE	N	13	14 1/2	18	27 3/4	32 3/4	39	44 1/2	49 1/2	54 1/2	60 1/2	-
	A	12 1/2	15	17 1/4	27 1/2	30	33	36	38	42	45	-

CAST STEEL PRESSURE SEAL SWING CHECK VALVES

WELDING ENDS

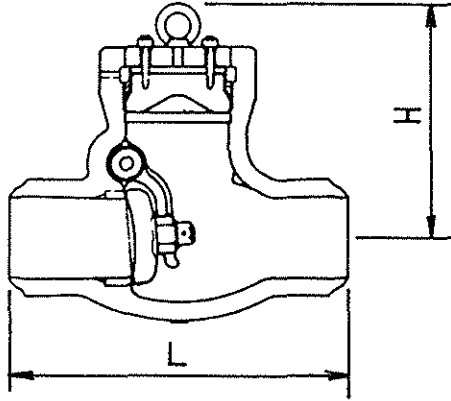

Fig. 16061WE Sizes, 2" through 24"
 Fig. 19061WE Sizes, 2" through 24"
 Fig. 11361WE Sizes, 2" through 24"
 Fig. 125061WE Sizes, 2" through 12"

CLASS 600-2500

PRESSURE/TEMPERATURE RATINGS

In accordance with ASME B16.34

MATERIALS (Carbon Steel)

DESCRIPTION	ASTM Spec.
BODY	A216WCB
COVER	A216WCB
ARM	A216WCB
BODY SEAT RING	C/S1020+STL No.6
DISC	A216WCB+STL No.6
RETAINER	A479-410
PIN	A479-410
DISC NUT	A194GrB
PLUG	A307B
GASKET	SOFT STEEL
COVER CLAMP BOLT	A193 B7
NUT	A194-2H
ADAPTER RING	A479-410
COVER CLAMP	C/S1045
SEALING BOLT	A479-410
GASKET RING	SOFT STEEL
EYE BOLT	A105
WASHER	A479-410
SPLIT PIN	A580-304
SEALING NUT	A194-2H
PLUG BOLT	A307B
COVER NUT	A194-2H
COVER	A216WCB
BONNET	A216WCB

DIMENSIONS (Inches)

Size	2	3	4	6	8	10	12	14	16	18	20	24	
Class 600 Fig. 16061WE	L	7	10	12	18	23	28	32	35	39	43	47	55
	H	7 1/2	9 3/4	12 1/8	14 3/8	16 1/8	18 3/8	20 1/8	22 1/8	24 3/8	26 1/2	28 3/4	30 7/8
Class 900 Fig. 19061WE	L	8 1/2	12	14	20	26	31	36	39	43	48	52	61
	H	9 1/2	9 1/2	13 3/8	15 3/4	18 1/8	21	24	27	29 3/4	32 5/8	35 3/8	38 1/4
Class 1500 Fig. 11361WE	L	8 1/2	12	16	22	28	34	39	42	47	60 1/2	65 1/2	76 1/2
	H	9 5/8	11 3/4	13 3/4	16	19 1/4	22 5/8	26 7/8	29 5/8	31 5/8	34 1/2	36 7/8	40 5/8
Class 2500 Fig. 125061WE	L	11	14 1/2	18	24	30	36	41	-	-	-	-	-
	H	10 1/4	13 3/4	16	17 3/4	20 1/2	23 5/8	27	-	-	-	-	-

CAST STEEL PRESSURE SEAL TILTING DISC CHECK VALVES

WELDING ENDS

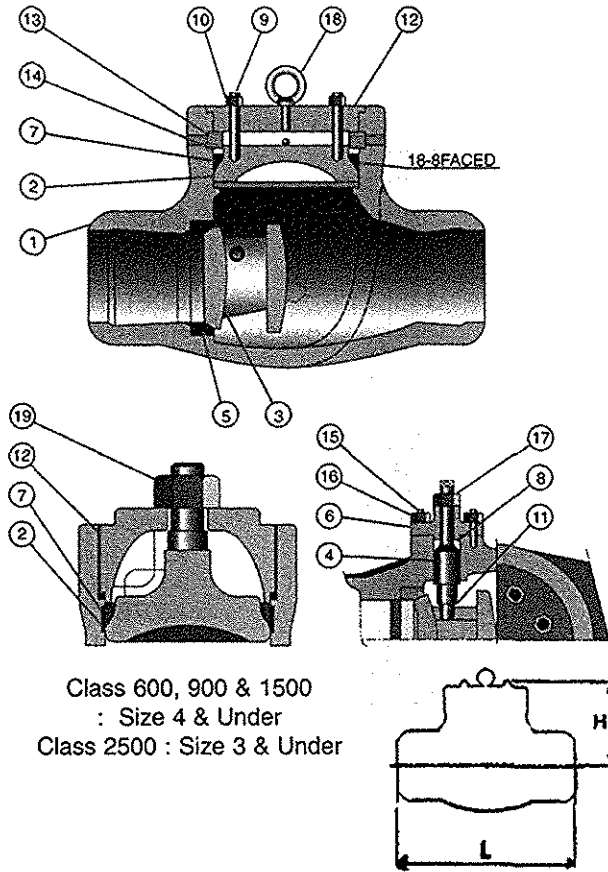

Class 600, 900 & 1500
: Size 4 & Under
Class 2500 : Size 3 & Under

Flanged End Valves Available on Special Order

CLASS 600-2500

PRESSURE/TEMPERATURE RATINGS
In accordance with ASME B16.34

MATERIALS (Carbon Steel)

DESCRIPTION	ASTM Spec.
1 BODY	A216-WCB
2 BONNET	A216-WCB
3 DISC	A216-WCB+STL
4 HINGE PIN	A479-410
5 BODY SEAT RING	A576-1020+STL
6 COVER	A105
7 GASKET	SOFT STEEL
8 COVER GASKET	SOFT STEEL
9 BONNET BOLT	A193-B7
10 BONNET NUT	A194-2H
11 BUSHING	A479-304
12 BONNET CLAMP	A576-1045
13 RETAINER	A576-1020+ZnPlat
14 ADAPTER RING	A576-1020+ZnPlat
15 COVER BOLT	A193-B7
16 COVER NUT	A194-2H
17 HINGE PIN NUT	A194-2H
18 EYE BOLT	A307-B
19 BONNET NUT	A194-2H

SPECIFICATIONS

- Flanged and Butt Welding End valves conform to ANSI B16.5, B16.10, B16.25, B16.34 and API 600

DIMENSIONS (Inches)

CLASS 600 Fig. 16095WE

Size	2	2 1/2	3	4	6	8	10	12	14	16	18	20	24
L	7	8 1/2	10	12	18	23	28	32	35	39	43	47	55
H	7 1/2	7 7/8	8 1/4	9 3/8	10 5/8	12	13 5/8	16 1/8	17 3/4	20 1/8	21 3/4	23 1/4	25 3/8

CLASS 900 Fig. 19095WE

Size	2	2 1/2	3	4	6	8	10	12	14	16	18	20	24
L	8 1/2	10	12	14	20	26	31	36	39	43	48	52	61
H	5 5/8	8	9	9 7/8	11 5/8	13 1/8	15 1/8	18 1/8	19 1/2	21 7/8	22 7/8	24 3/8	27 3/8

CLASS 1500 Fig. 11095WE

Size	2	2 1/2	3	4	6	8	10	12	14	16	18	20	24
L	8 1/2	10	12	16	22	28	34	39	42	47	60 1/2	65 1/2	76 1/2
H	7 5/8	8 1/8	9	9 7/8	10 1/4	11 3/4	15 7/8	19	20 1/8	22 1/4	23 1/4	24 3/8	28 7/8

CLASS 2500 Fig. 125095WE

Size	2	2 1/2	3	4	6	8	10	12	14	16	18
L	11	13	14 1/2	18	24	30	36	41	44	49	55
H	7 1/4	7 7/8	9 3/8	9 7/8	11 3/4	14 5/8	16 5/8	21 1/4	22 7/8	20 1/2	24 3/4

CAST STEEL VALVES with BY-PASS

GATE • GLOBE • ANGLE • NON-RETURN

CLASS 150 • 300 • 600 • 900 • 1500 • 2000 • 2500

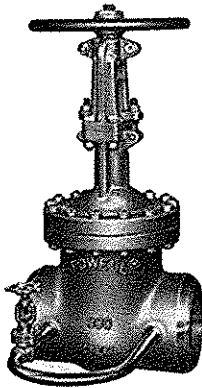

Welding End Gate Valve
With By-Pass

Powell Cast Steel Valves can be furnished with By-Passes in sizes shown on the following page. By-Passes are suitable for equalizing the pressure around main control valves used on steam and other fluids. The By-Pass unit has all connections socket welded to make a strong tight joint.

When valves are ordered with By-Pass, the By-Pass unit shall be attached at the side of the main valve with the stems of both valves parallel, pointing vertically upward as illustrated. By-Pass valves may also be attached to the bottom of the main valve, with stem of the By-Pass valve at right angle to the main valve stem. If By-Pass valve is to be attached in any special location, a sketch must accompany the order.

GATE VALVE FIGURE NUMBERS

Flanged Ends Bolted Bonnet

Fig. 1513-Class 150
Fig. 3013-Class 300
Fig. 6013-Class 600
Fig. 9013-Class 900
Fig. 1313-Class 1500

Welding Ends Bolted Bonnet

Fig. 1513WE-Class 150
Fig. 3013WE-Class 300
Fig. 6013WE-Class 600
Fig. 9013WE-Class 900
Fig. 1313WE-Class 1500

Welding Ends Pressure Seal Bonnet

Fig. 16013WE-Class 600
Fig. 19013WE-Class 900
Fig. 11313WE-Class 1500
Fig. 120013WE-Class 2000
Fig. 125013WE-Class 2500

GLOBE VALVE FIGURE NUMBERS

Flanged Ends Bolted Bonnet

Fig. 1541-Class 150
Fig. 3041-Class 300
Fig. 6041-Class 600
Fig. 9041-Class 900
Fig. 1341-Class 1500

Welding Ends Bolted Bonnet

Fig. 1541WE-Class 150
Fig. 3041WE-Class 300
Fig. 6041WE-Class 600
Fig. 9041WE-Class 900
Fig. 1341WE-Class 1500

Welding Ends Pressure Seal Bonnet

Fig. 16041WE-Class 600
Fig. 19041WE-Class 900
Fig. 11341WE-Class 1500
Fig. 125041WE-Class 2500

ANGLE VALVE FIGURE NUMBERS

Flanged Ends Bolted Bonnet

Fig. 1543-Class 150
Fig. 3043-Class 300
Fig. 6043-Class 600
Fig. 9043-Class 900

Welding Ends Bolted Bonnet

Fig. 1543WE-Class 150
Fig. 3043WE-Class 300
Fig. 6043WE-Class 600
Fig. 9043WE-Class 900

Welding Ends Pressure Seal Bonnet

Fig. 16043WE-Class 600
Fig. 19043WE-Class 900
Fig. 11343WE-Class 1500
Fig. 125043WE-Class 2500

CAST STEEL VALVES with BY-PASS

CLASS 150 • 300 • 600 • 900 • 1500 • 2000 • 2500

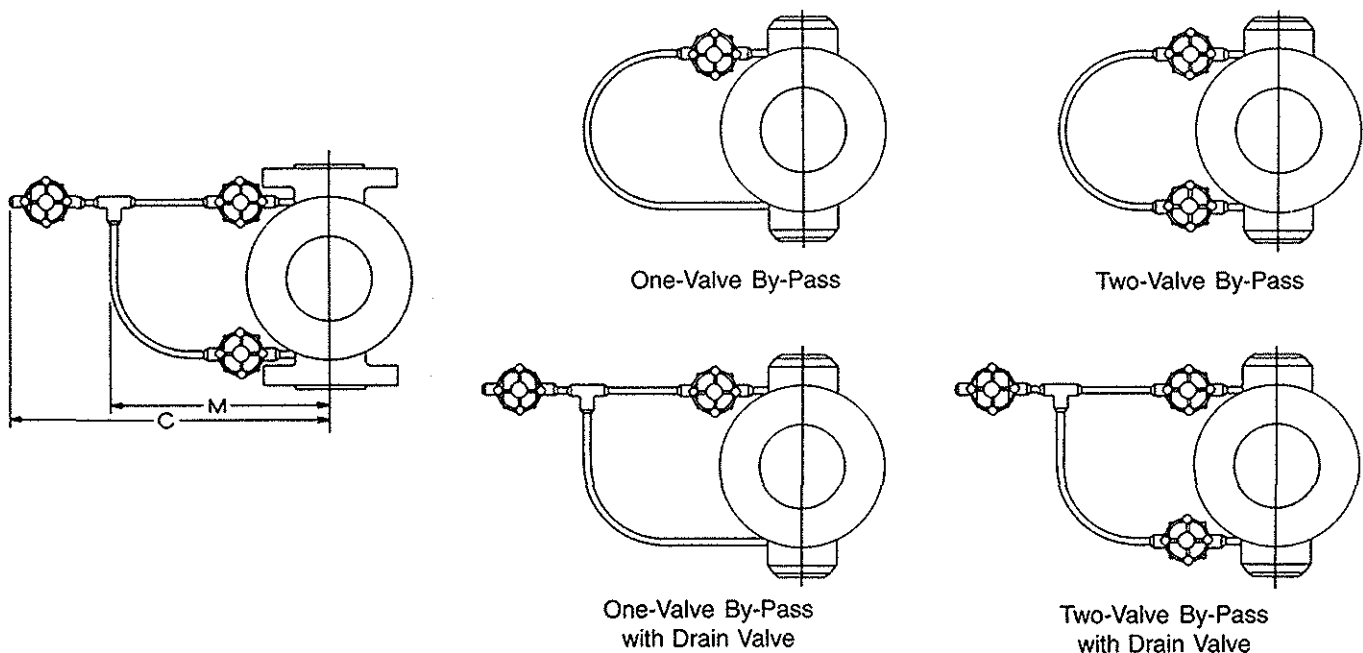

BY-PASS SIZES AND CLEARANCE DIMENSIONS-BOLTED BONNET (Inches)

Size of Valve			4	6	8	10	12	14	16	18	20	24
Size of By-Pass			1/2	3/4	3/4	1	1	1	1	1	1	1
Built-up By-Passes for Use with Main Valves Approximate Clearance, Inches	150 Class	M - F.E.	-	-	17 1/2	19 13/16	21 1/8	23 1/8	23 3/4	25 1/8	25 1/2	28 3/4
		M - W.E.	-	-	18 7/8	20 7/8	21 13/16	24 1/2	25 9/16	25 13/16	26 7/8	30
		C - F.E.	-	-	23 3/8	26 11/16	28	30	30 5/8	32	32 3/8	35 5/8
		C - W.E.	-	-	24 3/4	27 3/4	28 11/16	31 3/8	32 7/16	32 11/16	33 3/4	36 7/8
	300 Class	M	-	-	18 13/16	20 13/16	22 1/8	24 3/4	25 3/4	27 1/4	28 1/2	31 1/8
		C	-	-	24 11/16	27 11/16	29	31 5/8	32 5/8	34 1/8	35 3/8	38
	600 Class	M	16 7/8	19 3/8	20 1/2	24 1/4	25 1/4	26	26 7/8	30 3/4	30 3/4	-
		C	22	25 3/8	26 1/2	31	32	32 3/4	33 5/8	37 1/2	37 1/2	-
	900 Class	M	16 7/8	19 1/2	20 5/8	24 1/4	25 3/8	26 1/8	27 1/4	30 1/8	-	-
		C	22 1/8	25 1/2	26 5/8	31	32 1/8	32 7/8	34	36 7/8	-	-
	1500 Class	M	17	19 5/8	20 3/4	24 1/4	25 3/8	-	-	-	-	-
		C	22 3/8	25 3/4	26 7/8	31 1/8	32 3/8	-	-	-	-	-

BY-PASS SIZES AND CLEARANCE DIMENSIONS-PRESSURE SEAL BONNET (Inches)

Size of Valve			4	6	8	10	12	14	16	18	20	24
Size of By-Pass			1/2	3/4	3/4	1	1	1	1	1	1	1
Built-up By-Passes for Use with Main Valves Approximate Clearance, Inches	600 Class	M	17	24 5/8	25 1/2	27 5/8	29 1/8	30 1/8	29 1/2	29 3/4	31	33 1/4
		C	23 1/2	32 5/8	33 1/2	35 7/8	37 1/4	38 1/4	37 5/8	37 7/8	39 1/8	41 3/8
	900 Class	M	17	24 1/2	25 1/8	27 1/2	28 1/2	29 5/8	29	30 1/2	31 1/2	33 3/4
		C	23 1/2	32 1/2	33 1/4	35 5/8	36 5/8	37 3/4	37 1/8	38 5/8	39 5/8	41 7/8
	1500 Class	M	17	24 1/2	25 5/8	28 1/4	28	28 3/4	29 7/8	-	-	-
		C	23 1/2	32 1/2	33 3/4	36 3/8	36 1/8	36 7/8	38	-	-	-
2500 Class	M C	} Dimensions on Request										

CAST STEEL MOTOR-ACTUATED VALVES

FIGURE NUMBERS

BOLTED and PRESSURE SEAL BONNETS

All Powell Cast Steel Gate, Globe, Angle and Non-Return Valves may be obtained with motor operators. Existing hand actuated valves can be fitted for motor operation.

Please specify the following figure numbers for respective motor actuated valves:

	Flanged Ends	Welding Ends
150 CLASS		
Gate Valve-Bolted Bonnet	1523	1523 WE
Globe Valve-Bolted Bonnet	1551	1551WE
Angle Valve-Bolted Bonnet	1553	1553 WE
300 CLASS		
Gate Valve-Bolted Bonnet	3023	3023WE
Globe Valve-Bolted Bonnet	3051	3051 WE
Angle Valve-Bolted Bonnet	3053	3053 WE
600 CLASS		
Gate Valve-Bolted Bonnet	6023	6023 WE
Globe Valve-Bolted Bonnet	6051	6051 WE
Angle Valve-Bolted Bonnet	6053	6053 WE
Gate Valve-Pressure Seal Bonnet		16023 WE
Globe Valve-Pressure Seal Bonnet		16051 WE
Angle Valve-Pressure Seal Bonnet		16053 WE
900 CLASS		
Gate Valve-Bolted Bonnet	9023	9023 WE
Globe Valve-Bolted Bonnet	9051	9051 WE
Angle Valve-Bolted Bonnet	9053	9053 WE
Gate Valve-Pressure Seal Bonnet		19023 WE
Globe Valve-Pressure Seal Bonnet		19051 WE
Angle Valve-Pressure Seal Bonnet		19053 WE
1500 CLASS		
Gate Valve-Bolted Bonnet	1323	1323 WE
Globe Valve-Bolted Bonnet	1351	1351 WE
Gate Valve-Pressure Seal Bonnet		11323 WE
Globe Valve-Pressure Seal Bonnet		11351 WE
Angle Valve-Pressure Seal Bonnet		11353 WE
2500 CLASS		
Gate Valve-Bolted Bonnet	25023	25023 WE
Gate Valve-Pressure Seal Bonnet		125023 WE
Globe Valve-Pressure Seal Bonnet		125051 WE
Angle Valve-Pressure Seal Bonnet		125053 WE

For additional Motor Actuated Valve Information see page 136

CORROSION RESISTANT VALVES

GENERAL INDEX

	PAGE	
METAL and ALLOY DESIGNATIONS	81	
STANDARDS and SPECIFICATIONS	81	
 GATE VALVES		
Class 200 Screwed-in Bonnet	82	
Class 150-200 O.S. & Y.	83, 84	
Class 300 O.S. & Y.	85	
Class 600 O.S. & Y.	86	
 GLOBE VALVES		
Class 200 Union Bonnet	87	
Class 150-200 O.S. & Y.	88, 89	
Class 300 O.S. & Y.	90, 91	
Class 600 O.S. & Y.	92	
3000 PSI Needle Globe	93	
 CHECK VALVES - SWING CHECK		
200 WOG Screwed-in Cap	93	
Class 150-200 Bolted Cap	94, 95	
Class 300 Bolted Cap	96	
Class 600 Bolted Cap	97	
 CHECK VALVES - HORIZONTAL LIFT		
Class 150-200 Bolted Cap	98	
Class 300 Bolted Cap	99	
Class 600 Bolted Cap	100	
 FLUSH BOTTOM TANK VALVES		
Class 150	101, 102	
Class 300	103	
Class 600	104	
 MOTOR OPERATED VALVES		135
HYDRAULIC, PNEUMATIC OPERATED VALVES		136

Powell Corrosion Resistant Valves are available in standard to highly specialized designs, for example, NACE (National Association of Corrosion Engineers), etc. Standard Corrosion Resistant Valves contain PTFE with a service temperature limit of 450°F. Packing and Gaskets for higher temperature service are available on request.

METAL and ALLOY DESIGNATIONS FOR CORROSION RESISTANT VALVES

ALLOYS	TYPE	A.S.T.M. Designation
<i>Stainless:</i>		
CF-3	304L	A351, Grade CF-3
CF-8	304	A351, Grade CF-8
CF-3M	316L	A351, Grade CF-3M
CF-8M	316	A351, Grade CF-8M
CN-7M	Alloy 20	A351, Grade CN-7M
CD-4MCu	Duplex	A351, Grade CD-4MCu
<i>Nickel:</i>		
Nickel	Nickel	A494, CZ100
	Nickel	B160
Nickel Copper	Monel	A494, M35-1 and M35-2
	Monel	B164, UNS N04405
	Monel	B164, UNS N04400
Nickel-Molybdenum	Hastelloy B	A494, Grade N-12M
	Hastelloy B	B335, UNS N10665
Nickel-Molybdenum-Chromium	Hastelloy C	B574
	Hastelloy C	A494, Grade CW12-MW

Other Alloy Materials Available

FUGITIVE EMISSIONS OPTIONS

Powell standard design corrosion resistant valves are designed and manufactured to meet Level I-500 ppm maximum fugitive emissions. Level II-100 ppm maximum emissions - is optionally available.

STANDARDS and SPECIFICATIONS

In the interest of uniformity and safety for the consumer, a number of national organizations have developed and published Standards and Specifications. These standards and specifications prescribe the rules and regulations for the construction of boilers and pressure vessels, including valves and safety appliances, specifications for materials,

dimensional standards and requirements for piping system.

Powell Corrosion Resistant Valves and Engineering Specialities, wherever applicable, conform to the requirements set forth in the publications (latest editions) of the following associations.

API – American Petroleum Institute
Specifications

MSS – Manufacturers' Standardization
Society of the Valve and Fittings
Industry
Standard Practices

ASME – American Society of Mechanical
Engineers
Boiler Construction and Unfired
Pressure Vessel Code

ANSI – American National
Standards Institute

ASTM – American Society for Testing
Materials
Material Specifications

NACE – National Association of
Corrosion Engineers

CORROSION RESISTANT GATE VALVES

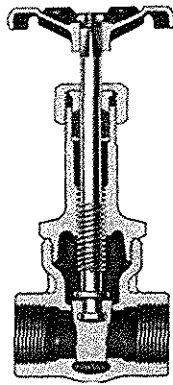

Fig. 1832

Threaded
Sizes, 1/4" through 2"

FEATURES

- Fully guided Solid Wedge
- Integral Seats
- Socket and Butt Welding End valves are available

CLASS 200 SCREWED-IN BONNET INSIDE SCREW RISING STEM THREADED ENDS

PRESSURE/TEMPERATURE RATINGS

In accordance with ASME B16.34

MATERIALS

DESCRIPTION	MATERIAL	ASTM Spec.
Handwheel Nut	Steel	Commercial
Identification Plate	Aluminum	Commercial
Handwheel	Malleable Iron	A-47, Grade 32510
Stem	Stainless Steel	A-276, Type 316
Packing Gland	Stainless Steel	A-276, Type 316
Packing Nut	Stainless Steel	A-276, Type 316
Packing	PTFE	Commercial
Packing Collar	Stainless Steel	A-276, Type 316
Bonnet	Stainless Steel	A-351, Grade CF8M
Wedge	Stainless Steel	A-351, Grade CF8M
Body	Stainless Steel	A-351, Grade CF8M

ORDERING

- Other Alloys are available on special order
- Socket Welding End valves use Threaded End figure number with suffix S.W.E.

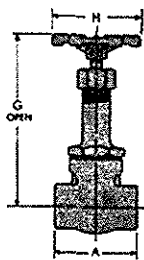

Fig. 1832

DIMENSIONS (Inches)

Size	1/4	3/8	1/2	3/4	1	1 1/4	1 1/2	2
A (T.E., S.W.E.)	1 3/4	2	2 1/4	2 1/2	3 1/4	3 1/2	3 3/4	4
G	4 9/16	4 9/16	5 1/4	6 11/16	7 13/16	9 1/4	10 1/2	12 5/8
H	2 1/2	2 1/2	2 3/4	3	3 1/4	3 5/8	4 1/16	4 3/4

WEIGHTS (Pounds)

Fig. 1832	.8	.8	1.3	2.1	3.3	4.5	6.2	10.4
-----------	----	----	-----	-----	-----	-----	-----	------

CORROSION RESISTANT GATE VALVES

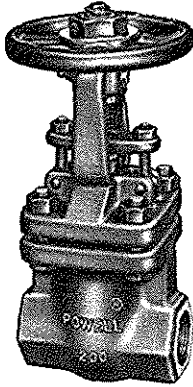

Class 200
Threaded
Sizes, 1/4" through 2"
Solid Wedge Fig. 2490
Split Wedge Fig. 2494

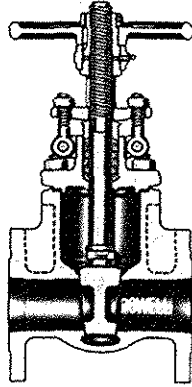

Class 150
Flanged
Sizes, 1/2" through 2"
Fig. 2491
Fig. 2495

For Sizes, 2 1/2" through 48"
See Fig. 2456, page 84

FEATURES

- Fully guided Solid Wedge
- Integral Seats
- Yoke bushing can be lubricated to minimize friction and prolong life of the stem
- Gasket completely nested in the valve neck flange
- Valves are available with Socket or Butt Welding Ends
- Split Wedges are available on order and are interchangeable with Solid Wedges

CLASS 150-200 BOLTED FLANGED YOKE-BONNET OUTSIDE SCREW RISING STEM THREADED and FLANGED ENDS

PRESSURE/TEMPERATURE RATINGS
In accordance with ASME B16.34

MATERIALS

DESCRIPTION	MATERIAL	ASTM Spec.
Yoke Bushing	Stainless Steel	A-582, Type 416
Yoke Bushing Locknut	Stainless Steel	A-582, Type 416
Headless Set Screw	Steel	Commercial
Identification Plate	Aluminum	Commercial
Handwheel	Malleable Iron	A-47, Grade 32510
Handwheel Key	Steel	Commercial
Yoke	Stainless Steel	A-351, Grade CF8M
Lubricant Fitting	Steel	Commercial
Stem	Stainless Steel	A-276, Type 316
Gland Eyebolt Nut	Stainless Steel	300 Series
Gland Eyebolt	Stainless Steel	300 Series
Gland Eyebolt Pin	Stainless Steel	300 Series
Gland Flange	Stainless Steel	300 Series
Packing	PTFE	Commercial
Yoke Bolt	Stainless Steel	A-193, Grade B8
Yoke Bolt Nut	Stainless Steel	A-194, Grade 8
Gasket	PTFE	Commercial
Body (F.E.)	Stainless Steel	A-351, Grade CF8M
Body (T.E., S.W.E., B.W.E.)	Stainless Steel	A-351, Grade CF3M
Wedge	Stainless Steel	A-351, Grade CF8M
Gland Follower	Stainless Steel	A-276, Type 316

SPECIFICATIONS

- Flanges End valves have end flanges in accordance with ASME B16.5
- Face-to-face dimensions conform to ASME B16.10

ORDERING

- Other Alloys are available on special order
- Socket Welding End valves use Threaded End figure number with suffix S.W.E.
- Butt Welding End valves use Flanged End figure number with suffix B.W.E.
- When ordering Butt Welding End valves, specify schedule of tubing or pipe end, and give complete data concerning style, figure number and contour of weld ends

DIMENSIONS (Inches)

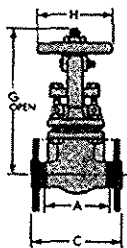

Fig. 2490
Fig. 2491

Size	1/4	3/8	1/2	3/4	1	1 1/4	1 1/2	2	2 1/2 through 48*
A	2 1/8	2 1/8	3	3 1/2	4	4 5/8	4 5/8	5	FOR
C	-	-	4 1/4	4 5/8	5	5 1/2	6 1/2	7"	DATA
G	6 1/2	6 1/2	7 13/16	8 5/8	9 7/16	10 3/4†	12 1/8	14 1/4	SEE
H	3	3	3 1/2	4	4 1/2	5‡	6	7	PAGE 84
	† 12 1/8 for (T.E., S.W.E.)		* 8 1/2 for (B.W.E.)		‡ 6 for (T.E., S.W.E.)				

WEIGHTS (Pounds)

Fig. 2490	3	3.5	4.8	6.5	9	14.4	18	24.3
Fig. 2491	-	-	6	8.4	12.5	18.4	23.9	33.9

CORROSION RESISTANT GATE VALVES

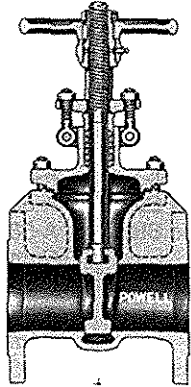

Fig. 2456
One-piece Yoke
Sizes, 2 1/2" through 10"

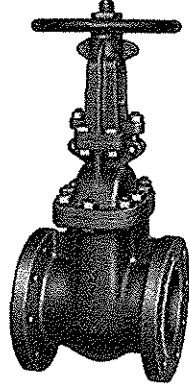

Fig. 2456
Separate Yoke Arms
Sizes, 12" through 48"

Above 24" Data on Request

FEATURES

- Flexible Wedge sizes 3" through 48"
- Integral Seats
- Separate yoke arms are furnished on valve sizes 12" through 48"
- Butt Welding End valves are available on order
- Other alloys are available on special order

ORDERING

- Butt Welding End valves use Flanged End figure number with suffix B.W.E.
- When ordering Butt Welding End valves, specify schedule of tubing or pipe end, and give complete data concerning style, figure number and contour of weld ends

CLASS 150 BOLTED FLANGED YOKE-BONNET OUTSIDE SCREW RISING STEM FLANGED ENDS

PRESSURE/TEMPERATURE RATINGS
In accordance with ASME B16.34

MATERIALS

DESCRIPTION	MATERIAL	ASTM Spec.
Stem Bushing Nut (8" & Up)	Malleable Iron	A-47, Grade 32510
Handwheel Key	Steel	Commercial
Handwheel	Malleable Iron	A-47, Grade 32510
Stem Bushing (6" & Up)	Bronze	B-62
Lubricant Fitting	Steel	Commercial
Yokearm Bolts*	Stainless Steel	A-582, Type 303
Yokearm*	Stainless Steel	A-351, Grade CF8M
Yokearm Nuts*	Stainless Steel	A-276, Type 316
Eyebolt	Stainless Steel	300 Series
Gland Flange	Stainless Steel	300 Series
Eyebolt Nut	Stainless Steel	300 Series
Gland Follower	Stainless Steel	A-276, Type 316
Packing	PTFE	Commercial
Gasket	PTFE***	Commercial
Stem	Stainless Steel	A-276, Type 316
Body (F.E.)	Stainless Steel	A-351, Grade CF8M
(B.W..E.)	Stainless Steel	A-351, Grade CF8M
Wedge	Stainless Steel	A-351, Grade CF8M
Stem Bushing (2 1/2"-6")	Stainless Steel	A-582, Type 416
Stem Bushing Locknut (2 1/2"-6")	Stainless Steel	A-582, Type 416
Headless Set Screw**	Steel	Commercial
Identification Plate**	Aluminum	Commercial
Yoke	Stainless Steel	A-351, Grade CF8M
Eyebolt Pin	Stainless Steel	300 Series
Body/Yoke Bolt	Stainless Steel	A-193, Grade B8
Body Yoke Nuts	Stainless Steel	A-194, Grade 8

* 12" and Up

** 2 1/2" through 10"

*** 8" and larger, glass filled PTFE

SPECIFICATIONS

- Flanges valves have end flanges in accordance with ASME 16.5
- Face-to-face dimensions conform to ASME B16.10

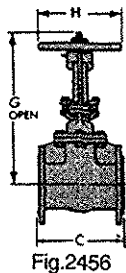

DIMENSIONS (Inches)

Size	1/4 to 2	2 1/2	3	4	6	8	10	12	14	16	18	20	24	30 thru 48
C (F.E.)	see	7 1/2	8	9	10 1/2	11 1/2	13	14	15	16	17	18	20	DATA
C (B.W.E.)	page	9 1/2	11 1/8	12	15 7/8	16 1/2	18	19 3/4	22 1/2	24	26	28	32	ON
G	83	14 7/16	16 1/8	20	28 1/16	37 1/2	48 1/4	57 3/4	64	74 3/8	84 5/16	92	99	REQUEST
H		7	7	9	11	14	16	18	22	22	24	24	26	

WEIGHTS (Pounds)

Fig. 2456	39.1	52	88	146	224	332	464	650	862	1550	2000	2650
-----------	------	----	----	-----	-----	-----	-----	-----	-----	------	------	------

CORROSION RESISTANT GATE VALVES

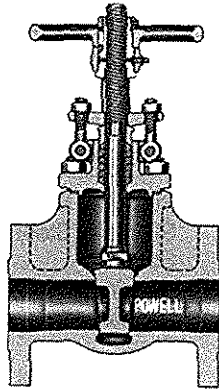

Fig. 2467

Flanged
Sizes, 1/2" through 30"
Above 12" Data on Request

Fig. 2466

Threaded
Sizes, 1/4" through 2"

ORDERING

- Other Alloys are available on special order
- Socket Welding End valves use Threaded End figure number with suffix S.W.E.
- Butt Welding End valves use Flanged End figure number with suffix B.W.E.
- When ordering Butt Welding End valves specify schedule of tubing or pipe end, give complete data concerning style, figure number and contour of weld ends

CLASS 300

BOLTED FLANGED YOKE-BONNET OUTSIDE SCREW RISING STEM THREADED and FLANGED ENDS

PRESSURE/TEMPERATURE RATINGS

In accordance with ASME B16.34

MATERIALS

DESCRIPTION	MATERIAL	ASTM Spec.
Body (F.E.)	Stainless Steel	A-351, Grade CF8M
Body (T.E., S.W.E., B.W.E.)	Stainless Steel	A-351, Grade CF3M
Bonnet	Stainless Steel	A-351, Grade CF8M
Yokearm (8" & Up)	Stainless Steel	A-351, Grade CF8M
Gland	Stainless Steel	A-276, Type 316
Wedge	Stainless Steel	A-351, Grade CF8M
Stem	Stainless Steel	A-276, Type 316
Handwheel	Malleable Iron	A-47, Grade 32510
Stem Bushing (8" & Up) (1/4" - 6")	Bronze	B-62
Stem Bushing Nut (1/4" - 6") (8" & Up)	Stainless Steel	A-582, Type 416
Stem Bushing Nut (1/4" - 6") (8" & Up)	Malleable Iron	A-47, Grade 32510
Handwheel Key	Steel	Commercial
Gasket	PTFE	Commercial
Packing	PTFE	Commercial
Lubricant Fitting	Steel	Commercial
Gland Flange	Stainless Steel	300 Series
Yokearm Bolts (8" & Up)	Stainless Steel	300 Series
Yokearm Nuts (8" & Up)	Stainless Steel	300 Series
Eyebolts	Stainless Steel	300 Series
Eyebolts Nuts	Stainless Steel	300 Series
Body Studs	Stainless Steel	A-193, Grade B8
Body Nuts	Stainless Steel	A-194, Grade 8
Groov-Pin	Stainless Steel	300 Series

SPECIFICATIONS

- Flanged valves have end flanges in accordance with ASME B16.5
- Face-to-face dimensions conform to ASME B16.10

FEATURES

- Fully guided Flexible Wedge sizes 3" through 12"
- Integral Seat
- Socket and Butt Welding End valves are available

DIMENSIONS (Inches)

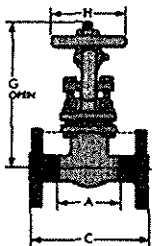

Fig. 2466
Fig. 2467

Size	1/4	3/8	1/2	3/4	1	1 1/4	1 1/2	2	2 1/2	3	4	6	8	10	12	14 thru 30
A (T.E., S.W.E.)	2 1/8	2 1/8	3	3 1/2	4	4 5/8	4 5/8	5	-	-	-	-	-	-	-	-
C (F.E., B.W.E.)	-	-	5 1/2	6	6 1/2	7	7 1/2	8 1/2	9 1/2	11 1/8	12	15 7/8	16 1/2	18	19 3/4	DATA
G	6 1/2	6 1/2	7 7/8	8 7/8	9 7/16	10 3/4	12 1/8	14 1/4	14 7/16	16 1/8	20	28 9/16	39 3/8	49 1/4	57 7/8	ON REQUEST
H	3	3	3 1/2	4	4 1/2	5†	6	7	7	9	10	14	17	22	22	

† 6 for (T.E., S.W.E.)

WEIGHTS (Pounds)

Fig. 2466	3.4	3.4	4.6	6.1	9.1	13.5	18	28.9	-	-	-	-	-	-	-	-
Fig. 2467	-	-	7.3	11.2	15.4	27.2	33.1	37.5	50.4	95	157	270	420	705	1020	

CORROSION RESISTANT GATE VALVES

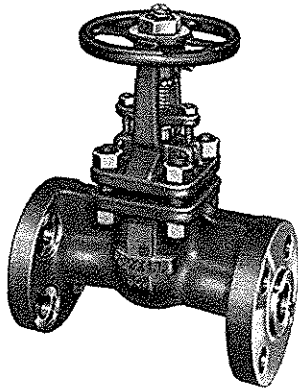

Fig. 1973

Flanged
Sizes, 1/2" through 24"
Above 2" Data on Request

Fig. 1972

Threaded
Sizes, 1/4" through 2"

ORDERING

- Socket Welding End valves use Threaded End Figure number with suffix S.W.E.
- Butt welding End valves use Flanged End figure number with suffix B.W.E.
- When ordering Butt Welding End valves specify schedule of tubing or pipe end, and give complete data concerning style, figure number and contour of weld ends

CLASS 600 BOLTED FLANGED YOKE-BONNET OUTSIDE SCREW RISING STEM THREADED and FLANGED ENDS

PRESSURE/TEMPERATURE RATINGS

In accordance with ASME B16.34

MATERIALS

DESCRIPTION	MATERIAL	ASTM Spec.
Yoke Bushing	Stainless Steel	A-582, Type 416
Yoke Bushing Locknut	Stainless Steel	A-582, Type 416
Headless Set Screw	Steel	Commercial
Identification Plate	Aluminum	Commercial
Handwheel	Malleable Iron	A-47, Grade 32510
Handwheel Key	Steel	Commercial
Yoke	Stainless Steel	A-351, Grade CF8M
Lubricant Fitting	Steel	Commercial
Stem	Stainless Steel	A-276, Type 316
Gland Eyebolt Nut	Stainless Steel	300 Series
Gland Eyebolt	Stainless Steel	300 Series
Gland Eyebolt Pin	Stainless Steel	300 Series
Gland Flange	Stainless Steel	300 Series
Packing	PTFE	Commercial
Yoke Stud	Stainless Steel	A-193, Grade B8*
Yoke Stud Nut	Stainless Steel	A-194, Grade 8
Gasket	PTFE**	Commercial
Body (F.E.)	Stainless Steel	A-351, Grade CF8M
Body (T.E. & W.E.)	Stainless Steel	A-351, Grade CF3M
Wedge	Stainless Steel	A-351, Grade CF8M
Gland Follower	Stainless Steel	A-276, Type 316

* Class 2 (strain hardened) Bolting for 1/2" and smaller sizes

** Spiral wound with Type 316 Stainless Steel with PTFE filler

SPECIFICATIONS

- Flanged valves have end flanges in accordance with ASME B16.5
- Face-to-face dimensions conform to ASME B16.10

FEATURES

- Fully guided Solid Wedge
- Integral Seats
- Other alloys are available on special order
- Valves can be furnished with Socket or Butt Welding Ends

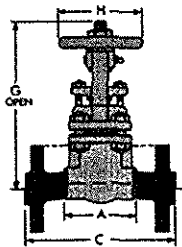

Fig. 1972
Fig. 1973

DIMENSIONS (Inches)

Size	1/4	3/8	1/2	3/4	1	1 1/4	1 1/2	2	2 1/2' through 24'
A (T.E., S.W.E.)	2 1/8	2 1/8	3	3 1/2	4	4 1/2	5	5 3/4	DATA
C (F.E., B.W.E.)	-	-	6 1/2	7 1/2	8 1/2	9	9 1/2	11 1/2	ON
G	6 5/8	6 5/8	7 15/16	8 7/8	9 3/4	11 1/16	12 7/16	14 1/4	REQUEST
H	3	3	3 1/2	4	5	6	7	8	

WEIGHTS (Pounds)

Fig. 1972	3.6	4.3	5.1	7.1	10.6	16	21.3	32	
Fig. 1973	-	-	8.3	15	20.9	26.5	38.1	42	

CORROSION RESISTANT GLOBE VALVE

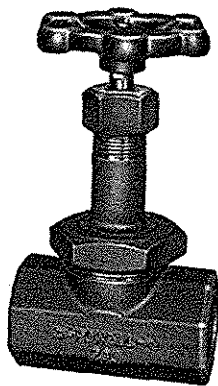
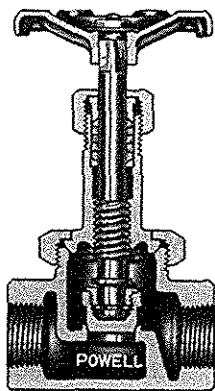

Fig. 1861
Threaded
Sizes, 1/4" through 2"

CLASS 200 UNION BONNET THREADED ENDS

PRESSURE/TEMPERATURE RATINGS
In accordance with ASME B16.34

MATERIALS

DESCRIPTION	MATERIAL	ASTM Spec.
Handwheel Nut	Steel	Commercial
Identification Plate	Aluminum	Commercial
Handwheel	Malleable Iron	A-47, Grade 32510
Stem	Stainless Steel	A-276, Type 316
Packing Gland	Stainless Steel	A-276, Type 316
Packing Nut	Stainless Steel	A-276, Type 316
Packing	PTFE	Commercial
Packing Collar	Stainless Steel	A-276, Type 316
Bonnet	Stainless Steel	A-351, Grade CF8M
Bonnet Ring	Stainless Steel	A-351, Grade CF8M
Disc Locknut	Stainless Steel	A-276, Type 316
Horse Shoe Ring†	Stainless Steel	A-582, Type 303
Disc	Stainless Steel	A-276, Type 316
Body	Stainless Steel	A-351, Grade CF3M

† 1/4 to 1 incl.

FEATURES

- Plug type disc; however, valves can be furnished with special discs on special order
- Integral Seats
- Socket Welding end valves can be furnished on order

ORDERING

- Socket Welding End valves use Threaded End figure number with suffix S.W.E.
- When ordering Socket Welding End valves, specify schedule of tubing or pipe end, and give complete data concerning style, figure number and contour of weld ends

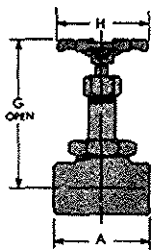

Fig. 1861

DIMENSIONS (Inches)

Size	1/4	3/8	1/2	3/4	1	1 1/4	1 1/2	2
A	2 7/16	2 7/16	2 7/16	3 3/8	3 3/8	5 1/2	5 1/2	6
G	4 3/8	4 3/8	4 3/8	5 27/32	5 27/32	8 12/16	8 1/16	9 1/8
H	2 3/4	2 3/4	2 3/4	3 1/4	3 1/4	4 1/16	4 1/16	4 3/4

WEIGHTS (Pounds)

Fig. 1861	1.1	1.1	1.1	2.7	4.9	8.8	9.8	12.4
-----------	-----	-----	-----	-----	-----	-----	-----	------

CORROSION RESISTANT GLOBE VALVES

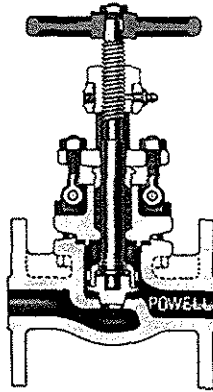

Fig. 2475
(Class 150)

Flanged
Sizes, 1/2" through 2 1/2"
Sizes, 3" through 24"
See Page 89

Fig. 2474
(Class 200)

Threaded
Sizes, 1/4" through 3"

ORDERING

- Socket Welding End valves use Threaded End figure number with suffix S.W.E.
- When ordering Socket Welding End valves, specify schedule of tubing or pipe end, and give complete data concerning style, figure number and contour of weld ends

CLASS 150-200

BOLTED FLANGED YOKE-BONNET OUTSIDE SCREW RISING STEM THREADED and FLANGED ENDS

PRESSURE/TEMPERATURE RATINGS

In accordance with ASME B16.34

MATERIALS

DESCRIPTION	MATERIAL	ASTM Spec
Handwheel Nut	Steel	Commercial
Identification Plate	Aluminum	Commercial
Handwheel	Malleable Iron	A-47, Grade 32510
Stem	Stainless Steel	A-276, Type 316
Yoke Bushing	Stainless Steel	A-582, Type 416
Headless Set Screw	Steel	Commercial
Yoke	Stainless Steel	A-351, Grade CF8M
Gland Eyebolt Nut	Stainless Steel	300 Series
Gland Eyebolt	Stainless Steel	300 Series
Gland Eyebolt Pin	Stainless Steel	300 Series
Gland Flange	Stainless Steel	300 Series
Gland Follower	Stainless Steel	A-276, Type 316
Packing	PTFE	Commercial
Yoke Bolt Nut	Stainless Steel	A-194, Grade 8
Yoke Bolt	Stainless Steel	A-193, Grade B8
Gasket	PTFE	Commercial
Disc Locknut	Stainless Steel	A-276, Type 316
Disc	Stainless Steel	A-276, Type 316
Body (F.E.)	Stainless Steel	A-351, Grade CF8M
Body (T.E., S.W.E., B.W.E.)	Stainless Steel	A-351, Grade CF3M

SPECIFICATIONS

- Flanged valves have end flanges in accordance with ASME B16.5
- Face-to-face dimensions conform to ASME B16.10

FEATURES

- Plug type disc; however, special discs are available on order.
- Other alloys are available on special order
- Socket and Butt Welding End valves are available

DIMENSIONS (Inches)

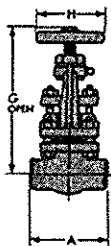

Fig. 2474

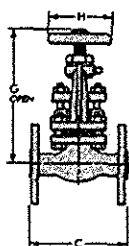

Fig. 2475

Size	1/4	3/8	1/2	3/4	1	1 1/4	1 1/2	2	2 1/2	3*	4 thru 24
A (T.E., S.W.E.)	2 7/8	2 7/8	2 7/8	3 1/4	3 3/4	5 1/2	5 1/2	6	6 3/4	8	See Page 89
C (F.E., B.W.E.)	-	-	4 1/4	4 5/8	5	5 1/2	6 1/2	8	8 1/2		
G	6 3/4	6 3/4	6 3/4	7 5/16	8 3/16	8 7/8†	9 7/8	10 7/8	12 1/4	14 1/8	
H	3	3	3	3 1/2	4	4 1/2‡	5	6	7	8	

† 9 7/8 (TE, WE)
‡ 5 (TE, WE)

WEIGHTS (Pounds)

Fig. 2474	3.5	3.5	3.5	4.5	6.7	10.5	13.7	19.8	27.4	40.4
Fig. 2475	-	-	5	6.5	9.3	14.7	20	29.5	40	

* for 3" 2475, see page 89

CORROSION RESISTANT GLOBE VALVES

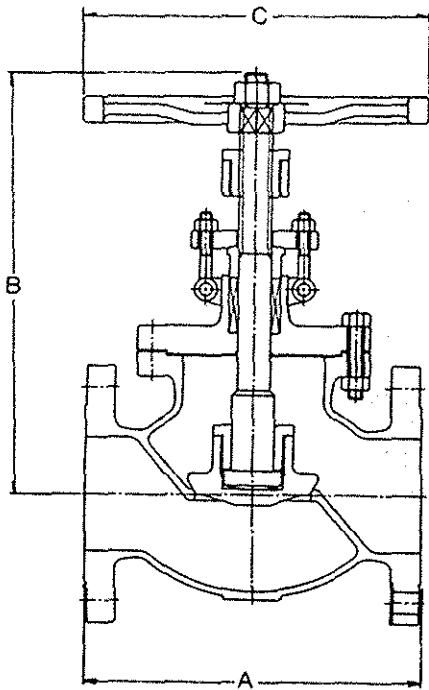

Fig. 2475
Sizes, 3" & 4"

Fig. 2629
Sizes, 6" through 24"

Above 12" Data on Request

ORDERING

- Butt Welding End valves use Flanged End figure number with suffix B.W.E.

CLASS 150 BOLTED FLANGED YOKE-BONNET OUTSIDE SCREW RISING STEM FLANGED ENDS

PRESSURE/TEMPERATURE RATINGS
In accordance with ASME B16.34

MATERIALS

DESCRIPTION	MATERIAL	ASTM Spec
Body (F.E.)	Stainless Steel	A-351, Grade CF8M
Body (W.E.)	Stainless Steel	A-351, Grade CF3M
Bonnet	Stainless Steel	A-351, Grade CF8M
Disc	Stainless Steel	A-351, Grade CF8M
Stem	Stainless Steel	A-276, Type 316, or A-182, Grade F316
Handwheel	Ductile Iron	A-536, Grade 65-45-12
Gland Flange	Stainless Steel	300 Series
Gland Follower	Stainless Steel	A-182, Grade F316
Disc Locknut	Stainless Steel	A-351, Grade CF8M
Yoke Bushing	Ductile Iron	A-439, Grade D2C
Bonnet Bolt	Stainless Steel	A-193, Grade B8
Bonnet Nut	Stainless Steel	A-194, Grade 8
Gland Eyebolt	Stainless Steel	300 Series
Gland Nut	Stainless Steel	300 Series
Gland Eyebolt Pin	Stainless Steel	300 Series
Wheel Nut	Stainless Steel	A-194, Grade 8
Name Plate	Stainless Steel	A-240, Grade 304
Packing	PTFE	Commercial
Gasket	PTFE	Sheet

SPECIFICATIONS

- Flanged valves have end flanges in accordance with ASME B16.5
- Face-to-face dimensions conform to ASME B16.10

FEATURES

- Other alloys are available on special order

DIMENSIONS (Inches)

Size	1/4 to 2 1/2	3	4	6	8	10	12	14 through 24
A. Face to Face R.F.	see	9 1/2	11 1/2	16	19 1/2	24 1/2	27 1/2	DATA ON
A. Face to Face B.W.E.	page	9 1/2	11 1/2	16	19 1/2	24 1/2	27 1/2	REQUEST
B. Valve Open	88	14 7/8	17 3/4	20 1/4	22 3/4	29 3/8	32 3/4	
C. Hand Wheel Dia		10	12	14	16	22	22	
Weight(Lbs) F.E.		71	109	173	323	565	1105	

CORROSION RESISTANT GLOBE VALVES

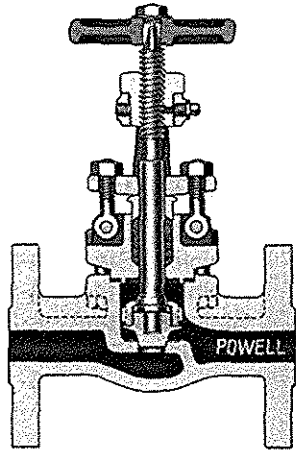

Fig. 2447

Flanged
Sizes, 1/2" through 2 1/2"
Sizes, 3" through 16"
See Page 91

Fig. 2446

Threaded
Sizes, 1/4" through 3"

ORDERING

- Socket Welding End valves use Threaded End figure number with suffix S.W.E.
- Butt Welding End valves use Flanged End figure number with suffix B.W.E.
- When ordering Butt Welding End valves, specify schedule of tubing or pipe end, give complete data concerning style, figure number and contour of weld ends

CLASS 300 BOLTED FLANGED YOKE-BONNET OUTSIDE SCREW RISING STEM THREADED and FLANGED ENDS

PRESSURE/TEMPERATURE RATINGS

In accordance with ASME B16.34

MATERIALS

DESCRIPTION	MATERIAL	ASTM Spec
Handwheel Nut	Steel	Commercial
Identification Plate	Aluminum	Commercial
Handwheel	Malleable Iron	A-47, Grade 32510
Stem	Stainless Steel	A-276, Type 316
Yoke Bushing	Stainless Steel	A-582, Type 416
Headless Set Screw	Steel	Commercial
Yoke	Stainless Steel	A-351, Grade CF8M
Gland Eyebolt Nut	Stainless Steel	300 Series
Gland Eyebolt	Stainless Steel	300 Series
Gland Eyebolt Pin	Stainless Steel	300 Series
Gland Flange	Stainless Steel	300 Series
Gland Follower	Stainless Steel	A-276, Type 316
Packing	PTFE	Commercial
Yoke Bolt Nut	Stainless Steel	A-194, Grade 8
Yoke Bolt	Stainless Steel	A-193, Grade B8
Gasket	PTFE	Commercial
Disc Locknut	Stainless Steel	A-276, Type 316
Disc	Stainless Steel	A-276, Type 316
Body (F.E.)	Stainless Steel	A-351, Grade CF8M
Body (T.E., S.W.E., B.W.E.)	Stainless Steel	A-351, Grade CF3M

SPECIFICATIONS

- Flanged valves have end flanges in accordance with ASME B16.5
- Face-to-face dimensions conform to ASME B16.10

FEATURES

- Plug type disc; however, special discs are available on special order
- Integral Seats: renewable Seat Rings can be supplied on special order
- Other alloys are available on special order
- Socket and Butt Welding End valves are available

DIMENSIONS (Inches)



Fig. 2446

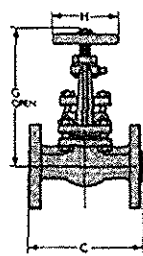

Fig. 2447

Size	1/4	3/8	1/2	3/4	1	1 1/4	1 1/2	2	2 1/2	3*	4 through 16
A (T.E., S.W.E.)	2 7/8	2 7/8	2 7/8	3 1/4	3 3/4	5 1/2	5 1/2	6	6 3/4	8	
C (F.E., B.W.E.)	-	-	6	7	8	8 1/2	9	10 1/2	11 1/2		See
G	6 3/4	6 3/4	6 3/4	7 5/16	8 3/16	8 7/8†	9 7/8	10 7/8	12 1/4	14 1/8	Page
H	3	3	3	3 1/2	4	4 1/2‡	5	6	7	8	91
	† 9 7/8 for (T.E., S.W.E.)		‡ 5 for (T.E., S.W.E.)								

WEIGHTS (Pounds)

Fig. 2446	3.6	3.6	3.8	4.6	7.1	13.5	19.1	25.8	34.6	51
Fig. 2447	-	-	6.5	11.3	13.1	16.4	25.3	34.1	50	

* for 3" 2447, see page 91

CORROSION RESISTANT GLOBE VALVES

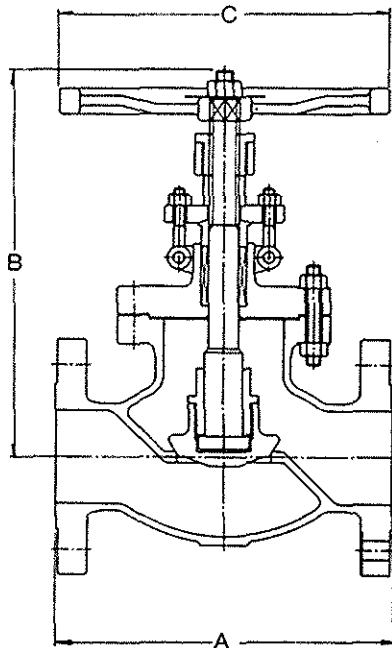

Fig. 2447
Sizes, 3" through 16"

ORDERING

- Butt Welding End valves use Flanged End figure number with suffix B.W.E.
- When ordering Butt Welding End valves specify schedule of tubing or pipe end, give complete data concerning style, figure number and contour of weld ends

CLASS 300 BOLTED FLANGED YOKE-BONNET OUTSIDE SCREW RISING STEM THREADED and FLANGED ENDS

PRESSURE/TEMPERATURE RATINGS

In accordance with ASME B16.34

MATERIALS

DESCRIPTION	MATERIAL	ASTM Spec
Body (F.E.)	Stainless Steel	A-351, Grade CF8M
Body (W.E.)	Stainless Steel	A-351, Grade CF3M
Bonnet	Stainless Steel	A-351, Grade CF8M
Disc	Stainless Steel	A-351, Grade CF8M
Stem	Stainless Steel	A-276, Type 316, or A-182, Grade F316
Handwheel	Ductile Iron	A-536, Grade 65-45-12
Gland Flange	Stainless Steel	300 Series
Gland Follower	Stainless Steel	A-182, Grade F316
Disc Locknut	Stainless Steel	A-351, Grade CF8M
Yoke Bushing	Ductile Iron	A-439, Grade D2C
Bonnet Bolt	Stainless Steel	A-193, Grade B8
Bonnet Nut	Stainless Steel	A-194, Grade 8
Gland Eyebolt	Stainless Steel	300 Series
Gland Nut	Stainless Steel	300 Series
Gland Eyebolt Pin	Stainless Steel	300 Series
Wheel Nut	Stainless Steel	A-194, Grade 8
Name Plate	Stainless Steel	A-240, Grade 304
Packing	PTFE	Commercial
Gasket	PTFE	Sheet

SPECIFICATIONS

- Flanged valves have end flanges in accordance with ASME B16.5
- Face-to-face dimensions conform to ASME B16.10

FEATURES

- Other alloys are available on special order
- Socket and Butt Welding End valves are available

DIMENSIONS (Inches)

Size	1/4 to 2	1/2	3	4	6	8	10	12	14 through 16
A. Face to Face R.F.	see	12 1/2	14	17 1/2	22	24 1/2	28		
A. Face to Face B.W.	page	12 1/2	14	17 1/2	22	24 1/2	28		DATA ON REQUEST
B. Valve Open	90	15 3/8	18 3/8	22 1/8	27 5/8	32 5/8	36 7/8		
C. Hand Wheel		10	12	16	22	22	22		
Weight(Lbs) F.E.		100	148	300	510	830	1435		

CORROSION RESISTANT GLOBE VALVES

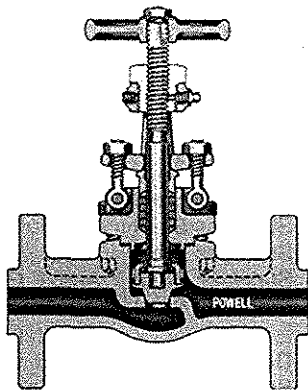

Fig. 1983
Flanged, Globe Valve
Sizes, 1/2" through 12"

Fig. 1982
Threaded, Globe Valve
Sizes, 1/4" through 2"

ORDERING

- Socket Welding End valves use Threaded End figure number with suffix S.W.E.
- Butt Welding End valves use Flanged End figure number with suffix B.W.E.
- When ordering Butt Welding End valves, specify schedule of tubing or pipe end, give complete data concerning style, figure number and contour of weld ends

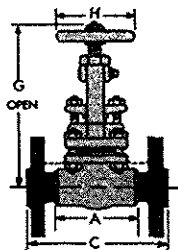

Fig. 1982
Fig. 1983

DIMENSIONS (Inches)

Size	1/4	3/8	1/2	3/4	1	1 1/4	1 1/2	2	3	4 through 12
A (T.E., S.W.E.)	2 7/8	2 7/8	2 7/8	3 1/4	3 3/4	5	5 5/8	6 1/4	-	DATA ON REQUEST
C (F.E., B.W.E.)	-	-	6 1/2	7 1/2	8 1/2	-	9 1/2	11 1/2	14	
G	6 3/4	6 3/4	6 3/4	7 5/16	8 5/16	10 1/16	10 7/8	12 3/4	17 7/16	
H	3	3	3	3 1/2	5	6	7	8	10	

WEIGHTS (Pounds)

Fig. 1982	3.7	3.7	3.8	4.8	7.4	17.5	21	40	-	
Fig. 1983	-	-	8.1	12.8	16.5		35.8	58	80	

CLASS 600 BOLTED FLANGED YOKE-BONNET OUTSIDE SCREW RISING STEM THREADED and FLANGED ENDS

PRESSURE/TEMPERATURE RATINGS

In accordance with ASME B16.34

MATERIALS

DESCRIPTION	MATERIAL	ASTM Spec
Handwheel Nut	Steel	Commercial
Identification Plate	Aluminum	Commercial
Handwheel	Malleable Iron	A-47, Grade 32510
Stem	Stainless Steel	A-276, Type 316
Yoke Bushing	Stainless Steel	A-582, Type 416
Lubricant Fitting	Steel	Commercial
Headless Set Screw	Steel	Commercial
Yoke	Stainless Steel	A-351, Grade CF8M
Gland Eyebolt Nut	Stainless Steel	300 Series
Gland Eyebolt	Stainless Steel	300 Series
Gland Eyebolt Pin	Stainless Steel	300 Series
Gland Flange	Stainless Steel	300 Series
Gland Follower	Stainless Steel	A-276, Type 316
Packing	PTFE	Commercial
Yoke Stud Nut	Stainless Steel	A-194, Grade 8
Yoke Stud	Stainless Steel	A-193, Grade B8*
Gasket	PTFE**	Commercial
Disc Locknut	Stainless Steel	A-276, Type 316
Disc	Stainless Steel	A-276, Type 316
Body (F.E.)	Stainless Steel	A-351, Grade CF8M
Body (T.E. & W.E.)	Stainless Steel	A-351, Grade CF3M

* Class 2 (Strain Hardened) Bolting for 3/4" and smaller sizes

** Spiral wound Type 316 Stainless Steel with PTFE filler

SPECIFICATIONS

- Flanged valves have end flanges in accordance with ASME B16.5
- Face-to-face dimensions conform to ASME B16.10

FEATURES

- Plug type disc; however, other discs are available on special order
- Integral Seats
- Other alloys are available on special order
- Socket and Butt Welding End valves are available

CORROSION RESISTANT NEEDLE GLOBE VALVES

SCREWED-IN BONNET THREADED ENDS

PRESSURE/TEMPERATURE RATINGS
3000 psi Non-Shock Cold Water, Oil or Gas

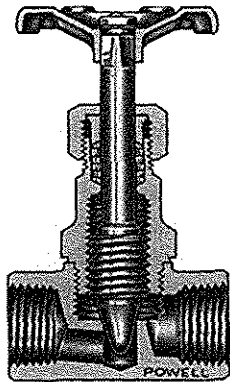

Fig. 1976
Sizes, 1/4" through 1"

SWING CHECK VALVES 200 WOG

SCREWED-IN CAP
PRESSURE/TEMPERATURE RATINGS
350°F Steam Pressure

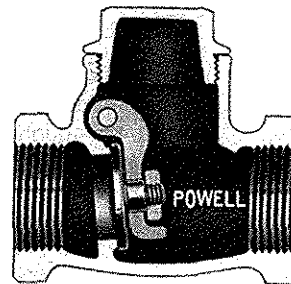

Fig. 1847
Sizes, 1/4" through 3"

MATERIALS

DESCRIPTION	MATERIAL	ASTM Spec
Handwheel Nut	Bronze	Commercial
Identification Plate	Aluminum	Commercial
Handwheel	Malleable Iron	A-47, Grade 32510
Stem	Stainless Steel	A-276, Type 316
Packing Gland	Stainless Steel	A-276, Type 316
Packing Nut	Stainless Steel	A-276, Type 316
Packing	PTFE	Commercial
Bonnet	Stainless Steel	A-276, Type 316
Body	Stainless Steel	A-276, Type 316*

* Alternate cast material
A-351, Grade CF8M

MATERIALS

DESCRIPTION	MATERIAL	ASTM Spec.
Cap	Stainless Steel	A-351, Grade CF8M
Carrier Plug	Stainless Steel	A-276, Type 316
Carrier Pin	Stainless Steel	A-276, Type 316
Disc	Stainless Steel	A-351, Grade CF8M
Body (T.E., S.W.E.)	Stainless Steel	A-351, Grade CF3M
Gaskets	PTFE	Commercial

DIMENSIONS (Inches) Fig. 1976

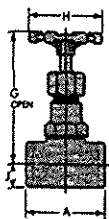

Fig. 1976

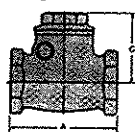

Fig. 1847

Size	1/4	3/8	1/2	3/4	1
A	1 7/8	2 1/2	2 1/2	3	3 1/2
J Center To Bottom-Globe	7/16	5/8	5/8	11/16	7/8
G Center To Top-Open	3	3 11/16	3 11/16	4 1/2	5 3/8
H Diameter of Wheel	2 1/8	2 1/2	2 1/2	3	3 1/4
Diameter of Seat Opening	3/16	1/4	1/4	3/8	1/2
WEIGHTS (Pounds) Fig. 1976	1	1.1	1.5	2.4	3.9

DIMENSIONS (Inches) Fig. 1847

Size	1/4	3/8	1/2	3/4	1	1 1/4	1 1/2	2	2 1/2	3
A	2 9/16	2 9/16	2 9/16	3 1/8	3 1/2	4 1/8	4 3/4	5 1/2	7 3/32	7 7/8
G	1 5/8	1 5/8	1 5/8	2	2 3/8	2 5/8	3	3 1/8	3 11/16	4 3/32
WEIGHTS (Pounds) Fig. 1847	.9	.9	.9	1.5	1.9	2.6	3.4	4.9	7.3	11.5

CORROSION RESISTANT SWING CHECK VALVES

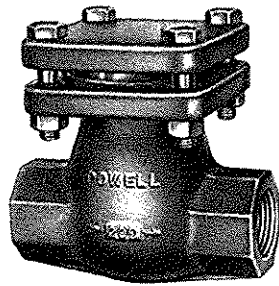

Fig. 2341
Threaded
Sizes, 1/4" through 2"
(Class 200)

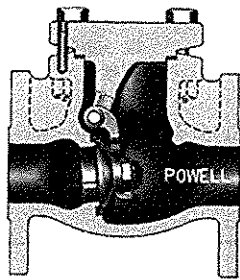

Fig. 2342
Flanged
Sizes, 1/2" through 8"
(Class 150)
Sizes 10" and up, see page 95

ORDERING

- When ordering Butt Welding End valves specify schedule of tubing or pipe end, and give complete data concerning style, figure number and contour of weld ends

CLASS 150-200 BOLTED FLANGED CAP THREADED and FLANGED ENDS

PRESSURE/TEMPERATURE RATINGS

In accordance with ASME B16.34

MATERIALS

DESCRIPTION	MATERIAL	ASTM Spec.
Cap Bolt	Stainless Steel	A-193, Grade B8
Cap Bolt Nut	Stainless Steel	A-194, Grade 8
Cap	Stainless Steel	A-351, Grade CF8M
Gasket	PTFE	Commercial
Carrier Pin	Stainless Steel	A-276, Type 316
Carrier	Stainless Steel	A-351, Grade CF8M
Disc Locknut	Stainless Steel	A-276, Type 316
Disc (1/4"-3/4")	Stainless Steel	A-276, Type 316
Disc (1"-8")	Stainless Steel	A-351, Grade CF8M
Body (F.E.)	Stainless Steel	A-351, Grade CF8M
Body (T.E. & W.E.)	Stainless Steel	A-351, Grade CF3M
Locating Pin	Stainless Steel	Commercial

SPECIFICATIONS

- Flanged valves have end flanges in accordance with ASME B16.5
- Face-to-face dimensions conform to ASME B16.10

FEATURES

- Disc suspended from valve cap and without side plugs
- Integral Seats, however, Renewable Screwed-In Seat Rings are available on order
- Cap has a male and female joint
- Valves can be used in horizontal or vertical position; however, when installed in vertical line, flow must be upward with pressure under the disc
- Other alloys are available on special order

DIMENSIONS (Inches)

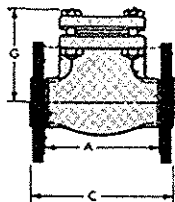

Fig. 2341
Fig. 2342

Size	1/4	3/8	1/2	3/4	1	1 1/2	2	3	4	6	8
A (T.E., S.W.E.)	2 3/4	2 3/4	2 3/4	3 3/4	4	5 1/2	6	-	-	-	-
C (F.E., B.W.E.)	-	-	4 1/4	4 5/8	5	6 1/2	8	9 1/2	11 1/2	14	19 1/2
G (T.E.)	2 5/32	2 5/32	2 5/32	3	3 3/8	4 1/16	4 9/16	-	-	-	-
G (T.E.)	-	-	2 5/16	3	3 3/8	4 1/16	4 9/16	5 9/16	6 1/8	7 13/16	9 5/8

WEIGHTS (Pounds)

Fig. 2341	2.1	2.1	2.1	3.3	4.9	10.6	15.5	-	-	-	-
Fig. 2342	-	-	3.6	5.3	7.5	14.6	24	48	72.9	128	-

CORROSION RESISTANT SWING CHECK VALVES

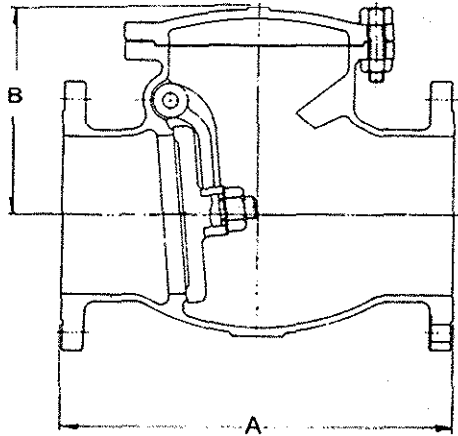

Fig. 2633

Sizes, 10" through 30"
 Sizes, 1/2" through 8",
 See Page 94

ORDERING

- When ordering Butt Welding End valves specify schedule of tubing or pipe end, and give complete data concerning style, figure number and contour of weld ends

CLASS 150 BOLTED FLANGED CAP FLANGED ENDS

PRESSURE/TEMPERATURE RATINGS
 In accordance with ASME B16.34

MATERIALS

DESCRIPTION	MATERIAL	ASTM Spec.
Body (F.E.)	Stainless Steel	A-351, Grade CF8M
Body (W.E.)	Stainless Steel	A-351, Grade CF3M
Cover	Stainless Steel	A-351, Grade CF8M
Disc	Stainless Steel	A-351, Grade CF8M
Hinge	Stainless Steel	A-351, Grade CF8M
Hinge Pin	Stainless Steel	A-182, Grade F316
Plug	Stainless Steel	A-193, Grade B8
Cover Bolt	Stainless Steel	A-193, Grade B8
Cover Nut	Stainless Steel	A-194, Grade 8
Disc Nut	Stainless Steel	A-194, Grade 8
Washer	Stainless Steel	A-276, Grade 316
Eye Bolt	Stainless Steel	A-193, Grade B8
Name Plate	Stainless Steel	A-240, Grade 304
Gasket	PTFE	Sheet

SPECIFICATIONS

- Flanged valves have end flanges in accordance with ASME B16.5
- Face-to-face dimensions conform to ASME B16.10

FEATURES

- Valves can be used in horizontal or vertical position; however, when installed in vertical line, flow must be upward with pressure under the disc
- Other alloys are available on special order

DIMENSIONS (Inches)

Size (In Inches)	10	12	14	16	18	20	24	30
A. Face to Face R.F.	24 1/2	27 1/2	31	34	38 1/2	38 1/2	51	60
A. Face to Face B.W.	24 1/2	27 1/2	31	34	38 1/2	38 1/2	51	60
B. Valve Height	13 1/4	15 5/8	17 1/2	20 1/2	22	23 1/4	27 5/8	34 1/4
Weight(Lbs)	365	505	655	1250	1550	1950	3440	4965

CORROSION RESISTANT SWING CHECK VALVES

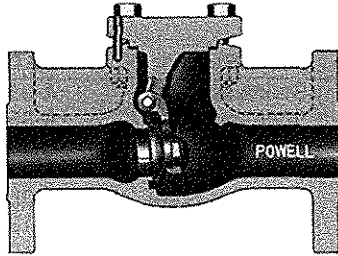

Fig. 2346
Flanged
Sizes, 1/2" through 24"
Above 8" Data on Request

Fig. 2345
Threaded
Sizes, 1/4" through 2"

ORDERING

•When ordering Butt Welding End valves specify schedule of tubing or pipe end, and give complete data concerning style, figure number and contour of weld ends

CLASS 300 BOLTED FLANGED CAP THREADED and FLANGED ENDS

PRESSURE/TEMPERATURE RATINGS
In accordance with ASME B16.34

MATERIALS

DESCRIPTION	MATERIAL	ASTM Spec.
Cap Bolt	Stainless Steel	A-193-B8
Cap Bolt Nut	Stainless Steel	A-194, Grade 8
Cap	Stainless Steel	A-351, Grade CF8M
Gasket	PTFE	Commercial
Carrier Pin	Stainless Steel	A-276, Type 316
Disc Locknut	Stainless Steel	A-276, Type 316
Disc (1/4"-3/4")	Stainless Steel	A-276, Type 316
Disc (1" & up)	Stainless Steel	A-351, Grade CF8M
Body (F.E.)	Stainless Steel	A-351, Grade CF8M
Body (T.E., S.W.E., B.W.E.)	Stainless Steel	A-351, Grade CF3M
Locating Pin (1/4"-8")	Stainless Steel	Commercial

SPECIFICATIONS

- Flanged valves have end flanges in accordance with ASME B16.5
- Face-to-face dimensions conform to ASME B16.10

FEATURES

- Disc suspended from valve cap and without side plugs
- Integral Seats, however, Renewable Screwed-In Seat Rings are available on order
- Cap has a male and female joint
- Valves can be used in horizontal or vertical position; however, when installed in vertical line, flow must be upward with pressure under the disc
- Other alloys are available on special order

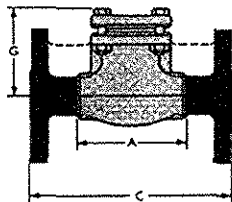

Fig. 2345

Fig. 2346

DIMENSIONS (Inches)

Size	1/4	3/8	1/2	3/4	1	1 1/2	2	3	4	6	8	10 thru 24
A (T.E., S.W.E.)	2 3/4	2 3/4	2 3/4	3 3/4	4	5 1/2	6	-	-	-	-	Data
C (F.E., B.W.E.)	-	-	6	7	8 1/2	9 1/2	10 1/2	12 1/2	14	17 1/2	21	On Request
G (T.E.)	2 5/32	2 5/32	2 5/32	3	3 3/8	4 1/16	4 9/16	-	-	-	-	Request
G (F.E.)	-	-	2 7/16	3 5/16	3 11/16	4 1/16	4 9/16	5 9/16	6 1/8	8 1/8	10 1/4	

WEIGHTS (Pounds)

Fig. 2345	2.2	2.2	4.4	6.1								
Fig. 2346	-	-		10.6	18	30	33.3	68	112	225	360	

CORROSION RESISTANT SWING CHECK VALVES

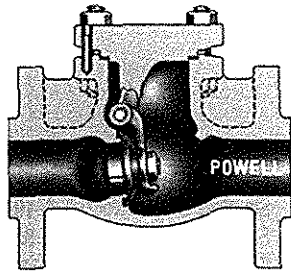

Fig. 2350
Flanged
Sizes, 1/2" through 18"
Above 3" Data on Request

Fig. 2349
Threaded
Sizes, 1/4" through 2"

ORDERING

•When ordering Butt Welding End valves specify schedule of tubing or pipe end, and give complete data concerning style, figure number and contour of weld ends

CLASS 600 BOLTED FLANGED CAP THREADED and FLANGED ENDS

PRESSURE/TEMPERATURE RATINGS
In accordance with ASME B16.34

MATERIALS

DESCRIPTION	MATERIAL	ASTM Spec.
Cap Stud	Stainless Steel	A-193-B8*
Cap Stud Nut	Stainless Steel	A-194, Grade 8
Cap	Stainless Steel	A-351, Gr. CF8M
Gasket	PTFE	**
Carrier Pin	Stainless Steel	A-276, Type 316
Carrier	Stainless Steel	A-351, Gr. CF8M
Disc Locknut	Stainless Steel	A-276, Type 316
Disc (1/4"-3/4")	Stainless Steel	A-276, Type 316
Disc (1" & up)	Stainless Steel	A-351, Gr. CF8M
Body (F.E.)	Stainless Steel	A-351, Gr. CF8M
Body (T.E., S.W.E., B.W.E.)	Stainless Steel	A-351, Gr. CF3M
Locating Pin (1/4"-8")	Stainless Steel	Commercial

* Class 2 (Strain hardened) Bolting for 3/4" and smaller sizes

** Spiral wound Type 316 Stainless Steel with PTFE filler

SPECIFICATIONS

- Flanged valves have end flanges in accordance with ASME B16.5
- Face-to-face dimensions conform to ASME B16.10

FEATURES

- Disc suspended from valve cap and without side plugs
- Integral Seats, however, Renewable Screwed-In Seat Rings are available on order
- Cap has a male and female joint
- Valves can be used in horizontal or vertical position; however, when installed in vertical line, flow must be upward with pressure under the disc
- Other alloys are available on special order

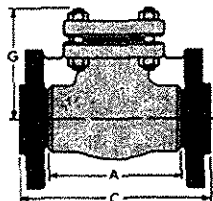

Fig. 2349
Fig. 2350

DIMENSIONS (Inches)

Size	1/4	3/8	1/2	3/4	1	1 1/2	2	3	4 Thru 18
A (T.E., S.W.E.)	2 3/4	2 3/4	2 3/4	3 3/4	4	5 5/8	6 1/4	-	Data
C (F.E., B.W.E.)	-	-	6 1/2	7 1/2	8 1/2	9 1/2	11 1/2	14	On
G (T.E.)	2 9/32	2 9/32	2 9/32	3 1/8	3 17/32	4 1/4	5 7/16	-	Request
G (F.E.)	-	-	2 1/2	3 13/32	3 27/32	4 1/4	5 7/16	6 13/16	

WEIGHTS (Pounds)

Fig. 2349	4.3	-	-	8.5	11	14.6	-	-	
Fig. 2350	-	-	10.4	-	23.8	-	52.4	83.7	

CORROSION RESISTANT HORIZONTAL LIFT CHECK VALVES

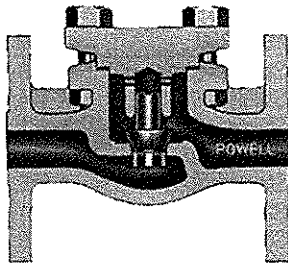

Fig. 2003
Flanged
Sizes, 1/2" through 3"
(Class 150)

Fig. 2002
Threaded
Sized, 1/4" through 3"
(Class 200)

ORDERING

- When ordering Butt Welding End valves specify schedule of tubing or pipe end, and give complete data concerning style, figure number and contour of weld ends

CLASS 150-200 BOLTED CAP THREADED and FLANGED ENDS

PRESSURE/TEMPERATURE RATINGS
In accordance with ASME B16.34

MATERIALS

DESCRIPTION	MATERIAL	ASTM Spec.
Cap Bolt	Stainless Steel	A-193, Grade B8
Cap Bolt Nut	Stainless Steel	A-194, Grade 8
Cap	Stainless Steel	A-351, Gr. CF8M
Gasket	PTFE	Commercial
Body (F.E.)	Stainless Steel	A-351, Gr. CF8M
Body (T.E., S.W.E., B.W.E.)	Stainless Steel	A-351, Gr. CF3M
Disc	Stainless Steel	A-276, Type 316

SPECIFICATIONS

- Flanged valves have end flanges in accordance with ASME B16.5
- Face-to-face dimensions conform to ASME B16.10

FEATURES

- Renewable Disc
- Integral Seat
- Bolted Caps with male and female joint
- Other alloys are available on special order

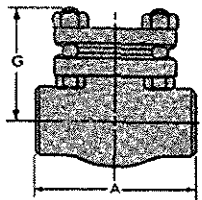

Fig. 2002

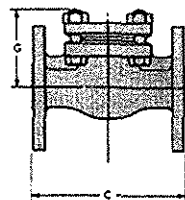

Fig. 2003

DIMENSIONS (Inches)

Size	1/4	3/8	1/2	3/4	1	1 1/4	1 1/2	2	2 1/2	3
A (T.E., S.W.E.)	2 7/8	2 7/8	2 7/8	3 1/4	3 3/4	5 1/2	5 1/2	6	6 3/4	8
C (F.E., B.W.E.)	-	-	4 1/4	4 5/8	5	5 1/2	6 1/2	8	8 1/2	9 1/2
G	2 3/16	2 3/16	2 3/16	2 5/16	2 5/8	3 1/32†	3 9/32	3 23/32	4 5/32	5 3/16

† 3 9/32 for (T.E., S.W.E.)

WEIGHTS (Pounds)

Fig. 2002	1.5	2	2.2	2.9	4.6	7.7	11	15.3	17.7	29.9
Fig. 2003	-	-	4.7	5.9	7.6	16.1	18.8	23.2	31	42.9

CORROSION RESISTANT HORIZONTAL LIFT CHECK VALVES

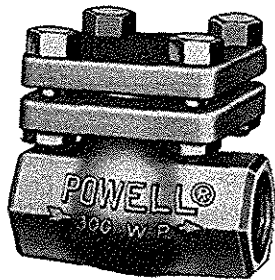

Fig. 2004
Threaded
Sizes, 1/4" through 3"

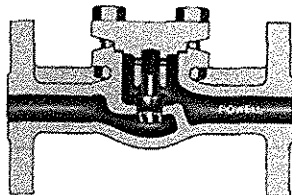

Fig. 2005
Flanged
Sizes, 1/2" through 3"

ORDERING

•When ordering Butt Welding End valves specify schedule of tubing or pipe end, and give complete data concerning style, figure number and contour of weld ends

CLASS 300 BOLTED CAP THREADED and FLANGED ENDS

PRESSURE/TEMPERATURE RATINGS
In accordance with ASME B16.34

MATERIALS

DESCRIPTION	MATERIAL	ASTM Spec.
Cap Bolt	Stainless Steel	A-193, Grade B8
Cap Bolt Nut	Stainless Steel	A-194, Grade 8
Cap	Stainless Steel	A-351, Gr. CF8M
Gasket	PTFE	Commercial
Body (F.E.)	Stainless Steel	A-351, Gr. CF8M
Body (T.E., S.W.E., B.W.E.)	Stainless Steel	A-351, Gr. CF3M
Disc	Stainless Steel	A-276, Type 316

SPECIFICATIONS

- Flanged valves have end flanges in accordance with ASME B16.5
- Face-to-face dimensions conform to ASME B16.10

FEATURES

- Renewable Disc
- Integral Seat
- Bolted Caps with male and female joint
- Other alloys are available on special order

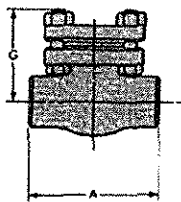

Fig. 2004

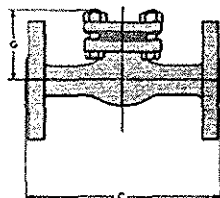

Fig. 2005

DIMENSIONS (Inches)

Size	1/4	3/8	1/2	3/4	1	1 1/4	1 1/2	2	2 1/2	3
A (T.E., S.W.E.)	2 7/8	2 7/8	2 7/8	3 1/4	3 3/4	5 1/2	5 1/2	6	6 3/4	8
C (F.E., B.W.E.)	-	-	6	7	8	8 1/2	9	10 1/2	11 1/2	12 1/2
G	2 3/16	2 3/16	2 3/16	2 5/16	2 5/8	3 1/32†	3 9/32	3 23/32	4 7/32	5 3/16

† 3 9/32 for (T.E., S.W.E.)

WEIGHTS (Pounds)

Fig. 2004	1.4	2	2.7	3.4	5.3	7.1	11	15.3	17.7	29.9
Fig. 2005	-	-	4.7	6.1	8.5	16.1	23.8	26.8	31	42.9

CORROSION RESISTANT HORIZONTAL LIFT CHECK VALVES

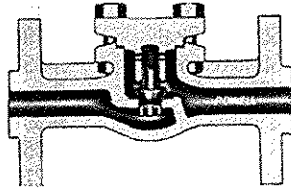

Fig. 2007
Flanged
Sizes, 1/2" through 2"

Fig. 2006-Threaded
Sizes, 1/4" through 2"

CLASS 600 BOLTED CAP THREADED and FLANGED ENDS PRESSURE/TEMPERATURE RATINGS In accordance with ASME B16.34

MATERIALS

DESCRIPTION	MATERIAL	ASTM Spec.
Cap Stud	Stainless Steel	A-193, Grade B8*
Cap Stud Nut	Stainless Steel	A-194, Grade 8
Cap	Stainless Steel	A-351, Gr. CF8M
Gasket	PTFE**	Commercial
Body (F.E.)	Stainless Steel	A-351, Gr. CF8M
Body (T.E., S.W.E., B.W.E.)	Stainless Steel	A-351, Gr. CF3M
Disc	Stainless Steel	A-276, Type 316

* Class 2 (Strain Hardened) Bolting

**Spiral wound Type 316 Stainless Steel with PTFE filler

ORDERING

- Socket Welding End valves use Threaded End figure number with suffix S.W.E.
- Butt Welding End valves use Flanged End figure number with suffix B.W.E.
- When ordering Butt Welding End valves specify schedule of tubing or pipe end, and give complete data concerning style, figure number and contour of weld ends

SPECIFICATIONS

- Flanged valves have end flanges in accordance with ASME B16.5
- Face-to-face dimensions conform to ASME B16.10

FEATURES

- Disc, accurately guided on top and bottom, is quickly renewable without removing valve from line
- Integral Seats
- Bolted Caps with male and female joint
- Socket and Butt Welding End valves are available
- Other alloys are available on special order

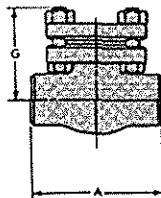
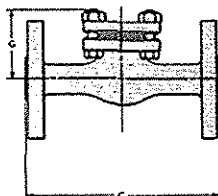

Fig. 2006



DIMENSIONS (Inches)

Size	1/4	3/8	1/2	3/4	1	1 1/4	1 1/2	2
A (T.E., S.W.E.)	2 7/8	2 7/8	2 7/8	3 1/4	3 3/4	5	6	7
C (F.E., B.W.E.)	-	-	6 1/2	7 1/2	8 1/2	-	9 1/2	11 1/2
G	2 3/8	2 3/8	2 3/8	2 19/32	2 31/32	3 15/16	4 3/16	5 9/16

WEIGHTS: On Application

CORROSION RESISTANT FLUSH BOTTOM TANK VALVES

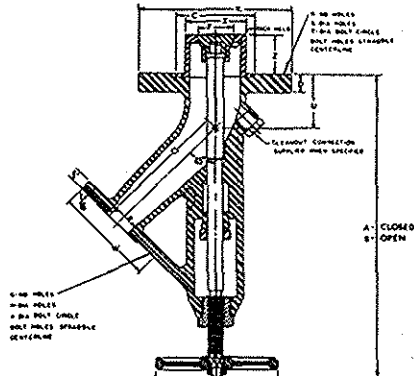

Fig. 2172 Disc opens (rises) into Tank

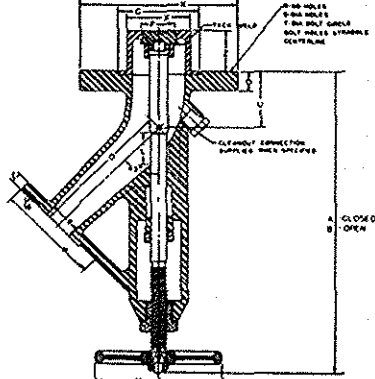

Fig. 2173 Disc opens (lowers) into Valve

CLASS 150

PRESSURE/TEMPERATURE RATINGS

In accordance with ASME B16.34

FEATURES

- Powell Flush Bottom Tank Valves are designed for the convenient and fast draining of metal tanks (with or without steam jackets), wood, glass or vitreous-lined tanks and autoclaves. The outlet is placed at an angle approximately 45° to the centerline of the valve
- These valves are made in stainless steel, nickel alloys and carbon steel
- Valves are made with full way area through valve body with minimum pressure drop

SPECIFICATIONS

- Outlet flanges have dimensions conforming to ASME B16.5

ORDERING

- Dimensions "X" and "Z", Powell Standard for outside diameter and height of the seat sleeve, will be supplied unless otherwise ordered
- When special dimensions are necessary, customer must specify
- Valve sizes are determined by outlet flange
- Tank Adaptor Pad, Studs, Bolts, Nuts and Gasket must be furnished and machined by customer, unless otherwise specified. Valves are regularly supplied with a boss (as illustrated). On special order boss can be drilled and tapped and plugged for internal flushing.

DIMENSIONS (Inches)...Fig. 2172

Size	A	B	C	D	E	F	G	H	J	K	O	P	R	S	T	U	V	W	X	Z
1/2	8 1/4	7 3/4	1 1/2	5/8	3/8	3/4	4	5/8	2 3/8	4 1/4	4	1/2	4	5/8	3 1/8	1 1/4	3 1/2	3 1/2	1 1/16	1 1/4
3/4	10 1/8	9	2 5/8	3/4	13/32	1	4	5/8	2 3/4	5	4 1/4	3/4	4	5/8	3 7/8	1 1/2	4	3 7/8	2	2
1	11 11/16	10 7/16	3 1/4	13/16	7/16	1 1/4	4	5/8	3 1/8	6	5 5/8	1	4	3/4	4 3/4	2 1/4	4 1/2	4 1/4	2 1/2	2
1 1/4	14 13/16	13 5/16	3 7/8	15/16	1/2	1 3/4	4	5/8	3 1/2	7 1/2	6 13/16	1 1/4	4	3/4	6	2 3/4	6	4 5/8	3	2
1 1/2	14 13/16	13 5/16	3 7/8	15/16	9/16	1 3/4	4	5/8	3 7/8	7 1/2	6 7/8	1 1/2	4	3/4	6	2 3/4	6	5	3	2
2	17 7/16	15 11/16	5	1 1/8	5/8	2 1/4	4	3/4	4 3/4	9	7 3/16	2	8	3/4	7 1/2	3 3/4	7	6	4	2
2 1/2	18 3/4	16 3/4	5 1/4	1 1/8	11/16	2 3/4	4	3/4	5 1/2	9	8 11/16	2 1/2	8	3/4	7 1/2	3 3/4	8	7	4 1/4	2
3	21 1/4	19 1/8	6 1/2	1 1/8	3/4	3 1/4	4	3/4	6	10	9 3/16	3	8	7/8	8 1/2	5 1/16	9	7 1/2	5 1/2	2

DIMENSIONS (Inches)...Fig. 2173

Size	A	B	C	D	E	F	G	H	J	K	O	P	R	S	T	U	V	W	X	Z
1/2	8 3/16	8 11/16	1 1/2	5/8	3/8	1/2	4	5/8	2 3/8	4 1/4	4	1/2	4	5/8	3 1/8	1 1/4	3 1/2	3 1/2	1 1/16	1 1/4
3/4	9 1/2	10 1/8	2 5/8	3/4	13/32	3/4	4	5/8	2 3/4	5	4 1/4	3/4	4	5/8	3 7/8	1 1/2	4	3 7/8	2	2
1	11 1/16	11 13/16	3 1/4	13/16	7/16	1	4	5/8	3 1/8	6	5 5/8	1	4	3/4	4 3/4	2 1/4	4 1/2	4 1/4	2 1/2	2
1 1/4	14 1/16	15 3/16	3 7/8	15/16	1/2	1 1/2	4	5/8	3 1/2	7 1/2	6 13/16	1 1/4	4	3/4	6	2 3/4	6	4 5/8	3	2
1 1/2	14 1/16	15 3/16	3 7/8	15/16	9/16	1 1/2	4	5/8	3 7/8	7 1/2	6 7/8	1 1/2	4	3/4	6	2 3/4	6	5	3	2
2	16 3/8	17 3/4	5	1 1/8	5/8	2	4	3/4	4 3/4	9	7 13/16	2	8	3/4	7 1/2	3 3/4	7	6	4	2
2 1/2	17 9/16	19 3/16	5 1/4	1 1/8	11/16	2 1/2	4	3/4	5 1/2	9	8 11/16	2 1/2	8	3/4	7 1/2	3 3/4	8	7	4 1/4	2
3	19 15/16	21 1/16	6 1/2	1 1/8	3/4	3	4	3/4	6	10	9 3/16	3	8	7/8	8 1/2	5 1/16	9	7 1/2	5 1/2	2

NOTE - Dimensions shown in Column "E" include 1/16" raised face.

WEIGHTS (Pounds)

Size	1/2	3/4	1	1 1/4	1 1/2	2	2 1/2	3
Fig. 2172-2173	7	11.3	17.3	-	32	51.4	68	78

CORROSION RESISTANT FLUSH BOTTOM TANK

CLASS 150

PRESSURE/TEMPERATURE RATINGS
In accordance with ASME B16.34

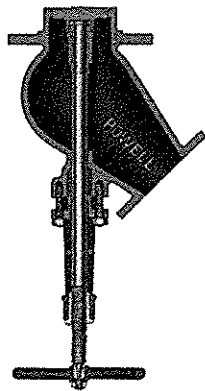

Fig. 2309
Disc opens into Tank

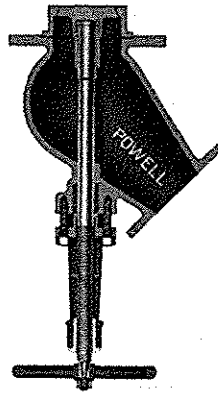

Fig. 2310
Disc opens into Valve

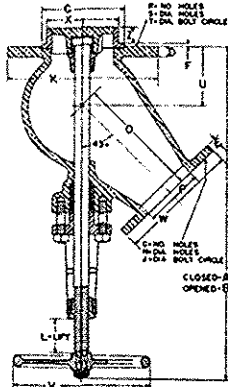

Fig. 2309
Disc opens into Tank

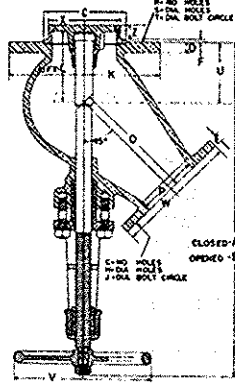

Fig. 2310
Disc opens into Valve

SPECIFICATIONS

- Outlet flanges have dimensions conforming to ASME B16.5

FEATURES

- These valves are designed so there are no pockets or dead areas in the vessel to entrap unmixed media or undissolved solids
- Valves for higher working pressures are available on special order
- Valves are available in Stainless Steels, Nickel Alloys, and Carbon Steel

ORDERING

- Tank Adaptor Pad, Studs, Bolts, Nuts and Gasket must be furnished and machined by customer, unless otherwise specified
- Dimensions "X" and "Z" are Powell Standard for outside diameter and height of the seat sleeve and will be supplied unless otherwise ordered. When special dimensions are necessary, customer must specify
- Valve sizes are determined by outlet flange

DIMENSIONS (Inches)...Fig. 2309

Sizes	A	B	C	D	E	F	G	H	J	K	L	O	P	R	S	T	U	V	W	X	Z
4	26 1/8	24 3/8	6 3/8	1 1/16	15/16	1/4	8	3/4	7 1/2	11	13/4	9 3/8	4	8	7/8	9 1/2	4 11/16	10	9	5 1/2	2
6	31 15/16	29 1/16	9 1/4	1 3/16	1	5/16	8	7/8	9 1/2	13 1/2	2 7/8	12 5/8	6	8	7/8	11 3/4	5 5/8	14	11	8 1/2	2
8	38 9/16	35 1/16	11 5/8	1 1/4	1 1/8	3/8	8	7/8	11 3/4	16	3 1/2	14 3/16	8	12	1	14 1/4	7 1/16	16	13 1/2	10	2 1/4
10	40 1/8	36 1/8	13 7/8	1 1/2	1 3/16	3/8	12	1	14 1/4	19	4	16	10	12	1	17	8	18	16	12 1/4	2 1/4

DIMENSIONS (Inches)...Fig. 2310

Sizes	A	B	C	D	E	F	G	H	J	K	L	O	P	R	S	T	U	V	W	X	Z
4	25	31 1/4	6 3/8	1 1/16	15/16	1/4	8	3/4	7 1/2	11	6 1/4	9 3/8	4	8	7/8	9 1/2	4 11/16	10	9	5 1/2	2
6	29 3/4	36 1/4	9 1/4	1 3/16	1	5/16	8	7/8	9 1/2	13 1/2	6 1/2	12 5/8	6	8	7/8	11 3/4	5 5/8	14	11	8 1/4	2
8	36 1/8	44 5/8	11 5/8	1 1/4	1 1/8	3/8	8	7/8	11 3/4	16	8 1/2	14 3/16	8	12	1	14 1/4	7 1/16	16	13 1/2	10	2 1/4
10	40	49 1/2	13 7/8	1 1/2	1 3/16	3/8	12	1	14 1/4	19	9 1/2	16	10	12	1	17	8	18	16	12 1/4	2 1/4

WEIGHTS (Pounds)

Fig. 2309-2310

Size	4	6	8	10
	110	220	350	

CORROSION RESISTANT FLUSH BOTTOM TANK VALVES

CLASS 300

PRESSURE/TEMPERATURE RATINGS
In accordance with ASME B16.34

SPECIFICATIONS

- Outlet flanges have dimensions conforming to ASME B16.5

FEATURES

- Powell Flush Bottom Tank Valves are designed for the convenient and fast draining of metal tanks (with or without steam jackets), wood, glass or vitreous-lined tanks and autoclaves. The outlet is placed at any angle approximately 45° to the center line of the valve
- These valves are made in Stainless Steel, Nickel Alloys and Carbon Steel
- Valves are made with fullway area through valve body with minimum pressure drop

ORDERING

- These valves are available on special order
- Dimensions "X" and "Z" are Powell Standard for outside diameter and height of the seat sleeve and will be supplied unless otherwise ordered. Where special dimensions are necessary, customer must specify
- Valve sizes are determined by outlet flange

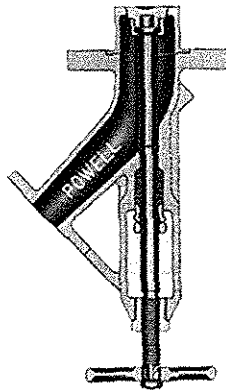

Fig. 2920
Disc opens into tank

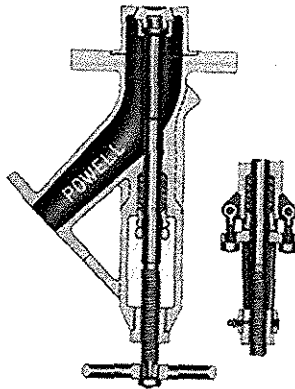

Fig. 2922
Disc opens into valve

DIMENSIONS (Inches) ...Fig. 2920

Sizes	A	B	C	D	E	F	G	H	J	K	O	P	R	S	T	U	V	W	X	Z
1/2	8 1/4	7 3/4	1 1/2	7/8	9/16	3/4	4	5/8	2 5/8	4 7/8	4 3/16	1/2	4	3/4	3 1/2	1 1/4	3 1/2	3 3/4	1 1/16	1 1/4
3/4	10 1/8	9	2 5/8	1	5/8	1	4	3/4	3 1/4	6 1/8	4 1/2	3/4	4	7/8	4 1/2	1 1/2	4	4 5/8	2	2
1	11 1/16	10 7/16	3 1/4	1 1/16	1 1/16	1 1/4	4	3/4	3 1/2	6 1/2	5 7/8	1	8	3/4	5	2 1/4	4 1/2	4 7/8	2 1/2	2
1 1/4	14 13/16	13 5/16	3 7/8	1 5/16	3/4	1 3/4	4	3/4	3 7/8	8 1/4	7 1/16	1 1/4	8	7/8	6 5/8	2 3/4	6	5 1/4	3	2
1 1/2	14 13/16	13 5/16	3 7/8	1 5/16	13/16	1 3/4	4	7/8	4 1/2	8 1/4	7 1/8	1 1/2	8	7/8	6 5/8	2 3/4	6	6 1/2	3	2
2	17 1/16	15 11/16	5	1 7/16	7/8	2 1/4	8	3/4	5	10	8 1/16	2	8	7/8	7 7/8	3 3/4	7	6 1/2	4	2
2 1/2	18 3/4	16 3/4	5 1/4	1 7/16	1	2 3/4	8	7/8	5 7/8	10	9	2 1/2	8	7/8	7 7/8	3 3/4	8	7 1/2	4 1/4	2
3	21 1/4	19 1/8	6 1/2	1 9/16	1 1/8	3 1/4	8	7/8	6 5/8	11	9 9/16	3	8	7/8	9 1/4	5 1/16	9	8 1/4	5 1/2	2

DIMENSIONS (Inches) ...Fig. 2922

Sizes	A	B	C	D	E	F	G	H	J	K	O	P	R	S	T	U	V	W	X	Z
1/2	8 3/16	8 11/16	1 1/2	7/8	9/16	1/2	4	5/8	2 5/8	4 7/8	4 3/16	1/2	4	3/4	3 1/2	1 1/4	3 1/2	3 3/4	1 1/16	1 1/4
3/4	9 1/2	10 1/8	2 5/8	1	5/8	3/4	4	3/4	3 1/4	6 1/8	4 1/2	3/4	4	7/8	4 1/2	1 1/2	4	4 5/8	2	2
1	11 1/16	11 13/16	3 1/4	1 1/16	1 1/16	1	4	3/4	3 1/2	6 1/2	5 7/8	1	8	3/4	5	2 1/4	4 1/2	4 7/8	2 1/2	2
1 1/4	14 1/16	15 3/16	3 7/8	1 5/16	3/4	1 1/2	4	3/4	3 7/8	8 1/4	7 1/16	1 1/4	8	7/8	6 5/8	2 3/4	6	5 1/4	3	2
1 1/2	14 1/16	15 3/16	3 7/8	1 5/16	13/16	1 1/2	4	7/8	4 1/2	8 1/4	7 1/8	1 1/2	8	7/8	6 5/8	2 3/4	6	6 1/8	3	2
2	16 3/8	17 3/4	5	1 7/16	7/8	2	8	3/4	5	10	8 1/16	2	8	7/8	7 7/8	3 3/4	7	6 1/2	4	2
2 1/2	17 9/16	19 3/16	5 1/4	1 7/16	1	2 1/2	8	7/8	5 7/8	10	9	2 1/2	8	7/8	7 7/8	3 3/4	8	7 1/2	4 1/4	2
3	19 15/16	21 11/16	6 1/2	1 9/16	1 1/8	3	8	7/8	6 5/8	11	9 9/16	3	8	7/8	9 1/4	5 1/16	9	8 1/4	5 1/2	2

NOTE - Dimensions shown in Column "E" include 1/16" raised face.

WEIGHTS: On Application

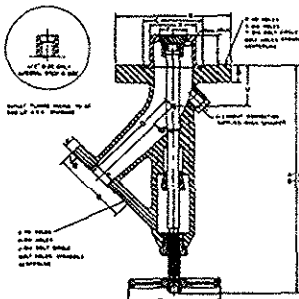

Fig. 2920

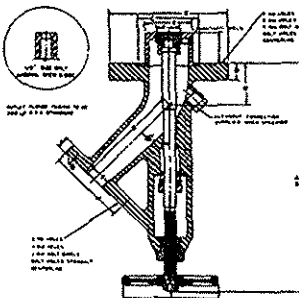

Fig. 2922

CORROSION RESISTANT FLUSH BOTTOM TANK VALVES

CLASS 600

PRESSURE/TEMPERATURE RATINGS
In accordance with ASME B16.34

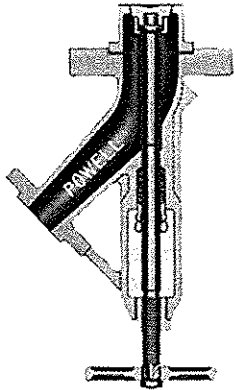

Fig. 2921
Disc opens into tank

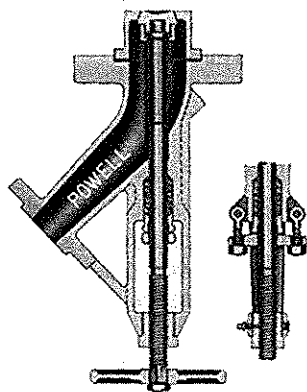

Fig. 2923
Disc opens into valve

SPECIFICATIONS

- Outlet flanges have dimensions conforming to ASME B16.5

FEATURES

- Powell Flush Bottom Tank Valves are designed for the convenient and fast draining of metal tanks (with or without steam jackets), wood, glass or vitreous-lined tanks and autoclaves. The outlet is placed at any angle approximately 45° to the centerline of the valve
- These valves are made in Stainless Steel, Nickel Alloys and Carbon Steel
- Valves are made with fullway area through valve body with minimum pressure drop

ORDERING

- These valves are available on special order
- Dimensions "X" and "Z" are Powell Standard for outside diameter and height of the seat sleeve and will be supplied unless otherwise ordered. When special dimensions are necessary, customer must specify
- Valve sizes are determined by outlet flange

DIMENSIONS (Inches) ...Fig. 2921

Sizes	A	B	C	D	E	F	G	H	J	K	O	P	R	S	T	U	V	W	X	Z
1/2	8 5/8	8 1/8	2 1/2	1	9/16	3/4	4	5/8	2 5/8	5 1/4	4 7/16	1/2	4	3/4	3 7/8	1 5/8	4	3 3/4	1 1/16	1 1/4
3/4	10 7/16	9 5/16	2 7/8	1 1/16	5/8	1	4	3/4	3 1/4	6 1/8	4 3/4	3/4	4	7/8	4 1/2	1 13/16	4 1/2	4 5/8	2	2
1	11 15/16	10 11/16	2 7/8	1 1/16	1 1/16	1 1/4	4	3/4	3 1/2	6 1/8	6 1/8	1	4	7/8	4 1/2	2 1/2	5	4 7/8	2 1/2	2
1 1/4	14 13/16	13 5/16	4 1/8	1 5/16	1 3/16	1 3/4	4	3/4	3 7/8	7 1/2	7 3/8	1 1/4	8	7/8	5 7/8	2 3/4	7	5 1/4	3	2
1 1/2	14 13/16	13 5/16	4 1/8	1 5/16	7/8	1 3/4	4	7/8	4 1/2	7 1/2	7 7/16	1 1/2	8	7/8	5 7/8	2 3/4	7	6 1/8	3	2
2	17 7/16	15 11/16	5	1 7/16	1	2 1/4	8	3/4	5	8 1/4	8 7/16	2	8	7/8	6 5/8	3 3/4	8	6 1/2	4	2
2 1/2	18 3/4	16 3/4	5 1/2	1 9/16	1 1/8	2 3/4	8	7/8	5 7/8	9	9 3/8	2 1/2	8	1	7 1/4	3 3/4	10	7 1/2	4 1/4	2
3	21 1/4	19 1/8	6 3/16	1 11/16	1 1/4	3 1/4	8	7/8	6 5/8	10 3/4	9 15/16	3	8	1	8 1/2	5 1/16	10	8 1/4	5 1/2	2

DIMENSIONS (Inches) ...Fig. 2923

Sizes	A	B	C	D	E	F	G	H	J	K	O	P	R	S	T	U	V	W	X	Z
1/2	8 9/16	9 1/16	2 1/2	1	9/16	1/2	4	5/8	2 5/8	5 1/4	4 7/16	1/2	4	3/4	3 7/8	1 5/8	4	3 3/4	1 1/16	1 1/4
3/4	9 13/16	10 7/16	2 7/8	1 1/16	5/8	3/4	4	3/4	3 1/4	6 1/8	4 3/4	3/4	4	7/8	4 1/2	1 13/16	4 1/2	4 5/8	2	2
1	11 5/16	12 1/16	2 7/8	1 1/16	1 1/16	1	4	3/4	3 1/2	6 1/8	6 1/8	1	4	7/8	4 1/2	2 1/2	5	4 7/8	2 1/2	2
1 1/4	14 1/16	15 3/16	4 1/8	1 5/16	1 3/16	1 1/2	4	3/4	3 7/8	7 1/2	7 3/8	1 1/4	8	7/8	5 7/8	2 3/4	7	5 1/4	3	2
1 1/2	14 1/16	15 3/16	4 1/8	1 5/16	7/8	1 1/2	4	7/8	4 1/2	7 1/2	7 7/16	1 1/2	8	7/8	5 7/8	2 3/4	7	6 1/8	3	2
2	16 3/8	17 3/4	5	1 7/16	1	2	8	3/4	5	8 1/4	8 7/16	2	8	7/8	6 5/8	3 3/4	8	6 1/2	4	2
2 1/2	17 9/16	19 3/16	5 1/2	1 9/16	1 1/8	2 1/2	8	7/8	5 7/8	9	9 3/8	2 1/2	8	1	7 1/4	3 3/4	10	7 1/2	4 1/4	2
3	19 15/16	21 11/16	6 3/16	1 11/16	1 1/4	3	8	7/8	6 5/8	10 3/4	9 15/16	3	8	1	8 1/2	5 1/16	10	8 1/4	5 1/2	2

NOTE - Dimensions shown in Column "E" do not include 1/4" raised face.

WEIGHTS: On Application

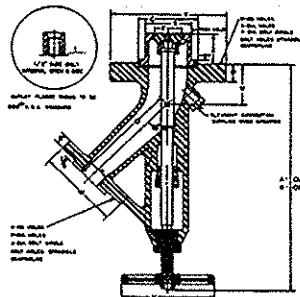

Fig. 2921

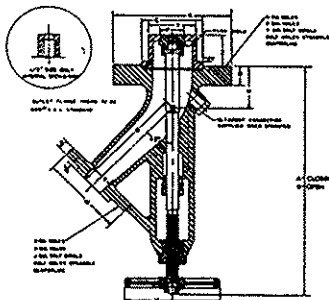

Fig. 2923

CRYOGENIC VALVES

BRONZE and STAINLESS STEEL

Dimensions for Non-Extended Valves are same as Standard Valve designs

GENERAL INDEX

	Page
General Information	106
Plus Factors	107-108
Standards and Specifications	138-167
Coding and Ordering Information	109
Standard "X" Dimensions	110
Installation Instructions	111
Venting and Stamping	112

Bronze Cryogenic Valves

GATE VALVES	
Class 150, 200 and 300	113-117
GLOBE and ANGLE VALVES	
Class 200 and 300	118-120
SWING CHECK VALVES	
Class 200	121
LIFT CHECK VALVES	
Class 200 and 300	122

Stainless Steel Cryogenic Valves

GATE VALVES	
Class 150, 200 and 300	123-125
Class 600	126
GLOBE VALVES	
Class 150, 200 and 300	127-129
Class 600	130
SWING CHECK VALVES	
Class 150, 200 and 300	131-132

Complete Tank Fill Assembly

8 Valve Assembly	133
----------------------------	-----

CRYOGENIC VALVES

BRONZE and STAINLESS STEEL

Gate · Globe · Angle · Swing Check and Lift Check Valves

QUALITY DESIGNED ... and built into the most complete line of valves in the industry, over 50 years experience in Cryogenic valve design and manufacture

- Cryogenic valves are offered in bronze or stainless steel for temperatures down to -423° F. Cryogenic valves are used in liquid service ... O₂, N₂, H₂, Methane, LNG as well as many other cold applications.
- Cryogenic valves are available with special trim, packing and gasket materials.
- Pipe Nipple Extensions are available for soft seat weld end valves.
- Non standard "X" Dimensions and other than standard valve ends are available on order.
- All seating surfaces and other critical dimensions are accurately machined for superior operation and long service life.
- All stems are one piece design for proper alignment and strength.
- A wide assortment of custom designs has been developed to accommodate specific and some times unique customer needs.
- Cryogenic valves are functioning in manual and automatic flow control, metering, block & bleed and isolation applications on stationary and mobile equipment.
- Gate and Globe valves can be supplied with Pneumatic, Electric or Hydraulic Operators with auxilliary equipment to satisfy almost any requirements.

ALL CRYOGENIC VALVES THOROUGHLY CLEANED, DEGREASED AND PIPE ENDS SEALED TO PREVENT CONTAMINATION

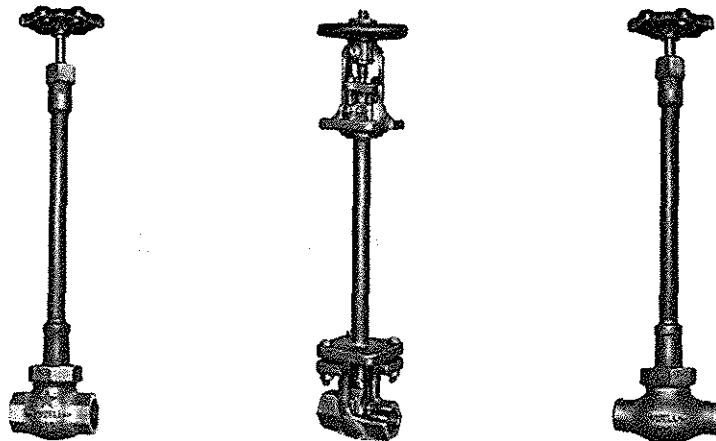

-Standardized for Quick Delivery -

Here are some of the Powell Plus Factors that give you extra value.

CLEANING

All extended and non-extended valves specified for oxygen or cryogenic service are specially processed and carefully cleaned in our own clean rooms. All parts are cleaned prior to assembly. The valves are assembled, tested, re-cleaned, packaged and sealed in accordance with approved shop procedures.

HANDWHEELS

All handwheels are constructed of malleable iron. Bronze valves 2 1/2" and larger are furnished with round rim design. Smaller sizes have non-heating and non-slip design. Bolted bonnet Stainless Steel valves are furnished with round rim design. Inside Screw Stainless Steel valves are furnished with non-heating and non-slip design.

GASKETS

Bonnet or cap gaskets where required are selected for oxygen compatibility and/or any special service required.

PACKING

All gate and globe valves are supplied with PTFE packing unless otherwise specified.

TRIM

Special trim materials are available to meet unique service requirements.

IDENTIFICATION

Gate and globe valves have an identification plate giving the figure number and valve material. This plate is either under the handwheel nut or fastened to the valve yoke. Additional tagging with unique numbering for installation purposes is also available.

NON-EXTENDED

Gate and globe valves are available in non-extended design. Parameters of these valves are as shown in this latest Wm. Powell Company catalog for standard valves.

VALVE ENDS

Non-standard pipe ends for most figure numbers are available on special order. A complete description or sketch of ends desired should be submitted for review. Pipe nipple extensions are recommended for soft seat welded end valves. Special butt weld end configurations per specifications are available on special order.

EXTENSIONS

Gate and globe valves with other than standard "X" extensions are available on special order. Mounting plates per required specifications can be supplied. Extension column parameters as specified on drawings may be altered if required to accommodate actuators. Welds are performed by qualified welders.

PLUS FACTORS - CONTINUED

SEATS

All seating surfaces are accurately machined to maintain alignment for the disc. Replacement of threaded-in seat rings is performed using standard parts and tools available from the Wm. Powell Company.

WEDGES

Gate valves have guided wedge and "T" head stem connection. Gate valves are available with soft inserts in the wedge for tightest possible shut-off. Most designs are available with split disc.

DISCS

Globe valves have self-centering disc design and are retained with a lock nut. Globe valves are available with soft insert in the disc as well as configurations for flow control.

STEMS

A one-piece stem design is used to assure positive alignment and strength. The portion of stem through the packing chamber is "superfinished" to assure packing sealing.

ACTUATORS

All extended and non-extended valves may be supplied with actuators as specified on special order. A complete description of requirements should be submitted for review.

SPECIALS

In addition to figure numbers described in this catalog, other designs are available. Standard figure numbers as shown in this latest Wm. Powell Company catalog can be modified for cryogenic service.

CRYOGENIC GATE · GLOBE · CHECK VALVES

Coding and Ordering Information

Figure Number Coding

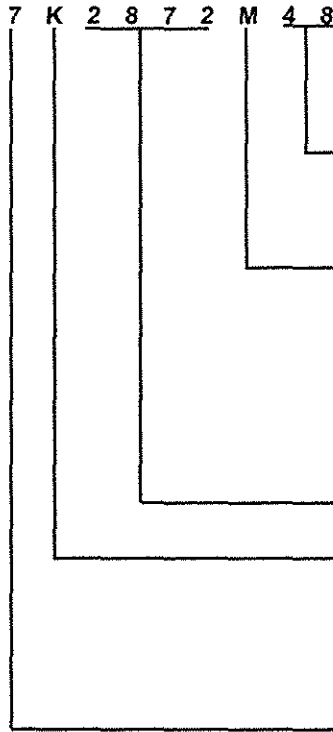

- "X" "X" Dimension expressed in 1/4" lengths' 1
- "XX" Unassigned digits (used on Check Valves)
- "NX" Non-Extended valve cleaned for Oxygen Service
- Options
 - "X" Valve with no options
 - "W" Weld end (Butt or Socket)
 - "P" SBP Ends
 - "M" Valve with mounting plate
 - "V" Vented Valve
 - "Z" Modified valves other than above
- Basic Figure Number
- Use four digits (0375, 2842, etc.)
- Disc/ seating material
 - "O" Standard disc
 - "K" PCTFE (Kel-F) disc insert
 - "T" PTFE disc insert
 - "G" Glass reinforced PTFE insert
 - "S" Stellite Hard Facing
- "7" Computer sorting code for Cryogenic Valves

Required Ordering Information

- A. Quantity
- B. Size
- C. Figure Number (see above for coding)
- D. Description
 - 1. Material grade of valve
 - 2. Special Options
 - a. Packing (PTFE is standard)
 - b. Gasket (Flexible Graphite is standard)
 - c. Flange finish
 - d. Operators
 - e. Trim Materials
 - f. Weld End matching pipe schedule
 - 3. Pressure and temperature of process (optional)

1. For a coded length over 99 use a letter and number Example: 25" = 100 = A0

POWELL STANDARD "X" DIMENSIONS CRYOGENIC GATE & GLOBE VALVES

Valve Size	INSIDE SCREW VALVES (1)				OUTSIDE SCREW & YOKE VALVES (2)			
	GATE		GLOBE		GATE		GLOBE	
	Inches	Valve Code	Inches	Valve Code	Inches	Valve Code	Inches	Valve Code
1/4"	13	52	12	48	13	52	12	48
3/8"	13	52	12	48	13	52	12	48
1/2"	13	52	12	48	13	52	12	48
3/4"	13	52	12	48	13	52	12	48
1"	14	56	13	52	14	56	13	52
1 1/4"	14	56	13	52	14	56	13	52
1 1/2"	14	56	13	52	14	56	13	52
2"	16	64	14	56	16	64	14	56
2 1/2"	18	72	16	64	19	76	14	56
3"	20	80	16	64	19	76	14	56
4"	20	80	18	72	20	80	16	64
6"					24	96	20	80
8"					28	B2	24	96
10"					32	C8	28	B2
12"					36	E4	28	C8
14"								
16"								
20"								

- (1) Centerline to top of packing sleeve
(2) Centerline to bottom of yoke

For a coded length over 99 use a letter and number Example: 25" = 100 =A0

EXTENDED BONNET VALVES

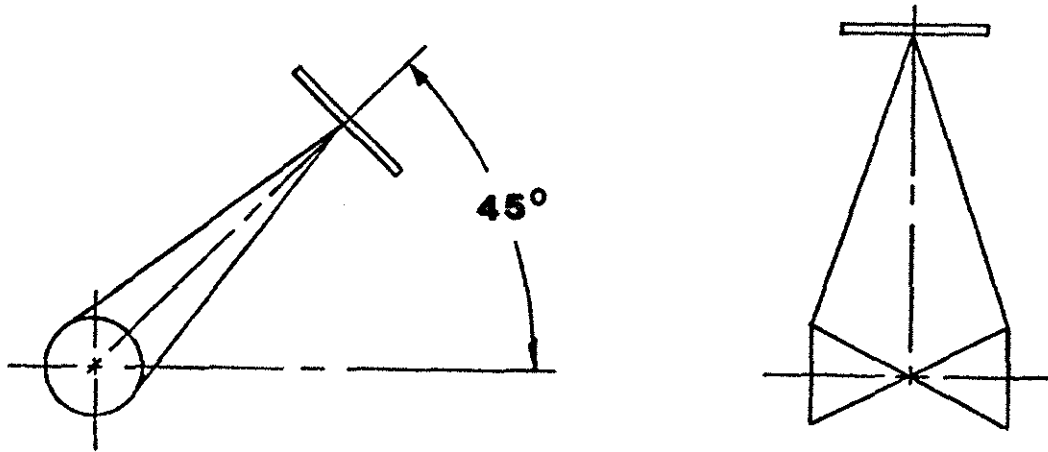

INSTALLATION INSTRUCTIONS

Extended bonnet valves are designed to provide an adequate bonnet length to maintain a steady state temperature at the packing, whether installed in cryogenic gaseous or liquid service.

When installed in cryogenic liquid service, special care must be given to stem orientation. Liquid should not be allowed to contact the packing. For this reason, the stem should be installed to achieve positive drainage to the body, creating a gas trap at the packing. It is recommended that valves be installed with stem in vertical (stem up) position. Satisfactory operation has been attained with stem inclined at 45° upward. In some cases, smaller valves have been found to function acceptably at lesser angles.

CONTINUOUS vs. INTERMITTENT SERVICE

Valves operating in cold service become covered with frost, and in continuous service at cryogenic temperatures, this frost becomes a ball of ice which can completely encapsulate the handwheel of ordinary valves rendering them inoperable. Extended bonnet valves are designed to prevent this ice ball from reaching the packing when properly installed (see installation instructions). Powell recommends that extended bonnet valves be selected for all continuous service applications below -50 F.

Intermittent service valves, such as sampling valves, used in the cold condition for only minutes at a time, may not require the extended bonnet design. However, Powell recommends that all valves operating below -50 F be of the extended bonnet type for flexibility in operating conditions and long-range safety.

VENTING and STAMPING GATE VALVES

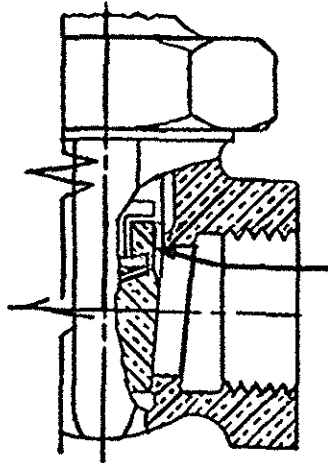

3/32" deep "V" groove radial cut on one face of disc. "V" groove is not practical when an insert is used in disc. Use 1/8" dia hole method

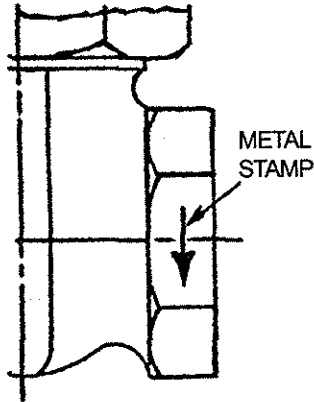

THREADED OR SOCKET WELD

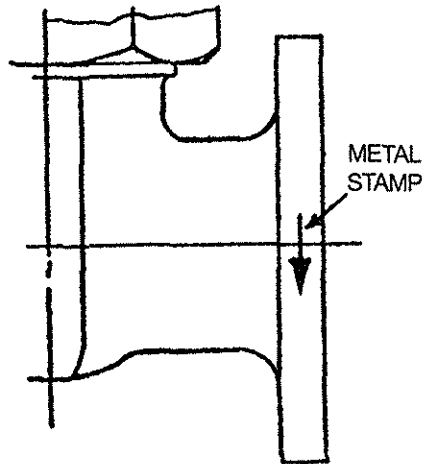

FLANGED

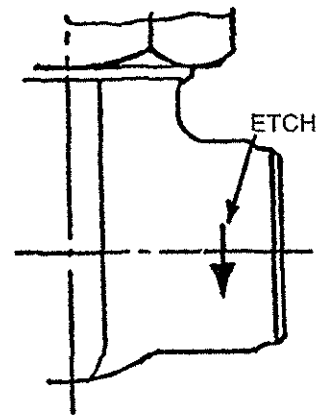

BUTT WELD OR SLIP JOINT ENDS

ARROW AS INDICATED ABOVE SHALL BE LOCATED ON VENTED END OF VALVE

Gate valves have the potential to trap cryogenic liquids in the bonnet cavity between the two sealing faces of the wedge. To prevent excessive pressure build-up due to vaporization of this liquid, consideration must be given to venting the bonnet chamber. The most common way is to cut a 3/32" "V" groove radially across the face of one side of the disc. **IT IS THE RESPONSIBILITY OF THE OWNER OR HIS PIPING DESIGNER TO DEFINE WHEN THIS VENT IS REQUIRED.**

A vertical arrow marking is placed on the vented end, as shown so as not to indicate flow direction.

CAUTION: Since the wedge on almost all gate valves may be reversed, care must be taken to be sure that the vented wedge is installed with the original orientation.

CRYOGENIC BRONZE GATE VALVES NON-EXTENDED

CLASS 150 UNION BONNET THREADED ENDS

PRESSURE/TEMPERATURE RATINGS
See Materials and Engineering Data Section

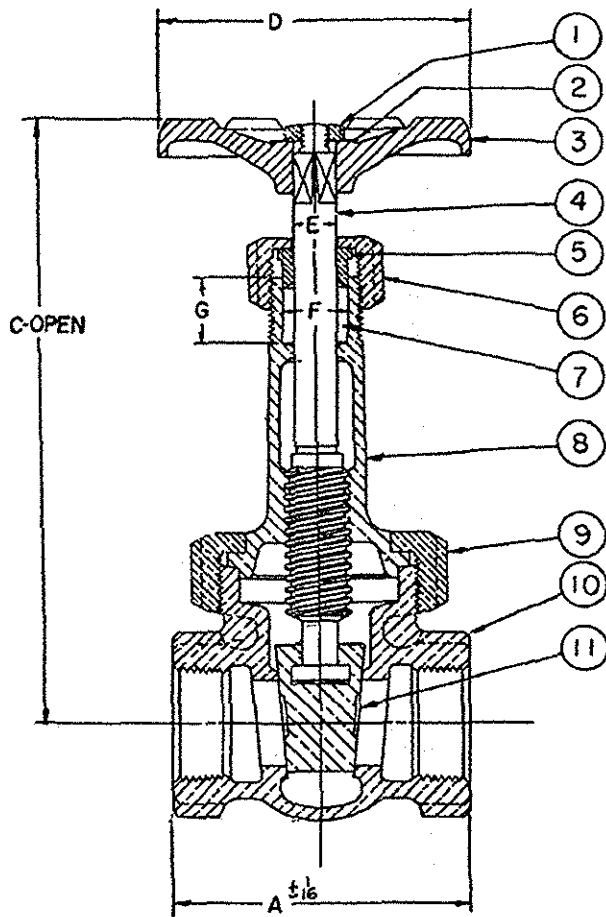

MATERIALS

DESCRIPTION	MATERIAL	ASTM Spec
1 WHEEL NUT	BRASS	B-16 ALLOY C36000
2 WHEEL PLATE	ALUMINUM	COMMERCIAL
3 HANDWHEEL	MAL. IRON	A-47, Grade 32510
4 STEM	SILICON BRONZE	B-371 ALLOY C69400
5 PACKING GLAND	BRASS	B-16 ALLOY C3600
6 PACKING NUT *	BRONZE	B-62 ALLOY C83600
7 PACKING	PTFE	COMMERCIAL
8 BONNET	BRONZE	B-62 ALLOY C83600
9 BONNET RING	BRONZE	B-62 ALLOY C83600
10 BODY	BRONZE	B-62 ALLOY C83600
11 DISC	BRONZE	B-62 ALLOY C83600

* Material-Brass ASTM B-16 Alloy C 3600 for 1/4" to 1" Valve sizes inclusive

SPECIFICATIONS

•MSS SP-80

FEATURES

•Valves cleaned for oxygen service and packaged to prevent contamination

DIMENSIONS (Inches)

SIZE	1/4	3/8	1/2	3/4	1	1 1/2	2	2 1/2	3
A END TO END	1 3/4	2	2 3/16	2 7/16	2 3/4	3 3/8	4	4 1/2	5
C CENTER TO TOP-OPEN	4 1/4	4 1/4	4 7/8	6 1/8	7 3/8	9 5/8	11 11/16	14 3/4	17 1/8
D DIA OF WHEEL	2 1/8	2 1/8	2 1/2	2 3/4	3	3 5/8	4 1/16	5 1/8	5 11/16
E DIA OF STEM	5/16	5/16	11/32	3/8	27/64	1/2	17/32	21/32	23/32
F DIA OF STUFFING BOX	17/32	17/32	9/16	9/16	11/16	13/16	7/8	1 1/8	1 1/4
G DEPTH OF STUFFING BOX	1/2	1/2	1/2	9/16	11/16	3/4	13/16	1	1 1/8

CLASS 150
Fig. 702714 T.E. XNX
Sizes, 1/4" through 3"

CRYOGENIC BRONZE GATE VALVES

CLASS 150-200 THREADED and FLANGED ENDS SOFT SEAT

PRESSURE/TEMPERATURE RATINGS

See Materials and Engineering Data Section

MATERIALS

DESCRIPTION	MATERIAL	ASTMSpec.
1 WHEEL NUT	BRASS	B-16
2 HANDWHEEL	MAL. IRON	A-47 GRADE 32510
3 STEM	STAINLESS STEEL	A-582 TYPE 303
4 PACKING GLAND	BRASS	ASTM B-16
5 PACKING NUT	BRONZE	ASTM B-62
6 PACKING	PTFE	COMMERCIAL
7 PACKING SLEEVE	SILICON BRONZE	B-371 ALLOY 694
8 EXTENSION COLUMN	STAINLESS STEEL	A-312 TYPE 304
9 BONNET	BRONZE	B-61
10 BONNET RING	BRONZE	B-61
11 BODY	BRONZE	B-61
12 DISC	BRONZE	ASTM B-61
13 RETAINING RING	STAINLESS STEEL	COMMERCIAL
14 RETAINING PLATE	SILICON BRONZE	ASTM B-371 ALLOY 694
15 DISC INSERT	PTFE	COMMERCIAL
16 STUD *	STAINLESS STEEL	A-193 GRADE B8
17 STUD NUT *	STAINLESS STEEL	A-194 GRADE 8
18 GASKET *	FLEXIBLE GRAPHITE	WPC
19 IDENT. PLATE	ALUMINUM	COMMERCIAL

*2 1/2" & 3" Size have Bolted Bonnet

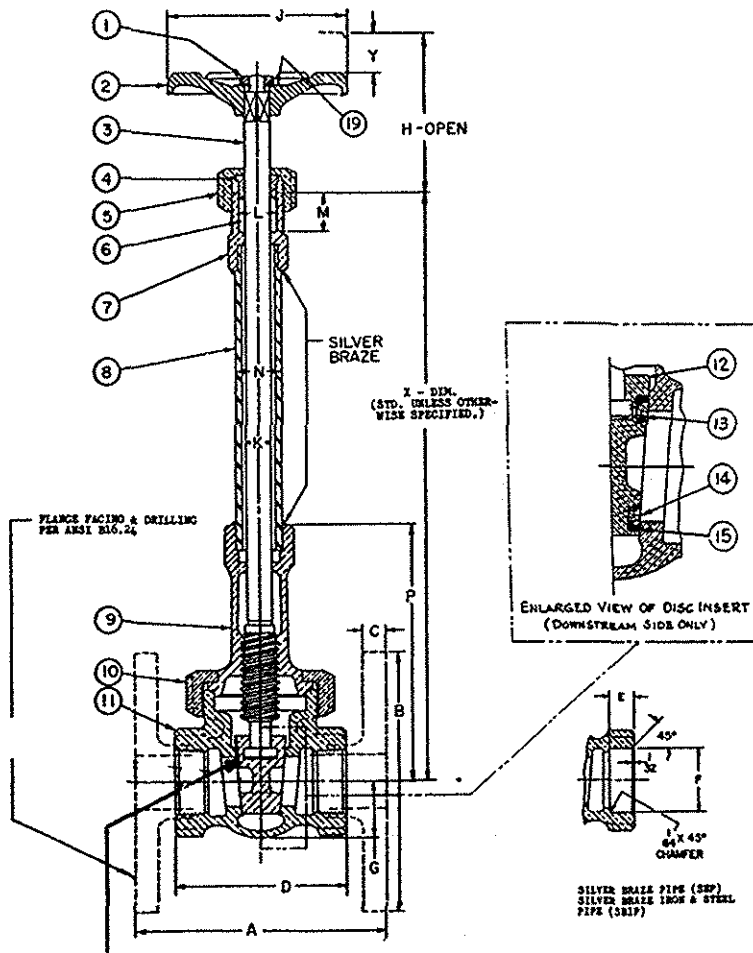

DISC TO BE VENTED WHEN SPECIFIED ON ORDER. A VERTICAL ARROW IS ETCHED ON VENTED END.

SPECIFICATIONS

•MSS-SP-80

FEATURES

- Valves Cleaned for use in oxygen service and packaged to prevent contamination
- Also available with Non Extended Stems

DIMENSIONS (Inches)

SIZE OF VALVE		2	2 1/2	3		
A	FACE TO FACE (F.E.)	5 1/2	6 1/2	7 1/4		
B	DIA. OF FLANGES	6	7	7 1/2		
C	THICKNESS OF FLANGES	1/2	9/16	5/8		
D	END TO END (T.E.) (S.B.P.) (S.B.I.P.)	4	4 5/8	5 1/8		
E	SOCKET DEPTH	21/32	25/32	53/64		
F	DIA OF SOCKET	(S.B.P.)	MAX	2.380	2.882	3.507
			MIN	2.375	2.875	3.500
		(S.B.I.P.)	+0.005 -0.000	2.351	2.846	3.465
G	CENTER TO BOTTOM	1 3/4	2 1/16	2 7/16		
H	PACKING SLEEVE TO TOP - OPEN	4 5/8	5 3/4	6 7/16		
J	DIA OF WHEEL	4 1/16	7	8		
K	DIA OF STEM	17/32	23/32	25/32		
L	DIA OF STUFFING BOX	7/8	1 1/4	1 3/8		
M	DEPTH OF STUFFING BOX	13/16	1 1/8	1 1/4		
N	DIA OF COLUMN	27/32	1	1 1/8		
P	CENTER TO TOP OF BONNET	7	9	10 15/16		
X	CENTER TO TOP OF STUFFING BOX (STD.)	16	18	20		
Y	LIFT	2 1/8	2 11/16	3 1/4		

Class 150
Fig. 7K0376 FE
Sizes: 2", 2 1/2", 3"

Class 200
Fig. 7K0375 TE, SBP, SBIP
Sizes: 2", 2 1/2", 3"

CRYOGENIC BRONZE GATE VALVES

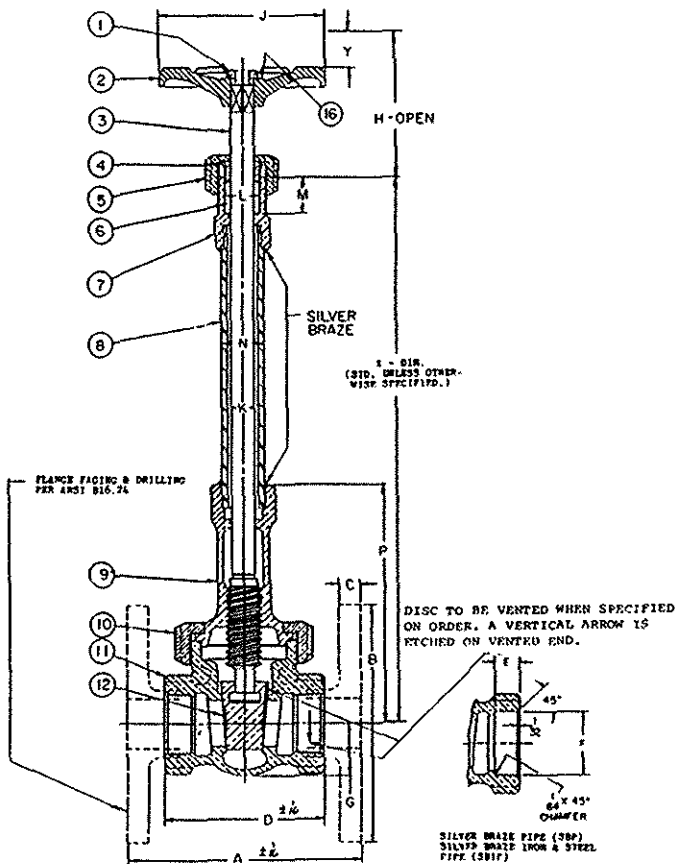

CLASS 150-200-300 THREADED and FLANGED ENDS

PRESSURE/TEMPERATURE RATINGS

See Materials and Engineering Data Section

MATERIALS

	DESCRIPTION	MATERIAL	ASTM Spec.
1	WHEEL NUT	BRASS	COMM
2	HANDWHEEL	MAL IRON	A-47 GR 32510
3	STEM	STAINLESS STEEL	A-582 TYPE 303
4	PACKING GLAND	BRASS	B-16
5	PACKING NUT	BRONZE/BRASS	B-62/B-16
6	PACKING	PTFE	COMMERCIAL
7	PACKING SLEEVE	SILICON BRONZE	B-371 C69400
8	EXTENSION COLUMN	STAINLESS STEEL	A-312 TYPE 304
9	BONNET	BRONZE	B-61
10	BONNET RING	BRONZE	B-61
11	BODY	BRONZE	B-61
12	DISC	BRONZE	B-61
13	STUD **	STAINLESS STEEL	A-193 GR B8
14	STUD NUT **	STAINLESS STEEL	A-194 GR 8
15	GASKET **	FLEXIBLE GRAPHITE	COMMERCIAL
16	IDENT PLATE	ALUMINUM	COMMERCIAL

**2 1/2" & 3" HAVE BOLTED BONNET

SPECIFICATIONS

•MSS-SP-80

FEATURES

- Valves Cleaned for oxygen service and packaged to prevent contamination
- Also available with Non Extended Stems

Class 150 Fig. 700376 FE
Sizes, 1" through 3"
Class 200 Fig. 700375 TE, SBP, SBIP
Sizes, 1/2" through 3"

DIMENSIONS (Inches)

SIZE OF VALVE		1/4	3/8	1/2	3/4	1	1 1/2	2	2 1/2	3		
A	FACE TO FACE (F.E.)					4 1/4	4 3/4	5 1/2	6 1/4	7 1/4		
B	DIA OF FLANGES					4 1/4	5	6	7	7 1/2		
C	THICKNESS OF FLANGES					3/8	7/16	1/2	9/16	5/8		
D	END TO END (T.E.) (S.B.P.) (S.B.I.P.)	113/16	2 1/16	2 5/16	2 9/16	2 15/16	3 1/2	4 5/8	4 5/8	5 1/8		
E	SOCKET DEPTH		17/64	5/16	3/8	13/32	7/16	21/32	25/32	53/64		
F	DIA OF SOCKET	S.B.P.	MAX	543	678	843	1,053	1,318	1,905	2,380	2,882	3,507
			MIN	540	675	840	1,050	1,315	1,900	2,375	2,875	3,500
		(S.B.I.P.)	+0.005	509	644	809	1,019	1,284	1,869	2,351	2,846	3,465
	(S.B.I.P.)	-0.000										
G	CENTER TO BOTTOM	5/8	5/8	3/4	7/8	1	1 3/8	1 3/4	2 1/16	2 7/16		
H	PACKING SLEEVE TO TOP-OPEN	2	2	2 2/16	2 9/16	3 1/8	3 15/16	4 5/8	5 3/4	6 7/16		
J	DIA OF WHEEL	2 1/8	2 1/8	2 1/2	2 3/4	3	3 5/8	4 1/16	7	8		
K	DIA OF STEM	5/16	5/16	11/32	3/8	27/64	1/2	17/32	23/32	25/32		
L	DIA OF STUFFING BOX	17/32	17/32	9/16	9/16	11/16	13/16	7/8	1 1/4	1 3/8		
M	DEPTH OF STUFFING BOX	1/2	1/2	9/16	9/16	11/16	1/2	13/16	1 1/8	1 1/4		
N	DIA OF COLUMN	9/16	9/16	11/16	11/16	27/32	27/32	27/32	1	1 1/8		
P	CENTER TO TOP OF BONNET	2 5/8	2 5/8		3 7/8	4	6 1/8	7	9	10 15/16		
X	CENTER TO TOP OF STUFFING BOX (STD)	13	13	13	13	14	14	16	18	20		
Y	LIFT	7/16	7/16	1/2	7/8	1 1/16	1 3/16	2 1/8	2 11/16	3 1/4		

Class 300
Fig. 700377 TE, SBP, SBIP
Sizes, 1/2" through 3"
Fig. 700378 FE Sizes, 1" through 3"

DIMENSIONS (Inches)

SIZE OF VALVE		1/4	3/8	1/2	3/4	1	1 1/2	2	2 1/2	3		
A	FACE TO FACE (F.E.)						4 15/16	5 1/4	7 3/4	8 1/2	8 13/16	
B	DIA OF FLANGES						4 7/8	6 1/8	6 1/2	7 3/4	8 1/4	
C	THICKNESS OF FLANGES						19/32	11/16	3/4	13/16	29/32	
D	END TO END (T.E.) (S.B.P.) (S.B.I.P.)	115/16	2 1/8	2 7/16	2 11/16	3	3 3/4	4 3/8	5	5 5/8		
E	SOCKET DEPTH		17/64	5/16	3/8	13/32	7/16	5/8	21/32	25/32	53/64	
F	DIA OF SOCKET	S.B.P.	MAX	543	678	843	1,053	1,318	1,905	2,380	2,882	3,507
			MIN	540	675	840	1,050	1,315	1,900	2,375	2,875	3,500
		(S.B.I.P.)	+0.005	509	644	809	1,019	1,284	1,869	2,351	2,846	3,465
	(S.B.I.P.)	-0.000										
G	CENTER TO BOTTOM	5/8	5/8	3/4	7/8	1 1/16	1 7/16	1 13/16	2 1/8	2 9/16		
H	PACKING SLEEVE TO TOP-OPEN	2 3/16	2 3/16	2 1/2	2 31/32	3 3/8	4 1/4	4 31/32	5 29/32	6 9/16		
J	DIA OF WHEEL	2 3/4	2 3/4	3	3 1/2	3 5/8	4 3/4	5 1/8	8	9		
K	DIA OF STEM	3/8	3/8	27/64	15/32	17/32	21/32	23/32	25/32	25/32		
L	DIA OF STUFFING BOX	9/16	9/16	11/16	13/16	7/8	1 1/8	1 1/4	1 3/8	1 3/8		
M	DEPTH OF STUFFING BOX	9/16	9/16	11/16	1/2	13/16	1	1 1/8	1 1/4	1 1/4		
N	DIA OF COLUMN	11/16	11/16	27/32	27/32	27/32	1 1/16	1 5/16	1 7/8	1 7/8		
P	CENTER TO TOP OF BONNET	2 7/8	2 7/8	3 9/16	4 13/32	5 1/8	6 15/16	8 17/32	9 3/16	10 13/16		
X	CENTER TO TOP OF STUFFING BOX (STD)	13	13	13	13	14	14	16	18	20		
Y	LIFT	7/16	7/16	1/2	7/8	1 1/16	1 9/16	2 1/8	2 11/16	3 1/4		

CRYOGENIC BRONZE GATE VALVES

CLASS 150 BOLTED FLANGED YOKE-BONNET

PRESSURE/TEMPERATURE RATINGS

See Materials and Engineering Data Section

MATERIALS

DESCRIPTION	MATERIAL	ASTM Spec.
1 BUSHING	SILICON BRONZE	B 371 C69400
2 LOCKNUT	SILICON BRONZE	B 371 C69400
4 HANDWHEEL	MAL. IRON	A 47 GRADE 32510
5 HANDWHEEL KEY	STEEL	COMMERCIAL
6 BUSHING RETAINER	SILICON BRONZE	B 371 C69400
7 SET SCREW	STEEL	COMMERCIAL
8 YOKEARM	BRONZE	B 62
9 EXTENSION COLUMN	STAINLESS STEEL	A 312 TYPE 304
10 BONNET	BRONZE	B 62
11 STEM	STAINLESS STEEL	A 582 TYPE 303
12 GLAND EYEBOLT NUT	STAINLESS STEEL	300 SERIES
13 GLAND EYEBOLT	STAINLESS STEEL	300 SERIES
14 GLAND EYEBOLT PIN	STAINLESS STEEL	300 SERIES
15 GLAND FLANGE	STAINLESS STEEL	A 182 GRADE F 304
16 GLAND	SILICON BRONZE	B 371 C69400
17 PACKING	PTFE	COMMERCIAL
18 PACKING COLLAR	SILICON BRONZE	B 371 C69400
19 YOKE BOLT	STAINLESS STEEL	A 193 GRADE B8
20 YOKE BOLT NUT	STAINLESS STEEL	A 194 GRADE 8
21 GASKET	FLEXIBLE GRAPHITE	COMMERCIAL
22 BODY	BRONZE	B 62
23 WEDGE	BRONZE	B 62
24 IDENT. PLATE	ALUMINUM	COMMERCIAL

8" Size has Separable Yoke Arm

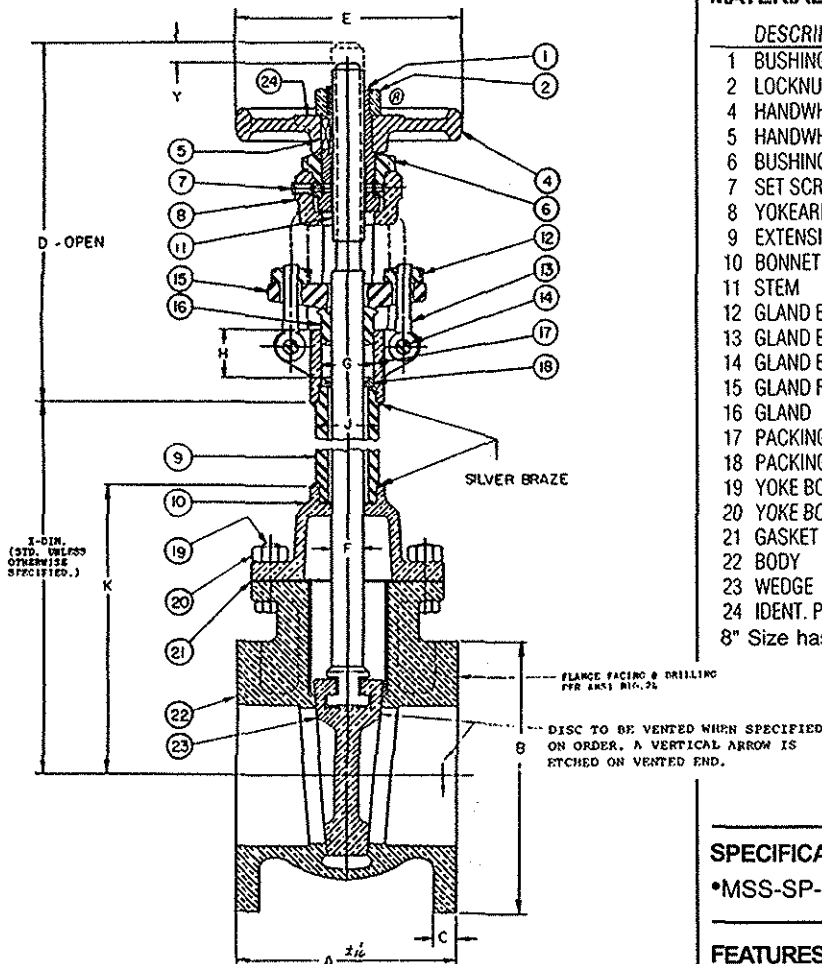

SPECIFICATIONS

•MSS-SP-80

FEATURES

•Valves Cleaned for oxygen service and packaged to prevent contamination.

DIMENSIONS (Inches)

Size		2 ½	3	4	6	8
A	FACE TO FACE (F.E.)	7 ½	8	9	10 ½	11 ½
B	DIAMETER OF FLANGES	7	7 ½	9	11	13 ½
C	THICKNESS OF FLANGES	9/16	5/8	11/16	13/16	15/16
D	PACKING SLEEVE TO TOP - OPEN	10 3/16	11 ½	15	21 5/8	25 1/8
E	DIAMETER OF HANDWHEEL	6	8	9	12	14
F	DIAMETER OF STEM	11/16	¾	15/16	1 1/8	
G	DIAMETER OF STUFFING BOX	1 1/8	1 ¼	1 ½	1 ¾	
H	DEPTH OF STUFFING BOX	1 5/16	1 7/32	1 9/16	2 ½	
J	DIAMETER OF COLUMN	1 5/16	1 5/16	1 21/32	1 29/32	1 3/4
K	CENTER TO TOP OF BONNET	5 7/16	6 ¼	8 ½	12 1/8	
X	CENTER TO BOTTOM OF YOKE	19	19	20	24	28
Y	LIFT	2 11/16	3 7/32	4 3/8	6 13/32	

Fig. 701414 FE
Sizes, 2" through 8"

CRYOGENIC BRONZE GATE VALVES

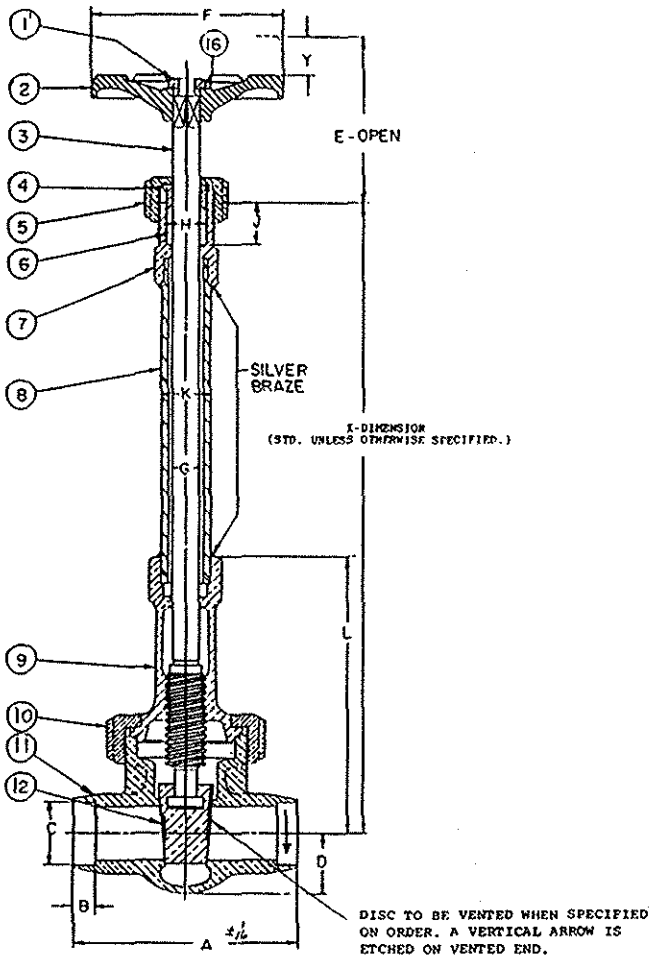

CLASS 200 UNION BONNET SILVER BRAZE TUBING ENDS

PRESSURE/TEMPERATURE RATINGS

See Materials and Engineering Data Section

MATERIALS

DESCRIPTION	MATERIAL	ASTM Spec.
1 WHEEL NUT	BRASS	COMMERCIAL
2 HANDWHEEL	MAL. IRON	A-47 GR 32510
3 STEM	STAINLESS STEEL	A-582 TYPE 303
4 PACKING GLAND	BRASS	B-16
5 PACKING NUT	BRONZE/BRASS	B-62/B-16
6 PACKING	PTFE	COMMERCIAL
7 PACKING SLEEVE	SILICON BRONZE	B-371 C69400
8 EXTENSION COLUMN	STAINLESS STEEL	A-312 TYPE 304
9 BONNET	BRONZE	B-61
10 BONNET RING	BRONZE	B-61
11 BODY	BRONZE	B-61
12 DISC	BRONZE	B-61
13 STUD **	STAINLESS STEEL	A-193 GR B8
14 STUD NUT **	STAINLESS STEEL	A-193 GR 8
15 GASKET	FLEXIBLE GRAPHITE	COMMERCIAL
16 IDENT PLATE	ALUMINUM	COMMERCIAL

**2 1/2" & 3" BOLTED BONNET

SPECIFICATIONS

•MSS-SP-80

FEATURES

- Valves Cleaned for oxygen service and packaged to prevent contamination
- Also available with Non Extended Stems

DIMENSIONS (Inches)

Fig. 702842 SBT
Sizes, 1/2" through 3"

SIZE		1/4	3/8	1/2	3/4	1	1 1/2	2	2 1/2	3
A	END TO END (S.B.T.)	1 3/4	2 1/4	2 1/2	3	3 1/4	4	4 1/2	5 1/4	6
B	DEPTH OF SOCKET (S.B.T.)	17/64	5/16	3/16	13/32	7/16	5/8	21/32	25/32	53/64
C	DIA. OF SOCKET	MAX.	.381	.506	.631	.881	1.132	1.633	2.133	3.133
		MIN.	.377	.502	.627	.877	1.128	1.628	2.128	3.128
D	CENTER TO BOTTOM	5/8	5/8	3/4	7/8	1	1 3/8	1 3/4	2 1/16	2 7/16
E	PACKING SLEEVE TO TOP-OPEN	2	2	2 3/16	2 9/16	3 1/8	3 15/16	4 5/8	5 3/4	6 7/16
F	DIA. OF WHEEL	2 1/8	2 1/8	2 1/2	2 3/4	3	3 5/8	4 1/16	7	8
G	DIA. OF STEM	5/16	5/16	11/32	3/8	27/64	1/2	17/32	23/32	25/32
H	DIA. OF STUFFING BOX	17/32	17/32	9/16	9/16	11/16	13/16	7/8	1 1/4	1 3/8
J	DEPTH OF STUFFING BOX	1/2	1/2	9/16	9/16	11/16	3/4	13/16	1 1/8	1 1/4
K	DEPTH OF COLUMN	9/16	9/16	11/16	11/16	27/32	27/32	27/32	1	1 1/8
L	CENTER TO TOP OF BONNET	2 5/8	2 5/8	3	3 7/8	4 5/8	6 1/8	7 9/16	9 1/4	10 15/16
X	CENTER TO TOP OF STUFFING BOX (STD)	13	13	13	13	14	14	16	18	20
Y	LIFT	7/16	7/16	1/2	7/8	1 1/16	1 9/16	2 1/8	2 11/16	3 1/4

CRYOGENIC BRONZE GLOBE VALVES

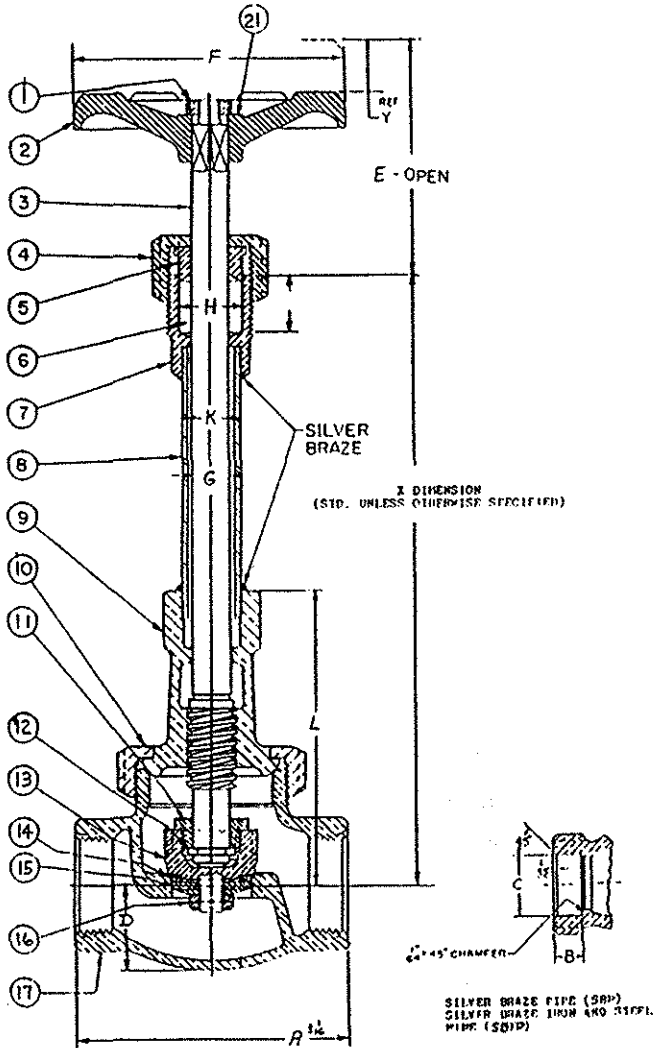

CLASS 200 UNION BONNET

PRESSURE/TEMPERATURE RATINGS

See Materials and Engineering Data Section

MATERIALS (Soft Seat Valves)

DESCRIPTION	MATERIAL	ASTM Spec.
1 WHEEL NUT	BRASS	B-16
2 HANDWHEEL	MAL. IRON	A-47 GRADE 32510
3 STEM	STAINLESS STEEL	A-582 TYPE 303
4 PACKING NUT	BRONZE/BRASS	ASTM B-62/B-16
5 PACKING GLAND	BRASS	ASTM B-16
6 PACKING	PTFE	COMMERCIAL
7 PACKING SLEEVE	SILICON BRONZE	B-371 ALLOY 69400
8 EXTENSION COLUMN	STAINLESS STEEL	A-312 TYPE 304
9 BONNET	BRONZE	B-61
10 BONNET RING	BRONZE	B-61
11 DISC LOCKNUT	SILICON BRONZE	B-371 C69400
12 HORSE SHOE RING	STAINLESS STEEL	300 SERIES
13 DISC HOLDER	SILICON BRONZE	B-371 C69400
14 DISC INSERT	PCTFE	COMMERCIAL
15 DISC PLATE	BRASS	B-16
16 DISC NUT	SILICON BRONZE	B-371 C69400
17 BODY	BRONZE	B-61
18 STUD *	STAINLESS STEEL	A-193 GRADE B8
19 STUD NUT *	STAINLESS STEEL	A-194 GRADE 8
20 GASKET *	FLEXIBLE GRAPHITE	COMMERCIAL
21 IDENT. PLATE	ALUMINUM	COMMERCIAL
13A DISC	(METALLIC DISC VALVES) SILICON BRONZE	B-371 C69400

*2 1/2" & 3" BOLTED BONNET

SPECIFICATIONS

*MSS-SP-80

FEATURES

- Valves Cleaned for oxygen service and packaged to prevent contamination
- Also available with Non Extended Stems

DIMENSIONS (Inches)

SIZE		1/4	3/8	1/2	3/4	1	1 1/2	2	2 1/2	3
A	END TO END (TE)(SBP)(SBIP)	2 1/8	2 1/4	2 1/2	3	3 9/16	4 5/8	5 3/4	6 5/8	8 1/2
B	SOCKET DEPTH + 1/64 - 0	17/64	5/16	3/8	13/32	7/16	5/8	21/32	25/32	53/64
C	DIA. OF SOCKET (S.B.P.)	MAX.	.543	.678	.843	1.053	1.318	1.905	2.862	3.507
		MIN.	.540	.675	.840	1.050	1.315	1.900	2.875	3.500
		(S.B.I.P.) +.005-000	.509	.644	.809	1.019	1.284	1.869	2.351	2.846
D	CENTER TO BOTTOM	9/16	9/16	3/4	15/16	1 1/8	1 1/2	1 7/8	2 5/16	2 3/4
E	PACKING SLEEVE TO TOP-OPEN	1 13/16	1 13/16	2 1/8	2 7/16	2 11/16	3 3/16	3 7/16	4 1/16	4 3/4
F	DIA. OF WHEEL	2 1/2	2 1/2	2 3/4	3 1/4	3 5/8	4 3/4	5 11/16	7	8
G	DIA. OF STEM	5/16	5/16	3/8	27/64	1/2	35/64	11/16	23/32	25/32
H	DIA. OF STUFFING BOX	17/32	17/32	9/16	11/16	13/16	1 1/16	1 1/8	1 1/4	1 3/8
J	DEPTH OF STUFFING BOX	1/2	1/2	9/16	11/16	3/4	15/16	1	1 1/8	1 1/4
K	DIA. OF COLUMN	9/16	9/16	11/16	27/32	27/32	1 1/16	1 1/16	1 1/16	1 5/16
L	CENTER TO TOP OF BONNET	2 9/16	2 9/16	2 15/16	3 3/8	3 3/4	4 13/16	5 1/2	6 7/16	7 3/8
X	CENTER TO TOP OF STUFFING BOX	12	12	12	12	13	13	14	16	16
Y	LIFT	21/64	21/64	7/16	7/16	17/32	25/32	1 1/32	1 1/8	1 1/4

(Soft Seat Valves)
Fig. 7K0110 TE, SBP, SBIP
Sizes, 1/4" through 3"

(Metallic Disc Valves)
Fig. 700110TE, SBP, SBIP
Sizes, 1/4" through 3"

CRYOGENIC BRONZE GLOBE VALVES

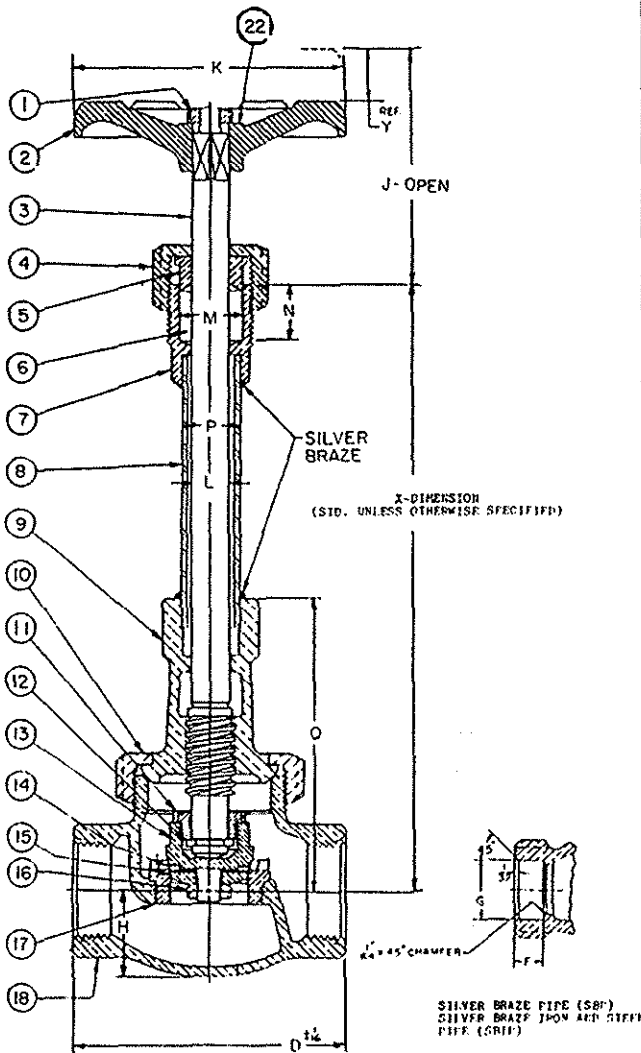

CLASS 200 and 300 UNION BONNET RENEWABLE SEAT and DISC

PRESSURE/TEMPERATURE RATINGS
See Materials and Engineering Data Section

MATERIALS (Soft Seat Valves)

DESCRIPTION	MATERIAL	ASTM Spec.
1 WHEEL NUT	BRASS	COMMERCIAL
2 HANDWHEEL	MAL. IRON	A-47 GRADE 32510
3 STEM	STAINLESS STEEL	A-582 TYPE 303
4 PACKING NUT	BRONZE/BRASS	ASTM B-62
5 PACKING GLAND	BRASS	ASTM B-16
6 PACKING	PTFE	COMMERCIAL
7 PACKING SLEEVE	SILICON BRONZE	B-371 C69400
8 EXTENSION COLUMN	STAINLESS STEEL	A-312 TYPE 304
9 BONNET	BRONZE	B-61
10 BONNET RING	BRONZE	B-61
11 DISC LOCKNUT	SILICON BRONZE	B-371 C69400
12 HORSE SHOE RING	STAINLESS STEEL	300 SERIES
13 DISC HOLDER*	SILICON BRONZE	B-371 C69400
14 DISC INSERT	PCTFE	COMMERCIAL
15 DISC PLATE	BRASS B-16	
16 DISC NUT	SILICON BRONZE	B-371 C69400
17 SEAT RING*	SILICON BRONZE	B-371 C69400
18 BODY	BRONZE	B-61
19 STUD**	STAINLESS STEEL	A-193 GRADE B8
20 STUD NUT**	STAINLESS STEEL	A-194 GRADE 8
21 GASKET*	FLEXIBLE GRAPHITE	COMMERCIAL
22 IDENT. PLATE	ALUMINUM	COMMERCIAL
(METALLIC DISC VALVES)		
14A DISC.	SILICON BRONZE	B-371 C69400

* 2 1/2" & 3" - ASTM B61

** 2 1/2" & 3" Bolted Bonnet

SPECIFICATIONS

•MSS-SP-80

Class 200

(Soft Seat Valves)
Fig. 7K0102TE, SBP, SBIP
Sizes, 1/4" through 3"

(Metallic Disc Valves)
Fig. 700102TE, SBP, SBIP
Sizes, 1/4" through 3"

Class 300

(Soft Seat Valves)
Fig. 7K1202, TE, SBP, SBIP
Sizes 1/4" through 3"

(Metallic Disc Valves)
Fig. 701202, TE, SBP, SBIP
Sizes, 1/4" through 3"

DIMENSIONS (Inches)

SIZE	1/4	3/8	1/2	3/4	1	1 1/2	2	2 1/2	3	
D END TO END (TE) (SBP) (SBIP)	2 1/8	2 1/4	2 1/2	3	3 9/16	4 5/8	5 3/4	6 5/8	8 1/2	
F SOCKET DEPTH + 1/64 - 0	17/64	5/16	3/8	13/32	7/16	5/8	21/32	25/32	53/64	
G DIA. OF SOCKET	(S.B.P.) MAX	543	678	843	1,053	1,318	1,905	2,380	2,862	3,507
	(S.B.P.) MIN	540	675	840	1,050	1,315	1,900	2,375	2,875	3,500
	(S.B.I.P.) +.005 - .000	509	644	809	1,019	1,284	1,869	2,351	2,846	3,465
H CENTER TO BOTTOM	9/16	9/16	3/4	15/16	1 1/8	1 1/2	1 7/8	2 5/16	2 3/4	
J PACKING SLEEVE TO TOP-OPEN	1 13/16	1 13/16	2 1/8	2 7/16	2 11/16	3 3/16	3 7/16	4 1/16	4 3/8	
K DIA. OF WHEEL	2 1/2	2 1/2	2 3/4	3 1/4	3 5/8	4 3/4	5 11/16	6	7	
L DIA. OF STEM	5/16	5/16	3/8	27/64	1/2	39/64	11/32	23/32	25/32	
M DIA. OF STUFFING BOX	17/32	17/32	9/16	11/16	13/16	1 1/16	1 1/8	1 1/4	1 3/8	
N DEPTH OF STUFFING BOX	1/2	1/2	9/16	11/16	1 1/4	1 5/16	1 1/2	1 1/8	1 1/4	
P DIA. OF COLUMN	9/16	9/16	11/16	27/32	27/32	1 1/16	1 1/16	1 1/16	1 5/16	
Q CENTER TO TOP OF BONNET	2 9/16	2 9/16	2 15/16	3 3/8	3 3/4	4 13/16	5 1/2	6 7/16	7 3/8	
X CENTER TO TOP OF STUFFING BOX	12	12	12	12	13	13	14	16	16	
Y LIFT	1/4	1/4	5/16	5/16	7/16	9/16	13/16	1 1/8	1 5/16	

Also available with Silver Braze Tubing Ends, Fig. 7K2872 & 702872

DIMENSIONS (Inches)

SIZE	1/4	3/8	1/2	3/4	1	1 1/2	2	2 1/2	3	
D END TO END (TE) (SBP) (SBIP)	2 1/4	2 3/8	2 5/8	3 1/4	3 13/16	4 7/8	6	7 1/2	8 3/4	
F SOCKET DEPTH + 1/64 - 0	17/64	5/16	3/8	13/32	7/16	5/8	21/32	25/32	53/64	
G DIA. OF SOCKET	(S.T.B.P.) MAX	543	678	843	1,053	1,318	1,905	2,380	2,862	3,507
	(S.T.B.P.) MIN	540	675	840	1,050	1,315	1,900	2,375	2,875	3,500
	(S.B.I.P.) +.005 - .000	509	644	809	1,019	1,284	1,869	2,351	2,846	3,465
H CENTER TO BOTTOM	19/32	19/32	25/32	1	1 1/32	1 19/32	1 31/32	2 1/2	2 7/8	
J PACKING SLEEVE TO TOP-OPEN	2 3/32	2 11/32	2 19/32	2 27/32	3 1/32	3 1/2	3 27/32	4 5/32	4 11/32	
K DIA. OF WHEEL	2 1/2	2 1/2	2 3/4	3 1/4	3 5/8	4 1/2	5 11/16	6	7	
L DIA. OF STEM	11/32	3/8	27/64	15/32	17/32	27/32	23/32	25/32	31/32	
M DIA. OF STUFFING BOX	17/32	17/32	9/16	11/16	15/16	1 1/16	1 1/8	1 1/4	1 3/8	
N DEPTH OF STUFFING BOX	1/2	1/2	9/16	11/16	1 1/4	1 5/16	1 1/2	1 1/8	1 1/4	
P DIA. OF COLUMN	9/16	9/16	11/16	27/32	27/32	1 1/16	1 1/16	1 1/16	1 5/16	
Q CENTER TO TOP OF BONNET	2 9/16	2 9/16	2 15/16	3 3/8	3 3/4	4 13/16	5 1/2	6 7/16	7 3/8	
X CENTER TO TOP OF STUFFING BOX	12	12	12	12	13	13	14	16	16	
Y LIFT	1/4	1/4	5/16	5/16	7/16	9/16	13/16	1 1/8	1 5/16	

CRYOGENIC BRONZE GLOBE and ANGLE VALVES

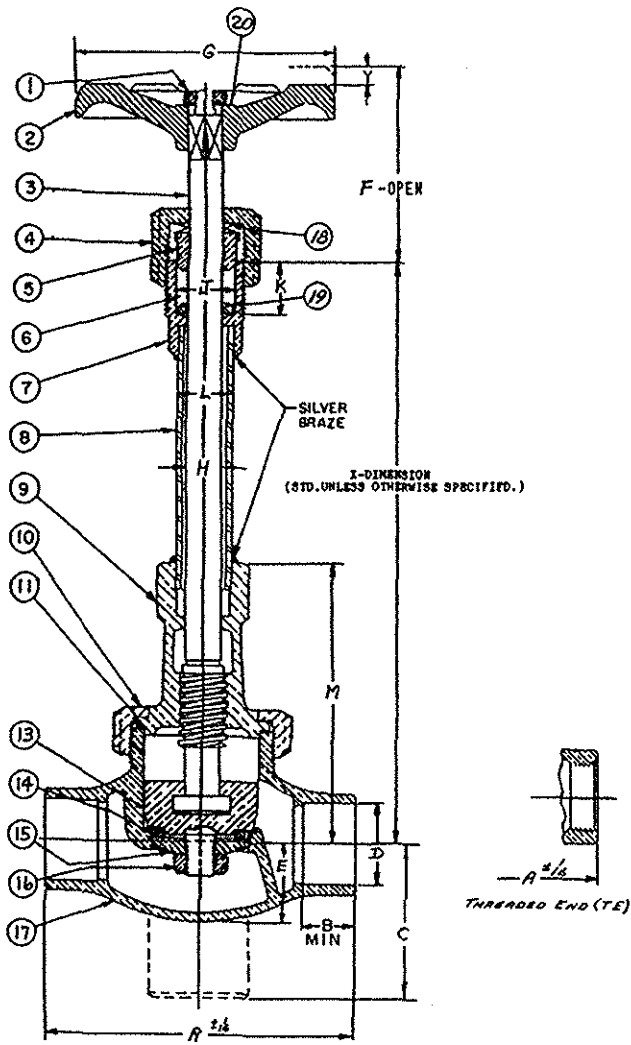

Fig. 7K0174 TE Globe
Fig. 7K2874 SBT Globe
Sizes, 1/4" through 2"

Fig. 7K2875 SBT Angle
Sizes 1 1/2"

CLASS 300 UNION BONNET

PRESSURE/TEMPERATURE RATINGS
See Materials and Engineering Data Section

MATERIALS (Soft Seat Valves)

DESCRIPTION	MATERIAL	ASTM Spec.
1 WHEEL NUT	BRASS	COMMERCIAL
2 HANDWHEEL	MAL. IRON	A-47 OR 32510
3 STEM	STAINLESS STEEL	A-562 TYPE 303
4 PACKING NUT	BRASS	B-16
5 PACKING GLAND	BRASS	B-16
6 PACKING	PTFE	COMMERCIAL
7 PACKING SLEEVE	SILICON BRONZE	B-371 C69400
8 EXTENSION COLUMN	STAINLESS STEEL	A-312 TYPE 304
9 BONNET	BRONZE	B-61
10 BONNET RING	BRONZE	B-61
11 GASKET	PTFE	COMMERCIAL
13 DISC HOLDER	SILICON BRONZE	B-371 C69400
14 DISC INSERT	PCTFE	COMMERCIAL
15 DISC PLATE	BRASS	B-16
16 DISC NUT	SILICON BRONZE	B-371 C69400
17 BODY	BRONZE	B-61
18 SPRING WASHER	STAINLESS STEEL	COMMERCIAL
19 COLLAR	BRASS	B-16
20 IDENT PLATE	ALUMINUM	COMMERCIAL

SPECIFICATION

- MSS SP-80

FEATURES

- Valves Cleaned for oxygen service and packaged to prevent contamination.
- Also available with Non Extended Stems

DIMENSIONS (Inches)

SIZE OF VALVE		1/4	3/8	1/2	3/4	1	1 1/2	2
A	END TO END (GLOBE) (T.E.)	2 1/8	2 1/4	2 1/2	3	3 9/16	4 5/8	5 3/4
	(SBT)	2 1/2	3	3 1/4	3 3/4	4 1/4	5 1/4	6 1/2
B	DEPTH OF SOCKET (SBT)	17/64	5/16	3/8	13/32	7/16	5/8	27/32
C	CENTER TO END (ANGLE) (SBT)						2 15/16	
D	DIA. OF SOCKET	MAX.	.381	.506	.631	.881	1.132	1.635
		MIN.	.377	.502	.627	.877	1.128	1.627
E	CENTER TO BOTTOM	19/32	19/32	13/16	1	1 3/16	1 9/16	2
F	PACKING SLEEVE TO TOP-OPEN	2	2	2 9/32	2 11/16	2 11/16	3 3/8	3 5/8
G	DIA. OF WHEEL	2 1/2	2 1/2	2 3/4	3 1/4	3 1/4	4 1/16	4 3/4
H	DIA. OF STEM	5/16	5/16	3/8	7/16	7/16	17/32	5/8
J	DIA. OF STUFFING BOX	17/32	17/32	9/16	3/4	3/4	7/8	1 1/16
K	DEPTH OF STUFFING BOX	1/2	1/2	9/16	3/4	3/4	13/16	15/16
L	DIA. OF COLUMN	35/64	35/64	43/64	27/32	27/32	27/32	1 1/16
M	CENTER TO TOP OF BONNET	2 5/8	2 5/8	3	3 29/32	3 29/32	4 1/4	5 1/8
X	CENTER TO TOP OF STUFFING BOX	12	12	12	12	13	13	14
Y	LIFT	11/32	11/32	17/32	9/16	9/16	25/32	1 1/32

CRYOGENIC BRONZE SWING CHECK VALVES

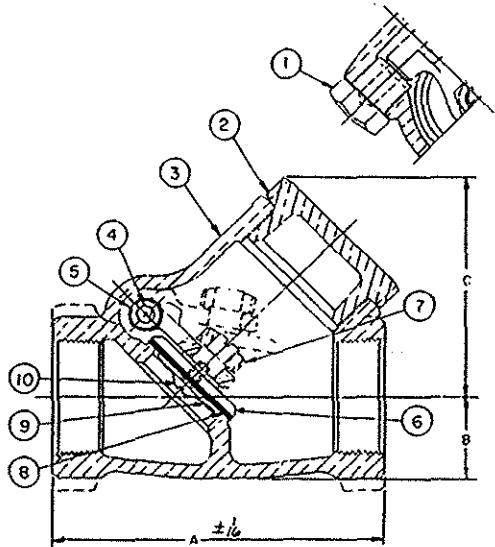

Soft Seat Valves
Class 200-Fig. 7K0560TE
Class 300-Fig. 7K0563TE
Sizes, 3/8" through 3"

Metallic Disc Valves
Class 200-Fig. 700560TE
Class 300-Fig. 700563TE
Sizes, 3/8" through 3"

CLASS 200 and 300 SCREWED-IN CAP

PRESSURE/TEMPERATURE RATINGS

See Materials and Engineering Data Section

MATERIALS (Soft Seat Valves)

	DESCRIPTION	MATERIAL	ASTM Spec.
1	SIDE PLUG	BRASS	B-16
2	CAP	BRONZE	B-61
3	BODY	BRONZE	B-61
4	CARRIER PIN	BRASS	B-16
5	CARRIER	BRONZE	B-62
6	DISC HOLDER	BRONZE	B-61
7	DISC NUT	BRASS	B-16
8	DISC	PCTFE	COMMERCIAL
9	WASHER	BRASS	B-16
10	SCREW	BRASS	B-16

DIMENSIONS (Inches) Class 200

SIZE OF VALVE	3/8	1/2	3/4	1	1 1/2	2	2 1/2	3
A END TO END	2 3/8	2 3/4	3 1/8	3 3/8	5	6 1/8	7 1/4	8 1/2
C CENTER TO TOP	1 3/8	1 11/16	2	2 3/8	3 1/2	4 1/4	5 1/16	5 7/8

DIMENSIONS (Inches) Class 300

SIZE	3/8	1/2	3/4	1	1 1/2	2	2 1/2	3
A END TO END	2 1/2	2 7/8	3 1/4	3 3/4	5 1/8	6 3/8	7 1/2	8 3/4
C CENTER TO TOP	1 1/2	1 13/16	2 1/8	2 1/2	3 9/16	4 3/8	5 3/16	6

CLASS 200 SILVER BRAZE TUBING ENDS

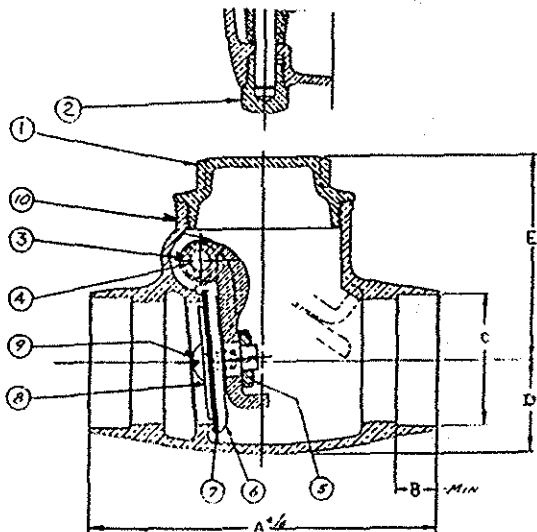

Fig. 7K2825SBT Soft Seat
Sizes, 1/2" through 3"
Fig. 702825SBT (Metallic Disc)
Sizes, 1/2" through 3"

Valves Cleaned for use in oxygen service and packaged to prevent contamination.

MATERIALS (Soft Seat Valves)

	DESCRIPTION	MATERIAL	ASTM Spec.
1	CAP (1/2"-3/4")	BRASS	B-16
	(1"-3")	BRONZE	B-61
2	SIDE PLUG	BRASS	B-16
3	CARRIER (1/2"-1")	BRASS	B-124
	(1"-3")	BRONZE	B-61
4	CARRIER PIN	BRASS	B-16
5	DISC NUT	BRASS	B-16
6	DISC HOLDER 1/2" & 3/4"	BRASS	B-16
	1"-3"	BRONZE	B-61
7	DISC	PCTFE	Commercial
8	WASHER	BRASS	B-16
9	SCREW	BRASS	B-16
10	BODY	BRONZE	B-61

DIMENSIONS (Inches) (Class 200)

SIZE	1/2	3/4	1	1 1/2	2	2 1/2	3
A END TO END	3	3 3/8	3 3/4	4 3/4	5 1/2	7 1/4	8 3/8
B DEPTH OF SOCKET	3/8	13/32	7/16	5/8	21/32	25/32	53/64
C DIA. OF SOCKET	MAX.	.631	.881	1.132	1.633	2.133	2.633
	MIN.	.627	.877	1.128	1.628	2.128	2.628
D CENTER TO BOTTOM	5/8	3/4	7/8	1 1/4	1 1/2	1 13/16	2 1/8
E CENTER TO TOP	1 3/8	1 11/16	2 1/16	2 15/16	3 5/16	3 15/16	4 1/2

CRYOGENIC BRONZE LIFT CHECK VALVES

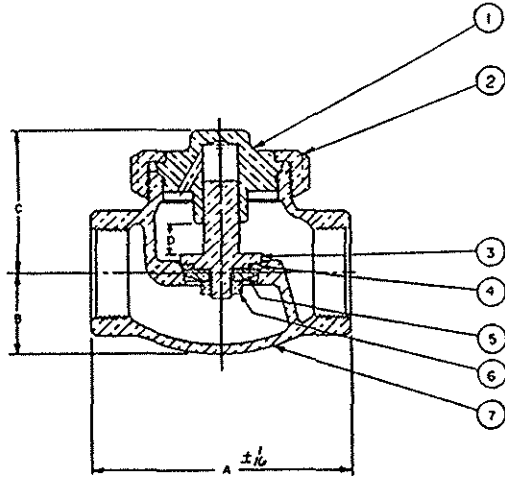

Class 200
Fig. 7K0116TE-Soft Seat Sizes: 1/4" to 2"
Fig. 700116TE-Metallic Seat Sizes: 1/4" to 2"

Class 300
Fig. 7K0126-Soft Seat Sizes: 1/4" to 2"
Fig. 700126-Metallic Disc Sizes: 1/4" to 2"

CLASS 200 and 300 UNION CAP

PRESSURE/TEMPERATURE RATINGS

See Materials and Engineering Data Section

MATERIALS (Soft Seat Valves)

DESCRIPTION		MATERIAL	ASTM Spec.
1 DISC GUIDE	1/4-1	SI. BRONZE	B-371 C69400
	1 1/2-2	BRONZE	B-61
2 BONNET RING		BRONZE	B-61
3 DISC HOLDER		SI BRONZE	B-371 C69400
4 DISC INSERT		PCTFE	COMMERCIAL
5 DISC PLATE		BRASS	B-16
6 DISC NUT		SI BRONZE	B-371 C69400
7 BODY		BRONZE	B-61

DIMENSIONS (Inches) (Class 200)

SIZE		1/4	3/8	1/2	3/4	1	1 1/2	2
A	END TO END	2 1/8	2 1/4	2 1/2	3	3 9/16	4 5/8	5 3/4
B	CENTER TO BOTTOM	9/16	9/16	1/4	15/16	1 1/8	1 1/2	1 7/8
C	CENTER TO TOP	1 13/32	1 13/32	1 1/2	1 13/16	2 1/16	2 27/32	3 23/32
D	LIFT	5/16	5/16	5/16	3/8	7/16	21/32	15/16

DIMENSIONS (Inches) (Class 300)

SIZE		1/4	3/8	1/2	3/4	1	1 1/2	2
A	END TO END (TE)	2 1/4	2 3/8	2 5/8	3 1/4	3 13/16	4 7/8	6
B	CENTER TO BOTTOM	19/32	19/32	25/32	1	1 13/16	1 19/32	1 31/32
C	CENTER TO TOP	1 13/32	1 13/32	1 1/2	1 13/16	2 1/8	2 19/32	3 25/32
D	LIFT	3/16	3/16	3/16	9/32	5/16	7/16	9/16

CLASS 200 SILVER BRAZE TUBING ENDS

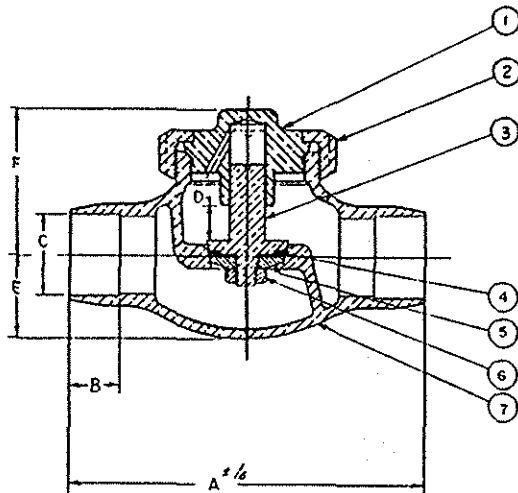

Class 200
Fig. 7K2856 SBT Soft Seat Sizes: 1/4" thru 2"
Fig. 702856 SBT Metallic Disc Sizes: 1/4" thru 2"

PRESSURE/TEMPERATURE RATINGS

See Materials and Engineering Data Section

MATERIALS (Soft Seat Valves)

DESCRIPTION		MATERIAL	ASTM Spec.
1 DISC GUIDE	1/4-1	SI. BRONZE	B-371 C69400
	1 1/2-2	BRONZE	B-61
2 BONNET RING		BRONZE	B-61
3 DISC HOLDER		SI BRONZE	B-371 C69400
4 DISC INSERT		PCTFE	COMMERCIAL
5 DISC PLATE		BRASS	B-16
6 DISC NUT		SI BRONZE	B-371 C69400
7 BODY		BRONZE	B-61

DIMENSIONS (Inches)

SIZE		1/4	3/8	1/2	3/4	1	1 1/2	2
A	END TO END	S.B.T.	2 1/2	3	3 1/4	3 3/4	4 1/4	5 1/2
B	DEPTH OF SOCKET	S.B.T.	17/64	5/16	3/8	13/32	7/16	5/8
C	DIA. OF SOCKET	MAX.	.381	.506	.631	.881	1.132	1.633
		MIN.	.377	.502	.627	.877	1.128	1.628
D	LIFT		5/16	5/16	5/16	3/8	7/16	21/32
E	CENTER TO BOTTOM		9/16	9/16	1/4	15/16	1 1/8	1 1/2
F	CENTER TO TOP		1 13/32	1 13/32	1 1/2	1 13/16	2 1/16	2 27/32

Valves Cleaned for use in oxygen service and packaged to prevent contamination.

CRYOGENIC STAINLESS STEEL GATE VALVES

CLASS 200 SCREWED-IN BONNET

PRESSURE/TEMPERATURE RATINGS

In accordance with ASME B16.34

See Materials and Engineering Data Section

MATERIALS

DESCRIPTION	MATERIAL	ASTM Spec.
1 WHEEL NUT	STEEL	COMMERCIAL
2 HANDWHEEL	MAL. IRON	COMMERCIAL
3 STEM	SIL. BRZ	B-371 C69400
4 PACKING GLAND	STAINLESS STEEL	A-276 TYPE 316
5 PACKING NUT	STAINLESS STEEL	A-276 TYPE 316
6 PACKING	PTFE	COMMERCIAL
7 PACKING SLEEVE	STAINLESS STEEL	A-276 TYPE 316
8 EXTENSION COLUMN	STAINLESS STEEL	A-312 TYPE 304
9 BONNET	STAINLESS STEEL	A-351 GRADE CF8M
10 BODY	STAINLESS STEEL	A-351 GRADE CF8M
11 DISC	BRONZE	B-61
12 IDENT. PLATE	ALUMINUM	COMMERCIAL

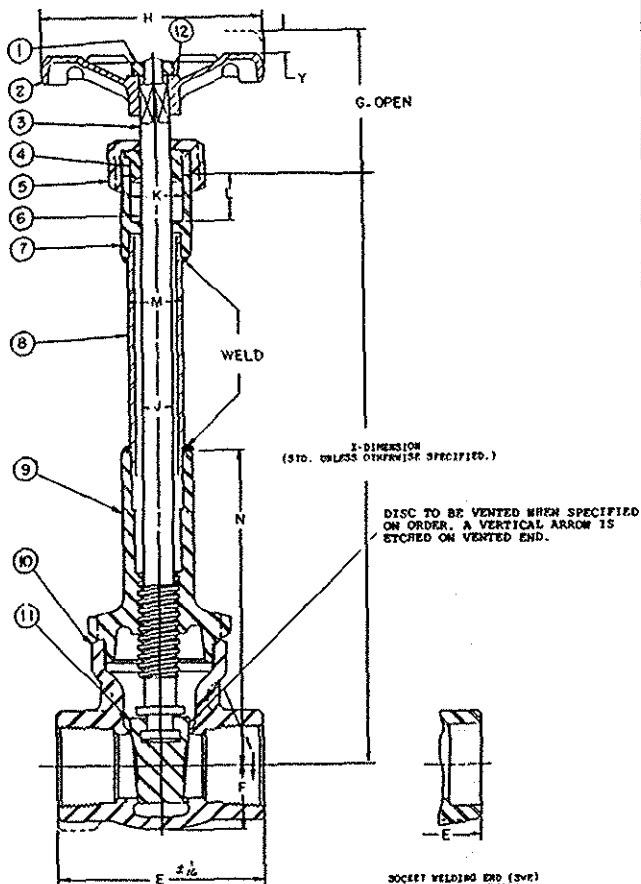

FEATURES

- Valves Cleaned for oxygen service and packaged to prevent contamination.
- Also available with Non Extended Stems

DIMENSIONS (Inches)

SIZE	¼	3/8	½	¾	1	1 ½	2
E END TO END (TE) & (BWE)	1 ¾	2	2 ¼	2 ½	3 ¼	3 ¾	4
F CENTER TO BOTTOM	9/16	9/16	11/16	13/16	1	1 7/16	1 ¾
G PACKING SLEEVE TO TOP-OPEN	2 1/8	2 1/8	2 11/32	2 7/8	3 9/32	4 1/8	4 13/16
H DIA OF HANDWHEEL	2 ½	2 ½	2 ¾	3	3 ¼	4 1/16	4 ¾
J DIA OF STEM	11/32	11/32	3/8	27/64	15/32	9/16	21/32
K DIA OF STUFFING BOX	9/16	9/16	9/16	11/16	13/16	1	1 1/8
L DEPTH OF STUFFING BOX	½	½	9/16	11/16	¾	7/8	1
M DIA OF COLUMN	9/16	9/16	11/16	11/16	27/32	1 1/16	1 1/16
N CENTER TO TOP OF BONNET	2 13/16	2 13/16	3 ¼	4 3/16	4 15/16	6 13/16	8 3/8
X CENTER TO TOP OF STUFFING BOX	13	13	13	13	14	14	16
Y LIFT	½	½	5/8	7/8	1 1/8	1 5/8	2 1/8

Fig 701832 T.E., S.W.E.
Sizes ¼" through 2"

CRYOGENIC STAINLESS STEEL GATE VALVES

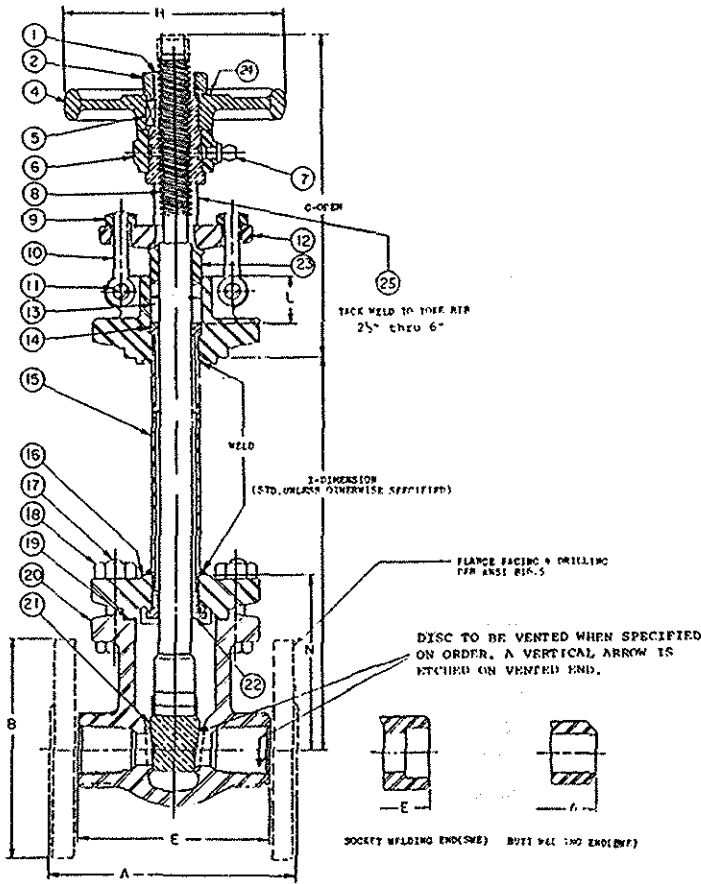

CLASS 150-200-300

PRESSURE/TEMPERATURE RATINGS

In accordance with ASME B16.34

See Materials and Engineering Data Section

MATERIALS

DESCRIPTION	MATERIAL	ASTM Spec.
1 YOKE BUSHING	SI. BR.	B-371 C69400
2 YOKE BUSH LOCKNUT	ST. BR.	A-582 TYPE 416
4 HANDWHEEL	MAL. IRON	A 47 GRADE 32510
5 HANDWHEEL KEY	STEEL	COMMERCIAL
6 YOKE	STAINLESS STEEL	A-351 GRADE CF8M
7 GREASE FITTING	STEEL	COMMERCIAL
8 STEM	STAINLESS STEEL	A 582 TYPE 303
9 GLAND EYEBOLT NUT	STAINLESS STEEL	300 SERIES
10 GLAND EYEBOLT	STAINLESS STEEL	300 SERIES
11 GLAND EYEBOLT PIN	STAINLESS STEEL	300 SERIES
12 GLAND FLANGE	STAINLESS STEEL	A 182 GRADE F 304
13 PACKING	PTFE	COMMERCIAL
14 PACKING COLLAR	SILICON BRONZE	B 371 C69400
15 EXTENSION COLUMN	STAINLESS STEEL	A 312 TYPE 304
16 BONNET	STAINLESS STEEL	A-351 GRADE CF8M
17 BONNET BOLT	STAINLESS STEEL	A-193 GR. B8
18 BONNET BOLT NUT	STAINLESS STEEL	A-194 GR. 8
19 GASKET	FLEXIBLE GRAPHITE	COMMERCIAL
20 BODY (FE) **	STAINLESS STEEL	A-351 GR. CF8M
21 WEDGE	BRONZE	B 61
22 BONNET BUSHING	SI. BR.	B-371 C69400
23 GLAND	SI. BR.	B-371 C69400
24 IDENT PLATE	ALUMINUM	COMMERCIAL
25 IDENT PLATE	300 SER. S.S.T.	COMMERCIAL

** TE, SWE, BWE ASTM Grade CF3M

FEATURES

- Flexible Wedge Sizes 3" through 6"
- Valves Cleaned for oxygen service and packaged to prevent contamination.
- Also available with Non Extended Stems

Class 200 Fig. 702490 T.E., S.W.E.

Sizes, 1/4" to 2"

Class 150 Fig. 702491 F.E., B.W.E.

Sizes, 1/2" to 2"

Class 150 Fig. 702456 F.E., B.W.E.

Sizes, 2 1/2" to 6"

Class 300 Fig. 702466 T. E., S.W.E.

Sizes, 1/4" to 2"

Class 300 Fig. 702467 F.E., B.W.E.

Sizes, 1/2" to 6"

DIMENSIONS (Inches) Class 150-200

Size	1/4	3/8	1/2	3/4	1	1 1/2	2	2 1/2	3	4	5
A FACE TO FACE (F.E.)			4 1/4	4 5/8	5	6 1/4	7	7 1/2	8	9	10 1/2
A FACE TO FACE (B.W.E.)			4 1/4	4 5/8	5	6 1/4	7	7 1/2	8	9	10 1/2
B DIA. OF FLANGES			3 1/4	3 7/8	4 1/4	5	6	7	7 1/2	9	11
C DIA. OF RAISED FACE			1 3/8	1 11/16	2	2 7/8	3 5/8	4 1/8	5	6 3/16	8 1/2
D THICKNESS OF FLANGES			3/8	13/32	7/16	9/16	5/8	11/16	1/2	15/16	1
E END TO END (T.E. & S.W.E.)	2 1/8	2 1/8	3	3 1/2	4	4 5/8	5				
F CENTER TO BOTTOM	3/4	3/4	7/8	1	1 1/4	1 5/16	1 7/8	2 1/16	2 5/16	3	4 1/8
G BOTTOM OF YOKE FLANGE TO TOP - OPEN	5 1/8	5 1/8	5 9/16	6 1/4	6 3/4	8 3/8	9 11/16	10 3/8	11 1/4	13 9/16	18 3/8
H DIA. OF WHEEL	3	3	3 1/2	4	4 1/2	5	7	7	9	11	
J DIA. OF STEM	7/16	7/16	1/2	9/16	5/8	13/16	13/16	13/16	15/16	1	
K DIA. OF STUFFING BOX	1/4	1/4	13/16	15/16	1	1 1/4	1 5/16	1 5/16	1 5/16	1 1/2	1 5/8
L DEPTH OF STUFFING BOX	11/16	11/16	13/16	15/16	1	1 7/32	1 7/16	1 11/16	1 11/16	1 11/16	2 1/4
M DIA. OF COLUMN	11/16	11/16	27/32	27/32	1 1/16	1 1/16	1 5/16	1 5/16	1 5/16	1 21/32	1 21/32
N CENTER TO TOP OF BONNET	2 1/16	2 1/16	2 13/16	3 1/16	3 1/2	4 11/16	5 9/16	5 5/8	6 5/16	7 7/8	11 1/4
O YOKE FLANGE SQUARE	2 3/8	2 3/8	2 5/8	3	3 7/16	4 1/4	4 1/4				
X CENTER TO BOTTOM OF YOKE FLANGE (STD)	13	13	13	13	14	14	16	19	19	20	24
Y LIFT	1/2	1/2	5/8	15/16	1 3/16	1 3/4	2 1/4	2 3/16	3 1/16	4 1/16	6 1/16

DIMENSIONS (Inches) Class 300

Size	1/4	3/8	1/2	3/4	1	1 1/2	2	2 1/2	3	4	5
A FACE TO FACE (F.E.)			5 1/2	6	6 1/2	7 1/2	8 1/2	9 1/2	11 1/8	12	15 7/8
A FACE TO FACE (B.W.E.)			5 1/2	6	6 1/2	7 1/2	8 1/2	9 1/2	11 1/8	12	15 7/8
B DIA. OF FLANGES			3 3/4	4 5/8	4 7/8	6 1/8	6 1/2	7 1/2	8 1/4	10	12 1/2
C DIA. OF RAISED FACE			1 3/8	1 11/16	2	2 7/8	3 5/8	4 1/8	5	6 3/16	8 1/2
D THICKNESS OF FLANGES			9/16	5/8	11/16	13/16	1/2	1	1 1/8	1 1/4	17/16
E END TO END (T.E. & S.W.E.)	2 1/8	2 1/8	3	3 1/2	4	4 5/8	5				
F CENTER TO BOTTOM	3/4	3/4	7/8	1	1 1/4	1 9/16	1 7/8	2 1/16	2 5/16	3	4 1/8
G BOTTOM OF YOKE FLANGE TO TOP - OPEN	5 1/8	5 1/8	5 9/16	6 1/4	6 3/4	8 3/8	9 11/16	10 3/8	11 1/4	13 9/16	18 7/8
H DIA. OF WHEEL	3	3	3 1/2	4	4 1/2	5	7	7	9	10	14
J DIA. OF STEM	7/16	7/16	1/2	9/16	5/8	13/16	13/16	13/16	15/16	1 1/8	
K DIA. OF STUFFING BOX	3/4	3/4	13/16	15/16	1	1 1/4	1 5/16	1 5/16	1 5/16	1 1/2	1 3/4
L DEPTH OF STUFFING BOX	11/16	11/16	13/16	15/16	1	1 7/32	1 7/16	1 11/16	1 11/16	1 11/16	2 1/2
M DIA. OF COLUMN	11/16	11/16	27/32	27/32	1 1/16	1 1/16	1 5/16	1 5/16	1 5/16	1 21/32	1 21/32
N CENTER TO TOP OF BONNET	2 1/16	2 1/16	2 13/16	3 1/16	3 1/2	4 11/16	5 9/16	5 5/8	6 5/16	7 7/8	11 1/4
O YOKE FLANGE SQUARE	2 3/8	2 3/8	2 5/8	3	3 7/16	4 1/4	4 1/4				
X CENTER TO BOTTOM OF YOKE FLANGE (STD)	13	13	13	13	14	14	16	19	19	20	24
Y LIFT	1/2	1/2	5/8	15/16	1 3/16	1 3/4	2 1/4	2 3/16	3 1/16	4 1/16	6 1/16

CRYOGENIC STAINLESS STEEL GATE VALVES

CLASS 150 and 300

PRESSURE/TEMPERATURE RATINGS

In accordance with ASME B16.34

See Materials and Engineering Data Section

MATERIALS

DESCRIPTION	MATERIAL	ASTM Spec.
1 UPPER BUSHING	BRONZE	B-61
2 HANDWHEEL NUT	MAL. IRON	A-47 GRADE 32510
3 HANDWHEEL	MAL. IRON	A-47 GRADE 32510
4 HANDWHEEL KEY	STEEL	COMMERCIAL
5 YOKE ARM EAR BOLT	STAINLESS STEEL	300 SERIES
6 YOKE ARM EAR NUT	STAINLESS STEEL	300 SERIES
7 STEM	STAINLESS STEEL	A-582 TYPE 303
8 GLAND EYEBOLT NUT	STAINLESS STEEL	300 SERIES
9 GLAND EYEBOLT	STAINLESS STEEL	300 SERIES
10 GLAND EYEBOLT PIN	STAINLESS STEEL	300 SERIES
11 GLAND FLANGE	STAINLESS STEEL	A-351 GRADE CF8M
12 PACKING	PTFE	COMMERCIAL
13 STUFFING BOX	STAINLESS STEEL	A-351 GRADE CF8M
14 EXTENSION COLUMN	STAINLESS STEEL	A-269 TYPE 304
15 BONNET	STAINLESS STEEL	A-351 GRADE CF8M
16 BONNET BUSHING	BRASS	B-16
17 GASKET	FLEXIBLE GRAPHITE	COMMERCIAL
18 BONNET BOLT NUT	STAINLESS STEEL	300 SERIES
19 BONNET BOLT	STAINLESS STEEL	300 SERIES
20 BODY*	STAINLESS STEEL	A-351 GRADE CF8M
21 WEDGE FLEX	BRONZE	B-61
22 BODY BOLT	STAINLESS STEEL	A-193 GRADE B8
23 BODY NUT	STAINLESS STEEL	A-194 GRADE 8
24 IDENT. PLATE	STAINLESS STEEL	300 SERIES
25 YOKEARM	STAINLESS STEEL	A-351 GRADE CF8M
26 GREASE FITTING	STEEL	COMMERCIAL
27 PACKING WASHER	SI. BR.	B-371 C69400
28 GLAND	SI. BR.	B-371 C69400

*BWE) ASTM A-351 GRADE CF3M

FEATURES

- Valves Cleaned for oxygen service and packaged to prevent contamination.
- Also available with Non Extended Stems

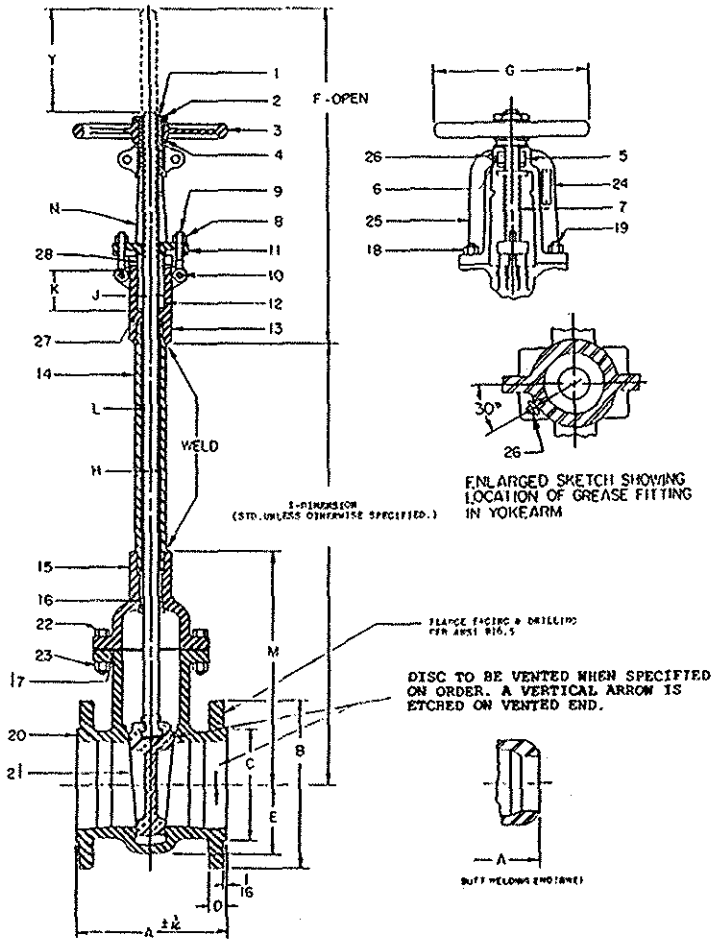

Class 150 Fig. 702456 F.E., B.W.E.
Sizes, 8" through 12"

Class 300 Fig. 702467 F.E., B.W.E.
Sizes, 8" through 12"

DIMENSIONS (Inches) Class 150

SIZE	8	10	12
A FACE TO FACE (FE & BWE)	11 1/2	13	14
B DIA. OF FLANGES	13 1/2	16	19
C DIA. OF RAISED FACE	10 5/8	12 3/4	15
D THICKNESS OF FLANGES	1 1/8	1 3/16	1 1/4
E CENTER TO BOTTOM	5 11/16	7 3/16	8 3/8
F BOTTOM OF YOKE TO TOP-OPEN	25 1/8	30 5/8	37 1/4
G DIA. OF WHEEL	17	22	22
H DIA. OF STEM	1 3/8	1 1/2	1 5/8
J DIA. OF STUFFING BOX	2 1/64	2 17/64	2 25/64
K DEPTH OF STUFFING BOX	1 7/8	2 1/4	2 1/4
L DIA. OF COLUMN	2 15/32	2 15/32	3 1/4
M CENTER TO TOP OF BONNET	17 1/2	22 1/2	26 1/4
N MAX DIA. OF YOKE ARMS	10 1/8	11 5/8	13 1/4
X CENTER TO BOTTOM OF YOKE	28	32	36
Y LIFT	8 1/2	10 9/16	12 13/16

DIMENSIONS (Inches) Class 300

SIZE	8	10	12
A FACE TO FACE (FE & BWE)	16 1/2	18	19 3/4
B DIA. OF FLANGES	15	17 1/2	20 1/2
C DIA. OF RAISED FACE	10 5/8	12 3/4	15
D THICKNESS OF FLANGES	1 5/8	1 7/8	2
E CENTER TO BOTTOM	5 11/16	7 3/16	8 3/8
F BOTTOM OF YOKE TO TOP-OPEN	27	31 7/8	37 1/4
G DIA. OF WHEEL	17	22	22
H DIA. OF STEM	1 3/8	1 1/2	1 5/8
J DIA. OF STUFFING BOX	2 1/64	2 17/64	2 25/64
K DEPTH OF STUFFING BOX	1 7/8	2 1/4	2 1/4
L DIA. OF COLUMN	2 15/32	2 15/32	3 1/4
M CENTER TO TOP OF BONNET	17 1/2	22 1/2	26 1/4
N MAX DIA. OF YOKE ARMS	10 1/8	11 5/8	13 1/4
X CENTER TO BOTTOM OF YOKE	28	32	36
Y LIFT	8 1/2	10 9/16	12 13/16

CRYOGENIC STAINLESS STEEL GATE VALVES

CLASS 600

PRESSURE/TEMPERATURE RATINGS

In accordance with ASME B16.34

See Materials and Engineering Data Section

MATERIALS

DESCRIPTION	MATERIAL	ASTM Spec.
1 YOKE BUSHING	SI. BR.	B-371 C69400
2 YOKE BUSH LOCKNUT	STAINLESS	A-582 TYPE 416
4 HANDWHEEL	MAL. IRON	A-47 GRADE 32510
5 HANDWHEEL KEY	STEEL	COMMERCIAL
6 YOKE	STAINLESS STEEL	ASTM A-351 GRADE CF8M
7 GREASE FITTING	STEEL	COMMERCIAL
8 STEM	STAINLESS STEEL	A-582 TYPE 303
9 GLAND EYEBOLT NUT	STAINLESS STEEL	300 SERIES
10 GLAND EYEBOLT	STAINLESS STEEL	300 SERIES
11 GLAND EYEBOLT PIN	STAINLESS STEEL	300 SERIES
12 GLAND FLANGE	STAINLESS STEEL	A-182 GRADE F304
13 PACKING	PTFE	COMMERCIAL
14 PACKING COLLAR	SI. BR.	B-371 C69400
15 EXTENSION COLUMN	STAINLESS STEEL	A-312 TYPE 304
16 BONNET	STAINLESS STEEL	A-351 GRADE CF8M
17 BONNET BOLT	STAINLESS STEEL	A-193 GR. B8
18 BONNET BOLT NUT	STAINLESS STEEL	A-194 GR. 8
19 GASKET	FLEXIBLE GRAPHITE	COMMERCIAL
20 BODY (F.E.)*	STAINLESS STEEL	A-351 GRADE CF8M
21 WEDGE	BRONZE	B-61
22 BONNET BUSHING	SI. BR.	B-371 C69400
23 GLAND	SI. BR.	B-371 C69400
24 IDENT. PLATE	ALUMINUM	COMMERCIAL

* (TE) (SWE) & (BWE) ASTM A-351, GRADE CF-3M

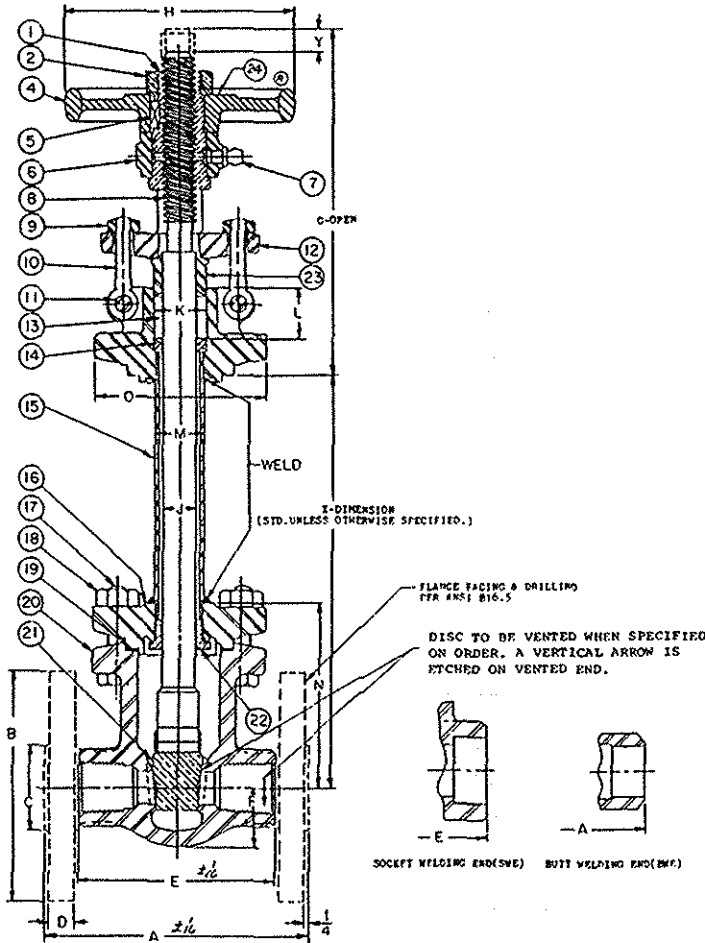

FEATURES

- Valves Cleaned for oxygen service and packaged to prevent contamination.
- Also available with Non Extended Stems

Fig. 701972 T.E., S.W.E.
Sizes, 1/4" through 2"

Fig. 701973 F.E., B.W.E.
Sizes, 1/2" through 2"

DIMENSIONS (Inches)

SIZE OF VALVE	1/4	3/8	1/2	3/4	1	1 1/2	2
A FACE TO FACE (F.E.)			6 1/2	7 1/2	8 1/2	9 1/2	11 1/2
FACE TO FACE (B.W.E.)			6 1/2	7 1/2	8 1/2	9 1/2	11 1/2
B DIA. OF FLANGES			3 3/4	4 5/8	4 7/8	6 1/8	6 1/2
C DIA. OF RAISED FACE			1 3/8	1 11/16	2	2 7/8	3 5/8
D THICKNES OF FLANGES			9/16	5/8	11/16	7/8	1
E END TO END (T.E. & S.W.E.)	2 1/8	2 1/8	3	3 1/2	4	5	5 3/4
F CENTER TO BOTTOM	3/4	3/4	15/16	1 1/16	1 5/16	1 11/16	2 1/16
G BOTTOM OF YOKE FLANGE TO TOP-OPEN	5 1/8	5 1/8	5 9/16	6 1/4	6 3/4	8 3/8	9 11/16
H DIA. OF WHEEL	3	3	3 1/2	4	5	7	8
J DIA. OF STEM	7/16	7/16	1/2	9/16	5/8	3/4	13/16
K DIA. OF STUFFING BOX	3/4	3/4	13/16	15/16	1	1 1/4	1 5/16
L DEPTH OF STUFFING BOX	11/16	11/16	13/16	15/16	1	1 7/32	1 7/16
M DIA. OF COLUMN	11/16	11/16	27/32	27/32	1 1/16	1 1/16	1 5/16
N CENTER TO TOP OF BONNET	2 1/16	2 1/16	2 13/16	3 1/16	3 1/2	4 11/16	5 3/4
O YOKE FLANGE SQUARE	2 3/8	2 3/8	2 5/8	3	3 7/16	4 1/4	4 1/2
X CENTER TO BOTTOM OF YOKE FLANGE (STD)	13	13	13	13	14	14	16
Y LIFT	1/2	1/2	5/8	15/16	1 3/16	1 3/4	2 1/4

CRYOGENIC STAINLESS STEEL GLOBE VALVES

CLASS 200

PRESSURE/TEMPERATURE RATINGS

In accordance with ASME B16.34

See Materials and Engineering Data Section

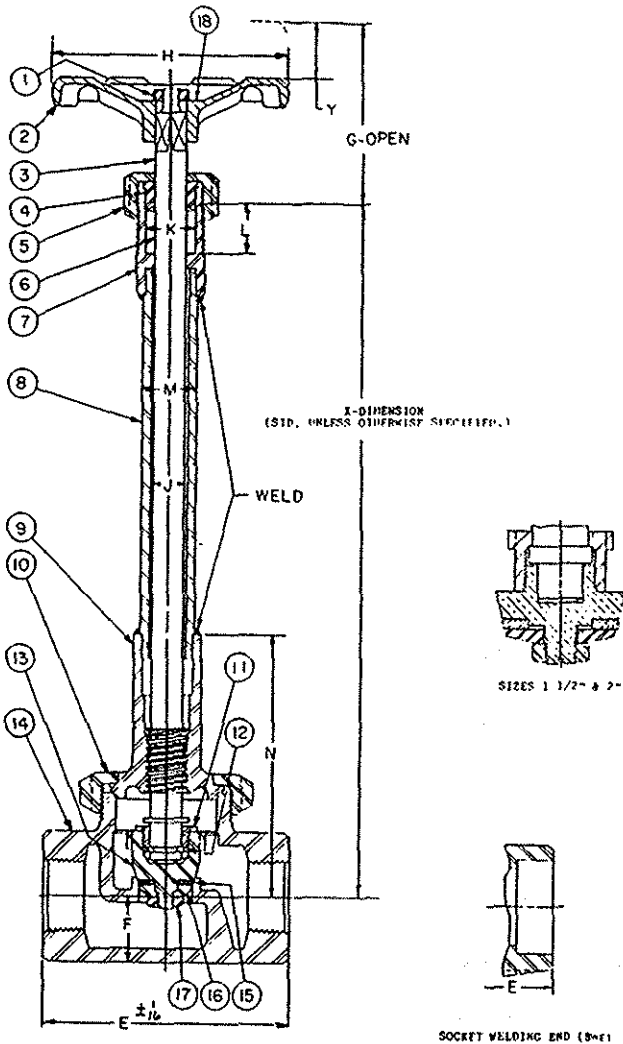

MATERIALS (Soft Seat Valves)

DESCRIPTION	MATERIAL	ASTM Spec.
1 WHEEL NUT	STEEL	A-563 GRADE A OR B
2 HANDWHEEL	MAL. IRON	A-47 GRADE 32510
3 STEM	SIL. BRZ	B-371 C69400
4 PACKING GLAND	STAINLESS STEEL	A-276 TYPE 316
5 PACKING NUT	STAINLESS STEEL	A-276 TYPE 316
6 PACKING	PTFE	COMMERCIAL
7 PACKING SLEEVE	STAINLESS STEEL	A-276 TYPE 316
8 EXTENSION COLUMN	STAINLESS STEEL	A-312 TYPE 304
9 BONNET**	STAINLESS STEEL	A-351 GRADE CF8M
10 BONNET RING	STAINLESS STEEL	A-351 GRADE CF8M
11 LOCKNUT	STAINLESS STEEL	A-276 TYPE 316
12 HORSESHOE RING	STAINLESS STEEL	300 SERIES
13 DISC HOLDER	SI. BR.	B-371 C69400
14 BODY	STAINLESS STEEL	A-351 GRADE CF3M
15 DISC	PCTFE	COMMERCIAL
16 DISC PLATE	BRASS	B-16
17 DISC NUT	STAINLESS STEEL	A-276 TYPE 316
18 IDENT. PLATE	ALUMINUM	COMMERCIAL
(METALLIC DISC VALVES)		
15A DISC	SIL. BRZ.	B-371 C69400

** 1/4", 3/8", & 1/2" VA. SIZES — ASTM A-276, TYPE 316

FEATURES

- Valves Cleaned for oxygen service and packaged to prevent contamination.
- Also available with Non Extended Stems

(Soft Seat Valve)
Fig. 7K1861 T.E., S.W.E
Sizes, 1/4" through 2"

(Metallic Disc Valve)
Fig. 701861 T.E., S.W.E.
Sizes, 1/4" through 2"

DIMENSIONS (Inches)

SIZE	1/4	3/8	1/2	3/4	1	1 1/2	2
E END TO END (TE) & (BWE)	2 7/16	2 7/16	2 7/16	3 3/8	3 3/8	5 1/2	6
F CENTER TO BOTTOM	5/8	5/8	5/8	15/16	15/16	1 1/2	1 7/8
G PACKING SLEEVE TO TOP-OPEN	1 3/4	1 3/4	1 3/4	2 5/16	2 5/16	2 7/8	3 1/8
H DIA. OF HANDWHEEL	2 3/4	2 3/4	2 3/4	3 1/4	3 1/4	4 1/16	4 3/4
J DIA. OF STEM	11/32	11/32	11/32	27/64	27/64	9/16	21/32
K DIA. OF STUFFING BOX	9/16	9/16	9/16	11/16	11/16	1	1 1/8
L DEPT OF STUFFING BOX	1/2	1/2	1/2	11/16	11/16	7/8	1
M DIA. OF COLUMN	11/16	11/16	11/16	11/16	11/16	1 1/16	1 1/16
N CENTER TO TOP OF BONNET	2 11/16	2 11/16	2 11/16	3 5/8	3 5/8	5 5/16	6 1/16
X CENTER TO TOP OF STUFFING BOX	12	12	12	12	13	13	14
Y LIFT	3/8	3/8	3/8	7/16	7/16	5/8	11/16

CRYOGENIC STAINLESS STEEL GLOBE VALVES

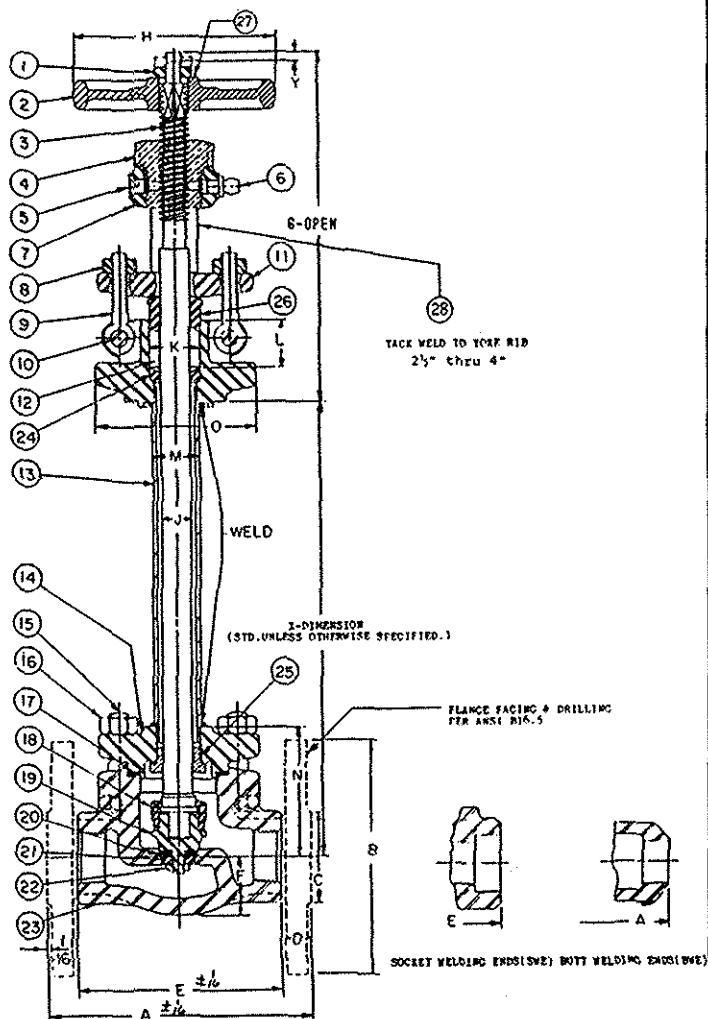

Fig. No. (Soft Seat Valves)
Class 150-7K2475 F.E., B.W.E. Sizes, 1/2" to 4"
Class 200-7K2474 T.E., S.W.E. Sizes, 1/4" to 3"
Class 300-7K2446 T.E., S.W.E. Sizes, 1/4" to 3"
Class 300-7K2447 F.E., B.W.E. Sizes, 1/2" to 4"

DIMENSIONS (Inches) Class 150, 200

SIZE	1/4	3/8	1/2	3/4	1	1 1/2	2	2 1/2	3	4
A FACE TO FACE (F.E. & B.W.E.)			4 1/4	4 5/8	5	6 1/4	8	8 1/2	9 1/2	11 1/4
B DIA. OF FLANGES			3 1/2	3 7/8	4 1/4	5	6	7	7 1/2	9
C DIA. OF RAISED FACE			1 3/8	1 11/16	2	2 7/8	3 5/8	4 1/8	5	6 3/16
D THICKNESS OF FLANGES			3/8	13/32	7/16	9/16	5/8	11/16	3/4	15/16
E END TO END (T.E. & S.W.E.)	2 7/8	2 7/8	2 7/8	3 1/4	3 3/4	5 1/4	6	6 3/4	8	
F CENTER TO BOTTOM	5/8	5/8	5/8	3/4	15/16	1 1/2	1 7/8	2 1/8	2 11/16	3 5/8
G BOTTOM OF YOKE FLG TO TOP-OPEN	5 1/4	5 1/2	5 1/2	5 7/8	6 1/2	7 5/8	8 3/16	9 1/8	10 5/16	13 11/16
H DIA. OF WHEEL	3	3	3	3 1/2	4	5	6	7	8	10
J DIA. OF STEM	7/16	7/16	7/16	1/2	9/16	11/16	1/2	13/16	15/16	1 1/8
K DIA. OF STUFFING BOX	3/4	3/4	3/4	13/16	15/16	1 1/8	1 1/4	1 5/16	1 1/2	1 3/4
L DEPT. OF STUFFING BOX	1 1/16	1 1/16	1 1/16	1 3/16	1 5/16	1 7/16	1 7/32	1 7/16	1 11/16	2 1/4
M DIA. OF COLUMN	1 1/16	1 1/16	1 1/16	27/32	27/32	1 1/16	1 1/16	1 5/16	1 5/16	1 29/32
N CENTER TO TOP OF BONNET	2 1/16	2 1/16	2 1/16	2 3/16	2 7/16	3 1/8	3 5/8	4 1/16	4 15/16	6 7/8
O YOKE FLANGE SQUARE	2 3/8	2 3/8	2 3/8	2 5/8	3	3 3/4	4 1/4	4 1/2	5 11/16	
X CENTER TO BOTTOM OF YOKE (STD)	12	12	12	12	13	13	14	14	14	16
Y LIFT	3/8	3/8	3/8	1/2	1/2	13/16	1	1 1/16	1 5/16	1 1/4

CLASS 150-200-300

PRESSURE/TEMPERATURE RATINGS

In accordance with ASME B16.34

See Materials and Engineering Data Section

MATERIALS (Soft Seat Valves)

NO.	DESCRIPTION	MATERIAL	ASTM Spec
1	WHEEL NUT	STEEL	A-563 GRADE A OR B
2	HANDWHEEL	MAL. IRON	A-47 GRADE 32510
3	STEM	STAINLESS STEEL	A-582 TYPE 303
4	YOKE BUSHING	SI. BR.	B-371 C69400
5	SET SCREW	STEEL	COMMERCIAL
6	GREASE FITTING	STEEL	COMMERCIAL
7	YOKE	STAINLESS STEEL	A-351 GRADE CF8M
8	GLAND EYEBOLT NUT	STAINLESS STEEL	300 SERIES
9	GLAND EYEBOLT	STAINLESS STEEL	300 SERIES
10	GLAND EYEBOLT PIN	STAINLESS STEEL	300 SERIES
11	GLAND FLANGE	STAINLESS STEEL	A-182 GR. F304
12	PACKING	PTFE	COMMERCIAL
13	EXTENSION COLUMN	STAINLESS STEEL	A-312 TYPE 304
14	BONNET	STAINLESS STEEL	A-351 GRADE CF8M
15	BONNET BOLT	STAINLESS STEEL	A-193 GR. B8
16	BONNET BOLT NUT	STAINLESS STEEL	A-194 GR. 8
17	GASKET	FLEXIBLE GRAPHITE	COMMERCIAL
18	DISC LOCKNUT	SI. BR.	B-371 C69400
19	DISC HOLDER	SI. BR.	B-371 C69400
20	DISC INSERT	PTFE	COMMERCIAL
21	DISC PLATE	BRASS	B-16
22	DISC NUT	STAINLESS STEEL	A-276 TYPE 316
23	BODY (F.E.)*	STAINLESS STEEL	A-351 GRADE CF8M
24	PACKING COLLAR	SI. BR.	B-371 C69400
25	BONNET BUSHING	SI. BR.	B-371 C69400
26	GLAND	SI. BR.	B-371 C69400
27	IDENT. PLATE	ALUMINUM	COMMERCIAL
28	IDENT. PLATE	300 SERIES SST	COMMERCIAL
(METALLIC DISC VALVES)			
19A	DISC	SIL. BR.	B-371 C69400

* (TE) (SWE) & (BWE) ASTM A-351, GRADE CF-3M

FEATURES

- Valves Cleaned for oxygen service and packaged to prevent contamination.
- Also available with Non Extended Stems

Fig. No. (Metallic Disc Valves)

Class 150-702475 F.E., B.W.E. Sizes, 1/2" to 4"
Class 200-702474 T.E., S.W.E. Sizes, 1/4" to 3"
Class 300-702446 T.E., S.W.E. Sizes, 1/4" to 3"
Class 300-702447 F.E., B.W.E. Sizes, 1/2" to 4"

DIMENSIONS (Inches) Class 300

SIZE	1/4	3/8	1/2	3/4	1	1 1/2	2	2 1/2	3	4
A FACE TO FACE (F.E. & B.W.E.)				6	7	8	9	10 1/4	11 1/2	12 1/4
B DIA. OF FLANGES				3 3/4	4 5/8	4 7/8	6 1/8	6 1/2	7 1/2	8 3/4
C DIA. OF RAISED FACE				1 3/8	1 11/16	2	2 7/8	3 5/8	4 1/8	5
D THICKNESS OF FLANGES				9/16	5/8	11/16	13/16	7/8	1	1 1/8
E END TO END (T.E. & S.W.E.)	2 7/8	2 7/8	2 7/8	3 1/4	3 3/4	5 1/4	6	6 3/4	8	
F CENTER TO BOTTOM	5/8	5/8	5/8	3/4	15/16	1 1/4	1 7/8	2 1/8	2 11/16	3 5/8
G BOTTOM OF YOKE FLG TO TOP-OPEN	5 1/2	5 1/2	5 1/2	5 7/8	6 1/2	7 5/8	8 3/16	9 1/8	10 5/16	14 3/8
H DIA. OF WHEEL	3	3	3	3 1/2	4	5	6	7	8	10
J DIA. OF STEM	7/16	7/16	7/16	1/2	9/16	11/16	1/2	13/16	15/16	1 1/8
K DIA. OF STUFFING BOX	3/4	3/4	3/4	13/16	15/16	1 1/8	1 1/4	1 5/16	1 1/2	1 3/4
L DEPTH OF STUFFING BOX	1 1/16	1 1/16	1 1/16	1 3/16	1 5/16	1 7/16	1 7/32	1 7/16	1 11/16	2 1/4
M DIA. OF COLUMN	1 1/16	1 1/16	1 1/16	27/32	27/32	1 1/16	1 1/16	1 5/16	1 5/16	1 29/32
N CENTER TO TOP OF BONNET	2 1/16	2 1/16	2 1/16	2 3/16	2 7/16	3 1/8	3 5/8	4 1/16	4 15/16	6 7/8
O YOKE FLANGE SQUARE	2 3/8	2 3/8	2 3/8	2 5/8	3	3 3/4	4 1/4	4 1/2	5 11/16	
X CENTER TO BOTTOM OF YOKE (STD)	12	12	12	12	13	13	14	14	14	16
Y LIFT	3/8	3/8	3/8	1/2	1/2	13/16	1	1 1/16	1 5/16	1 1/4

CRYOGENIC STAINLESS STEEL GLOBE VALVES

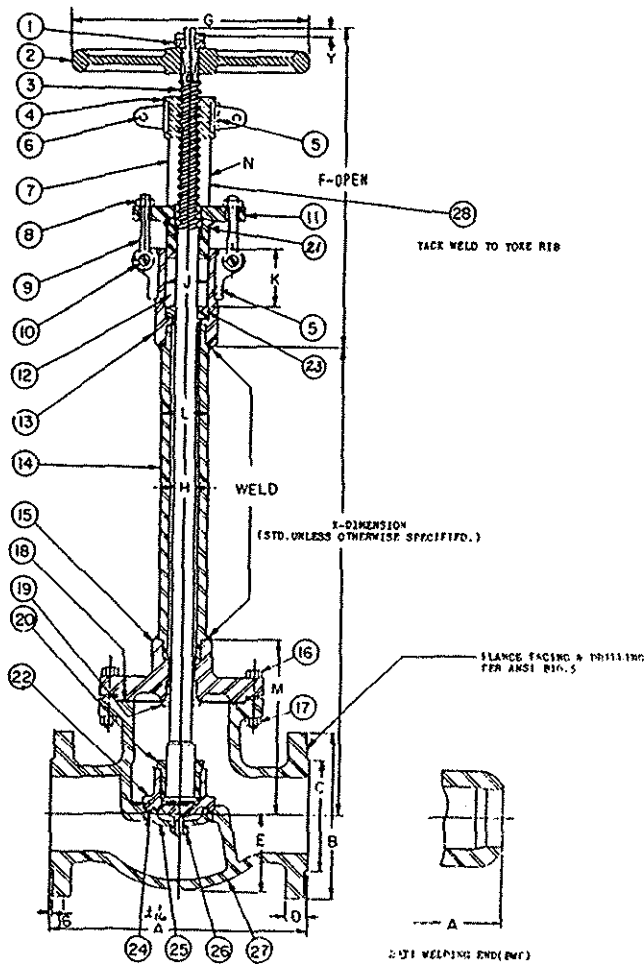

CLASS 150 and 300 PRESSURE/TEMPERATURE RATINGS

In accordance with ASME B16.34
See Materials and Engineering Data Section

MATERIALS (Soft Seat Valves)

DESCRIPTION	MATERIAL	ASTM Spec.
1 HANDWHEEL NUT	STEEL	A-563 GRADE A OR B
2 HANDWHEEL	MAL. IRON	A-47 GRADE 32510
3 STEM	STAINLESS STEEL	A-276 TYPE 316
4 STEM BUSHING	BRONZE	B-61
5 HEADLESS SET SCREW	STEEL	COMMERCIAL
6 YOKEARM BOLT & NUT	STAINLESS STEEL	300 SERIES
7 YOKE	STAINLESS STEEL	A-351 GRADE CF8M
8 GLAND EYEBOLT NUT	STAINLESS STEEL	300 SERIES
9 GLAND EYEBOLT	STAINLESS STEEL	300 SERIES
10 EYEBOLT BOLT & NUT	STAINLESS STEEL	300 SERIES
11 GLAND FLANGE	STAINLESS STEEL	A-351 GRADE CF8M
12 PACKING	PTFE	COMMERCIAL
13 YOKE	STAINLESS STEEL	A-351 GRADE CF8M
14 EXTENSION COLUMN	STAINLESS STEEL	A-269 TYPE 304
15 BONNET	STAINLESS STEEL	A-351 GRADE CF8M
16 BONNET BOLT	STAINLESS STEEL	A-193 GR. B8
17 BONNET BOLT NUT	STAINLESS STEEL	A-194 GR. 8
18 GASKET	FLEXIBLE GRAPHITE	COMMERCIAL
19 BONNET BUSHING	SILICON BRONZE	B-371 C69400
20 LOCKNUT	BRONZE	B-62
21 GLAND FOLLOWER	SILICON BRONZE	B-371 C69400
22 DISC HOLDER	BRONZE	B-62
23 PACKING COLLAR	SILICON BRONZE	B-371 C69400
24 DISC	PCTFE	COMMERCIAL
25 DISC PLATE	BRONZE	B-62
26 DISC PLATE NUT	STAINLESS STEEL	A-276 TYPE 316
27 BODY *	STAINLESS STEEL	A-351 GRADE CF8M
28 IDENT. PLATE	300 SERIES SST	COMMERCIAL
(METALLIC DISC VALVES)		
24A Disc	Bronze	B-62

* (BWE) ASTM A-351 GRADE CF3M

FEATURES

- Valves Cleaned for oxygen service and packaged to prevent contamination.
- Also available with Non Extended Stems

(Soft Seat Valves)

Class 150 7K2629 F.E., B.W.E. Sizes, 6" through 12"

Class 300 7K2447 F.E., B.W.E. Sizes, 6" through 12"

DIMENSIONS (Inches) Class 150

SIZE	6	8	10	12
A FACE TO FACE	16	19 1/2	24 1/2	27 1/2
B DIA. OF FLANGES	11	13 1/2	16	19
C DIA. OF RAISED FACE	8 1/2	10 5/8	12 3/4	15
D THICKNESS OF FLANGES	1	1 1/8	1 3/16	1 1/4
E CENTER TO BOTTOM	4 15/16	6 1/2	9	9 11/16
F BOTTOM OF YOKE TO TOP-OPEN	18 1/2	18 1/2	19 1/2	25 9/16
G DIA. OF HANDWHEEL	12	16	18	22
H DIA. OF STEM	1 3/8	1 1/2	2	2
J DIA. OF STUFFING BOX	2 1/64	2 17/64	3 5/64	3 1/64
K DEPT OF STUFFING BOX	2 5/8	2 3/4	3	4
L DIA. OF COLUMN	2 15/32	2 15/32	3 1/4	3 1/4
M CENTER TO TOP OF BONNET	10 1/4	11 1/2	13	15
N MAX DIA. OF YOKE ARMS	7 3/8	8 1/2	10 1/4	10 3/4
X CENTER TO BOTTOM OF YOKE (STD)	24	28	32	36
Y LIFT	2 3/16	3 15/16	4 7/32	4 3/4

(Metallic Disc Valves)

Class 150-702629 F.E., B.W.E. Sizes, 6" through 12"

Class 300-702447 T.E., S.W.E. Sizes, 6" through 12"

DIMENSIONS (Inches) Class 300

SIZE	6	8	10	12
A FACE TO FACE	17 1/2			
B DIA. OF FLANGES	12 1/2			
C DIA. OF RAISED FACE	8 1/2			
D THICKNESS OF FLANGES	1 7/16			
E CENTER TO BOTTOM	6			
F BOTTOM OF YOKE TO TOP-OPEN	18 1/2			
G DIA. OF HANDWHEEL	18			
H DIA. OF STEM	1 1/2			
J DIA. OF STUFFING BOX	2 17/64			
K DEPT OF STUFFING BOX	2 5/8			
L DIA. OF COLUMN	2 15/32			
M CENTER TO TOP OF BONNET	13			
N MAX DIA. OF YOKE ARMS	7 3/8			
X CENTER TO BOTTOM OF YOKE (STD)	24			
Y LIFT	3 5/32			

Data
On
Request

CRYOGENIC STAINLESS STEEL GLOBE VALVES

CLASS 600 BOLTED BONNET

PRESSURE/TEMPERATURE RATINGS

In accordance with ASME B16.34

See Materials and Engineering Data Section

MATERIALS (Soft Seat Valves)

DESCRIPTION	MATERIAL	ASTM Spec.
1 WHEEL NUT	STEEL	A-563 GRADE A OR B
2 HANDWHEEL	MAL. IRON	A-47 GRADE 32510
3 STEM	STAINLESS STEEL	A-582 TYPE 303
4 YOKE BUSHING	SILICON BRONZE	B-371 C69400
5 SET SCREW	STEEL	COMMERCIAL
6 GREASE FITTING	STEEL	COMMERCIAL
7 YOKE	STAINLESS STEEL	A-351 GRADE CF8M
8 GLAND EYEBOLT NUT	STAINLESS STEEL	300 SERIES
9 GLAND EYEBOLT	STAINLESS STEEL	300 SERIES
10 GLAND EYEBOLT PIN	STAINLESS STEEL	300 SERIES
11 GLAND FLANGE	STAINLESS STEEL	A-182 GR. F304
12 PACKING	PTFE	COMMERCIAL
13 EXTENSION COLUMN	STAINLESS STEEL	A-312 TYPE 304
14 BONNET	STAINLESS STEEL	A-351 GRADE CF8M
15 BONNET STUD	STAINLESS STEEL	A-193B8 TYPE 304
16 BONNET STUD NUT	STAINLESS STEEL	A-194-B TYPE 304
17 GASKET	FLEXIBLE GRAPHITE	COMMERCIAL
18 DISC LOCKNUT	SI. BR.	B-371 C69400
19 DISC HOLDER	SI. BR.	B-371 C69400
20 DISC INSERT	PCTFE	COMMERCIAL
21 DISC PLATE	BRASS	B-16
22 DISC NUT	STAINLESS STEEL	A-276 TYPE 316
23 BODY (F.E.)*	STAINLESS STEEL	A-351 GRADE CF8M
24 PACKING COLLAR	SI. BR.	B-371 C69400
25 BONNET BUSHING	SI. BR.	B-371 C69400
26 GLAND	SI. BR.	B-371 C69400
27 IDENT. PLATE	ALUMINUM	COMMERCIAL
28 IDENT. PLATE	STAINLESS STEEL	300 SERIES SST
19A Disc	Stl. Brz.	B-371, C69400

* (TE) (SWE) & (BWE) ASTM A-351, GRADE CF-3M

FEATURES

- Valves Cleaned for oxygen service and packaged to prevent contamination.
- Also available with Non Extended Stems

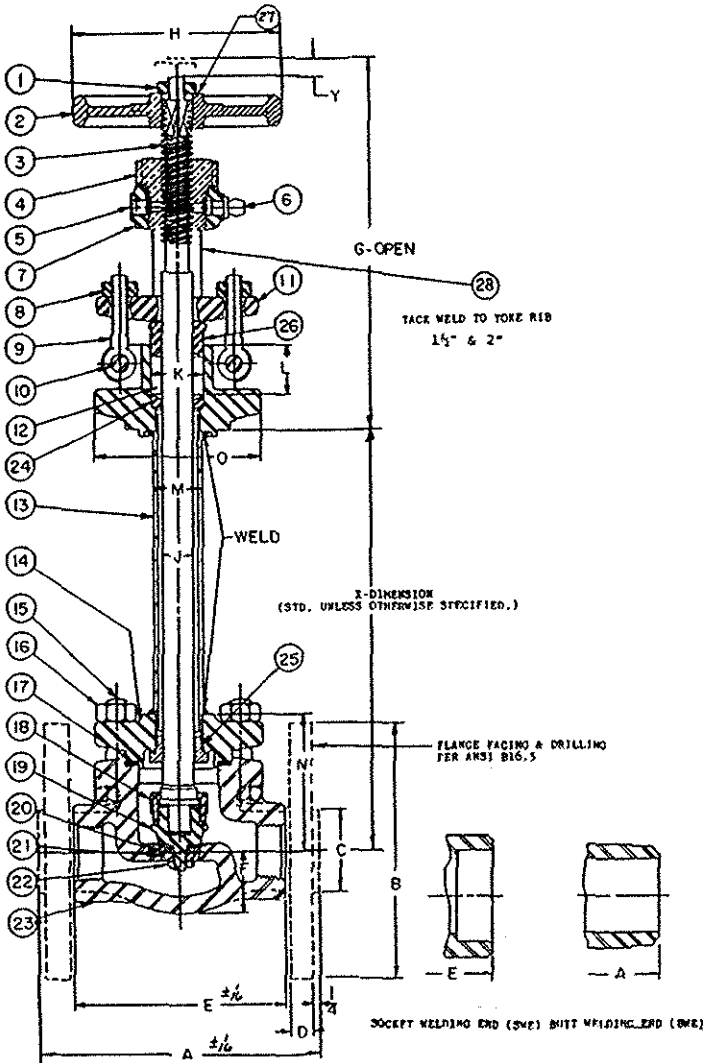

(Soft Seat Valves)
Fig. 7K1982 T.E., S.W.E.
Fig. 7K1983 F.E., B.W.E.
Sizes, 1/2" to 2"

(Metallic Disc Valves)
Fig. 701982 T.E., S.W.E.
Fig. 701983 F.E., B.W.E.
Sizes, 1/2" to 2"

DIMENSIONS (Inches)

SIZE OF VALVE	1/2	3/4	1	1 1/2	2
A FACE TO FACE	6 1/2	7 1/2	8 1/2	9 1/2	11 1/2
B DIA. OF FLANGES	3 3/4	4 5/8	4 7/8	6 1/8	6 1/2
C DIA. OF RAISED FACE	1 3/8	1 11/16	2	2 7/8	3 5/8
D THICKNESS OF FLANGES 9/16	9/16	5/8	11/16	7/8	1
E END TO END (TE & SWE)	2 7/8	3 1/4	3 3/4	5 5/8	6 1/4
F CENTER TO BOTTOM--1/2 TO 1 (T.E.)	5/8	3/4	15/16	1 5/8	2 7/32
G BOTTOM OF YOKE FLG. TO TOP-OPEN	5 1/2	5 7/8	6 9/16	8 1/8	9 1/8
H DIA. OF WHEEL	3	3 1/2	5	7	8
J DIA. OF STEM	7/16	1/2	9/16	3/4	13/16
K DIA. OF STUFFING BOX	3/4	13/16	15/16	1 1/4	1 5/16
L DEPTH OF STUFFING BOX	11/16	13/16	15/16	1 7/32	1 7/16
M DIA. OF COLUMN	11/16	27/32	27/32	1 1/16	1 5/16
N CENTER TO TOP OF BONNET	2 1/16	2 3/16	2 7/16	3 5/8	4 7/8
O YOKE FLANGE SQUARE	2 3/8	2 5/8	3	4 1/4	4 1/2
X CENTER TO BOTTOM OF YOKE (STD)	12	12	13	13	14
Y LIFT	7/16	1/2	1/2	3/4	13/16

CRYOGENIC STAINLESS STEEL SWING CHECK VALVES

CLASS 150-200-300

BOLTED FLANGED CAP

PRESSURE/TEMPERATURE RATINGS

In accordance with ASME B16.34

See Materials and Engineering Data Section

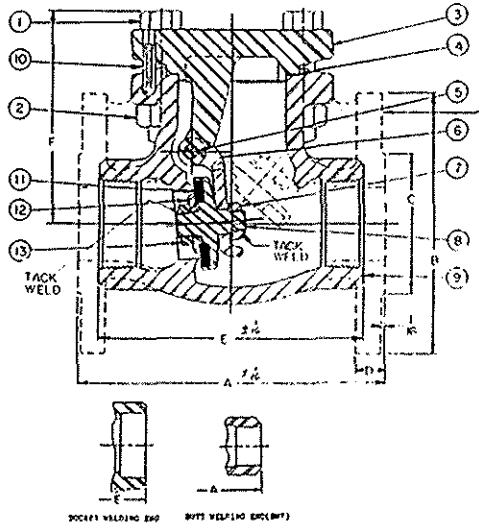

MATERIALS (Soft Seat Valves)

DESCRIPTION	MATERIAL	ASTM Spec.
1 CAP BOLT	STAINLESS STEEL	A193 GRADE B8
2 CAP BOLT NUT	STAINLESS STEEL	A194 GRADE 8
3 CAP	STAINLESS STEEL	A351 GRADE CF8M
4 GASKET	FLEXIBLE GRAPHITE	COMMERCIAL
5 CARRIER PIN	STAINLESS STEEL	A276 TYPE 316
6 CARRIER	STAINLESS STEEL	A351 GRADE CF8M
7 DISC LOCKNUT	STAINLESS STEEL	A276 TYPE 316
8 DISC HOLDER	STAINLESS STEEL	A276 TYPE 316
9 BODY*	STAINLESS STEEL	A351 GRADE CF8M
10 LOCATING PIN	STAINLESS STEEL	COMMERCIAL
11 DISC	PCTFE	COMMERCIAL
12 DISC PLATE	STAINLESS STEEL	A276 TYPE 316
13 DISC NUT	STAINLESS STEEL	A276 TYPE 316
	(METALLIC DISC VALVES)	
11A Disc	Stainless Steel	A351 Gr. CF8M

*(T.E.), (W.E.) ASTM A-351 CF3M

FEATURES

*Valves Cleaned for oxygen service and packaged to prevent contamination.

(Soft Seat Valves)

Class 200 Fig. 7K2341 T.E., S.W.E. Sizes, 3/8" to 2"
 Class 150 Fig. 7K2342 F.E., B.W.E. Sizes, 1/2" to 8"
 Class 300 Fig. 7K2345 T.E., S.W.E. Sizes, 3/8" to 2"
 Class 300 Fig. 7K2346 F.E., B.W.E. Sizes, 1/2" to 6"

(Metallic Disc Valves)

Class 200 Fig. 702341 T.E., S.W.E. Sizes, 3/8" to 2"
 Class 150 Fig. 702342 F.E., B.W.E. Sizes, 1/2" to 8"
 Class 300 Fig. 702345 T.E., S.W.E. Sizes, 3/8" to 2"
 Class 300 Fig. 702346 F.E., B.W.E. Sizes, 1/2" to 6"

DIMENSIONS (Inches) Class 150-200

SIZE OF VALVE	3/8	1/2	3/4	1	1 1/2	2	3	4	6	8
A FACE TO FACE (FE)&(BWE)		4 1/4	4 5/8	5	6 3/8	8	9 3/4	11 1/4	14	19 1/2
B DIAMETER OF FLANGES		3 1/4	3 7/8	4 1/4	5	6	7 1/4	9	11	13 1/2
C DIAMETER OF RAISED FACE		1 3/8	1 11/16	2	2 7/8	3 5/8	5	6 3/16	8 1/2	10 5/8
D THICKNESS OF FLANGES		3/8	13/32	7/16	9/16	5/8	3/4	15/16	1	1 1/8
E END TO END (TE)&(SWE)	2 1/4	2 3/4	3 1/4	4	5 1/4	6				
F CENTER TO TOP OF BOLT (FE)&(SWE)	2 5/32	2 5/32	3	3 3/8	4 1/16	4 9/16				
G CENTER TO TOP OF BOLT (FE)&(BWE)	2 5/32	2 5/32	3	3 3/8	4 1/16	4 9/16	5 9/16	6 1/8	7 13/16	9 5/8

DIMENSIONS (Inches) Class 300

SIZE OF VALVE	3/8	1/2	3/4	1	1 1/2	2	3	4	6
A FACE TO FACE (FE)&(BWE)		6	7	8 1/2	9 1/2	10 3/4	12 1/4	14	17 1/2
B DIAMETER OF FLANGE		3 3/4	4 5/8	4 7/8	6 1/8	6 3/4	8 1/4	10	12 1/2
C DIAMETER OF RAISED FACE		1 3/8	1 11/16	2	2 7/8	3 5/8	5	6 3/16	8 1/2
D THICKNESS OF FLANGE		9/16	5/8	11/16	13/16	7/8	1 1/8	1 1/4	1 7/16
E END TO END (TE)&(SWE)	2 3/4	2 3/4	3 3/4	4	5 1/4	6			
F CENTER TO TOP OF BOLT (FE)&(SWE)	2 3/32	2 3/32	2 15/16	3 5/16	3 15/16	4 1/4			
G CENTER TO TOP OF BOLT (FE)&(BWE)	2 9/16	3 5/16	3 11/16	3 15/16	4 1/4	5 1/4	6 1/16	6 3/8	

CRYOGENIC STAINLESS STEEL SWING CHECK VALVES

CLASS 150 BOLTED CAP

PRESSURE/TEMPERATURE RATINGS

In accordance with ASME B16.34

See Materials and Engineering Data Section

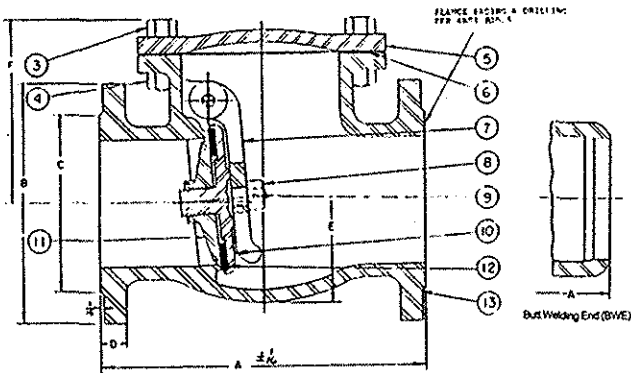
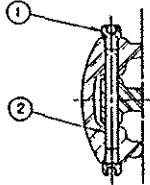

MATERIALS (Soft Seat Valves)

DESCRIPTION	MATERIAL	ASTM Spec.
1 PLUG	STAINLESS STEEL	A-276 TYPE 316
2 CARRIER PIN	STAINLESS STEEL	A-276 TYPE 316
3 CAP BOLT	STAINLESS STEEL	A193 GRADE B8
4 CAP BOLT NUT	STAINLESS STEEL	A-194 GRADE 8
5 CAP	STAINLESS STEEL	A-351 GRADE CF8M
6 GASKET	FLEXIBLE GRAPHITE	COMMERCIAL
7 CARRIER	STAINLESS STEEL	A-351 GRADE CF8M
8 CARRIER DISC NUT	STAINLESS STEEL	A-276 TYPE 316
9 CARRIER DISC NUT PIN	STAINLESS STEEL	A-276 TYPE 316
10 DISC HOLDER	STAINLESS STEEL	A-351 GRADE CF8M
11 DISC NUT	STAINLESS STEEL	A351 GRADE CF8M
12 DISC	PCTFE	COMMERCIAL
13 BODY*	STAINLESS STEEL	A-351 GRADE CF8M

*MATERIAL (B.W.E.) ASTM A-351 GRADE CF8M

SPECIFICATIONS

- Flanged valves have end flanges in accordance with ANSI B16.5
- Face-to-face dimensions conform to ANSI B16.10

FEATURES

- Valves cleaned for oxygen service and packaged to prevent contamination

(Soft Seat Valves)
Fig. 7K2633 F.E., B.W.E.
Sizes, 10" and 12"

(Metallic Disc Valves)
Fig. 702633 F.E., B.W.E.
Sizes, 10" and 12"

DIMENSIONS (Inches)

SIZE OF VALVE	10	12
A FACE TO FACE (F.E.)	24 1/2	27 1/2
B DIA. OF FLANGES	16	19
C DIA. OF RAISED FACE	12 3/4	15
D THICKNESS OF FLANGES	1 3/16	1 1/4
E CENTER TO BOTTOM	8 7/16	9 5/8
F CENTER TO TOP	14	14 1/2

CRYOGENIC VALVES

-COMPLETE TANK FILL ASSEMBLY-

*The Better Way to keep
Cryogenic Tank Fill
under Control*

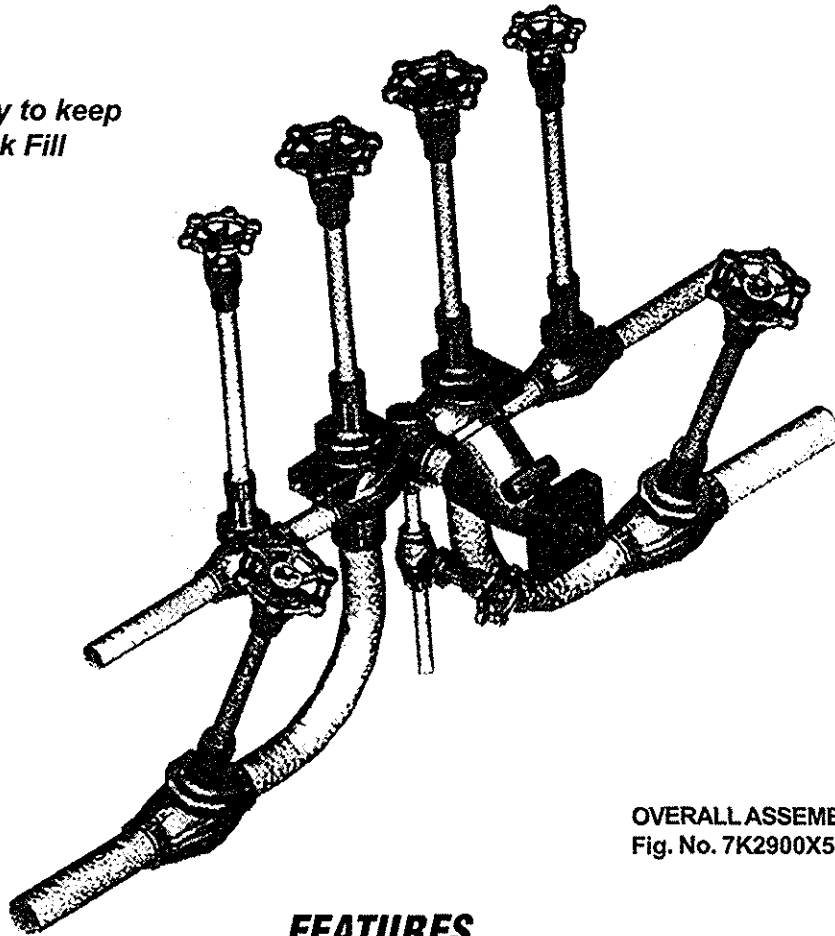

OVERALL ASSEMBLY
Fig. No. 7K2900X52

FEATURES

- **ELIMINATES INDIVIDUAL
VALVE REPLACEMENT**
- **FIELD MAINTENANCE
NO LONGER A PROBLEM**
- **COST REDUCTION
LESS DOWN TIME
ELIMINATES A MINIMUM
OF 20 CONNECTIONS**
- **SIMPLIFICATION**
- **COMPUTER TECHNOLOGY
DESIGNED WITH
CUSTOMER INPUT**
- **COMPLETE ASSEMBLY 8 VALVES
ALSO AVAILABLE IN 4 OR 6 VALVE
CONFIGURATIONS TO FIT
CUSTOMER'S REQUIREMENTS**

**STRIVING FOR
INDUSTRY STANDARDIZATION**

ADAPTO-GEAR ACTUATORS

Most Powell Multi-Turn Valves can be supplied with Adapto Gears. For installed Powell valves, Gear Units with adaptor parts are available. Adapto Gear units are also available separately for any Multi-Turn valve application.

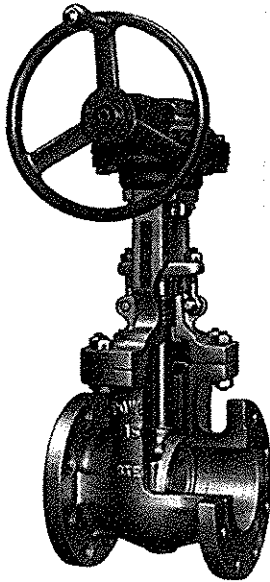

**Class 150 Cast Steel Gate Valve
with Adapto Gear Actuator**

Available Handwheel Sizes for Adapto
Gear Actuators

Size	Handwheels
AA	18"
B	24"
C	24"

Typical Adapto-Gear Installation:

- Remove the handwheel.
- Remove bolts from the yoke, mount the adaptor, replace bolts and tighten.
- Install the sleeve and key on stem bushing.
- Mount gear operator on adaptor and bolt together.
- Conversion is completed.

For installed valves, adaptors are provided so that new stem bushings or bonnets are not necessary. Field conversion can be completed without removing the valve from service.

Powell Adapto Gear Actuators are fully enclosed light weight, maintenance free Bevel Gear Units for valves which require gearing to facilitate operation. The actuators mount quickly and easily as installation does not require special complicated parts. The manual valve actuators, Type AA, B and C, have been designed for simplicity, high efficiency and ease of adaptability to make them ideal for use on both small and large valves. The input shaft is mounted on anti-friction bearings and the bevel gear drive sleeve is supported by an integral bearing arrangement. The actuator does not take any of the valve stem thrust since the thrust is absorbed in the valve stem bushing.

- Anti-friction bearings permits ease of operation.
- Housing protects gears from dirt, dust, foreign materials. Also a safety factor; protects the operating personnel.
- Housing has provision for a plug or pipe stem protector when required. Sealed housing retains the lubricant and protects the moving parts.
- Adaptors for air wrench operation can be supplied on order.

MODEL AA-18 ACTUATOR

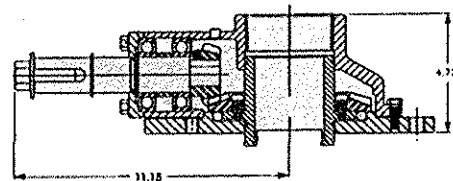

MODEL B-24 ACTUATOR

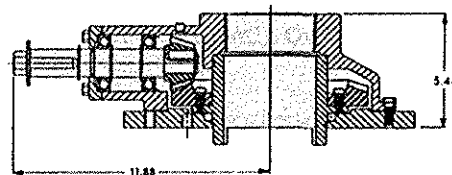

MODEL C-24 ACTUATOR

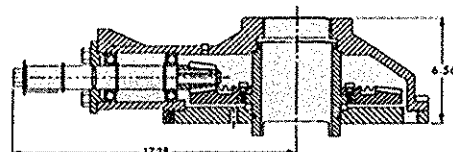

MOTOR-ACTUATED VALVES

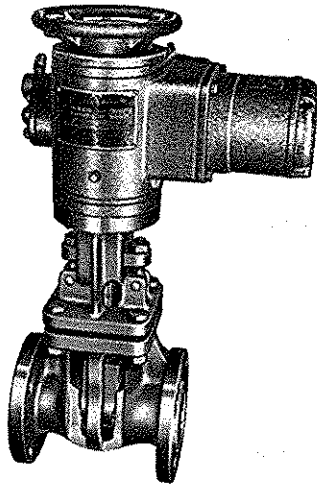

Flanged End. O.S.&Y. Gate Valve with Electric Motor Actuator

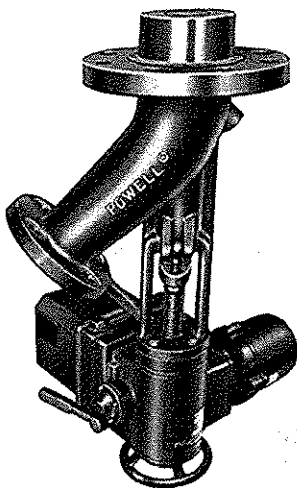

Flush Bottom Tank Valve with Electric Motor Actuator

Most Powell Valves can be furnished with electric motor actuators.

This type of equipment gives fast, safe, efficient operation of any valve by means of a pushbutton from a remote point or automatically from a limit switch, pressure switch or other similar device. To enable us to quote accurately on Motor Actuated Valves, we will need the following complete information:

- A. Valve Size and Figure Number

- B. Media

- C. Media Pressure and Temperature

- D. Differential Pressure against which valve must open and close

- E. Opening or Closing Time Requirements. Unless specified-Gate Valve Stem Speed 12" per minute (approx.) and Globe Valve Stem Speed 4" per minute (approx.).

- F. Voltage, Frequency and Number of Phases

- G. Special Features (eg. Control Station Requirements, Special Enclosure Type, etc.)

HYDRAULIC or PNEUMATIC ACTUATED VALVES

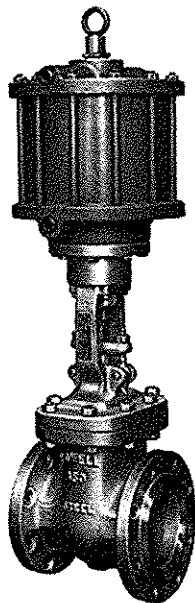

Flanged End
Gate Valve
With Air Cylinder Actuator

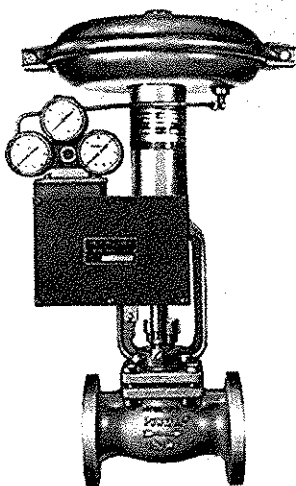

Flanged End Diaphragm
Actuated Globe Valve
With position indicators

Most Powell Valves can be equipped with Hydraulic or Pneumatic Actuators for automatic remote opening and closing. When ordering such valves, the following information must be given:

- A. Valve Size and Figure Number
- B. Media
- C. Media Pressure and Temperature
- D. Differential Pressure against which valve must open and close
- E. Opening or Closing Time Requirements
- F. Actuator Media Pressure - Min./Max.
- G. Failure Position (Open, Close, or as is)
- H. Special Features (eg. Limit Switches, Manual Override, etc.)
- I. Environmental Temperature Range - Max. / Min.

ENGINEERING DATA INDEX

	PAGE
VALVE STANDARDS AND RELATED INFORMATION	138
VALVE PRESSURE/TEMPERATURE RATINGS	139-150
CHEMICAL AND PHYSICAL PROPERTIES	151, 152
TRIM DESCRIPTIONS	153
DIMENSIONS OF WROUGHT STEEL PIPE AND WELD END CONFIGURATION	154-159
FLANGE DIMENSIONS	160-166
METHOD OF DESIGNATING LOCATION OF AUXILIARY CONNECTIONS	167
FLOW DATA	168, 169
CONVERSION DATA	170-172

NOTE: DATA PROVIDED IN THIS SECTION IS FOR REFERENCE PURPOSES AND IS SUBJECT TO CHANGE. CONSULT CURRENT STANDARDS AND SPECIFICATIONS FOR THE LATEST DATA AND FOR SPECIFIC DETAILS WHICH MAY BE BEYOND THE SCOPE OF THIS CATALOG.

COPYRIGHT INFORMATION

SOME DATA, TABLES AND FIGURES HAVE BEEN EXTRACTED IN WHOLE OR IN PART WITH PERMISSION OF THE PUBLISHERS AS FOLLOWS:

ASME: B16.5, B16.10, B16.24, B16.25, B16.34 AND B16.47
ASTM: A216, A217, A351, A352 AND A494
API: API 600

VALVE STANDARDS AND RELATED INFORMATION

1. Steel and Corrosion Resistant Designs

- (A) ASME B16.34-Valves-Flanged, Threaded and Welding End

This is the basic ASME valve standard for steel and corrosion resistant alloys. This standard contains requirements such as minimum shell wall thickness, pressure/temperature ratings, and pressure testing requirements.

- (B) API Standard 600 - Steel Gate Valve Flanged and Butt Welding Ends, Bolted and Pressure Seal Bonnets

This is the basic API valve standard and contains wall thicknesses that are heavier than ASME B16.34 for bolted bonnet valves. This standard refers to B16.34 for pressure/temperature ratings. Requirements for two styles of pressure seal are included as follows: Style A (B16.34 Wall Thicknesses) and Style B (API 600 Wall Thicknesses).

- (C) API Standard 598 - Valve Inspection and Testing.

This standard is referenced by API 600 and contains minimum inspection and pressure test requirements.

- (D) ASME B16.5 - Pipe Flanges and Flange Fittings.

- (E) ASME B16.10 - Face to Face and End to End Dimensions of Valves.

- (F) ASME B16.25 - Buttwelding Ends

- (G) MSS SP-61 - Pressure Testing of Steel Valves

2. Bronze and Iron Valves

- (A) MSS SP-80 - Bronze Gate, Globe, Angle and Check Valves.

- (B) MSS SP-70 - Cast Iron Gate Valves, Flanged and Threaded Ends.

- (C) MSS SP-71 - Cast Iron Check Valves, Flanged and Threaded Ends

- (D) MSS SP-85 - Cast Iron Globe and Angle Valves, Flanged and Threaded Ends.

3. Powell Publications and Miscellaneous Information

The following manuals contain valve selection, storage, installation, operation, and maintenance information. Note that prior to any installation or maintenance, appropriate precautions must be followed. For example, all pressure must be relieved from the valve and affected piping prior to servicing and proper protective clothing and equipment must be worn. See the following publications for more complete information.

- (A) Handbook of Valve Information
This publication contains general information for all Powell valves.

- (B) Pressure Seal Valves - Instruction Manual
This publication contains information specific to Pressure Seal Valves.

VALVE PRESSURE/TEMPERATURE RATINGS

THE FOLLOWING TABLES CONTAIN PRESSURE/TEMPERATURE RATINGS FOR THE MATERIALS LISTED BELOW. SEE NOTES IN THE TABLE FOR TEMPERATURE AND OTHER MATERIAL LIMITATIONS. NOTE THAT CERTAIN VALVE PACKING OR SOFT SEATED MATERIALS MAY HAVE OTHER TEMPERATURE LIMITATIONS. VALVES ARE NOT TO BE SUBJECTED TO CONDITIONS THAT EXCEED THE RATINGS AND LIMITATIONS GIVEN IN THESE TABLES.

DESCRIPTION	NOMINAL DESIGNATION	PRESSURE/TEMPERATURE RATINGS	CASTING MATERIAL	FORGING MATERIAL
STEEL	CARBON	TABLE 1	A216-WCB	A105
ALLOY STEEL	1-1/4 Cr-1/2Mo	TABLE 2	A217-WC6	A182-F11
	2-1/4 Cr-1 Mo	TABLE 3	A217-WC9	A182-F22
	5 Cr-1/2 Mo	TABLE 4	A217-C5	A182-F5a
	9 Cr-1/2 Mo	TABLE 5	A217-C12	A182-F9
	9 Cr-1 Mo-V	TABLE 6	A217-C12A	A182-F91
STAINLESS STEEL	18 Cr-8Ni	TABLE 7	A351-CF3	A182-F304L
		TABLE 7	A351-CF8	A182-F304
STAINLESS STEEL	18 Cr-9 Ni-2 Mo	TABLE 8	A351-CF3M	A182-F316L
		TABLE 8	A351-CF8M	A182-F316
ALLOY 20	29 Ni-20.5Cr 3.5 Cu-2.5 Mo	TABLE 9	A351-CN7M	
BRONZE		TABLE 10	B61/B62	
CAST IRON		TABLE 11	A126-B	

Note: Forging Specification provided for reference purposes only

PRESSURE/TEMPERATURE RATINGS

TABLE 1

ASTM A216 Grade WCB

Upon prolonged exposure to temperatures above 800° F, the carbide phase of steel may be converted to graphite.
Permissible, but not recommended for prolonged use above 800° F.

STANDARD CLASS

Working Pressures by Classes, psig								
Temperature, °F	150	300	400	600	900	1500	2500	4500
-20 to 100	285	740	990	1,480	2,220	3,705	6,170	11,110
200	260	675	900	1,350	2,025	3,375	5,625	10,120
300	230	655	875	1,315	1,970	3,280	5,470	9,845
400	200	635	845	1,270	1,900	3,170	5,280	9,505
500	170	600	800	1,200	1,795	2,995	4,990	8,980
600	140	550	730	1,095	1,640	2,735	4,560	8,210
650	125	535	715	1,075	1,610	2,685	4,475	8,055
700	110	535	710	1,065	1,600	2,665	4,440	7,990
750	95	505	670	1,010	1,510	2,520	4,200	7,560
800	80	410	550	825	1,235	2,060	3,430	6,170

SPECIAL CLASS

Working Pressures by Classes, psig								
Temperature, °F	150	300	400	600	900	1500	2500	4500
-20 to 100	290	750	1,000	1,500	2,250	3,750	6,250	11,250
200	290	750	1,000	1,500	2,250	3,750	6,250	11,250
300	290	750	1,000	1,500	2,250	3,750	6,250	11,250
400	290	750	1,000	1,500	2,250	3,750	6,250	11,250
500	290	750	1,000	1,500	2,250	3,750	6,250	11,250
600	275	715	950	1,425	2,140	3,565	5,940	10,690
650	270	700	935	1,400	2,100	3,495	5,825	10,485
700	265	695	925	1,390	2,080	3,470	5,780	10,405
750	240	630	840	1,260	1,890	3,150	5,250	9,450
800	200	515	685	1,030	1,545	2,570	4,285	7,715

NOTE: Special Class Ratings apply to Threaded and Weld End Valves only and require upgrading per paragraph 8 of ASME B16.34

PRESSURE/TEMPERATURE RATINGS

TABLE 2

ASTM A217 Grade WC6

Use normalized and tempered material only. Not to be used over 1100° F.

STANDARD CLASS

Working Pressures by Classes, psig								
Temperature, °F	150	300	400	600	900	1500	2500	4500
-20 to 100	290	750	1,000	1,500	2,250	3,750	6,250	11,250
200	260	750	1,000	1,500	2,250	3,750	6,250	11,250
300	230	720	965	1,445	2,165	3,610	6,015	10,830
400	200	695	925	1,385	2,080	3,465	5,775	10,400
500	170	665	885	1,330	1,995	3,325	5,540	9,965
600	140	605	805	1,210	1,815	3,025	5,040	9,070
650	125	590	785	1,175	1,765	2,940	4,905	8,825
700	110	570	755	1,135	1,705	2,840	4,730	8,515
750	95	530	710	1,065	1,595	2,660	4,430	7,970
800	80	510	675	1,015	1,525	2,540	4,230	7,610
850	65	485	650	975	1,460	2,435	4,060	7,305
900	50	450	600	900	1,350	2,245	3,745	6,740
950	35	320	425	640	955	1,595	2,655	4,785
1000	20	215	290	430	650	1,080	1,800	3,240
1050	20(1)	145	190	290	430	720	1,200	2,160
1100	20(1)	95	130	190	290	480	800	1,440

NOTE: (1) For welding end valves only. Flanged end ratings terminate at 1000° F.

SPECIAL CLASS

Working Pressures by Classes, psig								
Temperature, °F	150	300	400	600	900	1500	2500	4500
-20 to 100	290	750	1,000	1,500	2,250	3,750	6,250	11,250
200	290	750	1,000	1,500	2,250	3,750	6,250	11,250
300	290	750	1,000	1,500	2,250	3,750	6,250	11,250
400	290	750	1,000	1,500	2,250	3,750	6,250	11,250
500	290	750	1,000	1,500	2,250	3,750	6,250	11,250
600	290	750	1,000	1,500	2,250	3,750	6,250	11,250
650	290	750	1,000	1,500	2,250	3,750	6,250	11,250
700	280	735	980	1,465	2,200	3,665	6,110	10,995
750	280	730	970	1,460	2,185	3,645	6,070	10,930
800	275	720	960	1,440	2,160	3,600	6,000	10,800
850	260	680	905	1,355	2,030	3,385	5,645	10,160
900	225	585	785	1,175	1,760	2,935	4,895	8,805
950	155	400	530	795	1,195	1,995	3,320	5,980
1000	105	270	360	540	810	1,350	2,250	4,050
1050	70	180	240	360	540	900	1,500	2,700
1100	45	120	160	240	360	600	1,000	1,800

NOTE: Special Class Ratings apply to Threaded and Weld End Valves only and require upgrading per paragraph 8 of ASME B16.34

PRESSURE/TEMPERATURE RATINGS

TABLE 3

ASTM A217 Grade WC9

Use normalized and tempered material only. Not to be used over 1100° F.

STANDARD CLASS

Working Pressures by Classes, psig								
Temperature, °F	150	300	400	600	900	1500	2500	4500
-20 to 100	290	750	1,000	1,500	2,250	3,750	6,250	11,250
200	260	750	1,000	1,500	2,250	3,750	6,250	11,250
300	230	730	970	1,455	2,185	3,640	6,070	10,925
400	200	705	940	1,410	2,115	3,530	5,880	10,585
500	170	665	885	1,330	1,995	3,325	5,540	9,965
600	140	605	805	1,210	1,815	3,025	5,040	9,070
650	125	590	785	1,175	1,765	2,940	4,905	8,825
700	110	570	755	1,135	1,705	2,840	4,730	8,515
750	95	530	710	1,065	1,595	2,660	4,430	7,970
800	80	510	675	1,015	1,525	2,540	4,230	7,610
850	65	485	650	975	1,460	2,435	4,060	7,305
900	50	450	600	900	1,350	2,245	3,745	6,740
950	35	375	505	755	1,130	1,885	3,145	5,665
1000	20	260	345	520	780	1,305	2,170	3,910
1050	20(1)	175	235	350	525	875	1,455	2,625
1100	20(1)	110	145	220	330	550	915	1,645

NOTE: (1) For welding end valves only. Flanged end ratings terminate at 1000° F.

SPECIAL CLASS

Working Pressures by Classes, psig								
Temperature, °F	150	300	400	600	900	1500	2500	4500
-20 to 100	290	750	1,000	1,500	2,250	3,750	6,250	11,250
200	290	750	1,000	1,500	2,250	3,750	6,250	11,250
300	285	740	990	1,485	2,225	3,705	6,180	11,120
400	280	725	965	1,450	2,175	3,620	6,035	10,865
500	275	720	960	1,440	2,160	3,600	6,000	10,800
600	275	720	960	1,440	2,160	3,600	6,000	10,800
650	275	715	955	1,430	2,145	3,580	5,965	10,735
700	275	710	955	1,425	2,135	3,555	5,930	10,670
750	265	690	920	1,380	2,070	3,450	5,750	10,350
800	260	675	895	1,345	2,020	3,365	5,605	10,095
850	245	645	855	1,285	1,930	3,215	5,355	9,645
900	230	600	800	1,200	1,800	3,000	5,000	9,000
950	180	470	630	945	1,415	2,355	3,930	7,07
1000	125	325	435	650	975	1,630	2,715	4,885
1050	85	220	290	435	655	1,095	1,820	3,280
1100	55	135	185	275	410	685	1,145	2,055

NOTE: Special Class Ratings apply to Threaded and Weld End Valves only and require upgrading per paragraph 8 of ASME B16.34

PRESSURE/TEMPERATURE RATINGS

TABLE 4

ASTM A217 Grade C5

Use normalized and tempered material only

STANDARD CLASS

Working Pressures by Classes, psig								
Temperature, °F	150	300	400	600	900	1500	2500	4500
-20 to 100	290	750	1,000	1,500	2,250	3,750	6,250	11,250
200	260	745	995	1,490	2,235	3,725	6,205	11,170
300	230	715	955	1,430	2,150	3,580	5,965	10,740
400	200	705	940	1,410	2,115	3,520	5,880	10,585
500	170	665	885	1,330	1,995	3,325	5,540	9,965
600	140	605	805	1,210	1,815	3,025	5,040	9,070
650	125	590	785	1,175	1,765	2,940	4,905	8,825
700	110	570	755	1,135	1,705	2,840	4,730	8,515
750	95	530	705	1,055	1,585	2,640	4,400	7,920
800	80	510	675	1,015	1,525	2,540	4,230	7,610
850	65	485	645	965	1,450	2,415	4,030	7,250
900	50	370	495	740	1,110	1,850	3,085	5,555
950	35	275	365	550	825	1,370	2,285	4,115
1000	20	200	265	400	595	995	1,655	2,985
1050	20(1)	145	190	290	430	720	1,200	2,160
1100	20(1)	100	135	200	300	495	830	1,490
1150	20(1)	60	80	125	185	310	515	925
1200	15(1)	35	45	70	105	170	285	515

NOTE: (1) For welding end valves only. Flanged end ratings terminate at 1000° F.

SPECIAL CLASS

Working Pressures by Classes, psig								
Temperature, °F	150	300	400	600	900	1500	2500	4500
-20 to 100	290	750	1,000	1,500	2,250	3,750	6,250	11,250
200	290	750	1,000	1,500	2,250	3,750	6,250	11,250
300	280	730	970	1,455	2,185	3,645	6,070	10,930
400	275	720	960	1,440	2,160	3,600	6,000	10,800
500	275	720	960	1,440	2,160	3,600	6,000	10,800
600	270	705	945	1,415	2,120	3,535	5,895	10,605
650	270	700	930	1,395	2,095	3,495	5,820	10,480
700	265	685	915	1,370	2,055	3,430	5,715	10,285
750	255	660	880	1,320	1,980	3,300	5,500	9,900
800	245	640	850	1,275	1,915	3,195	5,320	9,580
850	230	605	805	1,210	1,815	3,020	5,035	9,065
900	175	465	615	925	1,390	2,315	3,855	6,945
950	130	345	455	685	1,030	1,715	2,855	5,145
1000	95	250	330	495	745	1,245	2,070	3,730
1050	70	180	240	360	540	900	1,500	2,700
1100	50	125	165	250	375	620	1,035	1,865
1150	30	75	105	155	230	385	645	1,155
1200	15	45	55	85	130	215	355	645

NOTE: Special Class Ratings apply to Threaded and Weld End Valves only and require upgrading per paragraph 8 of ASME B16.34

PRESSURE/TEMPERATURE RATINGS

TABLE 5

ASTM A217 Grade C12
Use normalized and tempered material only.

STANDARD CLASS

Working Pressures by Classes, psig								
Temperature, °F	150	300	400	600	900	1500	2500	4500
-20 to 100	290	750	1,000	1,500	2,250	3,750	6,250	11,250
200	260	750	1,000	1,500	2,250	3,750	6,250	11,250
300	230	730	970	1,455	2,185	3,640	6,070	10,925
400	200	705	940	1,410	2,115	3,530	5,880	10,585
500	170	665	885	1,330	1,995	3,325	5,540	9,965
600	140	605	805	1,210	1,815	3,025	5,040	9,070
650	125	590	785	1,175	1,765	2,940	4,905	8,825
700	110	570	755	1,135	1,705	2,840	4,730	8,515
750	95	530	710	1,065	1,595	2,660	4,430	7,970
800	80	510	675	1,015	1,525	2,540	4,230	7,610
850	65	485	650	975	1,460	2,435	4,060	7,305
900	50	450	600	900	1,350	2,245	3,745	6,740
950	35	375	505	755	1,130	1,885	3,145	5,655
1000	20	255	340	505	760	1,270	2,115	3,805
1050	20(1)	170	230	345	515	855	1,430	2,570
1100	20(1)	115	150	225	340	565	945	1,695
1150	20(1)	75	100	150	225	375	630	1,130
1200	20(1)	50	70	105	155	255	430	770

NOTE: (1) For welding end valves only. Flanged end ratings terminate at 1000° F.

SPECIAL CLASS

Working Pressures by Classes, psig								
Temperature, °F	150	300	400	600	900	1500	2500	4500
-20 to 100	290	750	1,000	1,500	2,250	3,750	6,250	11,250
200	290	750	1,000	1,500	2,250	3,750	6,250	11,250
300	290	750	1,000	1,500	2,250	3,750	6,250	11,250
400	290	750	1,000	1,500	2,250	3,750	6,250	11,250
500	290	750	1,000	1,500	2,250	3,750	6,250	11,250
600	290	750	1,000	1,500	2,250	3,750	6,250	11,250
650	290	750	1,000	1,500	2,250	3,750	6,250	11,250
700	280	735	980	1,465	2,200	3,665	6,110	10,995
750	280	730	970	1,460	2,185	3,645	6,070	10,930
800	275	720	960	1,440	2,160	3,600	6,000	10,800
850	260	680	905	1,355	2,030	3,385	5,645	10,160
900	230	600	800	1,200	1,800	3,000	5,000	9,000
950	180	470	630	945	1,415	2,355	3,930	7,070
1000	120	315	425	635	950	1,585	2,645	4,755
1050	80	215	285	430	645	1,070	1,785	3,215
1100	55	140	190	285	425	710	1,180	2,120
1150	35	95	125	190	285	470	785	1,415
1200	25	65	85	130	195	320	535	965

NOTE: Special Class Ratings apply to Threaded and Weld End Valves only and require upgrading per paragraph 8 of ASME B16.34

PRESSURE/TEMPERATURE RATINGS

TABLE 6

ASTM A217 Grade C12A STANDARD CLASS

Working Pressures by Classes, psig								
Temperature, °F	150	300	400	600	900	1500	2500	4500
-20 to 100	290	750	1,000	1,500	2,250	3,750	6,250	11,250
200	260	750	1,000	1,500	2,250	3,750	6,250	11,250
300	230	730	970	1,455	2,185	3,640	6,070	10,925
400	200	705	940	1,410	2,115	3,530	5,880	10,585
500	170	665	885	1,330	1,995	3,325	5,540	9,965
600	140	605	805	1,210	1,815	3,025	5,040	9,070
650	125	590	785	1,175	1,765	2,940	4,905	8,825
700	110	570	755	1,135	1,705	2,840	4,730	8,515
750	95	530	710	1,065	1,595	2,660	4,430	7,970
800	80	510	675	1,015	1,525	2,540	4,230	7,610
850	65	485	650	975	1,460	2,435	4,060	7,305
900	50	450	600	900	1,350	2,245	3,745	6,740
950	35	385	515	775	1,160	1,930	3,220	5,795
1000	20	365	485	725	1,090	1,820	3,030	5,450
1050	20(1)	360	480	720	1,080	1,800	3,000	5,400
1100	20(1)	300	400	605	905	1,510	2,515	4,525
1150	20(1)	225	295	445	670	1,115	1,855	3,345
1200	20(1)	145	190	290	430	720	1,200	2,160

NOTE: (1) For welding end valves only. Flanged end ratings terminate at 1000° F.

SPECIAL CLASS

Working Pressures by Classes, psig								
Temperature, °F	150	300	400	600	900	1500	2500	4500
-20 to 100	290	750	1,000	1,500	2,250	3,750	6,250	11,250
200	290	750	1,000	1,500	2,250	3,750	6,250	11,250
300	290	750	1,000	1,500	2,250	3,750	6,250	11,250
400	290	750	1,000	1,500	2,250	3,750	6,250	11,250
500	290	750	1,000	1,500	2,250	3,750	6,250	11,250
600	290	750	1,000	1,500	2,250	3,750	6,250	11,250
650	290	750	1,000	1,500	2,250	3,750	6,250	11,250
700	280	735	980	1,465	2,200	3,665	6,110	10,995
750	280	730	970	1,460	2,185	3,645	6,070	10,930
800	275	720	960	1,440	2,160	3,600	6,000	10,800
850	260	680	905	1,355	2,030	3,385	5,645	10,160
900	230	600	800	1,200	1,800	3,000	5,000	9,000
950	180	470	630	945	1,415	2,360	3,930	7,070
1000	160	420	560	840	1,260	2,105	3,505	6,310
1050	160	420	560	840	1,260	2,105	3,505	6,310
1100	145	375	505	755	1,130	1,885	3,145	5,655
1150	105	280	370	555	835	1,395	2,320	4,180
1200	70	180	240	360	540	900	1,500	2,700

NOTE: Special Class Ratings apply to Threaded and Weld End Valves only and require upgrading per paragraph 8 of ASME B16.34

PRESSURE/TEMPERATURE RATINGS

TABLE 7

ASTM A351 Grade CF3(a) ASTM A351 Grade CF8(b)

(a) Not to be used over 800° F

(b) At temperatures over 1000° F, use only when the carbon content is 0.04% or higher. This requirement must be specified by customer when applicable.

STANDARD CLASS

Working Pressures by Classes, psig								
Temperature, °F	150	300	400	600	900	1500	2500	4500
-20 to 100	275	720	960	1,440	2,160	3,600	6,000	10,800
200	230	600	800	1,200	1,800	3,000	5,000	9,000
300	205	540	720	1,080	1,620	2,700	4,500	8,100
400	190	495	660	995	1,490	2,485	4,140	7,450
500	170	465	620	930	1,395	2,330	3,880	6,985
600	140	435	580	875	1,310	2,185	3,640	6,550
650	125	430	575	860	1,290	2,150	3,580	6,445
700	110	425	565	850	1,275	2,125	3,540	6,370
750	95	415	555	830	1,245	2,075	3,460	6,230
800	80	405	540	805	1,210	2,015	3,360	6,050
850	65	395	530	790	1,190	1,980	3,300	5,940
900	50	390	520	780	1,165	1,945	3,240	5,830
950	35	380	510	765	1,145	1,910	3,180	5,725
1000	20	320	430	640	965	1,605	2,675	4,815
1050	20(1)	310	410	615	925	1,545	2,570	4,630
1100	20(1)	255	345	515	770	1,285	2,145	3,855
1150	20(1)	200	265	400	595	995	1,655	2,985
1200	20(1)	155	205	310	465	770	1,285	2,315
1250	20(1)	115	150	225	340	565	945	1,695
1300	20(1)	85	115	170	255	430	715	1,285
1350	20(1)	60	80	125	185	310	515	925
1400	20(1)	50	65	95	145	240	400	720
1450	15(1)	35	45	70	105	170	285	515
1500	10(1)	25	35	55	80	135	230	410

NOTE: (1) For welding end valves only. Flanged end ratings terminate at 1000° F.

SPECIAL CLASS

Working Pressures by Classes, psig								
Temperature, °F	150	300	400	600	900	1500	2500	4500
-20 to 100	290	750	1,000	1,500	2,250	3,750	6,250	11,250
200	255	670	890	1,335	2,005	3,345	5,570	10,030
300	230	600	800	1,200	1,800	3,000	5,000	9,000
400	210	555	735	1,105	1,660	2,765	4,605	8,295
500	200	520	690	1,035	1,555	2,595	4,320	7,780
600	185	490	650	975	1,465	2,440	4,065	7,315
650	185	480	640	960	1,440	2,395	3,995	7,190
700	180	470	630	945	1,415	2,355	3,930	7,070
750	175	465	615	925	1,390	2,315	3,855	6,945
800	175	450	600	900	1,350	2,250	3,750	6,750
850	170	440	590	885	1,325	2,205	3,680	6,620
900	165	435	575	865	1,300	2,165	3,605	6,495
950	165	425	565	850	1,275	2,120	3,535	6,365
1000	155	405	545	815	1,220	2,035	3,395	6,105
1050	150	385	515	770	1,155	1,930	3,215	5,785
1100	125	320	430	645	965	1,605	2,680	4,820
1150	95	250	330	495	745	1,245	2,070	3,730
1200	75	195	255	385	580	965	1,605	2,895
1250	55	140	190	285	425	705	1,180	2,120
1300	40	105	145	215	320	535	895	1,605
1350	30	75	105	155	230	385	645	1,155
1400	25	60	80	120	180	300	500	900
1450	15	45	55	85	130	215	355	645
1500	15	35	45	70	105	170	285	515

NOTE: Special Class Ratings apply to Threaded and Weld End Valves only and require upgrading per paragraph 8 of ASME B16.34

PRESSURE/TEMPERATURE RATINGS

TABLE 8

ASTM A351 Grade CF3M^(a) ASTM A351 Grade CF8M^(b)

(a) Not to be used over 850° F

(b) At temperatures over 1000° F, use only when the carbon content is 0.04% or higher. This requirement must be specified by customer when applicable.

STANDARD CLASS

Working Pressures by Classes, psig									
Temperature, °F(2)	150	200	300	400	600	900	1500	2500	4500
-20 to 100	275	400	720	960	1,440	2,160	3,600	6,000	10,800
200	235	360	620	825	1,240	1,860	3,095	5,160	9,290
300	215	330	560	745	1,120	1,680	2,795	4,660	8,390
400	195	300	515	685	1,025	1,540	2,570	4,280	7,705
500	170	270	480	635	955	1,435	2,390	3,980	7,165
600	140	240	450	600	900	1,355	2,255	3,760	6,770
650	125	230	445	590	890	1,305	2,170	3,700	6,660
700	110	215	430	580	870	1,305	2,170	3,620	6,515
750	95	205	425	570	855	1,280	2,135	3,560	6,410
800	80	190	420	565	845	1,265	2,110	3,520	6,335
850	65	180	420	555	835	1,255	2,090	3,480	6,265
900	50	170	415	555	830	1,245	2,075	3,460	6,230
950	35	150	385	515	775	1,160	1,930	3,220	5,795
1000	20	130	350	465	700	1,050	1,750	2,915	5,245
1050	20(1)	125	345	460	685	1,030	1,720	2,865	5,155
1100	20(1)	115	305	405	610	915	1,525	2,545	4,575
1150	20(1)	90	235	315	475	710	1,185	1,970	3,550
1200	20(1)	75	185	245	370	555	925	1,545	2,775
1250	20(1)	60	145	195	295	440	735	1,230	2,210
1300	20(1)	50	115	155	235	350	585	970	1,750
1350	20(1)	45	95	130	190	290	480	800	1,440
1400	20(1)	35	75	100	150	225	380	630	1,130
1450	20(1)	30	60	80	115	175	290	485	875
1500	20(1)	25	40	55	85	125	205	345	620

NOTE:

(1) For welding end valves only. Flanged end ratings terminate at 1000° F.

(2) For Cryogenic Valves, - 20° F Rating Extends to -423° F.

SPECIAL CLASS

Working Pressures by Classes, psig									
Temperature, °F(2)	150	300	400	600	900	1500	2500	4500	
-20 to 100	290	750	1,000	1,500	2,250	3,750	6,250	11,250	
200	265	690	920	1,380	2,070	3,450	5,750	10,350	
300	240	625	830	1,250	1,870	3,120	5,200	9,360	
400	220	570	760	1,140	1,710	2,850	4,750	8,550	
500	205	530	710	1,065	1,595	2,655	4,430	7,970	
600	195	505	670	1,005	1,510	2,520	4,195	7,555	
650	190	495	655	985	1,480	2,465	4,105	7,395	
700	185	485	645	970	1,455	2,420	4,035	7,265	
750	180	475	635	950	1,425	2,380	3,965	7,135	
800	180	470	630	945	1,415	2,355	3,930	7,070	
850	180	465	620	930	1,400	2,330	3,885	6,990	
900	175	465	615	925	1,390	2,315	3,855	6,945	
950	175	460	610	915	1,375	2,290	3,815	6,870	
1000	160	420	560	840	1,260	2,105	3,505	6,310	
1050	160	420	560	840	1,260	2,105	3,505	6,310	
1100	145	380	510	765	1,145	1,905	3,180	5,720	
1150	115	295	395	590	885	1,480	2,465	4,435	
1200	90	230	310	465	695	1,155	1,930	3,470	
1250	70	185	245	370	555	920	1,535	2,765	
1300	55	145	195	290	435	730	1,215	2,185	
1350	45	120	160	240	360	600	1,000	1,800	
1400	35	95	125	190	285	470	785	1,415	
1450	30	75	100	145	220	365	610	1,095	
1500	20	50	70	105	155	260	430	770	

NOTE: Special Class Ratings apply to Threaded and Weld End Valves only and require upgrading per paragraph 8 of ASME B16.34

PRESSURE/TEMPERATURE RATINGS

TABLE 9

ASTM A351-Grade CN7M

Use solution annealed material only.

STANDARD CLASS

Working Pressures by Classes, psig								
Temperature, °F	150	300	400	600	900	1500	2500	4500
-20 to 100	230	600	800	1,200	1,800	3,000	5,000	9,000
200	200	520	690	1,035	1,555	2,590	4,320	7,775
300	180	465	620	930	1,395	2,330	3,880	6,985
400	160	420	565	845	1,265	2,110	3,520	6,335
500	150	390	520	780	1,165	1,945	3,240	5,830
600	140	360	480	720	1,080	1,800	3,000	5,400

SPECIAL CLASS

Working Pressure by Classes, psig								
Temperature, °F	150	300	400	600	900	1500	2500	4500
-20 to 100	255	665	885	1,330	1,995	3,320	5,535	9,965
200	215	560	750	1,125	1,685	2,805	4,680	8,420
300	195	510	680	1,020	1,530	2,550	4,250	7,650
400	180	470	630	945	1,415	2,355	3,930	7,070
500	165	435	580	870	1,300	2,170	3,615	7,070
600	155	400	535	805	1,205	2,010	3,350	6,025

NOTE: Special class Ratings apply to Threaded and Weld End Valves only and require upgrading per paragraph 8 of ASME B16.34

PRESSURE/TEMPERATURE RATINGS

TABLE 10

ASTM B61 and B62 BRONZE

PRESS. CLASS	PRESSURE (c) - psig					
	125	150		200	300	
END CONN.	THD	THD	FLG (b)	THD	THD (e)	THD
TEMP (a) deg. F	MATERIAL					
	ASTM B-62			ASTM B-61		
-20 To 150	200	300	225	400	1000	600
200	185	270	210	375	920	560
250	170	240	195	350	830	525
300	155	210	180	325	740	490
350	140	180	165	300	650	450
400	--	--	--	275	560	410
406	125	150	150	--	--	--
450	120 (d)	145(d)	--	250	480	375
500	--	--	--	225	390	340
550	--	--	--	200	300	300

NOTES:

- (a) For Cryogenic Valves, -20°F ratings extend to -325°F
- (b) P-T Ratings - ASME B16.24
- (c) Solder Joint Valve Ratings may be limited by the solder composition. See MSS SP-80 Paragraph 2.4 and Annex A for more information
- (d) Some codes (i.e.-ASME BPVC, Section 1) limit the rating temperatures of the indicated material to 406°F
- (e) Alternate Ratings for valve sizes 1/8-2 having threaded ends and metal to metal union ring body-bonnet joints.

PRESSURE/TEMPERATURE RATINGS

TABLE 11

ASTM A126-B IRON

Temp. Degrees F.	PRESSURE (psig)				
	CLASS 125			CLASS 250	
	NPS 2-12	NPS 14-24	NPS 30-48	NPS 2-12	NPS 14-24
-20 to 150	200	150	150	500	300
200	190	135	115	460	280
225	180	130	100	440	270
250	175	125	85	415	260
275	170	120	65	395	250
300	165	110	50	375	240
325	155	105		355	230
350	150	100		335	220
375	145			315	210
400	140			290	200
425	130			270	
450	125			250	

CHEMICAL AND PHYSICAL PROPERTIES CAST CARBON AND ALLOY STEELS

TABLE 12

ASTM STANDARD		A216	A217	A217	A217	A217	A217	A352	A352
GRADE		WCB***	WC6	WC9	C5	C12	C12A**	LCB	LC3
CARBON (C)	(Min)	-	0.05	0.05	-	-	-	-	-
	(Max)	0.30	0.20	0.18	0.20	0.20	0.12	0.30	0.15
MANGANESE (Mn)	(Min)	-	0.50	0.40	0.40	0.35	0.30	-	0.50
	(Max)	1.00	0.80	0.70	0.70	0.65	0.60	1.00	0.80
PHOSPHOROUS (P)	(Min)	-	-	-	-	-	-	-	-
	(Max)	0.04	0.04	0.04	0.04	0.04	0.020	0.04	0.04
SULFUR (S)	(Min)	-	-	-	-	-	-	-	-
	(Max)	0.045	0.045	0.045	0.045	0.045	0.018	0.045	0.045
SILICON (Si)	(Min)	-	-	-	-	-	0.20	-	-
	(Max)	0.60	0.60	0.60	0.75	1.00	0.50	0.60	0.60
COPPER (Cu)	(Min)	-	-	-	-	-	-	-	-
	(Max)	0.30*	0.50*	0.50*	0.50*	0.50*	-	0.30*	-
NICKEL (Ni)	(Min)	-	-	-	-	-	-	-	3.00
	(Max)	0.50*	0.50*	0.50*	0.50*	0.50*	0.40	0.50*	4.00
CHROMIUM (Cr)	(Min)	-	-	2.00	4.00	8.00	8.0	-	-
	(Max)	0.50*	-	2.75	6.50	10.00	9.5	0.50*	-
MOLYBDENUM (Mo)	(Min)	-	-	0.90	0.45	0.90	0.85	-	-
	(Max)	0.20*	-	1.20	0.65	1.20	1.05	0.20*	-
VANADIUM (V)	(Min)	-	-	-	-	-	0.18	-	-
	(Max)	0.03*	-	-	-	-	0.25	0.03*	-
TUNGSTEN (W)	(Min)	-	-	-	-	-	-	-	-
	(Max)	-	0.10*	0.10*	0.10*	0.10*	-	-	-
COLUMBIUM (Cb)	(Min)	-	-	-	-	-	0.060	-	-
	(Max)	-	-	-	-	-	0.10	-	-
TENSILE STRENGTH	(Min)	70 Ksi	70 Ksi	70 Ksi	90 Ksi	90 Ksi	85 Ksi	65 Ksi	70 Ksi
	(Max)	90	95	95	115	115	110	90	95
YIELD STRENGTH	(Min)	36 Ksi	40 Ksi	40 Ksi	60 Ksi	60 Ksi	60 Ksi	35 Ksi	40 Ksi
	(Max)	-	-	-	-	-	-	-	-
ELONGATION	(Min)	22%	20%	20%	18%	18%	20%	24%	24%
	(Max)	-20F	-20F	-20F	-20F	-20F	-20F	-50F	-150F
TEMPERATURE	(Min)	-20F	-20F	-20F	-20F	-20F	-20F	-50F	-150F
	(Max)	800F	1100F	1100F	1200F	1200F	1200F	650F	650F

* RESIDUAL ELEMENTS-Maximum total must not exceed 1.00

** NITROGEN RANGE is 0.030 to 0.070 and ALUMINUM is 0.040 Max.

*** For A216WCB, The Maximum Manganese May Increase 0.04%, Up to 1.28% Maximum, For Each Reduction Of 0.01% Below The Specified Maximum Carbon Content.

NOTE: Chemical Compositions Are In Units Of Percent.

CHEMICAL AND PHYSICAL PROPERTIES CAST STAINLESS STEELS AND NICKEL ALLOYS

TABLE 13

ASTM STANDARD	A351	A351	A351	A351	A351	A351	A494	A494	A494	A494	
GRADE	CF3	CF8	CF3M	CF8M	CN7M	CD4MCu	CZ100	M35-1	N12MV	CW12MW	
TYPE	304L	304	316L	316	Alloy20	Duplex	Nickel	Monel	Hast.B	Hast.C	
CARBON (C)	(Min) (Max)	- 0.03	- 0.08	- 0.03	- 0.08	- 0.07	- 0.04	- 1.00	- 0.35	- 0.12	- 0.12
MANGANESE (Mn)	(Min) (Max)	- 1.50	- 1.50	- 1.50	- 1.50	- 1.50	- 1.00	- 1.50	- 1.50	- 1.00	- 1.00
PHOSPHOROUS (P)	(Min) (Max)	- 0.040	- 0.040	- 0.040	- 0.040	- 0.040	- 0.04	- 0.03	- 0.03	- 0.040	- 0.040
SULFUR (S)	(Min) (Max)	- 0.040	- 0.040	- 0.040	- 0.040	- 0.040	- 0.04	- 0.03	- 0.03	- 0.030	- 0.030
SILICON (Si)	(Min) (Max)	- 2.00	- 2.00	- 1.50	- 1.50	- 1.50	- 1.00	- 2.00	- 1.25	- 1.00	- 1.00
COPPER (Cu)	(Min) (Max)	- -	- -	- -	- -	3.0 4.0	2.75 3.25	- 1.25	26.0 33.0	- -	- -
NICKEL (Ni)	(Min) (Max)	8.0 12.0	8.0 11.0	9.0 13.0	9.0 12.0	27.5 30.5	4.75 6.00	95.00 -	- Balance	- Balance	- Balance
CHROMIUM (Cr)	(Min) (Max)	17.0 21.0	18.0 21.0	17.0 21.0	18.0 21.0	19.0 22.0	24.5 26.5	- -	- 1.00	- 1.00	15.5 17.5
MOLYBDENUM (Mo)	(Min) (Max)	- 0.50	- 0.50	2.0 3.0	2.0 3.0	2.0 3.0	1.75 2.25	- -	- -	26.0 30.0	16.0 18.0
VANADIUM (V)	(Min) (Max)	- -	- -	- -	- -	- -	- -	- -	- 0.20	0.20 0.60	0.20 0.40
TUNGSTEN (W)	(Min) (Max)	- -	- -	- -	- -	- -	- -	- -	- -	- -	3.75 5.25
COLUMBIUM (Cb)	(Min) (Max)	- -	- -	- -	- -	- -	- -	- 0.5	- -	- -	- -
IRON (Fe)	(Min) (Max)	- -	- -	- -	- -	- -	- 3.00	- -	- 4.0	4.0 6.0	4.5 7.5
TENSILE STRENGTH	(Min)	70 Ksi	70 Ksi	70 Ksi	70 Ksi	62 Ksi	100 Ksi	50 Ksi	65 Ksi	76 Ksi	72 Ksi
YIELD STRENGTH	(Min)	30 Ksi	30 Ksi	30 Ksi	30 Ksi	25 Ksi	70 Ksi	18 Ksi	25 Ksi	40 Ksi	40 Ksi
ELONGATION	(Min)	35.0%	35.0%	30.0%	30.0%	35.0%	16.0%	10.0%	25.0%	6.0%	4.0%
TEMPERATURE	(Min) ** (Max)	-425F 800F	-425F 1500F*	-425F 850F	-425F 1500F*	-325F 600F	-20F 600F	-325F 600F	-325F 900F	-325F 1000F	-325F 1000F

* For temperatures over 1000F, minimum Carbon is 0.04. Customer must specify if temperature is over 1000F and this minimum Carbon is required.

** For temperature below -50F Special cryogenic cleaning and bonnet extensions may be required. See Cryogenic section of catalog for more information.

NOTE: Chemical Compositions Are In Units Of Percent

TRIM DESCRIPTIONS

TABLE 14

Trim No.	Seat Nominal Designation	Seat Nominal Composition	Nominal Hardness (HB)	Typical Stem/Backseat Material	Acceptable Alternate Trim No.
1	F6	13 Cr	250(a)	TYPE 410 or 420 (13Cr)	8 or 8A
2	304	18Cr-8Ni	-	TYPE 304(18Cr-8Ni)	10
3	310	25Cr-20Ni	-	TYPE 310 (25Cr-20Ni)	-
4	HardF6	Hard 13Cr	750	TYPE 410 or 420 (13 Cr)	-
5	Hardfaced	Co-CrA (b)	350	TYPE 410 or 420 (13 Cr)	-
5A	Hardfaced	Ni-Cr	350	TYPE 410 Or 420 (13 Cr)	5
6	F6 and	13 Cr	250	TYPE 410 or 420 (13 Cr)	8
	Cu-Ni	Cu-Ni	175	TYPE 410 or 420 (13 Cr)	-
7	F6 and	13 Cr	250	TYPE 410 or 420 (13 Cr)	-
	Hard F6	Hard 13 Cr	750		
8	F6 and	13 Cr	250	TYPE 410 or 420 (13 Cr)	-
	Hardfaced	Co-CrA (b)	350		
8A	F6 and	13 Cr	250	TYPE 410 or 420 (13 Cr)	8
	Hardfaced	Ni-Cr	350		
9	Monel	Ni-Cu Alloy	-	Monel (Ni-Cu)	-
10	316	18 Cr-8Ni-2Mo	-	TYPE 316 (18Cr-8Ni-2Mo)	-
11	Monel and	Ni-Cu Alloy	-	Monel (Ni-Cu)	-
	Hardfaced	Trim 5 or 5A	350		
12	316 and	18Cr-18Ni-2Mo	-	Type 316 (18Cr-8Ni-2Mo)	-
	Hardfaced	Trim 5 or 5A	350		
13	Alloy 20	19Cr-29Ni	-	Alloy 20 (19Cr-29Ni)	-
14	Alloy 20 and	19Cr-29Ni	-	Alloy 20 (19Cr-29Ni)	-
	Hardfaced	Trim 5 or 5A	350		
15	Hardfaced	Co-Cr-A(b)	350	TYPE 304 (18Cr-8Ni)	-
16	Hardfaced	Co-Cr-A(b)	350	TYPE 316 (18Cr-8Ni-2Mo)	-
17	Hardfaced	Co-Cr-A(b)	350	TYPE 347 (18Cr-10Ni)	-
18	Hardfaced	Co-Cr-A(b)	350	Alloy 20 (19Cr-29Ni)	-

- (a) Minimum 50HB Differential Hardness Between Mating Seating Surfaces
- (b) Stellite 6™ or Equal.

DIMENSIONS OF WROUGHT STEEL PIPE AND WELD END CONFIGURATIONS

TABLE 15

INCH NOMINAL SIZE	PIPE DIMENSIONS		IDENTIFICATION		WELD END DIMENSIONS*		
	OUTSIDE DIAMETER IN.	WALL THICKNESS IN.	SCHEDULE		VALVE OD A IN.	PIPE ID** B IN.	C IN.
1/4	0.540	0.065	10/10S		0.410	
	0.540	0.088	STD	40/40S		0.364	
	0.540	0.119	XS	80/80S		0.302	
3/8	0.675	0.065	10/10S		0.545	
	0.675	0.091	STD	40/40S		0.493	
	0.675	0.126	XS	80/80S		0.423	
1/2	0.840	0.083	10/10S		0.674	
	0.840	0.109	STD	40/40S		0.622	
	0.840	0.147	XS	80/80S		0.546	
3/4	1.050	0.083	10/10S		0.884	
	1.050	0.113	STD	40/40S		0.824	
	1.050	0.154	XS	80/80S		0.742	
1	1.315	0.109	10/10S		1.097	
	1.315	0.133	STD	40/40S		1.049	
	1.315	0.179	XS	80/80S		0.957	
1-1/4	1.660	0.109	10/10S		1.442	
	1.660	0.140	STD	40/40S		1.380	
	1.660	0.191	XS	80/80S		1.278	
1-1/2	1.900	0.109	10/10S		1.682	
	1.900	0.145	STD	40/40S		1.610	
	1.900	0.200	XS	80/80S		1.500	
2	2.375	0.109	10/10S		2.157	
	2.375	0.154	STD	40/40S		2.067	
	2.375	0.218	XS	80/80S		1.939	
2-1/2	2.875	0.120	10/10S	2.96	2.635	
	2.875	0.203	STD	40/40S	2.96	2.469	2.479
	2.875	0.276	XS	80/80S	2.96	2.323	2.351
	2.875	0.375	160	2.96	2.125	2.178
	2.875	0.552	XXS	2.96	1.771	1.868
3	3.500	0.120	10/10S	3.59	3.260	
	3.500	0.216	STD	40/40S	3.59	3.068	3.081
	3.500	0.300	XS	80/80S	3.59	2.900	2.934
	3.500	0.438	160	3.59	2.624	2.692
	3.500	0.600	XXS	3.59	2.300	2.409

* SEE FIGURES 1 AND 2

** "B" DIMENSION OF WELD END CORRESPONDS TO PIPE ID DIMENSION

DIMENSIONS OF WROUGHT STEEL PIPE AND WELD END CONFIGURATIONS

TABLE 15 (cont.)

PIPE DIMENSIONS			IDENTIFICATION		WELD END DIMENSIONS*		
INCH NOMINAL SIZE	OUTSIDE DIAMETER IN.	WALL THICKNESS IN.	SCHEDULE		VALVE OD A IN.	PIPE ID**	
						B IN.	C IN.
4	4.500	0.120	10/10S	4.62	4.260	
	4.500	0.237	STD	40/40S	4.62	4.026	4.044
	4.500	0.337	XS	80/80S	4.62	3.826	3.869
	4.500	0.438	120	4.62	3.624	3.692
	4.500	0.531	160	4.62	3.428	3.530
	4.500	0.674	XXS	4.62	3.152	3.279
6	6.625	0.134	10/10S	6.78	6.357	
	6.625	0.280	STD	40/40S	6.78	6.065	6.094
	6.625	0.432	XS	80/80S	6.78	5.761	5.828
	6.625	0.562	120	6.78	5.501	5.600
	6.625	0.719	160	6.78	5.187	5.326
	6.625	0.864	XXS	6.78	4.897	5.072
8	8.625	0.148	10/10S	8.78	8.329	
	8.625	0.250	20	8.78	8.125	
	8.625	0.322	STD	40/40S	8.78	7.981	8.020
	8.625	0.406	60	8.78	7.813	7.873
	8.625	0.500	XS	80/80S	8.78	7.625	7.709
	8.625	0.594	100	8.78	7.437	7.544
	8.625	0.719	120	8.78	7.187	7.326
	8.625	0.812	140	8.78	7.001	7.163
	8.625	0.875	XXS	8.78	6.875	7.053
	8.625	0.906	160	8.78	6.813	6.998
10	10.750	0.165	10/10S	10.94	10.420	
	10.750	0.250	20/20S	10.94	10.250	
	10.750	0.365	STD	40/40S	10.94	10.020	10.070
	10.750	0.500	XS	60/80S	10.94	9.750	9.834
	10.750	0.594	80	10.94	9.562	9.670
	10.750	0.719	100	10.94	9.312	9.451
	10.750	0.844	120	10.94	9.062	9.232
	10.750	1.000	XXS	140	10.94	8.750	8.959
	10.750	1.125	160	10.94	8.500	8.740
	12	12.750	0.180	10/10S	12.97	12.390
12.750		0.250	20	12.97	12.250	
12.750		0.375	STD	40S	12.97	12.000	12.053
12.750		0.406	40	12.97	11.938	11.999
12.750		0.500	XS	80S	12.97	11.750	11.834
12.750		0.562	60	12.97	11.626	11.725
12.750		0.688	80	12.97	11.374	11.505
12.750		0.844	100	12.97	11.062	11.232
12.750		1.000	XXS	120	12.97	10.750	10.959
12.750		1.125	140	12.97	10.500	10.740
12.750		1.312	160	12.97	10.126	10.413

* SEE FIGURES 1 AND 2

** "B" DIMENSION OF WELD END CORRESPONDS TO PIPE ID DIMENSION

DIMENSIONS OF WROUGHT STEEL PIPE AND WELD END CONFIGURATIONS

TABLE 15 (cont.)

PIPE DIMENSIONS			IDENTIFICATION		WELD END DIMENSIONS*			
INCH NOMINAL SIZE	OUTSIDE DIAMETER IN.	WALL THICKNESS IN.	SCHEDULE		VALVE OD A IN.	PIPE ID** B IN.	C IN.	
14	14.000	0.188	10S	14.25	13.624		
	14.000	0.250	10	14.25	13.500		
	14.000	0.312	20	14.25	13.376		
	14.000	0.375	STD	30	14.25	13.250	13.303	
	14.000	0.438	40	14.25	13.124	13.192	
	14.000	0.500	XS	14.25	13.000	13.084	
	14.000	0.594	60	14.25	12.812	12.920	
	14.000	0.750	80	14.25	12.500	12.646	
	14.000	0.938	100	14.25	12.124	12.318	
	14.000	1.094	120	14.25	11.812	12.044	
	14.000	1.250	140	14.25	11.500	11.771	
	14.000	1.406	160	14.25	11.188	11.498	
	16	16.000	0.188	10s	16.25	15.624	
16.000		0.250	10	16.25	15.500		
16.000		0.312	20	16.25	15.376		
16.000		0.375	STD	30	16.25	15.250	15.303	
16.000		0.500	XS	40	16.25	15.000	15.084	
16.000		0.656	60	16.25	14.688	14.811	
16.000		0.844	80	16.25	14.312	14.482	
16.000		1.031	100	16.25	13.938	14.155	
16.000		1.219	120	16.25	13.562	13.826	
16.000		1.438	140	16.25	13.124	13.442	
16.000		1.594	160	16.25	12.812	13.170	
18		18.000	0.188	10S	18.28	17.624	
		18.000	0.250	10	18.28	17.500	
	18.000	0.312	20	18.28	17.376		
	18.000	0.375	STD	18.28	17.250	17.303	
	18.000	0.500	XS	18.28	17.000	17.084	
	18.000	0.562	40	18.28	16.876	16.975	
	18.000	0.750	60	18.28	16.500	16.646	
	18.000	0.938	80	18.28	16.124	16.318	
	18.000	1.156	100	18.28	15.688	15.936	
	18.000	1.375	120	18.28	15.250	15.553	
	18.000	1.562	140	18.28	14.876	15.225	
	18.000	1.781	160	18.28	14.438	14.842	
	20	20.000	0.218	10S	20.31	19.564	
20.000		0.250	10	20.31	19.500		
20.000		0.375	STD	20	20.31	19.250	19.303	
20.000		0.500	XS	30	20.31	19.000	19.084	
20.000		0.594	40	20.31	18.812	18.920	

* SEE FIGURES 1 AND 2

** "B" DIMENSION OF WELD END CORRESPONDS TO PIPE ID DIMENSION

DIMENSIONS OF WROUGHT STEEL PIPE AND WELD END CONFIGURATIONS

TABLE 15 (cont.)

INCH NOMINAL SIZE	PIPE DIMENSIONS		IDENTIFICATION		WELD END DIMENSIONS*		
	OUTSIDE DIAMETER IN.	WALL THICKNESS IN.	SCHEDULE		VALVE OD A IN.	PIPE ID** B IN.	C IN.
24	20.000	0.812	60	20.31	18.376	18.538
	20.000	1.031	80	20.31	17.938	18.155
	20.000	1.281	100	20.31	17.438	17.717
	20.000	1.500	120	20.31	17.000	17.334
	20.000	1.750	140	20.31	16.500	16.896
	20.000	1.969	160	20.31	16.062	16.513
	24.000	0.250	10/10S	24.38	23.500	
	24.000	0.375	STD	20	24.38	23.250	23.303
	24.000	0.500	XS	24.38	23.000	23.084
	24.000	0.562	30	24.38	22.876	22.975
	24.000	0.688	40	24.38	22.624	22.755
	24.000	0.969	60	24.38	22.062	22.263
	24.000	1.219	80	24.38	21.562	21.826
	24.000	1.531	100	24.38	20.938	21.280
24.000	1.812	120	24.38	20.376	20.788	
24.000	2.062	140	24.38	19.876	20.350	
24.000	2.344	160	24.38	19.312	19.857	
30	30.000	0.312	10/10S	30.38	29.376	29.413
	30.000	0.375	STD	30.38	29.250	
	30.000	0.500	XS	20	30.38	29.000	29.084
	30.000	0.625	30	30.38	28.750	28.865
36	36.000	0.312	10	36.50	35.376	35.413
	36.000	0.375	STD	36.50	35.250	
	36.000	0.500	XS	20	36.50	35.000	35.084
	36.000	0.625	30	36.50	34.750	34.865
	36.000	0.750	40	36.50	34.500	34.646
42	42.000	0.375	STD		41.250	
	42.000	0.500	XS		41.000	

* SEE FIGURES 1 AND 2

** "B" DIMENSION OF WELD END CORRESPONDS TO PIPE ID DIMENSION

FIG. 1 TYPICAL WELD BEVEL DETAILS FOR WALL THICKNESS NOT OVER 22 mm (0.88 in.)

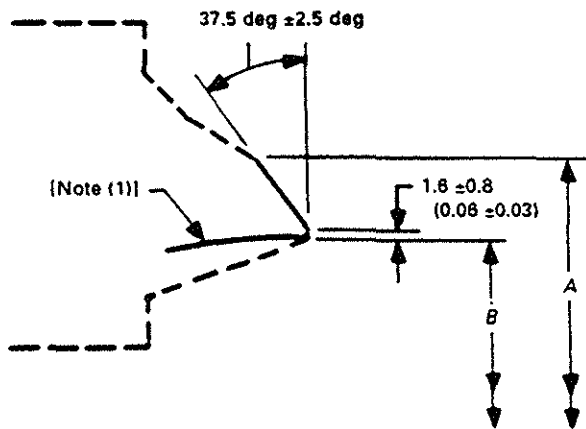

(a) Welding End Detail for Joint without Backing Ring

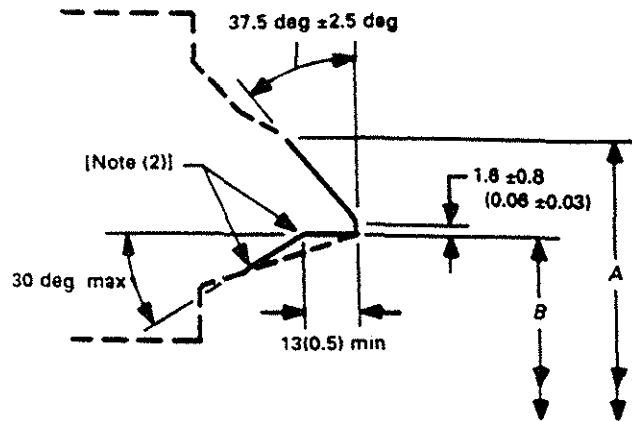

(b) Welding End Detail for Joint Using Split Rectangular Backing Ring

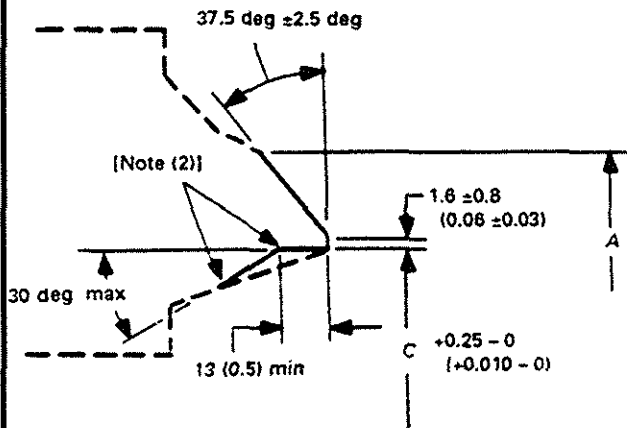

(c) Welding End Detail for Joint Using Continuous Rectangular Backing Ring

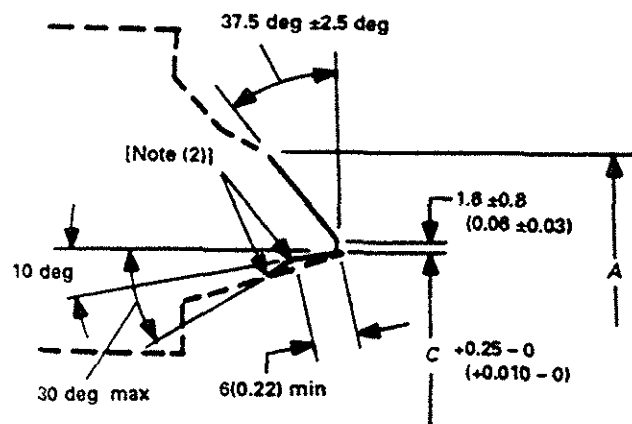

(d) Welding End Detail for Joint Using Continuous Tapered Backing Ring

GENERAL NOTES:

- (a) Broken lines denote maximum envelope for transitions from welding bevel and root face into body of component. See Fig. 1 of ASME B16.25 for details
- (b) Purchase order must specify contour of any backing ring to be used.
- (c) Linear dimensions are in millimeters with inch values in parentheses.

NOTES:

- (1) Internal surface may be as-formed or machined for dimension B at root face.
- (2) Intersections should be slightly rounded.

FIG.2 TYPICAL WELD BEVEL DETAILS FOR WALL THICKNESS OVER 22 mm (0.88 in.)

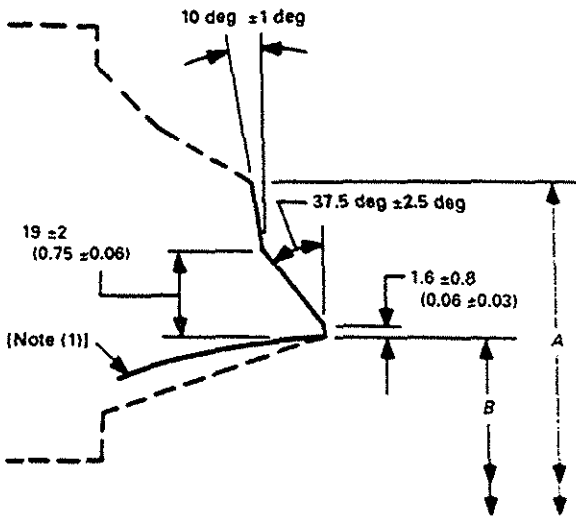

(a) Welding End Detail for Joint without Backing Ring

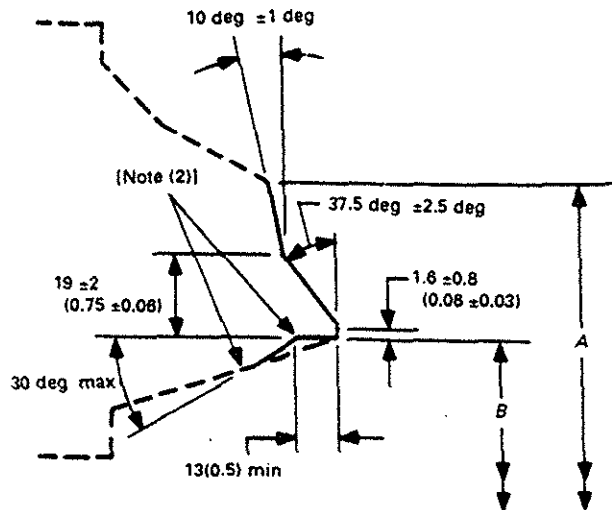

(b) Welding End Detail for Joint Using Split Rectangular Backing Ring

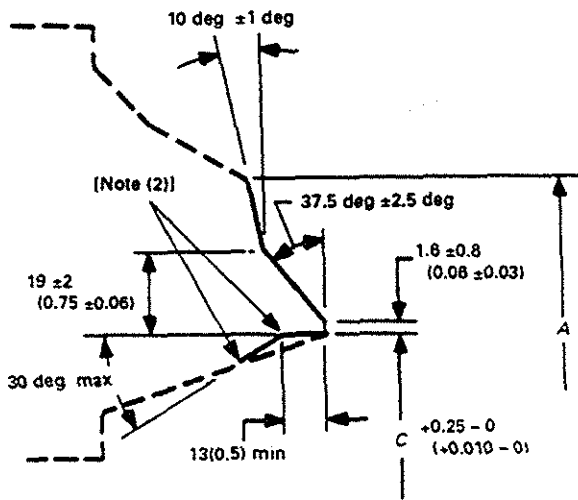

(c) Welding End Detail for Joint Using Continuous Rectangular Backing Ring

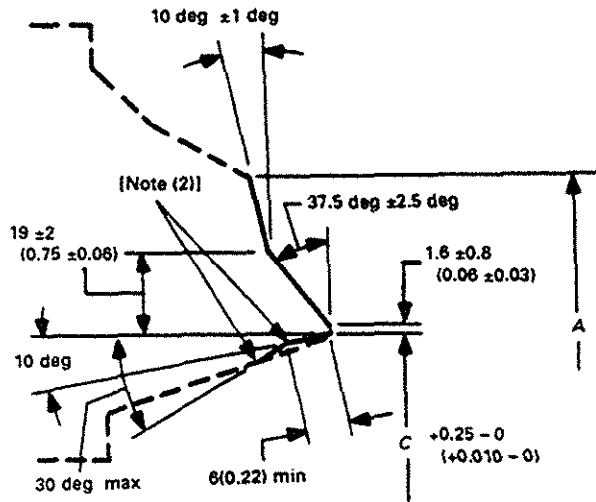

(d) Welding End Detail for Joint Using Continuous Tapered Backing Ring

GENERAL NOTES:

- (a) Broken lines denote maximum envelope for transitions from welding groove and root face into body of component. See Fig. 1 of ASME B16.25 for details
- (b) Purchase order must specify contour of any backing ring to be used.
- (c) Linear dimensions are in millimeters with inch values in parentheses.

NOTES:

- (1) Internal surface may be as-formed or machined for dimension B at root face.
- (2) Intersections should be slightly rounded.

FLANGE DIMENSIONS

For valve sizes through 24", Powell's standard for flange dimensions is ASME B16.5.
For valve sizes larger than 24", there are two standards that are available as follows:

- (1) ASME B16.47 Series A (equivalent to MSS SP-44)
- or (2) ASME B16.47 Series B (equivalent to API 605)

For valve sizes over 24", the flange type required (Series A or Series B) must be clearly specified.
For Reference Purposes the following Tables contain Flange Dimensions as described below:

TABLE 16: ASME B16.5 CLASSES 150 and 300, Sizes ½" through 24"

TABLE 17: ASME B16.5 CLASSES 600 and 900, Sizes ½" through 24"

TABLE 18: ASME B16.47 SERIES A, CLASS 150, Sizes 26" through 60"

TABLE 19: ASME B16.47 SERIES A, CLASS 300, Sizes 26" through 60"

TABLE 20: ASME B16.47 SERIES B, CLASS 150, Sizes 26" through 60"

TABLE 21: ASME B16.47 SERIES B, CLASS 300, Sizes 26" through 60"

STEEL VALVE FLANGE DIMENSIONS

TABLE 16

All Dimensions in Units of Inches

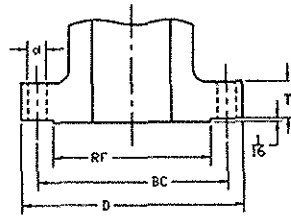

CLASS 150

Nominal Pipe Size	Outside Diameter of Flange	Diameter of Bolt Circle	Diameter of Bolt Holes	Number of Bolts	Thickness	Raised Face Diameter
	(D)	(BC)	(d)		(T)	(RF)
1/2	3.50	2.38	0.62	4	0.38	1.38
3/4	3.88	2.75	0.62	4	0.41	1.69
1	4.25	3.12	0.62	4	0.44	2.00
1 1/4	4.62	3.50	0.62	4	0.50	2.50
1 1/2	5.00	3.88	0.62	4	0.56	2.88
2	6.00	4.75	0.75	4	0.62	3.62
2 1/2	7.00	5.50	0.75	4	0.69	4.12
3	7.50	6.00	0.75	4	0.75	5.00
3 1/2	8.50	7.00	0.75	8	0.81	5.50
4	9.00	7.50	0.75	8	0.94	6.19
5	10.00	8.50	0.88	8	0.94	7.31
6	11.00	9.50	0.88	8	1.00	8.50
8	13.50	11.75	0.88	8	1.12	10.62
10	16.00	14.25	1.00	12	1.19	12.75
12	19.00	17.00	1.00	12	1.25	15.00
14	21.00	18.75	1.12	12	1.38	16.25
16	23.50	21.25	1.12	16	1.44	18.50
18	25.00	22.75	1.25	16	1.56	21.00
20	27.50	25.00	1.25	20	1.69	23.00
24	32.00	29.50	1.38	20	1.88	27.25

CLASS 300

Nominal Pipe Size	Outside Diameter of Flange	Diameter of Bolt Circle	Diameter of Bolt Holes	Number of Bolts	Thickness	Raised Face Diameter
	(D)	(BC)	(d)		(T)	(RF)
1/2	3.75	2.62	0.62	4	0.56	1.38
3/4	4.62	3.25	0.75	4	0.62	1.69
1	4.88	3.50	0.75	4	0.69	2.00
1 1/4	5.25	3.88	0.75	4	0.75	2.50
1 1/2	6.12	4.50	0.88	4	0.81	2.88
2	6.50	5.00	0.75	8	0.88	3.62
2 1/2	7.50	5.88	0.88	8	1.00	4.12
3	8.25	6.62	0.88	8	1.12	5.00
3 1/2	9.00	7.25	0.88	8	1.19	5.50
4	10.00	7.88	0.88	8	1.25	6.19
5	11.00	9.25	0.88	8	1.38	7.13
6	12.50	10.62	0.88	12	1.44	8.50
8	15.00	13.00	1.00	12	1.62	10.62
10	17.50	15.25	1.12	16	1.88	12.75
12	20.50	17.75	1.25	16	2.00	15.00
14	23.00	20.25	1.25	20	2.12	16.25
16	25.50	22.50	1.38	20	2.25	18.50
18	28.00	24.75	1.38	24	2.38	21.00
20	30.50	27.00	1.38	24	2.50	23.00
24	36.00	32.00	1.62	24	2.75	27.25

All Dimensions In Units of Inches

STEEL VALVE FLANGE DIMENSIONS

TABLE 17

All Dimensions in Units of Inches

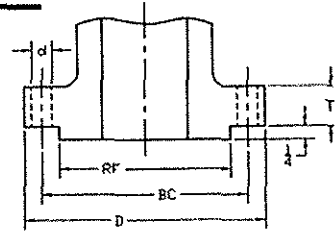

CLASS 600

Nominal Pipe Size	Outside Diameter of Flange (D)	Diameter of Bolt Circle (BC)	Diameter of Bolt Holes (d)	Number of Bolts	Thickness (T)	Raised Face Diameter (RF)
1/2	3.75	2.62	0.62	4	0.56	1.38
3/4	4.62	3.25	0.75	4	0.62	1.69
1	4.88	3.50	0.75	4	0.69	2.00
1 1/4	5.25	3.88	0.75	4	0.81	2.50
1 1/2	6.12	4.50	0.88	4	0.88	2.88
2	6.50	5.00	0.75	8	1.00	3.62
2 1/2	7.50	5.88	0.88	8	1.12	4.12
3	8.25	6.62	0.88	8	1.25	5.00
3 1/2	9.00	7.25	1.00	8	1.38	5.50
4	10.75	8.50	1.00	8	1.50	6.19
5	13.00	10.50	1.12	8	1.75	7.13
6	14.00	11.50	1.12	12	1.88	8.50
8	16.50	13.75	1.25	12	2.19	10.62
10	20.00	17.00	1.38	16	2.50	12.75
12	22.00	19.25	1.38	20	2.62	15.00
14	23.75	20.75	1.50	20	2.75	16.25
16	27.00	23.75	1.62	20	3.00	18.50
18	29.25	25.75	1.75	20	3.25	21.00
20	32.00	28.50	1.75	24	3.50	23.00
24	37.00	33.00	2.00	24	4.00	27.25

CLASS 900

Nominal Pipe Size	Outside Diameter of Flange (D)	Diameter of Bolt Circle (BC)	Diameter of Bolt Holes (d)	Number of Bolts	Thickness (T)	Raised Face Diameter (RF)
1/2	4.75	3.25	0.88	4	0.88	1.38
3/4	5.12	3.50	0.88	4	1.00	1.69
1	5.88	4.00	1.00	4	1.12	2.00
1 1/4	6.25	4.38	1.00	4	1.12	2.50
1 1/2	7.00	4.88	1.12	4	1.25	2.88
2	8.50	6.50	1.00	8	1.50	3.62
2 1/2	9.62	7.50	1.12	8	1.62	4.12
3	9.50	7.50	1.00	8	1.50	5.00
4	11.50	9.25	1.25	8	1.75	6.19
5	13.75	11.00	1.38	8	2.00	7.13
6	15.00	12.50	1.25	12	2.19	8.50
8	18.50	15.50	1.50	12	2.50	10.62
10	21.50	18.50	1.50	16	2.75	12.75
12	24.00	21.00	1.50	20	3.12	15.00
14	25.25	22.00	1.62	20	3.38	16.25
16	27.75	24.25	1.75	20	3.50	18.50
18	31.00	27.00	2.00	20	4.00	21.00
20	33.75	29.50	2.12	20	4.25	23.00
24	41.00	35.50	2.62	20	5.50	27.25

All Dimensions In Units of Inches

DIMENSIONS OF CLASS 150 SERIES A FLANGES

TABLE 18

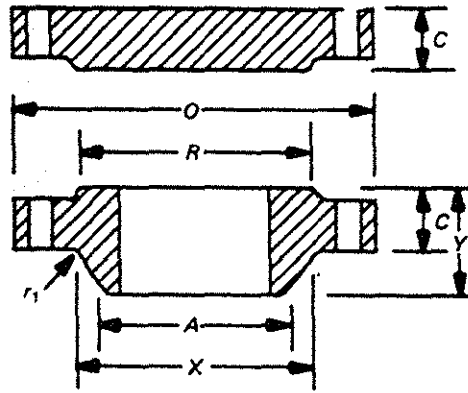

Nominal Pipe Size	2 O.D. of Flange O	3 Thickness of Flange, Min.		5 Length Through Hub Y	6 Diam. Of Hub X	7 Hub Diam. Top A	8 Raised Face Diam. R	9 Drilling				13 Fillet Radius Min. r 1
		4 WNF C	4 Blind C					9 Diam. Of Bolt Circle	10 No. of Bolt Holes	11 Diam. Of Bolt Hole	12 Diam. Of Bolt	
26	34.25	2.69	2.69	4.75	26.62	26.00	29.50	31.75	24	1.38	1 1/4	0.38
28	36.50	2.81	2.81	4.94	28.62	28.00	31.50	34.00	28	1.38	1 1/4	0.44
30	38.75	2.94	2.94	5.38	30.75	30.00	33.75	36.00	28	1.38	1 1/4	0.44
32	41.75	3.19	3.19	5.69	32.75	32.00	36.00	38.50	28	1.62	1 1/2	0.44
34	43.75	3.25	3.25	5.88	34.75	34.00	38.00	40.50	32	1.62	1 1/2	0.50
36	46.00	3.56	3.56	6.19	36.75	36.00	40.25	42.75	32	1.62	1 1/2	0.50
38	48.75	3.44	3.44	6.19	39.00	38.00	42.25	45.25	32	1.62	1 1/2	0.50
40	50.75	3.56	3.56	6.44	41.00	40.00	44.25	47.25	36	1.62	1 1/2	0.50
42	53.00	3.81	3.81	6.75	43.00	42.00	47.00	49.50	36	1.62	1 1/2	0.50
44	55.25	4.00	4.00	7.00	45.00	44.00	49.00	51.75	40	1.62	1 1/2	0.50
46	57.25	4.06	4.06	7.31	47.12	46.00	51.00	53.75	40	1.62	1 1/2	0.50
48	59.50	4.25	4.25	7.56	49.12	48.00	53.50	56.00	44	1.62	1 1/2	0.50
50	61.75	4.38	4.38	8.00	51.25	50.00	55.50	58.25	44	1.88	1 3/4	0.50
52	64.00	4.56	4.56	8.25	53.25	52.00	57.50	60.50	44	1.88	1 3/4	0.50
54	66.25	4.75	4.75	8.50	55.25	54.00	59.50	62.75	44	1.88	1 3/4	0.50
56	68.75	4.88	4.88	9.00	57.38	56.00	62.00	65.00	48	1.88	1 3/4	0.50
58	71.00	5.06	5.06	9.25	59.38	58.00	64.00	67.25	48	1.88	1 3/4	0.50
60	73.00	5.19	5.19	9.44	61.38	60.00	66.00	69.25	52	1.88	1 3/4	0.50

DIMENSIONS OF CLASS 300 SERIES A FLANGES

TABLE 19

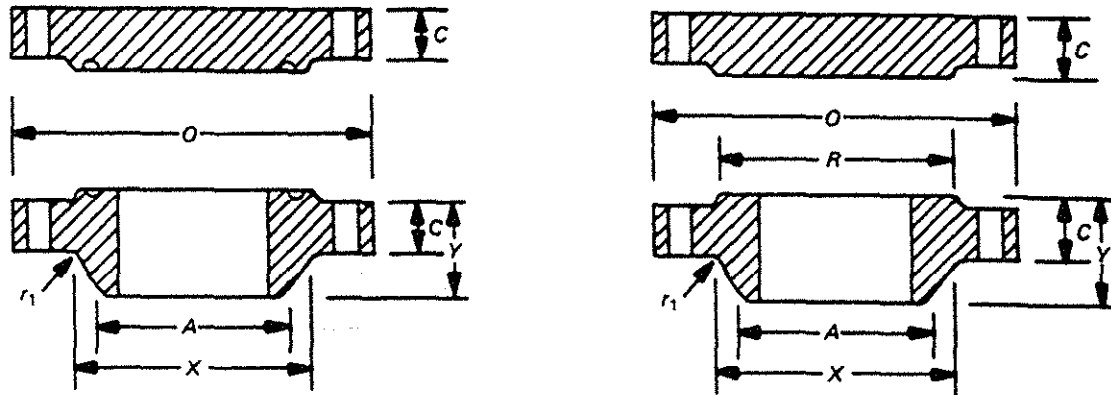

1 Nominal Pipe Size	2 O.D. of Flange O	3 Thickness of Flange, Min.		5 Length Through Hub Y	6 Diam. Of Hub X	7 Hub Diam. Top A	8 Raised Face Diam. R	9 Drilling			12 Diam. Of Bolt	13 Fillet Radius Min. r1
		3 WNF C	4 Blind C					9 Diam. Of Bolt Circle	10 No. of Bolt Holes	11 Diam. Of Bolt Hole		
26	38.25	3.12	3.31	7.25	28.38	26.00	29.50	34.50	28	1.75	1 5/8	0.38
28	40.75	3.38	3.56	7.75	30.50	28.00	31.50	37.00	28	1.75	1 5/8	0.44
30	43.00	3.62	3.75	8.25	32.56	30.00	33.75	39.25	28	1.88	1 3/4	0.44
32	45.25	3.88	3.94	8.75	34.69	32.00	36.00	41.50	28	2.00	1 7/8	0.44
34	47.50	4.00	4.12	9.12	36.88	34.00	38.00	43.50	28	2.00	1 7/8	0.50
36	50.00	4.12	4.38	9.50	39.00	36.00	40.25	46.00	32	2.12	2	0.50
38	46.00	4.25	4.25	7.12	39.12	38.00	40.50	43.00	32	1.62	1 1/2	0.50
40	48.75	4.50	4.50	7.62	41.25	40.00	42.75	45.50	32	1.75	1 5/8	0.50
42	50.75	4.69	4.69	7.88	43.25	42.00	44.75	47.50	32	1.75	1 5/8	0.50
44	53.25	4.88	4.88	8.12	45.25	44.00	47.00	49.75	32	1.88	1 3/4	0.50
46	55.75	5.06	5.06	8.50	47.38	46.00	49.00	52.00	28	2.00	1 7/8	0.50
48	57.75	5.25	5.25	8.81	49.38	48.00	51.25	54.00	32	2.00	1 7/8	0.50
50	60.25	5.50	5.50	9.12	51.38	50.00	53.50	56.25	32	2.12	2	0.50
52	62.25	5.69	5.69	9.38	53.38	52.00	55.50	58.25	32	2.12	2	0.50
54	65.25	6.00	6.00	9.94	55.50	54.00	57.75	61.00	28	2.38	2 1/4	0.50
56	67.25	6.06	6.06	10.25	57.62	56.00	59.75	63.00	28	2.38	2 1/4	0.50
58	69.25	6.25	6.25	10.50	59.62	58.00	62.00	65.00	32	2.38	2 1/4	0.50
60	71.25	6.44	6.44	10.75	61.62	60.00	64.00	67.00	32	2.38	2 1/4	0.50

DIMENSIONS OF CLASS 150 SERIES B FLANGES

TABLE 20

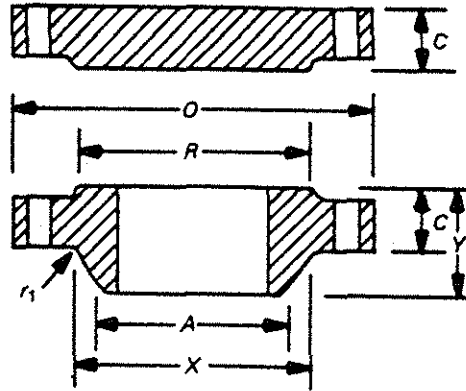

1 Nominal Pipe Size	2 O.D. of Flange O	3 Thickness of Flange, Min.		5 Length Through Hub Y	6 Diam. Of Hub X	7 Hub Diam. Top A	8 Raised Face Diam. R	9 Drilling			12 Diam. Of Bolt	13 Fillet Radius Min. r 1
		4 WNF C	Blind C					9 Diam. Of Bolt Circle	10 No. of Bolt Holes	11 Diam. Of Bolt Hole		
26	30.94	1.62	1.75	3.50	26.94	26.06	28.00	29.31	36	0.88	3/4	0.38
28	32.94	1.75	1.88	3.75	28.94	28.06	30.00	31.31	40	0.88	3/4	0.38
30	34.94	1.75	2.00	3.94	31.00	30.06	32.00	33.31	44	0.88	3/4	0.38
32	37.06	1.81	2.12	4.25	33.06	32.06	34.00	35.44	48	0.88	3/4	0.38
34	39.56	1.94	2.25	4.34	35.12	34.06	36.25	37.69	40	1.00	7/8	0.38
36	41.62	2.06	2.31	4.62	37.19	36.06	38.25	39.75	44	1.00	7/8	0.38
38	44.25	2.12	2.50	4.88	39.25	38.12	40.25	42.12	40	1.12	1	0.38
40	46.25	2.19	2.62	5.06	41.31	40.12	42.50	44.12	44	1.12	1	0.38
42	48.25	2.31	2.69	5.25	43.38	42.12	44.50	46.12	48	1.12	1	0.44
44	50.25	2.38	2.81	5.38	45.38	44.12	46.50	48.12	52	1.12	1	0.44
46	52.81	2.44	2.94	5.69	47.44	46.12	48.62	50.56	40	1.25	1 1/8	0.44
48	54.81	2.56	3.06	5.88	49.50	48.12	50.75	52.56	44	1.25	1 1/8	0.44
50	56.81	2.69	3.18	6.06	51.50	50.12	52.75	54.56	48	1.25	1 1/8	0.44
52	58.81	2.75	3.31	6.19	53.56	52.12	54.75	56.56	52	1.25	1 1/8	0.44
54	61.00	2.81	3.44	6.38	55.62	54.12	56.75	58.75	56	1.25	1 1/8	0.44
56	63.00	2.88	3.56	6.56	57.69	56.12	58.75	60.75	60	1.25	1 1/8	0.56
58	65.94	2.94	3.68	6.88	59.69	58.12	60.75	63.44	48	1.38	1 1/4	0.56
60	67.94	3.00	3.81	7.06	61.81	60.12	63.00	65.44	52	1.38	1 1/4	0.56

DIMENSIONS OF CLASS 300 SERIES B FLANGES

TABLE 21

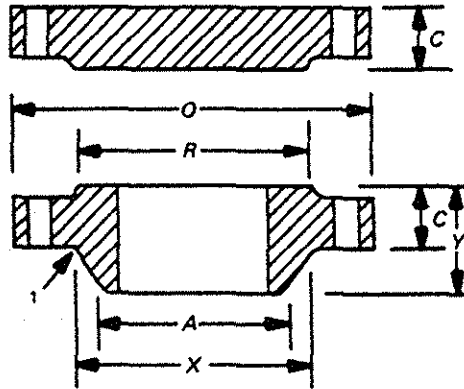

1 Nominal Pipe Size	2 O.D. Of Flange O	3 Thickness of Flange, Min.		5 Length Through Hub Y	6 Diam. Of Hub X	7 Hub Diam. Top A	8 Raised Face Diam. R	9 Drilling				13 Fillet Radius Min. r 1
		3 WNF C	4 Blind C					9 Diam. Of Bolt Circle	10 No. of Bolt Holes	11 Diam. Of Bolt Hole	12 Diam. Of Bolt	
26	34.12	3.50	3.50	5.69	27.62	26.19	29.00	31.62	32	1.38	1 1/4	0.56
28	36.25	3.50	3.50	5.88	29.75	28.19	31.00	33.75	36	1.38	1 1/4	0.56
30	39.00	3.69	3.69	6.22	32.00	30.25	33.25	36.25	36	1.50	1 3/8	0.56
32	41.50	4.06	4.06	6.62	34.00	32.25	35.50	38.50	32	1.62	1 1/2	0.62
34	43.62	4.06	4.06	6.81	36.12	34.25	37.50	40.62	36	1.62	1 1/2	0.62
36	46.12	4.06	4.06	7.12	38.00	36.25	39.75	42.88	32	1.75	1 5/8	0.62
38	48.12	4.38	4.38	7.56	40.00	38.25	41.75	44.88	36	1.75	1 5/8	0.62
40	50.12	4.56	4.56	7.81	42.00	40.25	43.88	46.88	40	1.75	1 5/8	0.62
42	52.50	4.69	4.69	8.06	44.00	42.31	46.00	49.00	36	1.88	1 3/4	0.62
44	54.50	5.00	5.00	8.44	46.19	44.31	48.00	51.00	40	1.88	1 3/4	0.62
46	57.50	5.06	5.12	8.75	48.38	46.31	50.00	53.75	36	2.00	1 7/8	0.62
48	59.50	5.06	5.31	8.81	50.31	48.31	52.25	55.75	40	2.00	1 7/8	0.62
50	61.50	5.44	5.50	9.25	52.38	50.31	54.25	57.75	44	2.00	1 7/8	0.62
52	63.50	5.62	5.68	9.56	54.44	52.31	56.25	59.75	48	2.00	1 7/8	0.62
54	65.88	5.38	5.88	9.44	56.50	54.31	58.25	62.12	48	2.00	1 7/8	0.62
56	69.50	6.06	6.18	10.56	58.81	56.31	60.50	65.00	36	2.38	2 1/4	0.69
58	71.94	6.06	6.38	10.81	60.94	58.31	62.75	67.44	40	2.38	2 1/4	0.69
60	73.94	5.94	6.56	10.69	62.94	60.31	65.00	69.44	40	2.38	2 1/4	0.69

METHOD OF DESIGNATING LOCATION OF AUXILIARY CONNECTIONS WHEN SPECIFIED

TABLE 22

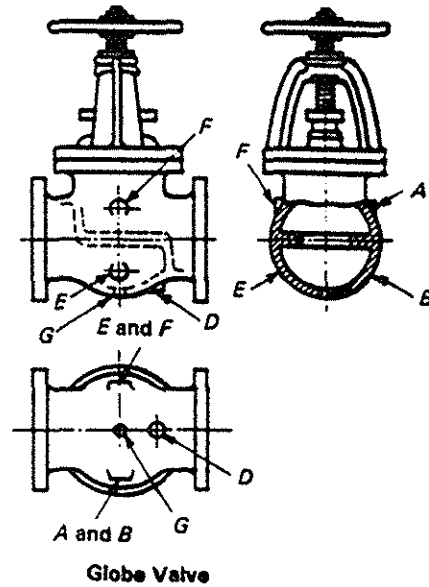
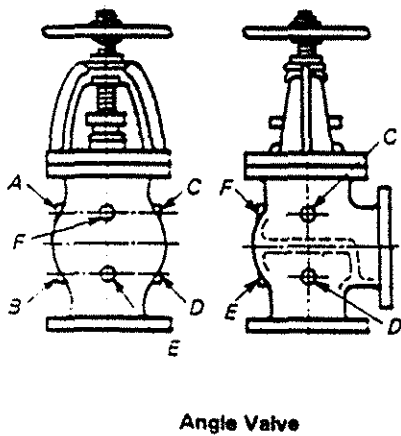
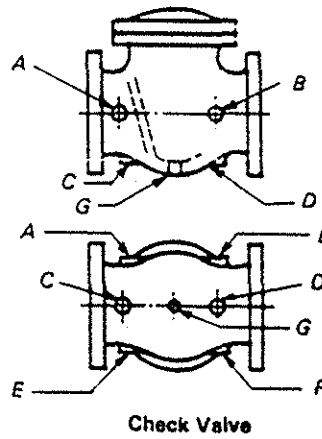
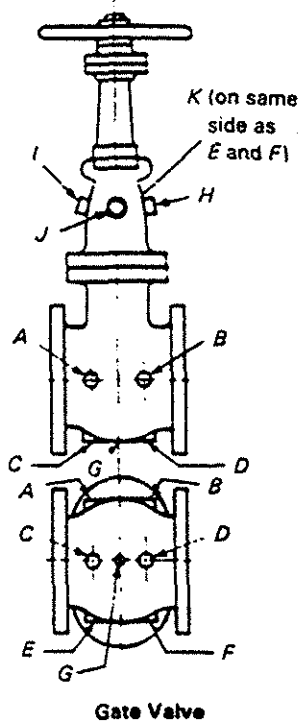

GENERAL NOTE:

The above sketches represent valves with symmetrical shapes. Sketches are illustrative only and do not imply design.

FLOW DESIGN RECOMMENDATIONS

- (1) **SWING CHECK VALVES-** Minimum ½ psi differential pressure across valve to maintain proper "full open" position.
- (2) **LIFT CHECK AND NON-RETURN VALVES-** Minimum 2 psi differential pressure across valve to maintain proper "full open" position.
- (3) **RECOMMENDED MAXIMUM FLOW VELOCITIES (APPROXIMATE)**

<u>VALVE SIZE</u>	<u>WATER (FT/MIN)</u>	<u>SATURATED STEAM (FT/MIN)</u>	<u>SUPERHEATED STEAM (FT/MIN)</u>
3" and UNDER	1200	7200	9000
4	1200	8800	11000
6	1620	10400	13000
8	1860	12000	15000
10	2100	14400	18000
12	2220	15200	19000
14	2400	16000	20000
16	2400	17600	22000
18	2400	19200	24000
20" and LARGER	2400	20800	26000

FLOW COEFFICIENT (C_v) VALUES

TABLE 23

CARBON STEEL

CLASS	GATE		GLOBE		CHECK (1)	
	150	300	150	300	150	300
FIG. NO.	1503	3003	1531	3031	1561	3061
VALVE SIZE						
2	240	240	40	40	75	75
2 ½	390	390	65	65	120	120
3	560	560	95	95	170	170
4	1020	1020	175	175	315	315
6	2440	2440	410	410	760	760
8	4500	4500	760	760	1390	1390
10	6900	6900	1190	1190	2170	2170
12	10400	10400	1780	1780	3250	3250

CORROSION RESISTANT STEEL

CLASS	GATE		GLOBE		CHECK (1)	
	150/200	300	150/200	300	150/200	300
FIG. NO.	2490/2491	2466/2467	2474/2475	2446/2447	2341/2342	2345/2346
VALVE SIZE	2494/2495 2456		2629		2633	
2	240	240	40	40	75	75
2 ½	350	350	65	65	120	120
3	510	510	95	95	170	170
4	960	960	175	175	315	315
6	2340	2340	410	410	760	760
8	4500	4500	760	760	1390	1390
10	6900	6900	1190	1190	2170	2170
12	10400	10400	1780	1780	3250	3250

NOTES: 1. 5 DEG. SWING CHECK VALVES

COMPARISON CHART OF VALVE SIZE/NOMINAL PIPE SIZE

TABLE 24

<u>METRIC NOMINAL SIZE</u> (DN)	<u>ENGLISH NOMINAL SIZE</u> (NPS)
8	1/4
10	3/8
15	1/2
20	3/4
25	1
32	1-1/4
40	1-1/2
50	2
65	2-1/2
80	3
100	4
150	6
200	8
250	10
300	12
350	14
400	16
450	18
500	20
600	24

CONVERSION FACTORS

	TO CONVERT FROM	TO	MULTIPLY BY
LENGTH	INCHES(IN)	MILLIMETERS(MM)	25.4
	INCHES(IN)	CENTIMETERS(CM)	2.54
	INCHES(IN)	FEET(FT)	0.0833
	MILLIMETERS(MM)	INCHES(IN)	0.03937
	CENTIMETERS(CM)	INCHES(IN)	0.3937
	FEET(FT)	INCHES(IN)	12
WEIGHT	POUNDS(LB)	KILOGRAMS(KG)	0.4536
	POUNDS(LB)	NEWTONS(N)	4.448
	KILOGRAMS(KG)	POUNDS(LB)	2.205
	NEWTONS(N)	POUNDS(LB)	0.2248
PRESSURE*	PSI	KILOGRAMS/M ²	703
	PSI	KILOGRAMS/CM ²	0.0703
	PSI	KILOGRAMS/MM ²	0.000703
	PSI	BAR	0.0689
	PSI	ATMOSPHERE	0.0680
	PSI	KILOPASCAL	6.895
	PSI	MEGAPASCAL	0.006895
	PSI	NEWTON/MM ²	0.006895
	PSI	IN.WATER**	27.68
	PSI	FT.WATER**	2.307
	PSI	IN.MERCURY**	2.036
	PSI	PSF	144
	KILOGRAMS/M ²	PSI	0.001422
	KILOGRAMS/CM ²	PSI	14.22
	KILOGRAMS/MM ²	PSI	1422
	BAR	PSI	14.5
	ATMOSPHERE	PSI	14.7
	KILOPASCAL	PSI	0.145
	MEGAPASCAL	PSI	145
	NEWTON/MM ²	PSI	145
IN.WATER**	PSI	0.0361	
FT.WATER**	PSI	0.433	
IN.MERCURY**	PSI	0.491	
PSF	PSI	0.00694	
AREA	SQ.INCH(IN ²)	SQ.CENTIMETERS(CM ²)	6.452
	SQ.CENTIMETERS(CM ²)	SQ.INCH(IN ²)	0.155

TEMPERATURE

TO CONVERT FROM DEGREES CENTIGRADE (C) TO DEGREES FAHRENHEIT (F): $F=1.8^{\circ}C+32$

TO CONVERT FROM FAHRENHEIT (F) TO DEGREES CENTIGRADE (C): $C=0.556^{\circ}(F-32)$

NOTE: MOST FACTORS ARE ROUNDED OFF AND NOT EXACT CONVERSIONS.

* PSI = POUNDS PER SQUARE INCH AND PSF = POUNDS PER SQUARE FOOT.

**WATER AT 60F. MERCURY AT 32F.

MEASUREMENT EQUIVALENTS

FRACTION		DECIMAL	MILLIMETERS
	1/64	.01563	.3969
	1/32	.03125	.7938
		.03937	1.0000
	3/64	.04688	1.1906
1/16		.06250	1.5875
	5/64	.07813	1.9844
		.07874	2.0000
	3/32	.09375	2.3813
	7/64	.10938	2.7781
		.11811	3.0000
1/8		.12500	3.1750
	9/64	.14063	3.5719
	5/32	.15625	3.9688
		.15748	4.0000
	11/64	.17188	4.3656
3/16		.18750	4.7625
		.19685	5.0000
	13/64	.20313	5.1594
	7/32	.21875	5.5563
	15/64	.23438	5.9531
		.23622	6.0000
1/4		.25000	6.3500
	17/64	.26563	6.7469
		.27559	7.0000
	9/32	.28125	7.1438
	19/64	.29688	7.5406
5/16		.31250	7.9375
		.31496	8.0000
	21/64	.32813	8.3344
	11/32	.34375	8.7313
		.35433	9.0000
	23/64	.35938	9.1281
3/8		.37500	9.5250
	25/64	.39063	9.9219
		.39370	10.0000
	13/32	.40625	10.3188
	27/64	.42188	10.7156
		.43307	11.0000
7/16		.43750	11.1125
	29/64	.45313	11.5094
	15/32	.46875	11.9063
		.47244	12.0000
	31/64	.48438	12.3031
1/2		.50000	12.7000

FRACTION		DECIMAL	MILLIMETERS
		.51181	13.0000
	33/64	.51563	13.0969
	17/32	.53125	13.4938
	35/64	.54688	13.8906
		.55118	14.0000
9/16		.56250	14.2875
	37/64	.57813	14.6844
		.59055	15.0000
	19/32	.59375	15.0813
	39/64	.60938	15.4781
5/8		.62500	15.8750
		.62992	16.0000
	41/64	.64063	16.2719
	21/32	.65625	16.6688
		.66929	17.0000
	43/64	.67188	17.0656
11/16		.68750	17.4625
	45/64	.70313	17.8594
		.70866	18.0000
	23/32	.71875	18.2563
	47/64	.73438	18.6531
		.74803	19.0000
3/4		.75000	19.0500
	49/64	.76563	19.4469
	25/32	.78125	19.8438
		.78740	20.0000
	51/64	.79688	20.2406
13/16		.81250	20.6375
		.82677	21.0000
	53/64	.82813	21.0344
	27/32	.84375	21.4313
	55/64	.85938	21.8281
		.86614	22.0000
7/8		.87500	22.2250
	57/64	.89063	22.6219
		.90551	23.0000
	29/32	.90625	23.0188
	59/64	.92188	23.4156
15/16		.93750	23.8125
		.94488	24.0000
	61/64	.95313	24.2094
	31/32	.96875	24.6063
		.98425	25.0000
	63/64	.98438	25.0031
1		1.00000	25.40000

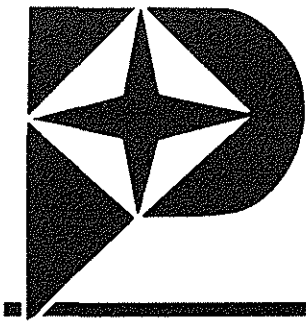

POWELL VALVES

Dependable Valves Since 1846



CERTIFIED TO ISO 9001 QUALITY STANDARDS

THE WM. POWELL COMPANY
2503 Spring Grove Avenue
CINCINNATI, OHIO 45214-1771, U.S.A.

TERMS AND CONDITIONS

1. This catalog supersedes all previous issues.
2. For prices refer to current Powell Price Lists.
3. Prices, materials and designs are subject to change without notice.
4. Powell quotations and/or contracts do not include any municipal, state or Federal sales, excise, use, occupational or other taxes, and any such tax, if paid by us, will be charged to the purchaser.
5. Refer to current price lists for TERMS applying to sales of our several types or valves and accessories. "However if the terms as set forth in current price lists, extend a cash discount for prompt payment, such a discount does not apply to motor operators and other equipment or accessories manufactured by others.
6. All quotations, contracts, orders or agreements are subject to approval and/or acceptance by the Main office.
7. Orders are not cancelable except with our consent, and then upon terms indemnifying us against all loss.
8. No goods may be returned without our written permission and we assume no responsibility for any goods returned without such permission. On standard items a minimum charge of 35% of the invoiced price will be made to cover the cost of handling and reconditioning such returned goods. Special valves are not returnable.
9. Order for special goods must be in writing and accompanied with detailed prints and/or set of specifications, unless specifications on the order are definite and complete. Such orders cannot be cancelled unless customer agrees to pay for all work including engineering, completed up to the time of cancellation.
10. We are not responsible for delays in delivery or defaults in completing a contract due to strikes, work stoppages, fires, floods, accident, inability to obtain materials, fuel, transportation or other causes beyond our control.
11. All claims for shortages, corrections or deductions must be made within 10 days after

receipt of goods. Responsibility for goods lost or damaged in transit, rests with carrier, and claims should be filed with the carrier by the consignee.

12. We reserve the right to correct clerical or stenographic errors in quotations, orders, invoices and other contracts, agreement or documents.
13. Any order with a total value of less than \$200.00 will be billed at this minimum charge of \$200.00.
14. The following warranties are made in lieu of warranties of merchantability or fitness for any particular purpose, and in lieu of all other warranties expressed or implied, and no other warranty is made or authorized to be made:

The Wm. Powell Company guarantees its product against defects in material and workmanship for a period of up to one (1) year from date of shipment, where such product is used in a service for which it is recommended.

The Wm. Powell Company's sole obligation and the exclusive remedy under the aforesaid warranty or under any other warranty implied by law as to merchantability or fitness of use is limited to (1) repair of the product, F.O.B. factory, OR (2) replacement of any part or parts proven defective in material or workmanship, OR (3) refund of the purchase price. The choice of said remedies shall be determined by The Wm. Powell Company in its sole discretion. The Buyer shall permit the Wm. Powell Company to inspect the product so that it may determine its obligation, if any, hereunder. Upon settlement of its obligation, if any, under this warranty, The Wm. Powell Company at its option, shall be entitled to the return of the defective product or part(s) (transportation to be prepaid).

The Wm. Powell Company is NOT responsible for any other damages, whatsoever, in connection with replacement, repair, or refund as set forth above, said obligations and remedies to be the sole warranty given hereunder.

No warranty shall apply to any product which is *modified or changed in design or function after leaving the The Wm. Powell Company's factory.*

THE WM. POWELL COMPANY

Pioneers in Valve Manufacturing

Since 1846

The Wm Powell Company's products include a wide variety of valves in Bronze Iron Steel and Corrosion Resistant Alloys for class 125 to Class 2500 pressure service. Our experience as a pioneer in the development of industrial valves since 1846 encompasses over a century of craftsmanship and valve know how. Through modern engineering laboratory research and testing facilities The Wm Powell Co has been able to keep pace with the changing times. Our on-going program is a long term commitment to the valve industry and is poised for significant future growth.

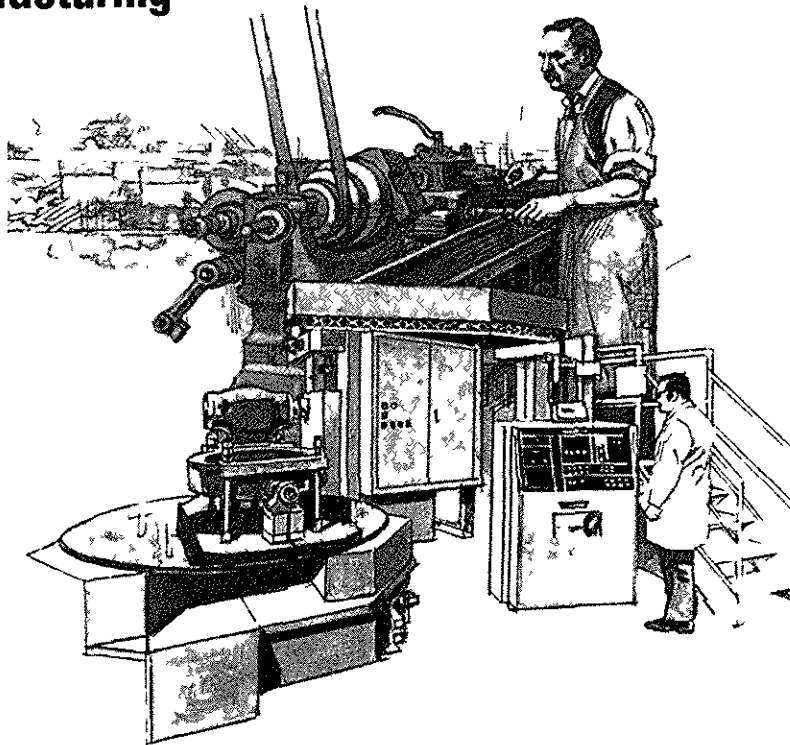

Powell has developed very special valve designs which are made for various industries. All materials are under constant rigid quality control with scientific equipment in our physical chemical testing and clean room laboratories they can be depended upon to effectively resist corrosion erosion heat and wear. Through combined efforts and 'know how' of Powell Metallurgists Chemists Engineers and Foundrymen Powell has available a large selection of metals and alloys for solving practically any flow control or fugitive emission problem. If confronted with an unusual and difficult valve problem they will help you solve it by carefully analyzing your valve requirements then by recommending not only the type of valves but the metals or alloys from which they should be made to obtain most satisfactory results. Powell Valves are manufactured at various locations in the U S A and Worldwide.

CORPORATE OFFICES THE WM. POWELL COMPANY

2503 Spring Grove Avenue
Cincinnati Ohio 45214 U.S.A.
Phone (513) 852 2000
FAX (513) 852 2997
www.powellvalves.com
wmpowell@powellvalves.com

FOUNDRY PLANT 1
Cincinnati Ohio

PLANT 2
Cincinnati Ohio

PLANT 6
Orangeburg South Carolina

PLANT 8
Manning South Carolina



Dependable Valves Since 1846

PLANT 3
Bistrita Romania

PLANT 4
Taipei Taiwan R.O.C.

PLANT 7
Seoul Korea