

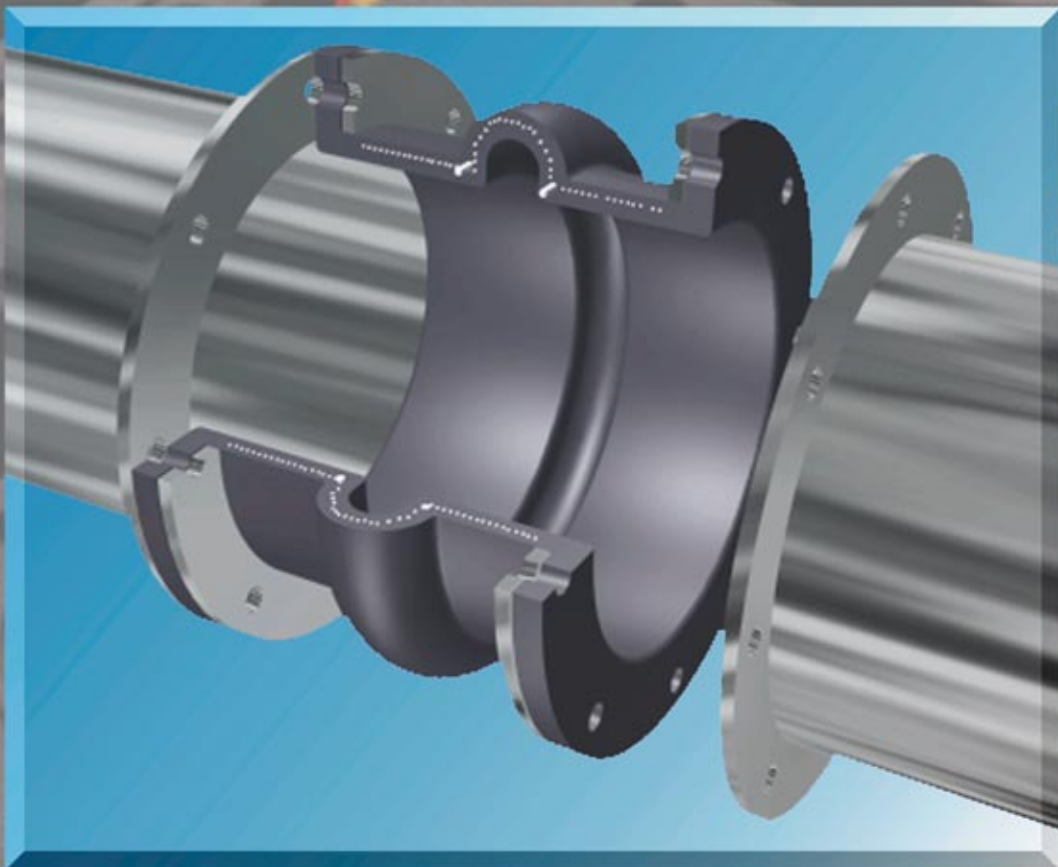

# Series 230



*The Expansion Joint People*

# PROCO

## SERIES

# 230/220

### spool type wide arch rubber expansion joints



PROCO Series 230, Styles 231, 232, & 233 Non-Metallic Expansion Joints are designed for tough, demanding industrial applications, as found in: Chemical/Petrochemical Plants, Industrial Process Piping Systems, Marine Services, Power Generation Plants, Pulp/Paper Plants, Steel Mills, Water/Wastewater and Pollution Control Systems. Installed next to mechanical equipment or between the anchor points of a piping system, specify the PROCO Series 230 to: (1) Absorb Pipe Movement/Stress, (2) Reduce System Noise, (3) Isolate Mechanical Vibration, (4) Compensate Alignment/Offset, (5) Eliminate Electrolysis, (6) Protect Against Start-Up Surge Forces. Our history in the manufacture of expansion joints dates back to 1930. When you need an engineered rubber expansion joint solution to a piping problem, call PROCO!

**Series 230 Replaces Series 220.** The new and improved PROCO Series 230 replaces the PROCO Series 220 rubber expansion joints. (Series 220 products will be available only in short neutral lengths.) This new hand-built product has been completely re-engineered to provide improved strength, flexibility, movement and spring rate capabilities. Manufactured utilizing tire industry technology, the Series 230 combines woven nylon fabric and nylon tire cord into a fabric matrix bonded with elastomer and reinforced with wire to create a product with greater operating performance. The nomenclature for the new PROCO Series 230 is as follows:

- Single Arch Series 230, Style 231
- Double Arch Series 230, Style 232
- Triple Arch Series 230, Style 233

**Greater Movements With A Lower/Wider Arch Profile.** The movements for the PROCO Series 230 exceed the specification of the Fluid Sealing Association's Rubber Expansion Joint Division Technical Handbook (Sixth Edition), Table V. Due to a new and improved lower, wider profile arch, more axial compression and axial extension coupled with lateral misalignment, angular and torsional movements can be obtained without increasing the face-to-face requirements. Installation of the Series 230 in a piping system will negate the need for long and expensive multi-arch products. For greater movements based on re-engineering and new product construction, specify the PROCO Series 230.

**Less Turbulence Or Material Entrapment.** The PROCO 230 Series molded integral flange joins the body at a true 90° angle. Our product will install snug against the mating pipe flange without voids. The flange body of the rubber expansion joint is difficult to form and many manufacturers radius the edge angles. The resulting void between the mating flange and the edge angle can create flow turbulence and allow for material entrapment or bacterial growth. You can avoid these problems by specifying PROCO Series 230 rubber expansion joints.

**Chemical Or Abrasive Service Capability.** Expensive metallic designs for chemical service can be replaced with the more cost-effective PROCO Series 230. Built with low-cost chemical resistant elastomers, such as Chlorobutyl, DuPont Dow Elastomer Hypalon® rubber, EPDM, Natural, Neoprene and Nitrile, assures an expansion joint compatible with fluid being pumped or piped (See Table 1). When handling abrasive products such as any solids or slurries, Natural or Neoprene filled arch products should be specified. Please refer to PROCO "Chemical to Elastomer Guide" for recommendations on elastomer chemical compatibility for piping processes.

**Table 1: Available Styles • Materials • Temperatures**

For Specific Elastomer Recommendations, See: PROCO™ "Chemical To Elastomer Guide"						
PROCO Style Numbers		Cover <sup>2</sup> Elastomer	Tube Elastomer	Maximum Operating Temp. °F (°C)	Branding Label Color	F.S.A. Material Class
Filled Arch (Single) <sup>6</sup>	Open Arch (Single) <sup>6</sup>					
FA231/BB	231/BB	Butyl <sup>4</sup>	Butyl <sup>4</sup>	250° (121°)	Black	STD. III
FA231/EE	231/EE	EPDM	EPDM	250° (121°)	Red	STD. III
FA231/NH	231/NH	Neoprene	Hypalon <sup>1</sup>	212° (100°)	Green	STD. II
FA231/NN <sup>5</sup>	231/NN <sup>5</sup>	Neoprene	Neoprene	225° (107°)	Blue	STD. II
FA231/NP	231/NP	Neoprene	Nitrile	212° (100°)	Yellow	STD. II
FA231/NR	231/NR	Neoprene	Natural	180° (68°)	White	STD. I

Notes: 1. Hypalon is a registered trademark of DuPont Dow Elastomers.  
 2. Expansion joint "cover" can be coated with Hypalon® on special order.  
 3. All products are reinforced with steel and fabric materials.  
 4. The term "butyl" is synonymous with chlorobutyl (CIIR).  
 5. Styles FA231, FA232, FA233 and styles 231, 232, 233 meet all requirements of U.S.C.G.  
 6. Style numbers above reflect one arch. Products are also available in Styles 232 and 233.

**Exclusive Sealing Bead Means A Quick Seal.** PROCO has built an "O-Ring" on each flange face of the Series 230. Available only from PROCO, the Series 230 seals faster with less torque at installation. For these exclusive features, specify the PROCO Series 230 rubber expansion joints.

**Specifications Met.** PROCO has assigned conservative pressure ratings to the Series 230 rubber expansion joints. The ratings, however, meet the requirements of the Fluid Sealing Association's Rubber Expansion Joint Division Technical Handbook (Sixth Edition), Series C. The pressure ratings for the Series 230 rubber expansion joints have been fully tested and are based on a minimum four-to-one safety factor. For pressure protection with confidence, specify the PROCO Series 230.

**Tested Force Pound And Spring Rate Tables.** The Series 230 rubber expansion joints are in accordance with and/or lower than the guidelines for spring rate data as listed in the Fluid Sealing Association's Rubber Expansion Joint Division Technical Handbook (Sixth Edition), Table V. Due to a lower, wider arch profile, the PROCO Series 230 will provide more flexibility than conventional spool-type rubber expansion joints. In addition, the lower/wider arch profile coupled with a modified radial tire cord construction will result in lower flange forces. Lower resultant forces mean reduced stress of related piping system components. PROCO is currently testing each rubber expansion joint size and will list actual test data as opposed to listing hypothetical data normally associated with spring rate tables.

**Absorbs Vibration • Noise • Shock.** The PROCO Series 230 quiet-operating rubber expansion joints are a replacement for "sound transmitting" metallic expansion joints. Sound loses energy traveling axially through an expansion joint. Water hammer, pumping impulses, water-borne noises and other forms of strain-stress-shock are cushioned and absorbed by the molded elastomer expansion joint, not related to piping. Install the Series 230 in a system to reduce vibration transmission when the piping section beyond the expansion joint is anchored or sufficiently rigid. For quiet, stress-free systems, specify the PROCO Series 230.

**Wide Service Range With Low Cost.** Engineered to operate up to 200 PSIG or up to 250°F, the PROCO Series 230 can be specified for a wide range of piping system requirements. Compared to competitive products, you will invest less money when specifying the engineered design and industrial quality of the PROCO Series 230.

**Large Inventory Means Same-Day Shipment.** We maintain the largest inventory of elastomeric expansion joints in the world. Every size cataloged up to 72" is in stock in a variety of elastomers. We can ship the products you need when you need them! In fact, when it comes to rubber expansion joints, **if PROCO doesn't have them in stock ... nobody does!**

**Information • Ordering • Pricing • Delivery.** Day or night, weekends and holidays ... the PROCO phones are monitored 24 hours around the clock. When you have a question, you can call us.

Toll-Free Phone ..... 800 / 344-3246 USA/CANADA  
 International Calls .... 209 / 943-6088  
 Fax ..... 209 / 943-0242  
 E-mail ..... sales@procoproducts.com  
 Web Site ..... www.procoproducts.com  
 Weekday office hours are 5:30 a.m. to 5:15 p.m. Pacific Time.



**Protecting Piping And Equipment Systems From Stress/Motion**

# PROCO

STYLE

# 231/221

single wide arch spool type  
rubber expansion joints



Table 2: Sizes • Movements • Forces • Weights

See Notes Page 7

EXPANSION JOINT SIZE Nom. I.D. x Inch / (mm)	NEUTRAL LENGTH Inch / (mm)	EXPANSION JOINT STYLE	231 / 221 Movement Capability: From Neutral Position					Spring Rate Capability Based on 1" of Movement at Zero Pressure Conditions					Operating <sup>4</sup> Conditions			Weights <sup>5</sup> lbs / (kgs)		
			Axial Compression Inch / (mm)	Axial Extension Inch / (mm)	Lateral Deflection Inch / (mm)	Angular <sup>1</sup> Deflection Degrees	Torsional <sup>2</sup> Rotation Degrees	Force lbs. per 1" rated Compression	Force lbs. per 1" rated Extension	Force lbs. per 1" rated Lateral Deflection	Force ft.-lbs. per 1" rated Angular	Thrust Factor <sup>3</sup> Inz / (cm2)	Positive PSIG/ (Bar)	Vacuum Inches of Hg/ (mm of Hg)	Expansion Joint Assembly	Retaining Ring Set	Control <sup>6</sup> Rod Assembly	
																		Force lbs. per 1" rated Compression
1 1.25 1.5	(25)	6 (152)	231	1.2 (30)	0.6 (15)	0.6 (15)	50.4	2.0	U N D E R C U R R E N T T E S T I N G	5.12 (33)	200 (14.0)	26 (660)	2.0 (0.8)	2.0 (0.8)	2.3 (1.0)			
	(32)	6 (152)	231	1.2 (30)	0.6 (15)	0.6 (15)	43.1	2.0		6.20 (40)	200 (14.0)	26 (660)	2.5 (1.1)	2.5 (1.1)	2.3 (1.0)			
	(40)	6 (152)	231	1.2 (30)	0.6 (15)	0.6 (15)	38.1	2.0		7.44 (48)	200 (14.0)	26 (660)	3.0 (1.4)	2.5 (1.1)	2.3 (1.0)			
2	(50)	6 (152)	231	1.4 (35)	0.7 (18)	0.6 (15)	34.2	2.0		U N D E R C U R R E N T T E S T I N G	12.40 (80)	200 (14.0)	26 (660)	4.0 (1.8)	4.0 (1.8)	2.8 (1.3)		
		7 (178)	231															
		8 (203)	231															
		9 (229)	231															
		10 (254)	231															
2.5	(65)	6 (152)	231	1.4 (35)	0.7 (18)	0.6 (15)	27.6	2.0			U N D E R C U R R E N T T E S T I N G	15.66 (101)	200 (14.0)	26 (660)	4.5 (2.0)	4.5 (2.0)	2.8 (1.3)	
		7 (178)	231															
		8 (203)	231															
		9 (229)	231															
		10 (254)	231															
3	(80)	6 (152)	231	1.4 (35)	0.7 (18)	0.6 (15)	23.0	2.0	U N D E R C U R R E N T T E S T I N G			19.38 (125)	200 (14.0)	26 (660)	5.5 (2.5)	5.5 (2.5)	2.8 (1.3)	
		7 (178)	231															
		8 (203)	231															
		9 (229)	231															
		10 (254)	231															
3.5	(90)	6 (152)	221	0.6 (15)	0.3 (8)	0.56 (14)	9.0	2.0		U N D E R C U R R E N T T E S T I N G		23.18 (150)	200 (14.0)	26 (660)	6.0 (2.7)	6.0 (2.7)	2.8 (1.3)	
		7 (178)	221															
		8 (203)	221															
		9 (229)	221															
		10 (254)	221															
4	(100)	6 (152)	231	1.4 (35)	0.7 (18)	0.6 (15)	18.8	2.0			U N D E R C U R R E N T T E S T I N G	27.90 (180)	200 (14.0)	26 (660)	8.0 (3.6)	8.0 (3.6)	2.8 (1.3)	
		7 (178)	231															
		8 (203)	231															
		9 (229)	231															
		10 (254)	231															
		12 (305)	231															

See Notes Page 7

# 231/221 continued



**Table 2: Sizes • Movements • Forces • Weights**

See Notes Page 7

EXPANSION JOINT SIZE Nom. I.D. x Inch / (mm)	NEUTRAL LENGTH Inch / (mm)	EXPANSION JOINT STYLE	231 / 221 Movement Capability: From Neutral Position					Spring Rate Capability Based on 1" of Movement at Zero Pressure Conditions					Operating <sup>4</sup> Conditions		Weights <sup>5</sup> lbs / (kgs)				
			Axial Compression Inch / (mm)	Axial Extension Inch / (mm)	Lateral Deflection Inch / (mm)	Angular <sup>1</sup> Deflection Degrees	Torsional <sup>2</sup> Rotation Degrees	Force lbs per 1" rated Compression	Force lbs per 1" rated Extension	Force lbs per 1" rated Lateral Deflection	Force ft-lbs per 1" rated Angular	Thrust Factor <sup>3</sup> Inz / (cm2)	Positive PSIG/ (Bar)	Vacuum Inches of Hg/ (mm of Hg)	Expansion Joint Assembly	Retaining Ring Set	Control <sup>6</sup> Rod Assembly		
5	(125)	6 (152)	231																
		7 (178)	231																
		8 (203)	231	1.4	0.7	0.6	15.2	2.0			38.13	190	26	9.0	8.5	4.0			
		9 (229)	231	(35)	(18)	(15)					(246)	(13.0)	(660)	(4.1)	(3.9)	(1.8)			
		10 (254)	231																
		12 (305)	231																
6	(150)	6 (152)	231																
		7 (178)	231																
		8 (203)	231	1.4	0.7	0.6	12.8	2.0			49.91	190	26	11.0	9.5	4.0			
		9 (229)	231	(35)	(18)	(15)					(322)	(13.0)	(660)	(5.0)	(4.3)	(1.8)			
		10 (254)	231																
		12 (305)	231																
8	(200)	6 (152)	231																
		7 (178)	231																
		8 (203)	231																
		9 (229)	231	1.4	0.7	0.6	9.7	2.0			77.97	190	26	15.0	14.5	8.0			
		10 (254)	231	(35)	(18)	(15)					(503)	(13.0)	(660)	(6.8)	(6.6)	(3.6)			
		12 (305)	231																
10	(250)	6 (152)	221	0.7	0.4	0.5	4.1	2.0			116.97	190	26	23.0	17.0	10.0			
		7 (178)	221	(18)	(10)	(13)				(755)	(13.0)	(660)	(10.4)	(7.7)	(4.5)				
		8 (203)	231																
		9 (229)	231																
10	(250)	10 (254)	231	1.6	0.8	0.8	9.1	2.0			119.97	190	26	23.0	17.0	10.0			
		12 (305)	231	(40)	(20)	(20)				(774)	(13.0)	(660)	(10.4)	(7.7)	(4.5)				
		14 (356)	231																
		6 (152)	221	0.7	0.4	0.5	3.4	2.0			157.74	190	26	26.5	24.5	10.0			
12	(300)	7 (178)	221	(17)	(10)	(13)				(1018)	(13.0)	(660)	(12.0)	(11.0)	(4.5)				
		8 (203)	231																
		9 (229)	231																
		10 (254)	231	1.6	0.8	0.8	7.6	2.0			161.18	190	26	34.0	24.5	10.0			
		12 (305)	231	(40)	(20)	(20)				(1045)	(13.0)	(660)	(15.4)	(11.0)	(4.5)				
		14 (356)	231																
14	(350)	8 (203)	231																
		9 (229)	231																
		10 (254)	231	1.6	0.8	0.8	6.5	2.0			210.18	130	26	40.0	27.0	12.0			
		12 (305)	231	(40)	(20)	(20)				(1356)	(9.0)	(660)	(18.1)	(12.3)	(5.4)				
14 (356)	231																		

See Notes Page 7

Table 2: Sizes • Movements • Forces • Weights														See Notes Page 7					
EXPANSION JOINT SIZE Nom. I.D. X Inch / (mm)	NEUTRAL LENGTH Inch / (mm)	EXPANSION JOINT STYLE	231 / 221 Movement Capability: From Neutral Position					Spring Rate Capability Based on 1" of Movement at Zero Pressure Conditions					Operating <sup>4</sup> Conditions		Weights <sup>5</sup> lbs / (kgs)				
			Axial Compression Inch / (mm)	Axial Extension Inch / (mm)	Lateral Deflection Inch / (mm)	Angular, <sup>1</sup> Deflection Degrees	Torsional, <sup>2</sup> Rotation Degrees	Force lbs per 1" rated Compression	Force lbs per 1" rated Extension	Force lbs per 1" rated Lateral Deflection	Force lbs per 1" rated Angular	Thrust Factor <sup>3</sup> Inz / (cm2)	Positive PSIG/ (Bar)	Vacuum Inches of Hg/ (mm of Hg)	Expansion Joint Assembly	Retaining Ring Set	Control <sup>6</sup> Rod Assembly		
16	(400)	8 (203)	231																
		9 (229)	231																
		10 (254)	231	1.6 (40)	0.8 (20)	0.8 (20)	5.7	2.0			264.74 (1708)	115 (8.0)	26 (660)	47.0 (21.3)	33.5 (15.2)	15.0 (6.8)			
		12 (305)	231																
		14 (356)	231																
18	(450)	8 (203)	231																
		9 (229)	231																
		10 (254)	231	1.6 (40)	0.8 (20)	0.8 (20)	5.1	2.0			325.50 (2100)	115 (8.0)	26 (660)	56.0 (25.4)	34.0 (15.5)	16.0 (7.2)			
		12 (305)	231																
		14 (356)	231																
20	(500)	8 (203)	231																
		9 (229)	231																
		10 (254)	231	1.6 (40)	0.8 (20)	0.8 (20)	5.7	2.0			392.62 (2533)	115 (8.0)	26 (660)	67.0 (30.4)	38.0 (17.3)	16.0 (7.2)			
		12 (305)	231																
		14 (356)	231																
22	(550)	8 (203)	221	0.8 (20)	0.5 (13)	0.5 (13)	2.6	2.0			483.08 (3117)	100 (7.0)	26 (660)	70.0 (31.8)	44.0 (20.0)	19.0 (8.6)			
		9 (229)	221																
22	(550)	10 (254)	231																
		12 (305)	231	2.0 (51)	1.0 (25)	1.0 (25)	5.2	2.0			481.12 (3104)	100 (7.0)	26 (660)	70.0 (31.8)	44.0 (20.0)	19.0 (8.6)			
		14 (356)	231																
24	(600)	8 (203)	221	0.8 (20)	0.5 (13)	0.5 (13)	2.3	2.0			562.82 (3631)	100 (7.0)	26 (660)	79.0 (35.8)	48.0 (21.8)	19.0 (8.6)			
		9 (229)	221																
24	(600)	10 (254)	231																
		12 (305)	231	2.0 (51)	1.0 (25)	1.0 (25)	4.8	2.0			562.03 (3626)	100 (7.0)	26 (660)	79.0 (35.8)	48.0 (21.8)	20.0 (9.0)			
		14 (356)	231																
26	(650)	10 (254)	231																
		12 (305)	231	2.0 (51)	1.0 (25)	1.0 (25)	4.4	2.0			649.14 (4188)	90 (6.0)	26 (660)	100.0 (45.4)	51.0 (23.1)	20.0 (9.0)			
		14 (356)	231																
28	(700)	10 (254)	231																
		12 (305)	231	2.0 (51)	1.0 (25)	1.0 (25)	4.1	2.0			742.45 (4790)	90 (6.0)	26 (660)	102.0 (46.3)	55.0 (25.0)	28.0 (12.6)			
30	(750)	9 (229)	221	0.9 (23)	0.6 (15)	0.5 (13)	2.2	2.0			798.58 (5152)	90 (6.0)	26 (660)	117.0 (53.1)	63.0 (28.6)	29.5 (13.3)			
		10 (254)	231																
30	(750)	12 (305)	231	2.0 (51)	1.0 (25)	1.0 (25)	3.8	2.0			842.27 (5434)	90 (6.0)	26 (660)	117.0 (53.1)	63.0 (28.6)	29.5 (13.3)			
		14 (356)	231																

U  
N  
D  
E  
R  
  
C  
U  
R  
R  
E  
N  
T  
  
T  
E  
S  
T  
I  
N  
G

Table 2: Sizes • Movements • Forces • Weights														See Notes Page 7					
EXPANSION JOINT SIZE Nom. I.D. X Inch / (mm)	NEUTRAL LENGTH Inch / (mm)	EXPANSION JOINT STYLE	231 / 221 Movement Capability: From Neutral Position						Spring Rate Capability Based on 1" of Movement at Zero Pressure Conditions					Operating <sup>4</sup> Conditions		Weights <sup>5</sup> lbs / (kgs)			
			Axial Compression Inch / (mm)	Axial Extension Inch / (mm)	Lateral Deflection Inch / (mm)	Angular <sup>1</sup> Deflection Degrees	Torsional <sup>2</sup> Rotation Degrees	Force lbs per 1" rated Compression	Force lbs per 1" rated Extension	Force lbs per 1" rated Lateral Deflection	Force lb-lbs per 1" rated Angular	Thrust Factor <sup>3</sup> Inz / (cmz)	Positive PSIG/ (Bar)	Vacuum Inches of Hg/ (mm of Hg)	Expansion Joint Assembly	Retaining Ring Set	Control <sup>6</sup> Rod Assembly		
32 (800)	10 (254)	231																	
	12 (305)	231	2.0 (51)	1.0 (25)	1.0 (25)	3.6	2.0				948.29 (6118)	90 (6.0)	26 (660)	120.0 (54.4)	68.0 (30.8)	33.0 (14.9)			
34 (850)	10 (254)	231																	
	12 (305)	231	2.0 (51)	1.0 (25)	1.0 (25)	3.4	2.0				1060.51 (6842)	90 (6.0)	26 (660)	122.0 (55.3)	72.0 (32.7)	43.0 (19.5)			
36 (900)	10 (254)	231																	
	12 (305)	231	2.0 (51)	1.0 (25)	1.0 (25)	3.2	2.0				1179.09 (7607)	90 (6.0)	26 (660)	143.0 (64.9)	76.0 (34.5)	43.0 (19.5)			
38 (950)	10 (254)	231																	
	12 (305)	231	2.0 (51)	1.0 (25)	1.0 (25)	3.0	2.0				1303.86 (8412)	90 (6.0)	26 (660)	162.0 (73.5)	86.0 (39.0)	43.0 (19.5)			
40 (1000)	10 (254)	231																	
	12 (305)	231	2.0 (51)	1.0 (25)	1.0 (25)	2.9	2.0				1434.99 (9258)	90 (6.0)	26 (660)	173.0 (78.5)	100.0 (45.5)	43.0 (19.5)			
42 (1050)	12 (305)	231	2.4 (61)	1.2 (30)	1.1 (28)	3.3	2.0				1628.28 (10505)	80 (5.5)	26 (660)	193.0 (87.5)	100.0 (45.5)	44.0 (20.0)			
	14 (356)	231																	
44 (1100)	12 (305)	231	2.4 (61)	1.2 (30)	1.1 (28)	3.1	2.0				1774.44 (11448)	80 (5.5)	26 (660)	198.0 (89.8)	104.0 (37.2)	44.0 (20.0)			
	14 (356)	231																	
46 (1150)	12 (305)	231	2.4 (61)	1.2 (30)	1.1 (28)	3.0	2.0				1926.81 (12431)	80 (5.5)	26 (660)	205.0 (93.0)	127.0 (57.6)	44.0 (20.0)			
	14 (356)	231																	
48 (1200)	12 (305)	231	2.4 (61)	1.2 (30)	1.1 (28)	2.9	2.0				2085.53 (13455)	80 (5.5)	26 (660)	211.0 (95.7)	132.0 (59.9)	44.0 (20.0)			
	14 (356)	231																	
50 (1250)	12 (305)	231	2.4 (61)	1.2 (30)	1.1 (28)	2.8	2.0				2250.45 (14519)	80 (5.5)	26 (660)	240.0 (108.8)	134.0 (60.0)	44.0 (20.0)			
	14 (356)	231																	
52 (1300)	12 (305)	231	2.4 (61)	1.2 (30)	1.1 (28)	2.6	2.0				2421.72 (15624)	80 (5.5)	26 (660)	256.0 (116.1)	136.0 (61.7)	60.0 (27.0)			
	14 (356)	231																	
54 (1350)	12 (305)	231	2.4 (61)	1.2 (30)	1.1 (28)	2.6	2.0				2599.35 (16770)	80 (5.5)	26 (660)	265.0 (120.1)	150.0 (68.0)	63.0 (28.6)			
	14 (356)	231																	
56 (1400)	12 (305)	231	2.4 (61)	1.2 (30)	1.1 (28)	2.5	2.0				2931.67 (18914)	80 (5.5)	26 (660)	288.0 (130.6)	165.0 (70.8)	63.0 (28.6)			
	14 (356)	231																	
58 (1450)	12 (305)	231	2.4 (61)	1.2 (30)	1.1 (28)	2.4	2.0				3011.34 (19428)	80 (5.5)	26 (660)	300.0 (136.1)	190.0 (86.2)	66.2 (30.0)			
	14 (356)	231																	
60 (1500)	12 (305)	231	2.4 (61)	1.2 (30)	1.1 (28)	2.3	2.0				3208.97 (20703)	80 (5.5)	26 (660)	310.0 (140.6)	200.0 (90.7)	68.3 (31.2)			
	14 (356)	231																	
66 (1650)	12 (305)	231	2.4 (61)	1.2 (30)	1.1 (28)	2.1	2.0				3839.51 (24771)	80 (5.5)	26 (660)	350.0 (158.7)	240.0 (108.8)	71.0 (32.2)			
	14 (356)	231																	
68 (1700)	12 (305)	231	2.4 (61)	1.2 (30)	1.1 (28)	2.0	2.0				4062.24 (28208)	70 (5.0)	26 (660)	368.8 (166.9)	227.0 (103.0)	76.3 (34.6)			
	14 (356)	231																	

**U  
N  
D  
E  
R  
C  
U  
R  
R  
E  
N  
T  
T  
E  
S  
T  
I  
N  
G**

Table 2: Sizes • Movements • Forces • Weights													See Notes Below					
EXPANSION JOINT SIZE Nom. I.D. x Inch / (mm)	NEUTRAL LENGTH Inch / (mm)	EXPANSION JOINT STYLE	231 / 221 Movement Capability: From Neutral Position						Spring Rate Capability Based on 1" of Movement at Zero Pressure Conditions					Operating <sup>4</sup> Conditions		Weights <sup>5</sup> lbs / (kgs)		
			Axial Compression Inch / (mm)	Axial Extension Inch / (mm)	Lateral Deflection Inch / (mm)	Angular <sup>1</sup> Deflection Degrees	Torsional <sup>2</sup> Rotation Degrees	Force lbs per 1" rated Compression	Force lbs per 1" rated Extension	Force lbs per 1" rated Lateral Deflection	Force ft-lbs per 1" rated Angular	Thrust Factor <sup>3</sup> InZ / (cm2)	Positive PSIG / (Bar)	Vacuum Inches of Hg/ (mm of Hg)	Expansion Joint Assembly	Retaining Ring Set	Control <sup>6</sup> Rod Assembly	
72 (1800)	<u>12</u> (305)	231	2.4 (61)	1.2 (30)	1.1 (28)	1.9	2.0	<b>U N D E R C U R R E N T T E S T I N G</b>	4526.62 (29244)	70 (5.0)	26 (660)	390.0 (176.9)	290.0 (131.5)	87.0 (39.4)				
	14 (356)	231	2.3 (57)	1.2 (30)	1.0 (25)	1.8	2.0		5410.60 (34907)	85 (6.0)	26 (660)	410.0 (186.0)	315.0 (142.9)	103.0 (46.7)				
78 (1950)	<u>12</u> (305)	231	2.3 (57)	1.2 (30)	1.0 (25)	1.6	2.0		6221.13 (40136)	85 (6.0)	26 (660)	440.0 (200.0)	350.0 (158.0)	113.0 (51.3)				
	14 (356)	231	2.3 (57)	1.2 (30)	1.0 (25)	1.6	2.0		7088.11 (45730)	85 (6.0)	26 (660)	448.0 (203.1)	363.0 (164.6)	125.0 (56.7)				
84 (2100)	<u>12</u> (305)	231	2.3 (57)	1.2 (30)	1.0 (25)	1.4	2.0		8011.85 (51689)	85 (6.0)	26 (660)	466.0 (211.3)	367.0 (170.5)	125.0 (56.7)				
	14 (356)	231	2.3 (57)	1.2 (30)	1.0 (25)	1.3	2.0		8992.02 (58013)	85 (6.0)	26 (660)	485.8 (220.0)	395.0 (179.1)	137.0 (62.1)				
90 (2250)	<u>12</u> (305)	231	2.3 (57)	1.2 (30)	1.1 (28)	1.2	2.0		10028.75 (64702)	85 (6.0)	26 (660)	510.0 (231.3)	425.0 (192.7)	139.0 (63.0)				
	14 (356)	231	2.3 (57)	1.2 (30)	1.0 (25)	1.1	2.0		12271.84 (79173)	85 (6.0)	26 (660)	540.0 (244.9)	565.0 (256.2)	151.0 (65.8)				

Neutral lengths underlined are the recommended minimum lengths.

Metric Conversion Formula: Nominal I.D.: in. x 25 = mm; Dimensions: in. x 25.4 = mm; Pressure: PSIG x .069 = Bar

NOTES:

- The degree of angular movement is based on the maximum rated extension.
- Torsional movement is expressed when the expansion joint is at its neutral length.
- To determine "end thrust", multiply thrust factor by operating pressure of system.
- Pressure rating is based on 170°F operating temperature with a 4:1 safety factor. At higher temperatures, the pressure rating is reduced slightly. Hydrostatic testing at 1.5 times rated or working pressure for 10 minutes is available upon request.
- Weights are approximate and vary due to OAL.
- Control rod unit weight consists of one rod with washers, nuts and two control rod plates. Multiply number of control rods needed for application (as specified in the Fluid Sealing Association's Technical Handbook) to determine correct weights.

Toll Free Phone . . . . . (800) 344-3246  
 International Calls . . . . . (209) 943-6088  
 Facsimile . . . . . (209) 943-0242  
 E-mail . . . . . sales@procoproducts.com  
 Web Site . . . . . http://www.procoproducts.com

### Filled Arch Rubber Expansion Joints

Known as Style FA231 or Style FA221 the Series FA230 Rubber Expansion Joints are designed to eliminate flow turbulence and collection of solids in the arch core. Filled Arch Rubber Expansion Joints can be found in applications such as sludge, slurries or other heavy solids where material entrapment, high flow velocity or high abrasion conditions exist. Filled arch products are manufactured with seamless tube and are built as an integral part of the carcass. Although the tube is made of a low durometer filler stock, movement ratings of the Style FA231 or Style FA221 are 50% less than those movements listed in the table above. PROCO can manufacture any size listed in the table above.

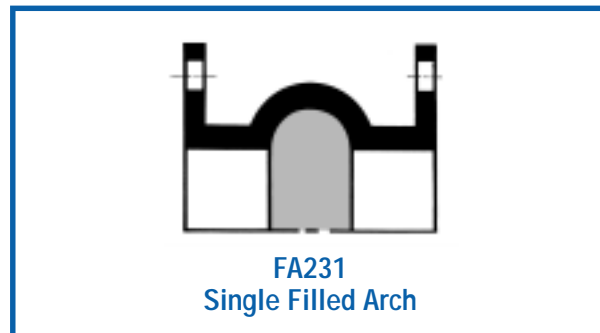

# PROCO

STYLE

# 232/222

double wide arch spool type  
rubber expansion joints



Table 3: Sizes • Movements • Forces • Weights

See Notes Page 9

EXPANSION JOINT SIZE Norm. I.D. x Inch / (mm)	NEUTRAL LENGTH Inch / (mm)		EXPANSION JOINT STYLE	232 / 222 Movement Capability: From Neutral Position					Spring Rate Capability Based on 1" of Movement at Zero Pressure Conditions					Operating <sup>4</sup> Conditions		Weights <sup>5</sup> lbs / (kgs)		
				Axial Compression Inch / (mm)	Axial Extension Inch / (mm)	Lateral Deflection Inch / (mm)	Angular <sup>1</sup> Deflection Degrees	Torsional <sup>2</sup> Rotation Degrees	Force lbs per 1" rated Compression	Force lbs per 1" rated Extension	Force lbs per 1" rated Lateral Deflection	Force ft-lbs per 1° rated Angular	Thrust Factor <sup>3</sup> Inz / (cm2)	Positive PSIG / (Bar)	Vacuum Inches of Hg/ (mm of Hg)	Expansion Joint Assembly	Retaining Ring Set	Control <sup>6</sup> Rod Assembly
1.5 (40)	10 (254)	232	2.4 (61)	1.2 (30)	1.2 (30)	58.0	2.0	<b>U N D E R C U R R E N T T E S T I N G</b>	7.44 (48)	200 (14.0)	26 (660)	3.0 (1.4)	2.5 (1.1)	2.3 (1.0)				
			2.8 (70)	1.4 (34)	1.2 (30)	53.8	2.0		12.40 (80)	200 (14.0)	26 (660)	4.0 (1.8)	4.0 (1.8)	2.8 (1.3)				
2.5 (65)	10 (254)	232	2.8 (70)	1.4 (34)	1.2 (30)	47.4	2.0		15.66 (101)	200 (14.0)	26 (660)	4.5 (2.0)	4.5 (2.0)	2.8 (1.3)				
			2.8 (70)	1.4 (34)	1.2 (30)	42.2	2.0		19.36 (125)	200 (14.0)	26 (660)	6.0 (2.7)	5.5 (2.5)	2.8 (1.3)				
3 (80)	10 (254)	232	2.8 (70)	1.4 (34)	1.2 (30)	34.2	2.0		27.90 (180)	200 (14.0)	26 (660)	8.5 (3.9)	8.0 (3.5)	2.8 (1.3)				
			2.8 (70)	1.4 (34)	1.2 (30)	28.6	2.0		38.13 (246)	190 (13.0)	26 (660)	9.5 (4.3)	8.5 (3.9)	4.0 (1.8)				
4 (100)	10 (254)	232	2.8 (70)	1.4 (34)	1.2 (30)	24.4	2.0		49.91 (322)	190 (13.0)	26 (660)	11.5 (5.2)	9.5 (4.3)	4.0 (1.8)				
			2.8 (70)	1.4 (34)	1.2 (30)	24.4	2.0		49.91 (322)	190 (13.0)	26 (660)	11.5 (5.2)	9.5 (4.3)	4.0 (1.8)				
5 (125)	10 (254)	232	2.8 (70)	1.4 (34)	1.2 (30)	18.8	2.0		77.97 (503)	190 (13.0)	26 (660)	16.0 (7.3)	14.5 (6.6)	8.0 (3.6)				
			2.8 (70)	1.4 (34)	1.2 (30)	18.8	2.0		77.97 (503)	190 (13.0)	26 (660)	16.0 (7.3)	14.5 (6.6)	8.0 (3.6)				
6 (150)	10 (254)	232	1.4 (35)	0.8 (20)	1.0 (25)	8.2	2.0		116.97 (755)	190 (13.0)	26 (660)	28.3 (12.8)	17.0 (7.7)	10.0 (4.5)				
			3.2 (80)	1.6 (40)	1.6 (40)	17.8	2.0		119.97 (774)	190 (13.0)	26 (660)	29.0 (13.2)	17.0 (7.7)	10.0 (4.5)				
8 (200)	10 (254)	232	1.4 (35)	0.8 (20)	1.0 (25)	6.8	2.0		157.74 (1018)	190 (13.0)	26 (660)	36.0 (16.3)	24.5 (11.0)	10.0 (4.5)				
			3.2 (80)	1.6 (40)	1.6 (40)	14.9	2.0		161.98 (1045)	190 (13.0)	26 (660)	36.0 (16.3)	24.5 (11.0)	10.0 (4.5)				
10 (250)	12 (305)	222	1.4 (35)	0.8 (20)	1.0 (25)	5.8	2.0		204.61 (1320)	140 (9.5)	26 (660)	44.0 (20.0)	27.0 (12.3)	12.0 (5.4)				
			3.2 (80)	1.6 (40)	1.6 (40)	12.9	2.0		210.18 (1356)	130 (9.0)	26 (660)	44.0 (20.0)	27.0 (12.3)	12.0 (5.4)				
12 (300)	12 (305)	232	3.2 (80)	1.6 (40)	1.6 (40)	12.9	2.0		210.18 (1356)	130 (9.0)	26 (660)	44.0 (20.0)	27.0 (12.3)	12.0 (5.4)				
			1.4 (35)	0.8 (20)	1.0 (25)	6.8	2.0		257.54 (1662)	110 (7.5)	26 (660)	53.0 (24.0)	33.5 (15.2)	15.0 (6.8)				
14 (350)	14 (356)	232	3.2 (80)	1.6 (40)	1.6 (40)	11.3	2.0		264.74 (1708)	115 (8.0)	26 (660)	53.0 (24.0)	33.5 (15.2)	15.0 (6.8)				
			3.2 (80)	1.6 (40)	1.6 (40)	11.3	2.0		264.74 (1708)	115 (8.0)	26 (660)	53.0 (24.0)	33.5 (15.2)	15.0 (6.8)				
16 (400)	12 (305)	222	1.6 (40)	1.0 (25)	1.0 (25)	7.0	2.0	316.59 (2043)	110 (7.5)	26 (660)	61.0 (27.7)	34.0 (15.5)	16.0 (7.2)					
			3.2 (80)	1.6 (40)	1.6 (40)	12.9	2.0	325.50 (2100)	115 (8.0)	26 (660)	61.0 (27.7)	34.0 (15.5)	16.0 (7.2)					
18 (450)	14 (356)	232	3.2 (80)	1.6 (40)	1.6 (40)	10.1	2.0	325.50 (2100)	115 (8.0)	26 (660)	61.0 (27.7)	34.0 (15.5)	16.0 (7.2)					
			3.2 (80)	1.6 (40)	1.6 (40)	10.1	2.0	325.50 (2100)	115 (8.0)	26 (660)	61.0 (27.7)	34.0 (15.5)	16.0 (7.2)					
20 (500)	12 (305)	222	1.6 (40)	1.0 (25)	1.0 (25)	5.6	2.0	381.69 (2463)	110 (7.5)	26 (660)	73.0 (33.1)	38.0 (17.3)	16.0 (7.2)					
			3.2 (80)	1.6 (40)	1.6 (40)	9.1	2.0	392.62 (2533)	115 (8.0)	26 (660)	73.0 (33.1)	38.0 (17.3)	16.0 (7.2)					
20 (500)	16 (406)	232	3.2 (80)	1.6 (40)	1.6 (40)	9.1	2.0	392.62 (2533)	115 (8.0)	26 (660)	73.0 (33.1)	38.0 (17.3)	16.0 (7.2)					
			3.2 (80)	1.6 (40)	1.6 (40)	9.1	2.0	392.62 (2533)	115 (8.0)	26 (660)	73.0 (33.1)	38.0 (17.3)	16.0 (7.2)					



Table 3: Sizes • Movements • Forces • Weights														See Notes Below				
EXPANSION JOINT SIZE Nom. I.D. x Inch / (mm)	NEUTRAL LENGTH Inch / (mm)	EXPANSION JOINT STYLE	232 / 222 Movement Capability: From Neutral Position						Spring Rate Capability Based on 1" of Movement at Zero Pressure Conditions					Operating <sup>4</sup> Conditions		Weights <sup>5</sup> lbs / (kgs)		
			Axial Compression Inch / (mm)	Axial Extension Inch / (mm)	Lateral Deflection Inch / (mm)	Angular <sup>1</sup> Deflection Degrees	Torsional <sup>2</sup> Rotation Degrees	Force lbs per 1" rated Compression	Force lbs per 1" rated Extension	Force lbs per 1" rated Lateral Deflection	Force ft-lbs per 1" rated Angular	Thrust Factor <sup>3</sup> In/Z / (cm/z)	Positive PSIG/ (Bar)	Vacuum Inches of Hg/ (mm of Hg)	Expansion Joint Assembly	Retaining Ring Set	Control <sup>6</sup> Rod Assembly	
24 (600)	<u>14</u> (356)	222	1.6 (40)	1.0 (25)	1.0 (25)	4.7	2.0	<b>U N D E R C U R R E N T T E S T I N G</b>	562.82 (3631)	100 (7.0)	26 (660)	88.0 (40.0)	48.0 (21.8)	20.0 (9.1)				
	<u>16</u> (406)	232	4.0 (102)	2.0 (51)	2.0 (51)	9.5	2.0		562.03 (3626)	100 (7.0)	26 (660)	88.0 (40.0)	48.0 (21.8)	20.0 (9.1)				
30 (750)	<u>14</u> (356)	222	1.9 (48)	1.0 (25)	1.0 (25)	4.3	2.0		798.58 (5152)	90 (6.0)	26 (660)	127.0 (57.6)	63.0 (28.6)	29.5 (13.3)				
	<u>16</u> (406)	232	4.0 (102)	2.0 (51)	2.0 (51)	7.6	2.0		842.27 (5434)	90 (6.0)	26 (660)	127.0 (57.6)	63.0 (28.6)	29.5 (13.3)				
34 (850)	<u>14</u> (356)	222	1.9 (48)	1.0 (25)	1.0 (25)	3.8	2.0		1007.86 (8502)	90 (6.0)	26 (660)	134.0 (60.8)	72.0 (32.7)	43.0 (19.5)				
	<u>16</u> (406)	232	4.0 (102)	2.0 (51)	2.0 (51)	6.7	2.0		1060.51 (6842)	90 (6.0)	26 (660)	134.8 (60.8)	72.0 (32.7)	43.0 (19.5)				
36 (900)	<u>14</u> (356)	222	1.9 (48)	1.0 (25)	1.0 (25)	3.6	2.0		1217.14 (7852)	90 (6.0)	26 (660)	156.0 (70.8)	76.0 (34.5)	43.0 (19.5)				
	<u>16</u> (406)	232	4.0 (102)	2.0 (51)	2.0 (51)	6.3	2.0		1179.09 (7607)	90 (6.0)	26 (660)	156.0 (70.8)	76.0 (34.5)	43.0 (19.5)				
42 (1050)	<u>14</u> (356)	222	2.2 (56)	1.5 (38)	1.2 (30)	3.1	2.0		1673.13 (10775)	80 (5.5)	26 (660)	211.0 (95.7)	100.0 (45.4)	44.0 (20.0)				
	<u>16</u> (406)	232	4.8 (120)	2.4 (61)	2.2 (56)	6.5	2.0		1628.28 (10505)	80 (5.5)	26 (660)	211.0 (95.7)	100.0 (45.4)	44.0 (20.0)				
48 (1200)	<u>14</u> (356)	222	2.2 (56)	1.5 (38)	1.2 (30)	2.7	2.0		2134.86 (13773)	80 (5.5)	26 (660)	222.0 (100.7)	132.0 (59.9)	44.0 (20.0)				
	<u>16</u> (406)	232	4.8 (120)	2.4 (61)	2.2 (56)	5.7	2.0		2085.53 (13455)	80 (5.5)	26 (660)	222.8 (101.0)	132.0 (59.9)	44.0 (20.0)				

**Larger diameters available upon request.**

Neutral lengths underlined are the recommended minimum lengths.

Metric Conversion Formula: Nominal I.D.: in. x 25 = mm; Dimensions: in. x 25.4 = mm; Pressure: PSIG x .069 = Bar

NOTES:

- The degree of angular movement is based on the maximum rated extension.
- Torsional movement is expressed when the expansion joint is at neutral length.
- To determine "end thrust", multiply thrust factor by operating pressure of system.
- Pressure rating is based on 170°F operating temperature with a 4:1 safety factor. At higher temperatures, the pressure rating is reduced slightly. Hydrostatic testing at 1.5 times rated or working pressure for 10 minutes is available upon request.
- Weights are approximate and vary due to OAL.
- Control rod unit weight consists of one rod with washers, nuts and two control rod plates. Multiply number of control rods needed for application (as specified in the Fluid Sealing Association's Technical Handbook) to determine correct weights.

Toll Free Phone . . . . . (800) 344-3246  
 International Calls . . . . . (209) 943-6088  
 Facsimile . . . . . (209) 943-0242  
 E-mail . . . . . sales@procoproducts.com  
 Web Site . . . . . http://www.procoproducts.com

### Filled Arch Rubber Expansion Joints

Known as Style FA232 or Style FA222 the Series FA230 Rubber Expansion Joints are designed to eliminate flow turbulence and collection of solids in the arch core. Filled Arch Rubber Expansion Joints can be found in applications such as sludge, slurries or other heavy solids where material entrapment, high flow velocity or high abrasion conditions exist. Filled arch products are manufactured with seamless tube and are built as an integral part of the carcass. Although the tube is made of a low durometer filler stock, movement ratings of the Style FA232 or Style FA222 are 50% less than those movements listed in the table above. PROCO can manufacture any size listed in the table above.

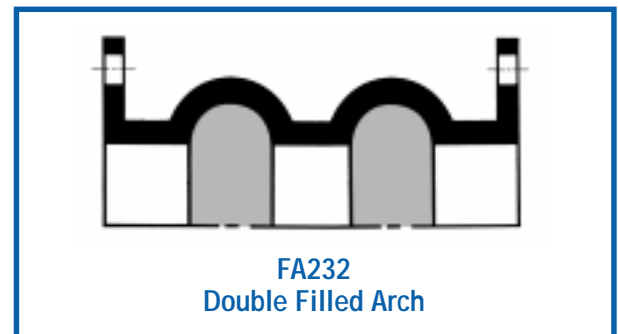

# PROCO

STYLE

# 233/223

triple wide arch spool type  
rubber expansion joints



Table 4: Sizes • Movements • Forces • Weights

See Notes Page 11

EXPANSION JOINT SIZE Nom. I.D. X Inch / (mm)	NEUTRAL LENGTH Inch / (mm)	EXPANSION JOINT STYLE	233 / 223 Movement Capability: From Neutral Position					Spring Rate Capability Based on 1" of Movement at Zero Pressure Conditions					Operating <sup>4</sup> Conditions		Weights <sup>5</sup> lbs / (kgs)		
			Axial Compression Inch / (mm)	Axial Extension Inch / (mm)	Lateral Deflection Inch / (mm)	Angular <sup>1</sup> Deflection Degrees	Torsional <sup>2</sup> Rotation Degrees	Force lbs per 1" rated Compression	Force lbs per 1" rated Extension	Force lbs per 1" rated Lateral Deflection	Force lb-inches per 1" rated Angular	Thrust Factor <sup>3</sup> In <sup>2</sup> / (cm <sup>2</sup> )	Positive PSIG/ (Bar)	Vacuum Inches of Hg/ (mm of Hg)	Expansion Joint Assembly	Retaining Ring Set	Control <sup>6</sup> Rod Assembly
1.5 (40)	12 (305)	223	1.3 (33)	0.7 (18)	1.5 (38)	41.5	2.0	U N D E R  C U R R E N T  T E S T I N G	6.20 (40)	200 (14.0)	26 (660)	4.0 (1.8)	2.5 (1.1)	6.0 (2.7)			
	14 (356)	233	3.5 (90)	1.8 (45)	1.9 (48)	67.4	2.0		7.44 (48)	200 (14.0)	26 (660)	4.0 (1.8)	2.5 (1.1)	6.0 (2.7)			
2 (50)	12 (305)	223	1.3 (33)	0.7 (18)	1.5 (38)	33.5	2.0		7.79 (50)	200 (14.0)	26 (660)	5.5 (2.5)	4.0 (1.8)	7.0 (3.2)			
	14 (356)	233	4.1 (105)	2.0 (51)	1.9 (48)	63.9	2.0		12.40 (80)	200 (14.0)	26 (660)	5.5 (2.5)	4.0 (1.8)	7.0 (3.2)			
2.5 (65)	12 (305)	223	1.3 (33)	0.7 (18)	1.5 (38)	27.9	2.0		14.73 (95)	200 (14.0)	26 (660)	6.0 (2.7)	4.5 (2.0)	7.0 (3.2)			
	14 (356)	233	4.1 (105)	2.0 (51)	1.9 (48)	58.5	2.0		15.66 (101)	200 (14.0)	26 (660)	6.0 (2.7)	4.5 (2.0)	7.0 (3.2)			
3 (80)	12 (305)	223	1.3 (33)	0.7 (18)	1.5 (38)	23.8	2.0		17.52 (113)	200 (14.0)	26 (660)	7.0 (3.2)	5.5 (4.3)	7.3 (3.4)			
	14 (356)	233	4.1 (105)	2.0 (51)	1.9 (48)	53.4	2.0		19.38 (125)	200 (14.0)	26 (660)	7.0 (3.2)	5.5 (4.3)	7.3 (3.4)			
4 (100)	12 (305)	223	1.3 (33)	0.7 (18)	1.5 (38)	22.5	2.0		26.66 (172)	200 (14.0)	26 (660)	9.0 (4.1)	8.0 (3.6)	8.0 (3.6)			
	14 (356)	233	4.1 (105)	2.0 (51)	1.9 (48)	45.6	2.0		27.90 (180)	200 (14.0)	26 (660)	9.0 (4.1)	8.0 (3.6)	8.0 (3.6)			
5 (125)	12 (305)	223	1.7 (43)	0.8 (20)	1.5 (38)	18.3	2.0		36.43 (235)	190 (13.0)	26 (660)	11.0 (5.0)	8.5 (3.9)	8.0 (3.6)			
	14 (356)	233	4.1 (105)	2.0 (51)	1.9 (48)	39.2	2.0		38.13 (246)	190 (13.0)	26 (660)	11.0 (5.0)	8.5 (3.9)	8.0 (3.6)			
6 (150)	12 (305)	223	1.7 (43)	0.8 (20)	1.5 (38)	15.4	2.0		47.71 (308)	190 (13.0)	26 (660)	13.5 (6.1)	9.5 (4.3)	10.0 (4.5)			
	14 (356)	233	4.1 (105)	2.0 (51)	1.9 (48)	34.2	2.0		49.91 (322)	190 (13.0)	26 (660)	13.5 (6.1)	9.5 (4.3)	10.0 (4.5)			
	16 (406)	233	4.1 (105)	2.0 (51)	1.9 (48)	34.2	2.0		49.91 (322)	190 (13.0)	26 (660)	13.5 (6.1)	9.5 (4.3)	12.0 (5.4)			
8 (200)	12 (305)	223	2.2 (56)	1.1 (28)	1.5 (38)	15.0	2.0		82.28 (530)	190 (13.0)	26 (660)	18.0 (8.2)	14.5 (6.6)	12.0 (5.4)			
	14 (356)	233	4.1 (105)	2.0 (51)	1.9 (48)	27.0	2.0		77.97 (503)	190 (13.0)	26 (660)	18.0 (8.2)	14.5 (6.6)	12.0 (5.4)			
	16 (406)	233	4.1 (105)	2.0 (51)	1.9 (48)	27.0	2.0		77.97 (503)	190 (13.0)	26 (660)	18.0 (8.2)	14.5 (6.6)	12.0 (5.4)			
10 (250)	14 (356)	223	2.2 (56)	1.1 (28)	1.5 (38)	12.1	2.0		116.97 (755)	190 (13.0)	26 (660)	31.0 (14.1)	17.0 (7.7)	15.0 (6.8)			
	16 (406)	223	2.2 (56)	1.1 (28)	1.1 (28)	12.1	2.0		116.97 (755)	190 (13.0)	26 (660)	31.0 (14.1)	17.0 (7.7)	15.0 (6.8)			
	18 (457)	233	4.7 (120)	2.4 (61)	2.4 (61)	25.6	2.0	119.97 (774)	190 (13.0)	26 (660)	31.0 (14.1)	17.0 (7.7)	16.0 (7.2)				
12 (300)	14 (356)	223	2.2 (56)	1.1 (28)	1.5 (38)	10.1	2.0	157.74 (1018)	190 (13.0)	26 (660)	40.0 (18.1)	24.5 (11.0)	16.0 (7.2)				
	16 (406)	223	2.2 (56)	1.1 (28)	1.1 (28)	10.1	2.0	157.74 (1018)	190 (13.0)	26 (660)	40.0 (18.1)	24.5 (11.0)	16.0 (7.2)				
	18 (457)	233	4.7 (120)	2.4 (61)	2.4 (61)	5.6	2.0	161.98 (1045)	190 (13.0)	26 (660)	40.0 (18.1)	24.5 (11.0)	16.0 (7.2)				
14 (350)	16 (406)	223	2.2 (56)	1.1 (28)	1.5 (38)	9.1	2.0	204.61 (1320)	130 (9.0)	26 (660)	48.5 (22.0)	27.0 (12.3)	16.0 (7.2)				
	18 (457)	233	4.7 (120)	2.4 (61)	2.4 (61)	9.1	2.0	210.18 (1356)	130 (9.0)	26 (660)	48.5 (22.0)	27.0 (12.3)	16.0 (7.2)				

See Notes Page 11

Table 4: Sizes • Movements • Forces • Weights																	See Notes Below	
EXPANSION JOINT SIZE Nom. I.D. x Inch / (mm)	NEUTRAL LENGTH Inch / (mm)		EXPANSION JOINT STYLE	233 / 223 Movement Capability: From Neutral Position					Spring Rate Capability Based on 1" of Movement at Zero Pressure Conditions					Operating <sup>4</sup> Conditions		Weights <sup>5</sup> lbs / (kgs)		
				Axial Compression Inch / (mm)	Axial Extension Inch / (mm)	Lateral Deflection Inch / (mm)	Angular <sup>1</sup> Deflection Degrees	Torsional <sup>2</sup> Rotation Degrees	Force lbs per 1" rated Compression	Force lbs per 1" rated Extension	Force lbs per 1" rated Lateral Deflection	Force lb-lbs per 1" rated Angular	Thrust Factor <sup>3</sup> Inz / (cmz)	Positive PSIG/ (Bar)	Vacuum Inches of Hg/ (mm of Hg)	Expansion Joint Assembly	Retaining Ring Set	Control <sup>6</sup> Rod Assembly
14 (350)	20 (508)		233	4.7 (120)	2.4 (61)	2.4 (61)	18.9	2.0	U N D E R C U R R E N T T E S T I N G	210.18 (1356)	130 (9.0)	26 (660)	48.5 (22.0)	27.0 (12.3)	20.0 (9.1)			
	16 (400)		223	4.0 (102)	2.0 (51)	2.0 (51)	10.5	2.0		257.54 (1662)	115 (8.0)	26 (660)	55.0 (24.9)	33.5 (15.2)	20.0 (9.1)			
16 (400)	18 (457)		233	4.7 (120)	2.4 (61)	2.4 (61)	16.7	2.0		264.74 (1708)	115 (8.0)	26 (660)	55.0 (24.9)	33.5 (15.2)	20.0 (9.1)			
	20 (508)		233	4.7 (120)	2.4 (61)	2.4 (61)	16.7	2.0		264.74 (1708)	115 (8.0)	26 (660)	55.0 (24.9)	33.5 (15.2)	20.0 (9.1)			
18 (450)	16 (406)		223	4.0 (102)	2.0 (51)	2.0 (51)	9.3	2.0		316.59 (2043)	115 (8.0)	26 (660)	66.0 (29.9)	34.0 (15.5)	21.0 (9.5)			
	18 (457)		233	4.7 (120)	2.4 (61)	2.4 (61)	14.9	2.0		325.50 (2100)	115 (8.0)	26 (660)	66.0 (29.9)	34.0 (15.5)	21.0 (9.5)			
18 (450)	20 (508)		233	4.7 (120)	2.4 (61)	2.4 (61)	14.9	2.0		325.50 (2100)	115 (8.0)	26 (660)	66.0 (29.9)	34.0 (15.5)	21.0 (9.5)			
	18 (457)		233	4.7 (120)	2.4 (61)	2.4 (61)	13.5	2.0		392.62 (2533)	115 (8.0)	26 (660)	78.0 (35.4)	38.0 (17.3)	21.0 (9.5)			
20 (500)	20 (508)		233	4.7 (120)	2.4 (61)	2.4 (61)	13.5	2.0		392.62 (2533)	115 (8.0)	26 (660)	78.0 (35.4)	38.0 (17.3)	21.0 (9.5)			
	18 (457)		223	4.8 (120)	2.4 (61)	2.2 (55)	14.0	2.0		562.82 (3631)	100 (7.0)	26 (660)	91.5 (41.5)	48.0 (21.8)	32.0 (14.5)			
24 (600)	20 (508)		233	6.0 (150)	3.0 (75)	2.7 (69)	14.0	2.0		562.03 (3626)	100 (7.0)	26 (660)	91.5 (41.5)	48.0 (21.8)	32.0 (14.5)			
	18 (457)		223	4.8 (120)	2.4 (61)	2.2 (55)	11.3	2.0		798.58 (5152)	90 (6.0)	26 (660)	131.0 (59.4)	63.0 (28.6)	32.0 (14.5)			
30 (750)	20 (508)		233	6.0 (150)	3.0 (75)	2.7 (69)	11.3	2.0		842.27 (5434)	90 (6.0)	26 (660)	131.0 (59.4)	63.0 (28.6)	32.0 (14.5)			
	18 (457)		223	4.8 (120)	2.4 (61)	2.2 (55)	9.5	2.0		1217.14 (7873)	90 (6.0)	26 (660)	157.0 (71.2)	76.0 (34.5)	43.0 (19.5)			
36 (900)	20 (508)		233	6.0 (150)	3.0 (75)	2.7 (69)	9.5	2.0		1179.09 (7607)	90 (6.0)	26 (660)	157.0 (71.2)	76.0 (34.5)	43.0 (19.5)			

**Larger diameters available upon request.**

Neutral lengths underlined are the recommended minimum lengths.

Metric Conversion Formula: Nominal I.D.: in. x 25.4 = mm; Dimensions: in. x 25.4 = mm; Pressure: PSIG x .069 = Bar

NOTES:

- The degree of angular movement is based on the maximum rated extension.
- Torsional movement is expressed when the expansion joint is at neutral length.
- To determine "end thrust", multiply thrust factor by operating pressure of system.
- Pressure rating is based on 170°F operating temperature with a 4:1 safety factor. At higher temperatures, the pressure rating is reduced slightly. Hydrostatic testing at 1.5 times rated or working pressure for 10 minutes is available upon request.
- Weights are approximate and vary due to OAL.
- Control rod unit weight consists of one rod with washers, nuts and two control rod plates. Multiply number of control rods needed for application (as specified in the Fluid Sealing Association's Technical Handbook) to determine correct weights.

**Filled Arch Rubber Expansion Joints**

Known as Style FA233 or Style FA223, the Series FA230 Rubber Expansion Joints are designed to eliminate flow turbulence and collection of solids in the arch core. Filled Arch Rubber Expansion Joints can be found in applications such as sludge, slurries or other heavy solids where material entrapment, high flow velocity or high abrasion conditions exist. Filled arch products are manufactured with seamless tube and are built as an integral part of the carcass. Although the tube is made of a low durometer filler stock, movement ratings of the Style FA233 or Style FA223 are 50% less than those movements listed in the table above. PROCO can manufacture any size listed in the table above.

Toll Free Phone . . . . . (800) 344-3246  
 International Calls . . . . . (209) 943-6088  
 Facsimile . . . . . (209) 943-0242  
 E-mail . . . . . sales@procoproducts.com  
 Web Site . . . . . http://www.procoproducts.com

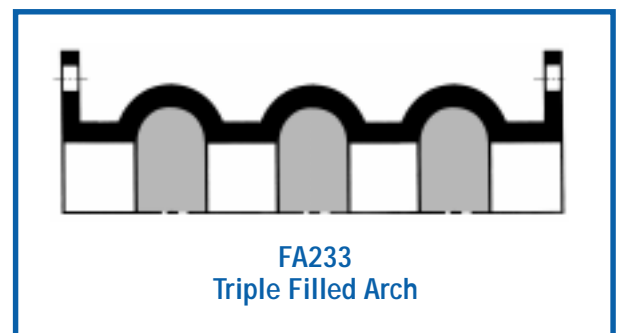

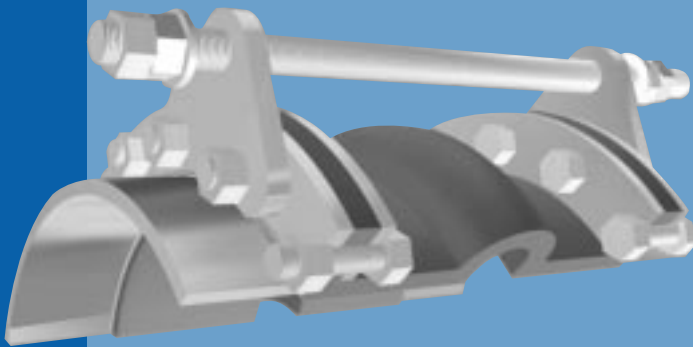
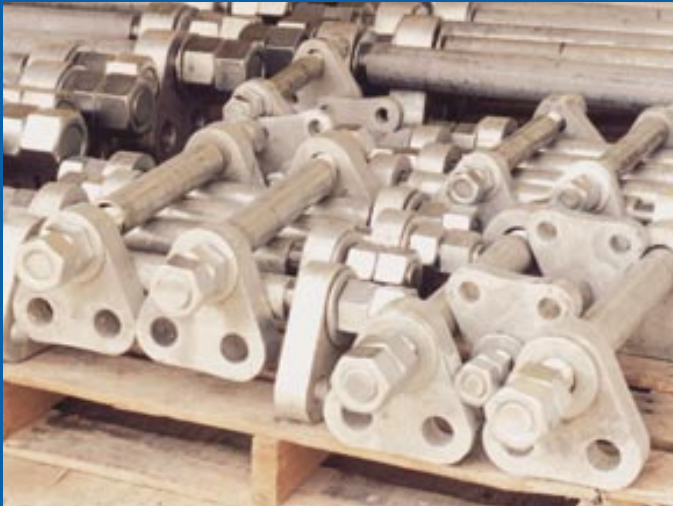

Figure 1: Limit Rod

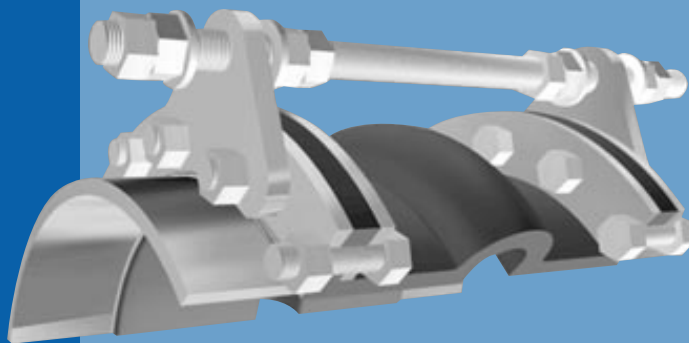

Figure 2: Control Rod

**Definition** — A control unit assembly is a system of two or more control rod units (limit rods, tie rods or compression sleeves) placed across an expansion joint from flange to flange to minimize possible damage caused by excessive motion of a pipeline. The failure of an anchor or some other piece of equipment in a pipeline can cause excessive motion. The control unit assemblies can be set at the maximum allowable expansion and/or contraction of the rubber expansion joint. When used in this manner, control units are an additional safety factor and can minimize possible damage to adjacent equipment.

#### Use of Control Units with Rubber Expansion Joints

Rubber expansion joints must be installed between two fixed anchor points in a piping system. The pipe system must be rigidly anchored on both sides of the expansion joint to control expansion or contraction of the line. Piping anchors must be capable of withstanding the line thrusts generated by internal pressure or wide temperature fluctuations. When proper anchoring cannot be provided, **CONTROL UNITS ARE REQUIRED.**

Listed below are three (3) control unit configurations supplied by PROCO and are commonly used with rubber expansion joints in piping systems.

**Figure 1** — Known as a “LIMIT ROD”, this control unit configuration will allow an expansion joint to extend to a predetermined extension setting. Nuts shall be field set to no more than the maximum allowable extension movement of a rubber expansion joint. Refer to Tables 2, 3, or 4 in this manual. **Consult the systems engineer for proper nut settings prior to system operation.**

**Figure 2** — Known as a “CONTROL ROD”, this control unit configuration is used to allow specified pipe expansion (expansion joint axial compression) and pipe contraction (expansion joint axial extension) movements. Nuts shall be field set to no more than the maximum allowable extension or compression of a rubber expansion joint. Refer to Tables 2, 3 or 4 in this Manual.

Internal and external nuts can also be field set to allow for no movement in the horizontal plane. This setting will allow the rubber to move laterally while keeping expansion joint thrust forces low on adjacent equipment. Spherical washers can also be furnished (upon request) to combat any potential “nut to plate” binding during offset. **Consult the systems engineer for proper nut settings prior to system operation.**

**Figure 3** — Known as a “COMPRESSION SLEEVE”, this configuration is used to allow for specified pipe expansion (expansion joint axial compression) and pipe contraction (expansion joint extension) movements. Nuts shall be field set to no more than the maximum allowable extension of a rubber expansion joint. Refer to Tables 2, 3, or 4 in this manual. PROCO will manufacture each compression sleeve to allow for no axial movement unless otherwise specified by the purchaser. Compression sleeves shall be field trimmed to meet required allowable axial movement as set forth by system requirements. Spherical washers can also be furnished (upon request) to combat any potential “nut to plate” binding during offset. **Consult the systems engineer for proper sleeve lengths prior to system operation.**

**Important Control Rod Considerations** — The number of rods, control rod diameters and control rod plate thicknesses are important considerations when specifying control units for an application. As a minimum, specifying engineers or purchasers shall follow the guidelines as set forth in Appendix C of the Fluid Sealing Association's Rubber Expansion Joint Division Technical Handbook (Sixth Edition). PROCO engineers its control unit assemblies to system requirements. Our designs incorporate an allowable stress of 65% of material yield for each rod and plate (rod and plate material to be specified by purchaser). Therefore, it is important to provide pressure and temperature ratings to PROCO when requesting control units for rubber expansion joints. It is also important to provide adjacent mating flange thickness or mating specifications to insure correct rod lengths are provided.

Toll Free Phone ..... (800) 344-3246  
International Calls ..... (209) 943-6088  
Facsimile ..... (209) 943-0242  
E-mail ..... sales@procoproducts.com  
Web Site ..... <http://www.procoproducts.com>

# COMPRESSION SLEEVES

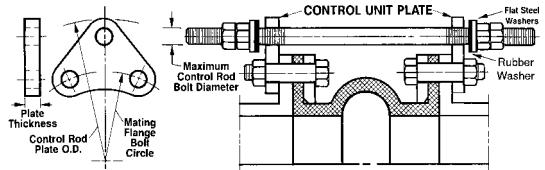

**Table 5: Control Unit Plate Detail** See Notes Below

NOMINAL SIZE Inch / (mm)	CONTROL ROD <sup>1</sup> PLATE O.D. Inch / (mm)	MAXIMUM <sup>2</sup> PLATE THK Inch / (mm)	MAXIMUM <sup>3</sup> ROD DIAMETER Inch / (mm)
1	(25)	8.375 (212.7)	0.625 (15.9)
1.25	(32)	8.750 (222.3)	0.625 (15.9)
1.5	(40)	9.125 (231.8)	0.625 (15.9)
2	(50)	10.125 (257.2)	0.625 (15.9)
2.5	(65)	11.125 (282.6)	1.000 (25.4)
3	(80)	11.625 (295.3)	1.000 (25.4)
3.5	(90)	12.625 (320.7)	1.000 (25.4)
4	(100)	13.125 (333.4)	1.000 (25.4)
5	(125)	14.125 (358.8)	1.000 (25.4)
6	(150)	15.125 (384.2)	1.000 (25.4)
8	(200)	19.125 (485.8)	1.000 (25.4)
10	(250)	21.625 (549.3)	1.000 (25.4)
12	(300)	24.625 (625.5)	1.000 (25.4)
14	(350)	26.625 (676.3)	1.000 (25.4)
16	(400)	30.125 (765.2)	1.250 (31.8)
18	(450)	31.625 (803.3)	1.250 (31.8)
20	(500)	34.125 (866.8)	1.250 (31.8)
22	(550)	36.125 (917.6)	1.250 (31.8)
24	(600)	38.625 (981.1)	1.250 (31.8)
26	(650)	40.875 (1038.2)	1.250 (31.8)
28	(700)	44.125 (1120.8)	1.500 (38.1)
30	(750)	46.375 (1177.9)	1.500 (38.1)
32	(800)	49.375 (1254.1)	1.500 (38.1)
34	(850)	52.375 (1330.3)	1.750 (44.5)
36	(900)	54.625 (1387.5)	1.750 (44.5)
38	(950)	57.375 (1457.3)	1.750 (44.5)
40	(1000)	58.375 (1482.7)	1.500 (38.1)
42	(1050)	61.625 (1565.3)	1.500 (38.1)
44	(1100)	63.875 (1622.4)	1.750 (44.5)
46	(1150)	65.875 (1673.2)	1.750 (44.5)
48	(1200)	68.125 (1730.4)	1.750 (44.5)
50	(1250)	70.375 (1787.5)	1.750 (44.5)
52	(1300)	73.625 (1870.1)	2.000 (50.8)
54	(1350)	75.875 (1927.2)	2.000 (50.8)
56	(1400)	78.375 (1990.7)	2.000 (50.8)
58	(1450)	80.625 (2047.9)	2.000 (50.8)
60	(1500)	82.625 (2098.7)	2.000 (50.8)
66	(1650)	89.625 (2276.5)	2.000 (50.8)
68	(1700)	91.875 (2333.6)	2.000 (50.8)
72	(1800)	96.125 (2441.6)	2.000 (50.8)
78	(2000)	103.125 (2619.4)	2.000 (50.8)
84	(2150)	109.875 (2790.8)	2.250 (57.2)
90	(2300)	117.125 (2975.0)	2.500 (63.5)
96	(2450)	124.625 (3165.9)	2.750 (69.9)
102	(2500)	131.375 (3336.5)	2.500 (63.5)
108	(2750)	138.125 (3508.4)	2.500 (63.5)
120	(3050)	152.125 (3864.0)	2.500 (63.5)
132	(3350)	166.625 (4232.2)	2.500 (63.5)
144	(3650)	180.750 (4591.1)	2.500 (63.5)

Also available with spherical washer

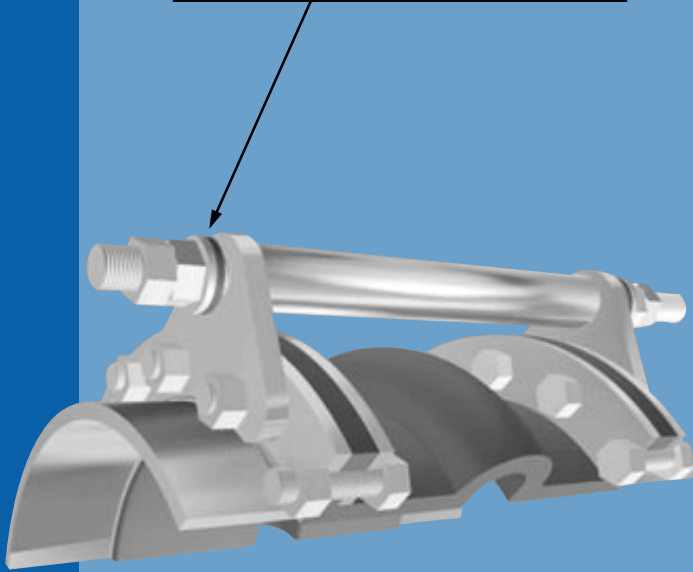
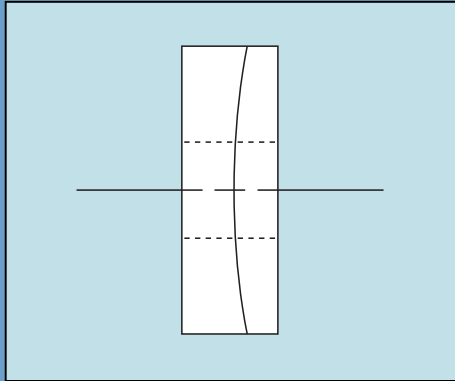

Figure 3: Compression Sleeves

**Metric Conversion: Nominal I.D.: in. x 25 = mm; Dimensions: in. x 25.4 = mm; Pressure: PSIG x .069 = Bar**

Number of Control Units is dependent upon pressure and temperature of system. Refer to Fluid Sealing Association's - REJ Division Manual, Appendix C (Sixth Edition) for **minimum** number of control units (per pressure rating) required for a rubber expansion joint when specified.

Values listed in this table are maximum values based on PROCO'S engineering data.

1. Control rod plate O.D. installed dimension is based on a **maximum** O.D. PROCO would supply. (Figures 2 and 3.)

2. Plate thickness is based on a **maximum** width PROCO would use to design a control rod plate.

3. Control rod diameter is based on a **maximum** diameter PROCO would use to design a control rod.

# Series 230 Drilling Chart

Split Retaining Ring

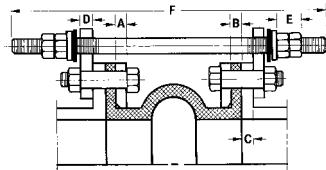
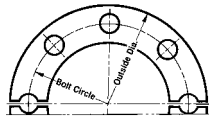

- A - Retaining Ring Thickness
- B - Rubber Flange Thickness
- C - Adjacent Mating Flange Thickness
- D - Control Unit Plate Thickness
- E - Double Nut Thickness is determined by Control Rod Diameter
- F - Control Rod Bolt Length is determined by A through E + OAL<sup>1</sup>

**Table 6: Standard Drilling for PROCO Series 230/220 Rubber Expansion Joints**      **Thickness of Materials for PROCO Series 230/220 Rubber Expansion Joints**

NOMINAL PIPE SIZE EXPANSION JOINT I.D. Inch / (mm)	125/150# Flange Dimensions <sup>2</sup>				Material Thickness <sup>3</sup> for Bolt Length Requirements			
	FLANGE O.D. Inch / (mm)	BOLT CIRCLE Inch / (mm)	NO. OF HOLES	SIZE OF HOLES	RETAINING RING THICKNESS Inch / (mm)	RUBBER FLANGE THICKNESS Inch / (mm)	ADJACENT MATING FLANGE THICKNESS	MAX. CONTROL <sup>3</sup> ROD PLATE THICKNESS Inch / (mm)
1 (25)	4.25 (107.95)	3.13 (79.50)	4	0.625 (15.9)	0.375 (9.53)	0.472 (11.99)	C U S T O M E R	0.625 (15.9)
1.25 (32)	4.63 (117.60)	3.50 (88.90)	4	0.625 (15.9)	0.375 (9.53)	0.472 (11.99)		0.625 (15.9)
1.5 (40)	5.00 (127.00)	3.88 (98.55)	4	0.625 (15.9)	0.375 (9.53)	0.472 (11.99)		0.375 (9.5)
2 (50)	6.00 (152.40)	4.75 (120.65)	4	0.750 (19.1)	0.375 (9.53)	0.472 (11.99)		0.500 (12.7)
2.5 (65)	7.00 (177.80)	5.50 (139.70)	4	0.750 (19.1)	0.375 (9.53)	0.472 (11.99)		0.500 (12.7)
3 (80)	7.50 (190.50)	6.00 (152.40)	4	0.750 (19.1)	0.375 (9.53)	0.472 (11.99)		0.500 (12.7)
3.5 (90)	8.50 (215.90)	7.00 (177.80)	8	0.750 (19.1)	0.375 (9.53)	0.472 (11.99)		0.625 (15.9)
4 (100)	9.00 (228.60)	7.50 (190.50)	8	0.750 (19.1)	0.375 (9.53)	0.472 (11.99)		0.625 (15.9)
5 (125)	10.00 (254.00)	8.50 (215.90)	8	0.875 (22.2)	0.375 (9.53)	0.551 (14.00)		0.500 (12.7)
6 (150)	11.00 (279.40)	9.50 (241.30)	8	0.875 (22.2)	0.375 (9.53)	0.551 (14.00)		0.500 (12.7)
8 (200)	13.50 (342.90)	11.75 (298.45)	8	0.875 (22.2)	0.375 (9.53)	0.630 (16.00)	0.625 (15.9)	
10 (250)	16.00 (406.40)	14.25 (361.95)	12	1.000 (25.4)	0.375 (9.53)	0.630 (16.00)	T O 1.750 (19.1)	
12 (300)	19.00 (482.60)	17.00 (431.80)	12	1.000 (25.4)	0.375 (9.53)	0.748 (19.00)	0.750 (19.1)	
14 (350)	21.00 (533.40)	18.75 (476.25)	12	1.125 (28.6)	0.375 (9.53)	0.866 (22.00)	0.750 (19.1)	
16 (400)	23.50 (596.90)	21.25 (539.75)	16	1.125 (28.6)	0.375 (9.53)	0.866 (22.00)	D E T E R M I N E	
18 (450)	25.00 (635.00)	22.75 (577.85)	16	1.250 (31.8)	0.375 (9.53)	0.866 (22.00)	1.000 (25.4)	
20 (500)	27.50 (698.50)	25.00 (635.00)	20	1.250 (31.8)	0.375 (9.53)	0.984 (25.00)	1.000 (25.4)	
22 (550)	29.50 (749.30)	27.25 (692.15)	20	1.375 (34.9)	0.375 (9.53)	0.984 (25.00)	1.000 (25.4)	
24 (600)	32.00 (812.80)	29.50 (749.30)	20	1.375 (34.9)	0.375 (9.53)	0.984 (25.00)	1.000 (25.4)	
26 (650)	34.25 (869.95)	31.75 (806.45)	24	1.375 (34.9)	0.375 (9.53)	0.984 (25.00)	1.000 (25.4)	
28 (700)	36.50 (927.10)	34.00 (863.60)	28	1.375 (34.9)	0.375 (9.53)	0.984 (25.00)	1.250 (31.8)	
30 (750)	38.75 (984.25)	36.00 (914.40)	28	1.375 (34.9)	0.375 (9.53)	0.984 (25.00)	1.500 (38.1)	
32 (800)	41.75 (1060.45)	38.50 (977.90)	28	1.625 (41.3)	0.375 (9.53)	0.984 (25.00)	1.250 (31.8)	
34 (850)	43.75 (1111.25)	40.50 (1028.70)	32	1.625 (41.3)	0.375 (9.53)	0.984 (25.00)	1.500 (38.1)	
36 (900)	46.00 (1168.40)	42.75 (1085.85)	32	1.625 (41.3)	0.375 (9.53)	0.984 (25.00)	M A T I N G	
38 (950)	48.75 (1238.25)	45.25 (1149.35)	32	1.625 (41.3)	0.375 (9.53)	0.984 (25.00)	1.750 (44.5)	
40 (1000)	50.75 (1289.05)	47.25 (1200.15)	36	1.625 (41.3)	0.375 (9.53)	0.984 (25.00)	1.500 (38.1)	
42 (1050)	53.00 (1346.20)	49.50 (1257.30)	36	1.625 (41.3)	0.375 (9.53)	1.181 (29.99)	1.500 (38.1)	
44 (1100)	55.25 (1403.35)	51.75 (1314.45)	40	1.625 (41.3)	0.375 (9.53)	1.181 (29.99)	1.500 (38.1)	
46 (1150)	57.25 (1454.15)	53.75 (1365.25)	40	1.625 (41.3)	0.375 (9.53)	1.181 (29.99)	1.500 (38.1)	
48 (1200)	59.50 (1511.30)	56.00 (1422.40)	44	1.625 (41.3)	0.375 (9.53)	1.181 (29.99)	1.750 (44.5)	
50 (1250)	61.75 (1568.45)	58.25 (1479.55)	44	1.875 (47.6)	0.375 (9.53)	1.181 (29.99)	F L A N G E	
52 (1300)	64.00 (1625.60)	60.50 (1536.70)	44	1.875 (47.6)	0.375 (9.53)	1.181 (29.99)	1.500 (38.1)	
54 (1350)	66.25 (1682.75)	62.75 (1593.85)	44	2.000 (50.8)	0.375 (9.53)	1.181 (29.99)	1.750 (44.5)	
56 (1400)	68.75 (1746.25)	65.00 (1651.00)	48	1.875 (47.6)	0.375 (9.53)	1.181 (29.99)	2.000 (50.8)	
58 (1450)	71.00 (1803.40)	67.25 (1708.15)	48	1.875 (47.6)	0.375 (9.53)	1.181 (29.99)	2.000 (50.8)	
60 (1500)	73.00 (1854.20)	69.25 (1758.95)	52	2.000 (50.8)	0.375 (9.53)	1.181 (29.99)	2.000 (50.8)	
66 (1650)	80.00 (2032.00)	76.00 (1930.40)	52	2.000 (50.8)	0.375 (9.53)	1.181 (29.99)	2.000 (50.8)	
68 (1700)	82.25 (2089.15)	78.25 (1987.55)	56	2.000 (50.8)	0.375 (9.53)	1.181 (29.99)	T H I C K N E S	
72 (1800)	86.50 (2197.10)	82.50 (2095.50)	60	2.000 (50.8)	0.375 (9.53)	1.181 (29.99)	2.000 (50.8)	
78 (1950)	93.00 (2362.20)	89.00 (2260.60)	64	2.125 (53.0)	0.375 (9.53)	1.188 (30.18)	2.000 (50.8)	
84 (2100)	99.75 (2533.65)	95.50 (2425.70)	64	2.250 (57.2)	0.375 (9.53)	1.188 (30.18)	2.250 (57.2)	
90 (2250)	106.50 (2705.10)	102.00 (2590.80)	68	2.375 (60.3)	0.375 (9.53)	1.188 (30.18)	2.500 (63.5)	
96 (2400)	113.25 (2876.55)	108.50 (2755.90)	68	2.500 (63.5)	0.375 (9.53)	1.188 (30.18)	2.750 (69.9)	
102 (2550)	120.00 (3048.00)	114.50 (2908.30)	72	2.625 (66.7)	0.375 (9.53)	1.188 (30.18)	2.500 (63.5)	
108 (2700)	126.75 (3219.45)	120.75 (3067.05)	72	2.625 (66.7)	0.375 (9.53)	1.188 (30.18)	2.500 (63.5)	
120 (3000)	140.25 (3562.35)	132.75 (3371.85)	76	2.875 (73.0)	0.375 (9.53)	1.188 (30.18)	2.500 (63.5)	
132 (3300)	153.75 (3905.25)	145.75 (3705.05)	80	3.125 (79.4)	0.375 (9.53)	1.188 (30.18)	2.500 (63.5)	
144 (3600)	167.25 (4248.15)	158.25 (4019.55)	84	3.375 (85.7)	0.375 (9.53)	1.188 (30.18)	2.500 (63.5)	

Metric Conversion Formula: Nominal I.D.: in. x 25 = mm; Dimensions: in. x 25.4 = mm; Pressure: PSIG x .069 = Bar

- Notes: 1. Control rod length is determined by OAL of rubber expansion joint, rated extension, retaining ring thickness, mating flange thickness and number of nuts. Consult PROCO for rod lengths.
- 2. Flange dimensions shown are in accordance with 125/150 pound standards: ANSI B16.1 AWWA C-207 Tables 1 and 2 Class D; AWWA C-207 Table 3 see Class E. Hole size shown is 1/8" larger than AWWA standard.
- 3. Plate thickness is based on a maximum width PROCO would use to design a control rod plate.

# PROCO

## YOUR EXPANSION JOINT SOURCE



PROCO PRODUCTS, INC. can offer our customers the largest expansion joint product selection available in today's market! Whether it be rubber, molded PFA, fabric or metal expansion joints, PROCO can offer a product to meet your needs. And remember ... if PROCO doesn't have the products needed for your application, nobody does!

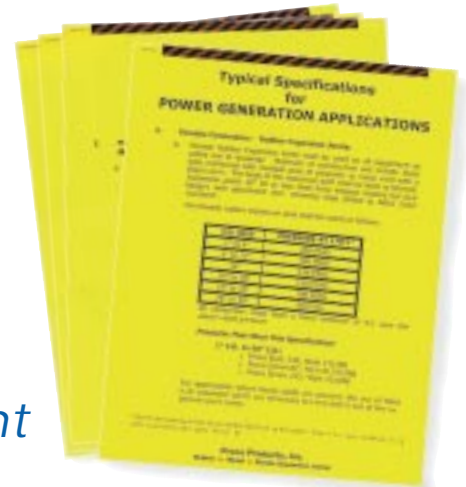

*These PROCO products complement the Series 230/220*

Phone us and get your copies of PROCO's Typical Specifications for your HVAC, Water/Waste Water, Power Generation, and Plastic/FRP/Glass piping applications!



The PROCO Series RE (Eccentric Reducer) Rubber Expansion Joints are in stock in neoprene and butyl elastomers.



The PROCO Series RC (Concentric Reducer) Rubber Expansion Joints are in stock in a multitude of sizes.



The PROCO Series Series 300 Rubber Pipe can be used to eliminate piping vibration.

The PROCO Series 251/BT PTFE and FEP Lined Rubber Expansion Joints are an excellent choice for highly corrosive fluid pipelines.



*Contact PROCO for a complete catalog!*

**Check out our web site!**  
[www.procoproducts.com](http://www.procoproducts.com)

# PROCO PRODUCTS, INC. The Expansion Joint People

"WE COVER THE WORLD"



## NUMBER ONE IN SERVICE!

- Same-day shipping
- Knowledgeable sales staff that has an average of 12 years experience with expansion joints
- Daily UPS® and ROADWAY® pick-up
- Preselected freight carriers to minimize "interline transfer"
- Emergency service for nights, weekends, and even holidays
- Complete expansion joint product line
- Largest inventory in North America



2431 North Wigwam Dr. (95205)  
P.O. Box 590 • Stockton, CA  
95201-0590 • USA

DISTRIBUTED BY:

TOLL-FREE PHONE: (800) 344-3246  
FACSIMILE: (209) 943-0242  
(209) 943-6088  
e-mail: [sales@procoproducts.com](mailto:sales@procoproducts.com)  
web site: <http://www.procoproducts.com>

NATIONWIDE AND CANADA  
INTERNATIONAL