

Sure Flow's World of Foot Valves

Elastic Swing Foot Valve (Flanged)



Page 2

Elastic Hinge Foot Valve (Flanged)



Page 3

Elastic Hinge Foot Valve (Threaded)



Page 4

Silent Seat Foot Valve



Page 5

The Universe of Industrial Valves from Sure Flow



Sure Flow Equipment Inc. - Limited Warranty

All products are warranted to be free of defects in material and workmanship for a period of one year from the date of shipment, subject to below. All custom products are not subject to return, credit or refund.

If the purchaser believes a product to be defective, the purchaser shall:

- (a) Notify the manufacturer, state the alleged defect and request permission to return the product. Merchandise will not be accepted for return without a "Return Code" clearly marked on the outside of the package. Contact the office to obtain a return code.
- (b) If permission is given, return the product with the transportation prepaid. Collect shipments will not be accepted. Goods must be returned prepaid.

If the product is accepted for return and found to be defective, the manufacturer will, at its discretion, either repair or replace the product, f.o.b. factory, within 60 days of receipt, or issue credit for the purchase price.

Other than to repair, replace or credit as described above, purchaser agrees that manufacturer shall not be liable for any loss, costs, expenses or damages of any kind arising out of the product, its use, installation or replacement, labeling, instructions, information or technical data of any kind, description of product or use, sample or model, warnings or lack of any of the foregoing.

NO OTHER WARRANTIES, WRITTEN OR ORAL, EXPRESS OR IMPLIED, INCLUDING THE WARRANTIES OF FITNESS FOR A PARTICULAR PURPOSE AND MERCHANTABILITY, ARE MADE OR AUTHORIZED. NO AFFIRMATION OF ACT, PROMISE, DESCRIPTION OF PRODUCT OR USE OR SAMPLE OR MODEL SHALL CREATE ANY WARRANTY FROM MANUFACTURER, UNLESS SIGNED BY THE PRESIDENT OF MANUFACTURER.

Elastic Swing Foot Valves

Ductile Iron - Flanged

Type FVCEXF-125 Flanged Elastic Swing Foot Valve



The Elastic Swing Foot Valve is suitable for municipal and industrial applications. It is standard with a ductile iron body with flanges which comply with ANSI B16.1; Class 125 or 250. The internal body is epoxy coated. Special coatings are available upon request. The one-piece molded disc has a steel reinforced insert to insure closure. Plus, while in the open position, it will allow 100% uninterrupted flow. The one-piece disc hinge and flapper can be repaired without removal of the valve from the line. The Elastic Swing Foot Valve is designed for continuous flow applications and is not recommended for reciprocating pumps.

The elastic swing foot valve can be installed in a vertical or horizontal pipeline.

Construction

No	Name	Material
1	Cover Bolts	Alloy Steel SAE Grade 5
2	Cover	ASTM A536-60-45-12
3	Disc	BUNA-N w/Steel & Fabric Reinforcement
4	Gasket	Non Asbestos
5	Body	ASTM A536-60-45-12
6	Drain Plug	ASTM A536-60-45-12
7	Screen	1/8" Perforation SS

Operating Pressures and Temperatures

Service	Size	psi	Temp
WOG	2" - 12"	200	150°F
	14" - 24"	150	150°F

Dimensional Data

Inches	Size	A	B	C	D	CV	Shipping Weight lbs
	Prefix						
2	0200	8	10 1/2	3	6 1/8	150	36
2 1/2	0250	8 1/2	11	3	7 1/8	305	46
3	0300	9 1/2	12	3	7 5/8	600	55
4	0400	11 1/2	14	3	9 1/8	955	84
5	0500	13 3/4	16 3/4	4	10 1/8	1400	120
6	0600	15	19 1/2	5	11 1/8	2800	138
8	0800	19 1/2	25	6	13 5/8	5000	300
10	1000	24 1/2	31	7	16 1/8	8000	630
12	1200	27 1/2	35	8	19 1/8	9000	852
14	1400	31	39 1/2	9	21 1/8	10,000	1,032
16	1600	31 15/16	41 7/16	10	23 5/8	15,000	1,308
18	1800	35 15/16	47 7/16	12	25 1/8	18,000	1,740
20	2000	39 15/16	55 7/16	16	27 5/8	28,000	1,890
24	2400	47 15/16	65 7/16	18	32 1/8	40,000	3,120

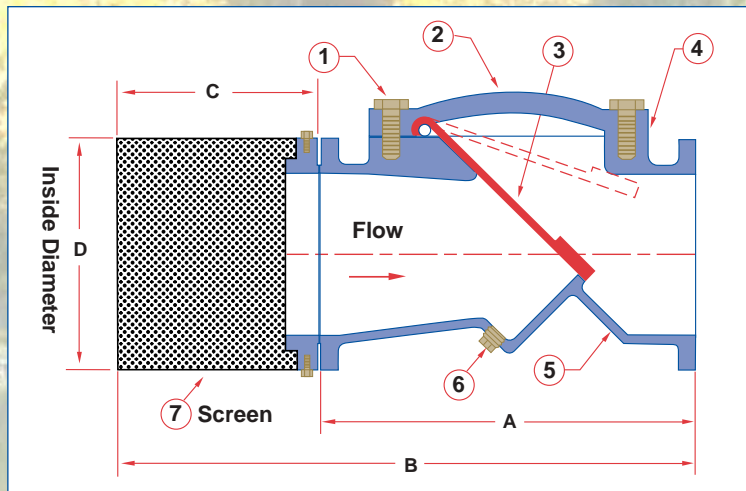

Ordering Information

Example: Include full description

Size (Prefix) Model #
0400 - FVCEXF-125

4" Ductile Iron Flanged
 Elastic Swing Foot Valve,
 Buna-N w/Steel Disc

Notes

Manufacturer reserves the right to modify dimensions, materials, or design. Contact factory for certification.

The Flow Coefficient (Cv) is the number of gallons per minute of water flowing through a given size restriction at a pressure drop of one psi.

NOTE 1

Horizontal Flow: Valve must be installed with cover on top, to insure proper operation.



Elastic Hinge Foot Valves

Cast Steel, Cast Stainless Steel - Flanged

Type FVRF-150CC Carbon Steel Foot Valves and Type FVRF-150SS Stainless Steel Flanged Foot Valves

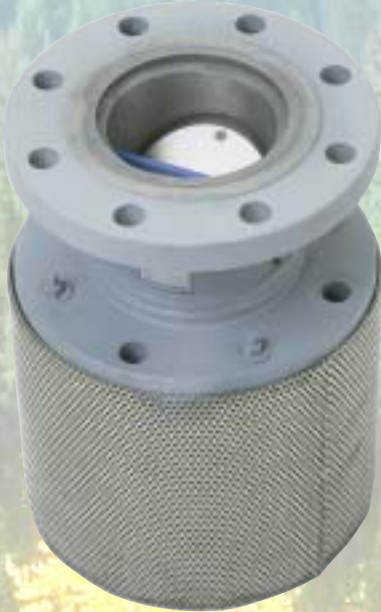

The Elastic Hinge Foot Valve is suitable for municipal and industrial applications.

It is available in Threaded style in sizes from one inch to four inches and in Flanged style in sizes from one inch to twelve inches. Units are supplied standard with Buna seals and 316SS flappers.

The elastic hinge design provides the highest flow factor "Cv" of all the foot valves available from Sure Flow. The Elastic Hinge Foot Valve is seatless, full port, and features a double disc check valve - the next generation of continuous flow internal design that offers high pressure rating and improved flow characteristics.

Standard screen is 0.125" perf. (40% open) with a 6:1 open area ratio. The screen material is 316SS. Other screen openings are available upon request.

NOTE: Foot Valve will operate in either the horizontal or vertical position.

Construction

Model	Body / Internals Materials
FVRF-150CC	Carbon Steel/316SS
FVRF-150SS	316SS

Standard hardware is 316 SS
Standard seal material is Buna-N

Operating Pressures and Temperatures

Type	Size	psi	Temp
WOG	1" - 12"	200	150°F

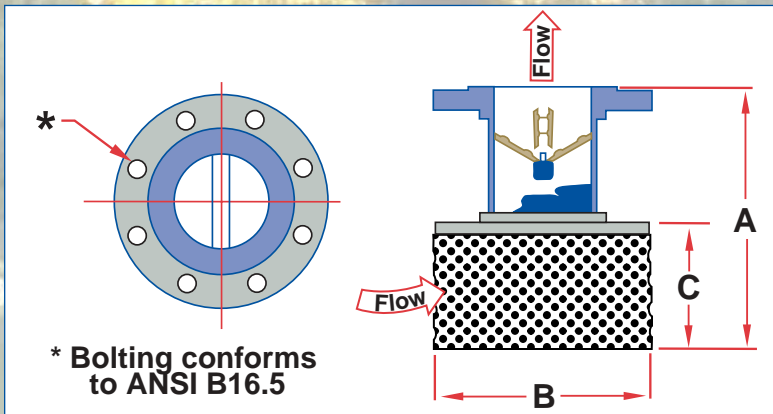

Dimensional Data

Size		A	B	C	Shipping Weight lbs	CV
Inches	Prefix					
1	0100	8 1/4	1 3/4	5	4	37
1 1/4	0125	8 1/4	2	5	5	65
1 1/2	0150	9 3/4	2 3/8	6	7	91
2	0200	10 3/4	2 7/8	7	10	160
2 1/2	0250	13 1/8	3 3/8	8	11	410
3	0300	15 1/2	4 1/8	10	15	620
4	0400	13	9	8	42	965
5	0500	15 1/2	10	10	49	1510
6	0600	17 1/2	12 1/2	11	72	3025
8	0800	24 1/2	15	16	115	5195
10	1000	31 1/2	17 1/2	21	168	7345
12	1200	38 1/2	20 1/2	26	276	9450

Ordering Information

Example: Include full description

Size (Prefix) Model #
0400 - FVRF-150CC

4" Carbon Steel Flanged Foot Valve, Buna-N Seal w/Stainless Steel Disc. Consult factory for optional construction materials. Resilient seating of EPDM, and Teflon.

Notes

Manufacturer reserves the right to modify dimensions, materials, or design. Contact factory for certification.

The Flow Coefficient (Cv) is the number of gallons per minute of water flowing through a given size restriction at a pressure drop of one psi.



Elastic Hinge Foot Valves

Cast Steel, Cast Stainless Steel - Threaded



Type FVRM-150CC Carbon Steel and FVRM-150SS Stainless Steel Male Threaded Foot Valves

The Elastic Hinge Foot Valve is suitable for municipal and industrial applications.

It is available in Threaded style in sizes from one inch to four inches and in Flanged style in sizes from one inch to twelve inches. Units are supplied standard with Buna seals and 316SS flappers.

The elastic hinge design provides the highest flow factor "cv" of all the foot valves available from Sure Flow. The Elastic Hinge Foot Valve is seatless, full port, and features a double disc check valve - the next generation of continuous flow internal design that offers high pressure rating and improved flow characteristics.

Standard screen is 0.125" perf. (40% open) with a 6:1 open area ratio. The screen material is 316SS. Other screen openings are available upon request.

NOTE: Foot Valve will operate in either the horizontal or vertical position.

Construction

Model	Body / Internals Materials
FVRM-150CC	Carbon Steel/316SS
FVRM-150SS	316SS

Standard hardware is 316 SS
Standard seal material is Buna-N

Operating Pressures and Temperatures

Type	Size	psi	Temp
WOG	1" - 4"	200	150°F

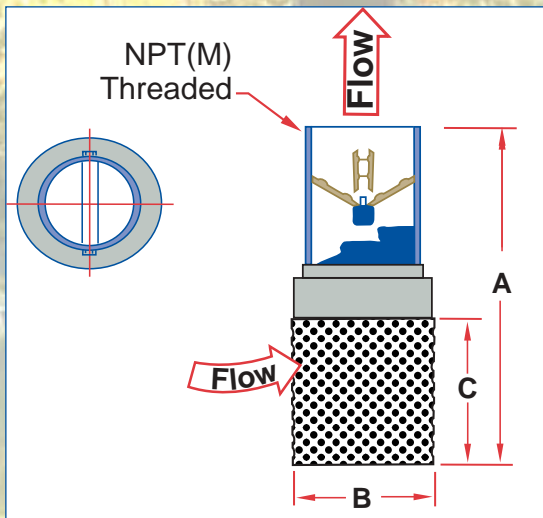

Dimensional Data

Size		A	B	C	Shipping Weight lbs	CV
Inches	Prefix					
1	0100	8 1/4	1 3/4	5	2	37
1 1/4	0125	8 1/4	2	5	2	65
1 1/2	0150	9 3/4	2 3/8	6	2	91
2	0200	10 3/4	2 7/8	7	3	160
2 1/2	0250	13 1/8	3 3/8	8	5	410
3	0300	15 1/2	4 1/8	10	8	620
4	0400	19 1/4	5 1/8	13	12	965

Notes

Manufacturer reserves the right to modify dimensions, materials, or design. Contact factory for certification.

The Flow Coefficient (Cv) is the number of gallons per minute of water flowing through a given size restriction at a pressure drop of one psi.

Ordering Information

Example: Include full description

Size (Prefix) Model #
0400 - FVRM-150CC

4" Carbon Steel Male Threaded Foot Valve, Buna-N Seal w/Stainless Steel Disc. Consult factory for optional construction materials. Resilient seating of EPDM and Teflon.



Silent Seat Foot Valves

Cast Iron - Cast Steel - Stainless Steel - Flanged

Type FV 125 Cast Iron, Type FV150 Cast Steel, Type FV150SS Stainless Steel Foot Valves



Construction

Design of the [Sure Flow Silent Seat Foot Valve](#), available in sizes 2 inches to 30 inches, evolved through a need for a valve that could provide positive sealing actions at various pressure ranges without seat damages, along with silent operation.

The [Sure Flow Silent Seat Foot Valve](#), satisfies these requirements plus low head loss through its full ported area and heavy duty stainless steel basket screening.

The Buna-N O-ring, provides a drop-tight seal. As the pressure increases, the Buna-N O-ring is compressed slightly and the disc makes contact with the metal portion of the valve seat, preventing any further compression of the Buna-N O-ring. The Buna-N O-ring will continue to provide the "drop-tight seating" during the higher pressure ranges without damage from the increased pressure loading.

Standard Features:

- The seating design provides positive shut-off at all pressure ranges without additional loading on the seal.
- Heavy duty stainless steel screening, with flow area 3 to 4 times that of pipe area.
- Silent operation, by design of disc, stroke and linear closing characteristics.
- Cast iron, 125 lb ANSI Standard.

Optional Features:

- Available in carbon steel & stainless steel

Ordering Information

Example: Include full description

Size (Prefix) Model #

1200 - FV150

12" Carbon Steel Silent Seat Flanged Foot Valve, Buna-N Seat



A foot valve should be used with basket strainers and check valves.

Notes

Manufacturer reserves the right to modify dimensions, materials, or design. Contact factory for certification.

Foot Valve Assembly

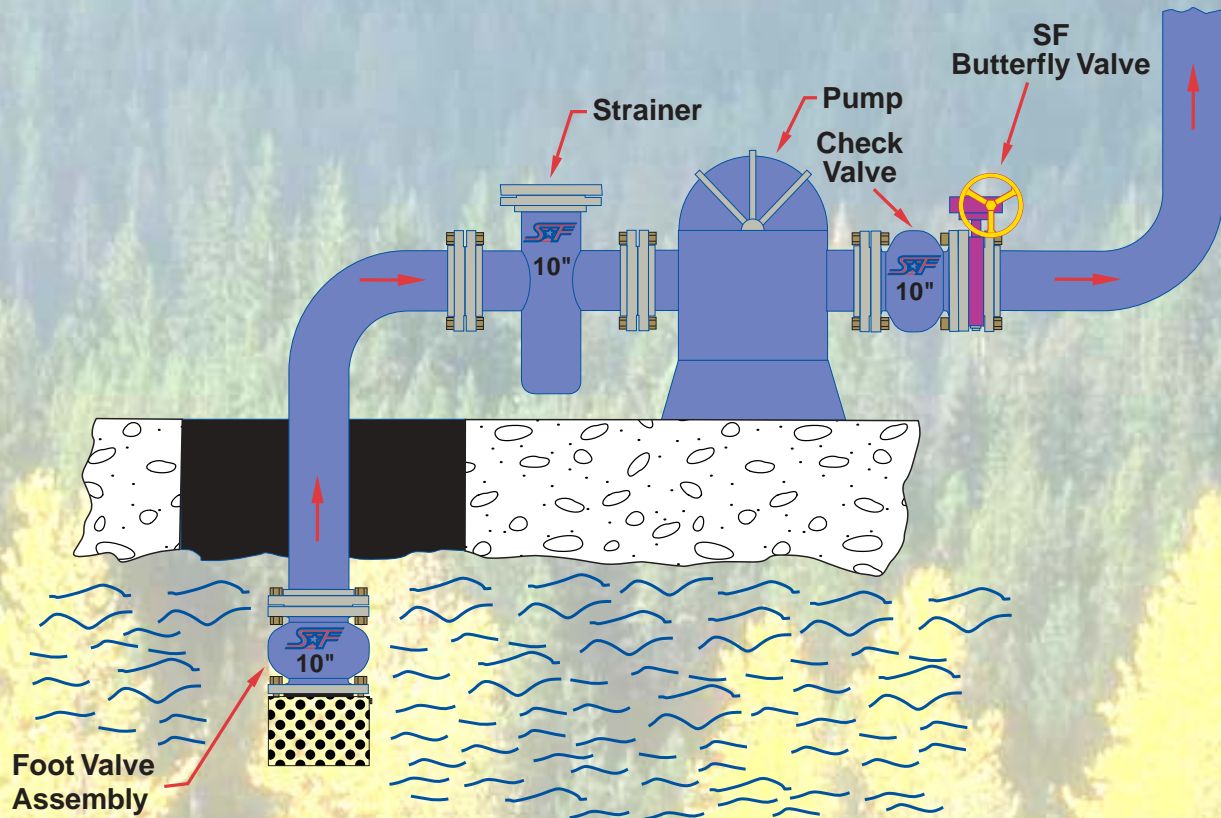

Construction - Cast Steel

No	Name	Material
1	Body Assembly	CF 125 IS/C
2	Quad Ring	Buna-N O-ring
3	Studs	SA 194 B7 Steel
4	Hex Nuts	SA 194 Steel
5	Slip-on Flange	Flat Face ASTM A105
6	Cap Screw	Stainless Steel
7	Screen	Stainless Steel
8	Gasket Ring	Red Rubber

Dimensional Data

Size		A	B	C	D	CV	Shipping Weight lbs
Inches	Prefix						
2	0200	6	3	9 7/16	6	40	25
2 1/2	0250	7	3	10 3/16	7	100	35
3	0300	7 1/2	3	10 11/16	7 1/2	130	45
4	0400	9	3	11 11/16	9	250	70
5	0500	10	4	13 11/16	10	400	90
6	0600	11	5	15 11/16	11	540	110
8	0800	13 1/2	6	19 11/16	13 1/2	1000	180
10	1000	16	7	23 7/16	16	1600	250
12	1200	19	8	28 7/16	19	2200	400

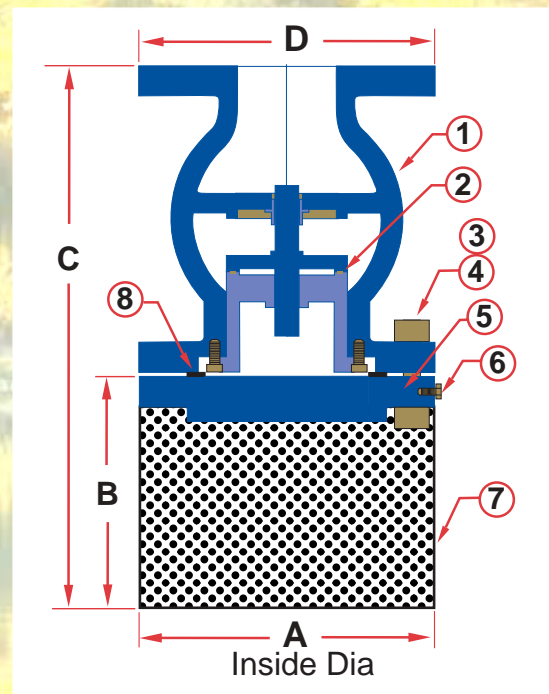

Notes

Manufacturer reserves the right to modify dimensions, materials, or design. Contact factory for certification.

The Flow Coefficient (Cv) is the number of gallons per minute of water flowing through a given size restriction at a pressure drop of one psi.