

Valves for 91000/91400 – Bronze

Single Seat

All dimensions are nominal.
Dimensions in [] are in millimeters.

stem In-To-Close

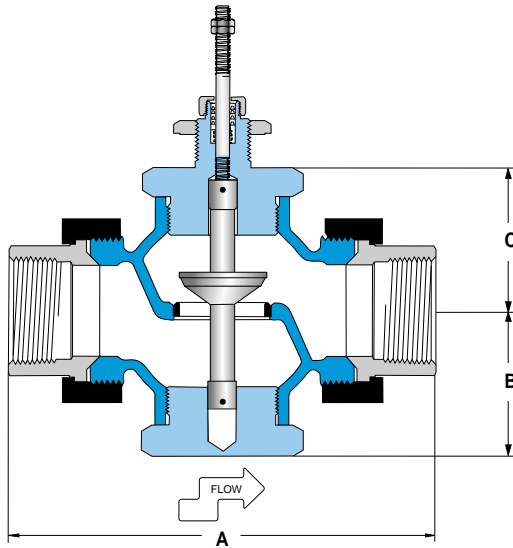

stem In-To-Open

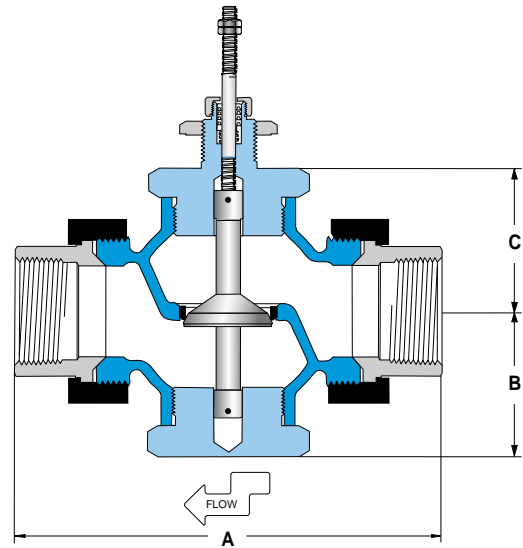

Temperature Regulators

Specifications

Body Material	Trim Material	Trim Style	Connection	Pressure & Temperature Rating
Bronze	Stainless steel	Modified linear	Threaded, malleable iron union ends	250 psi @ 410°F (210°C)

Valve Selection

Valve Number		Connection	Size Nominal Port	C _v	Maximum Inlet (psig)	Dimensions			Approximate Shipping Wt.
In-To-Close Heating	In-To-Open Cooling					A	B	C	
A02	A03	1/2 NPT	1/8"	0.17	250	4.8 [122]	1.8 [46]	1.8 [46]	3.0 lbs [1.35 kg]
A05	A06	1/2 NPT	3/16"	0.35	250	4.8 [122]	1.8 [46]	1.8 [46]	3.0 lbs [1.35 kg]
A08	A09	1/2 NPT	1/4"	0.7	250	4.8 [122]	1.8 [46]	1.8 [46]	3.0 lbs [1.35 kg]
A11	A12	1/2 NPT	3/8"	1.4	250	4.8 [122]	1.8 [46]	1.8 [46]	3.0 lbs [1.35 kg]
A14	A15	1/2 NPT	1/2"	2.8	250	4.8 [122]	1.8 [46]	1.8 [46]	3.0 lbs [1.35 kg]
A19	A22	3/4 NPT	3/4"	5.6	140	5.6 [142]	2.3 [58]	2.3 [58]	4.9 lbs [2.21 kg]
A26	A30	1 NPT	1"	8.4	80	6.0 [152]	2.3 [58]	2.3 [58]	6.0 lbs [2.70 kg]
A36	A41	1 1/4 NPT	1 1/4"	15	50	7.2 [183]	2.6 [66]	2.6 [66]	9.7 lbs [4.37 kg]
A47	A52	1 1/2 NPT	1 1/2"	21	35	7.7 [196]	2.6 [66]	2.6 [66]	10.8 lbs [4.86 kg]
A58	A63	2 NPT	2"	33	20	7.6 [218]	3.1 [79]	3.1 [79]	16.3 lbs [7.34 kg]

Valves for 91000/91400 – Bronze

Double Seat

All dimensions are nominal.
Dimensions in [] are in millimeters.

stem In-To-Close

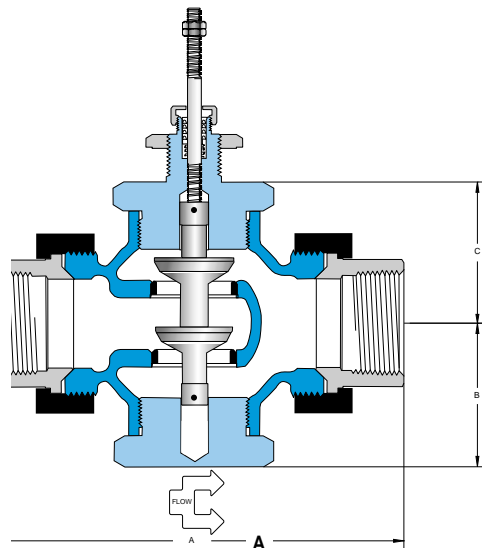

stem In-To-Open

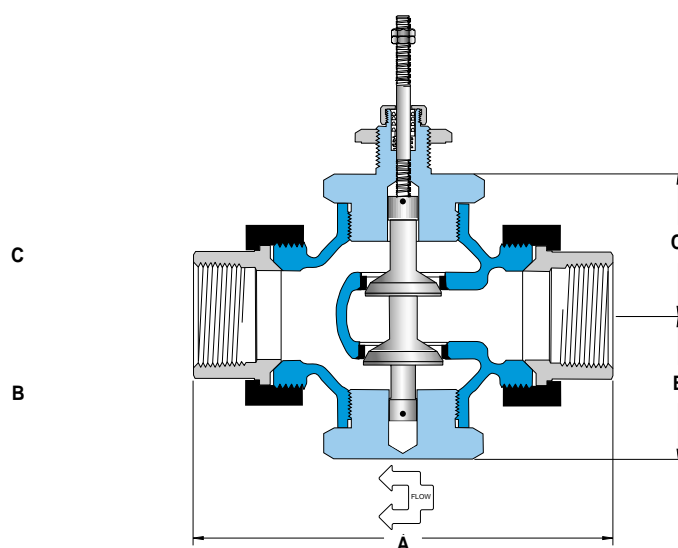

Specifications

Body Material	Trim Material	Trim Style	Connection	Pressure & Temperature Rating
Bronze	Stainless steel	Modified linear	Threaded, malleable iron union ends	250 psi @ 410°F (210°C)

Valve Selection

Valve Number		Size		C _v	Maximum Inlet (psig)	Dimensions			Approximate Shipping Wt.
In-To-Close Heating	In-To-Open Cooling	Connection	Nominal Port			A	B	C	
A21	A24	3/4 NPT	3/4"	8	250	5.6 [142]	2.3 [58]	2.3 [58]	5.0 lbs [2.25 kg]
A29	A33	1 NPT	1"	12	250	6.0 [152]	2.3 [58]	2.3 [58]	6.1 lbs [2.75 kg]
A39	A44	1 1/4 NPT	1 1/4"	21	250	7.2 [183]	2.6 [66]	2.6 [66]	10.1 lbs [4.55 kg]
A50	A55	1 1/2 NPT	1 1/2"	30	250	7.7 [196]	2.6 [66]	2.6 [66]	11.1 lbs [5.00 kg]
A61	A66	2 NPT	2"	47	250	7.6 [218]	3.1 [79]	3.1 [79]	17.0 lbs [7.65 kg]

Valves for 91000/91400 – Cast-Iron

Double Seat

All dimensions are nominal.
Dimensions in [] are in millimeters.

stem In-To-Close

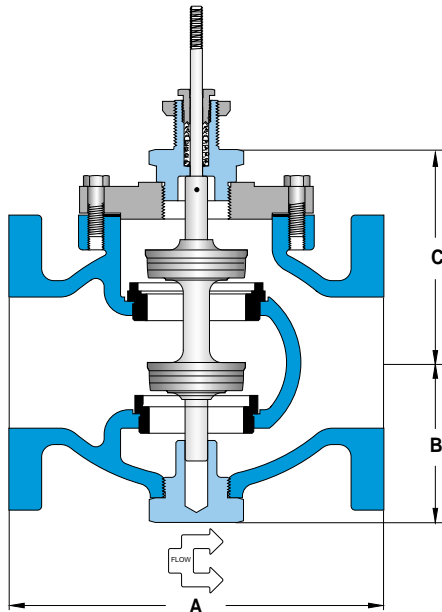

stem In-To-Open

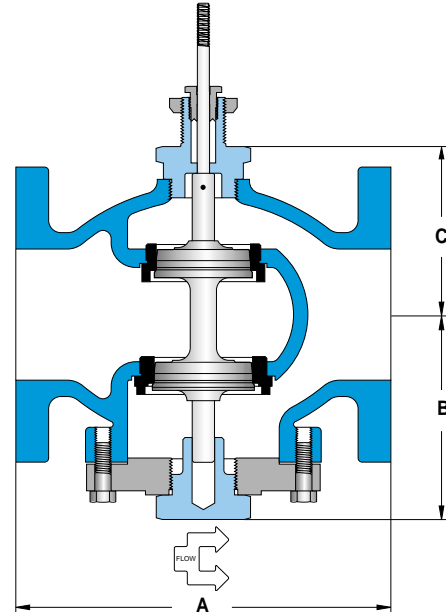

Specifications

Body Material	Trim Material	Trim Style	Connection	Pressure & Temperature Rating
Cast-iron	Stainless steel	Modified linear	Class 125 flanged	125 psi @ 350°F

Valve Selection

Valve Number		Size		C _v	Maximum Inlet (psig)	Dimensions			Approximate Shipping Wt.
In-To-Close Heating	In-To-Open Cooling	Connection	Nominal Port			A	B	C	
B73	B74	2 1/2"	2 1/2"	69	65	7.8 [198]	4.8 [122]	5.4 [137]	45 lbs [20 kg]
B78	B79	3"	3"	90	50	9.0 [229]	5.0 [127]	5.6 [142]	70 lbs [32 kg]
B83	B84	4"	4"	196	40	11.4 [290]	6.3 [160]	6.5 [165]	100 lbs [45 kg]
B88	B89	5"	5"	248	30	12.0 [305]	6.9 [175]	7.3 [185]	155 lbs [70 kg]
B93	B94	6"	6"	340	25	14.1 [358]	7.5 [191]	8.0 [203]	180 lbs [82 kg]

Valves for 91000/91400 – Cast-Steel

Single Seat

All dimensions are nominal.
Dimensions in [] are in millimeters.

stem In-To-Close

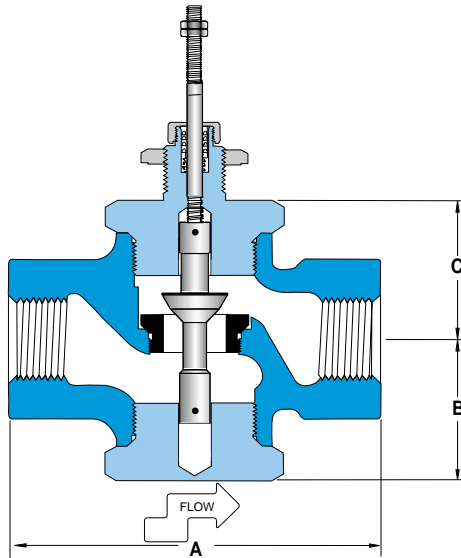

stem In-To-Open

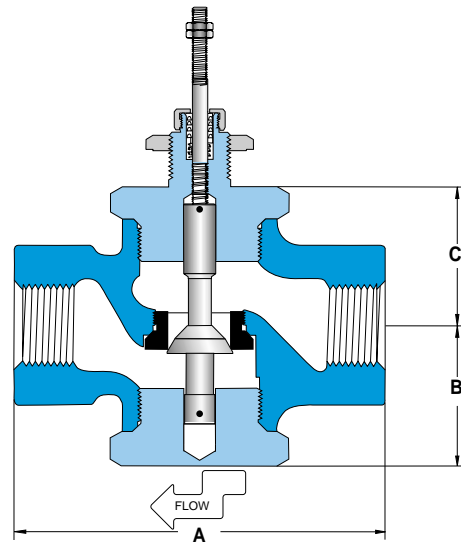

Specifications

Body Material	Trim Material	Trim Style	Connection	Pressure & Temperature Rating
Cast-Steel	Stainless steel	Modified linear	Threaded	250 psi @ 410°F (210°C)

Valve Selection

Valve Number		Connection	Size Nominal Port	C _v	Maximum Inlet (psig)	Dimensions			Approximate Shipping Wt.
In-To-Close Heating	In-To-Open Cooling					A	B	C	
C01	—	3/4 NPT	1/8"	0.17	250	6.0 [152]	2.3 [58]	2.3 [58]	9.2 lbs [4.18 kg]
C02	—	3/4 NPT	3/16"	0.35	250	6.0 [152]	2.3 [58]	2.3 [58]	9.2 lbs [4.18 kg]
C03	—	3/4 NPT	1/4"	0.7	250	6.0 [152]	2.3 [58]	2.3 [58]	9.2 lbs [4.18 kg]
C04	—	3/4 NPT	3/8"	1.4	250	6.0 [152]	2.3 [58]	2.3 [58]	9.2 lbs [4.18 kg]
C05	C15	3/4 NPT	1/2"	2.8	250	6.0 [152]	2.3 [58]	2.3 [58]	9.2 lbs [4.18 kg]
C06	C16	3/4 NPT	3/4"	5.6	140	6.0 [152]	2.3 [58]	2.3 [58]	9.2 lbs [4.18 kg]
C51	—	1 NPT	1/8"	0.17	250	6.0 [152]	2.3 [58]	2.3 [58]	9.2 lbs [4.18 kg]
C52	—	1 NPT	3/16"	0.35	250	6.0 [152]	2.3 [58]	2.3 [58]	9.2 lbs [4.18 kg]
C53	—	1 NPT	1/4"	0.7	250	6.0 [152]	2.3 [58]	2.3 [58]	9.2 lbs [4.18 kg]
C54	—	1 NPT	3/8"	1.4	250	6.0 [152]	2.3 [58]	2.3 [58]	9.2 lbs [4.18 kg]
C55	C65	1 NPT	1/2"	2.8	250	6.0 [152]	2.3 [58]	2.3 [58]	9.2 lbs [4.18 kg]
C56	C66	1 NPT	3/4"	5.6	140	6.0 [152]	2.3 [58]	2.3 [58]	9.2 lbs [4.18 kg]
C57	C67	1 NPT	1"	8.4	80	6.0 [152]	2.3 [58]	2.3 [58]	9.2 lbs [4.18 kg]

Valves for 91000/91400 – Stainless Steel

Single Seat

All dimensions are nominal.
Dimensions in [] are in millimeters.

stem In-To-Close

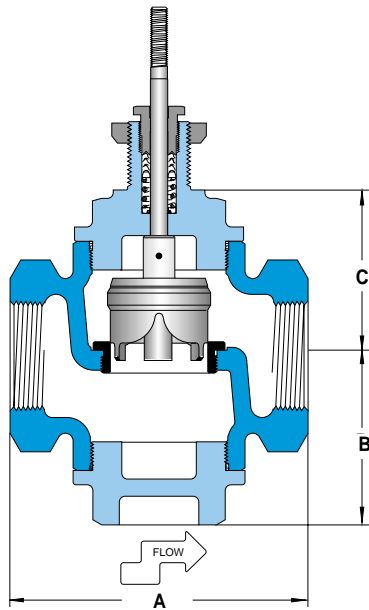

stem In-To-Open

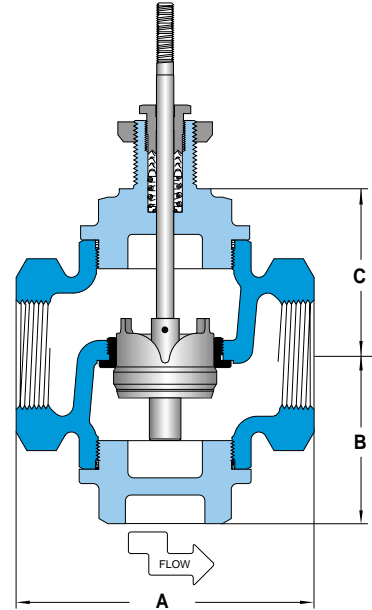

Specifications

Body Material	Trim Material	Trim Style	Connection	Pressure & Temperature Rating
316 stainless steel	Stainless steel	Modified linear	Threaded	250 psi @ 410°F (210°C)

Valve Selection

Valve Number		Connection	Size Nominal Port	C _v	Maximum Inlet (psig)	Dimensions			Approximate Shipping Wt.
In-To-Close Heating	In-To-Open Cooling					A	B	C	
D02	D03	1/2 NPT	1/8"	0.34	250	4.9 [124]	2.9 [74]	3.4 [86]	8.0 lbs [3.64 kg]
D05	D06	1/2 NPT	3/16"	0.76	250	4.9 [124]	2.9 [74]	3.4 [86]	8.0 lbs [3.64 kg]
D08	D09	1/2 NPT	1/4"	1.5	250	4.9 [124]	2.9 [74]	3.4 [86]	8.0 lbs [3.64 kg]
D11	D12	1/2 NPT	3/8"	3.4	250	4.9 [124]	2.9 [74]	3.4 [86]	8.0 lbs [3.64 kg]
D14	D15	1/2 NPT	1/2"	6.0	250	4.9 [124]	2.9 [74]	3.4 [86]	8.0 lbs [3.64 kg]
D19	D22	3/4 NPT	3/4"	8.6	140	4.9 [124]	2.9 [74]	3.4 [86]	8.0 lbs [3.64 kg]
D26	D30	1 NPT	1"	14	60	4.9 [124]	2.9 [74]	3.4 [86]	8.0 lbs [3.64 kg]
D47	D52	1 1/2 NPT	1 1/2"	27	25	6.1 [155]	3.4 [86]	4.0 [102]	15.5 lbs [7.05 kg]
D58	D63	2 NPT	2"	33	15	6.5 [165]	3.8 [97]	4.2 [107]	19.0 lbs [8.64 kg]

Valves for 91000/91400 – Bronze

3-Way

Temperature Regulators

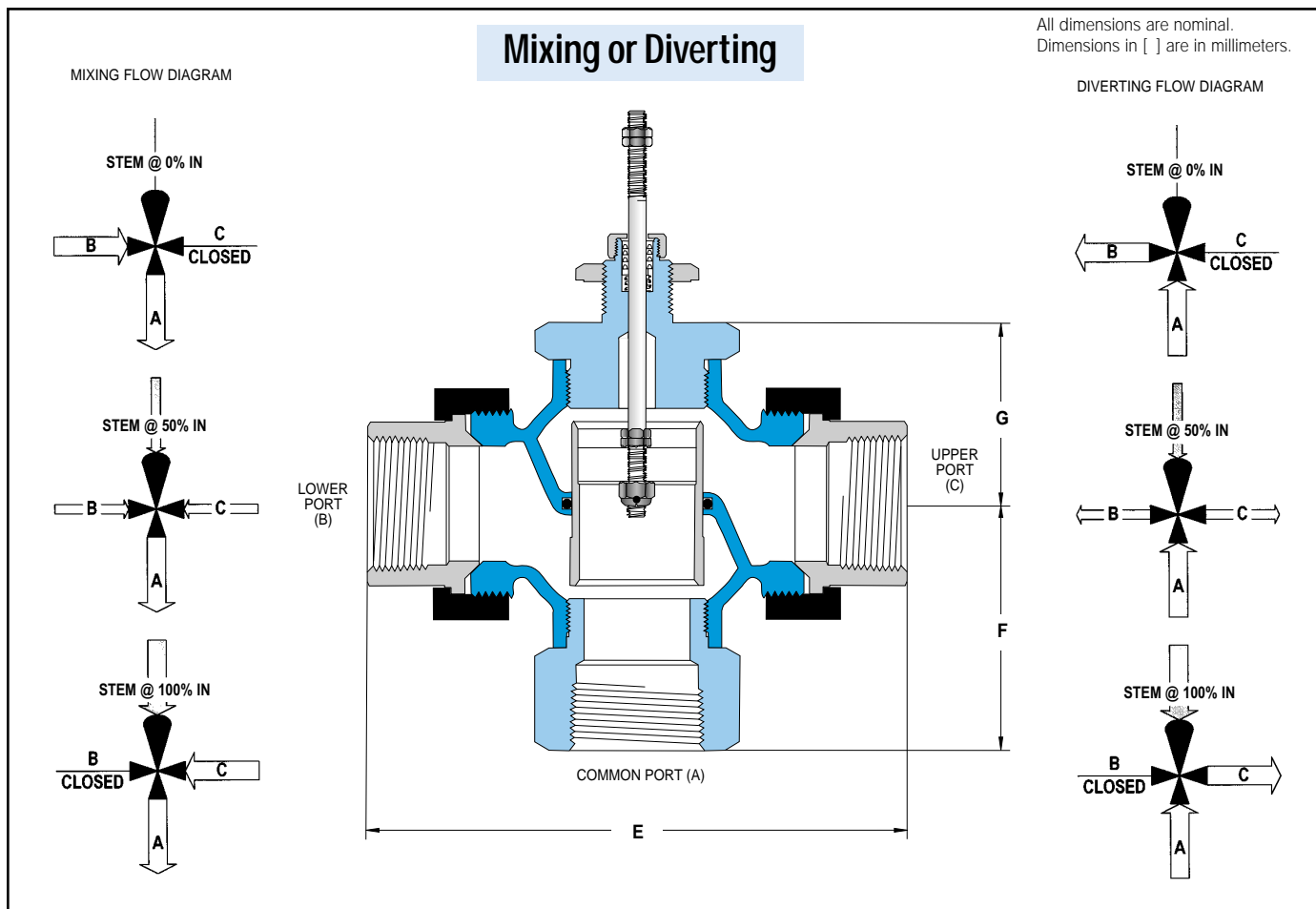

Trerice 3-Way Valves are not designed for use in steam applications.

Specifications

Body Material	Trim Material	Trim Style	Connection	Pressure & Temperature Rating
Bronze	Bronze	Modified linear	Threaded, malleable iron union ends	250 psi @ 300°F (149°C)

Valve Selection

Valve Number	Size		C _v	Maximum Inlet (psig)	Dimensions			Approximate Shipping Wt.
	Connection	Nominal Port			E	F	G	
A18	1/2 NPT	1/2"	2.8	250	4.8 [122]	1.8 [46]	1.8 [46]	2.9 lbs [1.31 kg]
A25	3/4 NPT	3/4"	5.6	250	5.6 [142]	2.3 [58]	2.3 [58]	4.7 lbs [2.12 kg]
A34	1 NPT	1"	8.4	250	6.0 [152]	2.3 [58]	2.3 [58]	5.7 lbs [2.57 kg]
A45	1 1/4 NPT	1 1/4"	15	250	7.2 [183]	2.8 [71]	2.6 [66]	9.5 lbs [4.28 kg]
A56	1 1/2 NPT	1 1/2"	21	250	7.7 [196]	3.5 [89]	2.6 [66]	11.1 lbs [5.00 kg]
A67	2 NPT	2"	33	250	7.6 [218]	4.1 [104]	3.1 [79]	16.7 lbs [7.55 kg]

Valves for 91000/91400 – Cast-Iron

3-Way

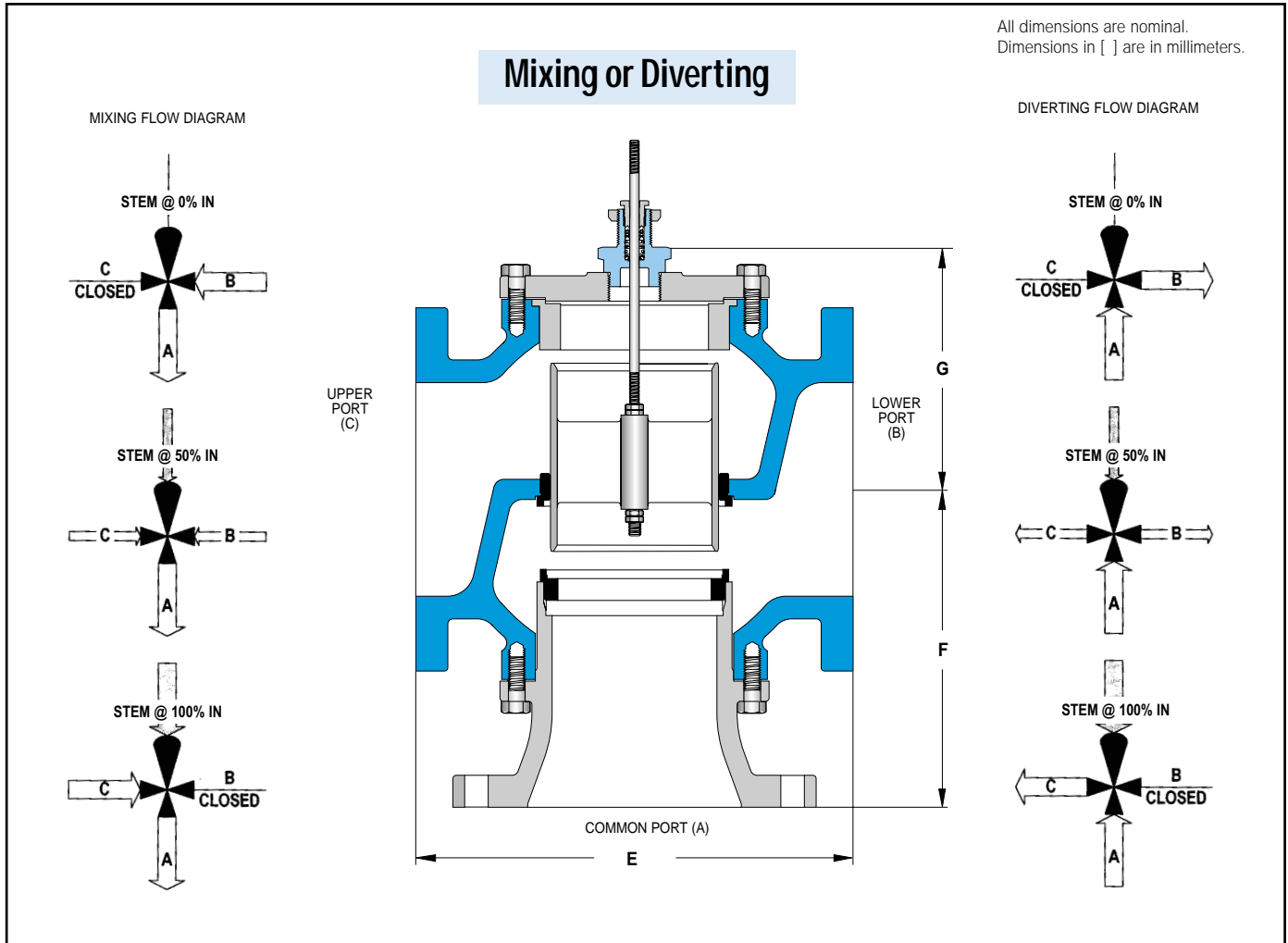

Trerice 3-Way Valves are not designed for use in steam applications.

Specifications

Body Material	Trim Material	Trim Style	Connection	Pressure & Temperature Rating
Cast-Iron	Bronze	Modified linear	Class 125 flanged	125 psi @ 300°F (149°C)

Valve Selection

Valve Number	Size		C _v	Maximum Inlet (psig)	Dimensions			Approximate Shipping Wt.
	Connection	Nominal Port			E	F	G	
B75	2 1/2"	2 1/2"	65	125	9.0 [229]	7.1 [180]	5.2 [132]	62 lbs [28 kg]
B80	3"	3"	77	125	10.0 [254]	8.0 [203]	6.0 [152]	80 lbs [36 kg]
B85	4"	4"	128	125	13.0 [330]	10.0 [254]	6.9 [175]	140 lbs [64 kg]

Valves for 91000/91400 – Stainless Steel

3-Way

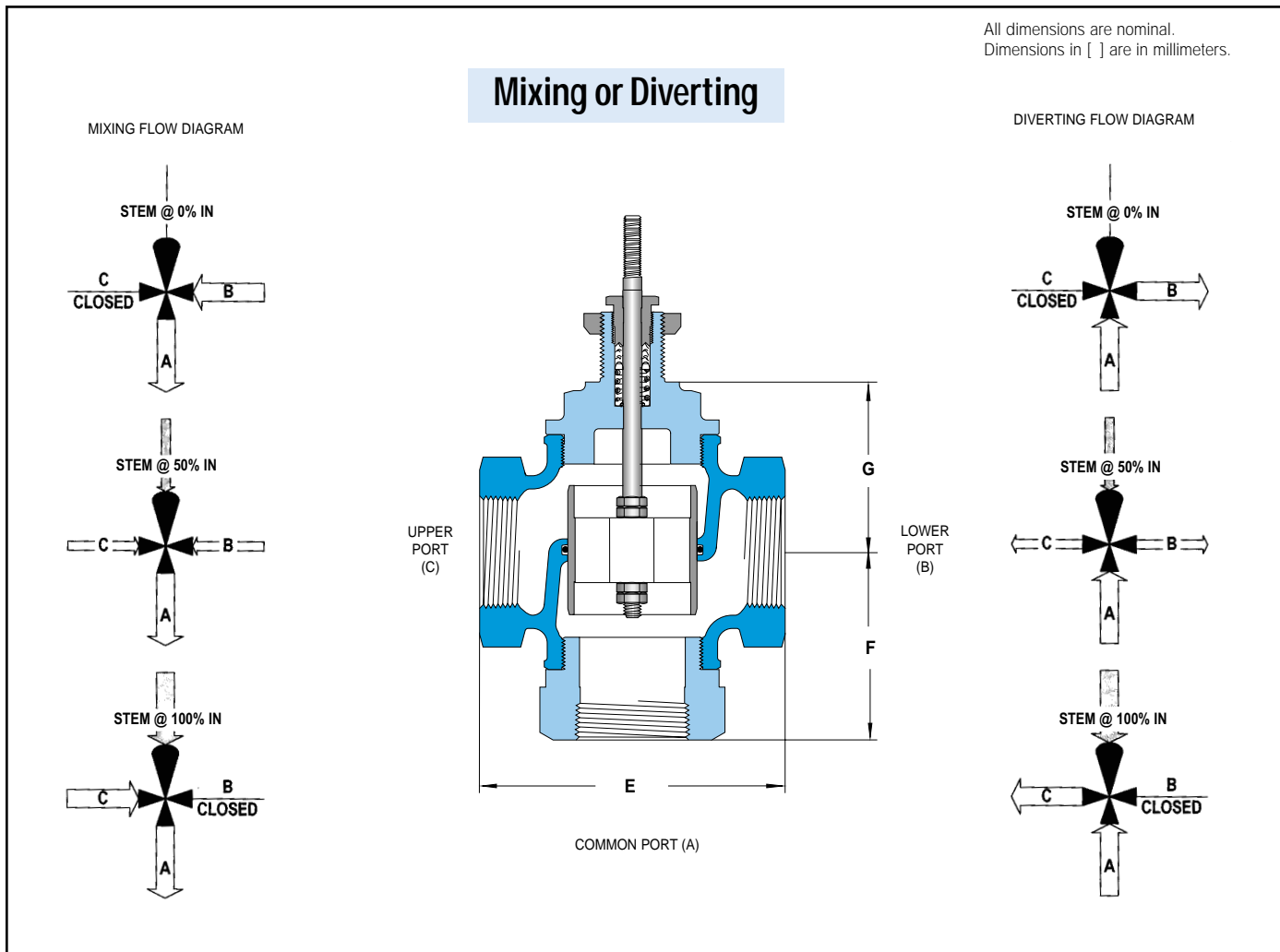

Trerice 3-Way Valves are not designed for use in steam applications.

Specifications

Body Material	Trim Material	Trim Style	Connection	Pressure & Temperature Rating
316 stainless steel	Stainless steel	Modified linear	Threaded	250 psi @ 300°F (149°C)

Valve Selection

Valve Number	Size		C _v	Maximum Inlet (psig)	Dimensions			Approximate Shipping Wt.
	Connection	Nominal Port			E	F	G	
D18	1/2 NPT	1/2"	6	300	4.9 [124]	2.9 [74]	3.4 [86]	7.5 lbs [3.41 kg]
D25	3/4 NPT	3/4"	8	300	4.9 [124]	2.9 [74]	3.4 [86]	7.5 lbs [3.41 kg]
D34	1 NPT	1"	11	300	4.9 [124]	2.9 [74]	3.4 [86]	7.5 lbs [3.18 kg]
D56	1 1/2 NPT	1 1/2"	20	200	6.1 [155]	3.4 [86]	4.0 [102]	15.0 lbs [6.82 kg]
D67	2 NPT	2"	30	100	6.5 [165]	3.8 [97]	4.2 [107]	18.5 lbs [8.41 kg]

Valves for 91600 – Bronze

Single or Double Seat

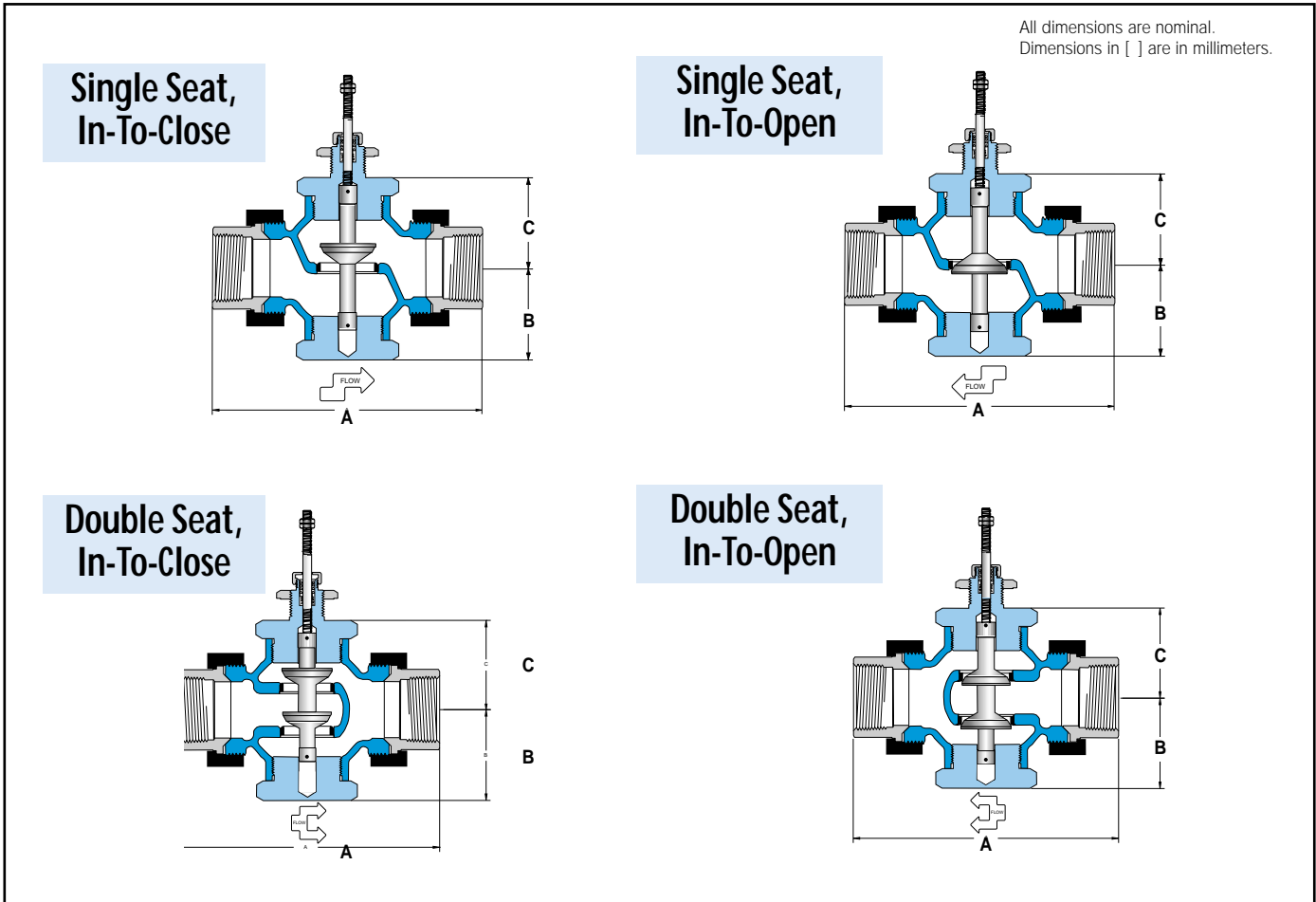

Specifications

Body Material	Trim Material	Trim Style	Connection	Pressure & Temperature Rating
Bronze	Stainless steel	Modified linear	Threaded, malleable iron union ends	250 psi @ 410°F (210°C)

Valve Selection

Valve Number		Connection	Size Nominal Port	No. of Seats	Effective C _v	Max. Inlet (psig)	Dimensions			Approximate Shipping Wt.
In-To-Close Heating	In-To-Open Cooling						A	B	C	
A02	A03	1/2 NPT	1/8"	1	0.12	250	4.8 [122]	1.8 [46]	1.8 [46]	3.0 lbs [1.35 kg]
A05	A06	1/2 NPT	3/16"	1	0.25	250	4.8 [122]	1.8 [46]	1.8 [46]	3.0 lbs [1.35 kg]
A08	A09	1/2 NPT	1/4"	1	0.5	250	4.8 [122]	1.8 [46]	1.8 [46]	3.0 lbs [1.35 kg]
A11	A12	1/2 NPT	3/8"	1	1.0	150	4.8 [122]	1.8 [46]	1.8 [46]	3.0 lbs [1.35 kg]
A14	A15	1/2 NPT	1/2"	1	2.0	100	4.8 [122]	1.8 [46]	1.8 [46]	3.0 lbs [1.35 kg]
A21	A24	3/4 NPT	3/4"	2	5.6	250	5.6 [142]	2.3 [58]	2.3 [58]	5.0 lbs [2.25 kg]
A29	A33	1 NPT	1"	2	8.4	200	6.0 [152]	2.3 [58]	2.3 [58]	6.1 lbs [2.75 kg]
A39	A44	1 1/4 NPT	1 1/4"	2	15	175	7.2 [183]	2.6 [66]	2.6 [66]	10.1 lbs [4.55 kg]
A50	A55	1 1/2 NPT	1 1/2"	2	21	150	7.7 [196]	2.6 [66]	2.6 [66]	11.1 lbs [5.00 kg]
A61	A66	2 NPT	2"	2	33	100	7.6 [218]	3.1 [79]	3.1 [79]	17.0 lbs [7.65 kg]

*The 91600 Safety Actuator has a reduced valve stroke, resulting in a reduced effective C_v as shown.