

# Pressure Regulator 988 Series

for Steam Service



Cast-Iron Construction  
Stainless Steel Seat & Disc  
1/2" to 2" Sizes  
Sensitivity Adjuster

988 pictured

The Trerice Series 988 Pressure Regulator, designed for steam service, provides a sensitive response to reduced pressure changes and delivers the fullest possible volume without an appreciable reduced pressure drop. The 988 includes a spring-loaded diaphragm that can be externally adjusted by the operator to provide a uniform outlet pressure. This regulator is intended for use in testing fixtures, autoclaves, steam tables, vulcanizers, sterilizers and other process applications. It features a "sensitivity adjuster," which can be used to eliminate any vibrating or chattering caused by critical flow requirements.

For optimal performance, the service conditions (medium, flow, temperature, inlet and outlet pressures) of the application must be considered when selecting a regulator. Please refer to the Valve Selection Section of this catalog. Improper application may cause failure of the valve, resulting in possible personal injury or property damage.

## Specifications

<b>Model</b> 988	<b>Diaphragm</b> Laminated bronze	<b>Strainer</b> Stainless steel	<b>Operating Temperature</b> Maximum: 387°F (197°C)
<b>Body</b> Cast-iron	<b>Trim</b> Valve Disc: Stainless steel Seat: Stainless steel	<b>Maximum Inlet Pressure</b> 200 psi	

## How To Order

Sample Order Number: G98808B  
G988 04

Model	Connection Size	Reduced Pressure Range
<b>G988</b>	<b>04</b> 1/2 NPT	<b>A</b> 3 to 15 psi
	<b>06</b> 3/4 NPT	<b>B</b> 10 to 30 psi
	<b>08</b> 1 NPT	<b>C</b> 30 to 140 psi
	<b>10</b> 1 1/4 NPT	<b>D</b> 5 to 40 psi
	<b>12</b> 1 1/2 NPT	<b>E</b> 30 to 100 psi
	<b>16</b> 2 NPT	

1 1/2 & 2 NPT Connection Size only.

# Pressure Regulator 988 Series

for Steam Service

All dimensions are nominal. Dimensions in [ ] are in millimeters.

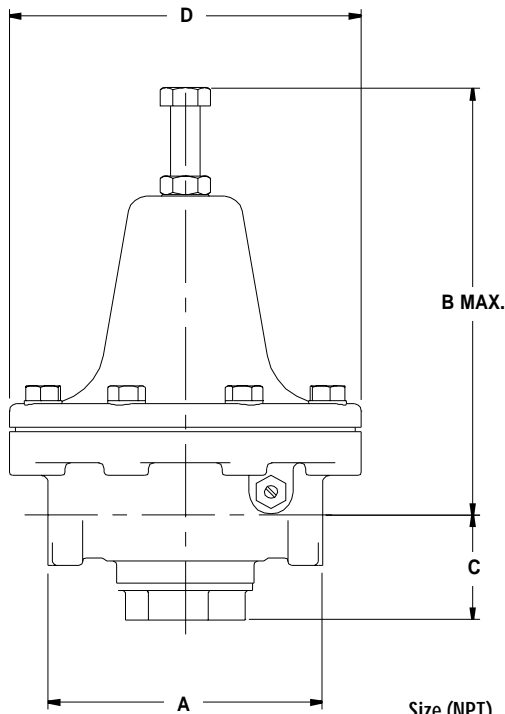

Size (NPT)	A	B	C	D	Approximate Shipping Weight
1/2	4.7 [119]	7.0 [178]	1.9 [48]	6.0 [152]	11 lbs [5.0 kg]
3/4	4.7 [119]	7.0 [178]	1.9 [48]	6.0 [152]	11 lbs [5.0 kg]
1	5.6 [142]	7.5 [191]	2.2 [56]	7.5 [191]	20 lbs [9.1 kg]
1 1/4	5.6 [142]	7.5 [191]	2.2 [56]	7.5 [191]	20 lbs [9.1 kg]
1 1/2	6.6 [168]	11.3 [287]	2.8 [71]	9.0 [229]	40 lbs [18 kg]
2	6.6 [168]	11.3 [287]	2.8 [71]	9.0 [229]	40 lbs [18 kg]

## Valve Capacities

### Steam in Pounds Per Hour (pph)

Inlet Pressure (psig)	Reduced Pressure (psig)	Valve Size (NPT)					
		1/2	3/4	1	1 1/4	1 1/2	2
10	5	27	94	133	146	208	240
20	10	40	142	200	220	312	360
30	20	48	168	237	261	370	428
40	30	54	191	270	297	420	486
	20	67	237	335	368	522	603
50	40	60	210	297	327	464	535
	30	76	270	381	420	595	686
60	50	65	230	324	356	505	583
	40	84	298	421	463	656	758
70	60	70	246	348	382	542	626
	50	92	325	458	504	714	825
80	70	74	262	370	407	577	667
	60	98	348	492	541	766	885

### Steam in Pounds Per Hour (pph)

Inlet Pressure (psig)	Reduced Pressure (psig)	Valve Size (NPT)					
		1/2	3/4	1	1 1/4	1 1/2	2
90	70	104	370	523	575	815	942
	50	129	458	646	711	1008	1164
100	80	110	392	554	610	864	998
	60	139	493	696	766	1085	1252
120	100	122	431	608	670	948	1095
	80	156	554	782	860	1219	1408
140	100	172	610	862	948	1342	1550
	80	194	686	968	1065	1509	1743
160	100	211	748	1056	1162	1645	1900
	90	218	772	1090	1198	1698	1961
180	100	244	862	1218	1340	1898	2192
200	100	270	955	1349	1484	2102	2428

Pressure Regulators & Acc.