

INDUSTRIAL BALL VALVES

2-PC FLANGED END SERIES

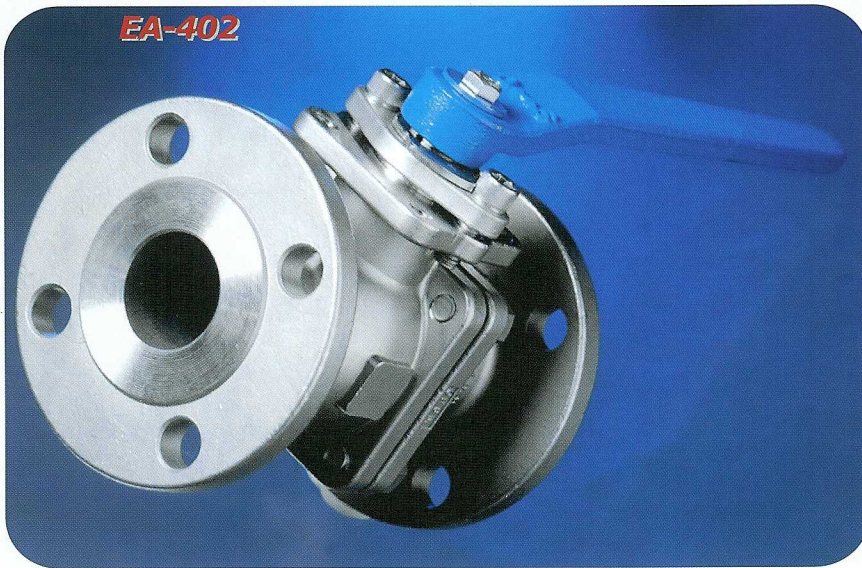
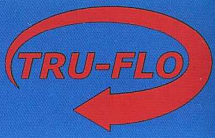

FEATURES/SPECIFICATIONS:

- ASTM 316L Stainless construction
- High quality investment cast body/ends
- 150# flanged ends / 300# flanged ends
- Blowout proof stem design
- 2 pc. Full port design
- Anti-static device
- Lockable handle
- Fire safe option to API 607.1 available
- Gear operator available
- Size: 1/2"-8"
- Options: Carbon Steel
Various Sealing Materials

ITEM	PARTS NAME	MATERIAL			QTY
1	BODY	WCB	CF8	CF8M	1
2	CAP	WCB	CF8	CF8M	1
3	SEATS	PTFE+15% G.F.			2
4	BALL	SUS304	CF8	CF8M	1
5	STEM	SUS304	SUS304	SUS316	1
6	JOINT GASKET	PTFE			1
7	GASKET	PTFE			1
8	SEAL	PTFE			1
910	GLAND BRUSH	PTFE			1
11	GLAND FLANGE	CF8			1
12	STOPPER	SUS304			1
13	HANDLE	DUCTILE IRON			1
14	SNAP RING	STEEL			1
15	BOLTS	SUS304			4,6,8
16	GLAND BOLTS	SUS304			2
17	FLAT WASHER	STEEL			1
18	BOLTS	STEEL			1
19	STATIC DEVICE	SUS304			2
	SPRING	SUS304			2

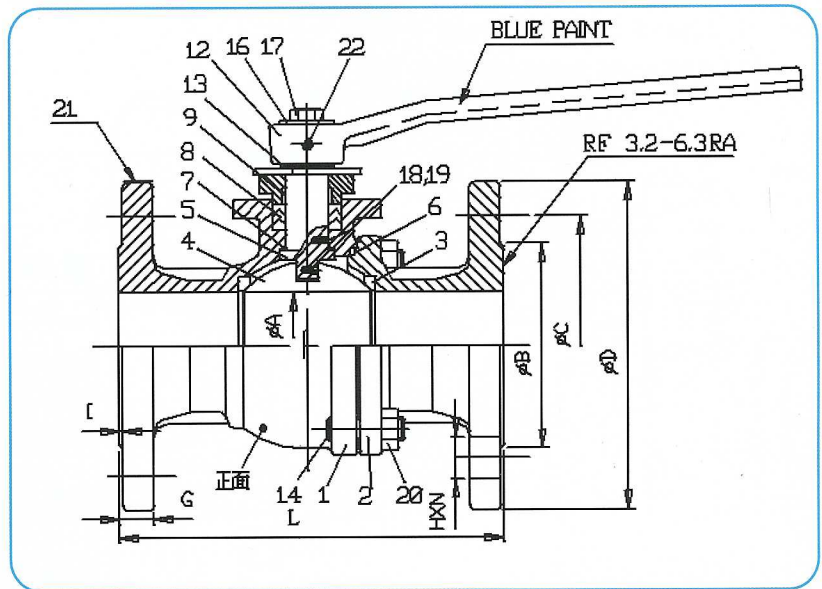

SIZE	A	B	C	D	E	F	G	I	L	H	N	ISO5221
1/2"	16	35	60.5	89	83.7	135	11.1	1.6	108	16	4	F04
3/4"	20	43	70	98	83.7	135	11.1	1.6	117	16	4	F04
1"	25	51	79.5	108	94.7	160	11.1	1.6	127	16	4	F05
1 1/4"	32	64	89	117	98.7	160	12.7	1.6	140	16	4	F05
1 1/2"	38	73	98.5	127	121.3	230	14.3	1.6	165	16	4	F07
2"	50	92	120.5	152	128.7	230	15.9	1.6	178	19	4	F07
2 1/2"	65	105	139.5	178	140.5	230	17.5	1.6	190	19	4	F07
3"	80	127	152.5	190	154	350	19.1	1.6	203	19	4	F10
4"	100	157	190.5	229	170	350	23.9	1.6	229	19	8	F10
5"	125	186	216	254	207	400	23.9	1.6	356	22	8	F10
6"	150	216	241.5	279	272	850	25.4	1.6	394	22	8	F12
8"	200	270	298.5	343	340.5	200	28.6	1.6	457	22	8	F14

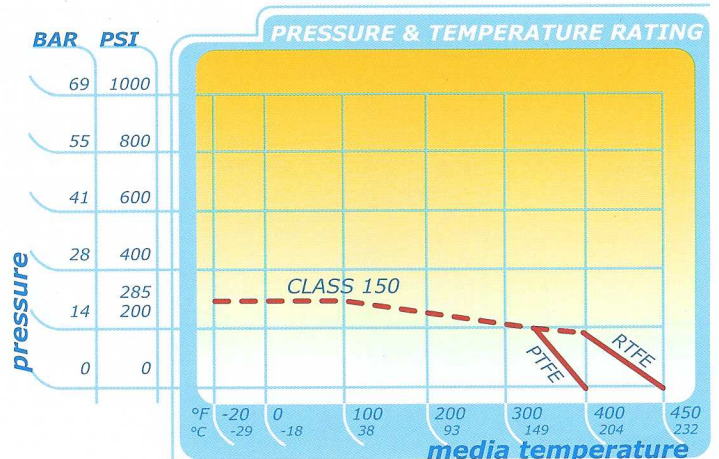

EA-402