

TYLOK PIPE FITTINGS



TYLOK®

INTERNATIONAL, INC.

1061 East 260th Street • Euclid, Ohio 44132 • (216) 261-7310 • 1-800-321-0466
www.tylok.com • email: info@tylok.com

Cullen Crawford introduced the first flareless fitting in the mid 1940's. Well known throughout the fitting industry, Mr. Crawford founded Tylok International, Inc., in the late 1950's. Tylok's product line has been used in applications for automotive, petrochemical, paper/pulp, naval and semi-conductor industries.

This catalog features our pipe fittings as well as general information on how to order. Please call your local Distributor or Tylok International, Inc., if you need further assistance.

Tylok Pipe Fittings are ordered as listed in this catalog by inserting the material code before the part number. Tylok Pipe Fittings can be identified through the part number as to material, pipe size, configuration and thread connection. The part number describes a complete fitting. The size nomenclature to describe a tee fitting is from left (1) to right (2) and down (3). **Special configurations available upon request.**

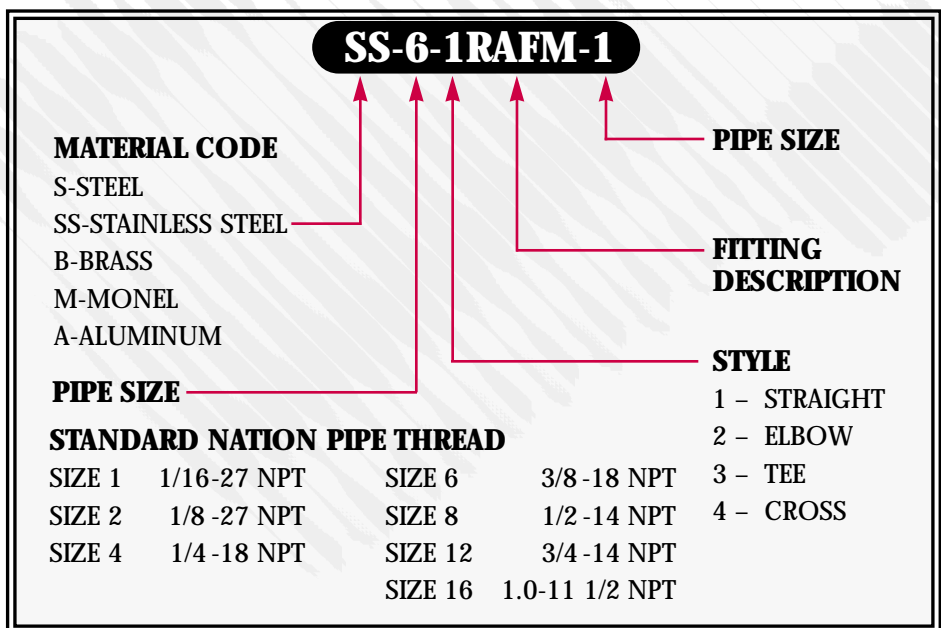

MATERIAL ABBREVIATIONS AND SPECIFICATIONS

Tylok Instrumentation Pipe Fittings are available in the following materials:

- A** - Aluminum **S** - Steel **B** - Brass **SS** - Stainless Steel

Pipe Catalog Raw materials Specifications:

- | | |
|---------------------------|---|
| Brass Forgings | ASTM-B124 Alloy 377 |
| Brass Bar Stock | ASTM-B16 Alloy 360, ASTM-B453 Alloy 345 |
| Stainless Steel Forging | ASME-SA182, ASTM-A182 |
| Stainless Steel Bar Stock | ASME-SA479, ASTM-A276 |
| Steel Bar Stock | ASTM-A108 |

The above materials are considered standard materials of construction. Tylok can supply instrumentation pipe fittings in other materials including Hastelloy C, Monel, Inconel and Titanium. Contact your local Tylok distributor for additional information.

QUALITY MANAGEMENT SYSTEM

QMI has registered Tylok International's Quality Management System to ISO 9001:2000. The quality system complies with the international standard ISO 9001:2000 and its technical equivalent, ANSI/ISO/ASQ Q9001:2000. Tylok strives to continuously improve the effectiveness of the Quality Management System by each member within the organization.



Certificate No. 012106

TYLOK Precision Instrument Pipe Fittings



1FMA

Female To Male Adapter

2

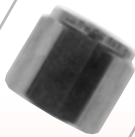

1FPC

Female Pipe Cap

2



1FPHC

Female Pipe Hose Connector

2



1FPRU

Female Pipe Reducer Union

3



1FPU

Female Pipe Union

3



1HLN

Hex Long Nipple

3



1HN

Hex Nipple

4



1HRN

Hex Reducing Nipple

4



1MPHC

Male Pipe Hose Connector

4



1MPP

Male Pipe Plug

5



1RAFM

Reducer Adapter - Female To Male

5



1RBMF

Reducer Bushing - Male To Female

5



2FF

Female Pipe Elbow

6



2FM

Female - Male Pipe Elbow

6



2FMR

Female - Male Reducer Pipe Elbow

6



2MM

Male Pipe Elbow

7



3FFF

All Female Pipe Tee

7



3FFM

Pipe Tee - Female-Female-Male

7



3FMF

Pipe Tee - Female-Male-Female

8



3MMM

All Male Pipe Tee

8

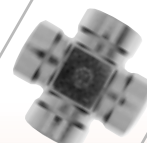

4FPCR

Female Pipe Cross

8

TECHNICAL INFORMATION

Technical Information

9

FEMALE TO MALE ADAPTER

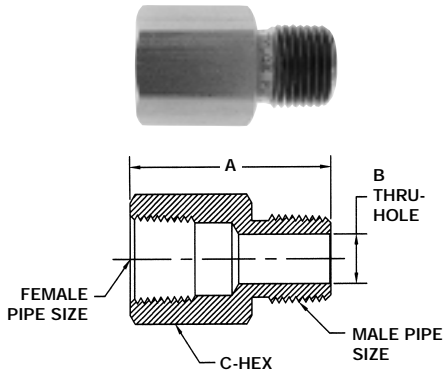

PART NO.	FEMALE PIPE SIZE	MALE PIPE SIZE	A	B THRU-HOLE	C-HEX
1-1FMA	1/16	1/16	1.000	.125	7/16
2-1FMA	1/8	1/8	1.062	.187	9/16
4-1FMA	1/4	1/4	1.375	.281	3/4
6-1FMA	3/8	3/8	1.562	.375	7/8
8-1FMA	1/2	1/2	1.906	.468	1-1/16
12-1FMA	3/4	3/4	1.937	.625	1-1/4
16-1FMA	1	1	2.281	.875	1-5/8

FEMALE PIPE CAP

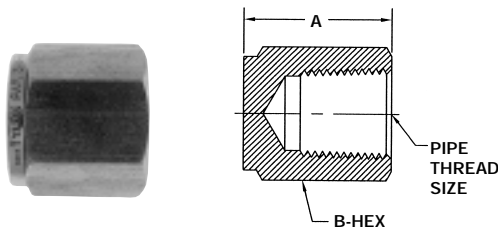

PART NO.	PIPE THREAD SIZE	A	B-HEX
1-1FPC	1/16	.500	7/16
2-1FPC	1/8	.750	9/16
4-1FPC	1/4	.906	3/4
6-1FPC	3/8	1.031	7/8
8-1FPC	1/2	1.343	1-1/16
12-1FPC	3/4	1.437	1-1/4
16-1FPC	1	1.625	1-5/8

FEMALE PIPE HOSE CONNECTOR

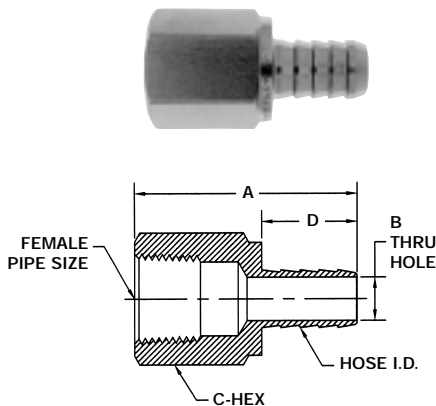

PART NO.	FEMALE PIPE SIZE	HOSE I.D.	A	B THRU-HOLE	C-HEX	D
2-1FPHC-2	1/8	1/8	1.187	.093	9/16	.422
2-1FPHC-3	1/8	3/16	1.344	.125	9/16	.590
2-1FPHC-4	1/8	1/4	1.500	.187	9/16	.790
4-1FPHC-2	1/4	1/8	1.312	.093	3/4	.422
4-1FPHC-3	1/4	3/16	1.465	.125	3/4	.590
4-1FPHC-4	1/4	1/4	1.687	.187	3/4	.790
4-1FPHC-6	1/4	3/8	1.781	.281	3/4	.890
4-1FPHC-8	1/4	1/2	1.781	.406	3/4	.890
6-1FPHC-4	3/8	1/4	1.718	.187	7/8	.790
6-1FPHC-6	3/8	3/8	1.812	.281	7/8	.890
6-1FPHC-8	3/8	1/2	1.812	.406	7/8	.890
8-1FPHC-6	1/2	3/8	2.125	.281	1-1/16	.890
8-1FPHC-8	1/2	1/2	2.078	.406	1-1/16	.890
8-1FPHC-12	1/2	3/4	2.125	.656	1-1/16	.890
12-1FPHC-8	3/4	1/2	2.187	.406	1-1/4	.890
12-1FPHC-12	3/4	3/4	2.187	.656	1-1/4	.890
16-1FPHC-16	1	1	2.312	.906	1-5/8	.890

*NOTE: All dimensions subject to change, to be used for reference only.

FEMALE PIPE REDUCER UNION

PART NO.	FEMALE PIPE SIZE	REDUCED FEMALE PIPE SIZE	A	B THRU-HOLE	C-HEX
2-1FPRU-1	1/8	1/16	1.062	.234	9/16
4-1FPRU-1	1/4	1/16	1.218	.234	3/4
4-1FPRU-2	1/4	1/8	1.218	.328	3/4
6-1FPRU-1	3/8	1/16	1.312	.234	7/8
6-1FPRU-2	3/8	1/8	1.312	.328	7/8
6-1FPRU-4	3/8	1/4	1.375	.421	7/8
8-1FPRU-2	1/2	1/8	1.562	.328	1-1/16
8-1FPRU-4	1/2	1/4	1.750	.421	1-1/16
8-1FPRU-6	1/2	3/8	1.781	.562	1-1/16
12-1FPRU-2	3/4	1/8	1.718	.328	1-1/4
12-1FPRU-4	3/4	1/4	1.812	.421	1-1/4
12-1FPRU-6	3/4	3/8	1.843	.562	1-1/4
12-1FPRU-8	3/4	1/2	2.062	.687	1-1/4
16-1FPRU-2	1	1/8	1.843	.328	1-5/8
16-1FPRU-4	1	1/4	2.000	.421	1-5/8
16-1FPRU-6	1	3/8	2.062	.562	1-5/8
16-1FPRU-8	1	1/2	2.187	.687	1-5/8
16-1FPRU-12	1	3/4	2.250	.890	1-5/8

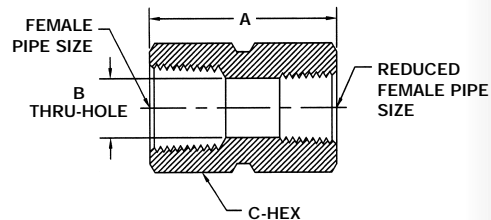
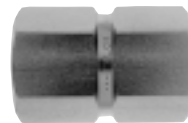

FEMALE PIPE UNION

PART NO.	FEMALE PIPE SIZE	A	B THRU-HOLE	C-HEX
1-1FPU	1/16	.812	.234	7/16
2-1FPU	1/8	.812	.328	9/16
4-1FPU	1/4	1.187	.421	3/4
6-1FPU	3/8	1.312	.562	7/8
8-1FPU	1/2	1.625	.687	1-1/16
12-1FPU	3/4	1.687	.890	1-1/4
16-1FPU	1	2.000	1.125	1-5/8

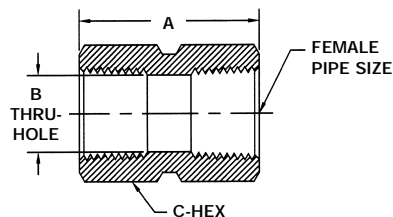
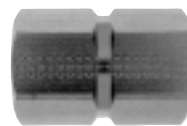

HEX LONG NIPPLE

PART NO.	MALE PIPE SIZE	A	B THRU-HOLE	C-HEX
1-1HLN-★	1/16	★ Made To Order Specify Size	.125	3/8
2-1HLN-★	1/8		.187	7/16
4-1HLN-★	1/4		.281	9/16
6-1HLN-★	3/8		.375	11/16
8-1HLN-★	1/2		.468	7/8
12-1HLN-★	3/4		.625	1-1/16
16-1HLN-★	1		.875	1-3/8

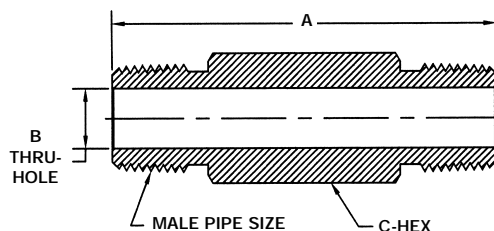

*NOTE: All dimensions subject to change, to be used for reference only.

HEX NIPPLE

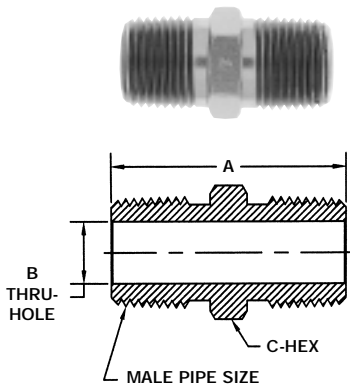

PART NO.	MALE PIPE SIZE	A	B THRU-HOLE	C-HEX
1-1HN	1/16	.937	.125	3/8
2-1HN	1/8	1.000	.187	7/16
4-1HN	1/4	1.375	.281	9/16
6-1HN	3/8	1.406	.375	11/16
8-1HN	1/2	1.781	.468	7/8
12-1HN	3/4	1.812	.625	1-1/16
16-1HN	1	2.281	.875	1-3/8

HEX REDUCING NIPPLE

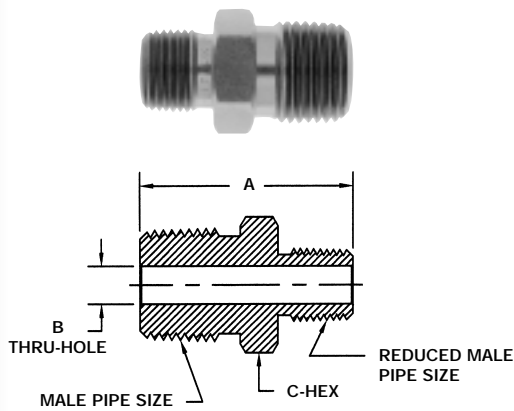

PART NO.	MALE PIPE SIZE	REDUCED MALE PIPE SIZE	A	B THRU-HOLE	C-HEX
2-1HRN-1	1/8	1/16	1.000	.125	7/16
4-1HRN-1	1/4	1/16	1.187	.125	9/16
4-1HRN-2	1/4	1/8	1.187	.187	9/16
6-1HRN-1	3/8	1/16	1.218	.125	11/16
6-1HRN-2	3/8	1/8	1.218	.187	11/16
6-1HRN-4	3/8	1/4	1.406	.281	11/16
8-1HRN-2	1/2	1/8	1.406	.187	7/8
8-1HRN-4	1/2	1/4	1.593	.281	7/8
8-1HRN-6	1/2	3/8	1.625	.375	7/8
12-1HRN-2	3/4	1/8	1.437	.187	1-1/16
12-1HRN-4	3/4	1/4	1.625	.281	1-1/16
12-1HRN-6	3/4	3/8	1.625	.375	1-1/16
12-1HRN-8	3/4	1/2	1.812	.468	1-1/16
16-1HRN-2	1	1/8	1.718	.187	1-3/8
16-1HRN-4	1	1/4	1.906	.281	1-3/8
16-1HRN-6	1	3/8	1.906	.375	1-3/8
16-1HRN-8	1	1/2	2.093	.468	1-3/8
16-1HRN-12	1	3/4	2.093	.625	1-3/8

MALE PIPE HOSE CONNECTOR

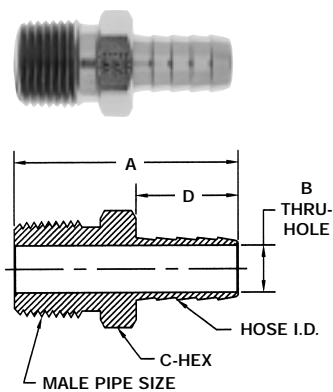

PART NO.	MALE PIPE SIZE	HOSE I.D.	A	B THRU-HOLE	C-HEX	D
2-1MPHC-2	1/8	1/8	1.062	.093	7/16	.422
2-1MPHC-3	1/8	3/16	1.187	.125	7/16	.590
2-1MPHC-4	1/8	1/4	1.462	.187	7/16	.790
4-1MPHC-2	1/4	1/8	1.234	.093	9/16	.422
4-1MPHC-3	1/4	3/16	1.406	.125	9/16	.590
4-1MPHC-4	1/4	1/4	1.609	.187	9/16	.790
4-1MPHC-6	1/4	3/8	1.718	.281	9/16	.890
4-1MPHC-8	1/4	1/2	1.718	.281	9/16	.890
6-1MPHC-4	3/8	1/4	1.609	.187	11/16	.790
6-1MPHC-6	3/8	3/8	1.781	.281	11/16	.890
6-1MPHC-8	3/8	1/2	1.781	.375	11/16	.890
8-1MPHC-6	1/2	3/8	1.953	.281	7/8	.890
8-1MPHC-8	1/2	1/2	1.953	.406	7/8	.890
8-1MPHC-12	1/2	3/4	1.968	.468	7/8	.890
12-1MPHC-8	3/4	1/2	1.968	.406	1-1/16	.890
12-1MPHC-12	3/4	3/4	1.968	.625	1-1/16	.890
16-1MPHC-16	1	1	2.171	.875	1-3/8	.890

*NOTE: All dimensions subject to change, to be used for reference only.

MALE PIPE PLUG

PART NO.	PIPE THREAD	A	B-HEX
1-1MPP	1/16	.750	3/8
2-1MPP	1/8	.750	7/16
4-1MPP	1/4	1.000	9/16
6-1MPP	3/8	1.062	11/16
8-1MPP	1/2	1.312	7/8
12-1MPP	3/4	1.375	1-1/16
16-1MPP	1	1.687	1-3/8

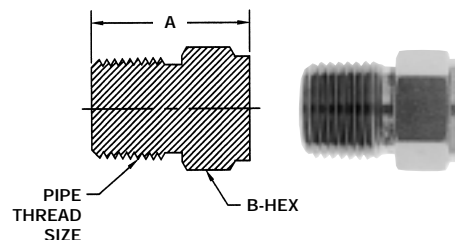

REDUCER ADAPTER - FEMALE TO MALE

PART NO.	FEMALE PIPE SIZE	REDUCED MALE PIPE SIZE	A	B THRU-HOLE	C-HEX
2-1RAFM-1	1/8	1/16	1.093	.125	9/16
4-1RAFM-1	1/4	1/16	1.250	.125	3/4
4-1RAFM-2	1/4	1/8	1.250	.187	3/4
6-1RAFM-1	3/8	1/16	1.437	.125	7/8
6-1RAFM-2	3/8	1/8	1.437	.187	7/8
6-1RAFM-4	3/8	1/4	1.562	.281	7/8
8-1RAFM-2	1/2	1/8	1.687	.187	1-1/16
8-1RAFM-4	1/2	1/4	1.812	.281	1-1/16
8-1RAFM-6	1/2	3/8	1.812	.375	1-1/16
12-1RAFM-2	3/4	1/8	1.812	.187	1-1/4
12-1RAFM-4	3/4	1/4	1.968	.281	1-1/4
12-1RAFM-6	3/4	3/8	1.968	.375	1-1/4
12-1RAFM-8	3/4	1/2	2.062	.468	1-1/4
16-1RAFM-2	1	1/8	2.000	.187	1-5/8
16-1RAFM-4	1	1/4	2.125	.281	1-5/8
16-1RAFM-6	1	3/8	2.125	.375	1-5/8
16-1RAFM-8	1	1/2	2.250	.468	1-5/8
16-1RAFM-12	1	3/4	2.250	.625	1-5/8

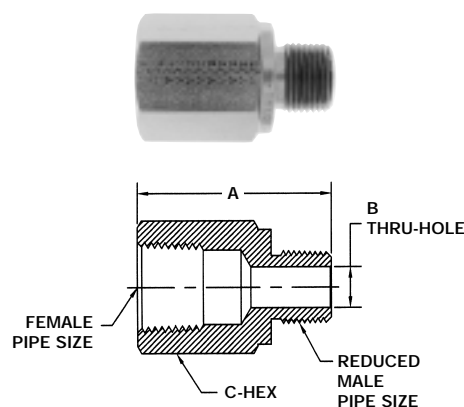

REDUCER BUSHING - MALE TO FEMALE

PART NO.	MALE PIPE SIZE	REDUCED FEMALE PIPE SIZE	A	B THRU-HOLE	C-HEX
2-1RBMF-1	1/8	1/16	1.000	.187	7/16
4-1RBMF-1	1/4	1/16	.812	.234	9/16
4-1RBMF-2	1/4	1/8	1.000	.281	9/16
6-1RBMF-1	3/8	1/16	.843	.234	11/16
6-1RBMF-2	3/8	1/8	.843	.328	11/16
6-1RBMF-4	3/8	1/4	1.125	.375	3/4
8-1RBMF-2	1/2	1/8	1.062	.328	7/8
8-1RBMF-4	1/2	1/4	1.062	.421	7/8
8-1RBMF-6	1/2	3/8	1.312	.468	7/8
12-1RBMF-2	3/4	1/8	1.062	.328	1-1/16
12-1RBMF-4	3/4	1/4	1.062	.421	1-1/16
12-1RBMF-6	3/4	3/8	1.062	.562	1-1/16
12-1RBMF-8	3/4	1/2	1.562	.625	1-1/16
16-1RBMF-2	1	1/8	1.343	.328	1-3/8
16-1RBMF-4	1	1/4	1.343	.421	1-3/8
16-1RBMF-6	1	3/8	1.343	.562	1-3/8
16-1RBMF-8	1	1/2	1.343	.687	1-3/8
16-1RBMF-12	1	3/4	1.750	.875	1-3/8

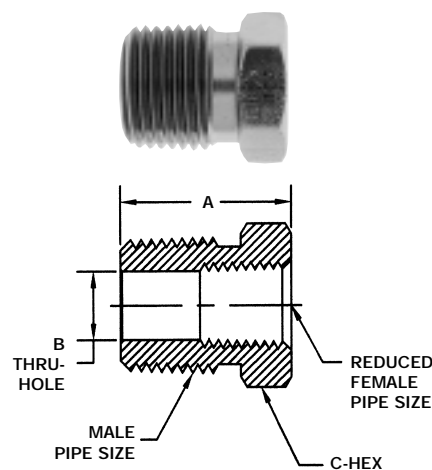

*NOTE: All dimensions subject to change, to be used for reference only.

FEMALE PIPE ELBOW

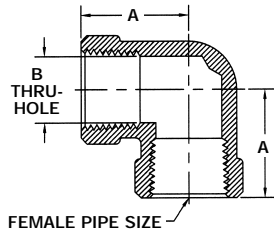

PART NO.	FEMALE PIPE SIZE	A	B THRU-HOLE
1-2FF-1	1/16	.750	.234
2-2FF-2	1/8	.843	.328
4-2FF-4	1/4	.968	.421
6-2FF-6	3/8	1.000	.562
8-2FF-8	1/2	1.125	.687
12-2FF-12	3/4	1.437	.890
16-2FF-16	1	1.625	1.125

FEMALE - MALE PIPE ELBOW

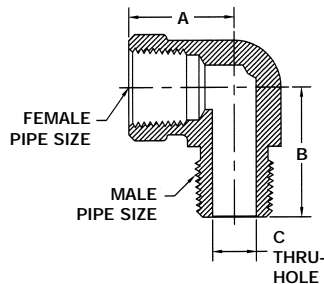

PART NO.	PIPE SIZES	A	B	C THRU-HOLE
1-2FM-1	1/16	.750	.718	.125
2-2FM-2	1/8	.843	.843	.187
4-2FM-4	1/4	.843	1.093	.281
6-2FM-6	3/8	1.000	1.125	.375
8-2FM-8	1/2	1.125	1.375	.468
12-2FM-12	3/4	1.437	1.500	.625
16-2FM-16	1	1.625	1.937	.875

FEMALE - MALE REDUCER PIPE ELBOW

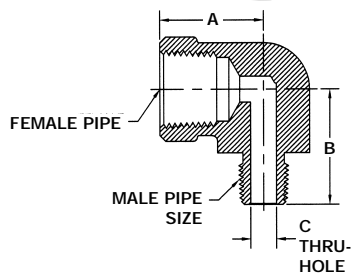

PART NO.	FEMALE PIPE SIZE	MALE PIPE SIZE	A	B	C THRU-HOLE
2-2FMR-1	1/8	1/16	.750	.750	.125
4-2FMR-1	1/4	1/16	.843	.937	.125
4-2FMR-2	1/4	1/8	.843	.937	.187
6-2FMR-1	3/8	1/16	1.000	.937	.125
6-2FMR-2	3/8	1/8	1.000	.937	.187
6-2FMR-4	3/8	1/4	1.125	1.187	.281
8-2FMR-2	1/2	1/8	1.125	1.062	.187
8-2FMR-4	1/2	1/4	1.125	1.250	.281
8-2FMR-6	1/2	3/8	1.125	1.250	.375
12-2FMR-2	3/4	1/8	1.437	1.250	.187
12-2FMR-4	3/4	1/4	1.437	1.375	.281
12-2FMR-6	3/4	3/8	1.437	1.437	.375
12-2FMR-8	3/4	1/2	1.437	1.625	.468
16-2FMR-2	1	1/8	1.625	1.375	.187
16-2FMR-4	1	1/4	1.625	1.625	.281
16-2FMR-6	1	3/8	1.625	1.625	.375
16-2FMR-8	1	1/2	1.625	1.812	.468
16-2FMR-12	1	3/4	1.625	1.875	.625

*NOTE: All dimensions subject to change, to be used for reference only.

MALE PIPE ELBOW

PART NO.	MALE PIPE SIZE	A	B THRU-HOLE
1-2MM-1	1/16	.718	.125
2-2MM-2	1/8	.750	.187
4-2MM-4	1/4	1.000	.281
6-2MM-6	3/8	1.093	.375
8-2MM-8	1/2	1.375	.468
12-2MM-12	3/4	1.500	.625
16-2MM-16	1	1.875	.875

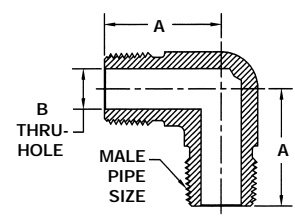

ALL FEMALE PIPE TEE

PART NO.	FEMALE PIPE SIZE	A	B	C THRU-HOLE
1-3FFF-1	1/16	1.500	.750	.234
2-3FFF-2	1/8	1.687	.843	.328
4-3FFF-4	1/4	1.687	.843	.421
6-3FFF-6	3/8	2.000	1.000	.562
8-3FFF-8	1/2	2.250	1.125	.687
12-3FFF-12	3/4	2.625	1.312	.890
16-3FFF-16	1	3.250	1.625	1.125

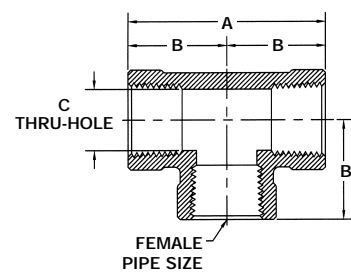

PIPE TEE - FEMALE-FEMALE-MALE

PART NO.	PIPE SIZES	A	B	C	D THRU-HOLE
1-3FFM-1	1/16	1.500	.750	.718	.125
2-3FFM-2	1/8	1.687	.843	.843	.187
4-3FFM-4	1/4	1.875	.937	1.000	.281
6-3FFM-6	3/8	2.000	1.000	1.125	.375
8-3FFM-8	1/2	2.250	1.125	1.375	.468
12-3FFM-12	3/4	2.750	1.375	1.625	.625
16-3FFM-16	1	3.250	1.625	1.937	.875

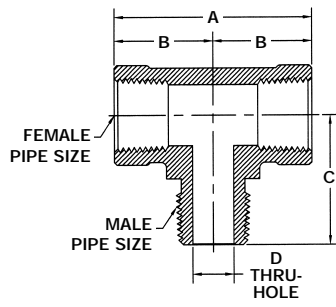

*NOTE: All dimensions subject to change, to be used for reference only.

PIPE TEE - FEMALE-MALE-FEMALE

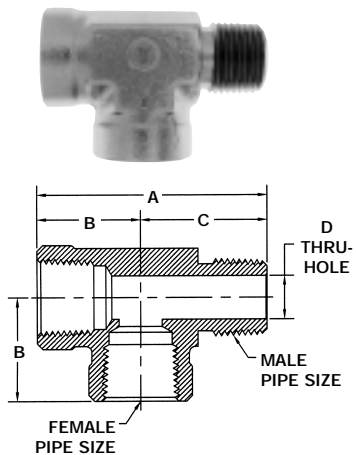

PART NO.	PIPE SIZES	A	B	C	D THRU-HOLE
1-3FMF-1	1/16	1.500	.750	.750	.125
2-3FMF-2	1/8	1.687	.843	.843	.187
4-3FMF-4	1/4	1.890	.843	1.046	.281
6-3FMF-6	3/8	2.125	1.000	1.125	.375
8-3FMF-8	1/2	2.500	1.125	1.375	.468
12-3FMF-12	3/4	2.937	1.437	1.500	.625
16-3FMF-16	1	3.562	1.625	1.937	.875

ALL MALE PIPE TEE

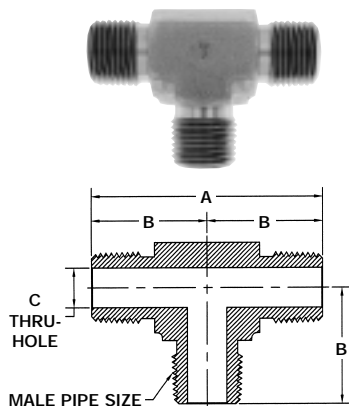

PART NO.	MALE PIPE SIZE	A	B	C THRU-HOLE
1-3MMM-1	1/16	1.437	.718	.125
2-3MMM-2	1/8	1.437	.718	.187
4-3MMM-4	1/4	1.875	.937	.281
6-3MMM-6	3/8	2.000	1.000	.375
8-3MMM-8	1/2	2.750	1.375	.468
12-3MMM-12	3/4	2.750	1.375	.625
16-3MMM-16	1	3.750	1.875	.875

FEMALE PIPE CROSS

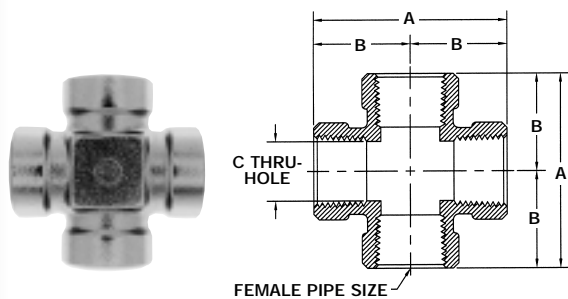

PART NO.	FEMALE PIPE SIZE	A	B	C THRU-HOLE
1-4FPCR	1/16	1.250	.625	.246
2-4FPCR	1/8	1.687	.843	.328
4-4FPCR	1/4	1.687	.843	.421
6-4FPCR	3/8	2.125	1.062	.562
8-4FPCR	1/2	2.250	1.125	.687
12-4FPCR	3/4	2.875	1.437	.890
16-4FPCR	1	3.250	1.625	1.125

*NOTE: All dimensions subject to change, to be used for reference only.

USE/APPLICATION

Tylok Pipe Fittings are designed and manufactured for applications in power, processing and instrumentation. In designing a system incorporating pipe fittings, it is the designer's or user's obligation and responsibility to determine the appropriate fittings to be used for each application, and to insure proper installation and maintenance.

DESIGN/FEATURES

Tylok Pipe Fittings are manufactured to the same high quality standards as other Tylok Fittings. Each fitting is thoroughly cleaned to eliminate system contamination and features an attractive surface finish to enhance the appearance of modern scientific instrumentation and equipment.

PIPE THREAD SPECIFICATIONS

Tylok Pipe Fittings are manufactured from materials meeting applicable ASTM or ASME specifications, with pipe threads which meet or exceed ANSI B1.20.1 requirements. Strict quality control procedures are followed throughout production.

Materials: Brass ■ Steel ■ 316 Stainless Steel
Aluminum ■ Other materials available as special order

Suggest Allowable Working Pressures for Male Pipe Threads

MNPT Size	316 Stainless Steel PSI Rating	Brass PSI Rating	Steel PSI Rating
1/16"	10,100	5,700	10,500
1/8"	9,200	5,300	9,800
1/4"	7,500	4,100	8,000
3/8"	7,250	4,000	7,700
1/2"	6,900	3,900	7,300
3/4"	6,600	3,700	7,000
1"	5,000	2,700	5,000

Suggest Allowable Working Pressures for Female Pipe Threads

FNPT Size	316 Stainless Steel PSI Rating	Brass PSI Rating	Steel PSI Rating
1/16"	6,200	3,500	6,800
1/8"	6,000	3,400	6,600
1/4"	6,100	3,300	6,500
3/8"	5,000	2,700	5,400
1/2"	4,700	2,500	4,800
3/4"	4,300	2,400	4,600
1"	4,100	2,300	4,500

These charts are to be used as a guide only and are based on normal wall thicknesses, used for the various sizes. These ratings may vary widely from effects such as the proper use of sealants, size of stock, temperature, corrosion factors, etc. Therefore, Tylok International, Inc., assumes no responsibility for its accuracy in any individual design.

When using a combination of fittings such as Male Pipe threads with Female Pipe threads, the minimum rating applies.

HEAT TRACEABILITY

Tylok Pipe Fittings can be traced back to the original mill heat from which it was made. Starting with the original billet, the mill creates a certificate which completely describes the chemical and physical makeup. This is useful for providing a method for complete material accountability for the manufacturer and end customer.

TEMPERATURE RATINGS

The standard Tylok Instrumentation Fittings are rated at the following temperatures:

316 Stainless	-325°F to 1200°F	Brass	-40°F to 400°F	Steel ¹	-65°F to 400°F	Aluminum	-40°F to 400°F
	(-198°C to 648°C)		(-40°C to 204°C)		(-54°C to 204°C)		(-40°C to 204°C)

Note: Consideration should be given to maximum temperature ratings if fittings are coated or plated.

¹Special attention should be considered when selecting coated and/or plated materials such as Steel.

INSTALLATION INSTRUCTIONS

Pipe thread connections are very common in today's industry. They are relatively easy to work with because of the common sizes and dimensions throughout manufacturing. It is important to use a thread sealant. These products range from pipe "dopes" to teflon tape, all of which can be purchased through your local Tylok Distributor.



TYLOK PHILOSOPHY

TYLOK HISTORY

Cullen Crawford introduced the first flareless fitting in the mid 1940's. Well known throughout the fitting industry, Mr. Crawford founded Tylok International, Inc., in the late 1950's.

Mr. Crawford responded to the request of the Atomic Energy Commission for a fitting to hold liquid sodium. As a result, he developed the Tylok Standard Tube Fitting, which is still the only four-seal patented design in the industry today.

Manufactured in Euclid, Ohio, the Tylok Standard's unique design eliminates common installation problems and provides unparalleled sealing.

MISSION

It is our mission, at Tylok International, Inc., to continuously strive for and achieve total customer satisfaction with both our products and services.

GOAL

Tylok's aggressive goal is to establish ourselves as an industry leader and expand our market share. This is maintained in every department within the organization. Our "total effort" will guard against losing the personal touch that makes our business enjoyable and prosperous for all involved.

**INSTRUMENTATION TUBE FITTINGS – Tylok Standard
4 Seal, CBC-Lok™, CS-Lok™ • PIPE FITTINGS •
WELD FITTINGS • BALL VALVES – Ty-Flo® Standard &
Ty-Flo® 3 Piece • NEEDLE VALVES • INSTRUMENTATION
MANIFOLDS • FLEXIBLE METAL HOSE •**

TYLOK INTERNATIONAL, INC.

1061 East 260th Street • Euclid, Ohio 44132

Tel: (216) 261-7310 • 1-800-321-0466 • Fax: (216) 261-7317

info@tylok.com

www.tylok.com