



Positioners

K10 Electro-Pneumatic Positioner

- ▶ [K10](#) Electro-Pneumatic Positioner w/ Keypad & Remote Infrared AutoCal Calibration

ICoT Smart Positioners

- ▶ [Design Features](#)
- ▶ [ICoT 4100](#) Electro-Pneumatic Positioner
- ▶ [ICoT 4200](#) Intelligent Positioner with Keypad
- ▶ [ICoT 4300](#) Intelligent Positioner with Hart Capability

POSITIONERS

K 10

Electro-Pneumatic Positioner with Keypad & Remote Infrared AutoCal Calibration

The model K10 electro-pneumatic positioner is the first of its kind having calibration either by a simple AutoCal push of a button or remotely by implementing an infrared signal from a handheld. The K10 positioner brings a new level of efficiency to operating personnel responsible for the calibration of I/P positioners.



FEATURES

- Fast calibration through a simple pushbutton AutoCal procedure or remote calibration by utilizing an infrared handheld.
- Certified General Purpose, Nonincendive or Explosionproof or Intrinsically Safe.
- 2 year warranty.
- Beacon visual position monitor.
- Integrated position sensor capability.
- Corrosion resistant engineered resin Nema 4, 4x enclosure standard. (Explosionproof unit: Aluminum)
- Optional high flow transducer.

WESTLOCK

K10

Certification

FM Approved
CSA Certified



Nema 4, 4x
Nonincendive:
Class I, Groups A, B, C & D
Class II, Groups F & G,
Division 2

Intrinsically Safe:
Class I, II, III
Groups A - G; Division 1
(must be used with an
approved barrier)

Explosionproof:
Class I, Groups C & D
Class II, Groups E, F & G
Divisions 1 & 2

Dimensions (inches)

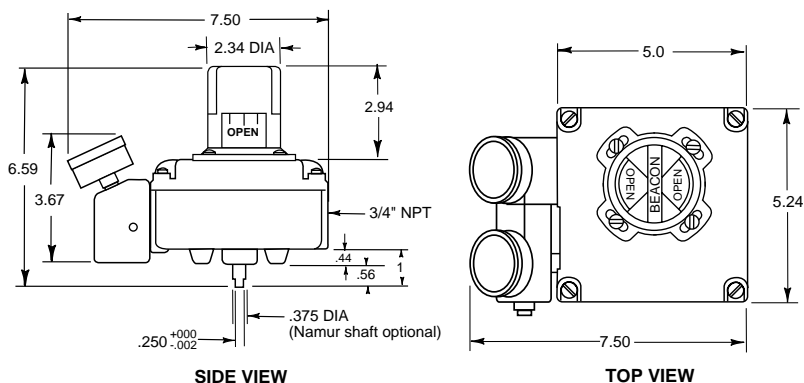

Materials of Construction (N/I & I/S)

Housing	Engineered Resin
Cover	Clear Engineered Resin
Manifold	Anodized Aluminum
Conduit	Stainless 3/4" NPT
Shaft	Stainless Steel
Hardware	Stainless Steel

Materials of Construction (Explosionproof)

Housing	Aluminum
Cover	Aluminum
Manifold	Aluminum (anodized)
Conduit	3/4" NPT
Shaft	Stainless Steel
Hardware	Stainless Steel

Micro-Switch V3

SPDT (V3)		
AMPS	VAC	VDC
15	125	
15	250	
10		24
0.50		125
0.25		125

Operating Specifications

Input current	4 to 20 mA (analog)
Voltage drop	9 volts
Supply air pressure	(low) 15 to 45 psi, (high) 40 to 120 psi
Resolution	0.2% of span
Linearity	±1% of span
Hysteresis	0.2% of span
Repeatability	0.2% of span
Thermal coefficient	2%/100°C
Output flow rates	(low) 8.0 scfm @ 25 psi, (high) 16.2 scfm @ 90 psi
Air consumption	(low) .30 scfm @ 25 psi, (high) .71 scfm @ 90 psi
Gain	Electronically adjustable
Air Connection Ports	1/4" NPT

P+F NJ2-V3 Sensors Proximity Type (Solid State), I.S., PTB, FM, CSA, CE

Sensing Range	3 mm
Electrical Version	D.C. voltage 2 wire in accordance with DIN19234 (NAMUR)
Hysteresis	Approx. 5%
Switching Frequency	1.5KHz
Nominal Voltage	8 VDC
Input Voltage Range	5-25 VDC
Output/Current	Cam Trigger Present ≤1mA
Consumption	Cam Trigger Absent ≥3mA (15mA max)
Operating Temp.	-25°C + 100°C

ORDERING GUIDE

K10	Area Classification	Cover (nonincendive)	Mounting	Supply Pressure	Manifold	Position Sensor
 K10 	Nema 4, 4x Nonincendive Class I, Grps. A, B, C & D Class II, Grps. F & G; Div. 2 N	Screws A	Standard S	High Pressure (40 to 120 PSI) H	Aluminum 0	No Switches O
	Intrinsically Safe Class I, II, III; Grps. A - G, Div.1 (must be used with an approved barrier) I		Namur N	Low Pressure (15 to 45 PSI) L	303 Stainless 3	1 Mech. Switch A
	Explosionproof Class I, Grps. C & D; Class II, Grps. E, F, G; Div. 1 & 2 X				316 Stainless 6	2 Mech. Switches B
						1 Inductive Proximity Sensor C
						2 Inductive Proximity Sensor D
						4-20 mA Position Transmitter E
Infrared Handheld for K10 Positioner						K10HH

Proximity Positioner

UNLIKE CONVENTIONAL POSITIONERS, THE ICoT POSITIONER FEEDS BACK VALVE POSITION WITHOUT THE NEED FOR LINKAGES OR LEVERS.

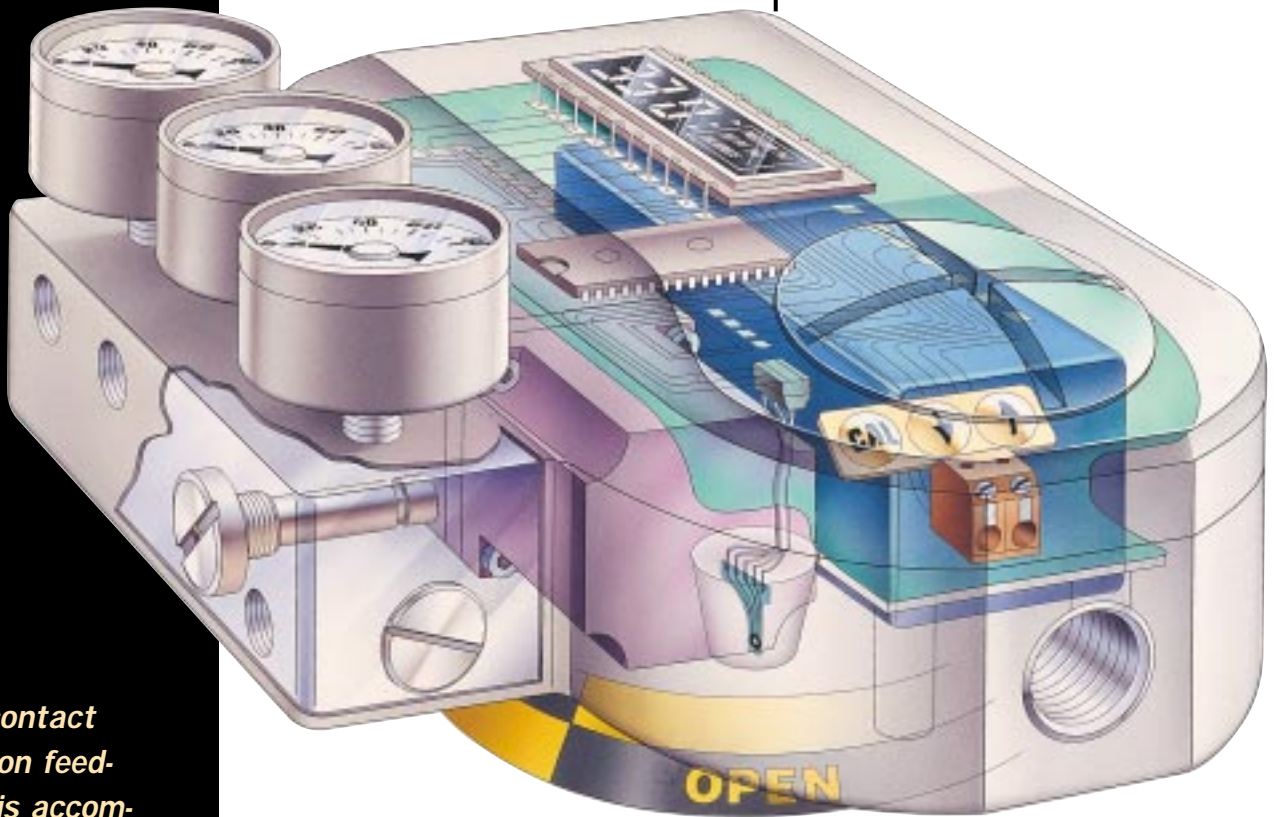

▶ **Non-contact position feedback is accomplished through the use of a proximity type solid state sensor**

Non-Contact Position Feedback

Unlike conventional positioners, the ICoT® (patent pending) feeds back accurate valve position without the need for linkages, levers, and rotary or linear seals. Position sensing is performed totally by non-contacting means, permitting use of advanced control strategies where knowledge of valve position is used in predictive and other algorithms.

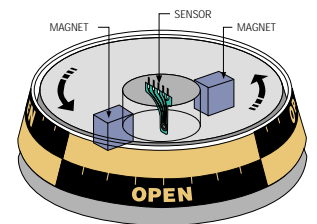

The Advantages of Non-Contact Position Feedback

Integrated Position Transmitter

The ICoT® is available with an integrated 4-20 mA position feedback transmitter. This cost effective feature eliminates the requirement for the purchase of externally mounted devices when knowledge of valve position is required at a remote location

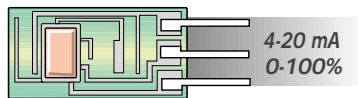

Intelligent Calibration, Local Keypad

ICoT® intelligent positioners are equipped with a HART® interface or a 3-button "membrane keypad" for performing on-site electronic calibration. The AutoCal feature allows for simple zero and span adjustments as well as PID and transducer calibration.

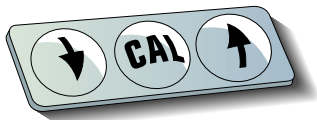

HART® Protocol

The ICoT® positioner responds to HART® commands for ease of calibration and provides intelligence for the control valve through a microprocessor based diagnostic system utilizing the HART® protocol. Accurate measurement of valve stem position, input signal, and actuator pressure offer operating personnel a real-time perspective on the state of control at the valve.



Remote Mount Capability

Since valve position feedback to the ICoT® positioner is accomplished by non-contacting means, the ICoT has the unique ability to be mounted remotely (up to a distance of 50 feet) from the device it is controlling. In the event the control valve is located in either a high vibration or extremely corrosive environment, the non-contact position feedback feature allows for isolated placement of the positioner.

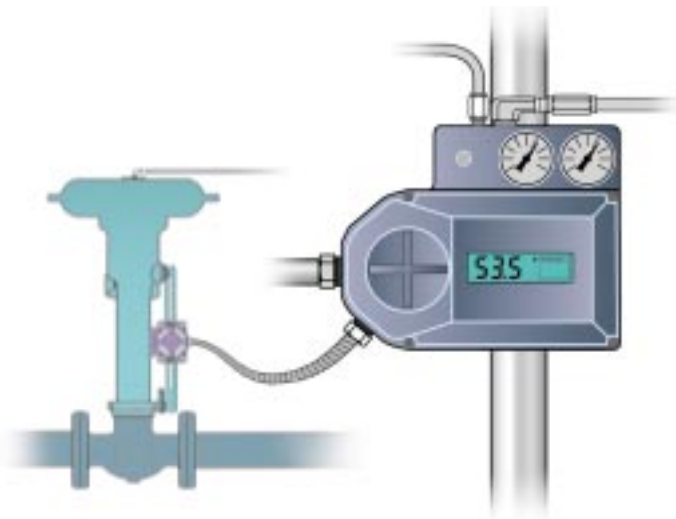

System Overview

- A** A microprocessor, housed within an environmentally sealed canister, performs position sensor linearization, AutoCal, characterization for valve type, PID control, autotuning, HART® information processing, and display management.
- B** An electropneumatic transducer, with internal diagnostic elements, converts the servo output signal into a pneumatic signal for directly driving valve actuators.
- C** Position feedback is accomplished by a non-contact Hall effect magnetic sensor. All rotary positioners are standardly equipped with a Beacon® position monitor.
- D** Air lines are connected to a machined aluminum manifold having gauges, filters, and a self-contained mechanism for cleaning the transducer orifice.
- E** For positioners not equipped with a HART® interface, a 3-button "membrane keypad" is provided for performing on-site electronic calibration.
- F** A standard hand-held terminal (the HART® Communicator) may be utilized for field operations in conjunction with a remote PC for maintenance information and documentation.
- G** A 32/64 channel HART® multiplexer provides diagnostic interfacing for multiple positioners.

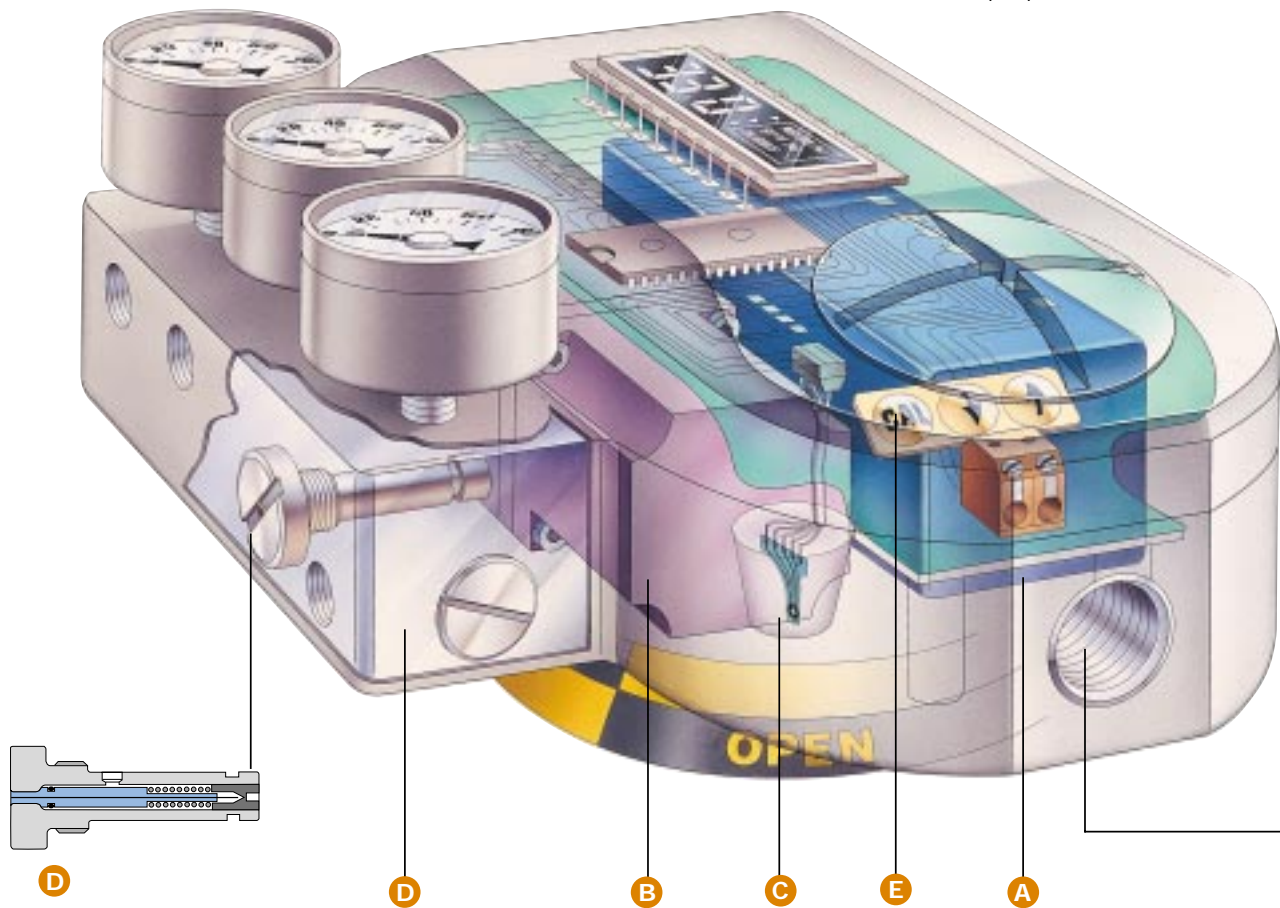

OPTIONS AND ACCESSORIES

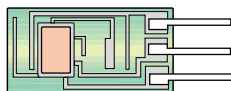

4-20 mA Position Transmitter



Proximity Position Sensors



Solenoid Valves

System Overview

DIAGNOSTICS

Plant operating personnel are given a real-time perspective on the state of control at the valve, including a view into operating integrity and emerging alarm conditions. Early-warning diagnostic information is constantly being updated to assist production scheduling and maintenance personnel.

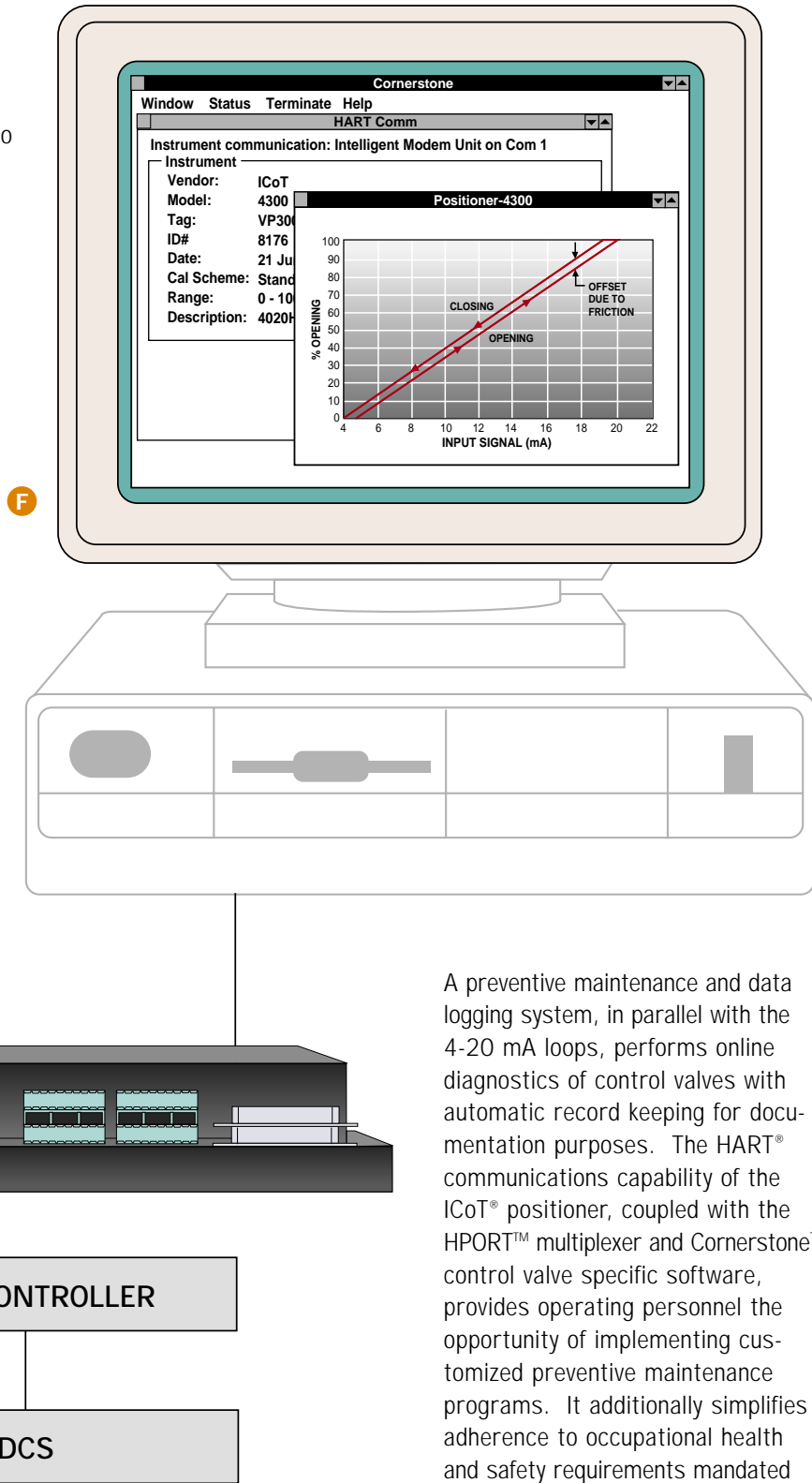

A preventive maintenance and data logging system, in parallel with the 4-20 mA loops, performs online diagnostics of control valves with automatic record keeping for documentation purposes. The HART® communications capability of the ICoT® positioner, coupled with the HPORT™ multiplexer and Cornerstone™ control valve specific software, provides operating personnel the opportunity of implementing customized preventive maintenance programs. It additionally simplifies adherence to occupational health and safety requirements mandated by government regulations.

HPORT is a trademark of ARCOM Control Systems, Inc.
CORNERSTONE is a trademark of Applied System Technologies, Inc.

Non-Contact Position Feedback



ROTARY CONTROL

Since valve position sensing is performed totally by proximity means, hysteresis within the positioner is non-existent. This feature allows for extremely accurate tracking of the control signal to within 1/10 of 1 mA. A non-contact position sensor, employing Hall Effect magnetic principles for position feedback, is embedded within the ICoT housing. An external magnetic module, attached to the output shaft of the actuator rotates about the Hall Effect sensor. An analog-to-digital converter interfaces between the position sensor and a microprocessor while also transmitting the incoming position command (instrument signal) to the microprocessor. Servo circuitry is then utilized for implementation of position control.

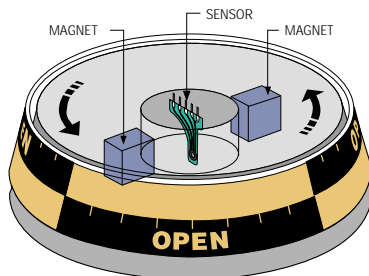

LINEAR CONTROL

The ICoT proximity positioner represents a significant departure from previous attempts to reliably measure valve stem position. A static slide-by actuation assembly, attached to the valve stem, is the only "moving part" of the positioner. Position sensing is performed totally by non-contacting means. Output updating takes place twenty times per second. A microprocessor implements any alteration required to provide the equivalent of equal percentage, quick opening, or linear valve characteristics.

Output of the processor is the "setpoint" input for the servo amplifier circuitry, while the position sensor provides feedback. The position sensor output signal is also fed to the analog-to-digital converter permitting a wide range of diagnostic information to be generated.

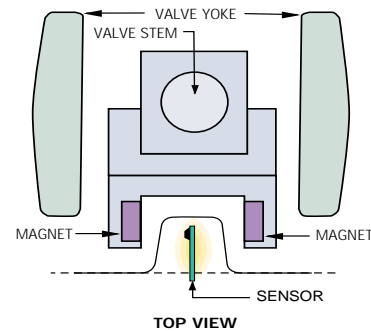

ICoT®

Remote Mount Capability

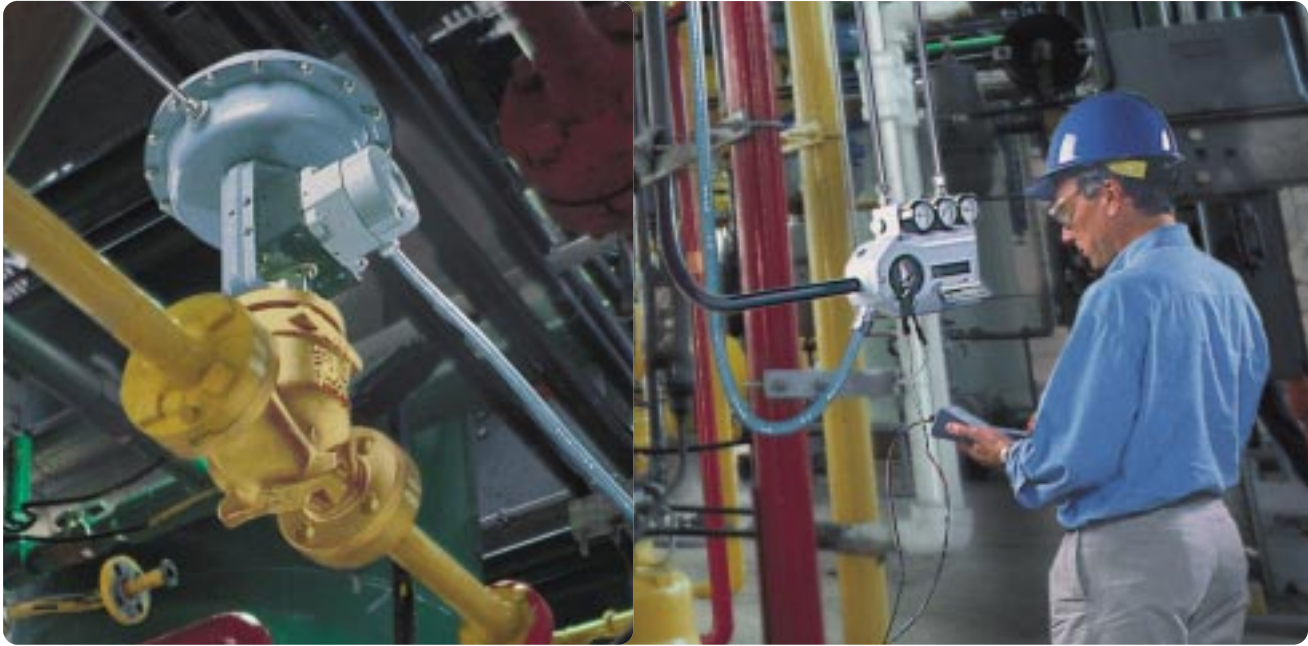

REMOTE POSITION CONTROL

The ICoT® is the only positioner capable of remotely controlling a process valve from up to a distance of fifty feet. Since valve position feedback is accomplished by non-contacting means, the ICoT proximity positioner has the unique ability to be mounted remotely from the device it is controlling. For applications where a control valve is located in either a high vibration or extremely corrosive environment, the non-contact position feedback feature allows for isolated placement of the positioner. The position sensor output signal is also fed to the analog-to-digital converter

housed within the positioner, thereby permitting a wide range of diagnostic information to be generated. From this information, conditions relating to excessive valve friction and the like, may be delineated. HART® information consisting of calibration data, current position, and various internal error conditions may be quickly retrieved due to the accessibility of the positioner.

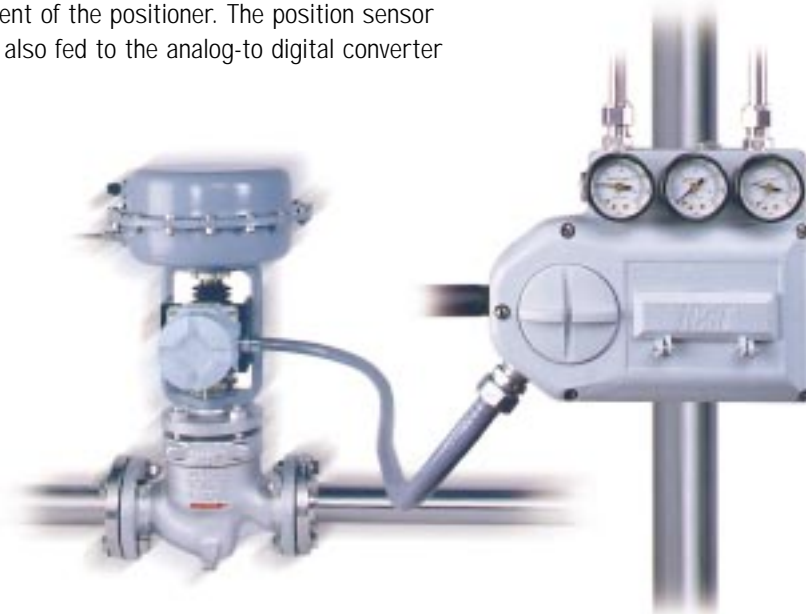

Dimensional Data

SERIES 4000 - Engineered Resin Enclosure (Dim. inches/mm)

Enclosure: Nema 4, 4X
Terminal Block: 8 Point Standard

Conduit Entrance: One 1/2" NPT Standard
1-1/2" & 2-3/4" NPT,

Optional
M20 or PG13.5 Optional

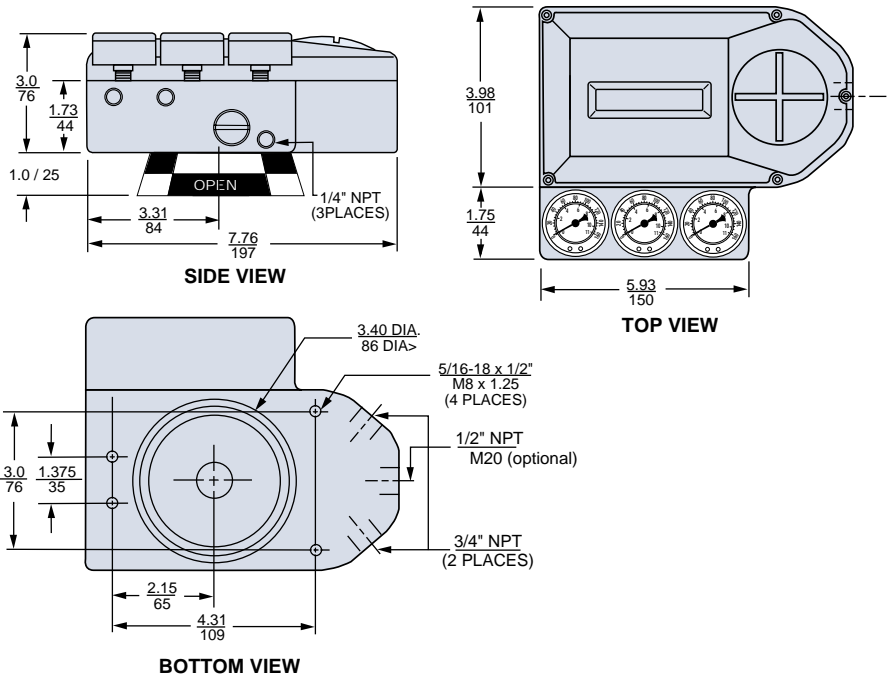

Westlock reserves the right to change product designs and specifications without notice, and is not responsible for errors and omissions.

Ordering Guide

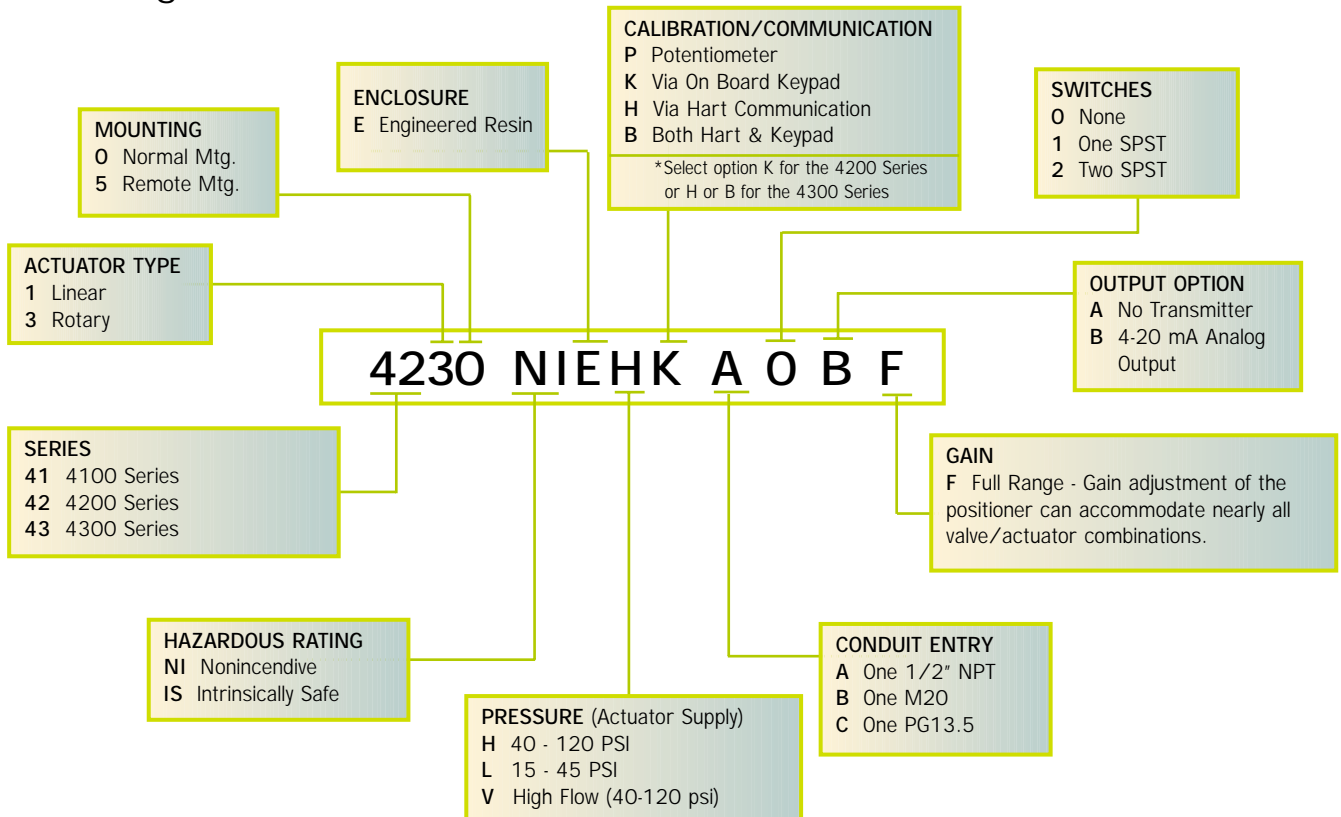

ICoT® 4100

Electro-Pneumatic Positioner



Proximity Positioner with Integrated Position Transmitter

After more than half a century the basic concept of the positioner has not changed much. However, once in a great while, fundamental thinking gets a push forward. The ICoT® 4100 represents one of those rare times. By creating the industry's first electro-pneumatic proximity positioner, the problems associated with conventional positioners requiring linkages or levers for position feedback is totally eliminated. Additionally, the Series 4100 has been engineered with ease of maintenance as a primary design consideration. Having only two major components (a transducer and electronic module) field personnel can simply replace either modular component for immediate restart of operations. An easily accessible

local analog display compares actual position to input signal and, as standard, a built-in position transmitter is integrated within the unit.

Integrated Position Transmitter

The ICoT 4100 is standardly equipped with an integrated 4-20 mA position feedback transmitter. As opposed to conventional devices, position sensing is performed by non-contacting means, based upon characterization of flux strength as a function of axial position.

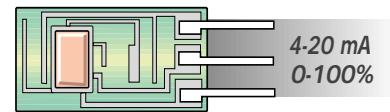



Remote Mount Capability

Since valve position feedback to the ICoT® positioner is accomplished by non-contacting means, the ICoT has the unique ability to be mounted remotely (up to a distance of 50 feet) from the device it is controlling. In the event the control valve is located in an

inaccessible location or a high vibration or extremely corrosive environment, the non-contact position feedback feature allows for isolated placement of the positioner.







Electro-Pneumatic Positioner

AGENCY APPROVALS	
	Nonincendive: Groups A - G Division 2
	Groups A - G Division 2

OPERATING SPECIFICATIONS

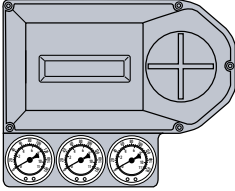
MODEL 4100	LINEAR	ROTARY
Input Current	4 to 20 mA (Analog)	
Voltage Drop	12.3 Volts	
Supply Air Pressure	(low) 15 to 45 PSI (high) 40 to 120 PSI	
Standard Stroke	.25 to 48 inches	0 to 95 Degrees
Resolution	0.2% of span	
Linearity	±1% of span	
Hysteresis	0.2% of span	
Repeatability	0.2% of span	
Thermal Coefficient	2% / 100°C	
Output Flow Rates	(low) 8.0 scfm @ 25 PSI (high) 16.2 scfm @ 90 PSI	
Air Consumption	(low) .30 scfm @ 25 PSI (high) .71 scfm @ 90 PSI	
Operating Temp. Range	-40°C to 85°C (-40°F to 185°F)	
Gain	Electronically Adjustable	
Feedback	Magnetic (Non-contact)	
Diagnostics	Analog Display	
Air Connection Ports	1/4" NPT	
Calibration Method	Potentiometers w/ calibration meter	

ORDERING GUIDE

ICoT® 4100	MOUNTING CONFIGURATION	CONSTRUCTION	PRESSURE/CALIBRATION	CONDUIT ENTRY	POSITION SENSOR	POSITION TRANSMITTER
<p>41</p>  <p>Nema 4, 4X Nonincendive Groups A - G, Division 2</p>   	STANDARD	Engineered Resin E	High Pressure (40 to 120 PSI) HP Low Pressure (15 to 45 PSI) LP High Flow (40-120 PSI) VP	1/2" NPT A M20 B	(Rotary Only)	4-20 mA (Standard Equipment)
	LINEAR Nonincendive 10NI				No Sensors 0	
	ROTARY Nonincendive 30NI				Magnum One SPST 1	
	REMOTE MOUNT				Magnum Two SPST 2	
LINEAR Nonincendive 15NI	Position switches not available on remote mount					
ROTARY Nonincendive 35NI						

4-20 mA position transmitter standard on model 4100

ICoT® 4200

Intelligent Positioner with Keypad



Intelligent Proximity Positioner with Keypad Calibration and On-Board Sensors

AutoCal

The ICoT® 4200 is equipped with a 3-button keypad interface and a 4-digit, .5" tall LCD that allows for automated calibration of the positioner.

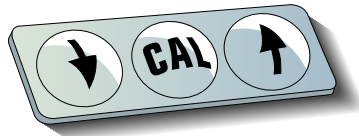

System calibration is performed easily requiring only minutes to accomplish. During the calibration process, the microprocessor measures position sensor voltage along with input setpoint current and establishes the amount of control signal required to move the valve to its end limits.

An on-board microprocessor uses the calibration data to provide accurate operation over the full span of valve travel during normal operation. The actual valve position measured and the amount of control signal applied at any time is a result of microprocessor interpolation. The interpolation method is operator selectable and can be Linear, Quick Opening, or Equal Percentage.

Split range and reverse acting operation are easily configured.



Local LCD Display

The local LCD display provides a multitude of onsite diagnostic information. While the valve is being controlled by the positioner, and the error signal is NOT zero, the displayed information will alternate between setpoint and position as percentage. Each value is displayed for a period of two seconds. Once the setpoint and valve position agree to within less than $\pm 0.5\%$, the display will only show position.

The range of values displayed are from 0.0% (fully closed) to 100% (fully open). Displayed resolution is in 0.1% increments, however, internal calculations are maintained at higher precision.

Integrated Position Transmitter

The ICoT 4200 is optionally available with an integrated 4-20 mA position feedback transmitter. As opposed to conventional devices, position sensing is performed by non-contacting means, based upon characterization of flux strength as a function of axial position.

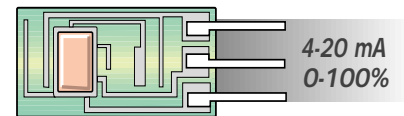

ICoT® 4200

Intelligent Positioner w/ Keypad

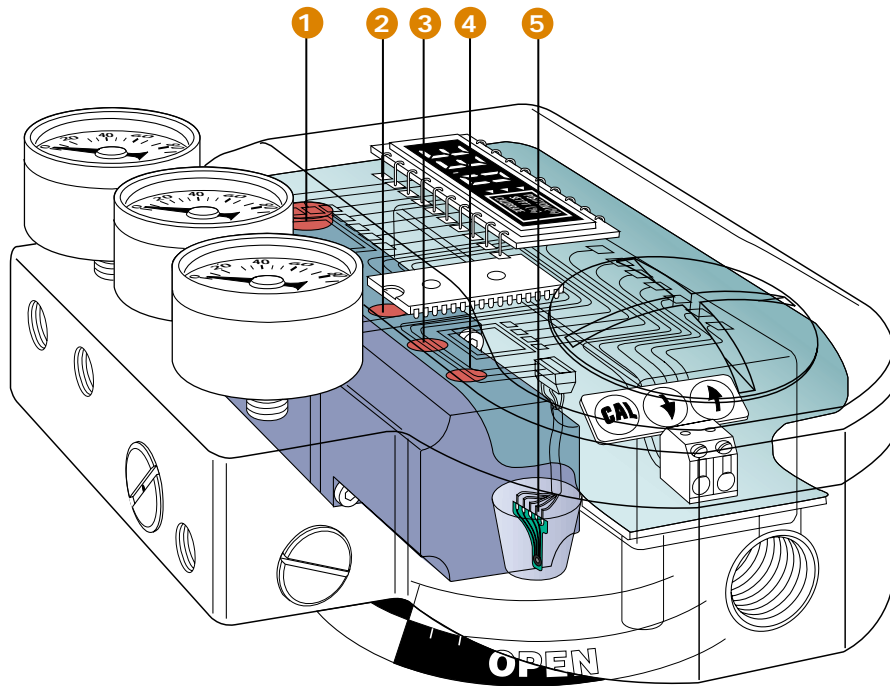

On-Board Sensors

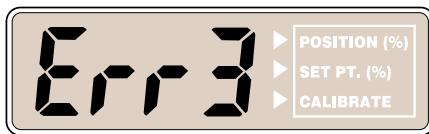

The ICoT® positioner has the capability to constantly monitor its own operation. If an error or failure condition occurs, it will be displayed on the local LCD or if the positioner is supplied with a HART® interface, the error codes will be displayed on a hand-held terminal or PC maintenance station. The following codes are provided:

- Err1 = Clogged nozzle or change filter
- Err3 = Low input pressure or clogged filter
- Err6 = Calibration error

The above alarm conditions and additional diagnostic capabilities are provided through a number of sensor elements in the transducer which are capable of indicating problematic operation.

Remote Mount Capability

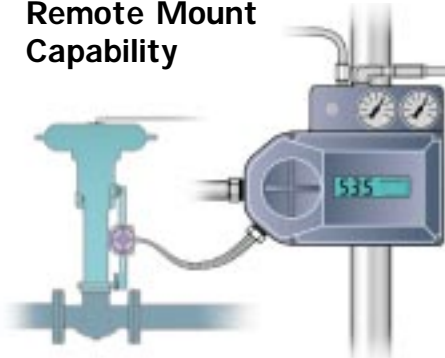

Since valve position feedback to the ICoT positioner is accomplished by non-contacting means, the ICoT has the unique ability to be mounted remotely (up to a distance of 50 feet) from the device it is controlling. In the event the control valve is located in either a high vibration or extremely corrosive environment, the non-contact position feedback feature allows for isolated placement of the positioner.

1 A pressure transducer compares actuator output pressure to the incoming transducer signal for diagnostic purposes. These two parameters are graphically displayed via the HART® interface and provide valuable data. For example, the relationship between actuator pressure and valve travel allows for stem friction, spring rate, and benchset parameters to be calculated. Excessive stem friction may imply the presence of packing or guide bushing problems. Additionally, detection of a non-operational spool valve within the ICoT® positioner is also made possible by the pressure sensor whose output is utilized for comparison with the servo output command to the transducer.

2 A pressure switch detects abnormal internal pressure within the transducer indicative of a restricted nozzle or punctured diaphragm.

3 A pressure switch detects low air pressure entering the positioner. In conjunction with a supply pressure switch, a determination can be made that either a restricted filter is responsible for low air pressure entering the positioner or a bonafide low supply pressure conditions exists.

4 Low air supply pressure is detected by a pressure switch upstream of the internal filter and provides warning of insufficient power for valve stroking.

5 A 0-100% position feedback transmitter is available integrated within the electronics of the ICoT positioner.

Intelligent Positioner w/ Keypad

PID Control

A positioner is a servo system that continuously controls the position (output) of a valve in accordance with an external control signal referred to as setpoint. In a proportional type system, the setpoint is constantly being subtracted from the output (position). This signal, resulting from the constant subtraction, is termed as error (setpoint - output = error) which multiplied by a constant is used to modify the final output. The magnitude of this product is termed proportional gain or "P" (error x constant = P).

It would seem that the greater one makes "P" the less the error would appear in the final output. Unfortunately, in practice, this does not hold true.

Graph #1 displays the response of a positioner to a sudden change of setpoint for different values of "P". Setting a small value to "P" results in a final output which differs from the desired output by a large error (curve A). Setting a large value to "P" results in an uncontrollable continuous oscillation of output termed "Ultimate P" (curve C). By interpolating different values of "P", a value may be obtained which produces a medium error having a stable response (curve B). However, the result of a proportional only type system still results in a relatively large error and slow speed of response.

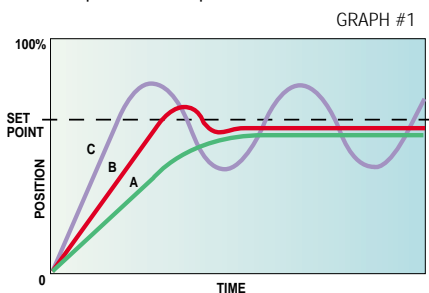

The ICoT smart positioner greatly enhances the performance of the proportional only type system. A derivative ("D") is added to the servo of the ICoT. "D" is the derivative of the output with respect to time or the speed at which the valve position moves multiplied by a constant (speed x constant = "D"). The positioner is now converted into a "PD" servo type system. The addition of "D" into the system increases speed of response while decreasing overshoot. It also allows for "P" to increase above the ultimate proportional value, thereby reducing the final error (see graph #2).

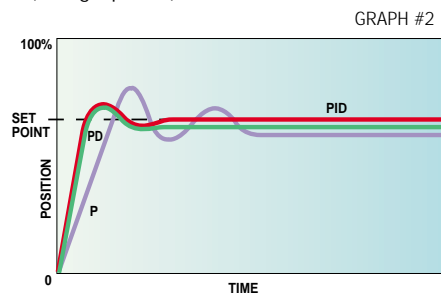

In order to decrease the error even further, a third function, "I", is added to the "PD" servo. The integrator ("I") slowly decreases the error when the position reaches stability. This addition of the "I" function converts the ICoT into a "PID" servo type system.





Autotuning

The setting of the proportional, integral, and derivative functions ("PID"), also referred to as "tuning" can become quite complex and tedious. By utilizing the microcontroller within the ICoT, Westlock has designed an algorithm which automatically tunes all three parameters. This procedure is referred to as "autotuning".

Upon receiving a request for autotune, the positioner enters into a digital mode and overrides any setpoint command. It initiates the routine by setting "P", "I", and "D" at their lowest values. It will then begin to increase the "P" value until it reaches "Ultimate P". At this instance the CPU records "Ultimate P" and the coinciding period of oscillation. With the recorded data in memory, the CPU then performs a modified Ziegler-Nichols analysis and correspondingly assigns correct values to the "P", "I", and "D" functions.





Intelligent Positioner w/ Keypad

AGENCY APPROVALS	
	Nonincendive: Groups A - G, Division 2 Intrinsically Safe: Groups A - G, Divisions 1 & 2
	Groups A - G, Division 2 Intrinsically Safe: Groups A - G, Divisions 1 & 2
	EEx ib IIC T4

OPERATING SPECIFICATIONS

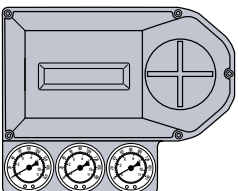
MODEL 4200	LINEAR	ROTARY
Input Current	4 to 20 mA (Analog)	4 mA (Digital HART)
Voltage Drop	12.3 Volts	
Supply Air Pressure	(low) 15 to 45 PSI (high) 40 to 120 PSI	
Standard Stroke	.25 to 48 inches	0 to 95 Degrees
Resolution	0.2% of span	
Linearity	1% of span	0.5% of span
Hysteresis	0.2% of span	
Repeatability	0.2% of span	
Thermal Coefficient	2% / 100°C	
Output Flow Rates	(low) 8.0 scfm @ 25 PSI (high) 16.2 scfm @ 90 PSI	
Air Consumption	(low) .30 scfm @ 25 PSI (high) .71 scfm @ 90 PSI	
Operating Temp. Range	-40°C to 85°C (-40°F to 185°F)	
Gain	Electronically Adjustable w/ Autotuning	
Speed Response	Electronically Adjustable	
Feedback	Magnetic (Non-contact)	
Diagnostics	LCD Display	
Air Connection Ports	1/4" NPT	
Calibration Method	Electronic Keypad	

ORDERING GUIDE

ICoT® 4200	MOUNTING CONFIGURATION	CONSTRUCTION	PRESSURE/CALIBRATION	CONDUIT ENTRY	POSITION SENSOR	POSITION TRANSMITTER		
42  Nema 4, 4X Nonincendive Groups A - G, Division 2 Intrinsically Safe Groups A - G, Divisions 1 & 2   	STANDARD	Engineered Resin E	High Pressure (40 to 120 PSI) HK Low Pressure (15 to 45 PSI) LK High Flow (40-120 PSI) VK	1/2" NPT A M20 B	(Rotary Only)	Without Transmitter A 4-20 mA B		
	LINEAR Nonincendive 10NI Intrinsically Safe 10IS				ROTARY Nonincendive 30NI Intrinsically Safe 30IS		O	1
	REMOTE MOUNT				LINEAR Nonincendive 15NI Intrinsically Safe 15IS		2	Position switches not available on remote mount
	ROTARY Nonincendive 35NI Intrinsically Safe 35IS							



Intelligent Proximity Positioner with HART® Communicator Capability and Online Diagnostics

ICoT® 4300

Intelligent Positioner w/ Hart® Capability

Intelligent Calibration HART® Protocol

The ICoT® 4300 provides intelligence for the control valve through a microprocessor-based system utilizing the HART® protocol. Accurate measurement of valve stem position, input signal, and actuator pressure can be recorded during normal operation, thereby providing information for control valve signature generation.

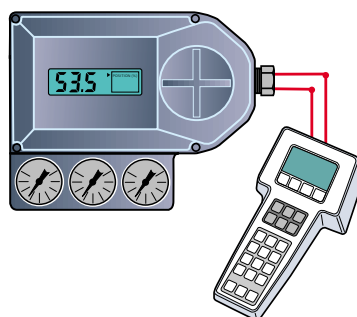

A standard hand-held terminal (the HART® Communicator) may be utilized for field operations in conjunction with a remote PC for maintenance information and documentation.

Intelligent Control

ICoT, with HART® protocol, opens up an endless array of new possibilities for improving efficiency and preventive maintenance procedures in all areas pertaining to control valve usage.

ICoT® 4300

Local LCD Display
Local Position Display
Local Diagnostics

Auto Cal, PID Control
Autotuning

Keypad Calibration
Hand-Held Communicator

Online Diagnostics
Fugitive Emissions Monitoring
End Limit Position Sensing

4-20 mA Position Transmitter
Early-Warning Diagnostic
Software
Multiplex Capability

Remote Position Control

Diagnostic Capability

A preventive maintenance and data logging system, in parallel with the 4-20 mA loops, performs online diagnostics of control valves with automatic record keeping for documentation purposes. The HART® communications capability of the ICoT® positioner, coupled with the HPORT™ multiplexer and Cornerstone™ control valve specific software, provides operating personnel the opportunity of implementing customized preventive maintenance programs. It additionally simplifies adherence to occupational health and safety requirements mandated by government regulations.

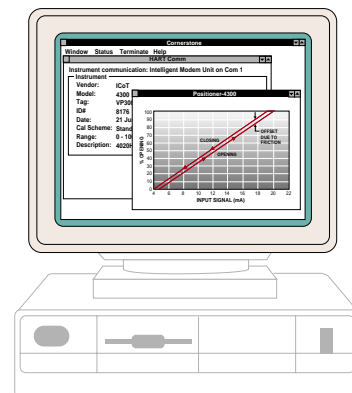

HPORT is a trademark of ARCOM Control Systems, Inc.
CORNERSTONE is a trademark of Applied System Technologies, Inc.

ICoT® 4300

Intelligent Positioner w/ Hart® Capability



HART® Hand-Held Terminal

A single 4-20 mA ICoT® positioner with up to two master devices may be connected to each HART® loop. The primary master is generally a management system or a PC while the secondary unit can be a hand-held terminal or laptop computer.

A standard hand-held HART® Communicator is available for making field operations as uniform as possible. Manufactured by Rosemount, the Model 275 Smart Family® Interface functions

as a common tool for HART® micro-processor-based field instruments. From any wiring termination point in the loop, the battery-powered Model 275 can perform diagnostic, configuration, and interrogation functions. Additionally, while the 275 is offline, configuration data can be stored for later downloading to one or more positioners. Simultaneous communication capabilities allow the hand-held terminal to receive data from and send data to the positioner without disrupting the positioner's signal from the control room.

Communication

The Model 275 communicates with ICoT® Smart Positioners via HART® protocol. Communication is accomplished by superimposing a high frequency signal on top of the 4-20 mA output signal. This allows simultaneous communication and output without comprising loop integrity.

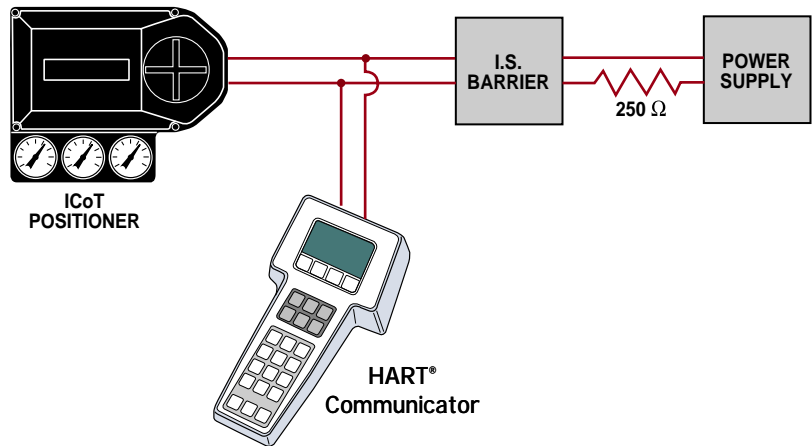

HAZARDOUS LOCATIONS CERTIFICATIONS

CENELEC/BASEEFA
Intrinsic Safety Certification
EEx ib IIC T6
Certificate No. Ex89C2279

Factory Mutual (FM)
Intrinsic Safety and Nonincendive Approval
Intrinsically Safe for Class I, Division 1, Groups A, B, C and D; Nonincendive for Class I, Division 2, Groups A, B, C and D.

Canadian Standards Association (CSA)
Intrinsic Safety Approval.
Intrinsically Safe for Class I, Division 1, Groups A, B, C and D.

SPECIFICATIONS

FUNCTIONAL SPECIFICATIONS	
Memory	A nonvolatile memory retains stored information when the Model 275 is powered down; provided a charged battery pack is installed.
Power Supply	Five AA 1.5V batteries. (Rechargeable nickel-cadmium battery pack optional.)
PERFORMANCE SPECIFICATIONS - Temperature Limits	
Operating Limits	32 to 122°F (0 to 50°C)
Storage Limits	-4 to 158°F (-20 to 70°C)
Humidity Limits	Operates in 0-95% relative humidity under non-condensing conditions below 104°F (40°C) without error.
PHYSICAL SPECIFICATIONS	
Display	4-line liquid crystal display with 20 character line width.
Keyboard	Complete alphanumeric keyboard, six dedicated function keys, and four software defined keys.
Weight	Approximately 2 lbs. (0.9 kg) including batteries.

Intelligent Positioner w/ Hart® Capability

Diagnostic and Configuration Software

ICoT® has developed a Smart Positioner possessing the capability to predict rather than react to valve maintenance needs. With the ICoT® positioner, operating personnel gain a real-time perspective on the state of control at the valve, including a view of operating integrity and emerging alert conditions. Timely information about each control valves condition is quickly made available to the plant's production and maintenance engineers.



THE PRINCIPLE ADVANTAGE OF ONLINE DIAGNOSTICS IS THE ABILITY TO DETECT DEVIATIONS FROM ESTABLISHED PATTERNS OF BEHAVIOR AS THEY OCCUR UNDER ACTUAL OPERATING CONDITIONS.

Control valves are the most maintenance intensive components commonly used in instrumentation and control systems. By inclusion of internal parameter sensing within the valve positioner, forewarning of the need for maintenance is made available with a comfortable degree of lead time.

The ICoT® positioner's diagnostic compatibility is based upon observations of the following operating parameters:

- Valve position vs. input signal.
- Actuator pressure vs. valve position.
- Airset filter outlet pressure.
- Confirmation of principal operating pressures within positioner.
- Pressure generation within packing gland area.

Online Diagnostics via HART® Link

- "Stick-slip" detection.
- Excessive static position error.
- Fugitive emissions monitoring.
- Low air supply pressure.
- Clogged air supply filter.
- Restricted transducer nozzle.
- Transducer diaphragm air leak.
- Non-functioning spool valve.
- Calibration error.

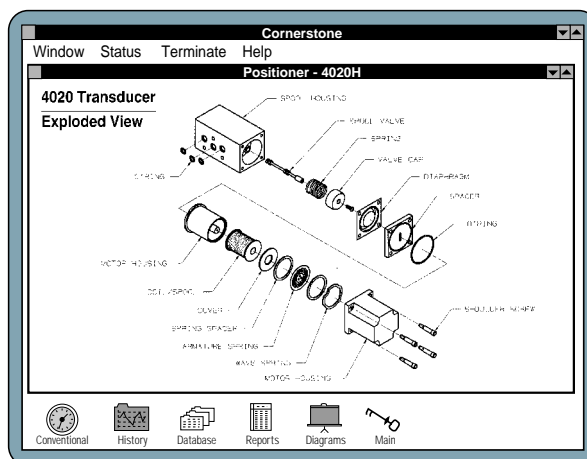

For additional information utilizing Hart compatible software such as Cornerstone or Fisher Rosemounts' AMS, please consult factory.



Cornerstone software

ICoT® 4300





Intelligent Positioner w/ Hart® Capability

AGENCY APPROVALS		
	Nonincendive: Groups A - G, Division 2	Intrinsically Safe: Groups A - G, Divisions 1 & 2
	Groups A - G, Division 2 Intrinsically Safe: Groups A - G, Divisions 1 & 2	
	EEx ib IIC T4	

OPERATING SPECIFICATIONS

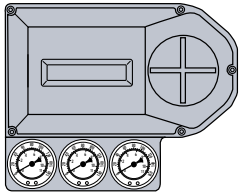
MODEL 4300	LINEAR	ROTARY
Input Current	4 to 20 mA (Analog) 4 mA (Digital HART)	
Voltage Drop	12.3 Volts	
Supply Air Pressure	(low) 15 to 45 PSI (high) 40 to 120 PSI	
Standard Stroke	.25 to 48 inches	0 to 95 Degrees
Resolution	0.2% of span	
Linearity	1% of span	0.5% of span
Hysteresis	0.2% of span	
Repeatability	0.2% of span	
Thermal Coefficient	2% / 100°C	
Output Flow Rates	(low) 8.0 scfm @ 25 PSI (high) 16.2 scfm @ 90 PSI	
Air Consumption	(low) .30 scfm @ 25 PSI (high) .71 scfm @ 90 PSI	
Operating Temp. Range	-40°C to 85°C (-40°F to 185°F)	
Gain	Electronically Adjustable w/ Autotuning	
Speed Response	Electronically Adjustable	
Feedback	Magnetic (Non-contact)	
Diagnostics	HART Protocol	
Air Connection Ports	1/4" NPT	
Calibration Method	HART® or HART® & Keypad	

ORDERING GUIDE

ICoT® 4300	MOUNTING CONFIGURATION	CONSTRUCTION	PRESSURE/ CALIBRATION	CONDUIT ENTRY	POSITION SENSOR	POSITION TRANSMITTER	
43  Nema 4, 4X Nonincendive Groups A - G, Division 2 Intrinsically Safe Groups A - G, Divisions 1 & 2   	STANDARD	Engineered Resin E	High Pressure (40 to 120 PSI) HART & Keypad HB HART Only HH <hr/> Low Pressure (15 to 45 PSI) HART & Keypad LB HART Only LH <hr/> High Flow (40-120 psi) Hart & Keypad VB Hart Only VH	1/2" NPT A M20 B	(Rotary Only)	Without Transmitter A 4-20 mA B	
	LINEAR Nonincendive 10NI Intrinsically Safe 10IS				ROTARY Nonincendive 30NI Intrinsically Safe 30IS		0 1 2
	REMOTE MOUNT				LINEAR Nonincendive 15NI Intrinsically Safe 15IS		Position switches not available on remote mount
	ROTARY Nonincendive 35NI Intrinsically Safe 35IS						