

# Clamp-On



## Description

Winters' Clamp-On Thermometers provide fast and accurate temperature readings of pipes with diameters between 1/2" (12.7mm) and 4" (100mm). The thermometers are attached to the pipe using a flexible steel spring which is included.

The Clamp-On Thermometers are the ideal instrument to "strap on" a pipe to determine the approximate media temperature within the pipe. Accuracy is +/- 3% full scale.

### Specifications

<b>Dial:</b>	2.5" (63mm) aluminum with black markings
<b>Case:</b>	Mild steel
<b>Lens:</b>	Plexiglass
<b>Ring:</b>	Steel, chrome plated
<b>Pointer:</b>	Aluminum, painted black
<b>Over-Range Protection:</b>	25% of full scale value
<b>Ambient Temperature:</b>	-40°F to 390°F (-40°C to 200°C)
<b>Process Temperature:</b>	-40°F to 390°F (-40°C to 200°C)
<b>Accuracy:</b>	± 3% full scale
<b>Protection:</b>	IP52

**How to order: Specify product code**

### PRODUCT CODES

Range	Code
-40/110° F & -40/40° C	T166
30/240° F & 0/115° C	T167
30/390° F & 0/200° C	T168

Other ranges available upon request.

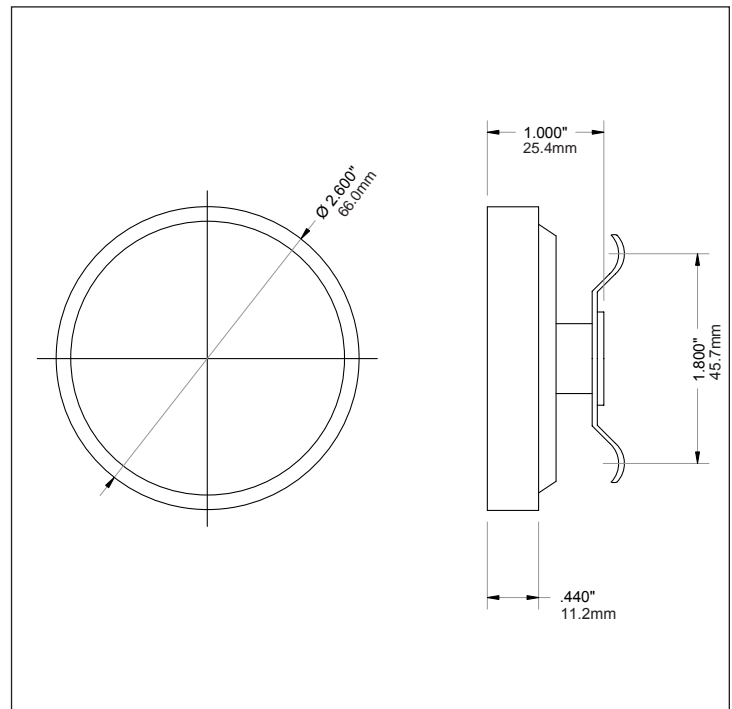

Corporate Office: 121 Railside Road • Toronto • ON • M3A 1B2 • (416) 444-2345 • Fax: (416) 444-8979

U.S.A. Office: 600 Ensminger Road • Buffalo • NY • 14150 • (716) 874-8700 • Fax: (716) 874-8800

[www.winters.com](http://www.winters.com) • 1-800-WINTERS (946-8377)

12/02