

# HVAC Thermometer (GC Series)

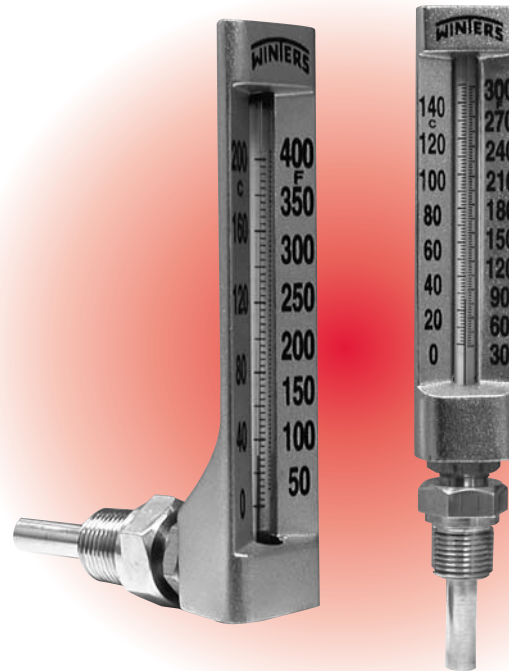

## Description

Winters HVAC (GC Series) Thermometer is used in heating, plumbing, air conditioning and ventilation (HVAC) applications. Winters gold-coloured aluminum case thermometers are available in 4 1/2" (110mm) or 6"(150mm) scales. The HVAC thermometer (GC Series) offers ruggedness and durability in harsh industrial environments. A brass socket 1/2" NPT is standard (stainless steel optional) and the thermometer is available in either a straight model (bottom connection) or 90° angle model (back connection).

## Specifications

<b>Case:</b>	4 1/2" (110 mm) or 6" (150 mm) aluminum, anodized gold
<b>Scale:</b>	Aluminum, black markings
<b>Tube:</b>	Glass cushioned
<b>Liquid Filling:</b>	Organic liquid (red)
<b>Stem:</b>	Brass standard, or stainless steel optional
<b>Connection:</b>	1/2" NPT (1/2" BSP optional)
<b>Swivel Nut:</b>	Brass standard, or stainless steel optional (swivel & stem one unit)
<b>Operating Pressure:</b>	Maximum 710 psi (50 kg/cm <sup>2</sup> )
<b>Ambient Temperature:</b>	-40F-400F (-40C-200C)
<b>Process Temperature:</b>	-40F-400F (-40C-200C)
<b>Operating Temperature:</b>	Maximum 80% of full scale value recommended
<b>Accuracy:</b>	± 2% of full scale
<b>Protection:</b>	IP65



Corporate Office: 121 Railside Road • Toronto • ON • M3A 1B2 • (416) 444-2345 • Fax: (416) 444-8979

U.S.A. Office: 600 Ensminger Road • Buffalo • NY • 14150 • (716) 874-8700 • Fax: (716) 874-8800

[www.winters.com](http://www.winters.com) • 1-800-WINTERS (946-8377)

# HVAC Thermometer (GC Series)

How to order: Specify product code

PRODUCT CODES				
RANGES	Straight		Angle	
	4 1/2" (110mm)	6" (150mm)	4 1/2" (110mm)	6" (150mm)
-40/110 F & -40/40 C	T130AG4	T130AG6	T140AG4	T140AG6
20/180 F & -5/80 C	T131AG4	T131AG6	T141AG4	T141AG6
30/240 F & 0/115 C	T132AG4	T132AG6	T150AG4	T150AG6
30/300 F & 0/150 C	T134AG4	T134AG6	T143AG4	T143AG6
50/400 F & 10/200 C	T133AG4	T133AG6	T142AG4	T142AG6

Options:

- 304 st/st thermowell available upon request
- Other ranges and connection sizes available

4.5" Straight

6" Angled

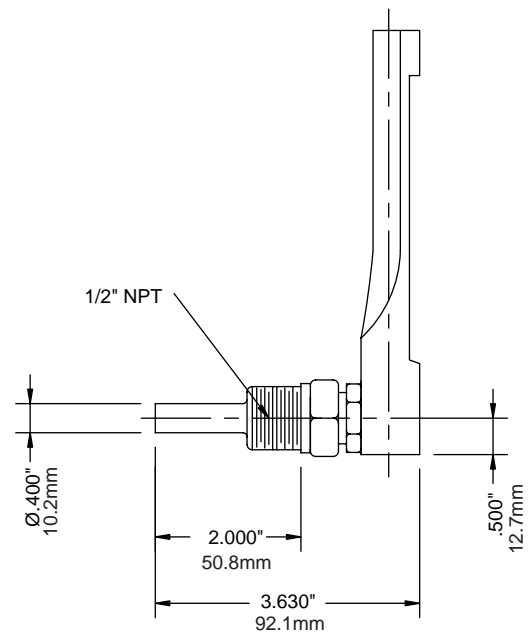
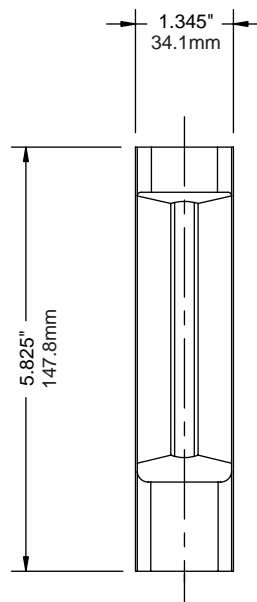
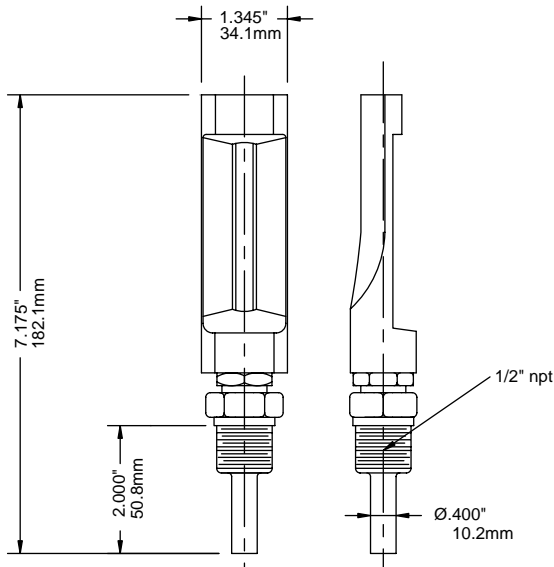

Corporate Office: 121 Railside Road • Toronto • ON • M3A 1B2 • (416) 444-2345 • Fax: (416) 444-8979

U.S.A. Office: 600 Ensminger Road • Buffalo • NY • 14150 • (716) 874-8700 • Fax: (716) 874-8800

[www.winters.com](http://www.winters.com) • 1-800-WINTERS (946-8377)