

Thermowells

FLANGED

New!

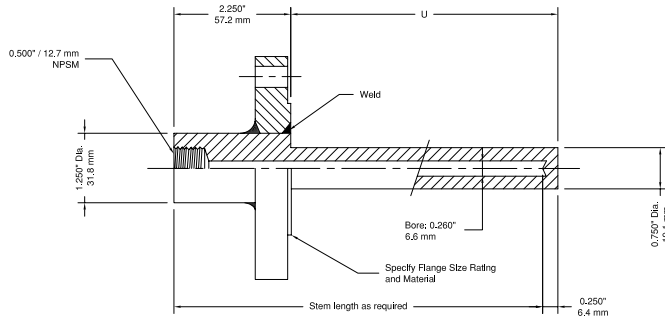

Features:

- 304 stainless steel or 316 stainless steel construction
- 1/2" NPSM thermometer connection
- 0.260" (6.604mm) bore standard (0.385 (9.779mm) bore available)

Applications:

Designed for use on a closed system. The flanged thermowell allows a closed system to easily be disassembled.

How to order: Specify product code

Element Length	"U" Dimension	Material	Product Codes		
			Flange Size and Rating		
			1", 150#	1.5", 150#	2", 150#
4" stem	2"	304 St/St.	TWF11504304	TWF151504304	TWF21504304
4" stem	2"	316 St/St.	TWF11504316	TWF151504316	TWF21504316
6" stem	4"	304 St/St.	TWF11506304	TWF151506304	TWF21506304
6" stem	4"	316 St/St.	TWF11506316	TWF151506316	TWF21506316
9" stem	7"	304 St/St.	TWF11509304	TWF151509304	TWF21509304
9" stem	7"	316 St/St.	TWF11509316	TWF151509316	TWF21509316
12" stem	10"	304 St/St.	TWF115012304	TWF1515012304	TWF215012304
12" stem	10"	316 St/St.	TWF115012316	TWF1515012316	TWF215012316
15" stem	13"	304 St/St.	TWF115015304	TWF1515015304	TWF215015304
15" stem	13"	316 St/St.	TWF115015316	TWF1515015316	TWF215015316

Element Length	"U" Dimension	Material	Flange Size and Rating		
			1", 300#		
			1", 300#	1.5", 300#	2", 300#
4" stem	2"	304 St/St.	TWF13004304	TWF153004304	TWF23004304
4" stem	2"	316 St/St.	TWF13004316	TWF153004316	TWF23004316
6" stem	4"	304 St/St.	TWF13006304	TWF153006304	TWF23006304
6" stem	4"	316 St/St.	TWF13006316	TWF153006316	TWF23006316
9" stem	7"	304 St/St.	TWF13009304	TWF153009304	TWF23009304
9" stem	7"	316 St/St.	TWF13009316	TWF153009316	TWF23009316
12" stem	10"	304 St/St.	TWF130012304	TWF1530012304	TWF230012304
12" stem	10"	316 St/St.	TWF130012316	TWF1530012316	TWF230012316
15" stem	13"	304 St/St.	TWF130015304	TWF1530015304	TWF230015304
15" stem	13"	316 St/St.	TWF130015316	TWF1530015316	TWF230015316

Other configurations available.

SANITARY

Features:

- 316 stainless steel
- 1.5" (40mm) or 2" (50mm) Tri-Clamp® connection
- 1/2" NPT thermometer connection
- Lengths to fit all standard bimetal thermometers

Applications:

Designed specifically for sanitary requirements of the food and dairy industry. Winters Sanitary Thermowells allow for easy installation and replacement of bimetallic dial thermometers without draining the process.

How to order: Specify product code

Stem Length	Code	Tri-Clamp® connection
2.5" (63mm)	15SANI2	1.5" (40mm)
4" (100mm)	15SANI4	1.5" (40mm)
6" (150mm)	15SANI6	1.5" (40mm)
9" (225mm)	15SANI9	1.5" (40mm)
Over 9"	15SANIX	1.5" (40mm)
2.5" (63mm)	2SANI2	2" (50mm)
4" (100mm)	2SANI4	2" (50mm)
6" (150mm)	2SANI6	2" (50mm)
9" (225mm)	2SANI9	2" (50mm)
Over 9"	2SANIX	2" (50mm)

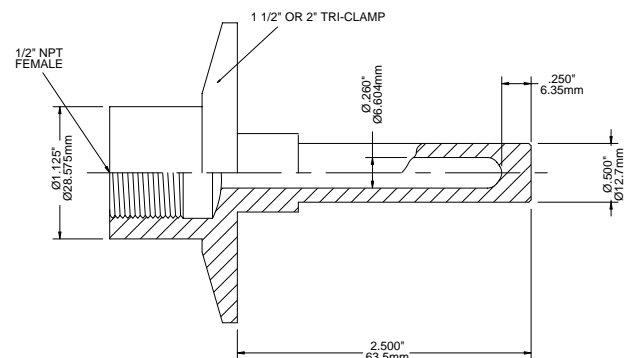

Corporate Office: 121 Railside Road • Toronto • ON • M3A 1B2 • (416) 444-2345 • Fax: (416) 444-8979

U.S.A. Office: 600 Ensminger Road • Buffalo • NY • 14150 • (716) 874-8700 • Fax: (716) 874-8800

www.winters.com • 1-800-WINTERS (946-8377)

Thermowells

SOCKET WELD

New!

How to order: Specify product code
PRODUCT CODES

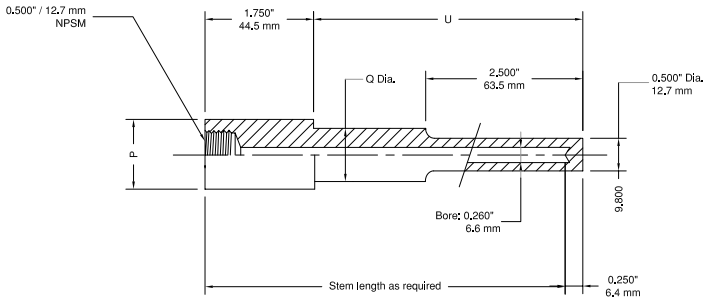

Features:

- 304 stainless steel or 316 stainless steel construction
- 1/2" NPSM thermometer connection
- 0.260" (6.604mm) bore
- Other configurations available

Applications:

Designed to be welded in place within the system. Common applications include: slow velocity applications, for example, a feed water system on a boiler.

Stem Length	"U" Dimension	Material	Code
3/4" Pipe Size			
4" (100mm)	2.5"	304 St/St.	TWSW754304
4" (100mm)	2.5"	316 St/St.	TWSW754316
6" (150mm)	4.5"	304 St/St.	TWSW756304
6" (150mm)	4.5"	316 St/St.	TWSW756316
9" (228.6mm)	7.5"	304 St/St.	TWSW759304
9" (228.6mm)	7.5"	316 St/St.	TWSW759316
12" (304.8mm)	10.5"	304 St/St.	TWSW7512304
12" (304.8mm)	10.5"	316 St/St.	TWSW7512316
1" Pipe Size			
4" (100mm)	2.5"	304 St/St.	TWSW14304
4" (100mm)	2.5"	316 St/St.	TWSW14316
6" (150mm)	4.5"	304 St/St.	TWSW16304
6" (150mm)	4.5"	316 St/St.	TWSW16316
9" (228.6mm)	7.5"	304 St/St.	TWSW19304
9" (228.6mm)	7.5"	316 St/St.	TWSW19316
12" (304.8mm)	10.5"	304 St/St.	TWSW112304
12" (304.8mm)	10.5"	316 St/St.	TWSW112316

TEST

New!

Features:

- 304 stainless steel or 316 stainless steel construction
- 1/2" NPSM thermometer connection
- 0.260" (6.604mm) bore
- Other dimensions available

Applications:

Utilized to provide a closed system, even when the process is not being tested. The thermowell allows a place to test the system at random with a portable instrument without opening or shutting down the process. When the thermowell is not being used, a cap and chain keep the dirt, dust, etc out of the thermowell.

To order, please contact Winters.

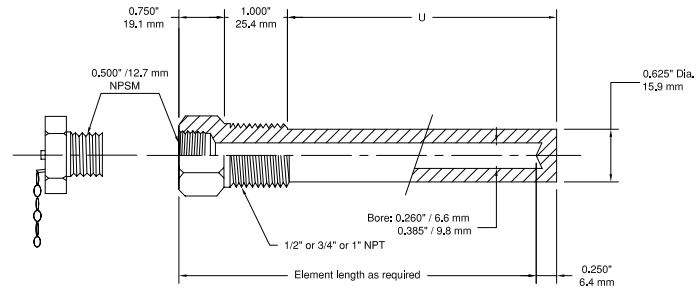

To order, please contact Winters;

1-800-WINTERS
(1-800-946-8377)

or visit us at
www.winters.com



Corporate Office: 121 Railside Road • Toronto, ON, M3A 1B2 • 416-444-2345 • Fax: 416-444-8979

U.S.A. Office: 600 Ensminger Road • Buffalo, NY, 14150 • 716 874 8700 • Fax: 716-874-8800

www.winters.com • 1-800-WINTERS (946-8377)

Thermowells

WELD-IN

New!

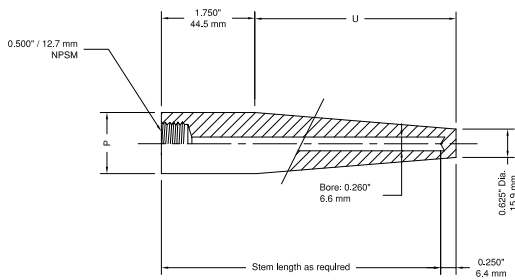

Features:

- 304 stainless steel or 316 stainless steel construction
- 1/2" NPSM thermometer connection
- 0.260" (6.604mm) bore standard (0.385 (9.779mm) bore available)
- 1 1/2" connection pipe size standard (Other configurations available)

How to order: Specify product code
PRODUCT CODES

Stem Length	"U" Dimension	Material	Code
4" (100mm)	2.5"	304 St/St.	TWW154304
4" (100mm)	2.5"	316 St/St.	TWW154316
6" (150mm)	4.5"	304 St/St.	TWW156304
6" (150mm)	4.5"	316 St/St.	TWW156316
9" (228.6mm)	7.5"	304 St/St.	TWW159304
9" (228.6mm)	7.5"	316 St/St.	TWW159316
12" (304.8mm)	10.5"	304 St/St.	TWW1512304
12" (304.8mm)	10.5"	316 St/St.	TWW1512316

Applications:

Utilized anywhere that a welded thermowell is required. Common applications include high pressure and/or high vibration, for example on the steam side of the construction of steam boilers.

Winters offers you a choice of many different thermowell materials to suit your application.

Some of the materials available include:

- Carbon steel
 - Brass
- 304 Stainless Steel
- 316 Stainless Steel
 - Titanium
 - Alloy 20
- Hastelloy B and C
 - Inconel
 - Monel
 - Nickel

Whatever your requirements are, Winters will have a thermowell to suit your application!

Notes:

- Winters offers Tapered Thermowells, Van Stone Thermowells and Threaded Thermowells for Industrial Glass Thermometers. Please contact Winters for more information.

- Please refer to the Industrial 5AS Thermometer for the Industrial 5AS Thermowell

- Please refer to the Industrial 9IT Thermometer page for the Industrial 9IT Thermowell



Corporate Office: 121 Railside Road • Toronto • ON • M3A 1B2 • (416) 444-2345 • Fax: (416) 444-8979

U.S.A. Office: 600 Ensminger Road • Buffalo • NY • 14150 • (716) 874-8700 • Fax: (716) 874-8800

www.winters.com • 1-800-WINTERS (946-8377)