

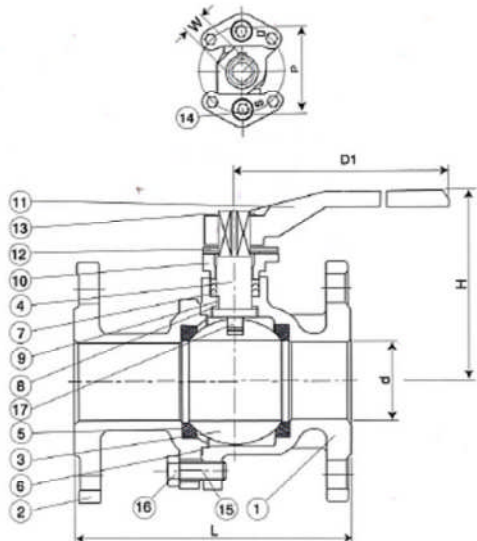

2-PC STAINLESS STEEL FULL PORT FLANGED BALL VALVE, ANSI 150/300 LB/JIS 10K/DIN PN 16

MODEL: #32SS WITH MOUNTING PAD ISO 5211



STANDARD
 DESIGN: ANSI B16.34
 FACE TO FACE: ANSI B16.10/JIS B2002/DIN PN16 3202 F4/F5
 FLANGE DIMENSIONS: ANSI B16.5/JIS B2210/DIN 2633 PN16
 TESTING: API 598

APPLICATION
 FOR GENERAL CHEMICAL AND INDUSTRIAL SERVICES
 PRESSURE-TEMPERATURE RATING: ANSI B16.34/JIS B2201

SPECIFICATION
 FIRE-SAFE DESIGN
 BODY MATERIAL: CF8M, CF8, CF3M

DIMENSIONS (inch)

| SIZE | d | L | | | H | D1 | P | W | 150LB LBS |
|--------|-------|-----------|-------|-------|-------|-------|------|------|--------------|
| | | 150LB/10K | 300LB | PN16 | | | | | |
| 1/2" | 0.59 | 4.25 | 5.51 | 4.53 | 3.23 | 4.92 | 1.65 | 0.39 | 4.52 |
| 3/4" | 0.79 | 4.61 | 5.98 | 4.72 | 3.35 | 4.92 | 1.65 | 0.39 | 4.63 |
| 1" | 0.98 | 5.00 | 6.50 | 4.92 | 3.70 | 5.71 | 1.97 | 0.47 | 6.83 |
| 1-1/4" | 1.26 | 5.51 | 7.01 | 5.12 | 3.94 | 5.71 | 1.97 | 0.47 | 8.82 |
| 1-1/2" | 1.57 | 6.50 | 7.48 | 5.51 | 4.53 | 9.06 | 2.76 | 0.67 | 15.21 |
| 2" | 1.97 | 7.01 | 8.50 | 5.91 | 4.72 | 9.06 | 2.76 | 0.67 | 18.19 |
| 2-1/2" | 2.56 | 7.48 | 9.49 | 6.69 | 6.10 | 15.75 | 4.02 | 0.79 | 30.75 |
| 3" | 3.15 | 7.99 | 11.10 | 7.09 | 6.50 | 15.75 | 4.02 | 0.79 | 39.24 |
| 4" | 3.94 | 9.02 | 12.01 | 7.48 | 7.87 | 18.11 | 4.02 | 1.06 | 69.34 |
| 5" | 4.92 | 14.02 | - | 12.80 | 8.66 | 18.11 | 4.02 | 1.06 | 101.63 |
| 6" | 5.91 | 15.51 | 15.87 | 13.78 | 10.04 | 31.50 | 4.92 | 1.26 | 144.18 |
| 8" | 7.87 | 17.99 | 19.76 | 15.75 | 11.81 | 39.37 | 5.51 | 1.42 | 357.15 |
| 10" | 9.84 | 20.98 | - | 17.72 | 14.17 | 39.37 | 6.50 | 1.42 | 496.04 |
| 12" | 11.81 | 24.02 | - | - | - | - | 6.50 | 1.81 | 797.63 |

MATERIAL LIST

| NO. | PART NAME | SPECIFICATION | QTY |
|-----|---------------|----------------|-------|
| 1 | BODY | ASTM A351 CF8M | 1 |
| 2 | CAP | ASTM A351 CF8M | 1 |
| 3 | BALL | ASTM A351 CF8M | 1 |
| 4 | STEM | ASTM A276-316 | 1 |
| 5 | SEATS | PTFE | 2 |
| 6 | GASKET | PTFE | 1 |
| 7 | STEM PACKING | PTFE | 1 SET |
| 8 | THRUST WASHER | PTFE | 1 |
| 9 | BEARING | PTFE | 1 |
| 10 | GLAND FLANGE | ASTM A351 CF8 | 1 |
| 11 | HANDLE | FCD45 | 1 |
| 12 | STOP PLATE | S.S. 304 | 1 |
| 13 | SNAP RING | S.S. 304 | 1 |
| 14 | GLAND BOLT | ASTM A193-B8 | 2-4 |
| 15 | BOLT | ASTM A193-B8 | 4-12 |
| 16 | NUT | ASTM A194-B | 4-12 |
| *17 | STATIC SPRING | S.S. 304 | 1-2 |

*Optional Device