



Flowseal high performance butterfly valves are available in sizes from 2" through 48" in ANSI pressure classes 150, 300, and 600 and are available with a diverse range of actuation options.

Flowseal is a leading provider of soft seat, metal seat and fire-safe high performance butterfly valves. Our products are manufactured under an ISO 9001 Quality Assurance Program that assures each valve we produce meets or exceeds your exacting application requirements.

Additionally, our Design and Manufacturing facility is certified to the Pressure Equipment Directive (PED), and Flowseal valves can be ordered as CE marked (see page 23).

Flowseal high performance butterfly valves are a standard in many industries including heating, ventilating and air conditioning, power generation, hydrocarbon processing, water and waste water treatment, and marine and commercial shipbuilding. Our products are also installed in applications as diverse as food and beverage processing, snowmaking and pulp and paper production. Configurations are available for harsh conditions as well as applications requiring nominal pressure and temperature ratings.

As part of Crane Valve Group, Flowseal high performance butterfly valves are backed by the resources and experience of one of the world's largest valve producers with a delivery and quality track record that is unparalleled in the industries we serve.

NOTE: In keeping with our policy of continuing improvement, we reserve the right to institute changes in design, material, dimensions, or specifications without notice and without incurring any obligation to make such changes and modifications on product previously or subsequently sold.

FLOWSEAL

High Performance Butterfly Valves

- Soft Seat
- Metal Seat
- Fire-Safe Seat
- ISO
- Marine
- Nuclear Power

Electric Actuators

- On/Off
- Modulating

Pneumatic Actuators

- Spring-Return
- Double Acting

Vane Actuators

- Double Acting
- Failsafe

Manual Operators

- Series W Gear Operators*
- Levers

Typical Applications

- Hydrocarbon Processing
- Chemical/Petrochemical Processing
- Power and Utilities
- Marine and Commercial Shipbuilding
- Power and Utilities
- Pulp and Paper

* For valves supplied with a chainwheel, the positive restraint option is recommended.

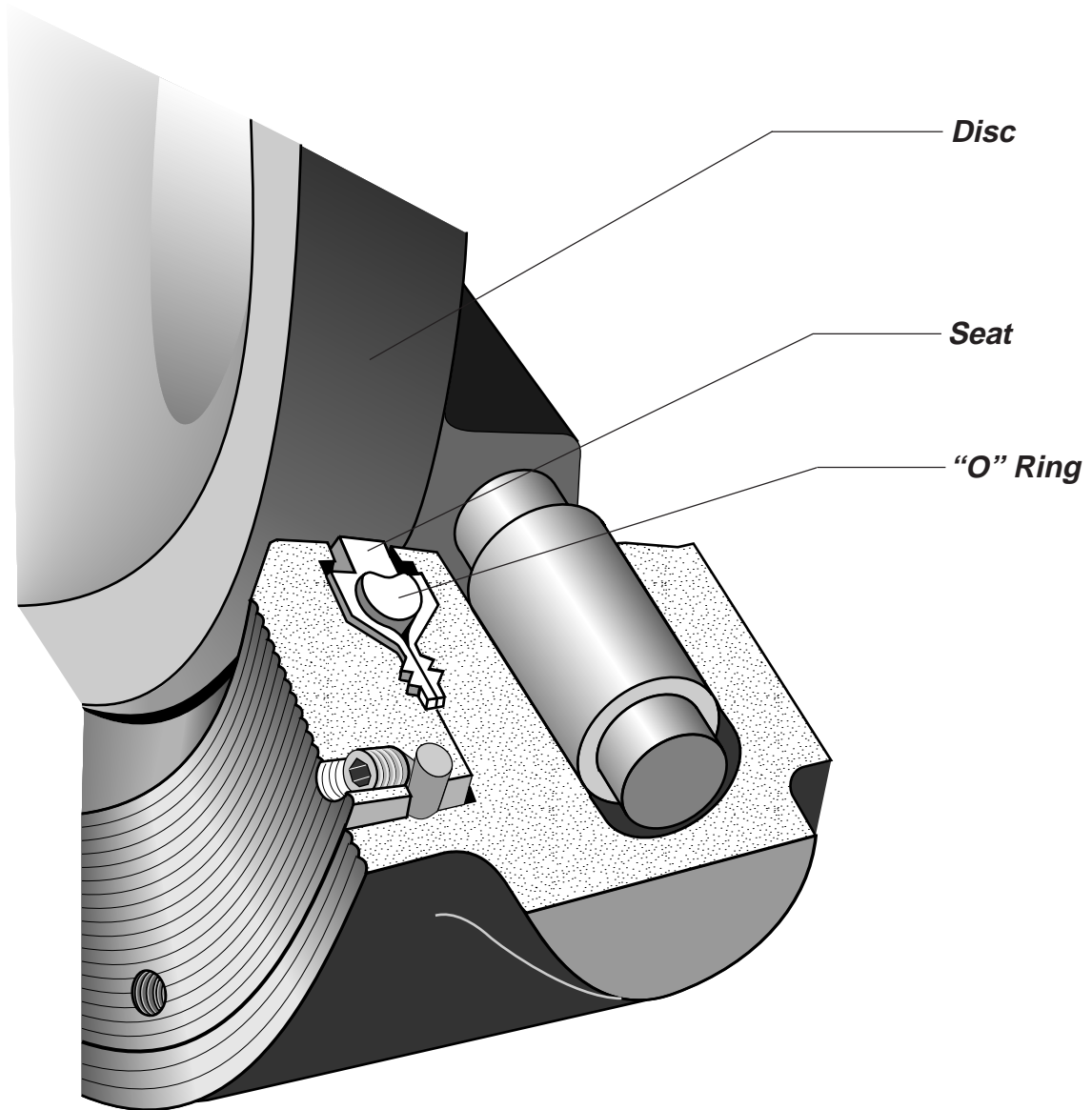

Flowseal is one of the world's leading manufacturers of high performance butterfly valves. Based on many years of research, development and field experience, the Flowseal design is superior to and more versatile than the High Performance Butterfly Valve design offered by other manufacturers.

The Flowseal Soft Seat valve provides a bi-directional bubble tight shutoff (zero leakage) by the use of a patented seat. This unique seat design creates a self-energized seal in vacuum-to-low pressure applications.

Under higher pressure conditions, the seat is also designed to permit, confine and direct movement of the soft seat against the disc edge, up to the full ANSI Class 150, 300 and 600 Cold Working Pressures.

The Soft Seat is designed for high services with minimal wear and low torque. Seat replacement is a simple operation, requiring no special tools.

DISC OPEN

In Figure 1, the disc and seat are not engaged. In this position, the shoulders of the seat are forced against the cavity shoulders by the compression of the o-ring.

The seat is recessed inside the seat cavity and acts as a gasket in the anchoring groove area. The seat cavity is sealed from exposure from the process fluid and protects the seat from abrasion and wear. The o-ring, which is completely encapsulated by the seat, is also isolated from exposure to the process fluid.

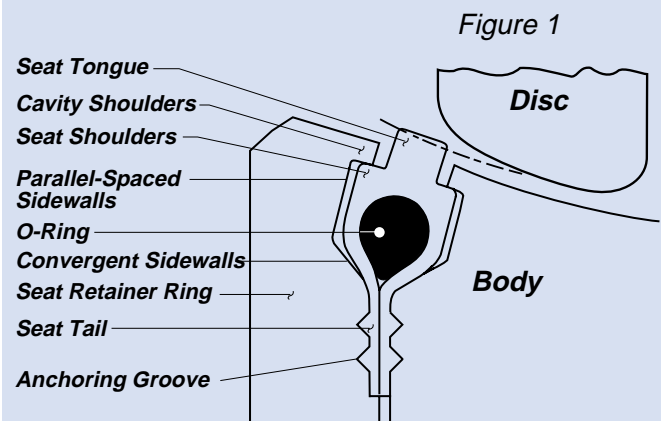

DISC CLOSED, Self-Energized Seal

In Figure 2, the Flowseal disc and seat are engaged, and the process fluid is under low pressure. The edge of the disc, with a larger diameter than the seat tongue, directs movement of the seat radially outward, causing the seat to compress against the convergent sidewalls of the cavity. The elastomeric o-ring imparts a mechanical pre-load between the disc and seat tongue as it is compressed and flattened by the disc; this is the self-energized mode for sealing at vacuum-to-60 psig.

As the seat moves radially outward, the seat shoulders move away from the cavity shoulders and open the cavity to the process media.

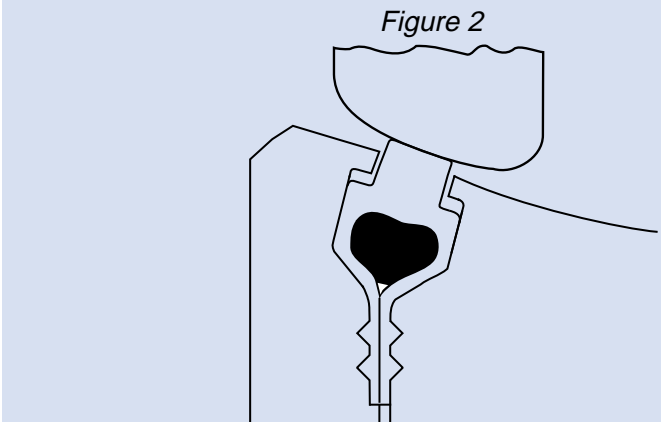

DISC CLOSED, Pressure-Energized Seal (Seat Upstream)

As line pressure increases, the process fluid enters the sidewall area and applies a load against the parallel-spaced sidewall and convergent sidewall of the seat. The seat and cavity design permits the seat to move axially to the downstream sidewall, but confines the movement and directs the movement radially inward towards the disc; the higher the line pressure, the tighter the seal between the disc and seat. Because the o-ring is elastic, it is able to flex and deform under loads and return to original shape after removal of the load; it is the rubber which deforms, not the thermoplastic material.

This dynamic seal, patented by Flowseal, is totally unique among high performance butterfly valves.

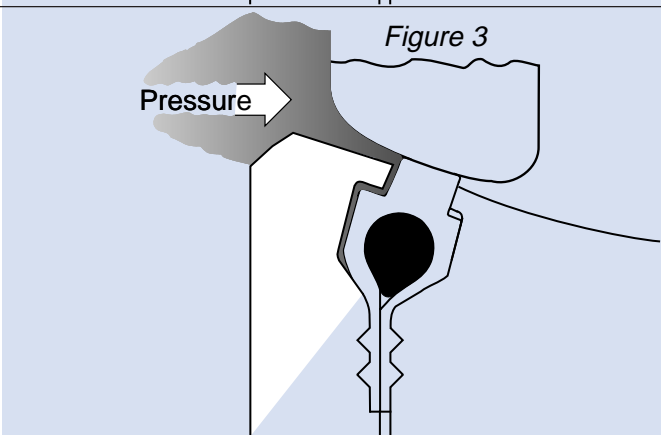

DISC CLOSED, Pressure-Energized Seal (Seat Downstream)

The Flowseal valve is bi-directional (in some instances, modifications may be required to operate this arrangement for dead end service). The cavity and seat sidewalls are symmetrically designed to permit, confine and direct movement of the seat to the disc to dynamically seal with line pressure in the reverse direction. The disc edge is the segment of a sphere, and the seat is angled towards the disc edge to seal with pipeline pressure in either direction.

Recommended installation direction is "SUS" (seat upstream), as in Figure 3.

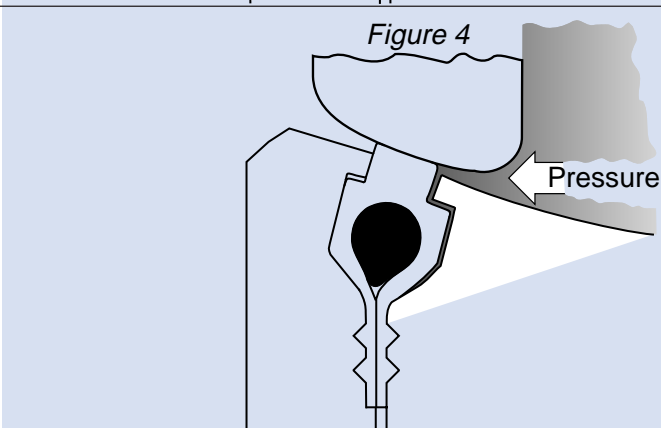

KEY

Square key valve-to-operator connection provides an externally controlled failure point upon over-torquing.

GLAND FLANGE

Applies load against packing gland to prevent external leakage. Fully adjustable.

PACKING

Chevron design TFE prevents external leakage out valve neck to full ANSI hydrostatic shell test pressures (150% of C.W.P.).

WEDGE RING

Stainless steel band wedged between valve body and retainer ring by set screws to lock seat and retainer ring in position on valve sizes 2" through 30". Socket head cap screws are used on valve sizes 36" and larger.

SET SCREWS

Cone point screws force wedge ring outward to lock seat retainer in position on valve sizes 2" through 30". Socket head cap screws are used on valve sizes 36" and larger.

OVERTRAVEL STOP

Prevents disc from rotating into the wrong quadrant.

SOFT-SEAT

Patented bi-directional seat with encapsulated elastomeric o-ring core for resiliency. Common seat materials include TFE, RTFE and UHMWPE.

BLOW OUT PROOF SHAFT

Solid shaft provides alignment and rigid support for disc.

PACKING GLAND

Separate part from gland flange, preventing uneven load distribution against packing.

BEARINGS

Both above and below the disc, bearings are of composite design: PTFE bonded to epoxy-glass filament wound ring. Used to align shaft, with high capacity, low wear, and low friction coefficient.

DISC SPACERS

Disc is centered by use of thrust spacers around shaft in sizes 2" to 5". Disc position stops or thrust bolt arrangements are used for larger valve sizes.

WEDGE PINS

Provide positive mechanical attachment of disc to shaft.

BODY

ANSI B16.34 design in either wafer or lug configuration.

DISC

360° uninterrupted spherical edge for sealing. Profile is designed for maximum flow and equal percentage control.

RETAINER RING

Retains seat in valve. Standard surface finish is 125 to 200 AARH and is compatible with both standard gaskets and spiral wound gasket designs. Outside diameter is recessed within gasket sealing surface to prevent external leakage.

End Seal Variation

The ANSI 150 14" through 24" sizes feature a two-piece shaft design. The lower shaft utilizes an end seal in the body to prevent external leakage. The component parts include an end seal, an end cap and end cap bolts.

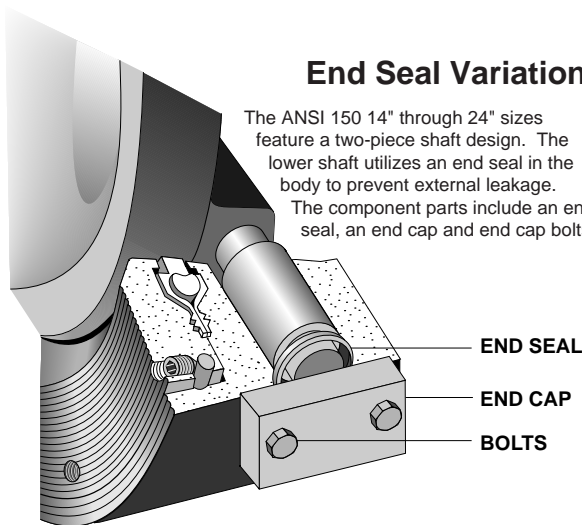

Lower Packing Variation

The ANSI 150 30" through 48"; ANSI 300 14" through 30"; ANSI 600 10" through 16" sizes feature a two-piece shaft design which utilizes a lower packing seal in the valve body to prevent external leakage. The component parts are of the same design used in the packing assembly in the top of the valve body neck.

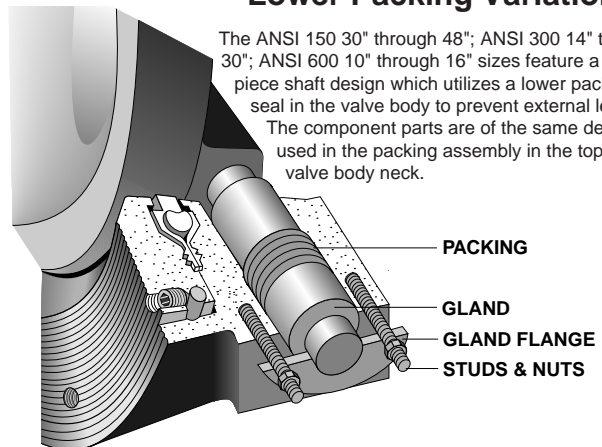

PRESSURE/TEMPERATURE RATINGS

As temperature increases, the pressure retaining capability of materials decreases. The graph below illustrates the pressure/temperature ratings of the Flowseal ANSI Class 150, Class 300 and Class 600.

The heavy lines define the ratings of the carbon steel and stainless steel valve body (or "shell") in conformance to ANSI B16.34. The shaded areas define the ratings of the TFE and RTFE Seat materials.

Seat ratings are based on differential pressure with the disc in the fully closed position.*

Steam Service

TFE seated valves are rated for 50 psi saturated steam.

Valves with "O" seat configuration (RTFE seat / AFLAS O ring) are rated to 100 psi steam service.

ANSI B16.34 Body and Flowseal Soft Seat Pressure - Temperature Ratings

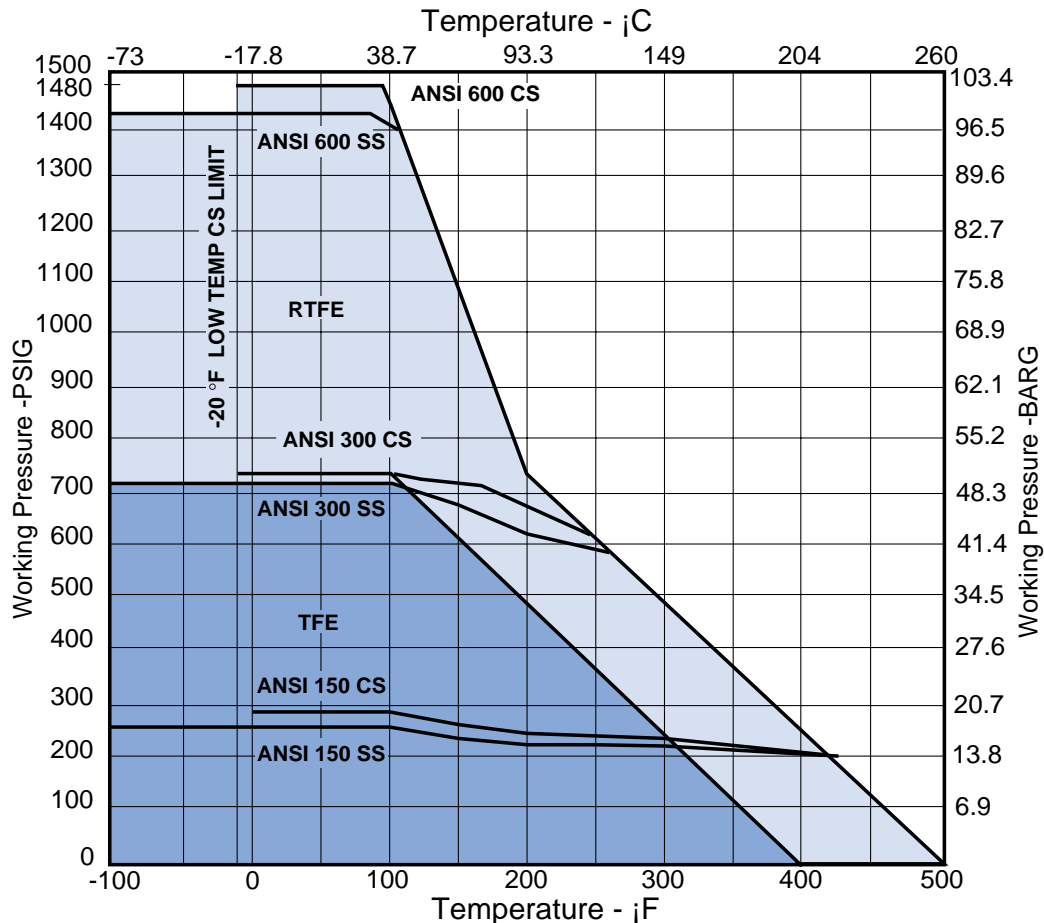

*Valves with 316 SS shafts are rated for maximum pressure differentials of 150 psi for Class 150, 300 psi for Class 300, and 600 psi for Class 600. (This does not apply to 2"-12" Soft Seat valves.)

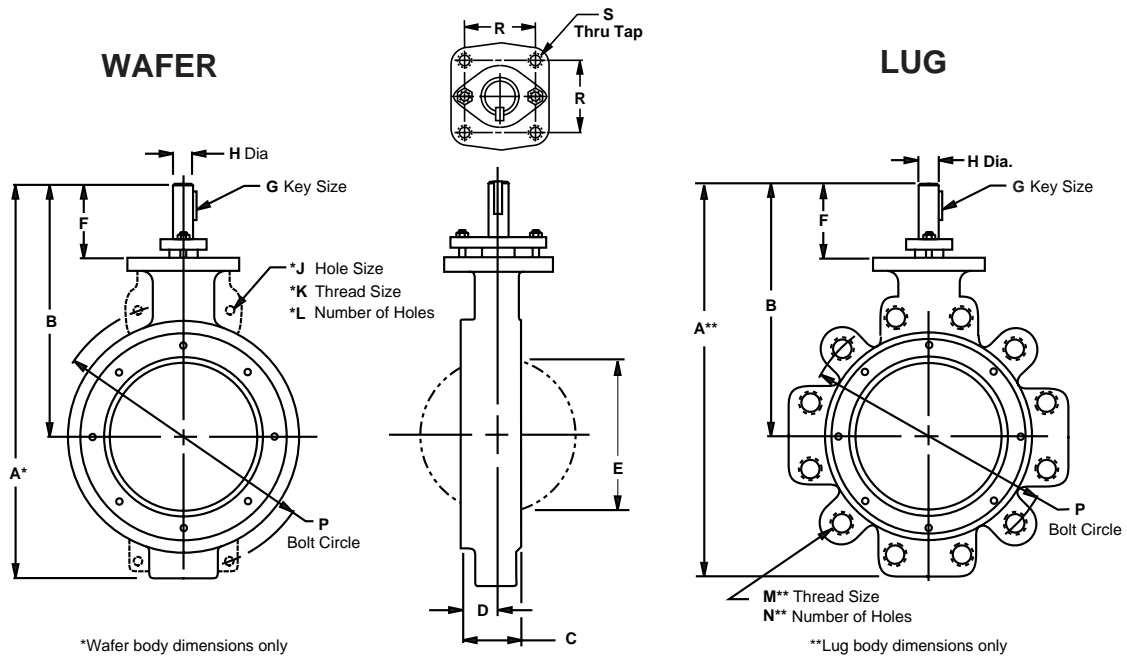

ANSI Class 150

VALVE SIZE	WAFER	LUG	B	C	D	E	F	G	H	J*	K*	L*	M**	N**	P	R	S	WEIGHT (LBS.)	
	A*	A**																WAFER	LUG
2"	10.59	10.59	7.59	1.75	1.06	1.72	3.34	3/16	.500	-	-	-	5/8-11	4	4.750	2.25	3/8-16	8	11
2.5"	10.30	10.30	7.59	1.88	1.09	2.09	3.34	3/16	.500	-	-	-	5/8-11	4	5.500	2.25	3/8-16	8	11
3"	11.60	11.98	8.60	1.92	1.20	2.75	3.60	3/16	.625	-	-	-	5/8-11	4	6.000	2.25	3/8-16	11	13
3.5"	11.97	11.97	8.72	2.05	1.30	3.19	3.60	3/16	.625	-	-	-	5/8-11	8	7.000	2.25	3/8-16	14	17
4"	12.92	13.55	9.42	2.13	1.26	3.62	3.67	3/16	.625	-	-	-	5/8-11	8	7.500	2.25	3/8-16	17	25
5"	14.53	15.16	10.28	2.25	1.34	4.55	3.81	1/4	.750	-	-	-	3/4-10	8	8.500	2.25	3/8-16	20	30
6"	15.69	15.93	10.81	2.29	1.38	5.55	3.81	1/4	.750	-	-	-	3/4-10	8	9.500	2.25	3/8-16	30	35
8"	17.81	17.94	11.93	2.50	1.49	7.28	3.80	3/8	1.000	-	-	-	3/4-10	8	11.750	2.25	3/8-16	44	48
10"	19.85	20.85	12.97	2.81	1.70	9.20	4.09	3/8	1.250	oval	-	2	7/8-9	12	14.250	3.25	3/8-16	71	91
12"	24.96	24.96	15.46	3.23	1.86	11.15	4.83	3/8	1.500	oval	-	2	7/8-9	12	17.000	3.25	3/8-16	110	127
14"	27.14	27.14	16.07	3.62	2.19	12.76	4.82	3/8	1.500	oval	-	4	1-8	12	18.750	3.25	3/8-16	135	183
16"	31.66	31.66	19.61	4.00	2.31	14.58	6.92	1/2	1.750	oval	-	4	1-8	16	21.250	4.25	1/2-13	182	250
18"	34.53	34.53	21.35	4.50	2.45	16.38	7.35	1/2	2.000	thru	-	4	1 1/8-8	16	22.750	4.25	1/2-13	234	305
20"	36.70	36.70	22.76	5.00	2.94	18.38	7.63	3/4	2.250	-	1 1/8-8	4	1 1/8-8	20	25.000	5.00	3/4-10	320	414
24"	41.57	41.57	25.13	6.06	3.12	21.88	7.88	3/4	2.500	-	1 1/4-8	4	1 1/4-8	20	29.500	5.00	3/4-10	505	702
30"	52.08	52.08	29.35	6.75	3.53	28.00	8.73	3/4	3.000	-	1 1/4-8	4	1 1/4-8	28	36.000	5.00	3/4-10	925	1130
36"	64.75	64.75	32.64	8.38	4.34	33.66	8.14	1	3.750	-	1 1/2-8	4	1 1/2-8	32	42.750	7.00	1-8	1630	1890
42"	73.24	73.24	37.62	9.25	5.03	40.31	9.62	1	4.500	-	1 1/2-8	4	1 1/2-8	36	49.500	7.00	1-8	2475	2700
48"	80.13	80.13	41.88	10.62	5.62	45.25	10.63	1 1/4	5.000	-	1 1/2-8	4	1 1/2-8	44	56.000	9.00	1-8	2815	3085

ANSI Class 300

VALVE SIZE	WAFER		LUG		B	C	D	E	F	G	H	J*	K*	L*	M**	N**	P	R	S	WEIGHT (LBS.)	
	A*	A**	WAFER	LUG																	
2"	10.59	10.59	7.59	1.75	1.06	1.72	3.34	3/16	.500	-	-	-	5/8-11	8	5.000	2.25	3/8-16	8	11		
2.5"	10.30	10.30	7.59	1.88	1.09	2.09	3.34	3/16	.500	-	-	-	3/4-10	8	5.880	2.25	3/8-16	8	11		
3"	11.60	11.98	8.60	1.92	1.20	2.75	3.60	3/16	.625	-	-	-	3/4-10	8	6.625	2.25	3/8-16	12	17		
3.5"	11.97	11.97	8.72	2.05	1.30	3.19	3.60	3/16	.625	-	-	-	3/4-10	8	7.250	2.25	3/8-16	14	19		
4"	12.92	13.54	9.42	2.13	1.25	3.62	3.67	3/16	.625	-	-	-	3/4-10	8	7.875	2.25	3/8-16	17	24		
5"	14.53	15.16	10.28	2.25	1.34	4.55	3.81	1/4	.750	-	-	-	3/4-10	8	9.250	2.25	3/8-16	20	30		
6"	15.93	16.31	10.81	2.29	1.38	5.55	3.81	3/8	1.000	-	-	-	3/4-10	12	10.625	2.25	3/8-16	30	49		
8"	18.10	19.50	12.22	2.88	1.54	7.06	4.08	3/8	1.250	-	-	-	7/8-9	12	13.000	3.25	3/8-16	52	80		
10"	21.60	22.10	14.22	3.25	1.70	9.00	4.84	3/8	1.500	-	1-8	2	1-8	16	15.250	3.25	3/8-16	88	115		
12"	28.40	28.40	17.90	3.62	1.86	10.72	6.90	1/2	1.750	-	1 1/8-8	4	1 1/8-8	16	17.750	4.25	1/2-13	153	199		
14"	34.31	34.31	19.74	4.62	2.48	12.08	7.36	1/2	2.000	-	1 1/8-8	4	1 1/8-8	20	20.250	4.25	1/2-13	285	324		
16"	38.14	38.14	21.82	5.25	2.59	13.72	7.82	3/4	2.250	-	1 1/4-8	4	1 1/4-8	20	22.500	5.00	3/4-10	336	401		
18"	40.26	40.26	23.00	5.88	3.03	15.56	7.87	3/4	2.500	-	1 1/4-8	4	1 1/4-8	24	24.750	5.00	3/4-10	393	517		
20"	43.62	43.62	25.13	6.31	3.24	17.22	8.74	3/4	3.000	-	1 1/4-8	4	1 1/4-8	24	27.000	5.00	3/4-10	510	735		
24"	49.94	49.94	28.27	7.19	3.62	20.61	8.89	1	3.500	-	1 1/2-8	4	1 1/2-8	24	32.000	7.00	1-8	733	1020		
30"	62.40	62.40	31.90	8.88	4.39	27.25	9.02	1	4.500	-	1 3/4-8	4	1 3/4-8	28	39.250	7.00	1-8	1745	2145		

ANSI Class 600

VALVE SIZE	WAFER		LUG		B	C	D	E	F	G	H	J*	K*	L*	M**	N**	P	R	S	WEIGHT (LBS.)	
	A*	A**	WAFER	LUG																	
2"	10.59	10.59	7.59	1.75	1.06	1.72	3.34	3/16	.500	-	-	-	5/8-11	8	5.000	2.25	3/8-16	11	13		
2.5"	10.30	10.30	7.59	1.88	1.09	2.14	3.34	3/16	.500	-	-	-	3/4-10	8	5.880	2.25	3/8-16	11	13		
3"	11.60	12.10	8.60	2.12	1.20	2.50	3.60	3/16	.625	-	-	-	3/4-10	8	6.625	2.25	3/8-16	13	18		
4"	14.43	14.93	9.81	2.50	1.40	3.43	3.81	1/4	.750	-	-	-	7/8-9	8	8.500	2.25	3/8-16	30	52		
6"	17.27	18.46	11.71	3.06	1.68	5.18	4.09	3/8	1.250	1 1/8	1-8	2	1-8	12	11.500	3.25	3/8-16	42	85		
8"	21.35	22.00	13.97	4.00	1.85	6.28	4.84	3/8	1.500	-	-	-	1 1/8-8	12	13.750	3.25	3/8-16	72	127		
10"	31.15	31.15	17.90	4.62	2.00	7.95	6.90	1/2	1.750	-	1 1/4-8	4	1 1/4-8	16	17.000	4.25	1/2-13	170	233		
12"	34.80	34.80	20.13	5.50	2.53	9.68	7.50	3/4	2.250	-	1 1/4-8	4	1 1/4-8	20	19.250	5.00	3/4-10	245	379		
16"	-	44.25	25.38	7.00	3.50	12.60	9.38	3/4	3.000	-	-	-	1 1/2-8	20	23.750	5.00	3/4-10	-	1170		

NOTES:

1. General

- Standard valves tested to MSS-SP-61. API-598 testing available on request.
- Valves for installation between DIN and JIS flanges available on application.
- Dimensions shown are for reference only. Certified drawings available on application.

2. For 2" through 24" sizes:

- Face-to-face dimensions (C) meet, within specified tolerance, MSS-SP-68 and API-609 requirements.
- Valves are designed for installation between ANSI B16.5 flanges.

3. For 30" through 48" sizes:

- Valves are designed for installation between ANSI/ASME B16.47 Class A flanges. (Class B on request)

4. For MIL SPEC valves, see Flowseal Marine Product Brochure.

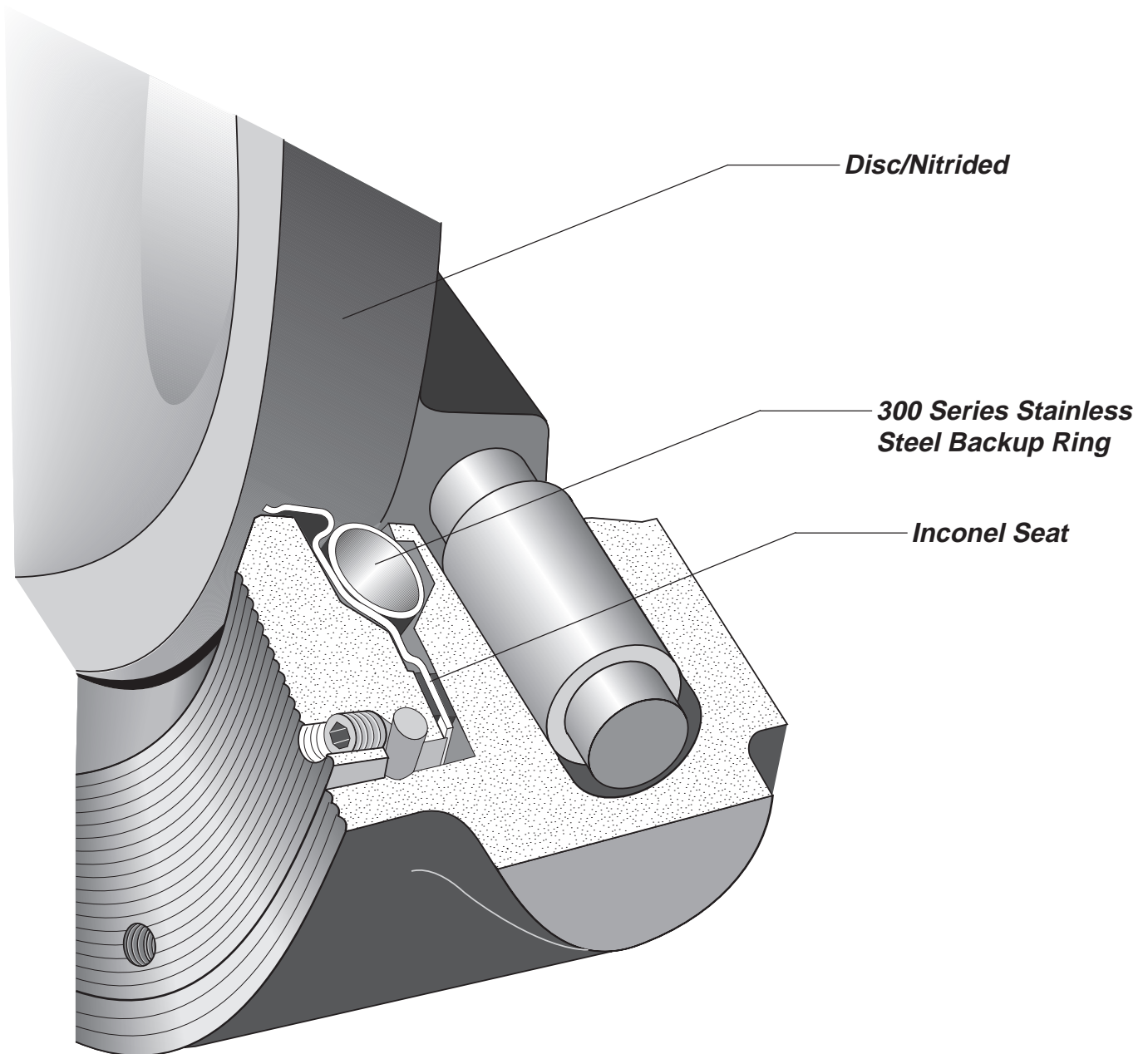

The Flowseal metal-to-metal seat high performance butterfly valve incorporates an Inconel seat for higher tensile strength, a 300 series stainless steel back-up ring in the seat cavity for axial seat support, and a disc that is case hardened by nitriding.

The Inconel seat, by its dynamic and flexible design, applies enough force per linear inch against the disc edge

(Rockwell Hardness of C66 to C70) to obtain an optimum sealing characteristic while controlling the loads between the metal surfaces.

The Flowseal metal-to-metal seat valve is utilized for temperatures up to 900°F, in compliance with ANSI B16.34 pressure/temperature specifications. Leakage is rated at Class IV per ANSI FCI 70-2.

PRINCIPLE OF METAL SEATING

Metal-to-metal sealing is accomplished by the “line contact” between a spherical surface and conical surface. Figure 1 illustrates a typical globe control valve seat and plug. The plug seating surface is the segment of a sphere; when engaged against the seat ring, a line contact seal is achieved.

In a metal seat design, it is necessary to apply enough force per linear inch to maintain a tight metal-to-metal contact between the sealing members; however, high linear thrust can cause a collapse of the seating members (“bearing failure”).

Figure 1

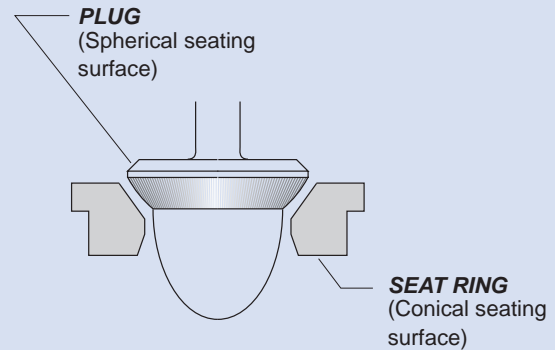

DISC CLOSED, Self-Energized Seal

In Figure 2, the Flowseal disc and seat are engaged, and the process fluid is under low pressure. The spherical edge of the disc, with a larger diameter than the conical seat tongue, imparts a thrust of approximately 600 pounds per linear inch against the seat. The mechanical properties and shape of the Inconel seat allow it to both flex and maintain a constant thrust against the disc.

This controlled loading prevents the occurrence of bearing failure and reduces the leakage and wear between the components.

Figure 2

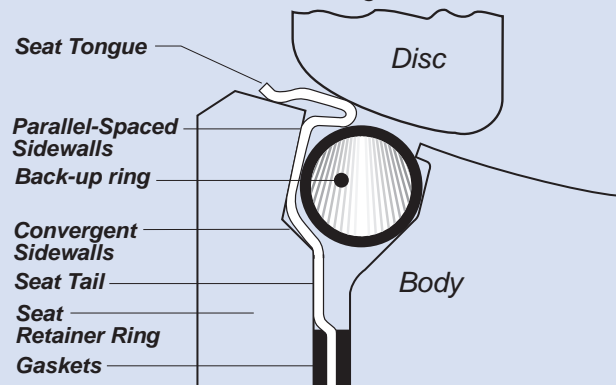

DISC CLOSED, Pressure-Energized Seal (Seat Upstream)

As line pressure increases, the process fluid enters the sidewall area and applies a load against the parallel-spaced sidewall and convergent sidewall of the metal seat. The seat moves towards the downstream sidewall while being supported axially by the support ring, as shown in Figure 3. The cavity shape confines the seat movement and directs the movement radially inward towards the disc; the higher the line pressure, the tighter the line contact between the disc and seat. The Inconel seat, shaped by a special hydroforming process, is able to flex under these loads and return to its original shape after removal of the loads.

This dynamic seal, patented by Flowseal, is totally unique among high performance butterfly valves.

Figure 3

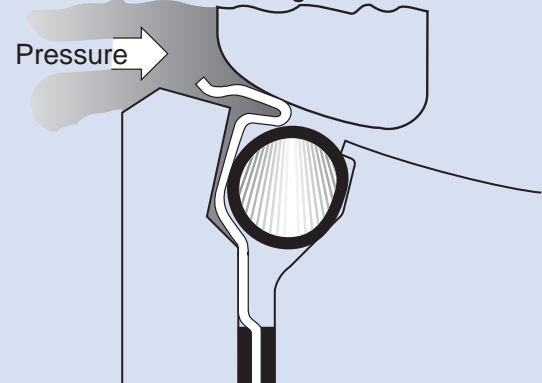

DISC CLOSED, Pressure-Energized Seal (Seat Downstream)

The Flowseal valve is bi-directional (in some instances, modifications may be required to operate this arrangement for dead end service). The cavity and seat sidewalls are symmetrically designed to permit, confine and direct movement of the seat to the disc to dynamically seal with line pressure in the seat downstream direction, as in Figure 4. Recommended installation direction is “SUS” (seat upstream), as in Figure 3.

The stainless steel back-up ring interacts dynamically with the metal seat for axial support in seat sealing. Additionally, this ring effectively restricts corrosion and particulate build-up in the cavity.

Figure 4

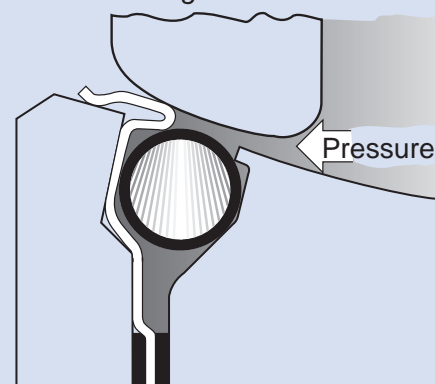

KEY

Square key valve-to-operator connection provides an externally controlled failure point upon over-torquing.

GLAND FLANGE

Applies load against packing gland to prevent external leakage. Fully adjustable.

PACKING

Common materials are TFE for up to 450 °F and Graphite for up to 900 °F.

WEDGE RING

Stainless steel band wedged between valve body and retainer ring by set screws to lock seat and retainer ring in position on valve sizes 2" through 30". Socket head cap screws are used on valve sizes 36" and larger.

WEDGE PINS

Provide positive mechanical attachment of disc to shaft.

OVERTRAVEL STOP

Prevents disc from rotating into wrong quadrant.

SET SCREWS

Cone point screws force wedge ring outward to lock seat retainer in position on valve sizes 2" through 30". Socket head cap screws are used on valve sizes 36" and larger.

METAL SEAT

Patented metal seat with metal back-up ring.

SHAFT

Solid shaft provides alignment and rigid support for disc.

PACKING GLAND

Separate part from gland flange, preventing uneven load distribution against packing.

BEARINGS

Both above and below the disc, bearings maintain shaft alignment. Common materials include:

- Glass-backed TFE for up to 450 °F. (Not for steam service.)
- Luberized Bronze for up to 750 °F.
- 300 Series Stainless Steel Nitrided for up to 900 °F.

DISC SPACERS

Disc is centered by use of thrust spacers around shaft in sizes 2" to 5". Disc position stops or thrust bolt arrangements are used for larger sizes.

BODY

ANSI B16.34 design in either wafer or lug configuration.

DISC

360° uninterrupted spherical edge for sealing. Profile is designed for maximum flow and equal percentage control. Disc seating surface is Nitrided for enhanced temperature and abrasion resistance

RETAINER RING

Retains seat in valve. Standard surface finish is 125 to 250 AARH and is compatible with both standard gaskets and spiral wound gasket designs. Outside diameter is recessed within gasket sealing surface to prevent external leakage.

End Seal Variation

The ANSI 150 14" through 24" sizes feature a two-piece shaft design. The lower shaft utilizes an end seal in the body to prevent external leakage. The component parts include an end seal, an end cap and end cap bolts.

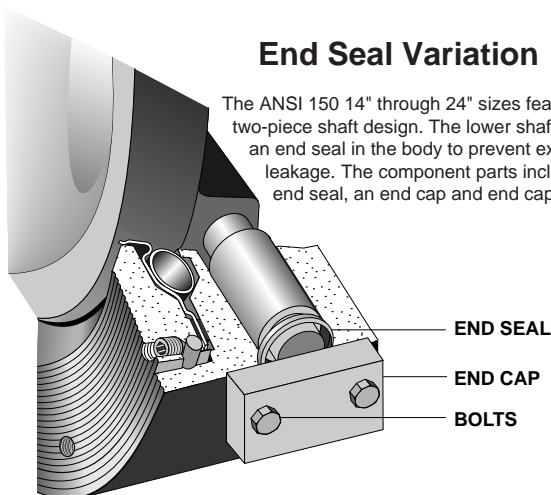

Lower Packing Variation

The ANSI 150 30" through 48"; ANSI 300 14" through 30"; ANSI 600 10" through 16" sizes feature a two-piece shaft design which utilizes a lower packing seal in the valve body to prevent external leakage. The component parts are of the same design used in the packing assembly in the top of the valve body neck.

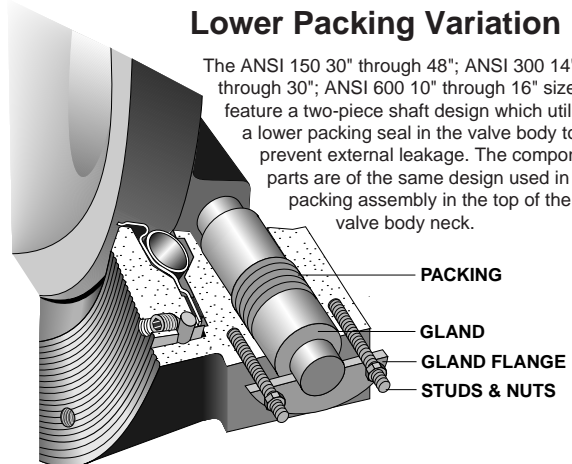

PRESSURE/TEMPERATURE RATINGS

As temperature increases, the pressure retaining capability of materials decreases. The graph below illustrates the pressure/temperature ratings of the Flowseal ANSI Class 150, Class 300 and Class 600.

The heavy lines define the ratings of the carbon steel and stainless steel valve body (or "shell") in conformance to ANSI B16.34. The shaded areas define the ratings of the metal seat.

Seat ratings are based on differential pressure with the disc in the fully closed position.

ANSI B16.34 Body and Flowseal Metal Seat Pressure - Temperature Ratings

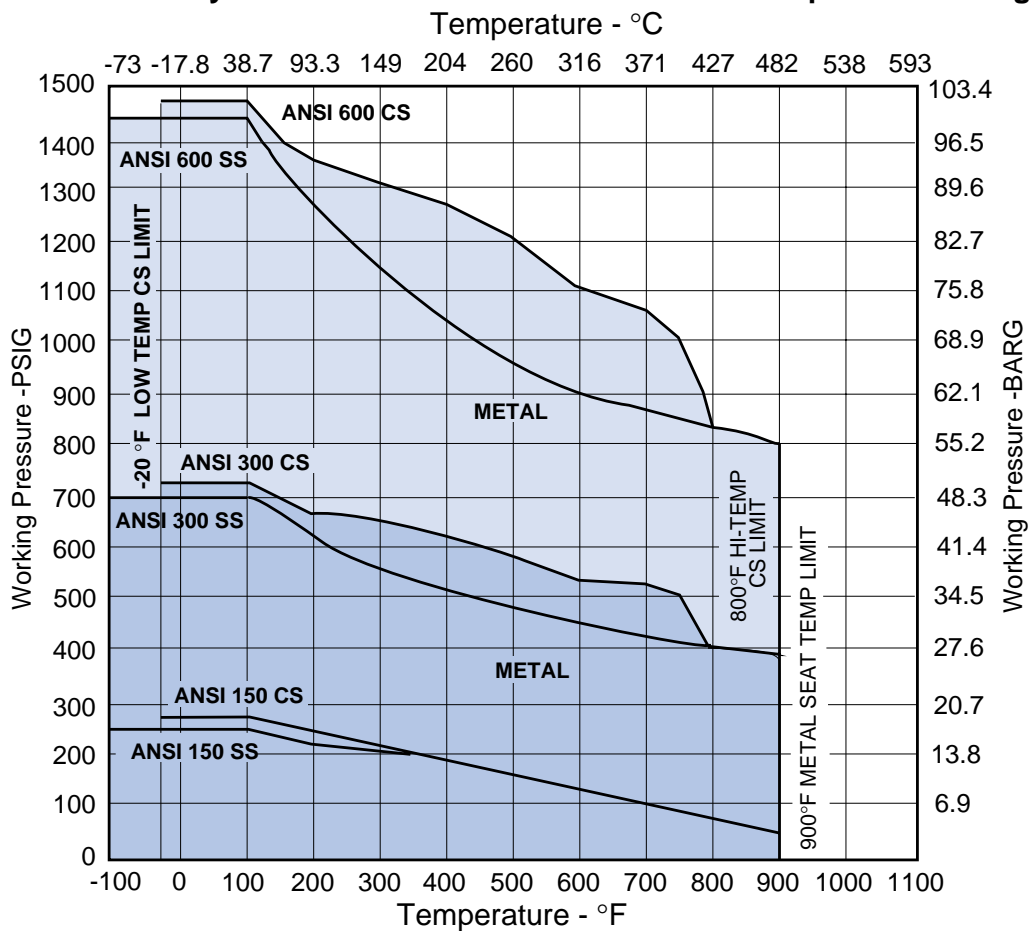

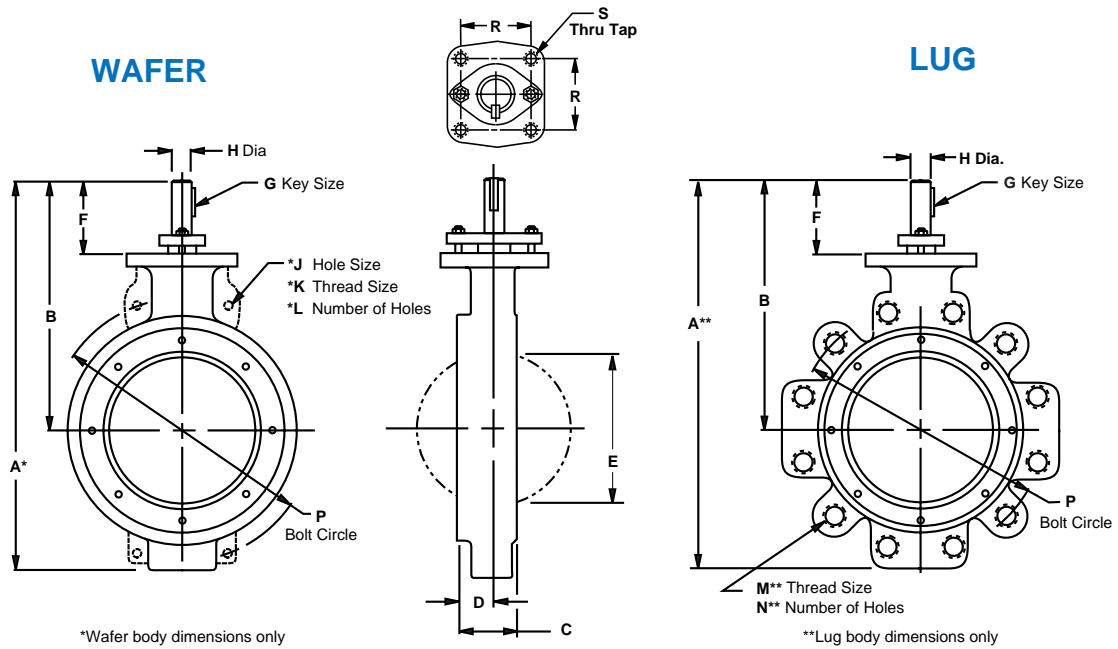

ANSI Class 150

VALVE SIZE	WAFER	LUG	B	C	D	E	F	G	H	J*	K*	L*	M**	N**	P	R	S	WEIGHT (LBS.)	
	A*	A**																WAFER	LUG
2"	10.59	10.59	7.59	1.75	1.06	1.72	3.34	3/16	.500	-	-	-	5/8-11	4	4.750	2.25	3/8-16	8	11
2.5"	10.30	10.30	7.59	1.88	1.09	2.09	3.34	3/16	.500	-	-	-	5/8-11	4	5.500	2.25	3/8-16	8	11
3"	11.60	11.98	8.60	1.92	1.20	2.75	3.60	3/16	.625	-	-	-	5/8-11	4	6.000	2.25	3/8-16	11	13
3.5"	11.97	11.97	8.72	2.05	1.30	3.19	3.60	3/16	.625	-	-	-	5/8-11	8	7.000	2.25	3/8-16	14	17
4"	12.92	13.55	9.42	2.13	1.26	3.62	3.67	3/16	.625	-	-	-	5/8-11	8	7.500	2.25	3/8-16	17	25
5"	14.53	15.16	10.28	2.25	1.34	4.55	3.81	1/4	.750	-	-	-	3/4-10	8	8.500	2.25	3/8-16	20	30
6"	15.69	15.93	10.81	2.29	1.38	5.55	3.81	1/4	.750	-	-	-	3/4-10	8	9.500	2.25	3/8-16	30	35
8"	17.81	17.94	11.93	2.50	1.49	7.28	3.80	3/8	1.000	-	-	-	3/4-10	8	11.750	2.25	3/8-16	44	48
10"	19.85	20.85	12.97	2.81	1.70	9.20	4.09	3/8	1.250	oval	-	2	7/8-9	12	14.250	3.25	3/8-16	71	91
12"	24.96	24.96	15.46	3.23	1.86	11.15	4.83	3/8	1.500	oval	-	2	7/8-9	12	17.000	3.25	3/8-16	110	127
14"	27.14	27.14	16.07	3.62	2.19	12.76	4.82	3/8	1.500	oval	-	4	1-8	12	18.750	3.25	3/8-16	135	183
16"	31.66	31.66	19.61	4.00	2.31	14.58	6.92	1/2	1.750	oval	-	4	1-8	16	21.250	4.25	1/2-13	182	250
18"	34.53	34.53	21.35	4.50	2.45	16.38	7.35	1/2	2.000	thru	-	4	1 1/8-8	16	22.750	4.25	1/2-13	234	305
20"	36.70	36.70	22.76	5.00	2.94	18.38	7.63	3/4	2.250	-	1 1/8-8	4	1 1/8-8	20	25.000	5.00	3/4-10	320	414
24"	41.57	41.57	25.13	6.06	3.12	21.88	7.88	3/4	2.500	-	1 1/4-8	4	1 1/4-8	20	29.500	5.00	3/4-10	505	702
30"	52.08	52.08	29.35	6.75	3.53	28.00	8.73	3/4	3.000	-	1 1/4-8	4	1 1/4-8	28	36.000	5.00	3/4-10	925	1130
36"	64.75	64.75	32.64	8.38	4.34	33.66	8.14	1	3.750	-	1 1/2-8	4	1 1/2-8	32	42.750	7.00	1-8	1630	1890
42"	73.24	73.24	37.62	9.25	5.03	40.31	9.62	1	4.500	-	1 1/2-8	4	1 1/2-8	36	49.500	7.00	1-8	2475	2700
48"	80.13	80.13	41.88	10.62	5.62	45.25	10.63	1 1/4	5.000	-	1 1/2-8	4	1 1/2-8	44	56.000	9.00	1-8	2815	3085

ANSI Class 300

VALVE SIZE	WAFER		LUG		B	C	D	E	F	G	H	J*	K*	L*	M**	N**	P	R	S	WEIGHT (LBS.)	
	A*	A**	WAFER	LUG																	
2"	10.59	10.59	7.59	1.75	1.06	1.72	3.34	3/16	.500	-	-	-	5/8-11	8	5.000	2.25	3/8-16	8	11		
2.5"	10.30	10.30	7.59	1.88	1.09	2.09	3.34	3/16	.500	-	-	-	3/4-10	8	5.880	2.25	3/8-16	8	11		
3"	11.60	11.98	8.60	1.92	1.20	2.75	3.60	3/16	.625	-	-	-	3/4-10	8	6.625	2.25	3/8-16	12	17		
3.5"	11.97	11.97	8.72	2.05	1.30	3.19	3.60	3/16	.625	-	-	-	3/4-10	8	7.250	2.25	3/8-16	14	19		
4"	12.92	13.54	9.42	2.13	1.25	3.62	3.67	3/16	.625	-	-	-	3/4-10	8	7.875	2.25	3/8-16	17	24		
5"	14.53	15.16	10.28	2.25	1.34	4.55	3.81	1/4	.750	-	-	-	3/4-10	8	9.250	2.25	3/8-16	20	30		
6"	15.93	16.31	10.81	2.29	1.38	5.55	3.81	3/8	1.000	-	-	-	3/4-10	12	10.625	2.25	3/8-16	30	49		
8"	18.10	19.50	12.22	2.88	1.54	7.06	4.08	3/8	1.250	-	-	-	7/8-9	12	13.000	3.25	3/8-16	52	80		
10"	21.60	22.10	14.22	3.25	1.70	9.00	4.84	3/8	1.500	-	1-8	2	1-8	16	15.250	3.25	3/8-16	88	115		
12"	28.40	28.40	17.90	3.62	1.86	10.72	6.90	1/2	1.750	-	1 1/8-8	4	1 1/8-8	16	17.750	4.25	1/2-13	153	199		
14"	34.31	34.31	19.74	4.62	2.48	12.08	7.36	1/2	2.000	-	1 1/8-8	4	1 1/8-8	20	20.250	4.25	1/2-13	285	324		
16"	38.14	38.14	21.82	5.25	2.59	13.72	7.82	3/4	2.250	-	1 1/4-8	4	1 1/4-8	20	22.500	5.00	3/4-10	336	401		
18"	40.26	40.26	23.00	5.88	3.03	15.56	7.87	3/4	2.500	-	1 1/4-8	4	1 1/4-8	24	24.750	5.00	3/4-10	393	517		
20"	43.62	43.62	25.13	6.31	3.24	17.22	8.74	3/4	3.000	-	1 1/4-8	4	1 1/4-8	24	27.000	5.00	3/4-10	510	735		
24"	49.94	49.94	28.27	7.19	3.62	20.61	8.89	1	3.500	-	1 1/2-8	4	1 1/2-8	24	32.000	7.00	1-8	733	1020		
30"	62.40	62.40	31.90	8.88	4.39	27.25	9.02	1	4.500	-	1 3/4-8	4	1 3/4-8	28	39.250	7.00	1-8	1745	2145		

ANSI Class 600

VALVE SIZE	WAFER		LUG		B	C	D	E	F	G	H	J*	K*	L*	M**	N**	P	R	S	WEIGHT (LBS.)	
	A*	A**	WAFER	LUG																	
2"	10.59	10.59	7.59	1.75	1.06	1.72	3.34	3/16	.500	-	-	-	5/8-11	8	5.000	2.25	3/8-16	11	13		
2.5"	10.30	10.30	7.59	1.88	1.09	2.14	3.34	3/16	.500	-	-	-	3/4-10	8	5.880	2.25	3/8-16	11	13		
3"	11.60	12.10	8.60	2.12	1.20	2.50	3.60	3/16	.625	-	-	-	3/4-10	8	6.625	2.25	3/8-16	13	18		
4"	14.43	14.93	9.81	2.50	1.40	3.43	3.81	1/4	.750	-	-	-	7/8-9	8	8.500	2.25	3/8-16	30	52		
6"	17.27	18.46	11.71	3.06	1.68	5.18	4.09	3/8	1.250	1 1/8	1-8	2	1-8	12	11.500	3.25	3/8-16	42	85		
8"	21.35	22.00	13.97	4.00	1.85	6.28	4.84	3/8	1.500	-	-	-	1 1/8-8	12	13.750	3.25	3/8-16	72	127		
10"	31.15	31.15	17.90	4.62	2.00	7.95	6.90	1/2	1.750	-	1 1/4-8	4	1 1/4-8	16	17.000	4.25	1/2-13	170	233		
12"	34.80	34.80	20.13	5.50	2.53	9.68	7.50	3/4	2.250	-	1 1/4-8	4	1 1/4-8	20	19.250	5.00	3/4-10	245	379		
16"	-	44.25	25.38	7.00	3.50	12.60	9.38	3/4	3.000	-	-	-	1 1/2-8	20	23.750	5.00	3/4-10	-	1170		

NOTES:

1. General

- Standard valves tested to MSS-SP-61 and ANSI/FCI 70-2, Class IV. API-598 testing available on request.
- Valves for installation between DIN and JIS flanges available on application.
- Dimensions shown are for reference only. Certified drawings available on application.

2. For 2" through 24" sizes:

- Face-to-face dimensions (C) meet, within specified tolerance, MSS-SP-68 and API-609 requirements.
- Valves are designed for installation between ANSI B16.5 flanges.

3. For 30" through 48" sizes:

- Valves are designed for installation between MSS-SP-44 flanges.

4. For MIL SPEC valves, see Flowseal Marine Product Brochure.

5. For ISO valves see, Flowseal ISO Product Brochure.

STANDARD MATERIALS OF CONSTRUCTION

Carbon Steel Construction

<i>COMPONENTS</i>	<i>-20 °F to 450 °F 171MTG CONSTRUCTION</i>	<i>451 °F to 750 °F 171MGB CONSTRUCTION</i>	<i>751 °F to 800 °F 172MGS CONSTRUCTION</i>
BODY	Carbon Steel A216 Gr WCB, or A105	Carbon Steel A216 Gr WCB, or A105	Carbon Steel A216 Gr WCB, or A105
DISC	316 Stainless Steel A351 CF8M, or A182 F316 Nitrided	316 Stainless Steel A351 CF8M, or A182 F316 Nitrided	316 Stainless Steel A351 CF8M, or A182 F316 Nitrided
SHAFT & PINS	17-4 PH Stainless Steel A564 Gr 630	17-4 PH Stainless Steel A564 Gr 630	17-4 PH Stainless Steel A564 Gr 630
SEAT	Inconel	Inconel	Inconel
PACKING	PTFE	Graphite	Graphite
BEARINGS	Glass-Backed PTFE	Bronze	316 Stainless Steel Nitrided

Stainless Steel Construction

<i>COMPONENTS</i>	<i>-100 °F to 450 °F 271MTG CONSTRUCTION</i>	<i>451 °F to 750 °F 271MGB CONSTRUCTION</i>	<i>751 °F to 900 °F 272MGS CONSTRUCTION</i>
BODY	316 Stainless Steel A351 CF8M, or A182 F316	316 Stainless Steel A351 CF8M, or A182 F316	316 Stainless Steel A351 CF8M, or A182 F316
DISC	316 Stainless Steel A351 CF8M, or A182 F316 Nitrided	316 Stainless Steel A351 CF8M, or A182 F316 Nitrided	316 Stainless Steel A351 CF8M, or A182 F316 Nitrided
SHAFT & PINS	17-4 PH Stainless Steel A564 Gr 630	17-4 PH Stainless Steel A564 Gr 630	316 Stainless Steel* A479 Gr 316
SEAT	Inconel	Inconel	Inconel
PACKING	PTFE	Graphite	Graphite
BEARINGS	Glass-Backed PTFE	Bronze	316 Stainless Steel Nitrided

* Metal Seat Valves with 316 SS Shafts are rated for maximum pressure differentials of 150 psi for Class 150, 300 psi for Class 300 and 600 psi for Class 600. Monel, Nitronic 50 and Inconel 718 or X750 shafts may be substituted for higher pressure differentials at elevated temperatures. Consult factory for additional information.

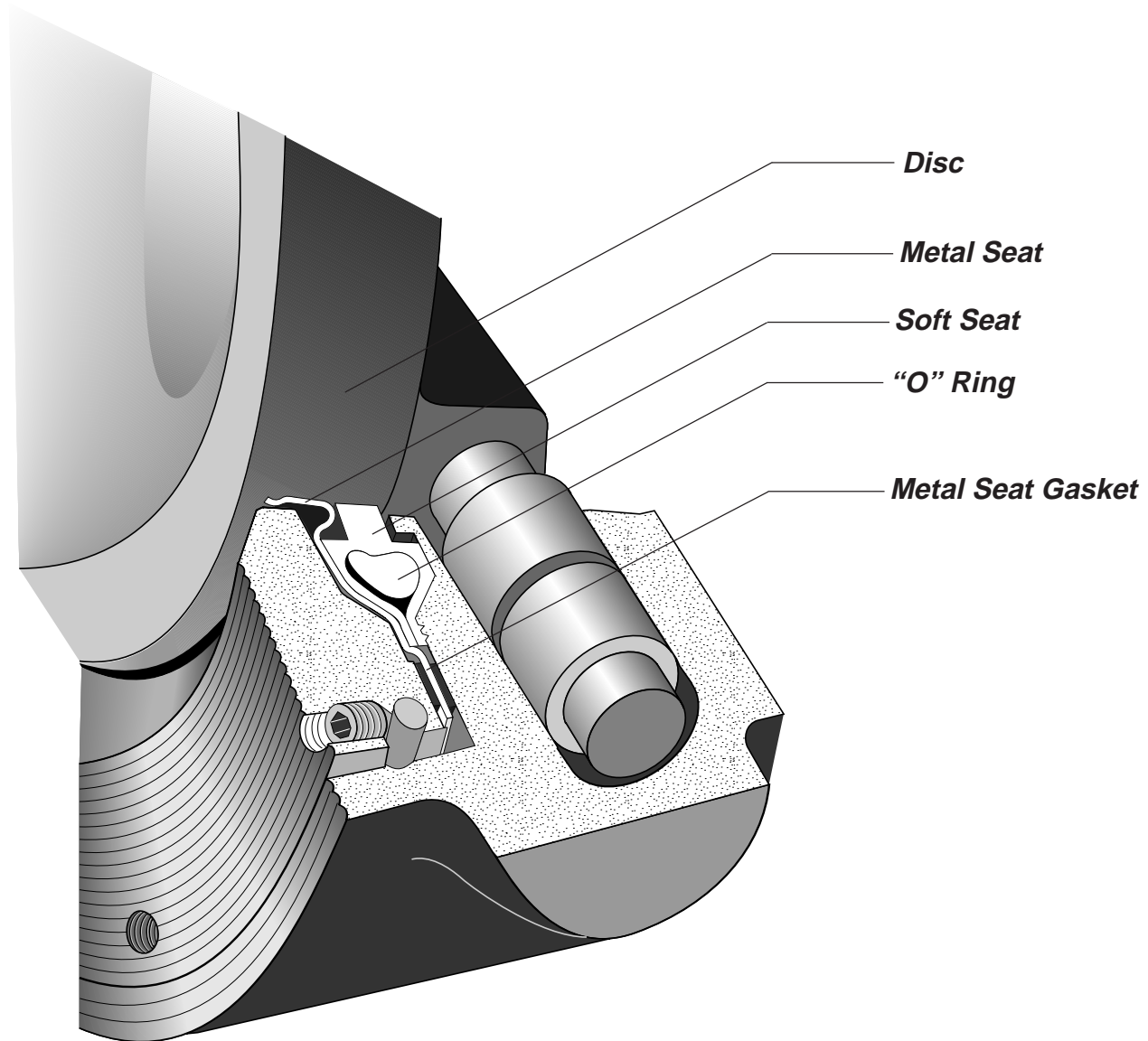

The Flowseal Fire-Flow™ high performance butterfly valve (HPBFV) is a fire-safe, soft seat quarter-turn valve. The Fire-Flow™ design incorporates two patented seats which function together to seal off pipeline flow. In normal operation, the soft seat provides a bi-directional "bubble tight" shutoff (zero leakage); the metal seat provides bi-directional shutoff in the event of a fire, in conformance to industry fire-safe requirements.

With little or no pressure, the Fire-Flow seat creates a self-energized seal against the disc. Higher line pressures act on the geometry of both seats to dynamically load them against the disc, creating higher sealing forces in either direction.

The Fire-Flow™ metal seat is made of Inconel material which is shaped by a proprietary hydroforming process into its unique, patented design. Stainless steel outer bearings are included for post-fire disc and shaft alignment. Fireproof packing is used to prevent external shaft leakage.

DISC OPEN, Normal Operation

In Figure 1, the disc and seat assembly are not engaged. In this position, the metal seat acts to keep the soft seat inside the seat cavity while the soft seat shoulders seal the cavity from exposure to the process fluid. (The o-ring is under tension and imparts a load against the soft seat.)

The soft seat is protected from abrasion and wear because it is recessed inside the seat cavity area. The o-ring is isolated from exposure to the fluid because it is completely encapsulated by the seat tails which act as a (soft) gasket in the anchoring groove area. The metal seat gaskets add further high temperature protection past the anchoring grooves.

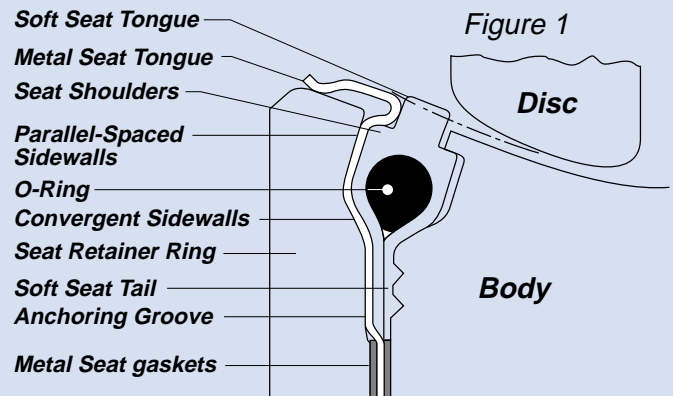

DISC CLOSED, Normal Operation

In Figure 2, the disc and seat assembly are engaged; both the metal seat and the soft seat are in contact with the disc. Under little to no pressure conditions, both seats are self-energized. The disc edge, with a larger diameter than the seat tongues, moves the seats radially outward; the metal seat shape, with a mechanical and dynamic flexibility, is designed to be hoop-loaded and impart a spring force against the disc, while the soft seat o-ring is stretched and flattened (without deformation of the material) and imparts a mechanical pre-load against the disc.

With increased line pressure, the process fluid enters the cavity sidewall area and applies loads against the seat sidewalls. The cavity design allows the seats to move toward the downstream sidewalls, but confines and directs the movement radially inward towards the disc; the higher the pressure the tighter the seal. The symmetrical shape and angle of the cavity permit the seal to be bi-directional.

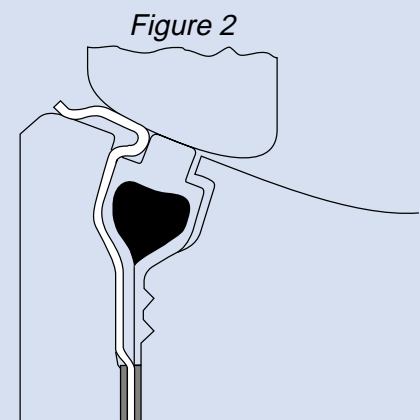

DISC CLOSED, After Fire (Seat Upstream)

After a fire, with partial or complete destruction of the soft seat, the metal seat maintains metal-to-metal contact with the disc and restricts leakage of the process fluid in conformance to industry fire-safe requirements.

With little or no line pressure, the spring force and hoop load of the metal seat maintain a "line contact" seal against the disc edge. Under higher pressures, the process fluid enters the cavity sidewall areas and applies loads against the seat sidewalls (Figure 3). The geometry of the metal seat permits the seat to move axially, but directs the movement radially inward toward the disc; The higher the pressure, the tighter the line contact seal.

Graphite gaskets, on both sides of the metal seat tail, seal the anchoring groove and prevent leakage of the process fluid.

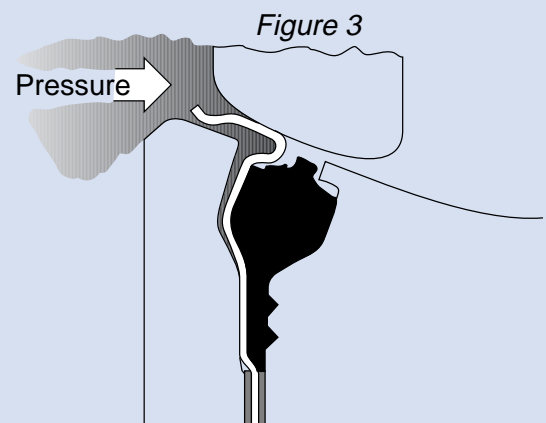

DISC CLOSED, After Fire (Seat Downstream)

The Flowseal Fire-Flow™ valve is bi-directional, however, modifications are required to operate for bi-directional dead end service. The angle and shape of the cavity and metal seat maintains metal-to-metal contact in the event of partial or complete soft seat destruction with line pressure in the reverse direction (Figure 4).

While the preferred flow direction is "seat upstream" (SUS), the bi-directional seat design is both self-energized and pressure-energized if the flow direction is "seat downstream" (SDS).

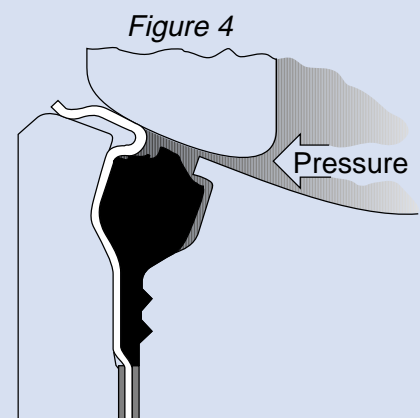

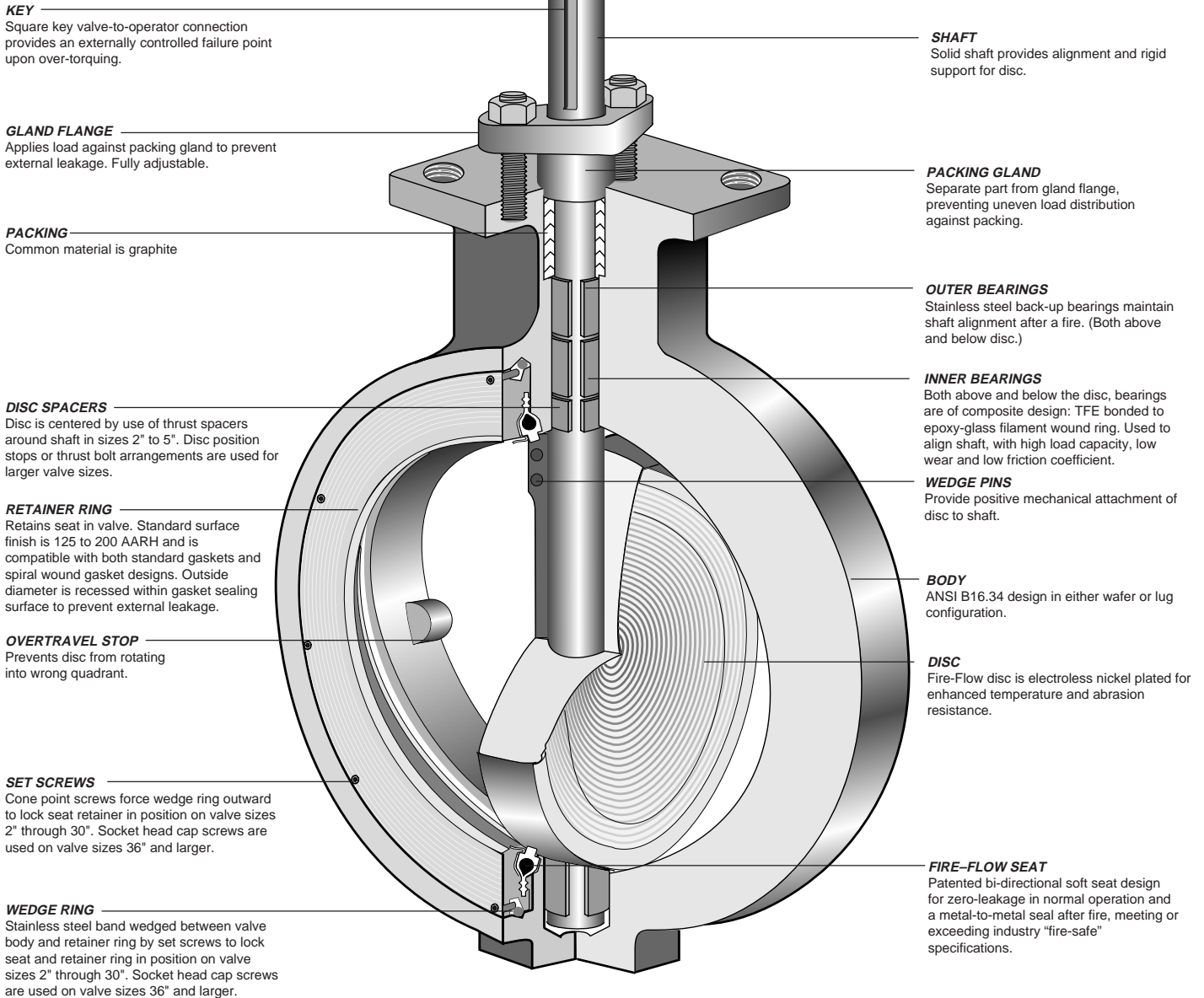

End Seal Variation

The ANSI 150 14" through 24" sizes feature a two-piece shaft design. The lower shaft utilizes an end seal in the body to prevent external leakage. The component parts include an end seal, an end cap and end cap bolts.

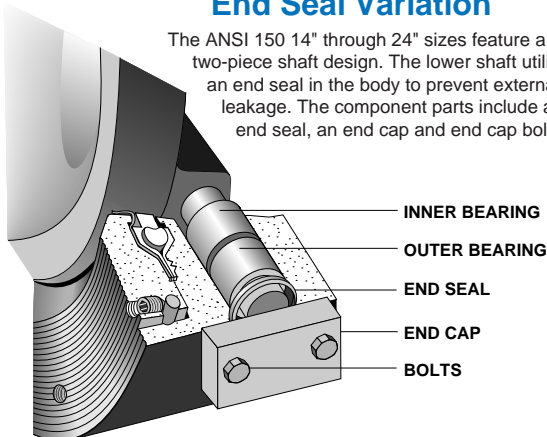

Lower Packing Variation

The ANSI 150 30" through 48"; ANSI 300 14" through 30"; ANSI 600 10" through 16" sizes feature a two-piece shaft design which utilizes a lower packing seal in the valve body to prevent external leakage. The component parts are of the same design used in the packing assembly in the top of the valve body neck.

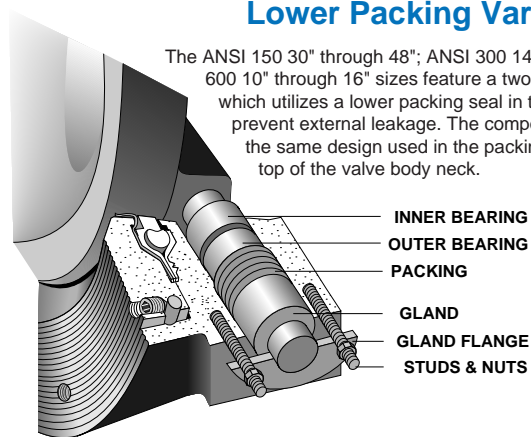

PRESSURE/TEMPERATURE RATINGS

As temperature increases, the pressure retaining capability of materials decreases. The graph below illustrates the pressure/temperature ratings of the Flowseal ANSI Class 150, Class 300 and Class 600.

The heavy lines define the ratings of the carbon steel and stainless steel valve body (or "shell") in conformance to ANSI B16.34. The shaded areas define the ratings of the soft seat.

Seat ratings are based on differential pressure with the disc in the fully closed position.

ANSI B16.34 Body and Flowseal Soft Seat Pressure - Temperature Ratings

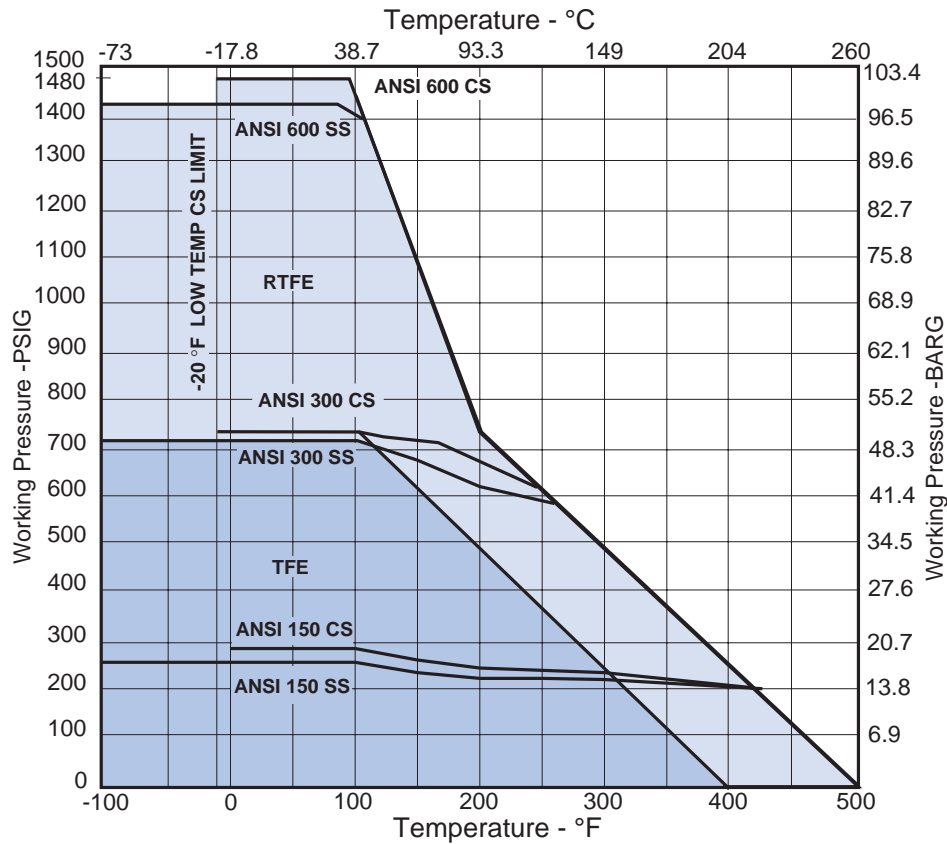

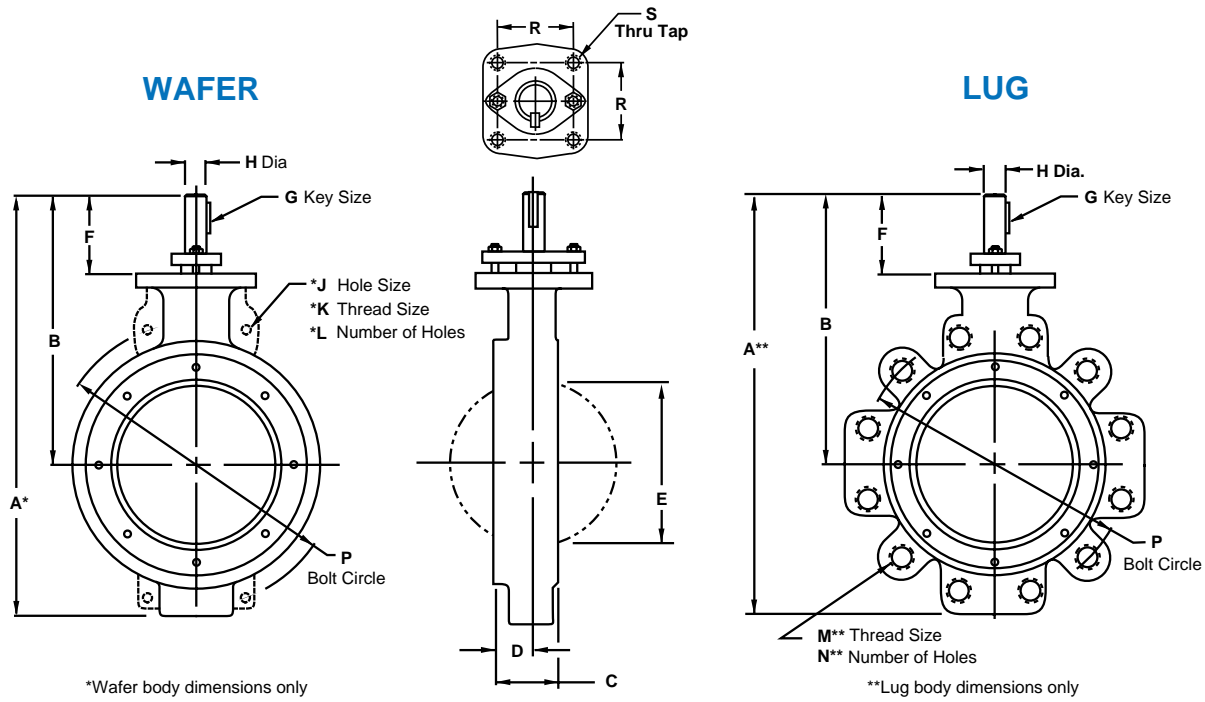

ANSI Class 150

VALVE SIZE	WAFER	LUG	B	C	D	E	F	G	H	J*	K*	L*	M**	N**	P	R	S	WEIGHT (LBS.)	
	A*	A**																WAFER	LUG
2"	10.59	10.59	7.59	1.75	1.06	1.72	3.34	3/16	.500	-	-	-	5/8-11	4	4.750	2.25	3/8-16	8	11
2.5"	10.30	10.30	7.59	1.88	1.09	2.09	3.34	3/16	.500	-	-	-	5/8-11	4	5.500	2.25	3/8-16	8	11
3"	11.60	11.98	8.60	1.92	1.20	2.75	3.60	3/16	.625	-	-	-	5/8-11	4	6.000	2.25	3/8-16	11	13
3.5"	11.97	11.97	8.72	2.05	1.30	3.19	3.60	3/16	.625	-	-	-	5/8-11	8	7.000	2.25	3/8-16	14	17
4"	12.92	13.55	9.42	2.13	1.26	3.62	3.67	3/16	.625	-	-	-	5/8-11	8	7.500	2.25	3/8-16	17	25
5"	14.53	15.16	10.28	2.25	1.34	4.55	3.81	1/4	.750	-	-	-	3/4-10	8	8.500	2.25	3/8-16	20	30
6"	15.69	15.93	10.81	2.29	1.38	5.55	3.81	1/4	.750	-	-	-	3/4-10	8	9.500	2.25	3/8-16	30	35
8"	17.81	17.94	11.93	2.50	1.49	7.28	3.80	3/8	1.000	-	-	-	3/4-10	8	11.750	2.25	3/8-16	44	48
10"	19.85	20.85	12.97	2.81	1.70	9.20	4.09	3/8	1.250	oval	-	2	7/8-9	12	14.250	3.25	3/8-16	71	91
12"	24.96	24.96	15.46	3.23	1.86	11.15	4.83	3/8	1.500	oval	-	2	7/8-9	12	17.000	3.25	3/8-16	110	127
14"	27.14	27.14	16.07	3.62	2.19	12.76	4.82	3/8	1.500	oval	-	4	1-8	12	18.750	3.25	3/8-16	135	183
16"	31.66	31.66	19.61	4.00	2.31	14.58	6.92	1/2	1.750	oval	-	4	1-8	16	21.250	4.25	1/2-13	182	250
18"	34.53	34.53	21.35	4.50	2.45	16.38	7.35	1/2	2.000	thru	-	4	1 1/8-8	16	22.750	4.25	1/2-13	234	305
20"	36.70	36.70	22.76	5.00	2.94	18.38	7.63	3/4	2.250	-	1 1/8-8	4	1 1/8-8	20	25.000	5.00	3/4-10	320	414
24"	41.57	41.57	25.13	6.06	3.12	21.88	7.88	3/4	2.500	thru	-	4	1 1/4-8	20	29.500	5.00	3/4-10	505	702
30"	52.08	52.08	29.35	6.75	3.53	28.00	8.73	3/4	3.000	-	1 1/4-8	4	1 1/4-8	28	36.000	5.00	3/4-10	925	1130
36"	64.75	64.75	32.64	8.38	4.34	33.66	8.14	1	3.750	-	1 1/2-8	4	1 1/2-8	32	42.750	7.00	1-8	1630	1890
42"	73.24	73.24	37.62	9.25	5.03	40.31	9.62	1	4.500	-	1 1/2-8	4	1 1/2-8	36	49.500	7.00	1-8	2475	2700
48"	80.13	80.13	41.88	10.62	5.62	45.25	10.63	1 1/4	5.000	-	1 1/2-8	4	1 1/2-8	44	56.000	9.00	1-8	2815	3085

ANSI Class 300

VALVE SIZE	WAFER		LUG		B	C	D	E	F	G	H	J*	K*	L*	M**	N**	P	R	S	WEIGHT (LBS.)	
	A*	A**	WAFER	LUG																	
2"	10.59	10.59	7.59	1.75	1.06	1.72	3.34	3/16	.500	-	-	-	5/8-11	8	5.000	2.25	3/8-16	8	11		
2.5"	10.30	10.30	7.59	1.88	1.09	2.09	3.34	3/16	.500	-	-	-	3/4-10	8	5.880	2.25	3/8-16	8	11		
3"	11.60	11.98	8.60	1.92	1.20	2.75	3.60	3/16	.625	-	-	-	3/4-10	8	6.625	2.25	3/8-16	12	17		
3.5"	11.97	11.97	8.72	2.05	1.30	3.19	3.60	3/16	.625	-	-	-	3/4-10	8	7.250	2.25	3/8-16	14	19		
4"	12.92	13.54	9.42	2.13	1.25	3.62	3.67	3/16	.625	-	-	-	3/4-10	8	7.875	2.25	3/8-16	17	24		
5"	14.53	15.16	10.28	2.25	1.34	4.55	3.81	1/4	.750	-	-	-	3/4-10	8	9.250	2.25	3/8-16	20	30		
6"	15.93	16.31	10.81	2.29	1.38	5.55	3.81	3/8	1.000	-	-	-	3/4-10	12	10.625	2.25	3/8-16	30	49		
8"	18.10	19.50	12.22	2.88	1.54	7.06	4.08	3/8	1.250	-	-	-	7/8-9	12	13.000	3.25	3/8-16	52	80		
10"	21.60	22.10	14.22	3.25	1.70	9.00	4.84	3/8	1.500	-	1-8	2	1-8	16	15.250	3.25	3/8-16	88	115		
12"	28.40	28.40	17.90	3.62	1.86	10.72	6.90	1/2	1.750	-	1 1/8-8	4	1 1/8-8	16	17.750	4.25	1/2-13	153	199		
14"	34.31	34.31	19.74	4.62	2.48	12.08	7.36	1/2	2.000	-	1 1/8-8	4	1 1/8-8	20	20.250	4.25	1/2-13	285	324		
16"	38.14	38.14	21.82	5.25	2.59	13.72	7.82	3/4	2.250	-	1 1/4-8	4	1 1/4-8	20	22.500	5.00	3/4-10	336	401		
18"	40.26	40.26	23.00	5.88	3.03	15.56	7.87	3/4	2.500	-	1 1/4-8	4	1 1/4-8	24	24.750	5.00	3/4-10	393	517		
20"	43.62	43.62	25.13	6.31	3.24	17.22	8.74	3/4	3.000	-	1 1/4-8	4	1 1/4-8	24	27.000	5.00	3/4-10	510	735		
24"	49.94	49.94	28.27	7.19	3.62	20.61	8.89	1	3.500	-	1 1/2-8	4	1 1/2-8	24	32.000	7.00	1-8	733	1020		
30"	62.40	62.40	31.90	8.88	4.39	27.25	9.02	1	4.500	-	1 3/4-8	4	1 3/4-8	28	39.250	7.00	1-8	1745	2145		

ANSI Class 600

VALVE SIZE	WAFER		LUG		B	C	D	E	F	G	H	J*	K*	L*	M**	N**	P	R	S	WEIGHT (LBS.)	
	A*	A**	WAFER	LUG																	
2"	10.59	10.59	7.59	1.75	1.06	1.72	3.34	3/16	.500	-	-	-	5/8-11	8	5.000	2.25	3/8-16	11	13		
2.5"	10.30	10.30	7.59	1.88	1.09	2.14	3.34	3/16	.500	-	-	-	3/4-10	8	5.880	2.25	3/8-16	11	13		
3"	11.60	12.10	8.60	2.12	1.20	2.50	3.60	3/16	.625	-	-	-	3/4-10	8	6.625	2.25	3/8-16	13	18		
4"	14.43	14.93	9.81	2.50	1.40	3.43	3.81	1/4	.750	-	-	-	7/8-9	8	8.500	2.25	3/8-16	30	52		
6"	17.27	18.46	11.71	3.06	1.68	5.18	4.09	3/8	1.250	1 1/8	1-8	2	1-8	12	11.500	3.25	3/8-16	42	85		
8"	21.35	22.00	13.97	4.00	1.85	6.28	4.84	3/8	1.500	-	-	-	1 1/8-8	12	13.750	3.25	3/8-16	72	127		
10"	31.15	31.15	17.90	4.62	2.00	7.95	6.90	1/2	1.750	-	1 1/4-8	4	1 1/4-8	16	17.000	4.25	1/2-13	170	233		
12"	34.80	34.80	20.13	5.50	2.53	9.68	7.50	3/4	2.250	-	1 1/4-8	4	1 1/4-8	20	19.250	5.00	3/4-10	245	379		

NOTES:

1. General

- Standard valves tested to MSS-SP-61. API-598 testing available on request.
- Valves for installation between DIN and JIS flanges available on application.
- Dimensions shown are for reference only. Certified drawings available on application.

2. For 2" through 24" sizes:

- Face-to-face dimensions (C) meet, within specified tolerance, MSS-SP-68 and API-609 requirements.
- Valves are designed for installation between ANSI B16.5 flanges.

3. For 30" through 48" sizes:

- Valves are designed for installation between MSS-SP-44 and ASME B16.47 flanges.

4. For MIL SPEC valves, see Flowseal Marine Product Brochure.

5. For ISO valves, see Flowseal ISO Product Brochure.

C_V FACTORS

C_V (Coefficient of Volume) is the number of U.S. gallons per minute of water required to pass through a valve with a pressure drop of 1 psi. The chart below records this C_V factor for the Flowseal valve classes and sizes at ten degree increments between open and closed. The values shown are for the valve installed in the seat upstream ("SUS") position.

Degree Open % Full C _V	10° 1.5%	20° 6%	30° 14%	40° 25.2%	50° 38%	60° 55%	70° 75%	80° 97%	90° 100%
2" 150	1.5	6	14	25	39	56	76	99	102
300	1.4	6	13	24	36	52	71	95	100
600	1.4	5	13	23	35	51	70	90	93
2-1/2" 150	2.2	9	21	37	56	80	110	142	146
300	2.1	8	19	34	52	75	102	136	143
600	2.0	8	19	33	51	73	100	130	133
3" 150	3.4	14	32	57	87	125	171	221	228
300	3.2	13	30	53	81	117	159	212	223
600	3.1	12	29	52	79	114	156	202	208
3-1/2" 150	5.3	21	49	88	132	192	261	338	349
300	4.8	19	45	80	121	176	240	320	336
4" 150	6.8	27	63	114	171	248	338	437	451
300	6.2	25	58	104	157	228	310	414	435
600	5.8	23	54	98	147	213	290	375	387
5" 150	10.8	43	100	180	271	392	535	692	714
300	9.8	40	92	165	248	361	491	655	688
6" 150	16.5	66	154	278	419	607	827	1070	1103
300	14.9	60	139	250	377	546	744	992	1041
600	14.7	59	137	247	372	538	734	950	979
8" 150	30.9	124	289	520	784	1135	1584	2002	2064
300	27.3	109	255	459	692	1001	1365	1820	1911
600	26.8	107	250	451	679	983	1341	1734	1788
10" 150	52.8	211	492	886	1336	1934	2638	3411	3517
300	45.6	183	426	767	1156	1673	2282	3042	3194
600	41.2	165	384	692	1044	1511	2060	2665	2747
12" 150	72.6	290	677	1219	1838	2660	3628	4690	4837
300	63.3	253	590	1063	1602	2319	3163	4217	4428
600	58.4	233	545	981	1479	2140	2918	3774	3891
14" 150	90	392	914	1646	2481	3592	4898	6530	6857
300	81	326	760	1368	2063	2986	4072	5430	5702
600	73	292	682	1228	1838	2680	3655	4727	4873
16" 150	132	531	1230	2229	3361	4865	6634	8845	9287
300	109	435	1015	1827	2755	3988	5438	7850	8243
600	96	385	899	1619	2423	3533	4818	6231	6424
18" 150	171	684	1596	3873	4332	6270	8550	11270	11400
300	139	555	1295	2331	3515	5088	6938	9250	9712
20" 150	207	828	1932	3478	5244	7590	10350	13800	14420
300	158	630	1470	2646	3990	5775	7875	10150	10658
24" 150	315	1260	2940	5292	7890	11550	15750	21000	22050
300	242	966	2254	4057	6118	8855	12075	16100	16205
30" 150	491	1965	4585	8253	12445	18012	24563	32750	34388
300	404	1614	3766	6779	10222	14795	20175	26900	28245
36" 150	707	2830	6602	11884	17920	25938	35370	45745	47160
42" 150	963	3851	8987	16176	24392	35304	48143	62264	64190
48" 150	1258	5030	11738	21128	31859	46111	62881	81324	83840

C_f FACTORS

The critical flow factor, C_f, expresses the valve pressure recovery ratio. It is equivalent to F_L in ISA nomenclature.

DISC DEGREE OPENING	15°	20°	25°	30°	35°	40°	45°	50°	55°	60°	65°	70°	75°	80°	85°	90°
SEAT UPSTREAM	.95	.91	.84	.81	.78	.80	.77	.74	.74	.73	.70	.66	.63	.60	.57	.53
SEAT DOWNSTREAM	.94	.89	.84	.82	.80	.77	.75	.72	.69	.66	.63	.60	.58	.55	.54	.53

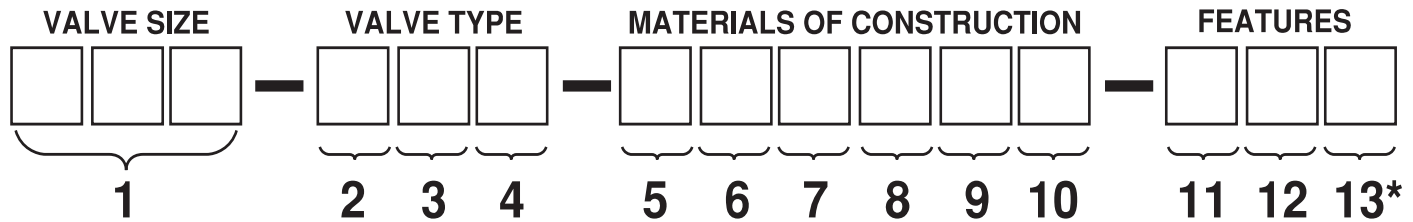

1. Size	Code
2"	02
2 1/2"	025
3"	03
3 1/2"	035
4"	04
to	
48"	48

2. Body Class	Code
150 PSI Max. Diff. Pressure	0
ANSI 150	1
ANSI 300	3
ANSI 600	6

3. Body Type	Code
Wafer	W
Lugged	L

4. Shaft Design	Code
Straight	A
2" - 24" ANSI 150	
2" - 12" ANSI 300	
2" - 8" ANSI 600	
Balanced	C
30" - 48" ANSI 150	
14" - 30" ANSI 300	
10" - 16" ANSI 600	

5. Body Material	Code
Carbon Steel	1
316 SS	2
Monel	3
Alloy 20	4
Alum Bronze MIL-B-24480	5
Alum Bronze B148 ASTM C958	8
Hastelloy C	H
Special	X

6. Disc Material	Code
Alum Bronze/ENP B148 C958	0
316 SS	2
Monel	3
Alloy 20	4
Alum Bronze MIL-B-24480	5
316 SS Nitrided	7
Alum Bronze B148 ASTM C958	8
316 SS/ENP	9
Hastelloy C	H
Hastelloy C/ENP	J
Special	X

7. Shaft Material	Code
17-4PH SS	1
316 SS (See Note 1)	2
Monel	3
Alloy 20	4
Inconel 718/750	6
Ferrallium A479	7
Nitronic 50	0
Hastelloy C	H
Special	X

8. Seat Material / O-Ring	Code
TFE / Viton	T
RTFE / Silicon	R
RTFE / AFLAS	O
Polyethylene (UHMWPE) / Viton	L
Fire-Flow (TFE & Metal) / Viton	F
Fire-Flow (RTFE & Metal) / Viton	B
Inconel	M
300 SS	S
Fire-Flow (TFE & Monel) / Viton	C
Fire-Flow (RTFE & Monel) / Silicon	J
Fire-Flow (TFE & Hastelloy C) / Viton	H
Fire-Flow (RTFE & Hastelloy C) / Silicon	K
Special	X

9. Packing Material	Code
TFE	T
Graphite	G
Fire-Flow	F
Special	X

10. Bearing Material	Code
Glass Backed TFE	G
316 SS Backed TFE	H
Fire-Flow (Garfil & 316 SS)	F
Stainless Steel Nitrided	S
Bronze	B
Monel	K
Hastelloy C Backed TFE	J
Special	X

11. Actuator Type	Code
Bare Shaft	B
Ratchet Handle	H
Ratchet Handle w/Lock	L
Throttle	T
Worm Gear	3
Pneumatic Double Acting	4
Pneumatic SR Fail Close	5
Pneumatic SR Fail Open	6
Hydraulic	7
Electric	8
Other	X

12. Special Feature	Code
None	O
Oxygen Service	A
Bi-directional	B
Chlorine Service	C
Dead-end Service (DDES)	D
CE Marked	P
CE Marked for DDES	E
Flat Face	F
Mil-V-24624	M
NACE Construction	N
60 to 125 AARH Facing	S
Vacuum Service	V
Special Feature	X
Further Description Required	

13. Series
*Factory Assigned

Note 1: Use of 316 SS shaft may lower shutoff differentials. Consult factory.

TYPICAL SOFT SEAT SPECIFICATION

1.0 Scope

This specification covers the design and testing of high pressure offset seat butterfly valves.

2.0 Applicable Standards

The following standards shall apply

ANSI B16.5:	Pipe Flanges and Flanged Fittings (24" size and smaller).
ANSI B16.34:	Valves—Flanged and Butt welding End.
MSS SP-25:	Standard Marking System for Valves, Fittings, Flanges and Unions.
MSS SP-61:	Pressure Testing of Steel Valves.
MSS SP-68:	High Pressure—Offset Seat Butterfly Valves.
API 609:	Butterfly Valves, Lug-Type and Wafer-Type.
PED	Pressure Equipment Directive Section H

3.0 Design Requirement

- 3.1 Valves shall be High Performance Butterfly with offset seat and eccentric shaft. They shall be capable of sealing against full differential pressure in either flow direction.
- 3.2 Valve seat shall be both self and pressure energized with an elastomeric core. The self energizing member shall be isolated from the line media.
- 3.3 Valves shall have retained top and bottom low friction bearings.
- 3.4 Shaft design shall be single or dual piece.
- 3.5 Retainer rings must be recessed in the body so that the line gasket prevents any potential external leakage.
- 3.6 Valves shall have internal stop to prevent disc over-travel.
- 3.7 Valves shall be Flowseal or approved equal.

4.0 Materials

- 4.1 Valves shall be constructed of new material.
- 4.2 Carbon steel valves shall be constructed from materials below:
 - 4.2.1 Body—ASTM A105 or A216 Gr. WCB.
 - 4.2.2 Disc—ASTM A182 F316 or A351 Gr. CF8M.
- 4.3 Stainless steel valves shall be constructed from materials below:
 - 4.3.1 Body—ASTM A182 Gr. F316 or A351 Gr. CF8M.
 - 4.3.2 Disc—ASTM A182 Gr. F316 or A351 Gr. CF8M.
- 4.4 Shafts shall be ASTM A564 type 630 H 1150 or 316 SS.

5.0 Inspection and Test

- 5.1 Valves shall be hydrostatically shell tested per ANSI B16.34 and MSS SP-61.
- 5.2 Valves shall be seat tested per MSS SP-61. No leakage is permitted for resilient seated valves.
- 5.3 API 598 testing available upon request.

Sample Figure Number
12 – 1WA – 121TTG – 30J

TYPICAL METAL SEAT SPECIFICATION

1.0 Scope

This specification covers the design and testing of high pressure offset seat butterfly valves.

2.0 Applicable Standards

The following standards shall apply

ANSI B16.5:	Pipe Flanges and Flanged Fittings (24" size and smaller).
ANSI B16.34:	Valves—Flanged and Butt welding End.
MSS SP-25:	Standard Marking System for Valves, Fittings, Flanges and Unions.
ANSI/FCI 70-2:	Control Valve Seat Leakage
MSS SP-68:	High Pressure—Offset Seat Butterfly Valves
API 609:	Butterfly Valves, Lug-Type and Wafer-Type.
PED	Pressure Equipment Directive Section H

3.0 Design Requirement

- 3.1 Valves shall be High Performance Butterfly with offset seat and eccentric shaft. They shall be capable of Class IV sealing in either flow direction.
- 3.2 Valve seat shall be both self and pressure energized.
- 3.3 Valves shall have retained top and bottom bearings.
- 3.4 Shaft design shall be single or dual piece.
- 3.5 Retainer rings must be recessed in the body so that the line gasket prevents any potential external leakage.
- 3.6 Valves shall have internal stop to prevent disc over-travel.
- 3.7 Valves shall be Flowseal or approved equal.

4.0 Materials

- 4.1 Valves shall be constructed of new material.
- 4.2 Carbon steel valves shall be constructed from materials below:
 - 4.2.1 Body—ASTM A105 or A216 Gr. WCB.
 - 4.2.2 Disc—ASTM A182 F316 or A351 Gr. CF8M.
- 4.3 Stainless steel valves shall be constructed from materials below:
 - 4.3.1 Body—ASTM A182 Gr. F316 or A351 Gr. CF8M.
 - 4.3.2 Disc—ASTM A182 Gr. F316 or A351 Gr. CF8M.
- 4.4 Shafts shall be ASTM A564 type 630 H 1150, or 316 SS.

5.0 Inspection and Test

- 5.1 Valves shall be hydrostatically shell tested per ANSI B16.34 and MSS SP-61.
- 5.2 Valves shall be seat tested per ANSI/FCI 70-2, Class IV.

Sample Figure Number
12 – 1WA – 171MTG – 30J

TYPICAL FIRE FLOW SPECIFICATION

1.0 Scope

This specification covers the design and testing of high pressure offset seat butterfly valves.

2.0 Applicable Standards

The following standards shall apply

ANSI B16.5:	Pipe Flanges and Flanged Fittings (24" size and smaller).
ANSI B16.34:	Valves—Flanged and Butt welding End.
MSS SP-25:	Standard Marking System for Valves, Fittings, Flanges and Unions.
MSS SP-61:	Pressure Testing of Steel Valves.
MSS SP-68:	High Pressure—Offset Seat Butterfly Valves.
API 609:	Butterfly Valves, Lug-Type and Wafer-Type.
API 607:	Fire Test for Soft-Seated Quarter Turn Valves.
PED	Pressure Equipment Directive Section H

3.0 Design Requirement

- 3.1 Valves shall be High Performance Butterfly with offset seat and eccentric shaft. They shall be capable of sealing against full differential pressure in either flow direction.
- 3.2 Valve seat shall be both self and pressure energized with an elastomeric core. The self energizing member shall be isolated from the line media.
- 3.3 Valves shall have retained top and bottom low friction bearings.
- 3.4 Shaft design shall be single or dual piece.
- 3.5 Retainer rings must be recessed in the body so that the line gasket prevents any potential external leakage.
- 3.6 Valves shall have internal stop to prevent disc over-travel.
- 3.7 Valves shall be Flowseal or approved equal.

4.0 Materials

- 4.1 Valves shall be constructed of new material.
- 4.2 Carbon steel valves shall be constructed from materials below:
 - 4.2.1 Body—ASTM A105 or A216 Gr. WCB.
 - 4.2.2 Disc—ASTM A182 F316 or A351 Gr. CF8M.
- 4.3 Stainless steel valves shall be constructed from materials below:
 - 4.3.1 Body—ASTM A182 Gr. F316 or A351 Gr. CF8M.
 - 4.3.2 Disc—ASTM A182 Gr. F316 or A351 Gr. CF8M.

5.0 Inspection and Test

- 5.1 Valves shall be hydrostatically shell tested per ANSI B16.34 and MSS SP-61.
- 5.2 Valves shall be seat tested per MSS SP-61. No leakage is permitted for resilient seated valves.
- 5.3 API 598 testing available upon request.
- 5.4 Flowseal Fire-Flow™ valves qualified to API 607 fire test standard.

Sample Figure Number
12 – 1WA – 191FFF – B0J

ELECTRIC – ON-OFF

Standard Features:

Torque Range – 347 lb ins to 17,359 lb ins
Housing – NEMA 4 & 4X
Electric Motor – 120 VAC, 1 PHASE, 60 Hz
Thermal Overload – Auto re-set
Limit Switches – Adjustable cam operated
Position Indicator – Mechanical Dial Type
Space Heater – Located in the control compartment
Terminal Strip – Pre-wired for motor & limit switches
Manual Override – Directing acting
Brake – “Lock-cut” gear arrangement
Adjustable Mechanical Travel Stops
Temperature Range – 13°F to 150°F
Mounting – Direct mount to Center Line valves
Certification/Approvals – CSA-NRTL/C

Optional Features:

AC Voltages – 220VAC, 1 PHASE, 60 Hz
AC Voltages – 24 VAC 44005 - 44400
DC Voltages – 12/24 VDC 4005 - 44300
Additional Limit Switches – 2 SPDT
Torque Switches – Adjustable open and close
Feedback Potentiometer – 500 ohm
Feedback Transmitter – 4-20 mA
De-clutchable Handwheel Override



ELECTRIC – MODULATING

Standard Features:

Process Control Signal – 4-20 mA, 0-10 VDC
Torque Range – 347 lb ins to 17,359 lb ins
Housing – NEMA 4 & 4X
Electric Motor – 120 VAC, 1 PHASE, 60 Hz
Thermal Overload – Auto re-set
Resolution – 400 increments through 90 degrees
Position Indicator – Mechanical Dial Type
Space Heater – Located in the control compartment
Terminal Strip – Pre-wired for motor & limit switches
Manual Override – Directing acting
Brake – “Lock-cut” gear arrangement
Adjustable Mechanical Travel Stops
Temperature Range – 130°F to 1500°F
Mounting – Direct mount to Center Line valves
Certification/Approvals – CSA-NRTL/C

Optional Features:

AC Voltages – 220VAC, 1 PHASE, 60 Hz
AC Voltages – 24 VAC 44010M - 44200M
Torque Switches – Adjustable open and close
De-clutchable Handwheel Override

PNEUMATIC – DOUBLE ACTING

Standard Features:

Torque Range – 80 lb ins to 60,623 lb ins
 Housing – Cast alloy aluminum, polyurethane coated
 Mounting – ISO 5211
 Top and Solenoid Mounting Pad – NAMUR
 Position Indicator – Mechanical “Cap” Type
 Operating Pressure – 20 to 120 PSIG
 Temperature Range – 4°F to 175°F
 Size Range – 12 models to choose from
 Adjustable Travel Stops – Both directions
 Mounting – Direct mount to Center Line valves

Optional Features:

Temperature Range – 4°F to 250°F, -40°F to 175°F
 Solenoid Valves – 3 or 4 way
 Limit Switches – Adjustable cam operated
 Positioners – Pneumatic or Electro-pneumatic
 DC-1 Dribble Control – Two-stage shutoff
 180° Actuation – 2 or 3 position
 Manual Override – De-clutchable gear type
 Speed Controls – Adjust cycle time
 Special Applications – Offshore, nuclear, hygienic, and gas or oil operation



PNEUMATIC – SPRING RETURN

Standard Features:

Torque Range – 80 lb ins to 41,341 lb ins
 Housing – Cast alloy aluminum, polyurethane coated
 Mounting – ISO 5211
 Top and Solenoid Mounting Pad – NAMUR
 Position Indicator – Mechanical “Cap” Type
 Operating Pressure – 20 to 120 PSIG
 Temperature Range – 4°F to 175°F
 Size Range – 12 models to choose from
 Adjustable Travel Stops – Both directions
 Mounting – Direct mount to Center Line valves

Optional Features:

Temperature Range – 4°F to 250°F, -40°F to 175°F
 Solenoid Valves – 3 or 4 way
 Limit Switches – Adjustable cam operated
 Positioners – Pneumatic or Electro-pneumatic
 DC-1 Dribble Control – Two-stage shutoff
 180° Actuation – 2 or 3 position
 Manual Override – De-clutchable gear type
 Speed Controls – Adjust cycle time
 Special Applications – Offshore, nuclear, hygienic, and gas or oil operation
