

spirax sarco®

SMC32 and SMC32Y Carbon Steel Bimetallic Steam Trap

The SMC32 and SMC32Y are carbon steel maintainable bimetallic steam traps with straight connections. The SMC32 has an integral flat strainer screen and the SMC32Y has an integral cylindrical Y-type strainer.

Model ⇄	SMC32	SMC32Y
PMO	465 psig	
Sizes	1/2", 3/4", and 1"	
Connections	NPT, SW, FLG ANSI 150 & 300	
Construction	Forged steel body and cover, stainless steel internals	
Options	Blowdown valve for SMC32Y.	

Typical Applications

Kitchen and laundry equipment, steam tracers, hospital equipment, steam coils, steam radiators and steam main drip stations.



Limiting Operating Conditions (ISO 6552)

Body design conditions		PN40	
PMA	-Maximum allowable pressure	725 psig	50 barg
TMA	-Maximum allowable temperature	752°F	400°C
PMO	-Maximum operating pressure	464 psig	32 barg
TMO	-Maximum operating temperature	662°F	300°C
Designed for a maximum cold hydraulic test pressure of		1088 psig	75 barg

Note: PMA & TMA are pressure/temperature related - see chart below.

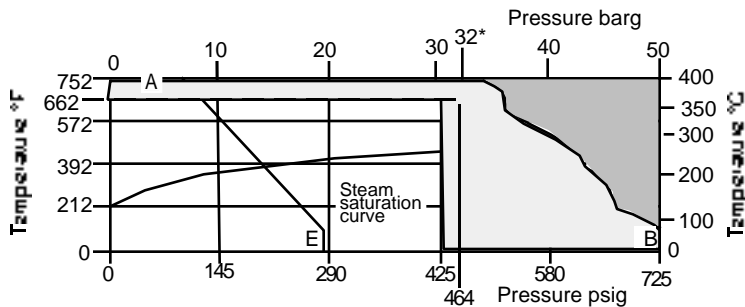
Operating range



 The product must not be used in this region.
 The product should not be used in this region or beyond its operating range as damage to the internals may occur.

Materials

No.	Part	Material
1	Cover	Carbon steel DIN 17243 C22.8 (W/S 1.0460) ASTM A105N
2	Bimetallic element	Corrosion resistant bimetal and stainless steel Rau Type H46
3	Valve seat	Stainless steel BS 970 431 S29
4	Locking nut	Stainless steel
5	Strainer screen	Stainless steel AISI 304
6	Valve	Stainless steel
7	Cover gasket	Stainless steel reinforced exfoliated graphite
8	Body	Carbon steel DIN 17243 C22.8 (W/S 1.0460) ASTM A105N
9	Cover bolts	Stainless steel (M10 x 30) A2 - 70
10	Strainer cap	Carbon steel DIN 17243 C22.8 (W/S 1.0460) ASTM A105N
11	Strainer cap gasket	Stainless steel BS 1449 304 S16

SMC32

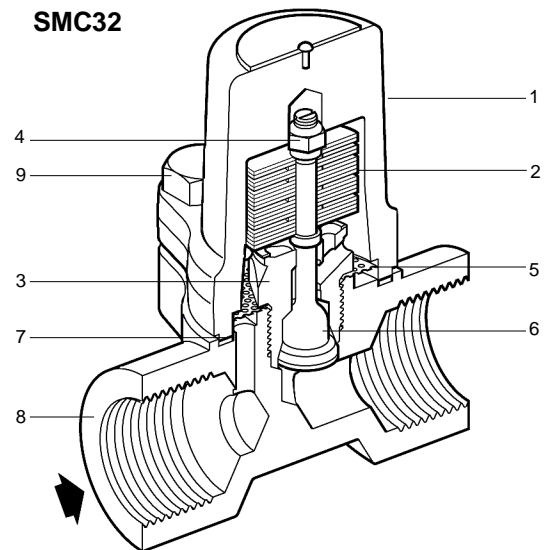

SMC32Y

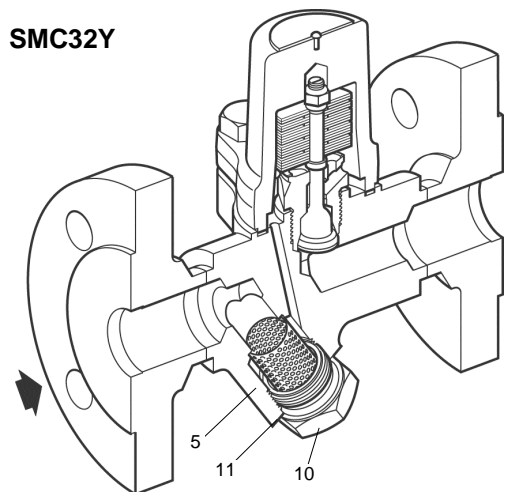

Local regulation may restrict the use of this product below the conditions quoted. Limiting conditions refer to standard connections only.
 In the interests of development and improvement of the product, we reserve the right to change the specification.

TI-P076-10 US 4.04

SMC32 and SMC32Y Carbon Steel Bimetallic Steam Trap

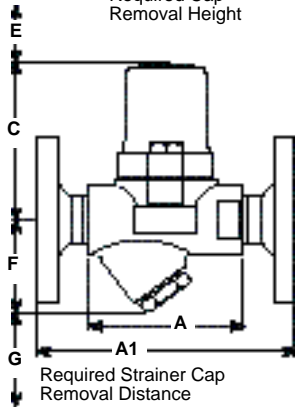
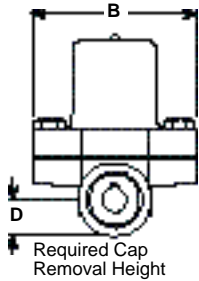

Dimensions (NOMINAL) IN INCHES AND MILLIMETERS										WEIGHT SCR/BW	WEIGHT FLGD
Size	A	A1	B	C	D	E	F	G			
SMC32											
1/2" DN15	3.7 95	5.9 150	3.7 94	3.6 92	0.7 17	2.0 51	-	-	-	3.8 lb 1.47kg	6.8 lb 3.1kg
3/4" DN20	3.7 95	5.9 150	3.7 94	3.6 92	0.7 17	2.0 51	-	-	-	3.8 lb 1.7 kg	8.2 lb 3.7kg
1" DN25	3.7 95	5.9 160	3.7 94	3.6 92	0.7 23	2.0 51	-	-	-	4.0 lb 1.8 kg	9.7lb 4.4 kg
SMC32Y											
1/2" DN15	3.7 95	5.9 150	3.7 94	3.6 92	-	2.0 51	2.1 53	1.1 28		4.2 lb 1.9kg	7.3 lb 3.3kg
3/4" DN20	3.7 95	5.9 150	3.7 94	3.6 92	-	2.0 51	2.1 54	1.1 28		4.2 lb 1.9kg	8.8 lb 4.0kg
1" DN25	3.7 95	6.3 160	3.7 94	3.6 92	-	2.0 51	2.3 58	1.1 28		4.4 lb 12.0kg	10.4 lb 4.7kg

Sample Specification

Steam trap shall be Spirax Sarco SMC32/SMC32Y bimetallic-type which self-adjusts to all pressures to 464 psig. Body construction of forged steel with side inlet and outlet threaded (or socket weld) ends containing an integral stainless steel strainer. Shall be provided with blowdown when required, and be maintainable in the field without disturbing the piping. Operating bimetal of design capable of resisting waterhammer and freezing conditions, and can withstand up to 662°F temperatures.

Capacities

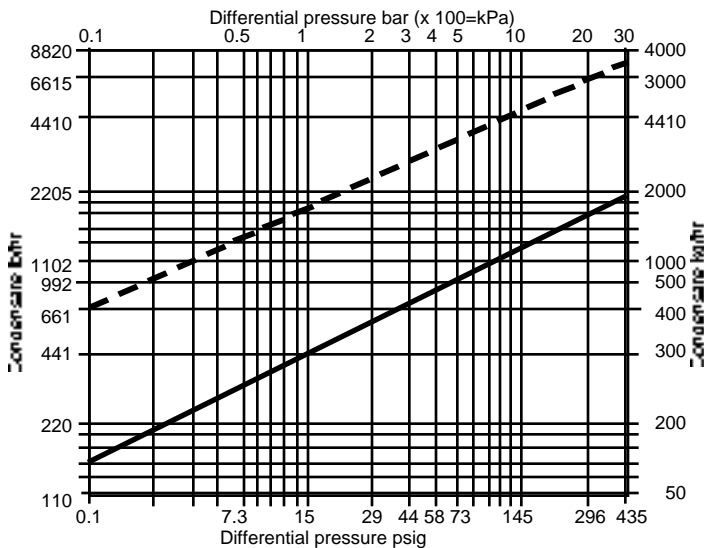

Installation

The trap is designed for installation with the bimetal in a horizontal plane and the cover at the top, preferably with a drop leg immediately preceding the trap. When welding the trap into the pipeline, there is no need to remove the element, providing the welding is done by the electric arc method. Full port isolating valves should be installed upstream and downstream of the trap.

Maintenance

This product can be maintained without disturbing the piping connections. Complete isolation of the connector from both supply and return line is required before any servicing is performed. The trap should be disassembled periodically for cleaning of the strainer screen and inspection and cleaning of the valve head and seat. Worn or damaged parts should be replaced using a complete Bimetal Assembly Set.

Complete installation and maintenance instructions are given in the IM-P076-09 sheet, which accompanies the product.

Spare parts

Element set		2, 3, 4, 6
Strainer screen	SMC32 (3 off)	5
Strainer screen and gasket	SMP32Y (1 off)	5, 11
Set of cover gaskets	(packet of 3)	7
Strainer cap gasket	(packet of 3)	11

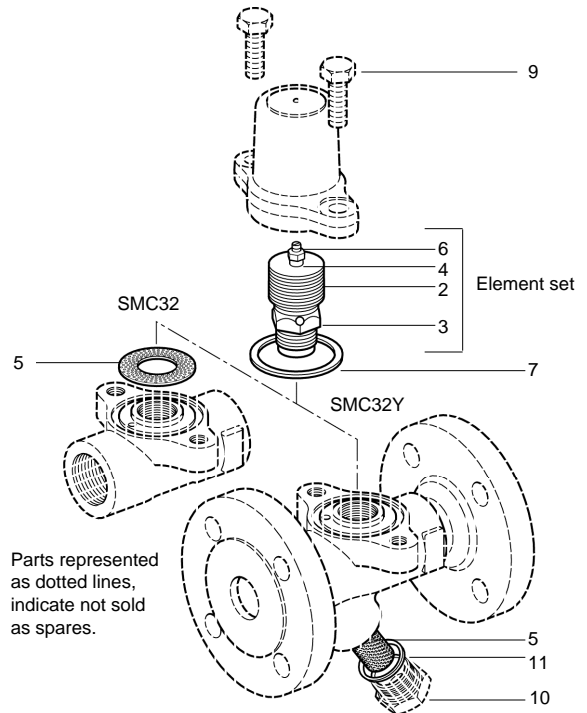

Parts represented as dotted lines, indicate not sold as spares.

Recommended tightening torques

Item	Part	mm	FT/LB
3	Valve seat	24 A/F	85 - 92
9	Cover bolts	17 A/F M10 x 30	17 - 20
10	Strainer cap	27 A/F	89 - 100