

spirax sarco®

SPIRA-tec® Remote Test Point R1 and R12

The SPIRA-tec® Trap Leak Detection System is designed to indicate whether a steam trap is leaking steam. A Plug Tail is fixed permanently into the sensor chamber, and this is then wired to the remote test point sited at any convenient point. Trap checking is then carried out by plugging into the remote test point rather than into the sensor chamber.

Available Types

R1 test point, suitable for one sensor chamber.
R12 test point has a selection switch which can be used for checking up to 12 sensor chambers.
The plug tail is supplied with 4 feet (1.25 m) of wire. Any additional wire must be provided by the installer in accordance with the Installation and Operating Instructions.
PT 1 plug tail is available with plug in connection
PT 2 plug tail is available with screw on connection and brass angle pattern housing.
PT 3 plug tail is available with screw on connection and brass angle pattern housing.
(PT 2 & PT 3 provide protection to IP67.)
Removing nut #1 allows a conduit adaptor to be connected to the M16 conduit thread on the housing, if cable protection is required.

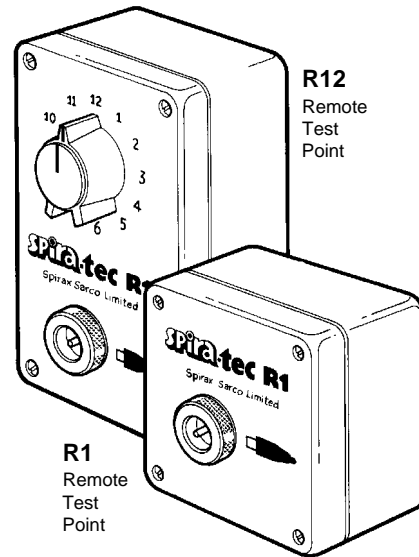

R1 *
Maximum Ambient
Temperature
176°F (80°C)

R12
Maximum Ambient
Temperature
120°F (49°C)

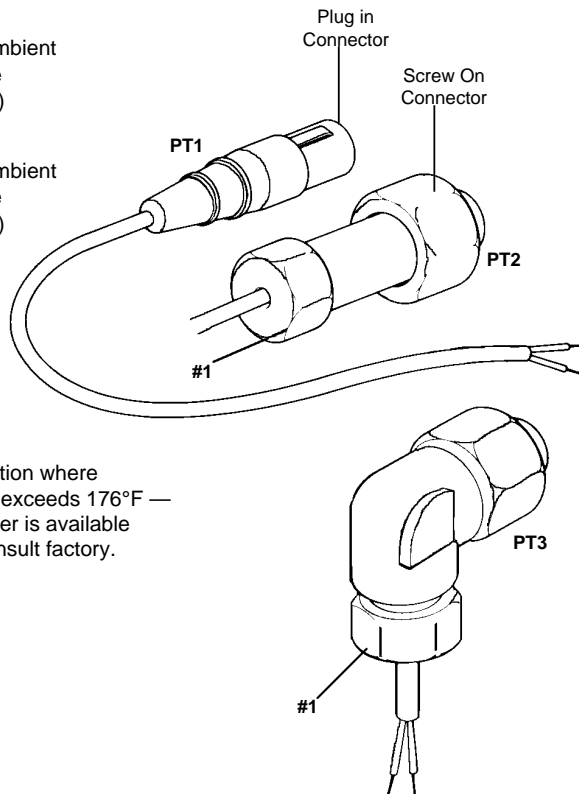

* For application where temperature exceeds 176°F — metal enclosure is available (R1 only) consult factory.

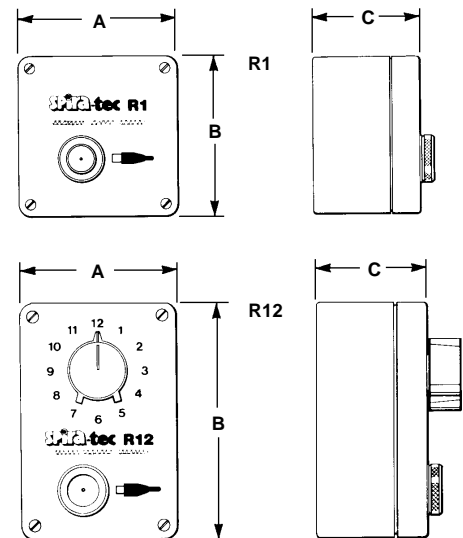

Dimensions (nominal) in inches and millimeters				
Type	A	B	C	Weight
R1	3.2 82	3.1 80	2.1 55	0.4 lb 0.2 kg
R12	3.1 80	4.7 120	2.1 65	0.7 lb 0.3 kg

SPIRA-tec® Remote Test Point R1 and R12

Use in Hazardous Areas

The Type 30 Indicator is listed by Underwriters Laboratories, Inc., as intrinsically safe for use in hazardous locations (Class 1, Division 1 & 2, Groups A, B, C & D, in accordance with U.L. Standard 913) when used with the ST Sensor Chamber, R1 and R12 remote test points.

The R1 and R2 are also approved for use in hazardous locations by BASEEFA under BS 5501, Parts 1 & 7. The enclosure is rated to IP 20 under BS5490. 1977.

Permissible Interconnecting Cables

The total Capacitance, Inductance and Inductance to Resistance (L/R) ratio of cables used in hazardous areas, must not exceed the following values:

Group	Capacitance in mF	Inductance in mH	or L/R ratio in mH/ohm
II C	0.3	0.22	19
IIB	0.9	0.66	57
II A	2.4	1.76	152

Installation

1. Decide on the most convenient cable entry. Remove the front cover by taking out the four securing screws and drill the required hole in the side or back of the test point. Fit a suitable waterproof cable entry. (Fig. 1) Note: The R1 cover will only fit one way round.
2. Secure the test point to a flat surface using the four mounting holes outside the sealed enclosure.
3. Connect the Plug Tail PT1, PT2, or PT3 into the pipeline sensor chamber. Extend the 4-ft (1.25 m) of cable provided by connecting on a suitable length of twin core cable. The type of cable is not critical – lightweight wire with 20 gauge conductors or 7/0.2 multi-strand wire will suffice. Similarly, the type of connection is not critical, but it should be made waterproof if exposed to moisture. The extension cable should be passed through the cable entry (Fig 2).
4. In the case of the R1, connect the extension to the terminals inside the cover.
5. In the case of the R12, connect the extension from all red or green wires to the numbered terminals on the edge connector, noting the number of each sensor. The test sheet provided can be used for this purpose. Extensions from all the blue wires should be connected to the square ground bar in the base of the box. With screw heads facing outwards, push the edge connector onto the printed circuit board (Fig. 3).
6. Replace the front cover and the four securing screws.

To Operate

Plug the indicator cable into the socket provided and use the indicator in accordance with its instructions.

In the case of the R12, the rotary switch should be used to select the sensor to be checked.

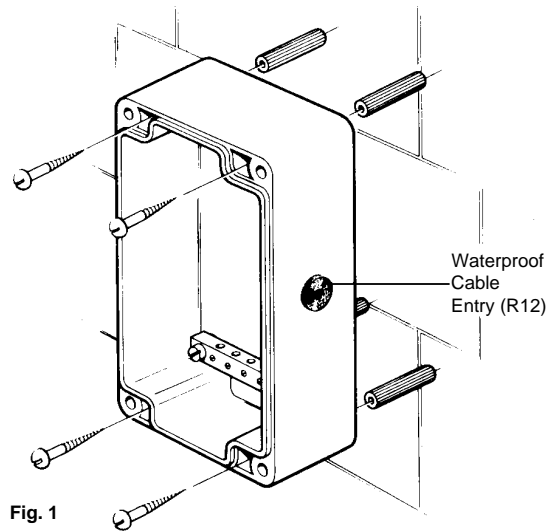

Fig. 1

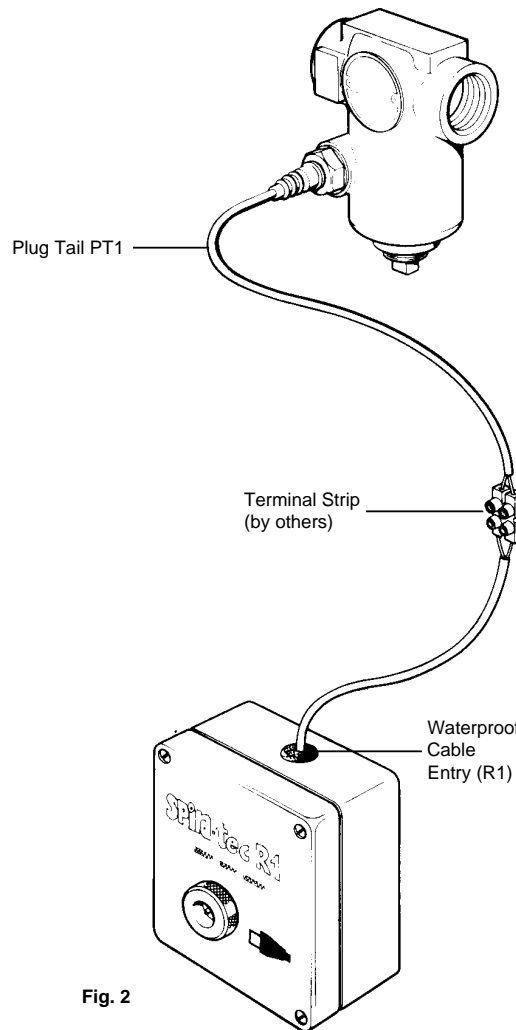

Fig. 2

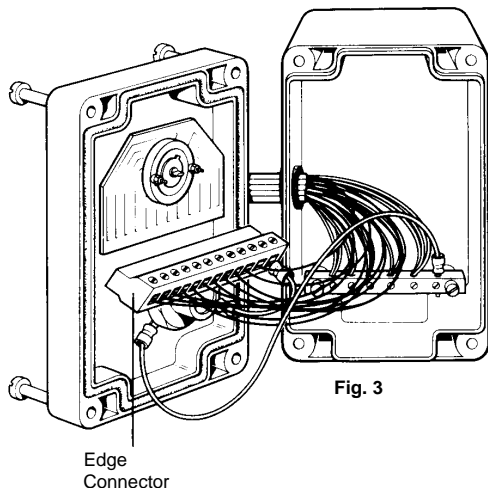

Fig. 3

Edge
Connector