

# ALOYCO

## Corrosion Resistant Valves



**THE FIRST NAME IN CORROSION RESISTANT VALVES**

**CRANE**  
THE VALVE EXPERTS

# Stainless Steel Valves

## General Index

Figure No.	Valve Type	Pressure Class	End Connection	Material Available	Size Range	Catalog Page
90	Gate, RS	200 CWP	Threaded	CF8M	½" - 2"	5
190	Gate, NRS	200 CWP	Threaded	CF8M	½" - 2"	5
110	Gate, OS&Y	150	Threaded	CF3M	½" - 2"	6
114	Gate, OS&Y	150	Socket Weld	CF3M	½" - 2"	6
117, 117F	Gate, OS&Y	150	Flanged	CF8M	½" - 24"	7
2110	Gate, OS&Y	300	Threaded	CF3M	½" - 2"	8
2114	Gate, OS&Y	300	Socket Weld	CF3M	½" - 2"	8
2117, 2117F	Gate, OS&Y	300	Flanged	CF8M	½" - 24"	9
4210	Gate, OS&Y	600	Threaded	CF3M	½" - 2"	10
4214	Gate, OS&Y	600	Socket Weld	CF3M	½" - 2"	10
4217, 4117F	Gate, OS&Y	600	Flanged	CF8M	½" - 24"	11
40	Globe	200 CWP	Threaded	CF8M	½" - 2"	12
310	Globe	150	Threaded	CF3M	½" - 2"	13
314	Globe	150	Socket Weld	CF3M	½" - 2"	13
317	Globe	150	Flanged	CF8M	½" - 12"	14
2310	Globe	300	Threaded	CF3M	½" - 2"	15
2314	Globe	300	Socket Weld	CF3M	½" - 2"	15
2317	Globe	300	Flanged	CF8M	½" - 8"	16
4310	Globe	600	Threaded	CF3M	½" - 2"	17
4314	Globe	600	Socket Weld	CF3M	½" - 2"	17
4317	Globe	600	Flanged	CF8M	½" - 6"	18
49	Swing Check	200 CWP	Threaded	CF8M	½" - 2"	19
370	Swing Check	150	Threaded	CF3M	½" - 2"	20
374	Swing Check	150	Socket Weld	CF3M	½" - 2"	20
377	Swing Check	150	Flanged	CF8M	½" - 24"	21
2370	Swing Check	300	Threaded	CF3M	½" - 2"	22
2374	Swing Check	300	Socket Weld	CF3M	½" - 2"	22
2377	Swing Check	300	Flanged	CF8M	½" - 24"	23
4370	Swing Check	600	Threaded	CF3M	½" - 2"	24
4374	Swing Check	600	Socket Weld	CF3M	½" - 2"	24
4377	Swing Check	600	Flanged	CF8M	½" - 12"	25
9502	Ball - 2 pc	2000/1500 CWP	Threaded	CF3M	¼" - 2"	26

# Stainless Steel Valves

## How To Order

### How to Specify and Order the Correct Valves

This catalog has been published to assist you in choosing the correct valve for a vast number of piping conditions. The Aloyco product line makes available to you a very broad choice of valves. These valves are described in this catalog.

Care should be taken to select the most suitable valves for your service(s). Exact specification of each valve should be made to avoid possible ambiguity. When requesting quotations and/or ordering the product a fully adequate description should be made.

### Selecting the Valve Size

Nominal size of the pipeline into which the valve will be placed must be determined.

### Valve Material

The following facts should be considered in determining the correct valve material:

- the medium or media which will be controlled
- the temperature range of the line medium (media)
- the pressure range to which the valve will be subjected
- possible atmospheric conditions which may affect the valve
- possible extraordinary stresses to which the valve will be subjected
- safety standards and/or piping codes which must be met

### Type of Valve

What is the control function of the valve? Each valve configuration has been developed to perform certain control functions. Do not expect one type of valve to perform all the valving jobs in a system.

### Pressure-Temperature Ratings

Please pay careful attention that the pressure-temperature ratings of a particular valve are in keeping with the requirements of the service. Pay especially careful attention to the packing and gasket materials as this may limit the rating as is the case with PTFE used as the standard in Aloyco valves. Specify alternative packing and/or gasket materials as necessary to meet or exceed your service requirements.

### Valve and Connections

Considerations as to pipeline integrity, future maintenance, corrosion factors, field assembly, weight and safety should be given in determining the method of connecting the valve in the pipeline.

### Method of Operation

The means by which the valve is operated as supplied are shown for the valves in this catalog. Many optional operating devices are regularly supplied by Aloyco.

### Ordering the Valve

Please state the following information when ordering a valve in order to avoid unnecessary delays and to insure we supply you with the valve you have requested.

1. Valve size
2. Pressure boundary material - metallurgy of the castings and components.
3. Type of valve - gate, globe, check, etc.
4. End connection including wall thickness of connecting pipe if weld end and any special flange facings or finishes
5. Any material deviations from standard - packing, gasket, bolting, etc.
6. Any accessories - acid shield, locking devices, chain operation, etc.
7. Manual or power actuators, please include details of requirements.
8. For convenience in ordering, specify by figure number.

Contact Aloyco for additional assistance in valve selection.

# Stainless Steel Gate Valves

**200 CWP • Threaded Bonnet • Solid Wedge Disc**

## Figure 90

Rising Stem

## Figure 190

Non-Rising Stem

### Size Range:

1/2 through 2 inches

### Design Features:

- Threaded Ends
- Integral Seat
- Figure 190 - Inside Screw/Non-rising Stem

### Pressure Temperature Ratings:

200 psi @ -20 to 100°F

135 psi @ 500°F

### Industry Standards

Threaded Ends	ASME B1.20.1
End-to-End	Manufacturer's Standard

### Materials of Construction

1	Body	ASTM A351 CF8M
2	Bonnet	ASTM A351 CF8M
3	Disc	ASTM A351 CF8M
4	Stem	316 SS
5	Packing	PTFE
6	Gland	316 SS
7	Gland Nut	ASTM A351 CF8M
8	Packing Washer	316 SS
9	Gasket	PTFE
10	Handwheel	ASTM A536
11	Handwheel Nut	304 SS
12	ID Tag	Aluminum

### Dimensions and Weights

Valve Size	Weight (lbs)		Dimensions (inches)					
			A		B (open)		C	
	90	190	90	190	90	190	90	190
1/2	1.0	0.9	2.01	2.1	5.1	3.8	2.6	2.1
3/4	1.3	1.5	2.20	2.3	5.8	4.6	2.6	2.6
1	1.7	2.5	2.48	2.8	6.6	5.3	3.0	2.8
1 1/2	3.4	3.2	3.01	3.6	9.4	7.3	3.6	3.6
2	5.2	7.0	3.41	3.9	11.0	8.4	4.0	4.1

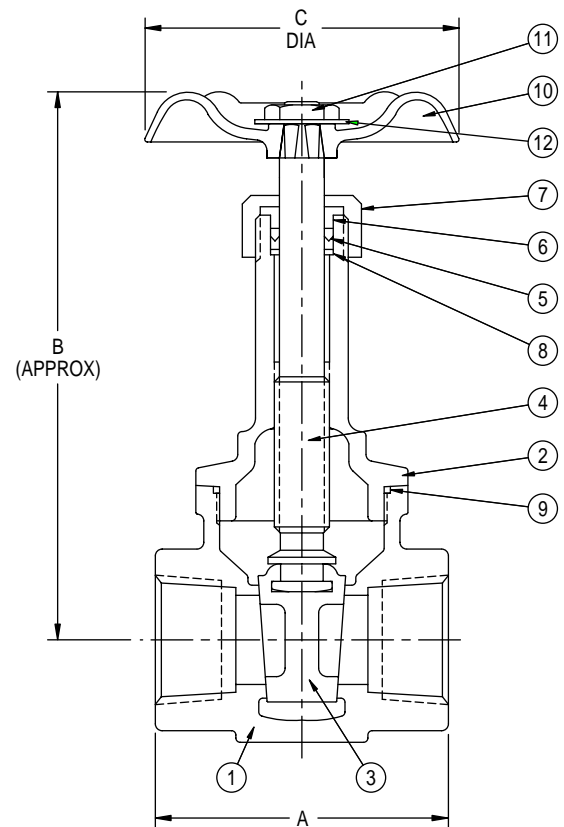

**Fig. 90**

## Class 150 • O S & Y • Solid Wedge Disc

### Figure 110

Threaded Ends

### Figure 114

Socket Weld Ends

#### Size Range:

1/2 through 2 inches

#### Design Features:

- Bolted Bonnet
- Rising Stem
- Integral Seat
- Retained Gasket
- MSS-SP-42
- API 603 (except for end connections)

#### Industry Standards

Pipe Threads	ASME B1.20.1
Wall Section	ASME B16.34
Socket Weld Ends	ASME B16.11
End-to-End	Manufacturer's Standard
Pressure-Temp Rating	ASME B16.34
Testing	API 598

#### Materials of Construction

1	Body	ASTM A351 CF3M
2	Bonnet	ASTM A351 CF8M
3	Disc	ASTM A351 CF8M
4	Stem	ASTM A276 T316
5	Handwheel	ASTM A536
6	Gasket	PTFE
7	Gland Flange	ASTM A351 CF8
8	Gland	ASTM A276 T304
9	Packing	PTFE
10	Stem Nut	ASTM A536
11	Handwheel Nut	ASTM A276 T304
12	Bonnet Bolt Nut	ASTM A194 GR 8
13	Bonnet Bolt	ASTM A193 GR B8
14	Eyebolt Pin	ASTM A276 T304
15	Eyebolt	ASTM A193 GR B8
16	Eyebolt Nut	ASTM A194 GR 8
17	ID Tag	Aluminum
18	Washer	ASTM A536
19	Grease Fitting	304 SS
20	Set Screw	Steel

#### Dimensions and Weights

Valve Size	Weight (lbs)	Dimensions (inches)			
		A	B (open)	C	D*
1/2	6.8	2.76	8.1	3.9	.38
3/4	7.2	3.15	8.5	3.9	.50
1	9.8	3.54	9.1	3.9	.50
1 1/2	14.9	4.13	11.0	5.5	.50
2	20.1	4.72	12.6	6.3	.62

\*For Figure 114 only - Socket weld depth

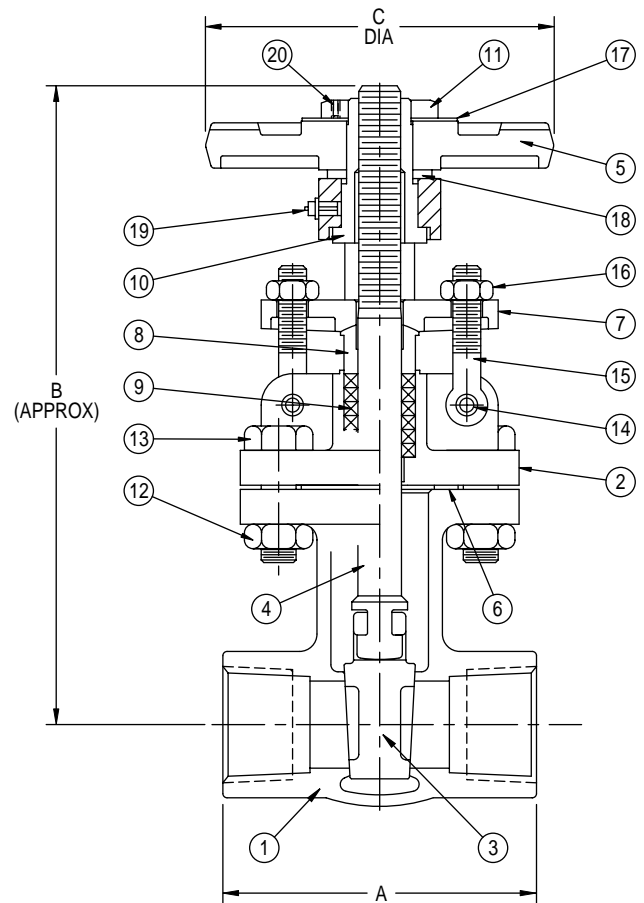

**Fig. 110**

# Stainless Steel Gate Valves

## Class 150 • O S & Y • Solid or Flexible Wedge Disc

Figure 117

Raised Face, Flanged Ends, Solid Wedge Disc

Figure 117F

Raised Face, Flanged Ends, Flexible Wedge Disc

**Size Range:**

1/2 through 24 inches

**Design Features:**

- Bolted Bonnet
- Rising Stem
- Integral Seat
- Retained Gasket
- MSS SP-42
- API 603

**Industry Standards**

End Flanges	ASME B16.5
Wall Section	ASME B16.34
Face-to-Face	ASME B16.10
Pressure-Temp Ratings	ASME B16.34
Design	API 603
Testing	API 598

**Materials of Construction**

1	Body	ASTM A351 CF8M
2	Bonnet	ASTM A351 CF8M
3	Disc	ASTM A351 CF8M
4	Stem	ASTM A276 T316
5	Handwheel	ASTM A536
6	Gasket	PTFE
7	Gland Flange	ASTM A351 CF8
8	Gland	ASTM A276 T304
9	Packing	PTFE
10	Stem Nut	ASTM A536
11	Handwheel Nut	ASTM A276 T304
12	Bonnet Bolt Nut	ASTM A194 GR 8
13	Bonnet Bolt	ASTM A193 GR B8
14	Eyebolt Pin	ASTM A276 T304
15	Eyebolt	ASTM A193 GR B8
16	Eyebolt Nut	ASTM A194 GR 8
17	ID Tag	Aluminum
18	Washer	ASTM A536
19	Grease Fitting	304 SS
20	Set Screw	Steel

**Dimensions and Weights**

Valve Size	Weight (lbs)	Dimensions (inches)		
		A	B (open)	C
1/2	7.4	4.25	8.1	3.9
3/4	8.3	4.63	8.5	3.9
1	10.0	5.00	9.1	3.9
1 1/2	18.0	6.50	11.0	5.5
2	27.0	7.00	12.6	6.3
2 1/2	37.5	7.50	15.1	6.3
3	46.3	8.00	16.7	7.9
4	75.0	9.00	20.9	9.8
6	128.0	10.50	28.7	12.4
8	216.1	11.50	36.9	14.0
10	291.1	13.00	43.9	14.0
12	436.6	14.00	51.9	15.7
14	703.4	15.00	58.5	17.7
16	1018.7	16.00	66.9	19.7
18	1190.7	17.00	74.8	22.0
20	1631.7	18.00	82.5	28.0
24	2434.3	20.00	97.4	31.5

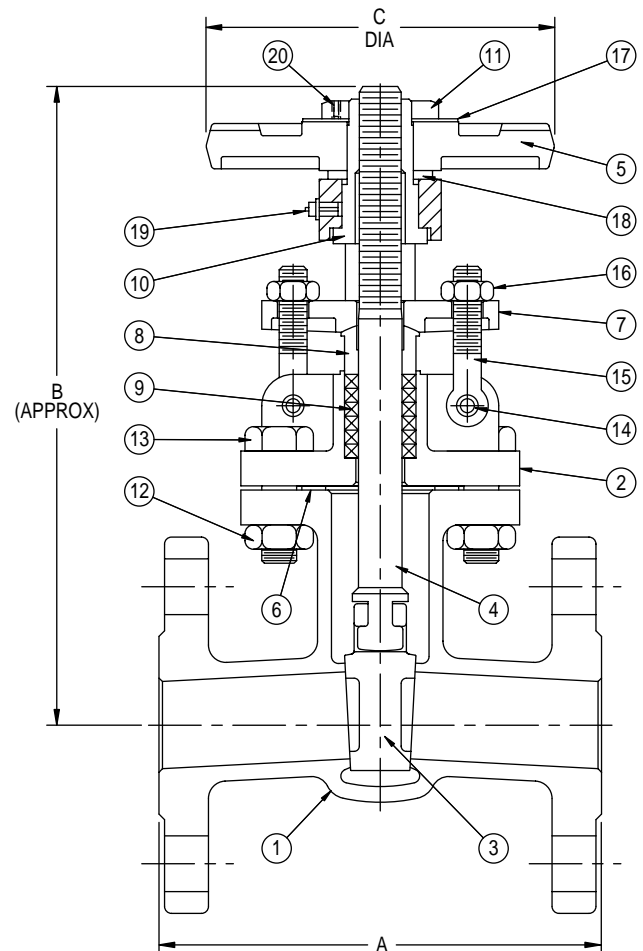

Fig. 117

## Class 300 • O S & Y • Solid Wedge Disc

### Figure 2110

Threaded Ends

### Figure 2114

Socket Weld Ends

#### Size Range:

1/2 through 2 inches

#### Design Features:

- Bolted Bonnet
- Retained Gasket
- Rising Stem
- Integral Seat
- MSS-SP-42
- ASME B16.34

#### Industry Standards

Pipe Threads	ASME B1.20.1
Wall Section	ASME B16.34
Socket Weld Ends	ASME B16.11
End-to-End	Manufacturer's Standard
Pressure-Temp. Rating	ASME B16.34
Testing	API 598

#### Materials of Construction

1	Body	ASTM A351 CF3M
2	Bonnet	ASTM A351 CF8M
3	Disc	ASTM A351 CF8M
4	Stem	ASTM A276 T316
5	Handwheel	ASTM A536
6	Gasket	PTFE
7	Gland Flange	ASTM A351 CF8
8	Gland	ASTM A276 T304
9	Packing	PTFE
10	Stem Nut	ASTM A536
11	Handwheel Nut	ASTM A276 T304
12	Bonnet Bolt Nut	ASTM A194 GR 8
13	Bonnet Bolt	ASTM A193 GR B8
14	Eyebolt Pin	ASTM A276 T304
15	Eyebolt	ASTM A193 GR B8
16	Eyebolt Nut	ASTM A194 GR 8
17	ID Tag	Aluminum
18	Washer	ASTM A536
19	Grease Fitting	304 SS
20	Set Screw	Steel

#### Dimensions and Weights

Valve Size	Weight (lbs)	Dimensions (inches)			
		A	B (open)	C	D*
1/2	6.8	3.23	8.1	3.9	.38
3/4	7.0	3.23	8.1	3.9	.50
1	10.7	4.13	9.9	5.4	.50
1 1/2	19.5	4.92	12.0	7.9	.50
2	23.5	5.31	13.4	7.9	.62

\*For Figure 2114 only - Socket weld depth

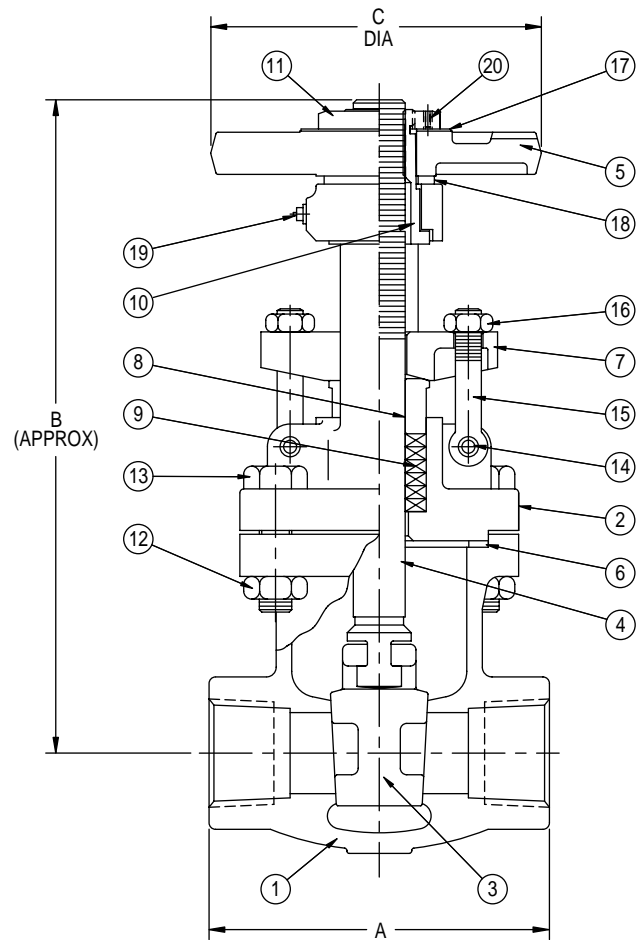

**Fig. 2110**



# Stainless Steel Gate Valves

FIGURES  
2117 • 2117F

## Class 300 • O S & Y • Solid or Flexible Wedge Disc

### Figure 2117

Raised Face, Flanged Ends, Solid Wedge Disc

### Figure 2117F

Raised Face, Flanged Ends, Flexible Wedge Disc

#### Size Range:

1/2 through 24 inches

#### Design Features:

- Bolted Bonnet
- Retained Gasket
- Rising Stem
- Integral Seat
- MSS-SP-42
- ASME B16.34

#### Industry Standards

End Flanges	ASME B16.5
Wall Section	ASME B16.34
Face-to-Face	ASME B16.10
Pressure-Temp. Ratings	ASME B16.34
Testing	API 598

#### Materials of Construction

1	Body	ASTM A351 CF8M
2	Bonnet	ASTM A351 CF8M
3	Disc	ASTM A351 CF8M
4	Stem	ASTM A276 T316
5	Handwheel	ASTM A536
6	Gasket	PTFE
7	Gland Flange	ASTM A351 CF8
8	Gland	ASTM A276 T304
9	Packing	PTFE
10	Stem Nut	ASTM A536
11	Handwheel Nut	ASTM A276 T304
12	Bonnet Bolt Nut	ASTM A194 GR 8
13	Bonnet Bolt	ASTM A193 GR B8
14	Eyebolt Pin	ASTM A276 T304
15	Eyebolt	ASTM A193 GR B8
16	Eyebolt Nut	ASTM A194 GR 8
17	ID Tag	Aluminum
18	Washer	ASTM A536
19	Grease Fitting	304 SS
20	Set Screw	Steel

#### Dimensions and Weights

Valve Size	Weight (lbs)	Dimensions (inches)		
		A	B (open)	C
1/2	--	5.50	8.1	3.9
3/4	--	6.00	8.1	3.9
1	--	6.50	9.9	5.4
1 1/2	--	7.50	12.0	7.9
2	--	8.50	13.4	7.9
2 1/2	68.4	9.50	17.0	7.9
3	90.4	11.12	19.3	8.8
4	119.1	12.00	23.1	9.8
6	251.4	15.88	31.6	14.0
8	478.5	16.50	39.4	15.7
10	557.9	18.00	47.9	17.7
12	917.3	19.75	55.8	19.7
14	957.0	30.00	59.8	22.0
16	1206.1	33.00	66.7	24.8
18	1764.0	36.00	75.2	28.0
20	3281.0	39.00	83.4	31.5
24	4956.8	45.00	98.1	35.4

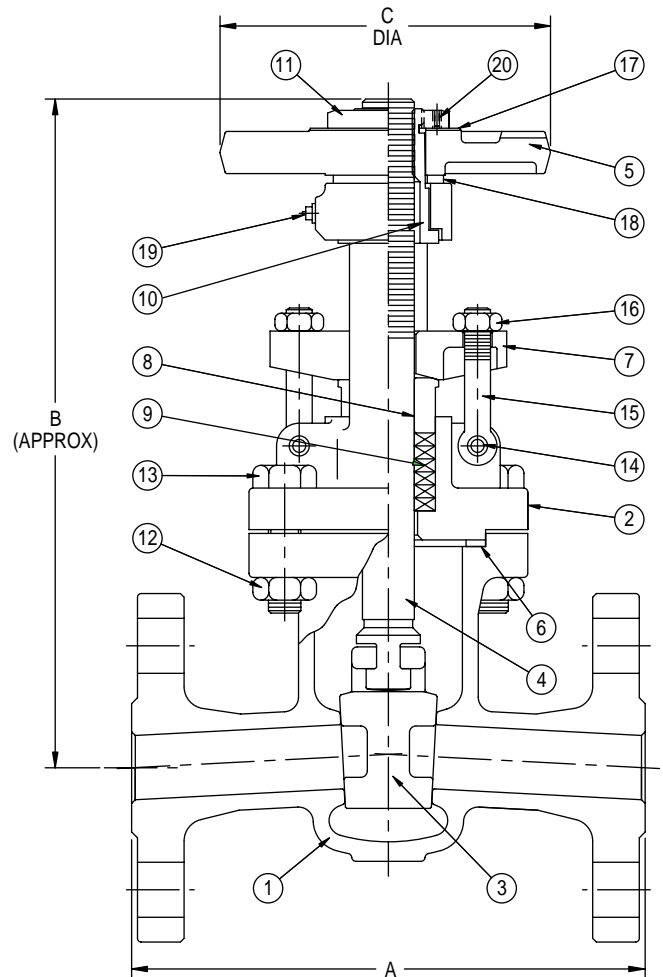

Fig. 2117





## Class 600 • O S & Y • Solid Wedge Disc

### Figure 4210

Threaded Ends

### Figure 4214

Socket Weld Ends

#### Size Range:

1/2 through 2 inches

#### Design Features:

- Bolted Bonnet
- Retained Gasket
- Rising Stem
- Integral Seat
- ASME B16.34

#### Industry Standards

Pipe Threads	ASME B1.20.1
Wall Section	ASME B16.34
Socket Weld Ends	ASME B16.11
End-to-End	Manufacturer's Standards
Pressure-Temp Rating	ASME B16.34
Testing	API 598

#### Materials of Construction

1	Body	ASTM A351 CF3M
2	Bonnet	ASTM A351 CF8M
3	Disc	ASTM A351 CF8M
4	Stem	ASTM A351 CF8M
5	Handwheel	ASTM A536
6	Gasket	PTFE
7	Gland Flange	ASTM A351 CF8
8	Gland	ASTM A276 T304
9	Packing	PTFE
10	Stem Nut	ASTM A536
11	Handwheel Nut	ASTM A276 T304
12	Bonnet Bolt Nut	ASTM A194 GR 8
13	Bonnet Bolt	ASTM A193 GR B8
14	Eyebolt Pin	ASTM A276 T304
15	Eyebolt	ASTM A193 GR B8
16	Eyebolt Nut	ASTM A194 GR 8
17	ID Tag	Aluminum
18	Washer	ASTM A536
19	Grease Fitting	304 SS
20	Set Screw	Steel

#### Dimensions and Weights

Valve Size	Weight (lbs)	Dimensions (inches)			
		A	B (open)	C	D*
1/2	6.8	3.23	8.1	3.9	.38
3/4	7.0	3.23	8.1	3.9	.50
1	10.7	4.13	9.9	5.4	.50
1 1/2	19.5	4.92	12.0	7.9	.50
2	23.5	5.31	13.4	7.9	.62

\*For Figure 4214 only - Socket weld depth

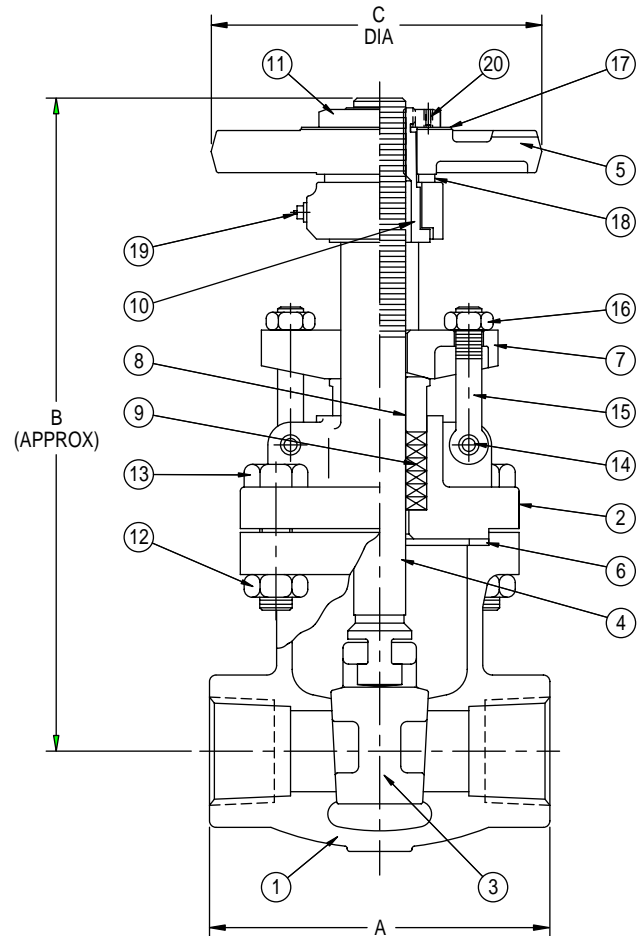

**Fig. 4210**

# Stainless Steel Gate Valves

FIGURES  
4217 • 4117F

## Class 600 • O S & Y • Solid or Flexible Wedge Disc

### Figure 4217

1/2 to 2 inches, Raised Face, Flanged Ends

### Figure 4117F

2 1/2 to 24 inches, Raised Face, Flanged Ends

#### Size Range:

1/2 through 24 inches

#### Design Features:

- Bolted Bonnet
- Inside Screw
- Rising Stem
- Integral Seat
- Tested to API 598
- ASME B16.34

#### Industry Standards

End Flanges	ASME B16.5
Wall Section	ASME B16.34
Face-to-Face	ASME B16.10
Pressure-Temp. Ratings	ASME B16.34
Testing	API 598

#### Materials of Construction

1	Body	ASTM A351 CF8M
2	Bonnet	ASTM A351 CF8M
3	Disc	ASTM A351 CF8M
4	Stem	ASTM A276 T316
5	Handwheel	ASTM A536
6	Gasket	PTFE
7	Gland Flange	ASTM A351 CF8
8	Gland	ASTM A276 T304
9	Packing	PTFE
10	Stem Nut	ASTM A536
11	Handwheel Nut	ASTM A276 T304
12	Bonnet Bolt Nut	ASTM A194 GR 8
13	Bonnet Bolt	ASTM A193 GR B8
14	Eyebolt Pin	ASTM A276 T304
15	Eyebolt	ASTM A193 GR B8
16	Eyebolt Nut	ASTM A194 GR 8
17	ID Tag	Aluminum
18	Washer	ASTM A536
19	Grease Fitting	304 SS
20	Set Screw	Steel

#### Dimensions and Weights

Valve Size	Weight (lbs)	Dimensions (inches)		
		A	B (open)	C
1/2	---	6.50	8.1	3.9
3/4	---	7.50	8.1	3.9
1	---	8.50	9.9	5.4
1 1/2	---	9.50	12.0	7.9
2	---	11.50	13.4	7.9
2 1/2	111.8	13.00	18.0	8.8
3	145.9	14.00	20.1	9.8
4	277.1	17.00	25.0	14.0
6	534.8	22.00	37.7	17.7
8	938.4	26.00	42.4	19.7
10	1390.5	31.00	48.9	24.8
12	1993.4	33.00	56.7	28.0
14	2669.3	35.00	64.1	31.5
16	3121.4	39.00	71.1	35.4
18	4915.5	43.00	78.1	35.4
20	6223.4	47.00	89.9	43.0
24	8693.3	55.00	107.0	43.0

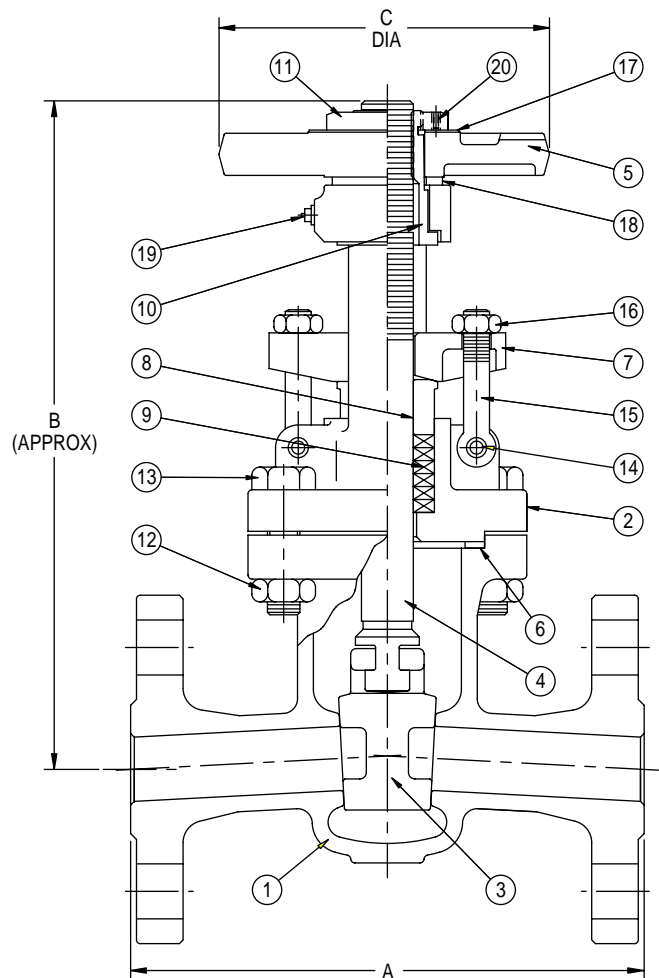

Fig. 4217



# FIGURE 40

# Stainless Steel Globe Valves

## 200 CWP • Threaded Bonnet • Plug Type Disc

### Figure 40

Threaded Ends

#### Size Range:

1/2 through 2 inches

#### Design Features:

- Threaded Bonnet
- Inside Screw
- Rising Stem
- Integral Seat

#### Pressure Temperature Ratings:

200 psi @ -20° to 100°F

135 psi @ 500°F max.

#### Industry Standards

Threaded Ends	ASME B1.20.1
End-to-End	Manufacturer's Standard

#### Materials of Construction

1	Body	ASTM A351 CF8M
2	Bonnet	ASTM A351 CF8M
3	Disc	316 SS
4	Stem	316 SS
5	Disc Nut	316 SS
6	Disc Washer	316 SS
7	Packing	PTFE
8	Gland	316 SS
9	Gland Nut	316 SS
10	Packing Washer	316 SS
11	Gasket	PTFE
12	Handwheel	Ductile Iron
13	Handwheel Nut	304 SS
14	ID Tag	304 SS

### Dimensions and Weights

Valve Size	Weight (lbs)	Dimensions (inches)		
		A	B (open)	C
1/2	1.0	2.76	4.0	2.6
3/4	1.4	3.15	4.0	2.6
1	1.8	3.54	4.2	3.0
1 1/2	3.3	4.72	5.4	3.4
2	4.9	5.51	5.8	4.0

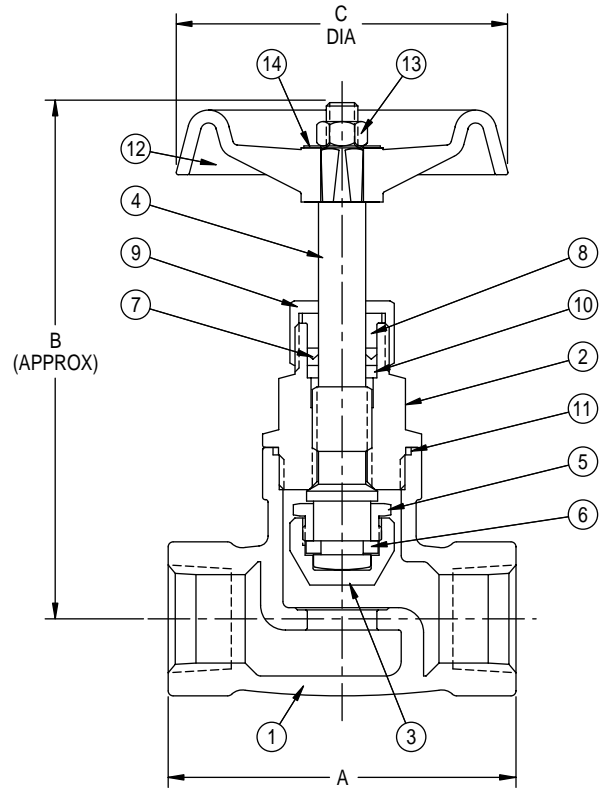

Fig. 40

# Stainless Steel Globe Valves

## Class 150 • O S & Y • Plug Type Disc

### Figure 310

Threaded Ends

### Figure 314

Socket Weld Ends

#### Size Range:

1/2 through 2 inches

#### Design Features:

- Bolted Bonnet
- Retained Gasket
- Rising Stem
- Integral Seat
- MSS-SP-42
- ASME B16.34

#### Industry Standards

Pipe Threads	ASME B1.20.1
Wall Section	ASME B16.34
Socket Weld Ends	ASME B16.11
End-to-End	Manufacturer's Standard
Pressure-Temp. Ratings	ASME B16.34
Testing	API 598

#### Materials of Construction

1	Body	ASTM A351 CF3M
2	Bonnet	ASTM A351 CF8M
3	Disc	ASTM A351 CF8M
4	Stem	ASTM A276 T316
5	Disc Nut	ASTM A276 T316
6	Handwheel	ASTM A536
7	Gasket	PTFE
8	Gland Flange	ASTM A351 CF8
9	Gland	ASTM A276 T304
10	Packing	PTFE
11	Stem Nut	ASTM A536
12	Handwheel Nut	ASTM A194 GR 8
13	Bonnet Bolt Nut	ASTM A194 GR 8
14	Bonnet Bolt	ASTM A193 GR B8
15	Eyebolt Pin	ASTM A276 T304
16	Eyebolt	ASTM A193 GR B8
17	Eyebolt Nut	ASTM A194 GR 8
18	ID Tag	Aluminum
19	Washer	ASTM A276 T304

#### Dimensions and Weights

Valve Size	Weight (lbs)	Dimensions (inches)			
		A	B (open)	C	D*
1/2	6.6	3.74	7.1	3.9	.38
3/4	6.9	4.53	7.3	3.9	.50
1	8.7	4.92	7.9	3.9	.50
1 1/2	12.6	5.52	9.2	5.5	.50
2	17.3	6.50	10.2	6.3	.31

\* For Figure 314 only - socket weld depth

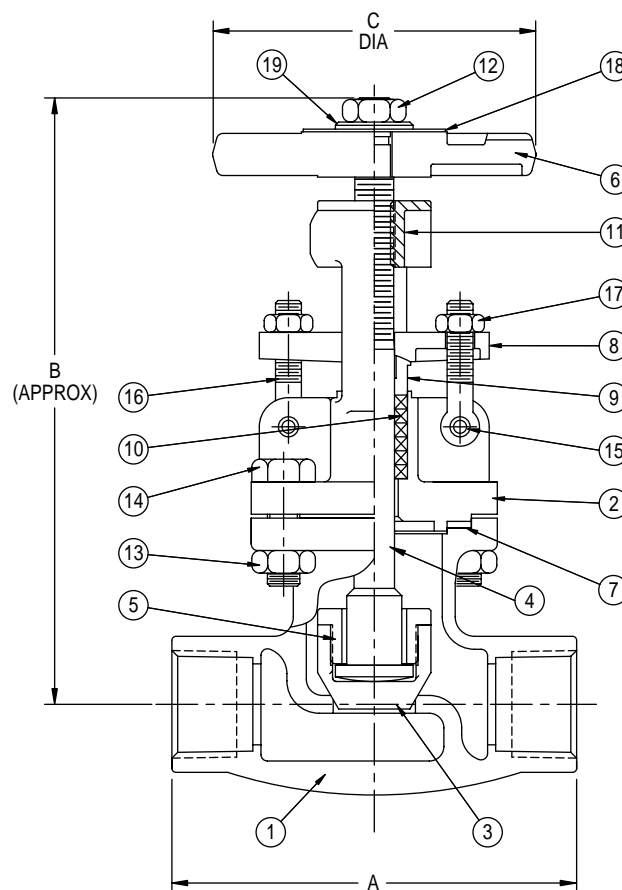

Fig. 310

# FIGURE 317

# Stainless Steel Globe Valves

## Class 150 • O S & Y • Plug Type Disc

### Figure 317

Raised Face, Flanged Ends

#### Size Range:

1/2 through 12 inches

#### Design Features:

- Bolted Bonnet
- Rising Stem
- Retained Gasket
- Integral Seat
- Disc Guide Below Seat
- MSS-SP-42
- ASME B16.34

#### Industry Standards

End Flanges	ASME B16.5
Wall Section	ASME B16.34
Face-to-Face	ASME B16.10
Pressure-Temp. Ratings	ASME B16.34
Testing	API 598

#### Materials of Construction

1	Body	ASTM A351 CF8M
2	Bonnet	ASTM A351 CF8M
3	Disc	ASTM A351 CF8M
4	Stem	ASTM A276 T316
5	Disc Nut	ASTM A276 T316
6	Handwheel	ASTM A536
7	Gasket	PTFE
8	Gland Flange	ASTM A351 CF8
9	Gland	ASTM A276 T304
10	Packing	PTFE
11	Stem Nut	ASTM A536
12	Handwheel Nut	ASTM A194 GR 8
13	Bonnet Bolt Nut	ASTM A194 GR 8
14	Bonnet Bolt	ASTM A193 GR B8
15	Eyebolt Pin	ASTM A276 T304
16	Eyebolt	ASTM A193 GR 8
17	Eyebolt Nut	ASTM A194 GR 8
18	ID Tag	Aluminum
19	Washer	ASTM A276 T304

#### Dimensions and Weights

Valve Size	Weight (lbs)	Dimensions (inches)		
		A	B (open)	C
1/2	7.6	4.25	7.1	3.9
3/4	8.9	4.63	7.3	3.9
1	11.6	5.00	7.9	3.9
1 1/2	16.4	6.50	9.2	5.5
2	25.2	8.00	10.2	6.3
2 1/2	46.3	8.50	11.1	7.9
3	61.7	9.50	13.5	8.8
4	97.0	11.50	14.8	11.0
6	198.5	16.00	16.9	14.0
8	383.7	19.50	22.0	14.0
10	546.8	24.50	29.7	15.7
12	848.9	27.50	32.5	15.7

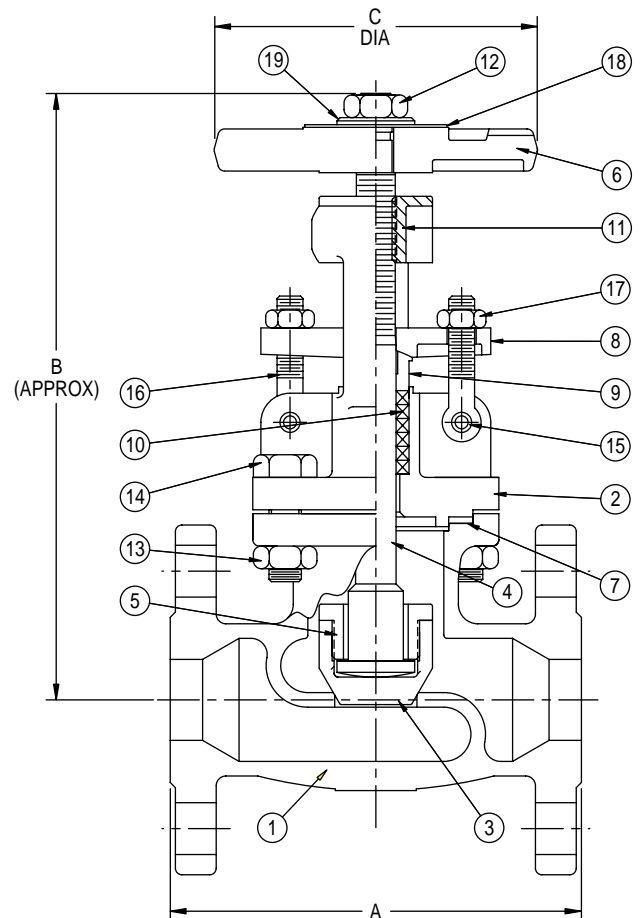

Fig. 317

# Stainless Steel Globe Valves

## Class 300 • O S & Y • Plug Type Disc

### Figure 2310

Threaded Ends

### Figure 2314

Socket Weld Ends

### Size Range:

1/2 through 2 inches

### Design Features:

- Bolted Bonnet
- Rising Stem
- Retained Gasket
- Integral Seat
- MSS-SP-42

### Industry Standards

Pipe Threads	ASME B1.20.1
Wall Section	ASME B16.34
Face-to-Face	Manufacturer's Standard
Pressure-Temp. Ratings	ASME B16.34
Socket Weld Ends	ASME B16.11
Testing	API 598

### Materials of Construction

1	Body	ASTM A351 CF3M
2	Bonnet	ASTM A351 CF8M
3	Disc	ASTM A351 CF8M
4	Stem	ASTM A276 T316
5	Handwheel	ASTM A536
6	Gasket	PTFE
7	Gland Flange	ASTM A351 CF8
8	Gland	ASTM A276 T304
9	Packing	PTFE
10	Stem Nut	ASTM A536
11	Handwheel Nut	ASTM A193 GR 8
12	Bonnet Bolt Nut	ASTM A194 GR 8
13	Bonnet Bolt	ASTM A193 GR B8
14	Eyebolt Pin	ASTM A276 T304
15	Eyebolt	ASTM A193 GR B8
16	Eyebolt Nut	ASTM A194 GR 8
17	ID Tag	Aluminum
18	Washer	304 SS
19	Stem Ring	ASTM A276 T316

### Dimensions and Weights

Valve Size	Weight (lbs)	Dimensions (inches)			
		A	B (open)	C	D*
1/2	7.0	3.23	7.8	3.9	.38
3/4	7.0	3.23	7.8	3.9	.50
1	10.3	4.13	9.0	3.9	.50
1 1/2	18.2	4.92	10.7	5.5	.50
2	22.6	5.91	11.3	6.3	.62

\* For Figure 2314 only - socket weld depth

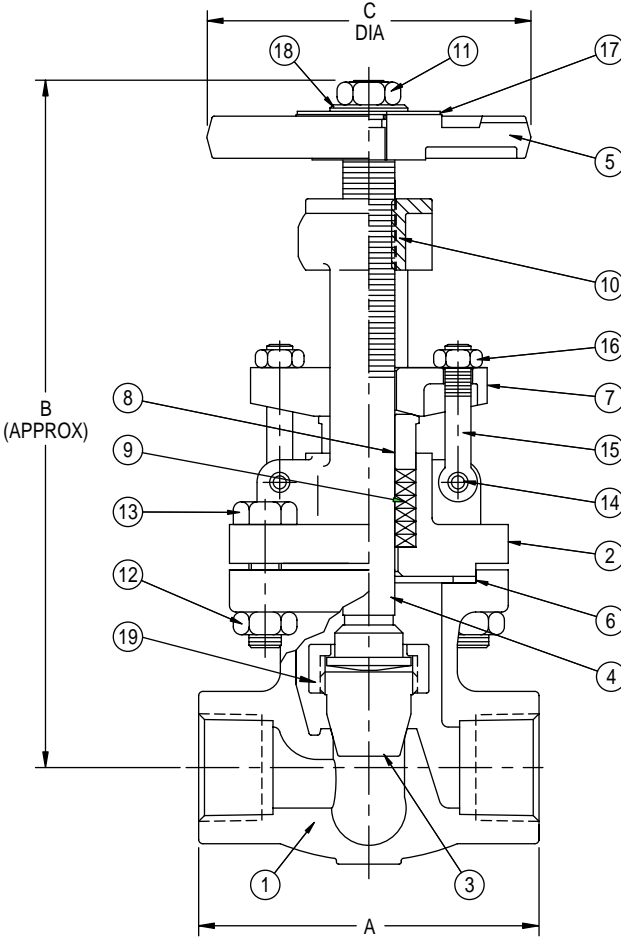

Fig. 2310

# FIGURE 2317

# Stainless Steel Globe Valves

## Class 300 • O S & Y • Plug Type Disc

### Figure 2317

Raised Face, Flanged Ends

#### Size Range:

1/2 through 8 inches

#### Design Features:

- Bolted Bonnet
- Retained Gasket
- Rising Stem, Rising Handwheel
- Integral Seat
- MSS-SP-42
- ASME B16.34

### Industry Standards

End Flanges	ASME B16.5
Wall Section	ASME B16.34
Face-to-Face	ASME B16.10
Pressure-Temp. Ratings	ASME B16.34
Testing	API 598

### Materials of Construction

1	Body	ASTM A351 CF8M
2	Bonnet	ASTM A351 CF8M
3	Disc	ASTM A351 CF8M
4	Stem	ASTM A276 T316
5	Handwheel	ASTM A536
6	Gasket	PTFE
7	Gland Flange	ASTM A351 CF8
8	Gland	ASTM A276 T304
9	Packing	PTFE
10	Stem Nut	ASTM A536
11	Handwheel Nut	ASTM A193 GR 8
12	Bonnet Bolt Nut	ASTM A194 GR 8
13	Bonnet Bolt	ASTM A193 GR B8
14	Eyebolt Pin	ASTM A276 T304
15	Eyebolt	ASTM A193 GR B8
16	Eyebolt Nut	ASTM A194 GR 8
17	ID Tag	Aluminum
18	Washer	304 SS
19	Stem Ring	ASTM A276 T316

### Dimensions and Weights

Valve Size	Weight (lbs)	Dimensions (inches)		
		A	B (open)	C
1/2	---	6.00	7.8	3.9
3/4	---	7.00	7.8	3.9
1	---	8.00	9.0	3.9
1 1/2	---	9.00	10.7	5.5
2	---	10.50	11.3	6.3
2 1/2	83.8	11.50	13.9	7.9
3	83.8	12.50	15.1	8.8
4	130.1	14.00	17.4	11.0
6	317.5	17.50	22.3	15.8
8	562.3	22.00	24.2	15.8

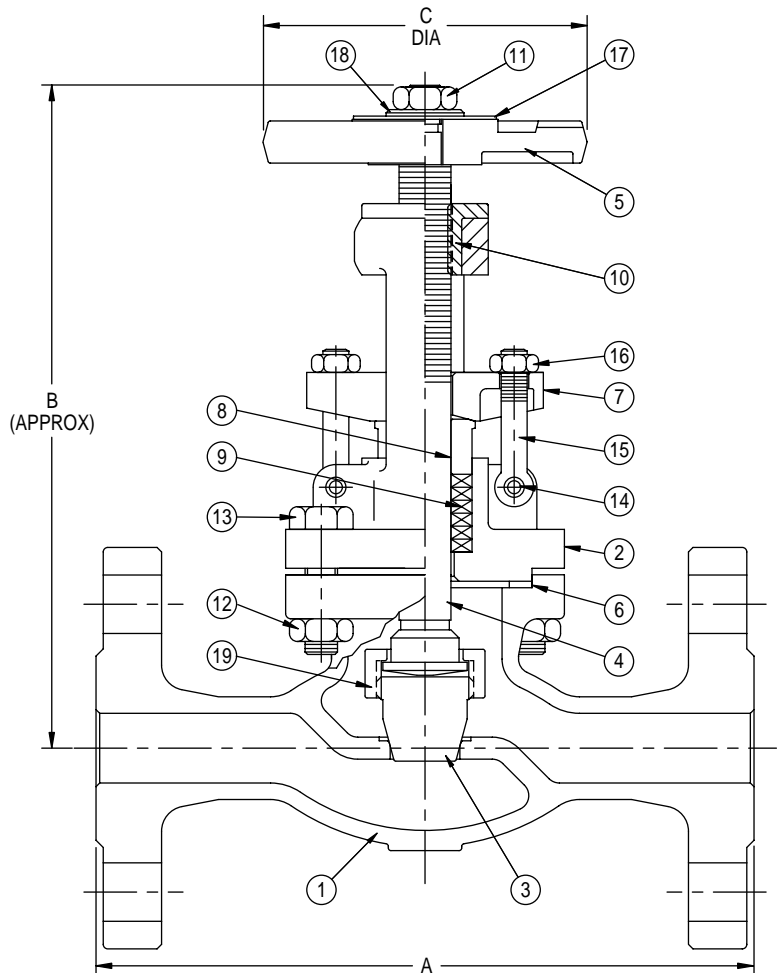

Fig. 2317



# Stainless Steel Globe Valves

## Class 600 • O S & Y • Plug Type Disc

### Figure 4310

Threaded Ends

### Figure 4314

Socket Weld Ends

#### Size Range:

1/2 through 2 inches

#### Design Features:

- Bolted Bonnet
- Rising Stem
- Retained Gasket
- Integral Seat
- MSS SP-42

#### Industry Standards

Pipe Threads	ASME B1.20.1
Wall Section	ASME B16.34
Face-to-Face	Manufacturer's Standard
Pressure-Temp. Ratings	ASME B16.34
Socket Weld Ends	ASME B16.11
Testing	API 598

#### Materials of Construction

1	Body	ASTM A351 CF3M
2	Bonnet	ASTM A351 CF8M
3	Disc	ASTM A351 CF8M
4	Stem	ASTM A276 T316
5	Handwheel	ASTM A536
6	Gasket	PTFE
7	Gland Flange	ASTM A351 CF8
8	Gland	ASTM A276 T304
9	Packing	PTFE
10	Stem Nut	ASTM A536
11	Handwheel Nut	ASTM A193 GR 8
12	Bonnet Bolt Nut	ASTM A194 GR 8
13	Bonnet Bolt	ASTM A193 GR B8
14	Eyebolt Pin	ASTM A276 T304
15	Eyebolt	ASTM A193 GR B8
16	Eyebolt Nut	ASTM A194 GR 8
17	ID Tag	Aluminum
18	Washer	304 SS
19	Stem Ring	ASTM A276 T316

#### Dimensions and Weights

Valve Size	Weight (lbs)	Dimensions (inches)			
		A	B (open)	C	D*
1/2	7.0	3.23	7.8	3.9	.38
3/4	7.0	3.23	7.8	3.9	.50
1	10.3	4.13	9.0	3.9	.50
1 1/2	18.2	4.92	10.7	5.5	.50
2	22.6	5.91	11.3	6.3	.62

\* For Figure 2314 only - socket weld depth

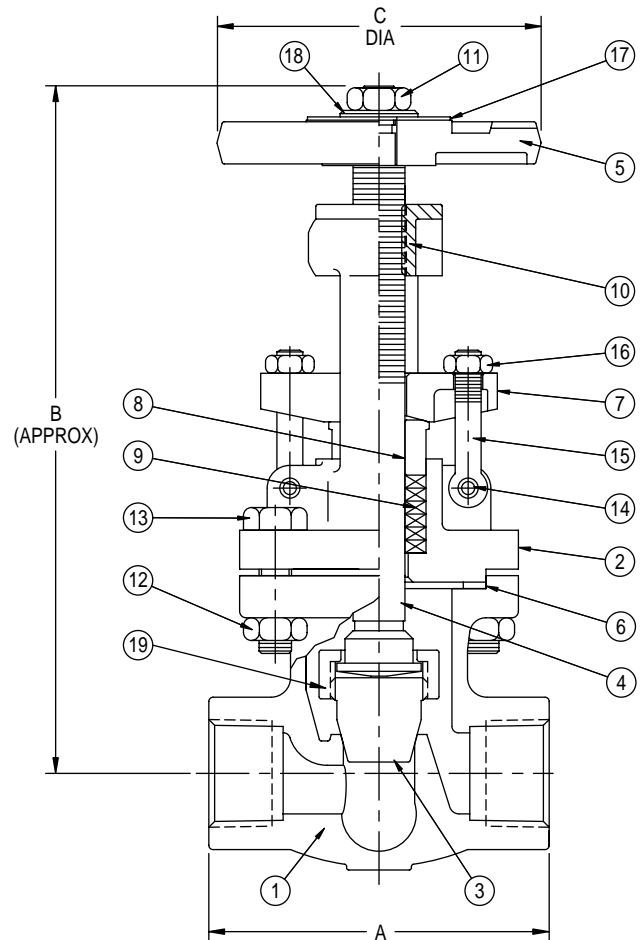

Fig. 4310

# FIGURE 4317

# Stainless Steel Globe Valves

## Class 600 • O S & Y • Plug Type Disc

### Figure 4317

Raised Face, Flanged Ends

#### Size Range:

1/2 through 6 inches

#### Design Features:

- Bolted Bonnet
- Retained Gasket
- Rising Stem, Rising Handwheel
- Integral Seat
- MSS SP-42
- ASME B16.34

### Industry Standards

End Flanges	ASME B16.5
Wall Section	ASME B16.34
Face-to-Face	ASME B16.10
Pressure-Temp. Ratings	ASME B16.34
Testing	API 598

### Materials of Construction

1	Body	ASTM A351 CF8M
2	Bonnet	ASTM A351 CF8M
3	Disc	ASTM A351 CF8M
4	Stem	ASTM A276 T316
5	Handwheel	ASTM A536
6	Gasket	PTFE
7	Gland Flange	ASTM A351 CF8
8	Gland	ASTM A276 T304
9	Packing	PTFE
10	Stem Nut	ASTM A536
11	Handwheel Nut	ASTM A193 GR 8
12	Bonnet Bolt Nut	ASTM A194 GR 8
13	Bonnet Bolt	ASTM A193 GR B8
14	Eyebolt Pin	ASTM A276 T304
15	Eyebolt	ASTM A193 GR B8
16	Eyebolt Nut	ASTM A194 GR 8
17	ID Tag	Aluminum
18	Washer	304 SS
19	Stem Ring	ASTM A276 T316

### Dimensions and Weights

Valve Size	Weight (lbs)	Dimensions (inches)		
		A	B (open)	C
1/2	---	6.50	7.8	3.9
3/4	---	7.50	7.8	3.9
1	---	8.50	9.0	3.9
1 1/2	---	9.50	10.7	5.5
2	---	11.50	11.3	6.3
2 1/2	119.1	13.00	17.0	11.0
3	138.9	14.00	18.8	12.4
4	264.6	17.00	20.9	12.4
6	480.7	22.00	26.6	17.7

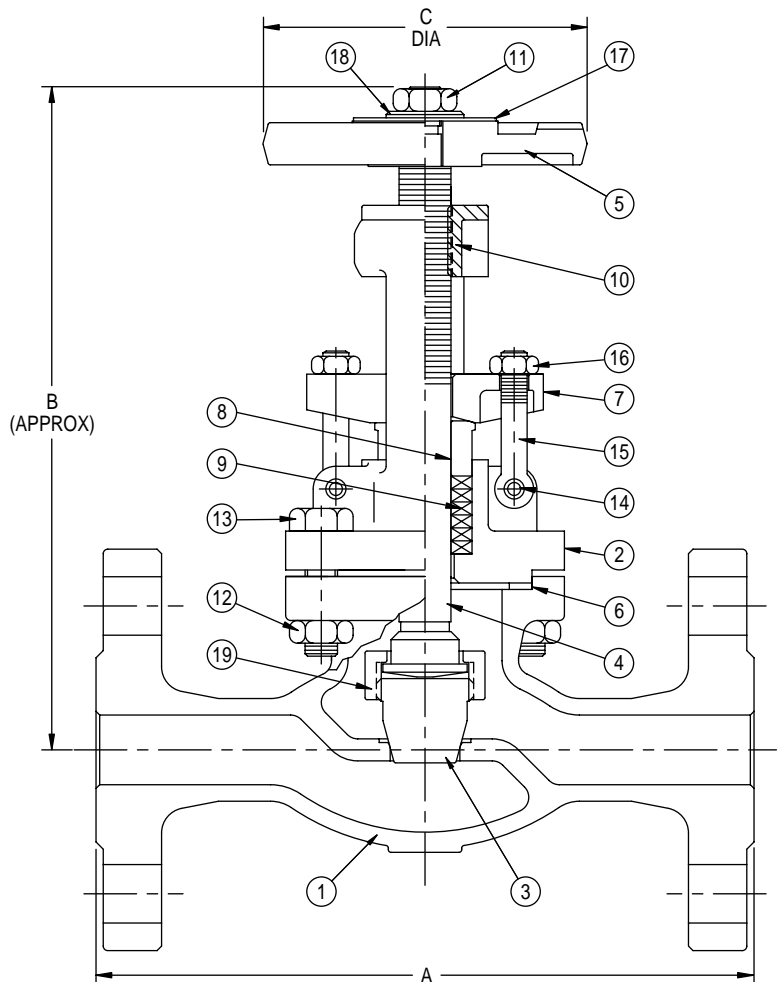

Fig. 4317

# Stainless Steel Check Valves

## 200 CWP • Y-Pattern • Threaded Cap

Figure 49  
Threaded Ends

**Size Range:**  
1/2 through 2 inches

**Design Features:**

- Integral Seat
- Y Pattern

**Pressure Temperature Ratings:**

- 200 psi @ -20°F to 100°F
- 135 psi @ 500°F Max

### Industry Standards

Pipe Threads	ASME B1.20.1
--------------	--------------

### Materials of Construction

1	Body	ASTM A351 CF8M
2	Cap	ASTM A351 CF8M
3	Disc	ASTM A351 CF8M
4	Hinge Arm	ASTM A351 CF8M
5	Hinge Pin	316 SS
6	Disc Nut	316 SS
7	Disc Washer	316 SS
8	Plug	316 SS
9	Seal	PTFE
10	Gasket	PTFE

### Dimensions and Weights

Valve Size	Weight (lbs)	Dimensions (inches)	
		A	B
1/2	0.7	2.56	1.8
3/4	1.1	3.15	2.0
1	1.5	3.54	2.4
1 1/2	3.1	4.72	3.2
2	4.6	5.51	3.7

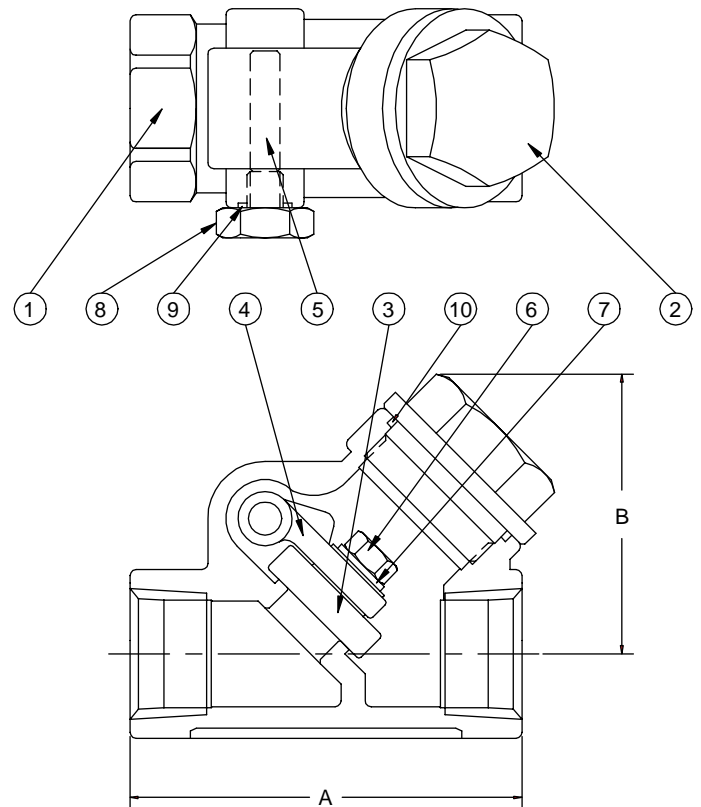

**Fig. 49**

## Class 150 • Bolted Cover

### Figure 370

Threaded Ends

### Figure 374

Socket Weld Ends

#### Size Range:

1/2 through 2 inches

#### Design Features:

- Retained Gasket
- Integral Seat
- ASME B16.34

#### Industry Standards

Pipe Threads	ASME B2.1
Wall Section	ASME B16.34
Socket Weld Ends	ASME B16.11
End-to-End	Manufacturer's Standard
Pressure Temp. Ratings	ASME B16.34
Testing	API 598

#### Materials of Construction

1	Body	ASTM A351 CF3M
2	Cover	ASTM A351 CF8M
3	Disc	ASTM A351 CF8M
4	Hinge Arm	ASTM A351 CF8M
5	Hinge Pin	ASTM A276 T316
6	Disc Washer	ASTM A276 T304
7	Disc Nut	ASTM A194 GR 8
8	Plug	ASTM A276 T316
9	Gasket	PTFE
10	Plug Seal	PTFE
11	Cover Bolt	ASTM A193 GR B8
12	Cover Bolt Nut	ASTM A194 GR 8
13	ID Tag	ASTM A276 T304

#### Dimensions and Weights

Valve Size	Weight (lbs)	Dimensions (inches)		
		A	B	C*
1/2	3.5	3.35	2.4	.38
3/4	3.7	3.74	2.8	.50
1	5.5	4.53	3.1	.50
1 1/2	8.6	4.92	4.1	.50
2	10.3	5.91	4.6	.62

\* For Figure 374 only - socket weld depth

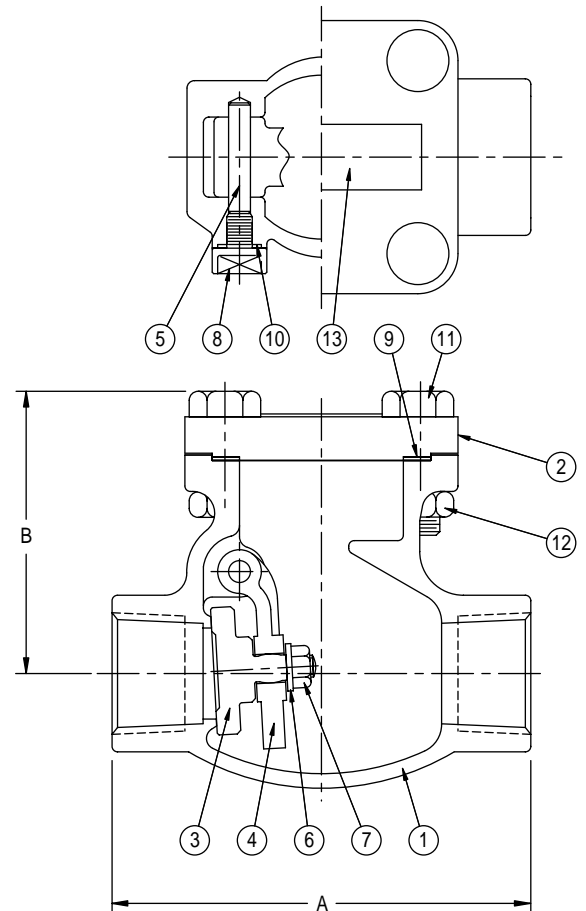

**Fig. 370**

# Stainless Steel Check Valves

## Class 150 • Bolted Cover

Figure 377

Raised Face, Flanged Ends

**Size Range:**

1/2 through 24 inches

**Design Features:**

- Retained Gasket
- Integral Seat
- MSS-SP-42
- ASME B16.34

**Industry Standards**

End Flanges	ASME B16.5
Wall Section	ASME B16.34
Face-to-Face	ASME B16.10
Pressure-Temp. Ratings	ASME B16.34
Testing	API 598

**Materials of Construction**

1	Body	ASTM A351 CF8M
2	Cover	ASTM A351 CF8M
3	Disc	ASTM A351 CF8M
4	Hinge Arm	ASTM A351 CF8M
5	Hinge Pin	ASTM A276 T316
6	Disc Washer	ASTM A276 T304
7	Disc Nut	ASTM A194 GR 8M
8	Plug	ASTM A276 T316
9	Gasket	PTFE
10	Plug Seal	PTFE
11	Cover Bolt	ASTM A193 GR B8
12	Cover Bolt Nut	ASTM A194 GR 8
13	ID Tag	ASTM A276 T304

**Dimensions and Weights**

Valve Size	Weight (lbs)	Dimensions (inches)	
		A	B
1/2	4.2	4.25	2.4
3/4	5.6	4.63	2.8
1	8.4	5.00	3.1
1 1/2	13.5	6.50	4.1
2	20.4	8.00	4.6
2 1/2	50.7	8.50	6.1
3	57.3	9.50	6.3
4	99.2	11.50	7.9
6	172.0	14.00	9.8
8	299.9	19.50	11.5
10	471.9	24.50	13.0
12	707.8	27.50	13.9
14	904.1	31.00	15.5
16	1133.4	34.00	16.5
18	1633.9	38.50	20.1
20	2070.5	38.50	21.7
24	2967.9	51.00	22.0

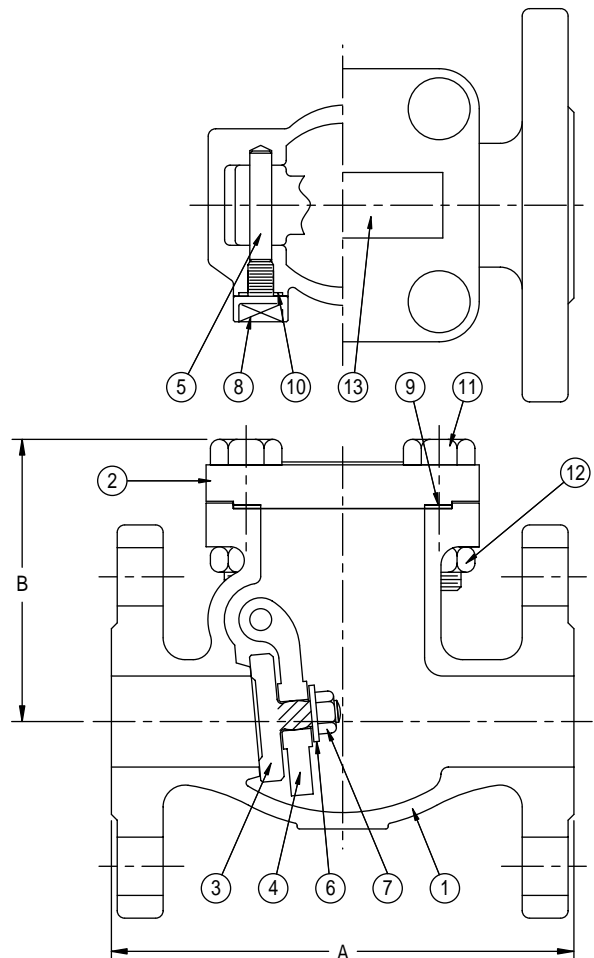

Fig. 377



## Class 300 • Bolted Cover

### Figure 2370

Threaded Ends

### Figure 2374

Socket Weld Ends

#### Size Range:

1/2 through 2 inches

#### Design Features:

- Retained Gasket
- Integral Seat

### Industry Standards

Pipe Threads	ASME B1.20.1
Wall Section	ASME B16.34
Socket Weld Ends	ASME B16.11
End-to-End	Manufacturer's Standard
Pressure Temp. Ratings	ASME B16.34
Testing	API 598

### Materials of Construction

1	Body	ASTM A351 CF3M
2	Cover	ASTM A351 CF8M
3	Disc	ASTM A351 CF8M
4	Hinge Arm	ASTM A351 CF8M
5	Hinge Pin	ASTM A276 T316
6	Disc Washer	ASTM A276 T304
7	Disc Nut	ASTM A194 GR 8
8	Gasket	PTFE
9	Cover Bolt	ASTM A193 GR B8
10	Cover Bolt Nut	ASTM A194 GR 8
11	ID Tag	ASTM A276 T304

### Dimensions and Weights

Valve Size	Weight (lbs)	Dimensions (inches)		
		A	B	C*
1/2	4.2	3.23	3.3	.38
3/4	4.2	3.23	3.3	.50
1	5.8	4.13	3.4	.50
1 1/2	10.1	4.92	3.9	.50
2	13.1	5.31	4.1	.62

\* For Figure 2374 only - socket weld depth

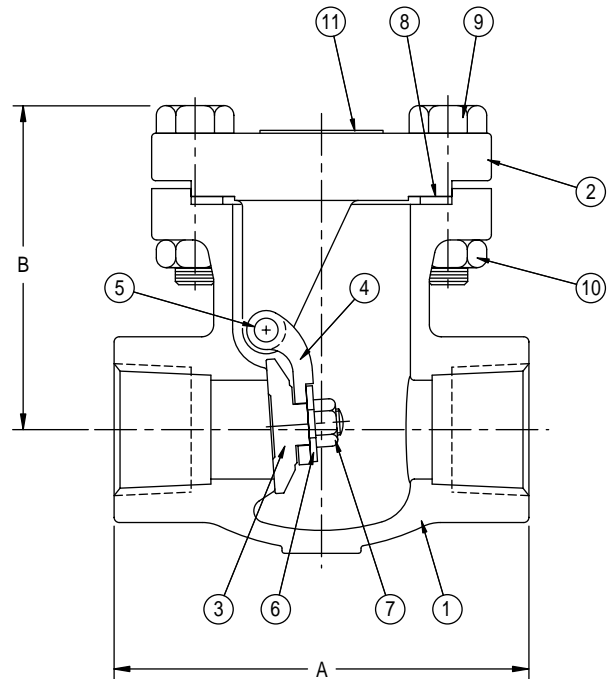

**Fig. 2370**

# Stainless Steel Check Valves

## Class 300 • Bolted Cover

**Figure 2377**  
Raised Face, Flanged Ends

**Size Range:**  
1/2 through 24 inches

- Design Features:**
- Retained Gasket
  - Integral Seat
  - MSS-SP-42

### Industry Standards

End Flanges	ASME B16.5
Wall Section	ASME B16.34
Face-to-Face	ASME B16.10
Pressure-Temp. Ratings	ASME B16.34
Testing	API 598

### Materials of Construction

1	Body	ASTM A351 CF8M
2	Cover	ASTM A351 CF8M
3	Disc	ASTM A351 CF8M
4	Hinge Arm	ASTM A351 CF8M
5	Hinge Pin	ASTM A276 T316
6	Disc Washer	ASTM A276 T304
7	Disc Nut	ASTM A194 GR 8
8	Gasket	PTFE
9	Cover Bolt	ASTM A193 GR B8
10	Cover Bolt Nut	ASTM A194 GR 8
11	ID Tag	ASTM A276 T304

### Dimensions and Weights

Valve Size	Weight (lbs)	Dimensions (inches)	
		A	B
1/2	---	6.00	3.3
3/4	---	7.00	3.3
1	---	8.50	3.4
1 1/2	---	9.50	3.9
2	---	10.50	4.1
2 1/2	81.6	11.50	6.5
3	92.6	12.50	6.9
4	141.1	14.00	7.3
6	273.4	17.50	10.3
8	489.5	21.00	12.3
10	643.9	24.50	14.0
12	979.0	28.00	15.5
14	1420.0	33.00	20.1
16	1753.0	34.00	20.5
18	2319.7	38.50	22.5
20	2668.1	40.00	24.5
24	4224.8	53.00	28.0

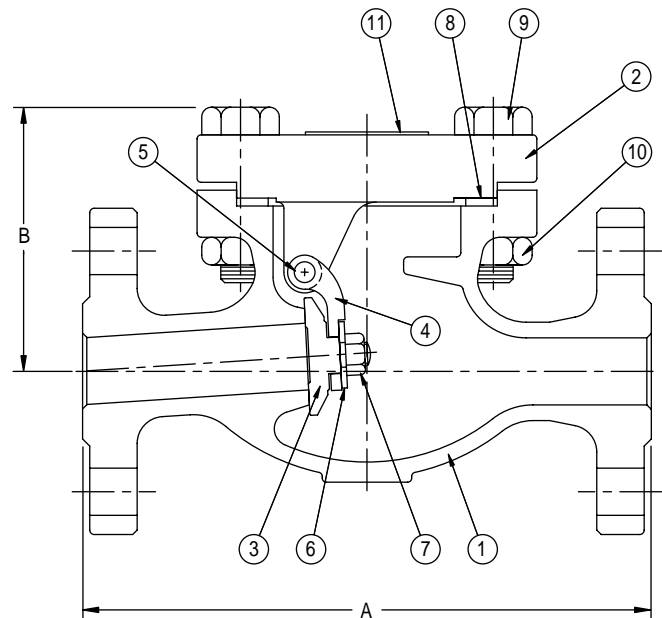

**Fig. 2377**



## Class 600 • Bolted Cover

### Figure 4370

Threaded Ends

### Figure 4374

Socket Weld Ends

#### Size Range:

1/2 through 2 inches

#### Design Features:

- Retained Gasket
- Integral Seat

### Industry Standards

Pipe Threads	ASME B1.20.1
Wall Section	ASME B16.34
Socket Weld Ends	ASME B16.11
End-to-End	Manufacturer's Standard
Pressure Temp. Ratings	ASME B16.34
Testing	API 598

### Materials of Construction

1	Body	ASTM A351 CF3M
2	Cover	ASTM A351 CF8M
3	Disc	ASTM A351 CF8M
4	Hinge Arm	ASTM A351 CF8M
5	Hinge Pin	ASTM A276 T316
6	Disc Washer	ASTM A276 T304
7	Disc Nut	ASTM A194 GR 8
8	Gasket	PTFE
9	Cover Bolt	ASTM A193 GR B8
10	Cover Bolt Nut	ASTM A194 GR 8
11	ID Tag	ASTM A276 T304

### Dimensions and Weights

Valve Size	Weight (lbs)	Dimensions (inches)		
		A	B	C*
1/2	4.2	3.23	3.3	.38
3/4	4.2	3.23	3.3	.50
1	5.8	4.13	3.4	.50
1 1/2	10.1	4.92	3.9	.50
2	13.1	5.31	4.1	.62

\* For Figure 4374 only - socket weld depth

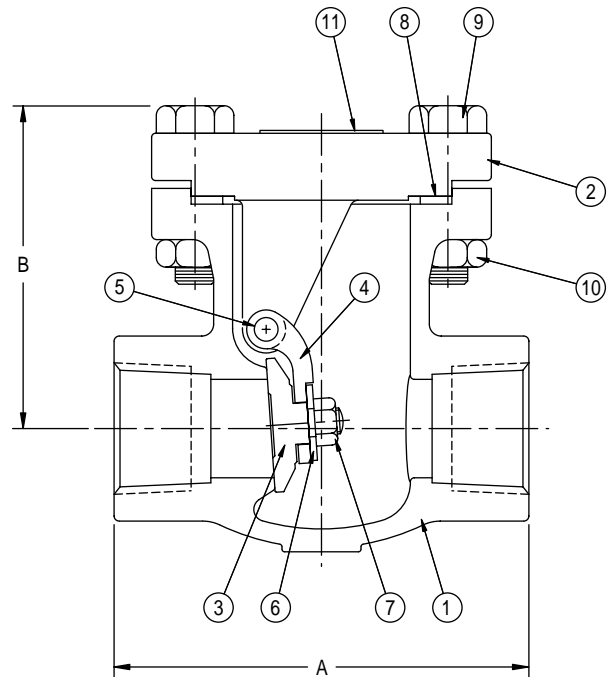

**Fig. 4370**

# Stainless Steel Check Valves

## Class 600 • Bolted Cover

**Figure 4377**  
Raised Face, Flanged Ends

**Size Range:**  
1/2 through 12 inches

- Design Features:**
- Retained Gasket
  - Integral Seat
  - MSS SP-42

### Industry Standards

End Flanges	ASME B16.5
Wall Section	ASME B16.34
Face-to-Face	ASME B16.10
Pressure-Temp. Ratings	ASME B16.34
Testing	API 598

### Materials of Construction

1	Body	ASTM A351 CF8M
2	Cover	ASTM A351 CF8M
3	Disc	ASTM A351 CF8M
4	Hinge Arm	ASTM A351 CF8M
5	Hinge Pin	ASTM A276 T316
6	Disc Washer	ASTM A276 T304
7	Disc Nut	ASTM A194 GR 8
8	Gasket	PTFE
9	Cover Bolt	ASTM A193 GR B8
10	Cover Bolt Nut	ASTM A194 GR 8
11	ID Tag	ASTM A276 T304

### Dimensions and Weights

Valve Size	Weight (lbs)	Dimensions (inches)	
		A	B
1/2	---	6.50	3.3
3/4	---	7.50	3.3
1	---	8.50	3.4
1 1/2	---	9.50	3.9
2	---	11.50	4.1
2 1/2	108.0	13.00	7.9
3	123.5	14.00	8.3
4	227.1	17.00	10.1
6	449.8	22.00	13.0
8	754.1	26.00	14.3
10	1375.9	31.00	18.3
12	1711.1	33.00	19.1

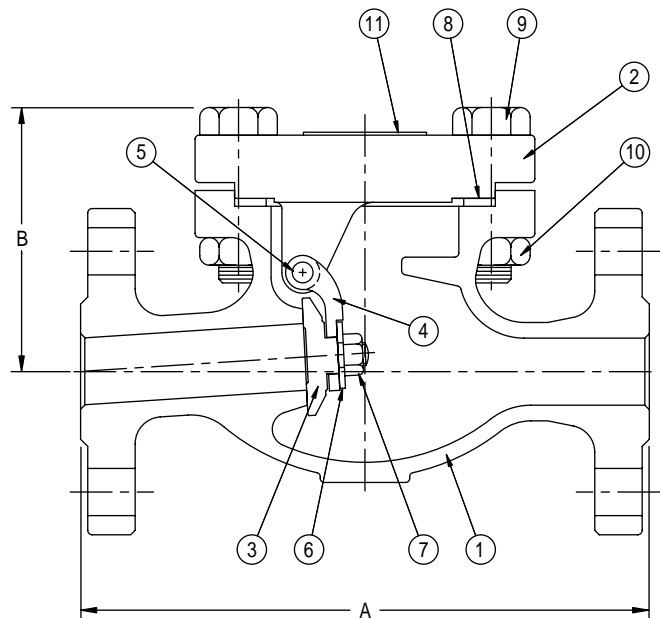

**Fig. 4377**

# FIGURE 9502

# Stainless Steel Ball Valves

## 2000/1500 CWP • Two-Piece Body

### Figure 9502

Threaded Ends

#### Size Range:

1/4 through 2 inches

#### Design Features:

- MSS SP-110
- Standard Port
- Locking Handle
- ISO 5211 Mounting

### Materials of Construction

1	Body	CF8M
2	Cap	CF8M
3	Ball	Type 316
4	Seat	RPTFE
5	Body Seal	PTFE
6	Stem	Type 316
7	Thrust Washer	PTFE
8	Stem Packing	PTFE
9	Gland Nut	AISI 304
10	Stem Washer	AISI 304
11	Stem Nut	AISI 304
12	Handle	AISI 304
13	Handle Sleeve	Plastic
14	Locking Device	AISI 304

### Dimensions and Weights

Valve Size	Weight (lbs)	Dimensions (inches)			
		L	D	C	H
1/4	.66	2.24	.43	2.0	3.94
3/8	.66	2.24	.51	2.0	3.94
1/2	.66	2.36	.51	2.0	3.94
3/4	1.21	3.11	.71	2.5	4.84
1	1.21	3.35	.87	2.7	4.84
1 1/4	2.98	4.02	1.0	3.3	5.67
1 1/2	3.64	4.37	1.2	3.5	5.67
2	5.51	5.39	1.5	3.7	5.67

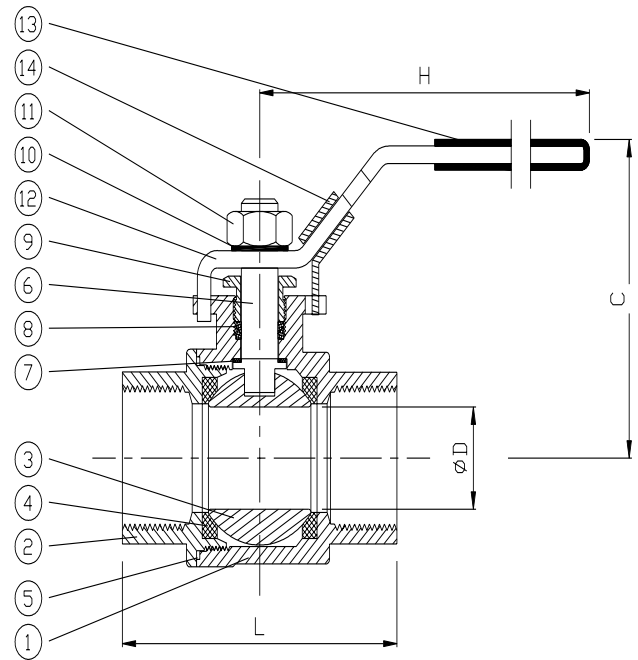

Fig. 9502

# Materials of Construction

Composition, %					
Element	ASTM A351			ASTM A494	
	CF8M	CF3M	CN7M	M-35-1	CW-12MW
Carbon	0.08	0.03	0.07	0.35	0.12
Chromium	18.0 - 21.0	17.0 - 21.0	19.0 - 22.0	0.00	15.5 - 17.5
Columbium (Niobium)	0.00	0.00	0.00	0.50	0.00
Copper	0.00	0.00	3.0 - 4.0	26.0 - 33.0	0.00
Iron	0.00	0.00	0.00	3.50	4.5 - 7.5
Manganese	1.50	1.50	1.50	1.50	1.00
Molybdenum	2.0 - 3.0	2.0 - 3.0	2.0 - 3.0	0.00	16.0 - 18.0
Nickel	9.0 - 12.0	9.0 - 13.0	27.5 - 30.5	balance	balance
Phosphorus	0.04	0.04	0.04	0.03	0.04
Silicon	1.50	1.50	1.50	1.25	1.00
Sulfur	0.04	0.04	0.04	0.03	0.03
Tungsten	0.00	0.00	0.00	0.00	3.75 - 5.25
Vanadium	0.00	0.00	0.00	0.00	0.20 - 0.40

Assume all values are maximum, unless a range is given

	Tensile Requirements			Mechanical Properties	
Tensile Strength	70,000	70,000	62,000	65,000	72,000
Yield Strength	30,000	30,000	25,000	25,000	40,000
Elongation in 2 inches, %	30.0%	30.0%	35.0%	25.0%	4.0%

# Pressure Temperature

Temp F	ASTM A351 Gr. CF8M			ASTM A351 Gr. CF3M			ASTM A351 Gr. CN7M			ASTM A494 M-35-1			ASTM A494 Gr. CW-12MW		
	Working Pressure (psig)			Working Pressure (psig)			Working Pressure (psig)			Working Pressure (psig)			Working Pressure (psig)		
	CL. 150	CL. 300	CL. 600	CL. 150	CL. 300	CL. 600	CL. 150	CL. 300	CL. 600	CL. 150	CL. 300	CL. 600	CL. 150	CL. 300	CL. 600
-20 to 100	275	720	1,440	230	600	1,220	230	600	1,200	230	600	N/A	230	600	1,200
200	235	620	1,240	195	505	1,015	200	520	1,045	200	525	N/A	205	540	1,080
300	215	560	1,120	175	455	910	190	490	980	190	490	N/A	195	505	1,015
400	195	515	1,025	160	415	825	190	490	980	180	475	N/A	185	480	960
500	170	480	955	145	380	765	170	490	980	170	470	N/A	170	455	910
600	140	450	900	140	360	720	140	490	980	140	470	N/A	140	440	880
650	125	445	890	125	350	700	125	490	980	125	435	N/A	125	425	850
700	110	430	870	110	345	685	110	490	980	110	405	N/A	110	420	840
750	95	425	855	95	335	670	95	490	980	95	405	N/A	95	415	825
800	80	420	845	80	330	660	80	490	980	80	405	N/A	80	410	815
850	65	420	835	65	320	645				65	325	N/A	65	400	795
900	50	415	830							50	245	N/A	50	395	790
950	35	385	775							25	120	N/A	35	385	775
1000	20	350	700										20	365	725
1050	20 *	345	685												
1100	20 *	305	610												
1150	20 *	235	475												
1200	20 *	185	370												
1250	20 *	145	295												
1300	20 *	115	235												
1350	20 *	95	190												
1400	20 *	75	150												
1450	20 *	60	115												
1500	15 *	40	85												

\* Rating for weld-end valves.  
Flanged End valves rated to 1000°F maximum

Use solution annealed material only  
Not to be used over 1000°F maximum

Hydrostatic Shell Test Pressures			
Class	150	300	600
Pressure	425	1,100	2,175

NOTE: These are design pressure ratings from ASME B16.34-1996 and apply to castings only. Packing and gasket materials may limit temperature range of specific products.

# Stainless Steel Valves

## Valve Marking System

It is important to properly identify valves in service to allow for the ordering of replacement parts or to address questions or concerns relating to Alloyco products. The valve marking system shown here will help customers identify valves accurately, speeding responses to customer service issues.

### Valve Marking System Codes

<b>AAAA</b>	Material (CF3M, CF8M, etc.)
<b>BBB</b>	Size (1/2", 4", etc.)
<b>CCC</b>	Class (150, 300, 600)
<b>DDD</b>	Manufacturer ID Number
<b>EEEEEEEEEE</b>	Serial Number
<b>FF</b>	Foundry Number
<b>GGGGGG</b>	Heat Number

### Gate Valve

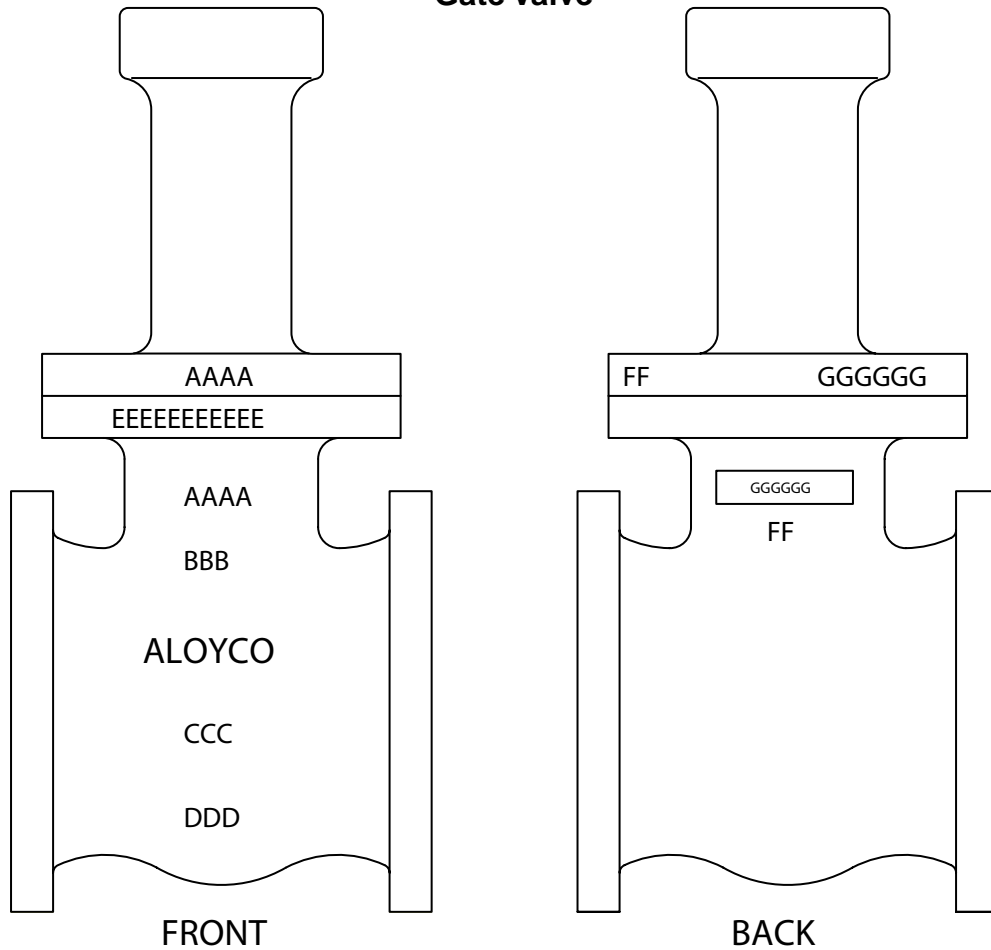

# Stainless Steel Valves

## Valve Marking System

### Globe Valve

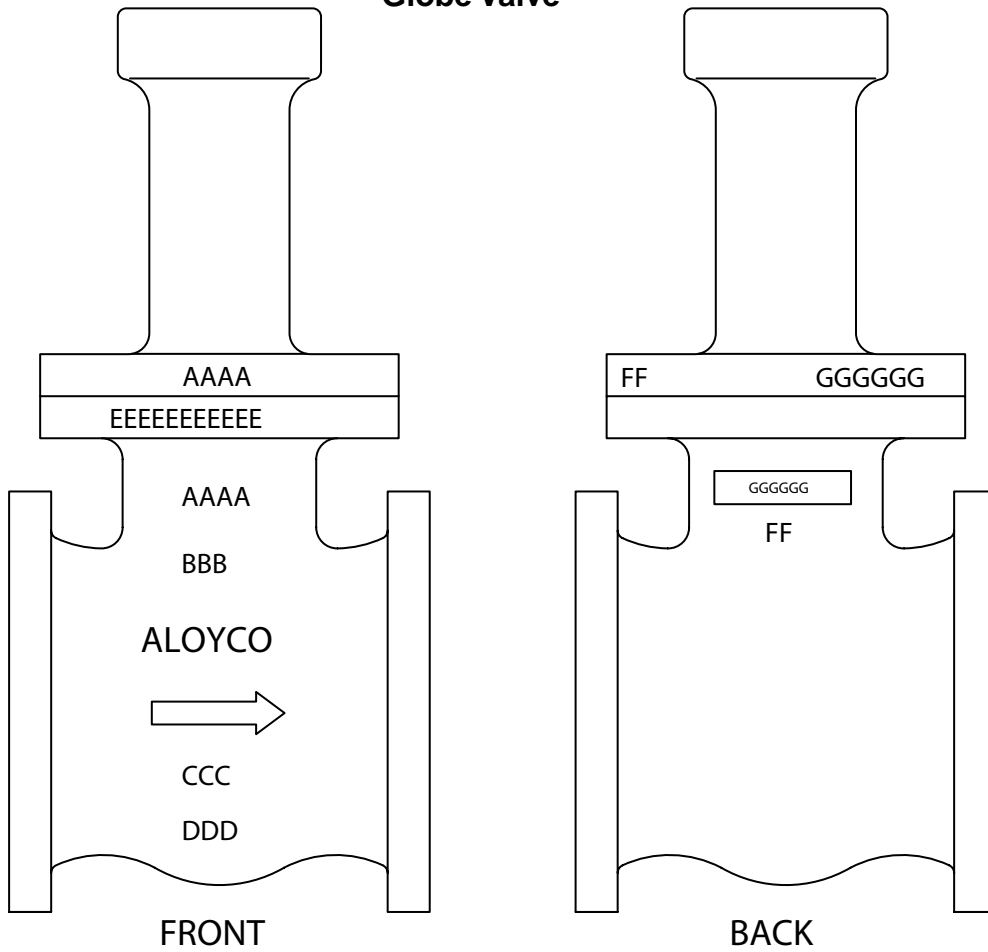

### Check Valve

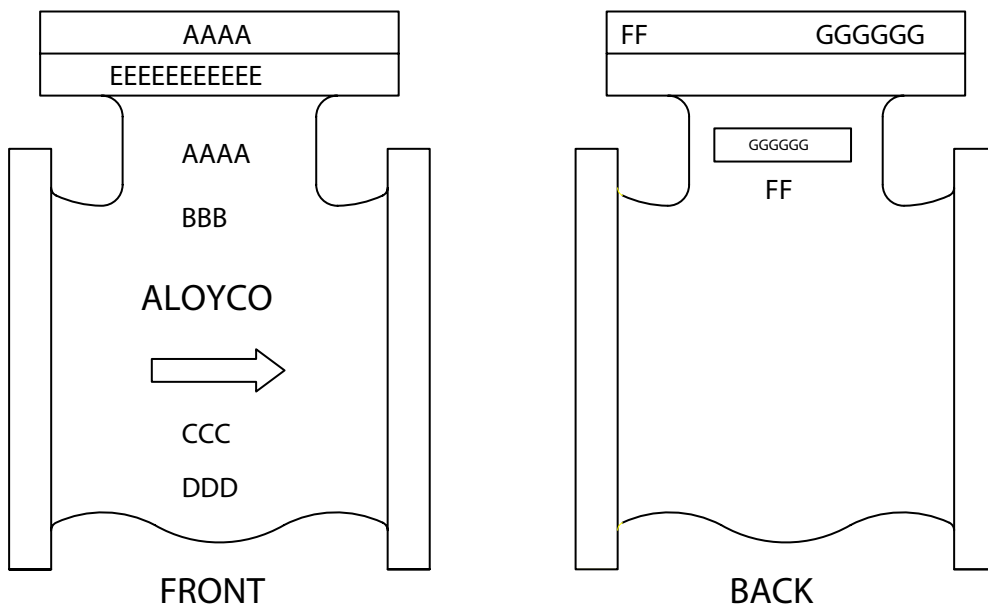



**"WE WROTE THE BOOK"**

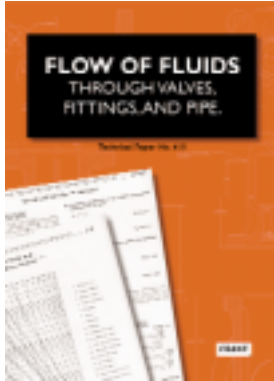

**ALOYCO**

2129 3rd Avenue, S.E.  
Cullman, AL 35055  
Tel: 800-786-2542  
Fax: 256-775-3860

[www.cranevalve.com](http://www.cranevalve.com)

Aloyco is a trademark of Crane Co.

**CRANE**

THE VALVE EXPERTS