

FK Series Butterfly Valves

Product Data Sheet



introduction

< STANDARDS >



ASTM D4101-86
ASTM D1784
ASTM D3222



ANSI B16.5

IPEX FK Series Butterfly Valves offer superior strength and chemical resistance in highly corrosive environments and process flow conditions. The special trapezoid shape of the liner and a serrated body cavity guarantee a bubble tight seal while keeping break-away torque at an absolute minimum. This versatile industrial valve features double self-lubricating seals, direct actuator mount capability, and the option of either a lever handle or mounted gear box. A special integral stainless steel lug version provides for full bi-directional operation allowing disassembly of the downstream flange connection without weakening the integrity of the upstream connection to the pressurized line. FK Series Butterfly Valves are part of our complete systems of pipe, valves, and fittings, engineered and manufactured to our strict quality, performance, and dimensional standards.

Valve Availability

Body Material:	Glass reinforced PP (GRPP)
Disc Material:	PP, PVC, CPVC, PVDF
Size Range:	1-1/2" through 12"
Pressure:	150 psi (1-1/2" to 10"), 120 psi (12")
Seats:	EPDM or Viton® (FPM)
Seals:	EPDM or Viton® (FPM)
Body Style:	Wafer or Lugged
Control Style:	Lever Handle or Mounted Gear Box
End Connections:	Flanged (ANSI 150)



FK Series Butterfly Valves

Sample Specification



1.0 Butterfly Valves - FK

1.1 Material

- The valve body shall be made of glass reinforced polypropylene (GRPP) obtained from homopolymer polypropylene (PPH).
- The valve disc shall be made of stabilized PP homopolymer compound, also containing a RAL 7032 pigment, which shall meet or exceed the requirements of Type I Polypropylene according to ASTM D4101-86.
- or The valve disc shall be made of PVC compound which shall meet or exceed the requirements of cell classification 12454 according to ASTM D1784.
- or The valve disc shall be made of Corzan® CPVC compound which shall meet or exceed the requirements of 23447 according to ASTM D1784.
- or The valve disc shall be made of virgin, non-regrind PVDF compound which shall meet or exceed the requirements of Table 1 according to ASTM D3222.
- These compounds shall comply with standards that are equivalent to NSF Standard 61 for potable water.
- The valve shaft shall be made of 420 stainless steel.

1.2 Seats

- The disc liner shall be made of EPDM which shall comply with standards that are equivalent to NSF Standard 61 for potable water.
- or The disc liner shall be made of Viton® (FPM) which shall comply with standards that are equivalent to NSF Standard 61 for potable water.

1.3 Seals

- The o-ring seals shall be made of EPDM which shall comply with standards that are equivalent to NSF Standard 61 for potable water.
- or The o-ring seals shall be made of Viton® (FPM) which shall comply with standards that are equivalent to NSF Standard 61 for potable water.

1.4 All other wetted and non-wetted parts of the valves shall comply with standards that are equivalent to NSF Standard 61 for potable water.

2.0 Connections

2.1 Flanged style

- The ANSI 150 flanged connections shall conform to the dimensional standard ANSI B16.5.

FK Series Butterfly Valves

Sample Specification (cont'd)



3.0 Design Features

- The valve shall be of either wafer or lugged design (specifier must select one).
- The lugged style shall feature permanently integrated stainless steel lugs.
- Manual control of the valve shall be achieved through the use of either a lever handle or mounted gear box (specifier must select one).
- The shaft shall have standard ISO square dimensions for direct mounting of actuators.
- The disc seat shall be a trapezoidal elastomeric liner and provide a bubble tight seal.
- The liner shall completely isolate the valve body from the process flow.
- The liner shall function as a flange gasket on both sides of the valve.
- The body cavity shall feature special channeling to prevent liner slippage and compression.
- The disc, seats, and seals shall be the only wetted parts.
- Teflon® seated o-ring seals shall prevent the stainless steel shaft from becoming wetted.

3.1 Pressure Rating

- Valve sizes 1-1/2" through 10" shall be rated at 150 psi at 73°F.
- Valve sizes 12" shall be rated at 120 psi at 73°F.

3.2 Markings

- All valves shall be marked to indicate size, material designation, and manufacturer's name or trade mark.

3.3 Color Coding

- All valves shall be color-coded beige gray.

4.0 All valves shall be by IPEX or approved equal.

FK Series Butterfly Valves

Valve Selection

lever handle style

Size (inches)	Disc Material	Body Style	O-ring Material	IPEX Part Number	Pressure Rating @ 73°F
1-1/2	PP	Wafer	EPDM	053198	150 psi
			Viton®	053200	
2		Wafer	EPDM	053199	
			Viton®	053201	
2-1/2		Wafer	EPDM	052145	
			Viton®	052147	
		SS Lugs	EPDM	053133	
			Viton®	053139	
3		Wafer	EPDM	053105	
			Viton®	053153	
		SS Lugs	EPDM	053134	
			Viton®	053140	
4		Wafer	EPDM	053106	
			Viton®	053154	
		SS Lugs	EPDM	053135	
			Viton®	053141	
5	Wafer	EPDM	052146		
		Viton®	052148		
	SS Lugs	EPDM	053136		
		Viton®	053142		
6	Wafer	EPDM	053107		
		Viton®	053155		
	SS Lugs	EPDM	053137		
		Viton®	053143		
8	Wafer	EPDM	053108		
		Viton®	053156		
	SS Lugs	EPDM	053138		
		Viton®	053144		

Note: PVC, CPVC and PVDF discs are available upon request.
 Sizes 14" through 24" valves are available upon request.

Size (inches):

- 1-1/2
- 2
- 2-1/2
- 3
- 4
- 5
- 6
- 8
- 10
- 12

Control Style:

- Lever Handle
- Mounted Gear Box

Body Style:

- Wafer
- SS Lugs

Seals:

- EPDM
- Viton® (FPM)

IPEX Part Number:

Infinite adjustable handle kit

Valve Size (inches)	IPEX Part Number
2-1/2	153968
3	153969
4	153969
5	153970
6	153970
8	153971



FK Series Butterfly Valves

Valve Selection (cont'd)

mounted gear box style

Size (inches)	Disc Material	Body Style	O-ring Material	IPEX Part Number	Pressure Rating @ 73°F
2-1/2	PP	Wafer	EPDM	253145	150 psi
			Viton®	253147	
SS Lugs		EPDM	253133		
		Viton®	253139		
3		Wafer	EPDM	253105	
			Viton®	253153	
SS Lugs		EPDM	253134		
		Viton®	253140		
4		Wafer	EPDM	253106	
			Viton®	253154	
SS Lugs		EPDM	253135		
		Viton®	253141		
5	Wafer	EPDM	253146		
		Viton®	253148		
SS Lugs	EPDM	253136			
	Viton®	253142			
6	Wafer	EPDM	253107		
		Viton®	253155		
SS Lugs	EPDM	253137			
	Viton®	253143			
8	Wafer	EPDM	253108		
		Viton®	253156		
SS Lugs	EPDM	253138			
	Viton®	253144			
10	Wafer	EPDM	153014		
		Viton®	153016		
SS Lugs	EPDM	053328			
	Viton®	053330			
12	Wafer	EPDM	153015		
		Viton®	153017		
SS Lugs	EPDM	053329			
	Viton®	053331			

Note: PVC, CPVC and PVDF discs are available upon request.
 Sizes 14" through 24" valves are available upon request.



IPEX

FK Series Butterfly Valves

Technical Data

dimensions

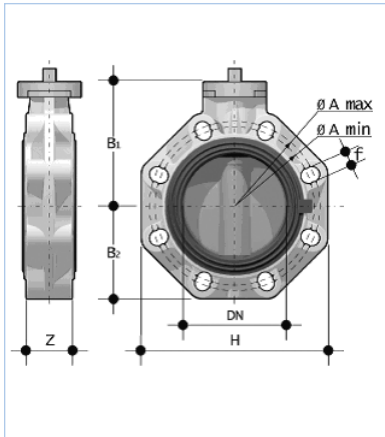

Size	DN	Z	Dimension (inches)						
			B ₁	B ₂	H	A _{min}	A _{max}	f	# holes
1-1/2	1.57	1.30	4.17	2.36	5.20	3.90	4.29	0.75	4
2	1.97	1.69	4.41	2.76	5.79	4.53	4.94	0.75	4
2-1/2	2.56	1.81	4.69	3.15	6.50	5.04	5.67	0.75	4
3	3.15	1.93	5.24	3.66	7.28	5.71	6.30	0.75	8
4	3.94	2.20	5.79	4.21	8.31	6.50	7.48	0.75	8
5	4.92	2.52	6.57	4.72	9.45	8.03	8.46	0.91	8
6	5.91	2.76	7.09	5.28	10.55	9.06	9.53	0.91	8
8	7.87	2.80	8.94	6.34	12.72	11.02	11.73	0.91	8
10	9.84	4.49	9.76	8.27	15.94	13.19	14.25	1.00	12
12	11.81	4.49	12.01	9.65	18.70	15.35	17.01	1.14	12

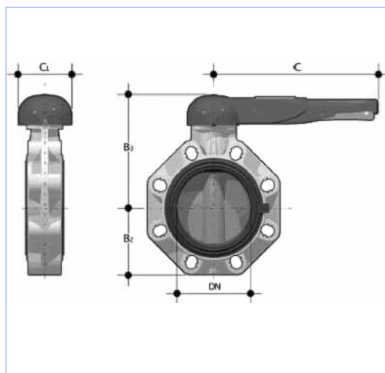

Size	DN	Lever Handle - Dimension (inches)					# holes
		C ₁	C	B ₂	B ₃		
1-1/2	1.57	3.94	6.89	2.36	5.39	4	
2	1.97	3.94	6.89	2.76	5.63	4	
2-1/2	2.56	4.33	10.71	3.15	6.46	4	
3	3.15	4.33	10.71	3.66	7.01	8	
4	3.94	4.33	10.71	4.21	7.56	8	
5	4.92	4.33	12.99	4.72	8.35	8	
6	5.91	4.33	12.99	5.28	8.86	8	
8	7.87	4.80	16.54	6.34	10.71	8	

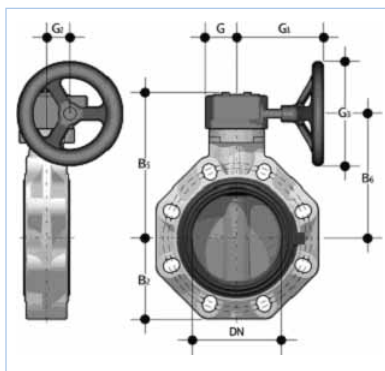

Size	DN	Mounted Gear Box - Dimension (inches)							
		G ₂	G	G ₁	G ₃	B ₂	B ₅	B ₆	# holes
2-1/2	2.56	1.54	1.89	5.31	4.92	3.15	6.85	5.75	4
3	3.15	1.54	1.89	5.31	4.92	3.66	7.40	6.30	8
4	3.94	1.54	1.89	5.31	4.92	4.21	7.95	6.85	8
5	4.92	1.54	1.89	5.67	7.87	4.72	8.74	7.64	8
6	5.91	1.54	1.89	5.67	7.87	5.28	9.25	8.15	8
8	7.87	2.36	2.56	8.03	7.87	6.34	11.30	10.08	8
10	9.84	2.99	3.46	9.29	9.84	8.27	12.48	11.06	12
12	11.81	2.99	3.46	9.29	9.84	9.65	14.72	13.31	12

FK Series Butterfly Valves

Technical Data (cont'd)

dimensions cont'd

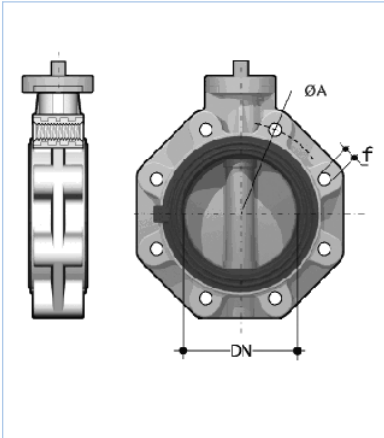

ANSI Lugged - Dimension (inches)				
Size	DN	A	f	# holes
1-1/2	1.57	3.87	1/2 - UNC	4
2	1.97	4.75	5/8 - UNC	4
2-1/2	2.56	5.50	5/8 - UNC	4
3	3.15	6.00	5/8 - UNC	8
4	3.94	7.50	5/8 - UNC	8
5	4.92	8.50	3/4 - UNC	8
6	5.91	9.50	3/4 - UNC	8
8	7.87	11.75	3/4 - UNC	8
10	9.84	14.25	7/8 - UNC	12
12	11.81	17.00	7/8 - UNC	12

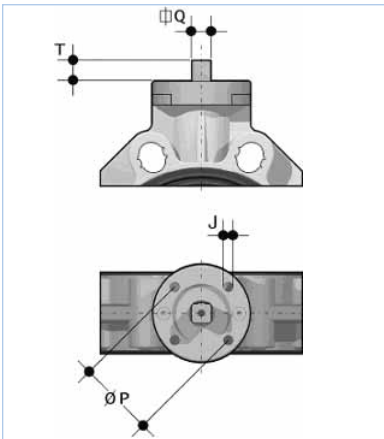

Mounting Pad for Actuation - Dimension (inches)					
Size	ISO	J	P	T	Q
1-1/2	F05	0.28	1.97	0.47	0.43
2	F05	0.28	1.97	0.47	0.43
2-1/2	F05 / F07	0.28 / 0.35	1.97 / 2.76	0.47	0.43
3	F07	0.35	2.76	0.63	0.55
4	F07	0.35	2.76	0.63	0.55
5	F07	0.35	2.76	0.75	0.67
6	F07	0.35	2.76	0.75	0.67
8	F10	0.43	4.02	0.94	0.87
10	F10 / F12 / F14	0.43 / 0.51 / 0.67	4.02 / 4.92 / 5.51	1.14	1.06
12	F10 / F12 / F14	0.43 / 0.51 / 0.67	4.02 / 4.92 / 5.51	1.14	1.06

FK Series Butterfly Valves

Technical Data (cont'd)

weights



Size	Approximate Weight (lbs)		
	Valve	w/ Handle	w/ Gear Box
1-1/2	1.27	1.98	-
2	1.66	2.38	-
2-1/2	2.20	3.24	5.29
3	3.09	4.12	6.17
4	3.86	4.89	6.94
5	5.62	6.83	9.81
6	7.28	8.49	11.46
8	13.23	14.88	20.50
10	26.46	-	41.01
12	41.89	-	56.44

pressure – temperature ratings

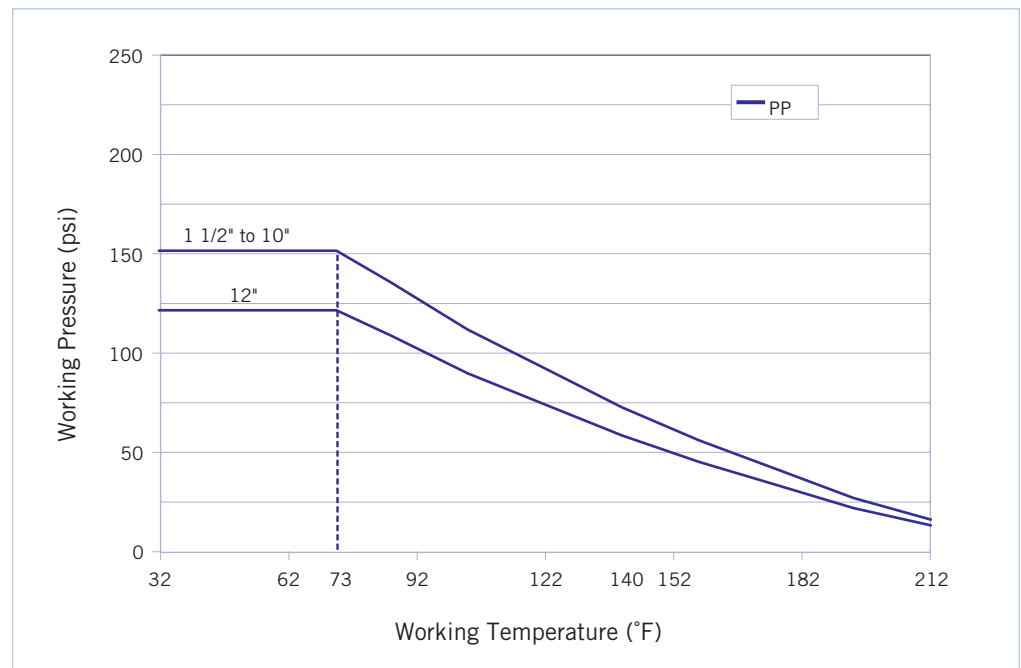

FK Series Butterfly Valves

Technical Data (cont'd)

pressure – temperature ratings cont'd

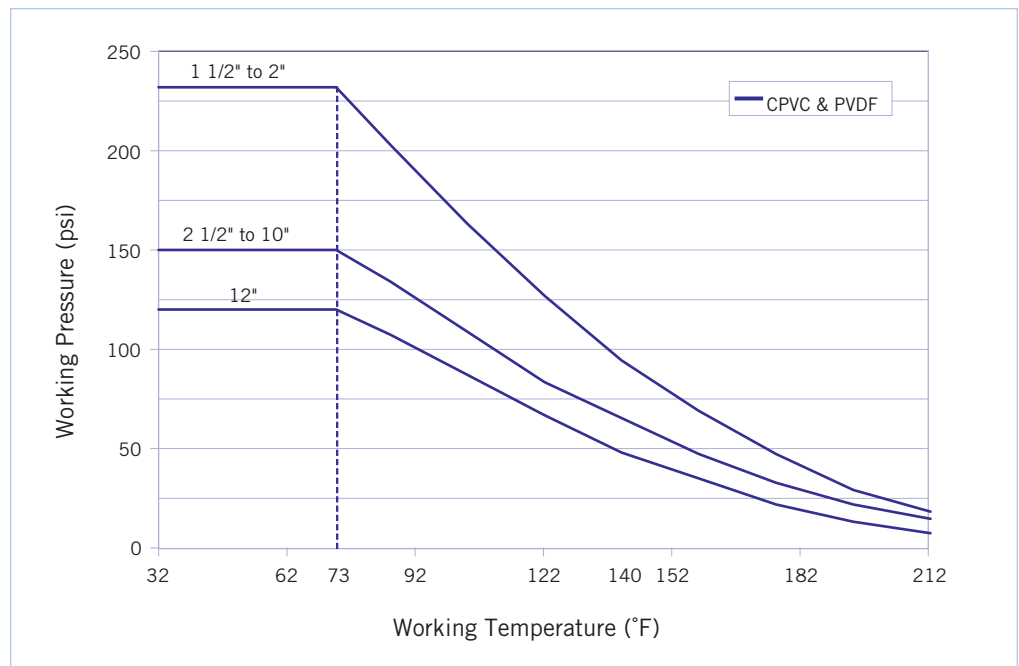
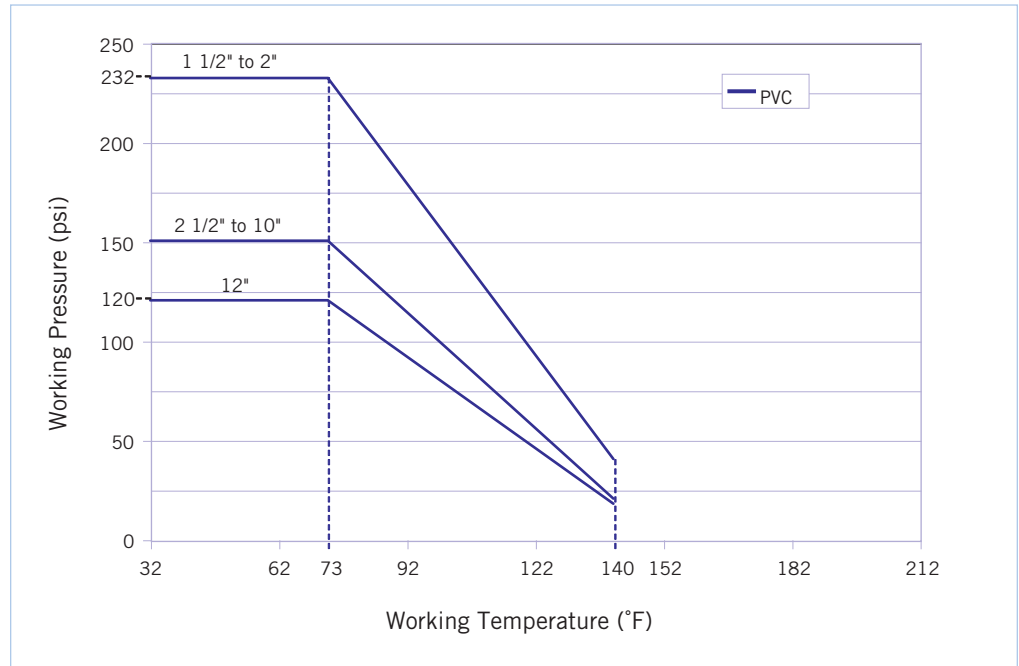

FK Series Butterfly Valves

Technical Data (cont'd)

flow coefficients

The flow coefficient (CV) represents the flow rate in gallons per minute (GPM) at 68°F for which there is a 1 psi pressure drop across the valve in the fully open position. These values are determined from an industry standard testing procedure which uses water as the flowing media (specific gravity of 1.0). To determine specific flow rate and pressure loss scenarios, one can use the following formula:

$$f = sg \times \left(\frac{Q}{C_V} \right)^2$$

Where,

f is the pressure drop (friction loss) in psi,

sg is the specific gravity of the fluid,

Q is the flow rate in GPM,

C_V is the flow coefficient.

Flow Coefficient Correction Factor

Use this chart to determine the appropriate flow coefficient correction factor depending on the amount of disc travel. As the valve cycles from fully open (100% travel) to fully closed (0% travel), the corresponding C_V value will decrease in accordance with the adjacent graph.

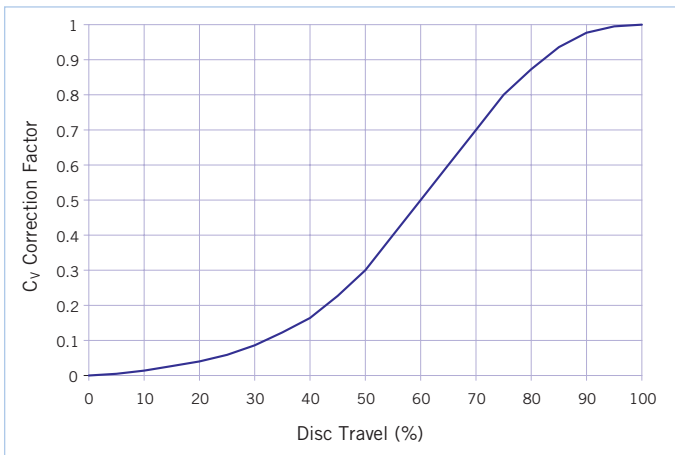

Size	C_V
1-1/2	70
2	90
2-1/2	119
3	249
4	413
5	690
6	1309
8	2135
10	3724
12	5712

pressure loss chart

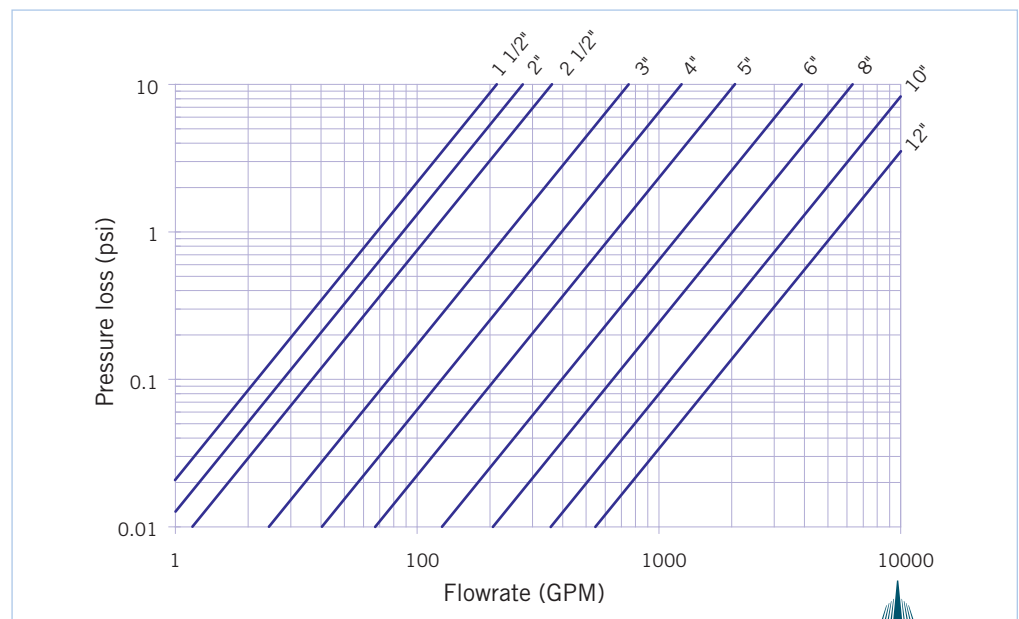

FK Series Butterfly Valves

Components

Sizes 1-1/2" to 2"

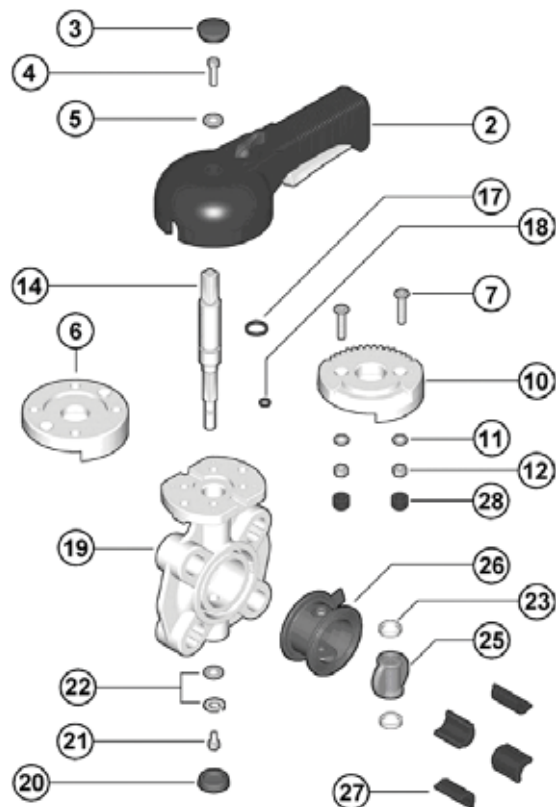

Sizes 2-1/2" to 8"

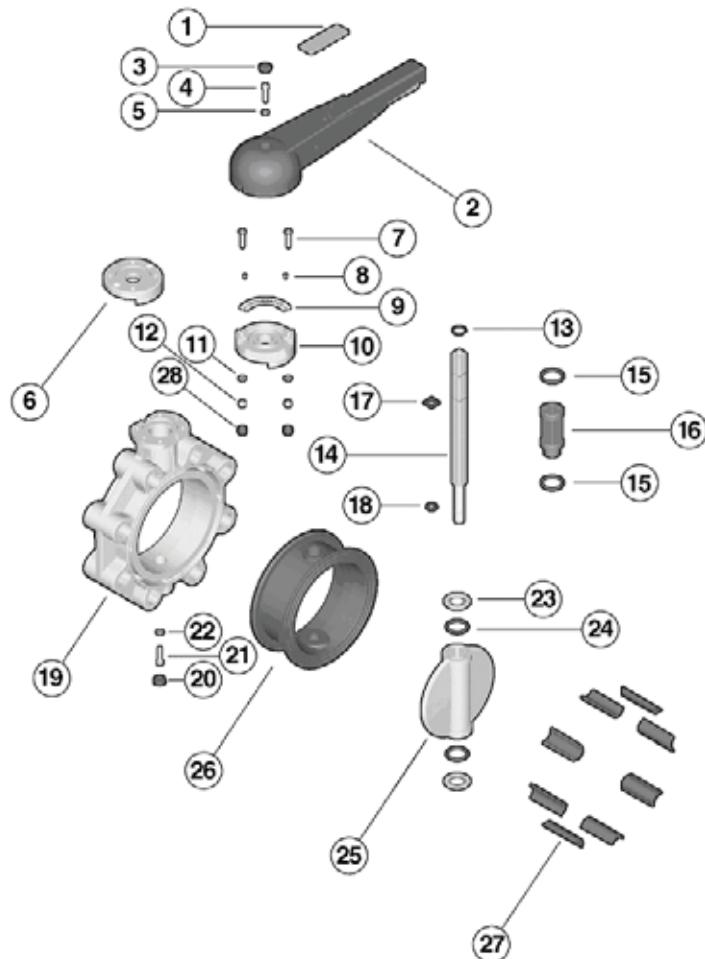

#	Component	Material	Qty
1*	handle insert	ABS	1
2*	handle	PVC	1
3*	cap	PE	1
4*	screw	SS	1
5*	washer	SS	1
6	spacer pad	GRPP	1
7	screw	SS	2
8	screw	SS	2
9	ratchet	SS	1
10	pad	GRPP	1
11	washer	SS	2
12	nut	SS	2
13	retaining ring	SS	1
14*	shaft	420 SS	1

#	Component	Material	Qty
15*	bushing o-ring	EPDM or Viton®	2
16	bushing	Nylon	1
17*	shaft o-ring	EPDM or Viton®	1
18*	shaft o-ring	EPDM or Viton®	1
19	body	GRPP	1
20	cap	PE	1
21	screw	SS	1
22	washer	SS	1
23*	anti-friction ring	PTFE	2
24*	disc o-ring	EPDM or Viton®	2
25*	disc	PP / PVC / CPVC / PVDF	1
26*	primary liner	EPDM or Viton®	1
27	inserts	ABS	4 or 8
28	cap	PE	2

* Spare parts available.



FK Series Butterfly Valves

Components (cont'd)

Sizes 10" to 12"

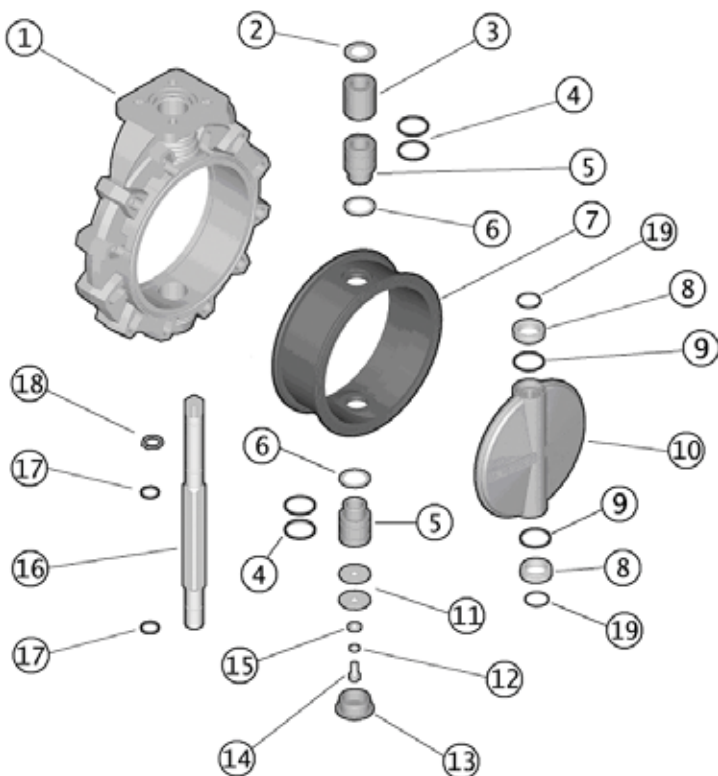

#	Component	Material	Qty
1	body	GRPP	1
2	washer	SS	1
3	bushing	PP	1
4*	bushing o-ring	EPDM or Viton®	4
5	bushing for o-ring	PP	2
6	washer	PTFE	2
7*	primary liner	EPDM or Viton®	1
8*	anti-friction ring	PTFE	2
9*	disc o-ring	EPDM or Viton®	2
10*	disc	PP / PVC / CPVC / PVDF	1
11	washer	SS	2
12	washer	SS	1
13	cap	PE	1
14	screw	SS	1
15	washer	SS	1
16*	shaft	420 SS	1
17*	shaft o-ring	EPDM or Viton®	2
18	retaining ring	SS	1
19	o-ring	EPDM or Viton®	2

* Spare parts available.

infinite adjustable handle kit

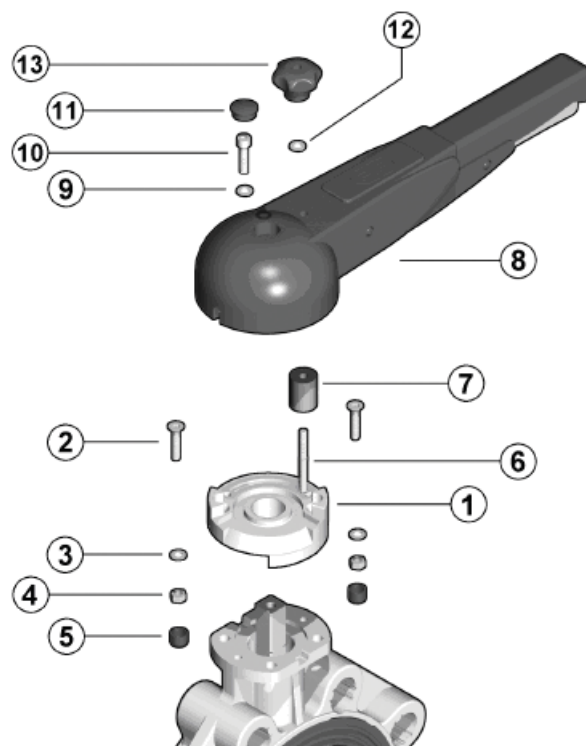

#	Component	Material	Qty
1	pad	GRPP	1
2	screw	SS	2
3	washer	SS	2
4	nut	SS	2
5	cap	PE	2
6	screw	SS	1
7	spacer	PVC	1
8	handle	PVC	1
9	washer	SS	1
10	screw	SS	1
11	cap	PE	1
12	washer	SS	1
13	knob	PP	1

FK Series Butterfly Valves

Installation Procedures

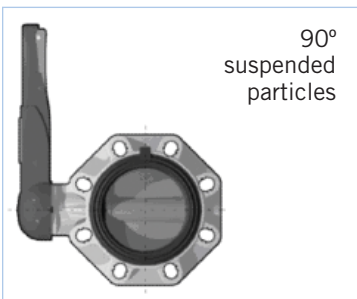
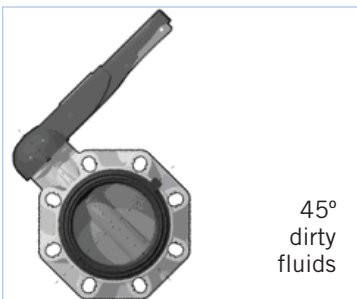
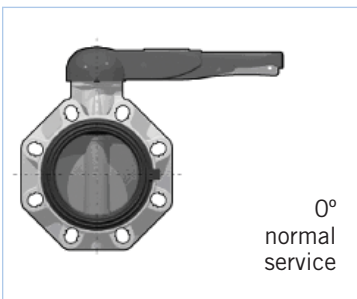
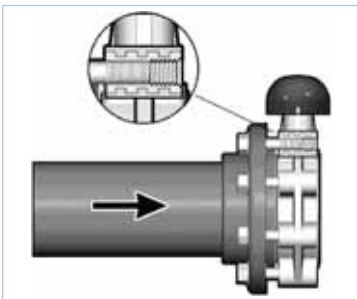
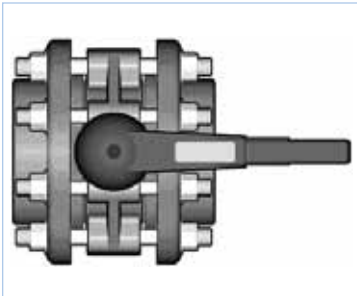

- For the lever handle style, attach the handle (part #2 on previous pages) to the valve body (19) using the supplied bolt (4) and washer (5). Affix the cap (3) over the bolt.
- For non-lugged style sizes 1-1/2" through 8", push the inserts (27) into the body holes according to the position chart below.
- Ensure that the length of the bolts is sufficient for the size of valve being installed. Due to the varying designs of plastic flanges, there is no recommended minimum length. However, a length that results in at least 5 exposed threads on each side should be sufficient.**
- Please refer to the appropriate application sub-section:
 - For typical inline installation, ensure that the disc is in the partially closed position then carefully insert the valve into the piping system between the two flanges. Insert the bolts, washers, and nuts (if necessary), then hand tighten. **Take care to properly line up the valve and flanges as any misalignment may cause leakage.**
 - For lugged version end of line installation, ensure that the disc is in the partially closed position then carefully position the valve on the flange. Insert the bolts, and washers, then hand tighten. **Take care to properly line up the valve and flange as any misalignment may cause leakage.**
- To avoid damage to the primary gasket, cycle the valve to the open position before tightening the bolts. For correct joining procedure, please refer to the section entitled, "Joining Methods – Flanging" in the IPEX Industrial Technical Manual Series, "Volume 1: Vinyl Process Piping Systems". **The bolts should be tightened in an even pattern to the nominal torque in the table below. These torque ratings are sufficient to maintain a watertight seal at the maximum rated operating pressure.**

Note: If the process media is dirty or contains suspended particles, it is advisable to install the valve in an orientation in which the shaft is not vertical (see diagrams). Over time, particles may collect at the bottom of the valve posing a threat to the seal between the disc, liner, and shaft.

Size	ANSI 150 Insert Position	Nominal Bolt Torque ((ft-lbs)
1-1/2	POS 1	7
2	-	9
2-1/2	POS 2	11
3	POS 2	13
4	POS 2	15
5	POS 2	26
6	POS 2	30
8	POS 2	41
10	-	52
12	-	52

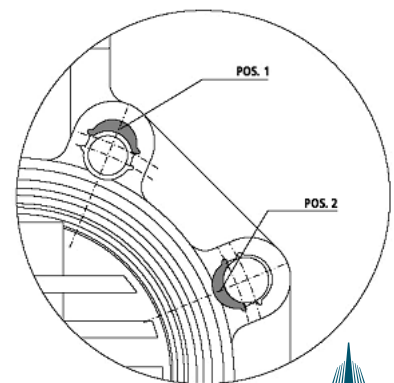

FK Series Butterfly Valves

Valve Maintenance

disassembly



1. If removing the valve from an operating system, isolate the valve from the rest of the system. **Be sure to depressurize and drain the isolated branch before continuing.**
2. Cycle the valve to a partially open position then loosen each bolt holding the valve to the pipe flange(s). Please refer to the section entitled, "Joining Methods – Flanging" in the IPEX Industrial Technical Manual Series, "Volume I: Vinyl Process Piping Systems" for a recommended bolt tightening pattern diagram. Follow the same pattern when disassembling the flanged joint(s) then carefully remove the valve from the line.

Sizes 1-1/2" to 8"

3. For the lever handle style:
 - a. Remove the cap (3) then loosen the screw (4) and washer (5) to remove the handle (2).
 - b. Loosen the screws (7) then remove the washers (11), nuts (12), caps (28), and the pad (10) from the valve body (19).
4. For the mounted gear box style:
 - a. Loosen and remove the bolts and washers fixed to the gear box. Carefully remove the gear box from the valve taking care not to damage the stem.
 - b. Loosen the screws (7) then remove the washers (11), nuts (12), caps (28), and the spacer pad (6) from the valve body (19).
5. Remove the cap (20) then loosen and remove the screw (21) and washer (22) from the base of the valve body.
6. Carefully pull the shaft (14) out of the valve body then remove the disc (25).
7. Remove the primary liner (26) from the valve body.
8. Remove the nylon bushing (16) and o-rings (15) from the valve body (sizes 2-1/2" to 8").
9. Remove the disc anti-friction rings (23), and o-rings (24, sizes 2-1/2" to 8").
10. Remove the retaining ring (13, sizes 2-1/2" to 8") and o-rings (17, 18) from the shaft.
11. The valve components can now be checked for problems and/or replaced.

Sizes 10" to 12"

3. Loosen and remove the bolts and washers fixed to the gear box. Carefully remove the gear box from the valve taking care not to damage the stem.
4. Remove the cap (13) then loosen and remove the screw (14) and washers (11, 12, and 15) from the base of the valve body (1).
5. Carefully pull the shaft (16) out of the valve body then remove the disc (10).
6. Remove the primary liner (7) from the valve body.
7. Remove the upper and lower bushings (3, 5), washers (2, 6), and o-rings (4) from the valve body.
8. Remove the disc anti-friction rings (8) and o-rings (9, 19).
9. Remove the retaining ring (18) and o-rings (17) from the shaft.
10. The valve components can now be checked for problems and/or replaced.



FK Series Butterfly Valves

Valve Maintenance (cont'd)

assembly



Note: Before assembling the valve components, it is advisable to lubricate the o-rings with a water soluble lubricant. **Be sure to consult the "IPEX Chemical Resistance Guide" and/or other trusted resources to determine specific lubricant-rubber compatibilities.**

Sizes 1-1/2" to 8"

1. Insert the primary liner (26) into the valve body (19). **Ensure that the proper holes line up with those on the body.**
2. Properly fit the o-rings (15) on the nylon bushing (16) (sizes 2-1/2" to 8") then insert the Teflon washer and bushing into the valve body from above.
3. Properly fit the disc o-rings (24, sizes 2-1/2" to 8") and anti-friction rings (23) on the disc (25), then insert into the valve liner taking care to center the holes.
4. Properly fit the o-rings (17, 18) and retaining ring (13, sizes 2-1/2" to 8") in their grooves on the shaft (14), then carefully insert into the valve body from above.
5. Fasten the shaft at the base of the valve body using the screw (21) and washer (22). Affix the cap (20) over the bolt.
6. For the lever handle style:
 - a. Place the pad (10) on the valve body then fasten using the screws (7), washers (11), nuts (12), and caps (28).
 - b. Affix the handle (2) using the screw (4), washer (5), and cap (3).
7. For the mounted gear box style:
 - a. Place the spacer pad (6) on the valve body then fasten using the screws (7), washers (11), nuts (12), and caps (28).
 - b. Carefully place the gear box on the stem, lining up the holes. Fasten using the necessary bolts and washers.

Sizes 10" to 12"

1. Insert the primary liner (7) into the valve body (1). **Ensure that the proper holes line up with those on the body.**
2. Properly fit the o-rings (4) on the upper and lower bushings (3, 5) then insert into the valve body from above and below along with the washers (2, 6).
3. Properly fit the disc o-rings (9, 19) and anti-friction rings (8) on the disc (10), then insert into the valve liner taking care to center the holes.
4. Properly fit the o-rings (17) and retaining ring (18) in their grooves on the shaft (16), then carefully insert into the valve body from above.
5. Fasten the shaft at the base of the valve body using the screw (14) and washers (11, 12, and 15). Affix the cap (13) over the bolt.
6. Carefully place the gear box on the stem, lining up the holes. Fasten using the necessary bolts and washers.



FK Series Butterfly Valves

Testing and Operating

sizes
1-1/2" to 2"



sizes
2-1/2" to 8"

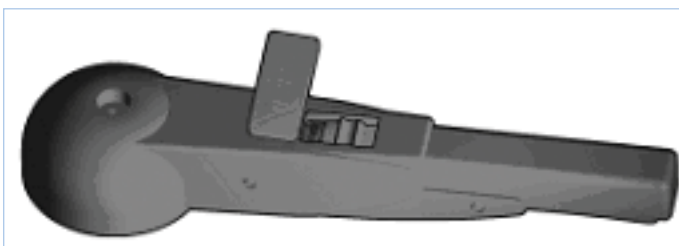

The purpose of system testing is to assess the quality of all joints and fittings to ensure that they will withstand the design working pressure, plus a safety margin, without loss of pressure or fluid. Typically, the system will be tested and assessed in sub-sections as this allows for improved isolation and remediation of potential problems. With this in mind, the testing of a specific installed valve is achieved while carrying out a test of the overall system.

An onsite pressure test procedure is outlined in the IPEX Industrial Technical Manual Series, "Volume I: Vinyl Process Piping Systems" under the section entitled, "Testing". The use of this procedure should be sufficient to assess the quality of a valve installation. **In any test or operating condition, it is important to never exceed the pressure rating of the lowest rated appurtenance in the system.**

Important points:

- Never test thermoplastic piping systems with compressed air or other gases including air-over-water boosters.
- When testing, do not exceed the rated maximum operating pressure of the valve.
- Avoid the rapid closure of valves to eliminate the possibility of water hammer which may cause damage to the pipeline or the valve.

The FK handle incorporates a locking mechanism that prevents unintentional rotation. When engaged, the spring-loaded handle release is locked and the valve cannot be cycled. A padlock can be installed through this portion of the handle as an additional safety precaution.

Please contact IPEX customer service and technical support with regard to any concern not addressed in this data sheet or the technical manual.

FK Series Butterfly Valves

About IPEX

IPEX is a leading supplier of thermoplastic piping systems. We provide our customers with one of the world's largest and most comprehensive product lines. All IPEX products are backed by over 50 years of experience. With state-of-the-art manufacturing facilities and distribution centers across North America, the IPEX name is synonymous with quality and performance.

Our products and systems have been designed for a broad range of customers and markets. Contact us for information on:

- PVC, CPVC, PP, FR-PVDF, ABS, PEX and PE pipe and fittings ($\frac{1}{4}$ " to 48")
- Industrial process piping systems
- Double containment systems
- Acid waste systems
- High purity systems
- Industrial, plumbing and electrical cements
- Municipal pressure and gravity piping systems
- Plumbing and mechanical pipe systems
- Electrical systems
- Telecommunications systems
- Irrigation systems
- PE Electrofusion systems for gas and water
- Radiant heating systems

WARRANTY: All IPEX products are guaranteed against defects resulting from faulty workmanship or materials. If any such product is found to be defective by reason of faulty workmanship or materials, upon written notice and return of the product, the defective product will be replaced by IPEX free of charge, including shipping charges for the replacement product. Claims for labour costs and other expenses required to replace such defective product or to repair any damage resulting from the use thereof will not be allowed by IPEX. Our liability is limited to the price paid for the defective product. IPEX will not be bound by any warranty, other than the above set forth, unless such warranty is in writing.

This literature is published in good faith and is believed to be reliable. However, IPEX does not represent and/or warrant in any manner the information and suggestions contained in this brochure. Data presented is the result of laboratory tests and field experience.

IPEX maintains a policy of ongoing product improvement. This may result in modification of features and/or specifications without notice.

