

VE Series Ball Valves

Product Data Sheet



introduction

< STANDARDS >



ASTM D1784
ASTM D2466
ASTM D2467
ASTM D2464
ASTM D1498



ANSI B1.20.1

IPEX VE Series ball valves are ideal for light industrial and water applications. These valves feature an ultra-compact double block design, and full port bi-directional operation. The true union design allows the valve to be easily removed from the piping system and fully serviced. A threaded seat stop carrier provides improved seal integrity under tough service conditions while the removable handle also functions as a tool for ball seat adjustment. VE Series ball valves are part of our complete systems of pipe, valves, and fittings, engineered and manufactured to our strict quality, performance, and dimensional standards.

Valve Availability

Body Material:	PVC
Size Range:	1/2" through 2"
Pressure:	232 psi
Seats:	Teflon® – HDPE blend
Seals:	EPDM
End Connections:	Socket (IPS), Threaded (FNPT)

VE Series Ball Valves

Sample Specification



1.0 Ball Valves - VE

1.1 Material

- The valve body, stem, ball and unions shall be made of PVC compound which shall meet or exceed the requirements of cell classification 12454 according to ASTM D1784.
- These compounds shall comply with standards that are equivalent to NSF Standard 61 for potable water.

1.2 Seats

- The ball seats shall be made of a Teflon® – HDPE blend which shall comply with standards that are equivalent to NSF Standard 61 for potable water.

1.3 Seals

- The o-ring seals shall be made of EPDM which shall comply with standards that are equivalent to NSF Standard 61 for potable water.

- 1.4 All other wetted and non-wetted parts of the valves shall comply with standards that are equivalent to NSF Standard 61 for potable water.

2.0 Connections

2.1 Socket style

- The IPS socket PVC end connectors shall conform to the dimensional standards ASTM D2466 and ASTM D2467.

2.2 Threaded style

- The female NPT threaded PVC end connectors shall conform to the dimensional standards ASTM D2464, ASTM F1498, and ANSI B1.20.1.

3.0 Design Features

- The valve shall be double blocking with union ends.
- All sizes shall be full port.
- All sizes shall allow for bi-directional flow.
- The valve body shall be single end entry with a threaded carrier (ball seat support).
- The valve body shall have an expansion and contraction compensating groove on the molded end.
- The valve body, union nuts, and carrier shall have deep square style threads for increased strength.
- The ball shall be machined smooth to minimize wear on valve seats.



VE Series Ball Valves

Sample Specification (cont'd)



- The stem design shall feature a shear point above the o-ring to maintain system integrity in the unlikely event of a stem breakage.
- The handle shall incorporate a tool for adjustment of the threaded carrier.
- The handle shall be reversible to allow for operation in tight places.

3.1 Pressure Tested

- All valves shall have been pressure tested in both the open and closed positions by the manufacturer.

3.2 Pressure Rating

- All sizes shall be rated at 232 psi at 73°F.

3.3 Markings

- All valves shall be marked to indicate size, material designation, and manufacturer's name or trade mark.

3.4 Color Coding

- All PVC valves shall be color-coded dark gray with a blue handle.

4.0 All valves shall be Xirtec® 140 by IPEX or approved equal.

VE Series Ball Valves

Valve Selection



Size (inches)	Body Material	O-ring Material	IPEX Part Number		Pressure Rating
			IPS Socket	FNPT Threaded	
1/2	PVC	EPDM	053373	053374	232 psi
3/4			053124	053215	
1			053125	053217	
1-1/4			053126	053219	
1-1/2			053127	053220	
2			053128	053221	

Size (inches):

- 1/2 1-1/4
- 3/4 1-1/2
- 1 2

End Connections:

- Socket (IPS)
- Threaded (FNPT)

IPEX Part Number:

VE Series Ball Valves

Technical Data



dimensions

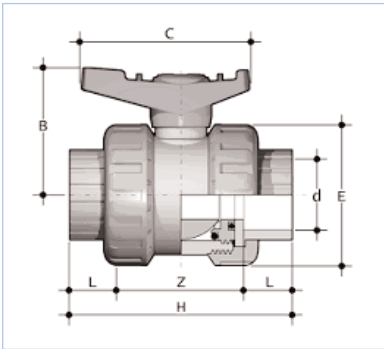

Size	Dimension (inches)						
	d	L	Z	H	E	B	C
1/2	0.84	0.89	2.01	3.78	2.09	1.97	2.56
3/4	1.05	1.00	2.13	4.13	2.44	2.28	2.99
1	1.32	1.13	2.34	4.61	2.80	2.56	3.35
1-1/4	1.66	1.26	2.83	5.35	3.31	2.99	3.94
1-1/2	1.90	1.38	3.03	5.79	3.86	3.35	4.41
2	2.38	1.50	3.84	6.85	4.61	4.06	5.39

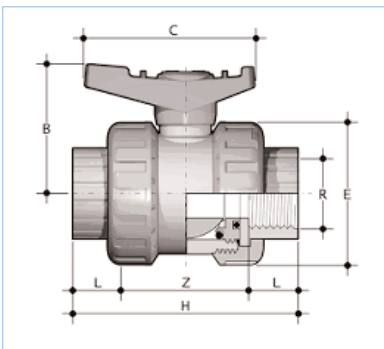

Size	Dimension (inches)						
	R	L	Z	H	E	B	C
1/2	1/2-NPT	0.70	2.14	3.54	2.09	1.97	2.56
3/4	3/4-NPT	0.71	2.24	3.66	2.44	2.28	2.99
1	1-NPT	0.89	2.55	4.33	2.80	2.56	3.35
1-1/4	1-1/4-NPT	0.99	3.02	5.00	3.31	2.99	3.94
1-1/2	1-1/2-NPT	0.97	3.21	5.16	3.86	3.35	4.41
2	2-NPT	1.17	4.01	6.34	4.61	4.06	5.39

VE Series Ball Valves

Technical Data (cont'd)

weights



Size (inches)	Approximate Weight (lbs)	
	PVC	
	IPS Socket	FNPT Threaded
1/2	0.32	0.32
3/4	0.49	0.49
1	0.69	0.69
1-1/4	1.11	1.11
1-1/2	1.60	1.60
2	2.74	2.74

pressure – temperature ratings

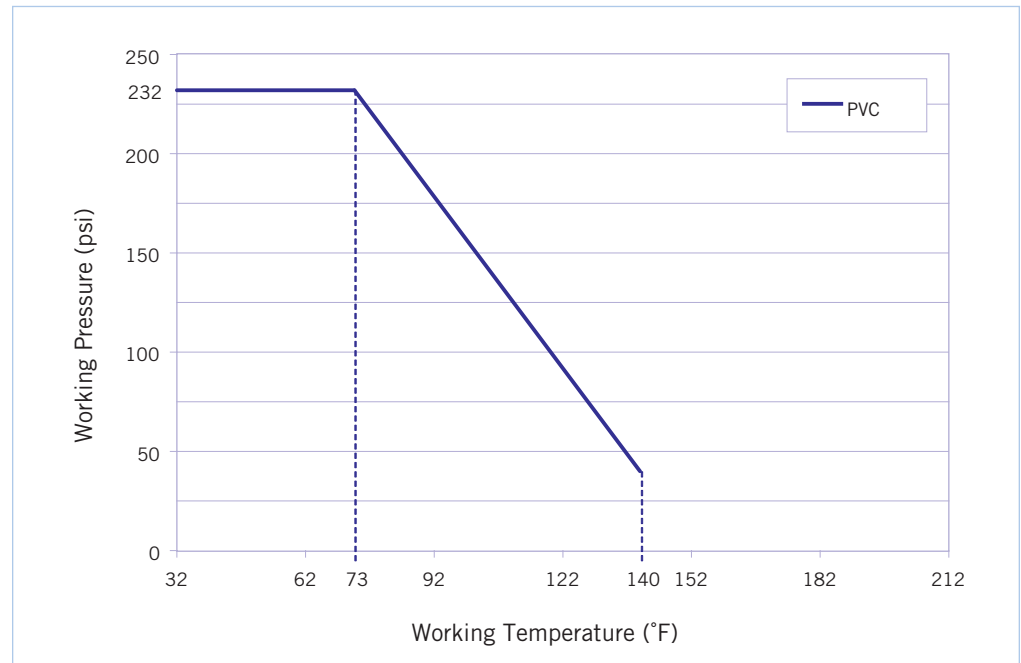

VE Series Ball Valves

Technical Data (cont'd)



flow coefficients

The flow coefficient (CV) represents the flow rate in gallons per minute (GPM) at 68°F for which there is a 1 psi pressure drop across the valve in the fully open position. These values are determined from an industry standard testing procedure which uses water as the flowing media (specific gravity of 1.0). To determine specific flow rate and pressure loss scenarios, one can use the following formula:

$$f = sg \times \left(\frac{Q}{C_v} \right)^2$$

Where,

f is the pressure drop (friction loss) in psi,

sg is the specific gravity of the fluid,

Q is the flow rate in GPM,

C_v is the flow coefficient.

Size	CV
1/2	14.0
3/4	27.0
1	53.9
1-1/4	77.0
1-1/2	123
2	238

pressure loss chart

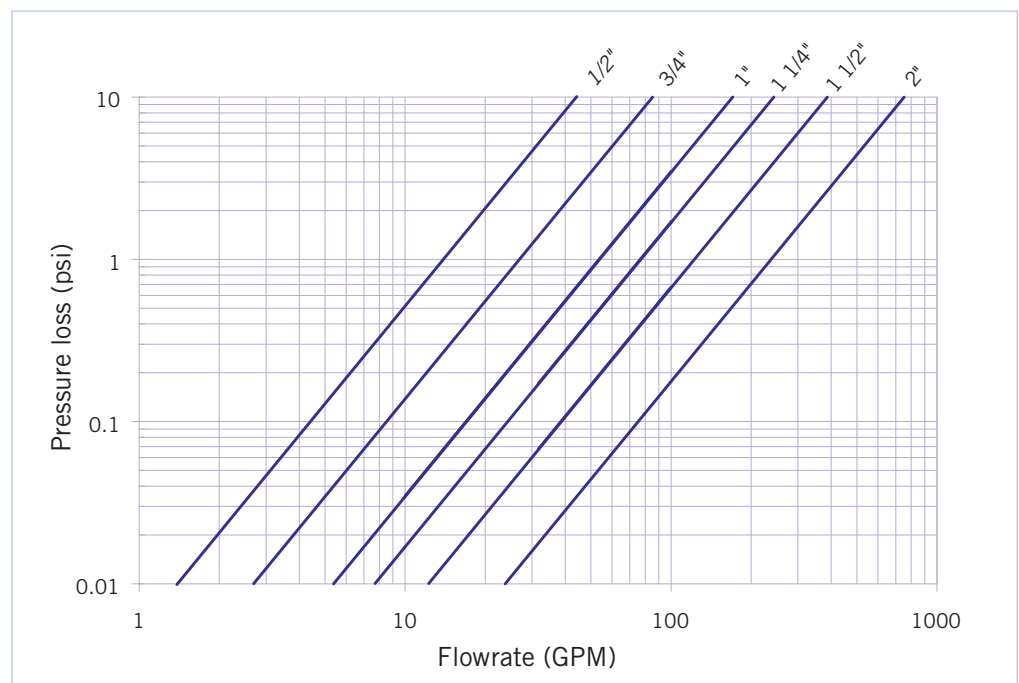

VE Series Ball Valves

Components

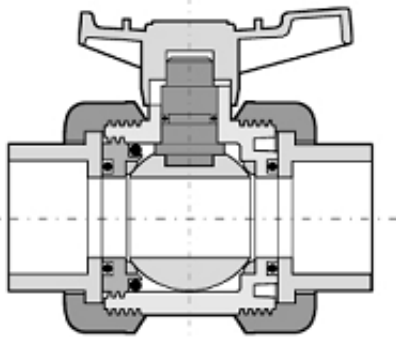
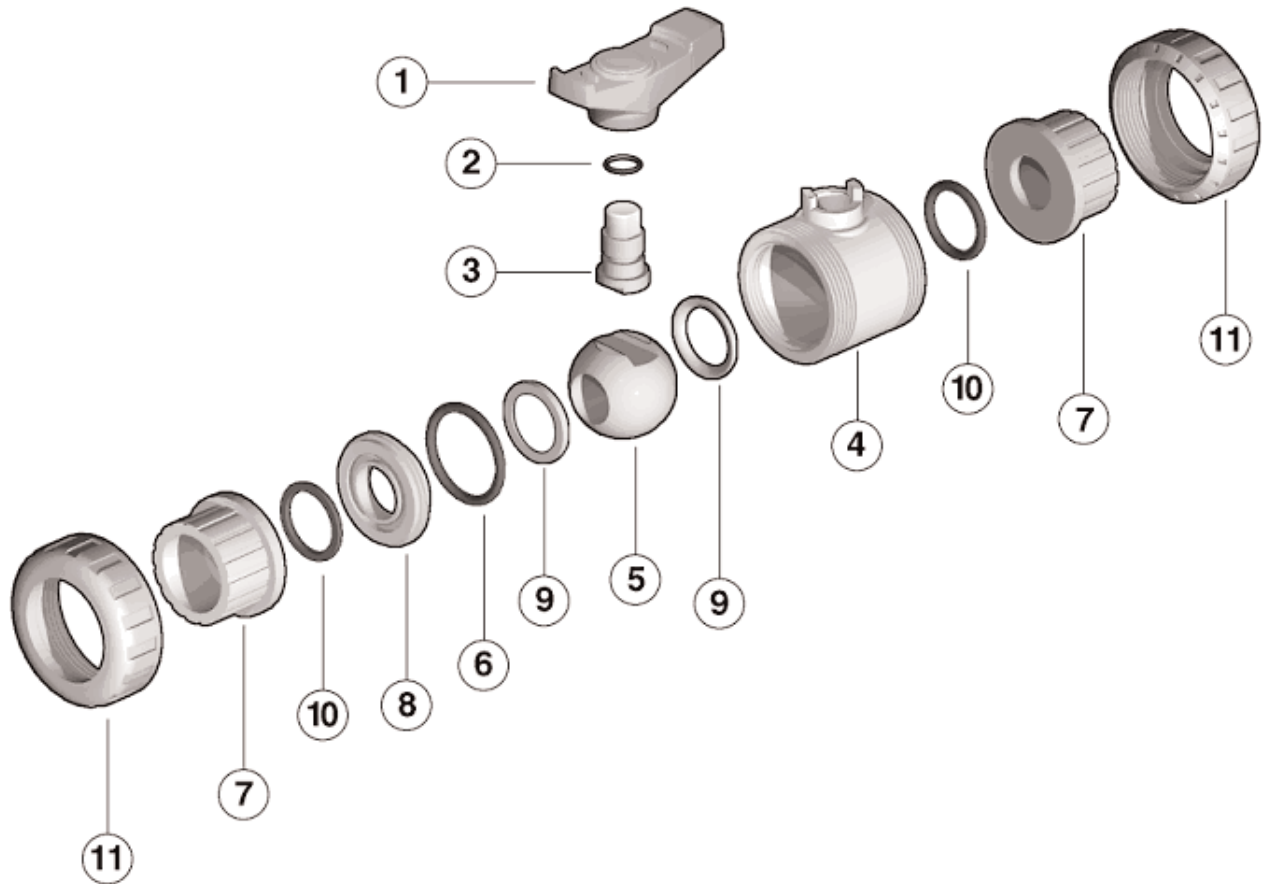

#	Component	Material	Qty
1	handle	High Impact PVC	1
2	stem o-ring	EPDM	1
3	stem	PVC	1
4	body	PVC	1
5	ball	PVC	1
6	body o-ring	EPDM	1
7	end connector	PVC	2
8	support for ball seat	PVC	1
9	ball seat	PTFE – HDPE blend	2
10	socket o-ring	EPDM	2
11	union nut	PVC	2

VE Series Ball Valves

Installation Procedures



1. Remove the union nuts (part #11 on previous page) and slide them onto the pipe.
2. Please refer to the appropriate connection style sub-section:
 - a. For socket style, solvent cement the end connectors (7) onto the pipe ends. For correct joining procedure, please refer to the section entitled, *“Joining Methods – Solvent Cementing”* in the IPEX Industrial Technical Manual Series, *“Volume I: Vinyl Process Piping Systems”*. **Be sure to allow sufficient cure time before continuing with the valve installation.**
 - b. For threaded style, thread the end connectors (7) onto the pipe ends. For correct joining procedure, please refer to the section entitled, *“Joining Methods – Threading”* in the IPEX Industrial Technical Manual Series, *“Volume I: Vinyl Process Piping Systems”*.
3. Open and close the valve to ensure that the ball seat support (8) is at the desired adjustment. If adjustment is required, ensure that the valve is in the closed position then remove the handle (1) from the valve stem. Line up the moldings on the handle with the slots in the ball seat support. Tighten or loosen to the desired position then replace the handle on the valve stem.
4. Ensure that the valve is in the closed position, and that the socket o-rings (10) are properly fitted in their grooves. Carefully place the valve in the system between the two end connections.
5. Tighten the union nut on the side **opposite** to that which is marked “ADJUST”. Hand tightening is typically sufficient to maintain a seal for the maximum working pressure. **Over-tightening may damage the threads on the valve body and/or the union nut and may even cause the union nut to crack.**
6. Tighten the union nut on the side marked “ADJUST”. Tightening the union nuts in this order results in the best possible valve performance due to optimum positioning and sealing of the ball and seat support system.
7. Open and close the valve to again ensure that the cycling performance is adequate. If adjustment is required, place the valve in the closed position, loosen the union nuts, remove the valve from system and then continue from Step 3.

VE Series Ball Valves

Valve Maintenance

disassembly



1. If removing the valve from an operating system, isolate the valve from the rest of the system. **Be sure to depressurize and drain the isolated branch and valve before continuing.**
2. Loosen both union nuts (11) and drop the valve out of the line. If retaining the socket o-rings (10), take care that they are not lost when removing the valve from the line.
3. To disassemble, place the valve in the closed position then remove the handle (1) from the valve stem.
4. Line up the moldings on the handle with the slots in the ball seat support (found on the side marked "ADJUST"). Loosen and remove the ball seat support (8) by turning in a counterclockwise direction.
5. Carefully press the ball (5) out of the valve body, taking care not to score or damage the outer surface.
6. To remove the stem (3), press it into the valve body (4) from above.
7. The stem o-ring (2), body o-ring (6), and ball seats (9) can now be removed and/or replaced.

assembly



Note: Before assembling the valve components, it is advisable to lubricate the o-rings with a water soluble lubricant. **Be sure to consult the "IPEX Chemical Resistance Guide" and/or other trusted resources to determine specific lubricant-rubber compatibilities.**

1. Firmly place the ball seat (9) in the groove on the opposite end inside the valve body (4).
2. Properly fit the stem o-ring (2) in the groove on the stem (3), then insert the stem from the inside of the valve body.
3. Ensure that the valve stem is in the closed position then insert the ball (5) into the valve body taking care not to score or damage the outer surface.
4. Check that the ball seat (9) and body o-ring (6) are properly fitted on the ball seat support (8), then slightly hand tighten into the valve body. Line up the moldings on the handle (1) with the slots in the ball seat support then tighten by turning in a clockwise direction.
5. Replace the handle on the valve stem then cycle the valve open and closed to determine whether or not the performance is adequate. If so desired, the handle can be removed and used to make further adjustments.
6. Properly fit the socket o-rings (10) in their respective grooves.
7. Place the end connectors (7) into the union nuts (11), then thread onto the valve body taking care that the socket o-rings remain properly fitted in their grooves.

VE Series Ball Valves

Testing and Operating



The purpose of system testing is to assess the quality of all joints and fittings to ensure that they will withstand the design working pressure, plus a safety margin, without loss of pressure or fluid. Typically, the system will be tested and assessed in sub-sections as this allows for improved isolation and remediation of potential problems. With this in mind, the testing of a specific installed valve is achieved while carrying out a test of the overall system.

An onsite pressure test procedure is outlined in the IPEX Industrial Technical Manual Series, *“Volume I: Vinyl Process Piping Systems”* under the section entitled *“Testing”*. The use of this procedure should be sufficient to assess the quality of a valve installation. **In any test or operating condition, it is important to never exceed the pressure rating of the lowest rated appurtenance in the system.**

Important points:

- Never test thermoplastic piping systems with compressed air or other gases including air-over-water boosters.
- When testing, do not exceed the rated maximum operating pressure of the valve.
- Avoid the rapid closure of valves to eliminate the possibility of water hammer which may cause damage to the pipeline or the valve.

Please contact IPEX customer service and technical support with regard to any concern not addressed in this data sheet or the technical manual.

VE Series Ball Valves

About IPEX

IPEX is a leading supplier of thermoplastic piping systems. We provide our customers with one of the world's largest and most comprehensive product lines. All IPEX products are backed by over 50 years of experience. With state-of-the-art manufacturing facilities and distribution centers across North America, the IPEX name is synonymous with quality and performance.

Our products and systems have been designed for a broad range of customers and markets. Contact us for information on:

- PVC, CPVC, PP, FR-PVDF, ABS, PEX and PE pipe and fittings ($\frac{1}{4}$ " to 48")
- Industrial process piping systems
- Double containment systems
- Acid waste systems
- High purity systems
- Industrial, plumbing and electrical cements
- Municipal pressure and gravity piping systems
- Plumbing and mechanical pipe systems
- Electrical systems
- Telecommunications systems
- Irrigation systems
- PE Electrofusion systems for gas and water
- Radiant heating systems

WARRANTY: All IPEX products are guaranteed against defects resulting from faulty workmanship or materials. If any such product is found to be defective by reason of faulty workmanship or materials, upon written notice and return of the product, the defective product will be replaced by IPEX free of charge, including shipping charges for the replacement product. Claims for labour costs and other expenses required to replace such defective product or to repair any damage resulting from the use thereof will not be allowed by IPEX. Our liability is limited to the price paid for the defective product. IPEX will not be bound by any warranty, other than the above set forth, unless such warranty is in writing.

This literature is published in good faith and is believed to be reliable. However, IPEX does not represent and/or warrant in any manner the information and suggestions contained in this brochure. Data presented is the result of laboratory tests and field experience.

IPEX maintains a policy of ongoing product improvement. This may result in modification of features and/or specifications without notice.

