



KEROTEST

EV-11
Soft-Seated Valves

Kerotest EV-11 Soft-Seated Valve

Natural Gas Valve

EV-11 Soft-Seated Valve Delivers State-of-the-Art Performance

The Soft-Seated EV-11 Valve was developed in response to an industry request to design an inexpensive valve that solved the common problems inherent in standard gate valves and lubricated plug valves.

The innovative EV-11 Valve design eliminated the lower body cavity common to traditional gate valves. The bubble-tight seal and no-cavity design eliminated the "build-up" of tramp materials and ice in the body cavity.

The EV-11 full bore design also provided for minimal pressure drop through the valve, solving the reduced-port problem associated with standard plug valves.

Industry embraced the innovative EV-11 Soft-Seated Valve. Today, applications for the valve include general use with both natural gas distribution and transmission companies, liquid pipelines, and industry.

Kerotest's EV-11 Soft-Seated Valve requires no lubrication, making it an excellent choice upstream of meters and regulators.



Unique Design Provides Bubble-Tight Shut-off



The EV-11 features a unique rubber seal compatible with most gas and liquid applications employing a simple seat sealing concept which eliminates traditional body seats and lubricants, while providing bubble-tight shut-off.

The EV-11 is sealed by a rubber seal which surrounds the top and sides of the gate. A metal reinforcement band within the rubber secures the seal within the gate as it seals both the bore and neck of the valve against leakage across the gate.

The gate is guided into the closed position by means of integral guides on the gate which straddle a web cast into the body. Thus, the body serves as a sealing surface.

The valve body has a smooth, round bottom with no cavity to accumulate debris which could impair the movement of the gate. Also, with no cavities, there is no place for condensate to accumulate. Thus, the possibility of freezing is eliminated.



Kerotest Manufacturing Corp.

5500 Second Avenue
Pittsburgh, PA 15207

Phone: 412-521-7263 Fax: 412-521-5990

Kerotest EV-11 Soft-Seated Valve

Natural Gas Valve

How the Soft-Seated Valve Works

Upon closing the valve, the thrust of the stem forces the spreader to compress the rubber seal outward against the body. This action provides a bubble-tight seal around the neck and bore of the valve.



Stem Seal

The stem is of 400 Series Stainless Steel for added corrosion resistance, and is sealed with a bronze bushing which features double "O" rings. This stem seal eliminates leakage and reduces operating torque for ease of actuation.

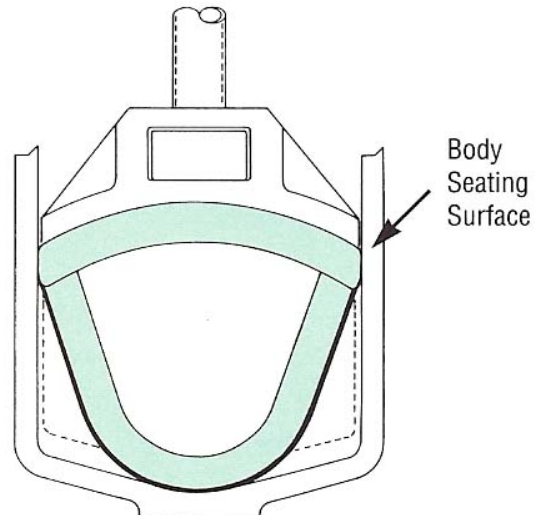
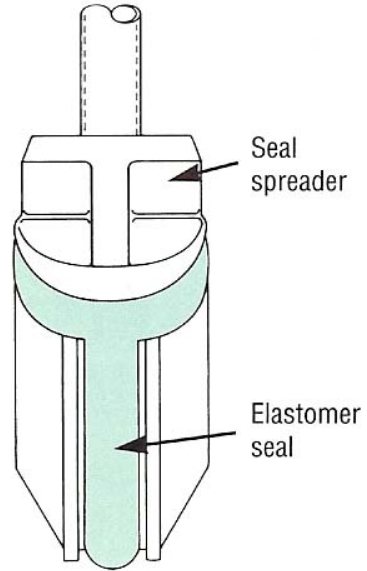
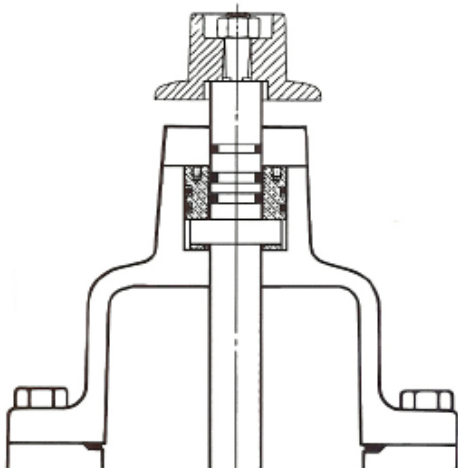

Stem torque forces compression of elastomer seal.

Soft elastomer seal compresses against body seating surface, effectively sealing the valve bore.



Kerotest Manufacturing Corp.

5500 Second Avenue
Pittsburgh, PA 15207

Phone: 412-521-7263 Fax: 412-521-5990

Kerotest EV-11 Soft-Seated Valve

Natural Gas Valve

2" through 12" - Full Port Class 150, 500# WOG, Class 300, End Connections - Flanged, Weld and Weld by Flanged Ends

The Kerotest EV-11 Soft-Seated Valve is an economical field-proven, full opening, non-rising stem gate valve.

This unusual gate valve incorporates an exclusive "elastomer seat" seat design - a simple method which solves leakage problems without requiring lubrication or conventional seat inserts.

This remarkable general service valve is ideal for natural gas distribution applications including manifolds, flow lines, regulator stations, and meter runs. The full-opening, uncomplicated design of the EV-11 "soft-seat" gate valve makes it ideal for water, oil and other liquid applications.

The unique design incorporated in the Kerotest EV-11 Soft-Seated Valve was originally patented in Europe. Introduced into the U.S. market in the 1970's, the EV-11 won swift, virtually immediate, acceptance. Kerotest has continued the refinement of this proven design. Today's EV-11 embodies three decades of accumulated knowledge in design and materials.

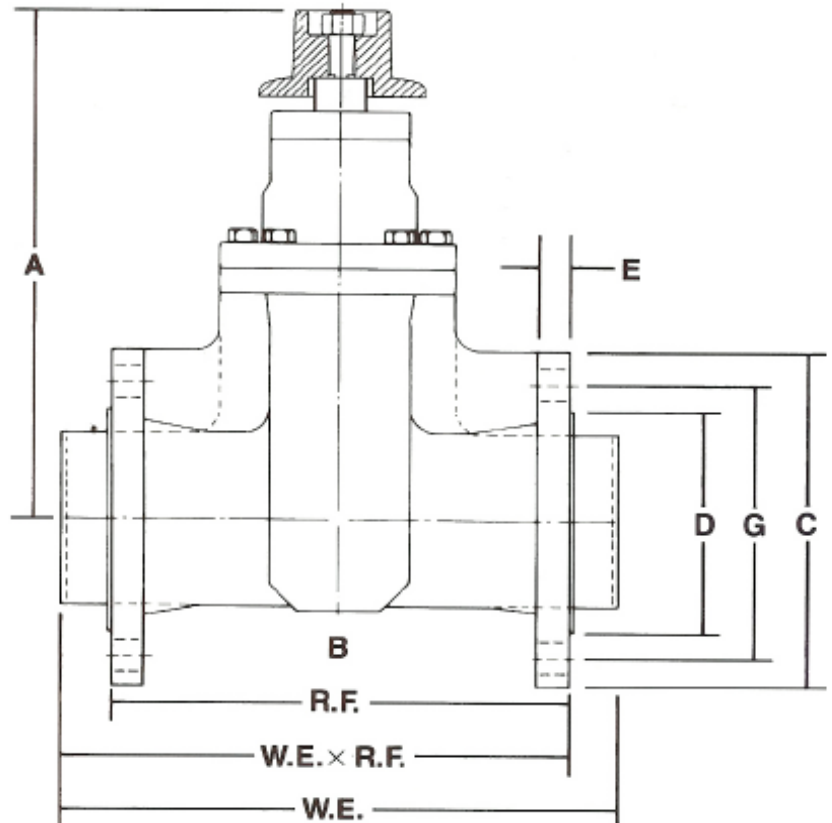
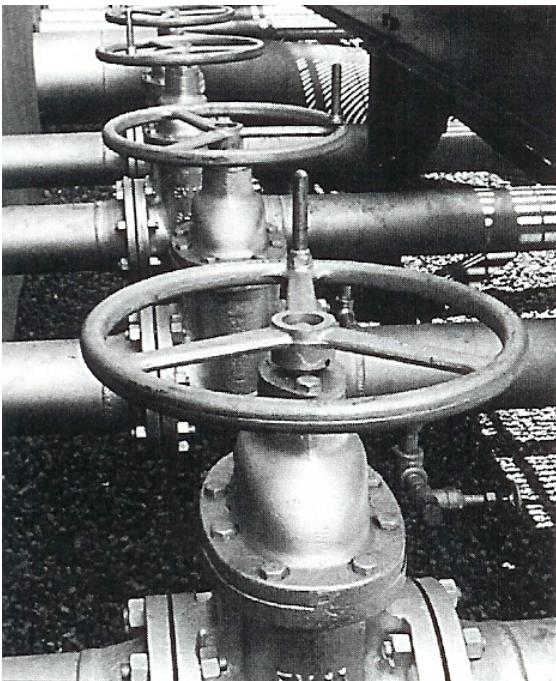

Kerotest Manufacturing Corp.

5500 Second Avenue

Pittsburgh, PA 15207

Phone: 412-521-7263

Fax: 412-521-5990

Kerotest EV-11 Soft-Seated Valve

Natural Gas Valve

Class 150 – 285 MOP (Face to face per ANSI B16.5 and B16.10 CL 150)

Size	A	B* Fig.	B* W.E.	B* W.E.x Fig.	C	D	E*	Bore	G	Bolt Hole Diam.	No. Of Bolts	Hand Wheel O.D.	Wgt Fig.	Wgt W.E.	Wgt W.E.x Fig.	Turn To Close
2	9-3/4	7	8-1/2	7-3/4	6	3-5/8	3/4	2	4-3/4	3/4	4	8	33	22	28	12
3	12-1/8	8	11-1/8	9-9/16	7-1/2	5	15/16	3	6	3/4	4	12	60	46	51	14-1/2
4	13-3/4	9	12	10-1/2	9	6-3/16	15/16	4	7-1/2	3/4	8	12	79	61	70	18-1/2
6	18-1/2	10-1/2	15-7/8	13-3/16	11	8-1/2	1	6	9-1/2	7/8	8	16	166	140	160	20-1/4 †
8	22-3/8	11-1/2	16-1/2	14	13-1/2	10-5/8	1-1/8	8	11-3/4	7/8	8	16	308	278	291	25-3/4 †
10	27-1/4	13	18	15-1/2	16	12-3/4	1-3/16	10	14-1/4	1	12	20	644	500	572	32-1/2
12	30-3/4	14	19-3/4	16-7/8	19	15	1-1/4	12	17	1	12	24	760	687	724	38-1/2
16	30-3/4	---	47-7/8	---	---	---	---	12	---	---	---	---	---	837	---	38-1/2

500 WOG (Face to face per ANSI B16.5 and B16.10 CL 300)

Size	A	B* Fig.	B* W.E.	B* W.E.x Fig.	C	D	E*	Bore	G	Bolt Hole Diam.	No. Of Bolts	Hand Wheel O.D.	Wgt Fig.	Wgt W.E.	Wgt W.E.x Fig.	Turn To Close
2	9-3/4	8-1/2	8-1/2	8-1/2	6-1/2	3-5/8	7/8	2	5	3/4	8	8	36	23	30	12
3	12-1/8	11-1/8	11-1/8	11-1/8	8-1/4	5	1-1/8	3	6-5/8	7/8	8	12	72	47	58	14-1/4
4	13-3/4	12	12	12	10	6-3/16	1-1/4	4	7-7/8	7/8	8	12	99	62	79	18-1/2
6	18-1/2	15-7/8	15-7/8	15-7/8	12-1/2	8-1/2	1-7/16	6	10-5/8	7/8	12	16	200	143	178	20-1/4 †
8	22-3/8	16-1/2	16-1/2	16-1/2	15	10-5/8	1-5/8	8	13	1	12	16	375	278	335	25-3/4 †
10	27-1/4	18	18	18	17-1/2	12-3/4	1-7/8	10	15-1/4	1-1/8	16	20	689	500	599	32-1/2
12	30-3/4	19-3/4	19-3/4	19-3/4	20-1/2	15	2	12	17-3/4	1-1/4	16	24	900	687	785	38-1/2
16	30-3/4	---	47-7/8	---	---	---	---	12	---	---	---	---	---	837	---	38-1/2

Class – 300 740 MOP (Face to face per ANSI B16.5 and B16.10 CL 300)

Size	A	B* Fig.	B* W.E.	B* W.E.x Fig.	C	D	E*	Bore	G	Bolt Hole Diam.	No. Of Bolts	Hand Wheel O.D.	Wgt Fig.	Wgt W.E.	Wgt W.E.x Fig.	Turn To Close
2	9-3/4	8-1/2	8-1/2	8-1/2	6-1/2	3-5/8	7/8	2	5	3/4	8	8	36	23	30	12
3	12-1/8	11-1/8	11-1/8	11-1/8	8-1/4	5	1-1/8	3	6-5/8	7/8	8	12	72	47	58	14-1/4
4	13-3/4	12	12	12	10	6-3/16	1-1/4	4	7-7/8	7/8	8	12	99	62	79	18-1/2
6	18-1/2	15-7/8	15-7/8	15-7/8	12-1/2	8-1/2	1-7/16	6	10-5/8	7/8	12	16	200	143	178	20-1/4 †
8	22-3/8	16-1/2	16-1/2	16-1/2	15	10-5/8	1-5/8	8	13	1	12	16	375	278	335	25-3/4 †
10	27-1/4	18	18	18	17-1/2	12-3/4	1-7/8	10	15-1/4	1-1/8	16	20	689	500	599	32-1/2
12	30-3/4	19-3/4	19-3/4	19-3/4	20-1/2	15	2	12	17-3/4	1-1/4	16	24	900	687	785	38-1/2
16	30-3/4	---	47-7/8	---	---	---	---	12	---	---	---	---	---	837	---	38-1/2

*B (Fig. & W.E.x Fig.) and E dimensions include 1/16 inch raised face thickness.

† Valves produced prior to 1986 will have single ACME stem threads and the number of turns will be double.

Note: Class 150 & 300 Valves built prior to the July 10, 2006 change to the Federal Code Part 192 are rated as follows: Class 150 -275 MOP, Class 300 – 720 MOP

When Ordering, please specify valve size, end configuration pressure rating.



Kerotest Manufacturing Corp.
 5500 Second Avenue
 Pittsburgh, PA 15207
 Phone: 412-521-7263 Fax: 412-521-5990

Kerotest EV-11 Soft-Seated Valve

Natural Gas Valve

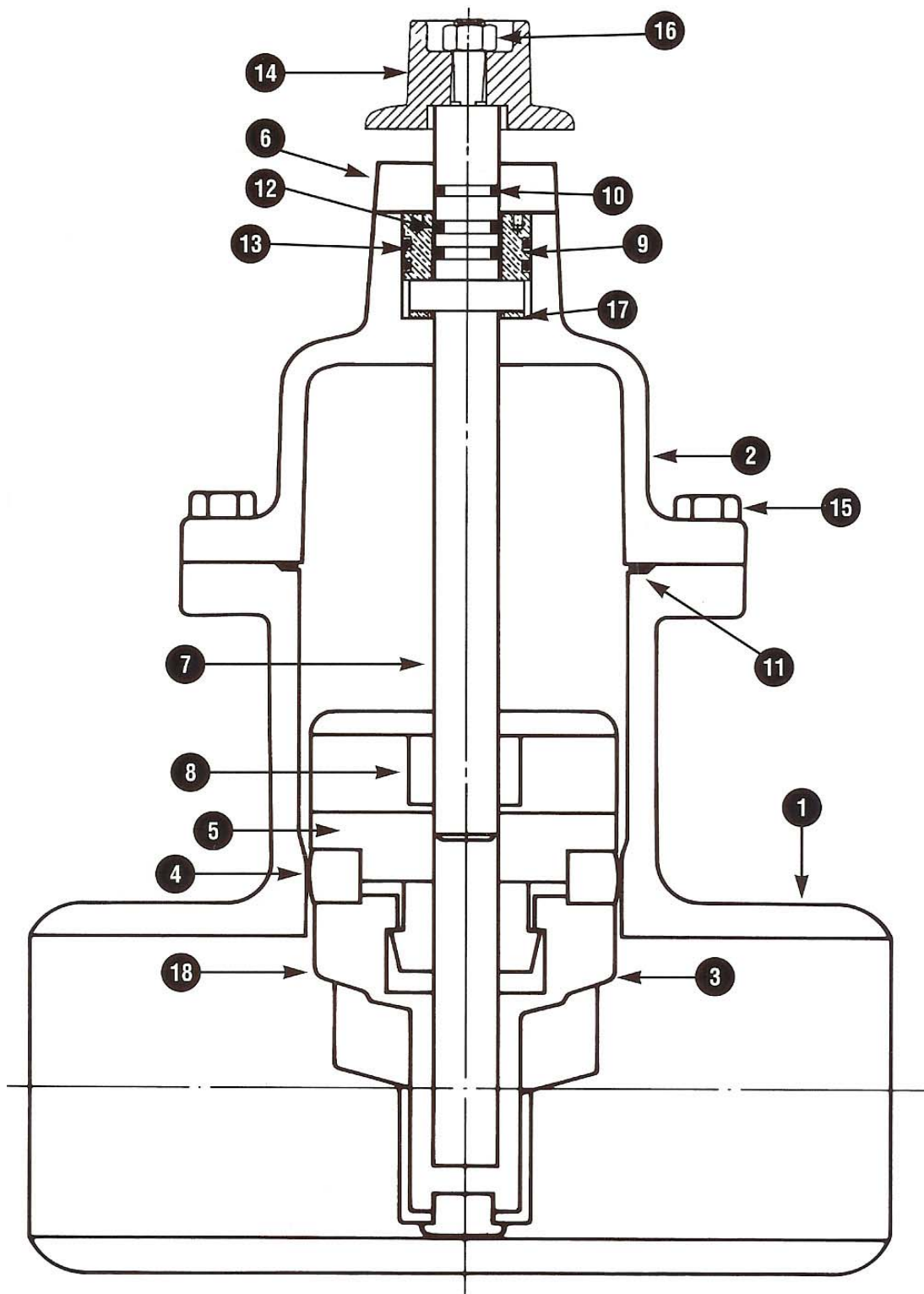

www.kerotest.com

Kerotest Manufacturing Corp.

5500 Second Avenue
Pittsburgh, PA 15207

Phone: 412-521-7263 Fax: 412-521-5990

Kerotest EV-11 Soft-Seated Valve

Natural Gas Valve

Item Number	Name of Part	Description of Material
1	Body	Steel, ASTM A216, Grade WCB
2	Bonnet	Steel, ASTM A216, Grade WCB
3	Gate Segments	Ductile Iron
4	Seal Member (Stirrup)	Buna-N / Viton
5	Spreader	Ductile Iron
6	Gland Bushing Retainer	Steel
7	Stem	400 Series Stainless Steel
8	Stem Nut	Manganese Bronze
9	Gland Bushing	Bronze
10	Stem Wiper "O" Ring	Buna-N / Viton
11	Bonnet "O" Ring	Buna-N / Viton
12	Stem Seal "O" Ring	Buna-N / Viton
13	Bushing Seal "O" Ring	Buna-N / Viton
14	Operating Square	Ductile Iron
15	Bonnet Cap Screw	Alloy Steel, SAE Grade 8
16	Hex Nut	Carbon Steel Plated
17	Thrust Washer	Brass
18	Gate Cap Screw	Alloy Steel

NOTE: Spreader and Stem Nut are combined in a 2" valve.



Kerotest Manufacturing Corp.

5500 Second Avenue

Pittsburgh, PA 15207

Phone: 412-521-7263

Fax: 412-521-5990

Kerotest EV-11 Soft-Seated Valve

Natural Gas Valve

Soft-Seated Valve Suitable for Numerous Applications

*General valve requirements for bubble-tight shutoff

*Natural gas distribution

block valves

regulator stations

meter sets

hot tapping applications

*Natural gas transmissions

pipeline valving

regulator stations

compressor stations

*Liquid pipeline valving

*Industrial applications

*Water service

*Slurry pipelines

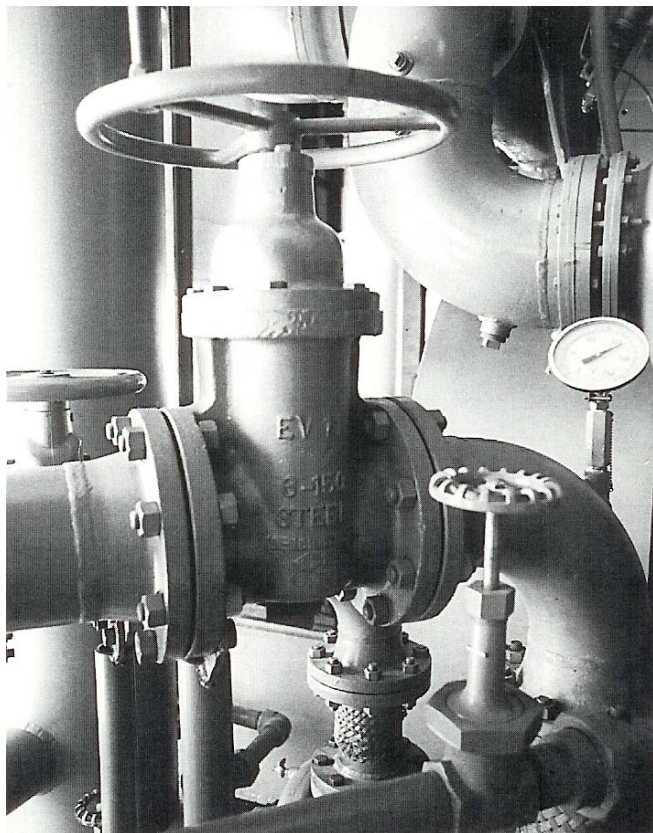

Options Customize Valve to Application

- Handwheel in lieu of 2 inch operating nut
- Locking device
- Position indicator
- Viton trim
- Stem drive extensions
- Protective coatings
- Coded transition end connections

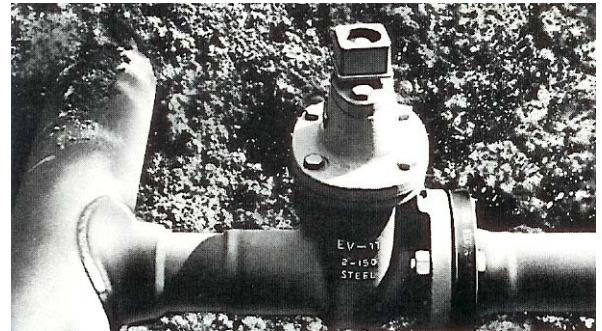

EV-11 Offers Multiple Features and Benefits:

- Bubble-tight shut-off, despite particles and scale
- Full Opening ---- providing minimum pressure drop
- No metal-to-metal contact between gate sealing members
- Hot tapping. Will pass all tools, cutters and cuttings
- Maintenance free
- No lubrication required
- Field serviceable



Kerotest Manufacturing Corp.

5500 Second Avenue

Pittsburgh, PA 15207

Phone: 412-521-7263

Fax: 412-521-5990