



SVF Series L8 ball valves are compression-ended valves that are designed to be compatible with all of the leading instrument fittings. This high performance valve has all of the key features of our process-quality design.

FEATURES

1/4 - 1"

- Live-loaded stem seal as per ISA-SP-93
- Encapsulated body seals to facilitate inline weldability without disassembly
- Self-relieving seats that reduce operating torque and improve seat life
- Integral ISO mounting pad to ISO-5211
- Stainless steel ends are 316L grade
- Blowout-proof stem
- Stainless externals - hardware, stem and handle
- Full Range of versatile options

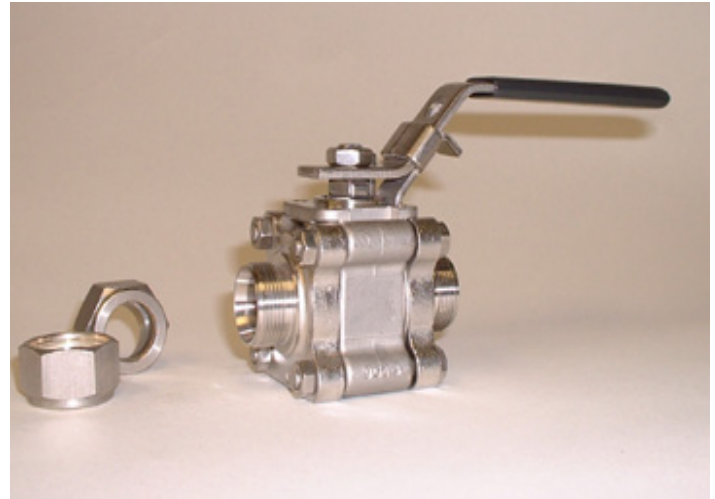

MATERIALS

| Item | Description | Material |
|------|---------------------|---|
| 1 | Body | 316 Stainless |
| 2 | Body Connector | 316 Stainless |
| 3 | Ball | 316 Stainless |
| 4 | Stem | 316 Stainless |
| 5 | Valve Seat | TFE, Reinforced TFE, NRG, Delrin, UHMWPE, PEEK, VXI |
| 5A | Cavity Filled Seat | TFE |
| 6 | Body Connector Seal | TFE, Graphoil, Buna "N", UHMWPE |

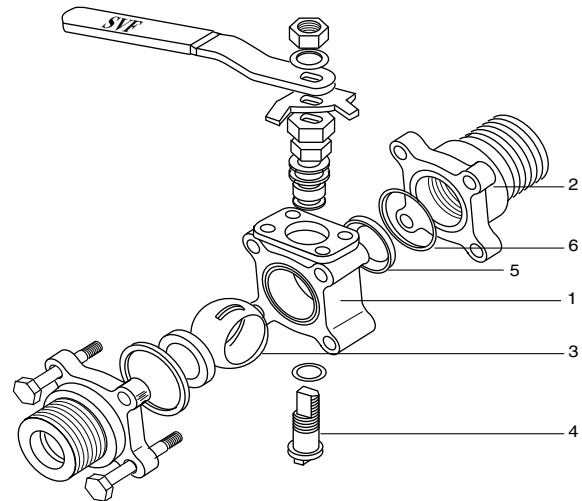

DIMENSIONS & WEIGHTS (ins., lbs.)

| Size | A | B | C | E | weight (lbs) |
|------|------|------|------|------|--------------|
| 1/4" | 3.03 | 2.40 | 4.49 | 1.81 | 1.7 |
| 3/8" | 3.11 | 2.40 | 4.49 | 1.81 | 1.7 |
| 1/2" | 3.35 | 2.40 | 4.49 | 1.81 | 1.7 |
| 3/4" | 3.74 | 2.60 | 4.49 | 1.87 | 2.0 |
| 1" | 4.53 | 3.42 | 5.75 | 2.40 | 3.7 |

