



TITAN FLOW CONTROL, INC.

## SWING CHECK VALVE ♦ WAFER TYPE ♦ SINGLE DISC

### ANSI CLASS 150 ♦ DUCTILE IRON

# MODEL: CV 31-DI

Body: Ductile Iron  
 Seat: Buna-N  
 Disc: Stainless Steel



## FEATURES

SIZES: 2" ~ 12"

- ♦ **ECONOMICAL DESIGN**  
 LOW WEIGHT AND SHORT LAYING LENGTH PRODUCE SAVINGS IN INITIAL COST, SPACE REQUIREMENTS, AND INSTALLATION WHEN COMPARED TO FULL-BODY, SWING-TYPE CHECK VALVES.
- ♦ **MINIMAL HEAD LOSS**  
 HEAD LOSS IS MINIMIZED BY PROVIDING A SHORT, STRAIGHT AND VIRTUALLY UNOBSTRUCTED FLOW PATH. ADDITIONALLY, THE SPRING-LOADED DISC IS DESIGNED WITH VERY LOW CRACKING PRESSURE WHICH REDUCES THE AMOUNT OF ENERGY REQUIRED TO OPEN THE VALVE.
- ♦ **QUICK CLOSURE TO REDUCE WATER HAMMER**  
 SHUT-OFF IS ACHIEVED VIA THE FULLY AUTOMATIC, SPRING-ASSISTED DISC THAT CLOSES NEAR ZERO FLOW VELOCITY. THE LIGHTWEIGHT, SINGLE DISC DESIGN CREATES A POSITIVE SHUTOFF PRIOR TO FLOW REVERSAL WHICH HELPS TO KEEP SURGES TO A MINIMUM.
- ♦ **DURABLE, HIGH QUALITY DESIGN**  
 THE CV31'S DUCTILE IRON BODY MAINTAINS THE ANTI-CORROSIVE PROPERTIES OF CAST IRON WHILE ACHIEVING A YIELD STRENGTH COMPARABLE TO CARBON STEEL. DUCTILE IRON ALSO OFFERS HIGHER PRESSURE/TEMPERATURE RATINGS THAN CAST IRON IN THE SAME PRESSURE CLASS. THE CV31 ALSO FEATURES ANTI-CORROSIVE, STAINLESS STEEL TRIM (DISC, SPRING, SHAFT) AS STANDARD.
- ♦ **RESILIENT SOFT SEATS**  
 FIELD REPLACEABLE, RESILIENT SOFT SEATS (BUNA-N O-RING) COUPLED WITH PRECISION MACHINED SEALING SURFACES HELP TO ENSURE A BUBBLE TIGHT SEAL THAT MEETS OR EXCEEDS API 598 TEST REQUIREMENTS.

## TECHNICAL

<b>PRESSURE/TEMPERATURE RATING</b> DI - ASTM A536 - CLASS 150 <sup>(1)</sup>
WOG (Non-shock): 250 PSI @ 100 °F
<b>SEAT MATERIAL</b> TEMPERATURE RANGE
BUNA-N: -20 ~ 250 °F
<b>SPRING MATERIAL</b> MAXIMUM TEMPERATURE
Series 300 Stainless Steel: 450 °F

1. Ductile Iron valves offer higher pressure ratings than Cast Iron valves. For example, Ductile Iron valves (2" ~ 24") are rated at 250 psi wog. By comparison, Cast Iron valves (2" ~ 12") are rated at 200 psi wog and (14" ~ 24") are only rated at 150 psi wog.

## APPLICATIONS

**MARKETS:** GENERAL INDUSTRY, CHEMICAL, PETROCHEMICAL, POWER, AND FOOD & BEVERAGE

**SERVICE:** INTENDED FOR LIQUID SERVICE THAT IS STEADY, CLEAN (NO ABRASIVES OR SOLIDS) AND NON-PULSATING. FLOW RATE SHOULD NOT EXCEED 15 FT/SEC. NOT RECOMMENDED FOR STEAM OR RECIPROCATING COMPRESSOR SERVICE.

**BUNA-N PROPERTIES:** MOST WIDELY USED ELASTOMER. GOOD FOR MOST PETROLEUM OILS AND FLUIDS, SILICONE GREASES AND OILS, AND COLD WATER. EXCELLENT COMPRESSION SET, TEAR, AND ABRASION RESISTANCE. POOR WEATHER RESISTANCE AND MODERATE HEAT RESISTANCE. NOT RECOMMENDED FOR SEVERE OZONE-RESISTANT APPLICATIONS.

*The above data represents common market and service applications. No representation or guarantee, expressed or implied, is given due to the numerous variations of concentrations, temperatures and flow conditions that may occur during actual service.*

**TITAN FLOW CONTROL, INC.**  
 YOUR PIPELINE TO THE FUTURE!

Tel: 910-735-0000 ♦ Fax: 910-738-3848 ♦ titan@titanfci.com ♦ www.titanfci.com  
 290 Corporate Drive ♦ PO Box 7408 ♦ Lumberton, NC 28358



**TITAN FLOW CONTROL, Inc.**  
 290 Corporate Drive E-mail: titan@titanfci.com  
 Lumberton, NC 28358 Web: www.titanfci.com  
 Tel: 910.735.0000  
 Fax: 910.738.3848

**SWING CHECK VALVE • WAFER TYPE • SINGLE DISC**

**MODEL: CV 31-DI (Ductile Iron Body)**

**Buna-N Seat • Stainless Steel Disc**

**ANSI Class 150**

**BILL OF MATERIALS (1)**

No.	PART	CV 31-DI
1	Body	Ductile Iron ASTM A536
2	Seat (2)	Buna-N O-Ring
3	Disc (2)	Stainless Steel AISI 316
4	Plug	Carbon Steel ASTM A307B
5	Spring (2)	Series 300 Stainless Steel
6	Spacer	PTFE Commercial
7	Shaft	Stainless Steel AISI 316
8	Eye Bolt	Carbon Steel ASTM A307B

1. Bill of Materials represents standard materials. Equivalent or better materials may be substituted at the manufacturer's discretion. All materials conform to ASTM specifications.
2. Denotes recommended spare parts.

Illustrations are for representational purposes only. Request certified drawings when required.

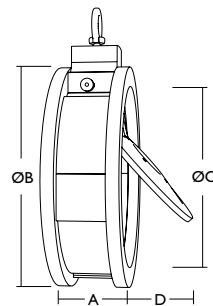
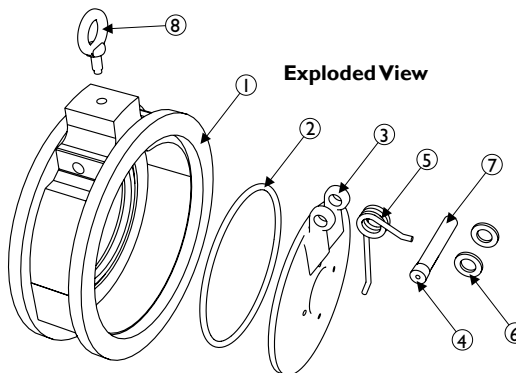

**Side View**  
(shown with disc open)

**DIMENSIONS AND PERFORMANCE DATA (1)**

SIZE	in	2	2 1/2	3	4	5	6	8	10	12
	mm	50	65	80	100	125	150	200	250	300
<b>A DIMENSION</b> FACE TO FACE (2)	in	1.75	1.875	2.00	2.25	2.50	2.75	2.875	3.125	3.375
	mm	45	48	51	58	64	70	74	80	86
<b>ØB DIMENSION</b> OVERALL DIAMETER	in	4.0	4.875	5.25	6.875	7.75	8.75	11.00	13.375	16.125
	mm	102	124	133	175	197	223	280	340	410
<b>ØC DIMENSION</b> INLET DIAMETER	in	1.313	1.85	2.063	3.00	3.75	4.75	6.438	7.625	9.50
	mm	34	47	53	77	96	121	164	194	242
<b>D DIMENSION</b> DISC MAX TRAVEL	in	.50	.75	1.31	2.31	2.75	3.38	4.00	4.75	5.00
	mm	13	20	34	59	70	86	102	121	127
<b>ASSEMBLED WEIGHT</b>	lb	4.0	5.0	7.0	11.0	16.0	16.0	32.0	44.0	60.0
	kg	1.8	2.3	3.2	5.0	7.2	7.3	14.5	20.0	27.2
<b>Flow Coefficient</b>	C <sub>v</sub>	62	109	166	318	471	720	1384	2298	4153
<b>Cracking Pressure (3)</b>	psi	≤ .25	≤ .25	≤ .25	≤ .25	≤ .25	≤ .25	≤ .25	≤ .25	≤ .25

1. Dimensions, weights, and flow coefficients are for reference only. When required, request certified drawings.
2. Face to face values have a tolerance of ±0.06 in (±2.0 mm) for sizes 10" and lower and a tolerance of ±0.12 in (±3.0 mm) for sizes 12" and larger.
3. Cracking pressure is for horizontal installations only. For vertical installations, please consult factory.

**PRESSURE-TEMPERATURE RATINGS**

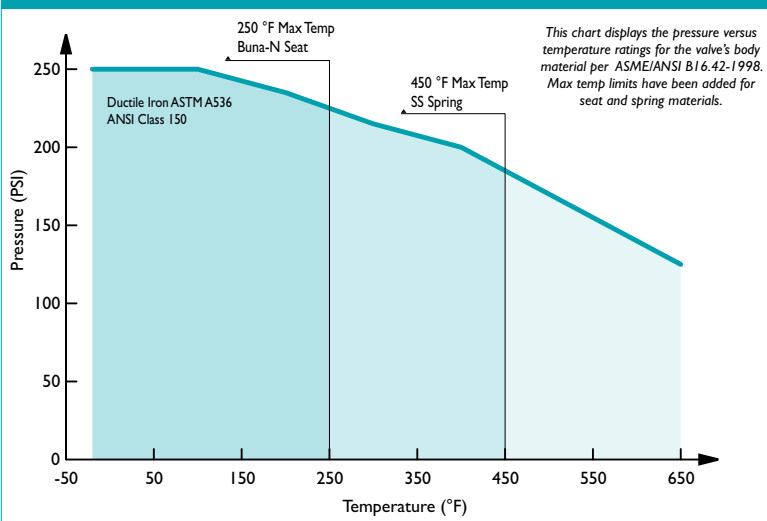

**Ductile Iron Application Notes:** Ductile Iron maintains the anti-corrosive properties of Cast Iron while achieving a yield strength comparable to Carbon Steel. Ductile Iron also offers higher pressure/temperature ratings than Cast Iron. For example, Ductile Iron check valves (class 150 - sizes 2" ~ 24") are rated at 250 psi wog. By comparison, Cast Iron check valves (class 125 - sizes 2" ~ 12") are rated at 200 psi wog and (sizes 14" ~ 24") are only rated at 150 psi wog. Ductile Iron ANSI Classes 150 has the same bolting pattern as Cast Iron ANSI Class 125.

**REFERENCED STANDARDS & CODES**

CODE	DESCRIPTION
ANSI B16.42	Ductile Iron Pipe Flanges and Flanged Fittings
ANSI B16.5	Pipe Flanges & Flanged Fittings
API 594	Wafer, Wafer-Lug, & Double Flanged Type Check Valve
API 598	Valve Inspection and Testing
MSS SP-6	Standard Finishes for Connecting-end Flanges
MSS SP-25	Standard Marking System for Valves
MSS SP-55	Quality Standard for Valve Castings

**PRESSURE/TEMPERATURE RATING (1)**

Pressure Class	Ductile Iron A536 Class 150
WOG (Non-shock)	250 PSI @ 100 °F

**SEAT AND SPRING TEMPERATURE RATINGS (1)**

SEAT (O-Ring)	Temperature Range
Buna-N	-20 °F @ 250 °F
SPRING	Maximum Temperature
Series 300 Stainless Steel	450 °F

1. The listed pressure and temperature ratings for the valve's body, seat, and spring are theoretical and may vary during actual operating conditions.

Titan FCI makes every effort to ensure the information presented on our literature accurately reflects exact product specifications. However, as product changes occur, there may be short-term differences between actual product specifications and the information contained within our literature. Titan FCI reserves the right to make design and specification changes to improve our products without prior notification. When required, request certified drawings.