

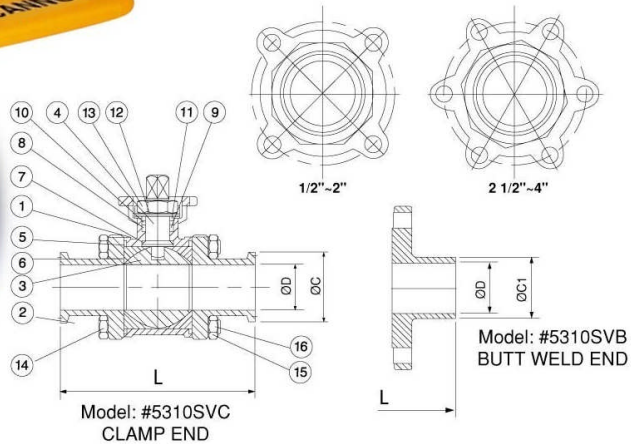

3-PC STAINLESS STEEL SANITARY BALL VALVE

ISO5211 DIRECT MOUNTING PAD
STANDARD BORE 1000WOG
1/2"~4"

Model: #5310SVB
BUTT WELD END

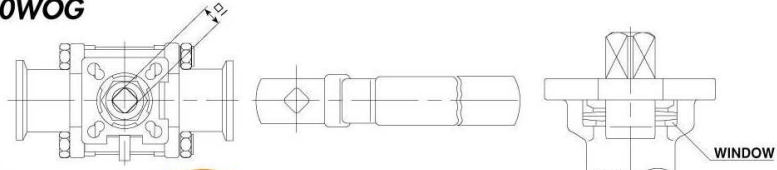

Model: #5310SVC
CLAMP END

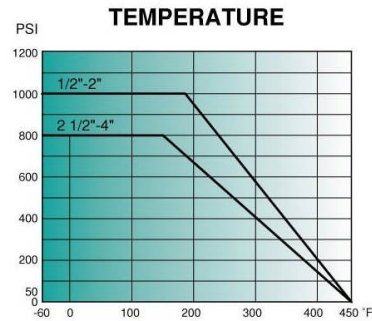

SIZE OF CLAMP & BUTT WELD END

DIMENSIONS

(inch)

SIZE	øC	øC1	øD	□I	L	TORQUE INCH/LBS	ISO5211	LBS SVC	LBS SVB
1/2"	0.98	0.50	0.37	0.35	3.50	62	F03 F04	1.59	1.34
3/4"	0.98	0.75	0.63	0.35	3.98	97	F03 F04	1.85	1.85
1"	1.98	1.00	0.87	0.43	4.49	151	F04 F05	3.09	2.56
1-1/2"	1.98	1.50	1.38	0.55	5.51	257	F05 F07	6.94	6.33
2"	2.54	2.00	1.87	0.55	6.14	398	F05 F07	9.66	8.84
2 1/2"	3.05	2.50	2.37	0.67	7.76	558	F07 F10	20.28	19.62
3"	3.58	3.00	2.87	0.67	9.02	682	F07 F10	28.66	28.00
4"	4.68	4.00	3.83	0.87	9.49	1363	F10	45.64	63.05

MATERIAL LIST

NO.	PART NAME	QTY	MATERIAL
1	Body	1	CF8M
2	End Cap	2	CF8M
3	Ball	1	SUS316
4	Stem	1	SUS316
5	Body Seat	2	PTFE
6	Seat/Cavity Filler	2	PTFE
7	Stem Seal	1	PTFE
8	O-Ring	1	VITON
9	V-Ring Packing	1Set	PTFE
10	Bushing	1	50%S.S Powder Filled PTFE
11	Gland	1	SUS 304
12	Bellville Washer	2	SUS 304
13	Stem Nut	1	SUS 304
14	Bolt	*	SUS 304
15	Washer	*	SUS 304
16	Bolt Nut	*	SUS 304