

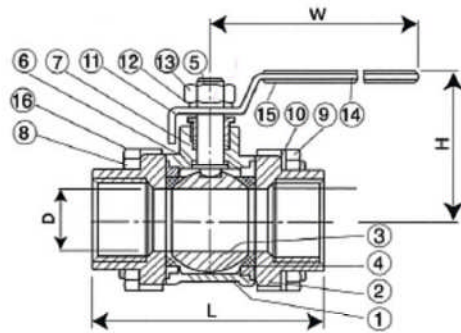

3-PC 1000 WOG STAINLESS STEEL BALL VALVE

FULL PORT, SCREWED END

MODEL: #531

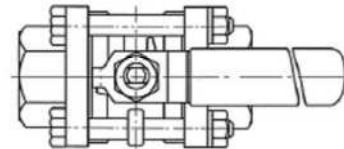

PRESSURE / TEMP. RATINGS

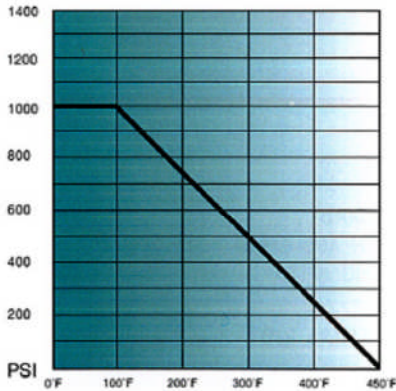

DIMENSIONS

(inch)

SIZE	D	L	H	W	CV FACTOR	LBS
1/4"	0.46	2.36	1.97	4.04	6	0.75
3/8"	0.50	2.36	1.97	4.04	7	0.71
1/2"	0.59	2.72	2.28	5.12	10	1.23
3/4"	0.82	3.07	2.44	5.12	25	1.59
1"	1.00	3.31	2.87	6.02	35	2.25
1-1/4"	1.26	4.09	3.07	6.02	46	3.31
1-1/2"	1.52	4.69	3.27	7.17	80	5.25
2"	1.97	5.16	3.58	7.17	110	7.80
2-1/2"	2.56	6.38	5.28	9.06	310	15.70
3"	3.15	7.17	5.83	9.06	360	22.84
4"	3.94	9.06	6.85	11.02	820	42.11

STANDARD

DESIGN: ANSI B16.34

TESTING: API 598

MATERIAL LIST

NO.	PART NAME	SPECIFICATION
1	BODY	ASTM-CF8M-A351
2	BODY CAP	ASTM-CF8M-A351
3	BALL	ASTM-CF8M-A351
4	SEAT	PTFE
5	STEM	AISI 316
6	THRUST WASHER	PTFE
7	STEM PACKING	PTFE
8	BOLT	AISI 304
9	HEX NUT	AISI 304
10	BOLT WASHER	AISI 304
11	GLAND NUT	AISI 304
12	STEM WASHER	AISI 304
13	STEM NUT	AISI 304
14	HANDLE	AISI 304
15	COVER	PLASTIC
16	JOINT GASKET	PTFE